



Operation Manual

PRODUCT NAME

Micro Mist Separator Regulator

MODEL / Series / Product Number

AWD20-(F,N)01~(F,N)02(B,C,E,E1,E2,E3,E4,G,H,M)(-1,2,6,C,J,N,R,Z,ZA)-D

AWD30-(F,N)02~(F,N)03(B,C,D,E,E1,E2,E3,E4,G,H,M)(-1,2,6,8,J,N,R,W,Z,ZA)-D

AWD40-(F,N)02~(F,N)04(B,C,D,E,E1,E2,E3,E4,G,H,M)(-1,2,6,8,J,N,R,W,Z,ZA)-D

SMC Corporation

Contents

	Page
1. Safety Instructions	2-8
2. Application	9
3. Standard Specifications	9
4. How to Order	10
5. Options	11
6. Structural Drawing and Replacement Parts	12-13
7. Bowl Assembly Specifications	14-21
8. Assembly of Optional Parts	22
9. Operation and Adjustment	23-25
10. Trouble Shooting	26-27
11. How to Replace the Components	28-37
11-1. Diaphragm Assembly Replacement	28
11-2. Bowl Assembly Replacement	29-30
11-3. Element Replacement	31-32
11-4. Valve Assembly Replacement	33-34
11-5. Square Embedded Type Pressure Gauge Replacement	35
11-6. Blanking Plate Assembly Replacement	36
11-7. Plug Assembly Replacement	37
12. Disassembly Drawing	38-39
13. Dimensions	40-41



Safety Instructions

These safety instructions are intended to prevent hazardous situations and/or equipment damage. These instructions indicate the level of potential hazard with the labels of “Caution,” “Warning” or “Danger.” They are all important notes for safety and must be followed in addition to International Standards (ISO/IEC)*1), and other safety regulations.

*1) ISO 4414: Pneumatic fluid power -- General rules relating to systems.

ISO 4413: Hydraulic fluid power -- General rules relating to systems.

IEC 60204-1: Safety of machinery -- Electrical equipment of machines .(Part 1: General requirements)

ISO 10218: Manipulating industrial robots -Safety.

etc.



Caution

Caution indicates a hazard with a low level of risk which, if not avoided, could result in minor or moderate injury.



Warning

Warning indicates a hazard with a medium level of risk which, if not avoided, could result in death or serious injury.



Danger

Danger indicates a hazard with a high level of risk which, if not avoided, will result in death or serious injury.

Warning

1. The compatibility of the product is the responsibility of the person who designs the equipment or decides its specifications.

Since the product specified here is used under various operating conditions, its compatibility with specific equipment must be decided by the person who designs the equipment or decides its specifications based on necessary analysis and test results.

The expected performance and safety assurance of the equipment will be the responsibility of the person who has determined its compatibility with the product.

This person should also continuously review all specifications of the product referring to its latest catalog information, with a view to giving due consideration to any possibility of equipment failure when configuring the equipment.

2. Only personnel with appropriate training should operate machinery and equipment.

The product specified here may become unsafe if handled incorrectly.

The assembly, operation and maintenance of machines or equipment including our products must be performed by an operator who is appropriately trained and experienced.

3. Do not service or attempt to remove product and machinery/equipment until safety is confirmed.

1. The inspection and maintenance of machinery/equipment should only be performed after measures to prevent falling or runaway of the driven objects have been confirmed.

2. When the product is to be removed, confirm that the safety measures as mentioned above are implemented and the power from any appropriate source is cut, and read and understand the specific product precautions of all relevant products carefully.

3. Before machinery/equipment is restarted, take measures to prevent unexpected operation and malfunction.

4. Contact SMC beforehand and take special consideration of safety measures if the product is to be used in any of the following conditions.

1. Conditions and environments outside of the given specifications, or use outdoors or in a place exposed to direct sunlight.

2. Installation on equipment in conjunction with atomic energy, railways, air navigation, space, shipping, vehicles, military, medical treatment, combustion and recreation, or equipment in contact with food and beverages, emergency stop circuits, clutch and brake circuits in press applications, safety equipment or other applications unsuitable for the standard specifications described in the product catalog.

3. An application which could have negative effects on people, property, or animals requiring special safety analysis.

4. Use in an interlock circuit, which requires the provision of double interlock for possible failure by using a mechanical protective function, and periodical checks to confirm proper operation.



Safety Instructions

Caution

The product is provided for use in manufacturing industries.

The product herein described is basically provided for peaceful use in manufacturing industries.

If considering using the product in other industries, consult SMC beforehand and exchange specifications or a contract if necessary.

If anything is unclear, contact your nearest sales branch.

Limited warranty and Disclaimer/Compliance Requirements

The product used is subject to the following “Limited warranty and Disclaimer” and “Compliance Requirements”.

Read and accept them before using the product.

Limited warranty and Disclaimer

1. The warranty period of the product is 1 year in service or 1.5 years after the product is delivered, whichever is first.*2)

Also, the product may have specified durability, running distance or replacement parts. Please consult your nearest sales branch.

2. For any failure or damage reported within the warranty period which is clearly our responsibility, a replacement product or necessary parts will be provided.

This limited warranty applies only to our product independently, and not to any other damage incurred due to the failure of the product.

3. Prior to using SMC products, please read and understand the warranty terms and disclaimers noted in the specified catalog for the particular products.

*2) Vacuum pads are excluded from this 1 year warranty.

A vacuum pad is a consumable part, so it is warranted for a year after it is delivered.

Also, even within the warranty period, the wear of a product due to the use of the vacuum pad or failure due to the deterioration of rubber material are not covered by the limited warranty.

Compliance Requirements

1. The use of SMC products with production equipment for the manufacture of weapons of mass destruction(WMD) or any other weapon is strictly prohibited.

2. The exports of SMC products or technology from one country to another are governed by the relevant security laws and regulation of the countries involved in the transaction. Prior to the shipment of a SMC product to another country, assure that all local rules governing that export are known and followed.

Caution

SMC products are not intended for use as instruments for legal metrology.

Measurement instruments that SMC manufactures or sells have not been qualified by type approval tests relevant to the metrology (measurement) laws of each country.

Therefore, SMC products cannot be used for business or certification ordained by the metrology (measurement) laws of each country.

Precautions for Design

Warning

- (1) Consult SMC if no leakage is allowed due to the environment, or if the operating fluid is not air.
- (2) Polycarbonate resin is used for the external parts including the bowl. Organic solvents including thinner, acetone, alcohol and ethylene chloride; chemicals including sulphuric acid, nitric acid and hydrochloric acid; cutting oil, synthetic oils, ester-based compressor oil, alkali, kerosene, gasoline, lock material of screw are harmful. Do not use the product where these are present.

Chemical resistance of polycarbonate and nylon bowl

Type	Chemical name	Application examples	Material	
			Polycarbonate	Nylon
Acid	Hydrochloric acid Sulfuric acid Phosphoric acid Chromic acid	Acid washing liquid for metals	△	×
Alkaline	Sodium hydroxide (Caustic soda) Potash Calcium hydroxide (Slack lime) Ammonia water Carbotane of soda	Degreasing of metals Industrial salts Water-soluble cutting oil	×	○
Inorganic salts	Sodium sulfide Potassium nitrate Sulfate of soda	-	×	△
Chlorine solvents	Carbon tetrachloride Chloroform Ethylene chloride Methylene chloride	Cleaning liquid for metals Printing ink Dilution	×	△
Aromatic series	Benzene Toluene Paint thinner	Coatings Dry cleaning	×	△
Ketone	Acetone Methyl ethyl ketone Cyclohexane	Photographic film Dry cleaning Textile industries	×	×
Alcohol	Ethyl alcohol IPA Methyl alcohol	Antifreeze Adhesives	△	×
Oil	Gasoline Kerosene	-	×	○
Ester	Phthalic acid dimethyl Phthalic acid diethyl Acetic acid	Synthetic oil Anti-rust additives	×	○
Ether	Methyl ether Ethyl ether	Brake oil additives	×	○
Amino	Methyl amino	Cutting oil Brake oil additives Rubber accelerator	×	×
Others	Thread-lock fluid Sea water Leak tester	-	×	△

○: Essentially safe. △: Some effects may occur. ×: Effects will occur.

When the above factors are present or there is some doubt, use a metal bowl for safety.

- (3) Avoid the application where charge and discharge of pressure to/from a standard bowl is switched frequently. This may damage the bowl. A metal bowl is recommended in these cases.
- (4) Shield from ultra violet light and radiation with protective cover.
- (5) A safety device needs to be installed if output pressure is exceeding the set pressure, otherwise this can cause breakage of outlet device and equipment or lead to malfunction.

 **Caution**

- (1) AD27-D with auto drain may have leakage of accumulated drain during pressure exhaust (this leakage is allowed in their constructions and not considered failure). Be sure to connect piping for drain.
- (2) Allowed air consumption from the exhaust port is 0.1 L/min(ANR) or less.
- (3) Please install the product in a location where pulsation is unlikely to occur. When the difference between the inside and outside exceeds 0.1MPa, the element might be broken

Selection

 **Warning**

- (1) Grease used on the internal sliding parts and seals may flow to the outlet side. If this is not acceptable, please consult SMC.
- (2) N.O. type auto drain should be operated under the following conditions to avoid malfunction.
Operating compressor: 0.75 kW or more, Discharged flow rate: 100 L/min (ANR) or more
When using 2 or more auto drains, multiply the value above by the number of auto drains to find the capacity of the compressors you will need. For example, when using 2 auto drains, 1.5 kW (200 L/min (ANR)) of the compressor capacity is required. The operating pressure should be 0.1 MPa or more.
- (3) N.C. type auto drain should be operated under the following conditions to avoid malfunction.
Operating pressure for AD27: 0.1 MPa or more, for AD37 and AD47: 0.15 MPa or more.
- (4) Removing of residual pressure (removing of outlet pressure) will not be achieved by releasing inlet pressure. To remove residual pressure, please use the combination of a filter regulator with backflow function, mist separator and micro mist separator.
- (5) Long absence of operation or operation with sealed circuit or balancing circuit on the outlet side may cause set pressure fluctuation. Please consult SMC if this is not acceptable.
- (6) Set range of outlet pressure shall be 85% or less of the inlet pressure. Operating at a setting exceeding 85% causes the outlet pressure to be easily affected by fluctuations in flow rate and inlet pressure, leading to instability.
- (7) Since the safety margin is calculated to the maximum value of the set pressure range shown in the specification table, the pressure setting may be over the maximum value. However, use the product within the specified range.
- (8) If the product is used with circuit which requires high exhaust sensitivity or set precision, please consult SMC.
- (9) Do not flow air exceeding the maximum air flow rate. If the maximum air flow rate is momentarily exceeded, it may cause splashing of drainage and oil on the outlet side, and damage to the equipment.

Installation

Warning

- (1) Do not drop or apply impact during transportation or installation. It will cause damage to the product and result in operation failure.
- (2) Do not install in areas of high humidity or high temperature. Operation outside of the product specification range may cause damage to the product or operation failure, or shorten the product life.
- (3) Connect the product ensuring the direction of "1"(IN) and "2"(OUT) for air direction and indicated arrow. Incorrect connections may cause malfunction.
- (4) Install with adequate space for maintenance beneath the product. Refer to section [13. Dimensions] (p. 40 and p. 41) for necessary space.
- (5) Install vertically so that outlet of drain is downward. It cannot be used in horizontal or upward direction as it may cause operation failure.

Adjustment

Warning

- (1) Adjust the set pressure ensuring correct inlet and outlet pressures. Turning the knob excessively can cause damage to the internal parts.
- (2) Do not use tools on the pressure regulator knob as this may cause damage. It must be operated manually.

Caution

- (1) For the product with a pressure gauge, do not apply pressure exceeding the maximum scale of the pressure gauge in order to protect the gauge.
- (2) Adjust the pressure whilst the pressure is increasing. Pressure may become lower than the set pressure if adjusted by decreasing the value. Rotate the knob clockwise to increase the set pressure. Counterclockwise to decrease the pressure. Moreover, please lock the knob after setting pressure.
- (3) Outlet pressure may rise when the inlet pressure is discharged and resupplied after pressure setting. In this case, consume air at the outlet which will bring the pressure closer to the set pressure.
- (4) Outlet pressure may change if the product is used for a long period of time. Please confirm the set pressure regularly.
- (5) When pressure difference between the inlet side and the outlet side is large, chattering may occur. In that case, please reduce the pressure difference between the inlet and the outlet. Please consult SMC if chattering continues.

Piping

Warning

- (1) Before piping is connected, it should be thoroughly blown out with air (flushing) or washed to remove chips, cutting oil and solid foreign material from inside the pipe. Contamination of piping may cause damage or malfunction.
- (2) When screwing together pipes and fittings, etc., be certain that chips from the pipe threads and sealant do not get inside the pipe. When a sealant tape is used, leave 1.5 to 2 thread ridges exposed at the end of the threads.
- (3) Connect piping/fittings using the recommended torque while holding the female thread side tightly. Insufficient tightening torque leads to cause of loosening or sealing failure, and excessive tightening torque leads to cause of breakage of screws. Tightening without holding female thread applies an excessive force to the piping bracket directly, leading to breakage.

Recommended tightening torque
of tube connection port

Unit: N m

Thread size	1/8	1/4	3/8	1/2
Torque	7 to 9	12 to 14	22 to 24	28 to 30

Recommended tightening torque of
pressure gauge connection port

Unit: N m

Thread size	1/8
Torque	3 to 5

- (4) Before using an SMC fitting and S coupler, please refer to "Tightening the threaded portion of the connection thread" of the Fittings & Tubing Precautions.
- (5) Do not apply torsion or bending moment other than the weight of the product itself. External piping needs to be supported separately as it may cause breakage. Non-flexible piping like steel tube is susceptible to excessive moment load or vibration. Insert flexible tubes to prevent this.
- (6) Drain guide is not equipped with valve function. Be sure to connect piping for drain. No piping for drain allows the drain and compressed air to exhaust freely. Also, the piping installation should be performed with drain guide held by spanner to prevent breakage of bowl.
- (7) The piping for drain from auto drain should be connected under the following requirements to avoid operating failure.
Tubing for AD27-D: I.D. $\phi 2.5$ ($\phi 3/32$ ") or larger, Length 5 m (200 inch) or shorter
Tubing for AD37, 47(N)-D: I.D. $\phi 4$ ($\phi 3/16$ ") or larger, Length 5 m (200 inch) or shorter
Tubing for AD38, 48(N)-D: I.D. $\phi 6.5$ ($\phi 1/4$ ") or larger, Length 5 m (200 inch) or shorter

Air Source

Warning

- (1) Use clean air. Do not use compressed air containing chemicals, organic solvent, synthetic oil or corrosive gas as it may be cause of breakage of components or operation failure.
- (2) Air containing too much moisture may cause malfunction. Install an air drier or aftercooler before the product.

Caution

- (1) When the element becomes clogged at an early stage, please check the air quality. In addition, early clogging can be prevented by attaching a pre-filter on the inlet side of the product.

Maintenance

Warning

- (1) Release the pressure in the product to the atmosphere when replacing parts or removing piping.
- (2) Maintenance and checks should be done by following the procedure in this operation manual. Incorrect handling of the product may cause breakage or operation failure of the equipment or device.
- (3) Perform periodical check to find cracks, flaws or other deterioration on resin bowl. If any of these appear, replace with a new or metal bowl. Otherwise, breakage may occur. Investigate and/or review the operating conditions if necessary.
- (4) Check for dirt in resin bowl periodically. If any dirt is seen, replace with new bowl. If removing dirt by washing the resin bowl, never use washing material other than neutral detergent. Otherwise, the bowl is damaged.
- (5) Open and close the drain cock manually. The use of tools can result in damage to the product.
- (6) Replace the element every 2 years or when the pressure drop at the output pressure from initial operation becomes 0.1 MPa, whichever comes first, to prevent damage to the element.
- (7) Discharge the drain inside the case before it reaches the element assembly. Refer to 9. Operation and Adjustment (p. 24 and p. 25) for the drain discharging method.

Caution

- (1) If an emergency countermeasure is to be taken during setting failure or exhaust leakage, the internal valve seating part should be checked. If failure such as foreign matter is found, remove it before performing the emergency countermeasure.
- (2) Check the element periodically and replace it with a new one if necessary. If it is found that outlet pressure drops lower than the normal condition or the flow is restricted during operation, check the condition of the element.
- (3) For the N.C. type auto drain, when there is no pressure, drain which does not operate the auto drain mechanism will remain in the bowl. It is recommended to release the residual drain manually at the end of the working day.

2. Application

This product is used for removing oil content and solid foreign matter in the air line as well as for pressure control.

3. Standard Specifications

Model		AWD20-D	AWD30-D	AWD40-D
Port size		1/8, 1/4	1/4, 3/8	1/4, 3/8, 1/4
Pressure gauge port size ^{Note 1)}		1/8		
Fluid		Air		
Ambient and fluid temperature ^{Note 2)}		-5 to 60 °C (with no freezing)		
Proof pressure		1.5MPa		
Max. operating pressure		1.0MPa		
Set pressure range	Without auto drain	0.05 to 0.85MPa		
	Auto drain (N.C)	0.1 to 0.85MPa	0.15 to 0.85MPa	
	Auto drain (N.O)	—	0.1 to 0.85MPa	
Max. air flow capacity ^{Note 3)}		90L/min(ANR)	180L/min(ANR)	450L/min(ANR)
Filtration rating		0.01 µm (99.9% filtered particle size)		
Outlet side oil mist concentration		Max. 0.1 mg/m ³ (ANR) (Before saturated with oil 0.01 mg/m ³ (ANR) or less ≈ 0.008 ppm)		
Compressed air quality class ^{Note 4)}		ISO8573-1:2010[1:4:2]		
Drain capacity		8cm ³	25cm ³	45cm ³
Bowl material		Polycarbonate		
Bowl guard		Semi-standard (Steel)	Standard (Polycarbonate)	
Construction		Relieving type		
Weight		0.23kg	0.35kg	0.66kg

Note 1) Pressure gauge connection threads are not available for product with a square embedded type pressure gauge or with a digital pressure switch.

Note 2) -5 to 50°C for the products with the digital pressure switch.

Note 3) Inlet pressure is 0.7 MPa and outlet pressure is 0.5 MPa. Flow at 20°C, atmospheric pressure, and 65% of relative humidity.

The maximum air flow capacity varies depending on the inlet pressure.

Keep the air flow below the maximum air flow capacity to prevent an outflow of lubricant to the outlet side.

Note 4) Based on ISO8573-1:2010 Compressed air - Part 1: Contaminants and purity classes.

The compressed air quality class on the inlet side is [7:4:4].

4. How to Order

AWD **30** - **□** **03** **BE** - **□** - D

1
2
3
4
5

		Symbol	Description	①			
				Body size			
				20	30	40	
②	Thread type	Nil	Rc	●	●	●	
		N	NPT	●	●	●	
		F	G	●	●	●	
③	Port size	01	1/8	●	—	—	
		02	1/4	●	●	●	
		03	3/8	—	●	●	
		04	1/2	—	—	●	
④	a	Mounting	Nil	Without mounting option	●	●	●
			B	With bracket	●	●	●
			H	With set nut (for panel mount)	●	●	●
	b	Float type auto drain	Nil	Without auto drain	●	●	●
			C	N.C. (Normally closed) Drain port is closed when pressure is not supplied.	●	●	●
			D	N.O. (Normally opened) Drain port is opened when pressure is not supplied.	—	●	●
	c	Pressure gauge	Nil	Without pressure gauge	●	●	●
			E	Square embedded type pressure gauge (with limit indicator)	●	●	●
			G	Round type pressure gauge (with limit indicator)	●	●	●
			M	Round type pressure gauge (with color zone)	●	●	●
		Digital pressure switch	E1	NPN output / Wiring bottom entry	●	●	●
			E2	NPN output/ Wiring top entry	●	●	●
			E3	PNP output / Wiring bottom entry	●	●	●
E4	PNP output/ Wiring top entry		●	●	●		
⑤	d	Set pressure	Nil	0.05 to 0.85 MPa setting	●	●	●
			1	0.05 to 0.2 MPa setting	●	●	●
	e	Bowl	Nil	Polycarbonate bowl	●	●	●
			2	Metal bowl	●	●	●
			6	Nylon bowl	●	●	●
			8	Metal bowl with level gauge	—	●	●
			C	With bowl guard	●	—	—
			6C	With bowl guard (Nylon bowl)	●	—	—
	f	Drain port	Nil	With drain cock	●	●	●
			J	Drain guide 1/8	●	—	—
				Drain guide 1/4	—	●	●
			W	Drain cock with barb fitting	—	●	●
	g	Exhaust mechanism	Nil	Relieving type	●	●	●
			N	Non-relieving type	●	●	●
	h	Flow direction	Nil	Flow direction: Left to right	●	●	●
			R	Flow direction: Right to left	●	●	●
	i	Pressure unit Temp. unit	Nil	Pressure unit: MPa Temp. unit: °C	●	●	●
			Z	Pressure unit: psi Temp. unit: °F	○ (Note 2)	○ (Note 2)	○ (Note 2)
			ZA	Digital pressure switch: With unit selection function	△ (Note 3)	△ (Note 3)	△ (Note 3)

Note 1) ④Option and ⑤Semi-standard: Select one each for a to i.

Note 2) ○: For NPT thread type only.

Note 3) △: Select with an option E1, E2, E3 or E4.

5. Options

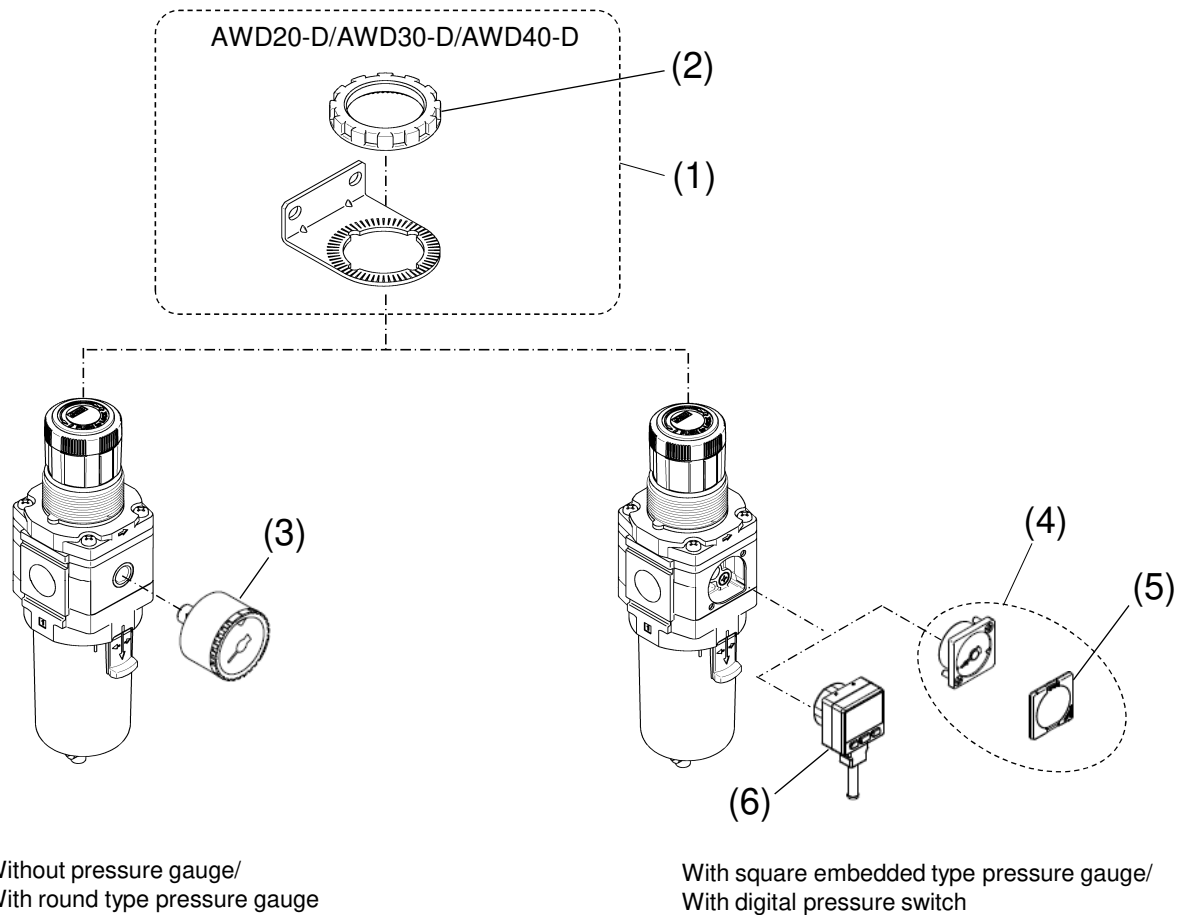

Options

No.	Part name	Piping thread type	Semi-standard specification	Part No.				
				AWD20-D	AWD30-D	AWD40-D		
(1)	Bracket assembly ^{Note 1)}	-	-	AW23P-270AS	AR33P-270AS	AR43P-270AS		
(2)	Set nut	-	-	AR23P-260S	AR33P-260S	AR43P-260S		
(3)	Pressure gauge ^{Note 2)} (Round type)	Rc	-	G36-10-01		G46-10-01		
		NPT	-	G36-10-N01		G46-10-N01		
			Z : Both in MPa and psi	G36-P10-N01-X30		G46-P10-N01-X30		
	Pressure gauge ^{Note 2)} (Round type with color zone)	G	-	G36-10-01		G46-10-01		
		Rc	-	G36-10-01-L		G46-10-01-L		
		NPT	-	G36-10-N01-L		G46-10-N01-L		
(4)	Square embedded type pressure gauge ^{Note 3)} (Including part (5))	-	-	GC3-10AS-D				
		NPT	Z : Both in MPa and psi	GC3-P10AS-D-X30				
(5)	Pressure gauge cover assembly	-	-	136150A				
(6)	Digital pressure switch (with accessories for mounting)	-	-	<Common for all sizes>				
					Output	Wiring bottom entry	Wiring top entry	
					NPN	ISE35-N-25-MLA-X523	ISE35-R-25-MLA-X523	
					PNP	ISE35-N-65-MLA-X523	ISE35-R-65-MLA-X523	
				-	ZA : Unit selection function	NPN	ISE35-N-25-LA-X523	ISE35-R-25-LA-X523
						PNP	ISE35-N-65-LA-X523	ISE35-R-65-LA-X523
NPT	Z : Unit selection function Initial setting: psi	NPN	ISE35-N-25-PLA-X523	ISE35-R-25-PLA-X523				
		PNP	ISE35-N-65-PLA-X523	ISE35-R-65-PLA-X523				

Note) The numbers in the table and structural drawings are consistent with the numbers in sections [11. How to Replace the Components] (P28-37) and [12. Disassembly Drawing] (P38-39).

Note 1) This is an assembly of a bracket and set nut (2).

Note 2) Part number for 0.2 MPa: G36-4-01 (Rc type) / G36-4-N01 (NPT type) / G36-P4-N01-X30 (NPT, Z type) .

G46-4-01 (Rc type) / G46-4-N01 (NPT type) / G46-P4-N01-X30 (NPT, Z type).

Note 3) With O-ring (1 pc.) and mounting screws (2 pcs.). Part number for 0.2 MPa: GC3-4AS-D (Rc, NPT type) / GC3-P4AS-D-X30 (NPT, Z type).

6. Structural Drawing and Replacement Parts

Structural drawing / Common replacement parts

AWD20-D

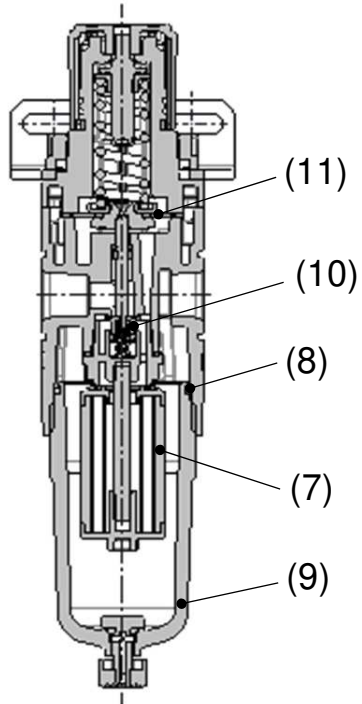

AWD30-D/AWD40-D

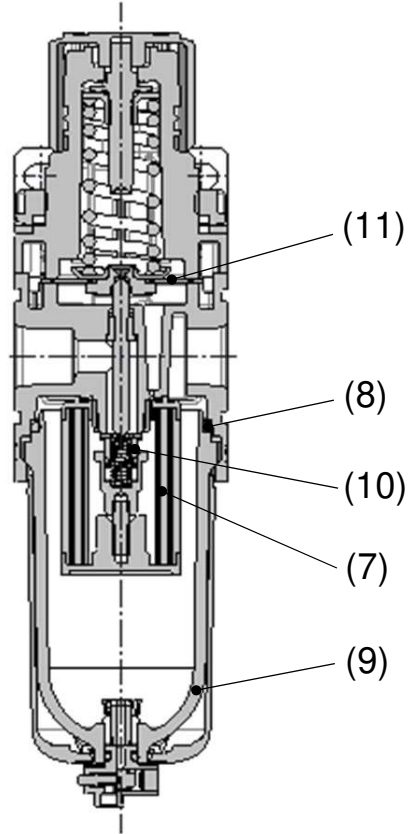

Without pressure gauge /
With round type pressure gauge

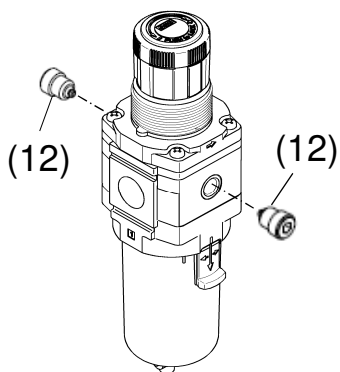

With square embedded type pressure gauge /
With digital pressure switch

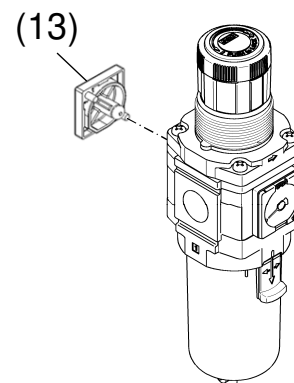

Replacement parts

No.	Part name	Piping thread type	Semi-standard specification	Part No.		
				AWD20-D	AWD30-D	AWD40-D
(7)	Element assembly	—	—	AFD20P-060AS	AFD30P-060AS	AFD40P-060AS
(8)	Bowl seal	—	—	C2SFP-260S	C32FP-260S	C42FP-260S
(9)	Bowl assembly	Refer to section [7. Bowl Assembly Specifications] (P14-P21).				
	Auto drain (N.C.)					
	Auto drain (N.O.)					
(10)	Valve assembly	—	—	AWM24P-090AS	AWM34P-090AS	AWM44P-090AS
(11)	Diaphragm assembly	—	- : Relief	AR24P-150AS	AR34P-150AS	AR44P-150AS
			N : Non-relief	AR24P-150AS-N	AR34P-150AS-N	AR44P-150AS-N
(12)	Plug assembly	Rc / G	—	AR24P-370AS-01		
		NPT	—	AR24P-370AS-N01		
(13)	Blanking plate assembly	—	—	AR24P-250AS		

Note) The numbers in the table and structural drawings are consistent with the numbers in sections [11. How to Replace the Components] (P28-37) and [12. Disassembly Drawing] (P38-39).

7. Bowl Assembly Specifications

1. Bowl assembly / auto drain for AWD20-D

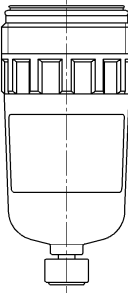
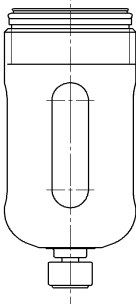
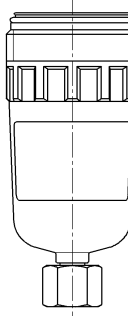
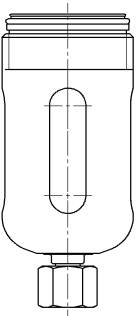
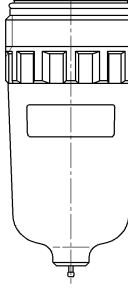
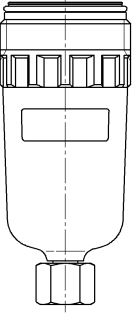
Option symbol	—		—	
Semi-standard symbol	—	6	C	6C
Appearance and part No.	Semi-standard: - (Standard)		Semi-standard: C	
	Piping port thread type	(9) Part No.	Piping port thread type	(9) Part No.
	Rc	C2SF-D	Rc	C2SF-C-D
	G	C2SF(-Z)-D	G	C2SF-C(-Z)-D
Semi-standard: 6		Semi-standard: 6C		
Piping port thread type	(9) Part No.	Piping port thread type	(9) Part No.	
Rc	C2SF-6-A	Rc	C2SF-6C-A	
G	C2SF-6(Z)-A	G	C2SF-6C(Z)-A	
NPT	C2SF-6(Z)-A	NPT	C2SF-6C(Z)-A	
				
Option symbol	—		—	
Semi-standard symbol	J	6J	CJ	6CJ
Appearance and part No.	Semi-standard: J		Semi-standard: CJ	
	Piping port thread type	(9) Part No.	Piping port thread type	(9) Part No.
	Rc	C2SF-J-D	Rc	C2SF-CJ-D
	G	C2SFF-J-D	G	C2SFF-CJ-D
Semi-standard: 6J		Semi-standard: 6CJ		
Piping port thread type	(9) Part No.	Piping port thread type	(9) Part No.	
Rc	C2SF-6J-A	Rc	C2SF-6CJ-A	
G	C2SFF-6J-A	G	C2SFF-6CJ-A	
NPT	C2SFN-6J(Z)-A	NPT	C2SFN-6CJ(Z)-A	
				
Option symbol	—		—	
Semi-standard symbol	2		2J	
Appearance and part No.	Semi-standard: 2		Semi-standard: 2J	
	Piping port thread type	(9) Part No.	Piping port thread type	(9) Part No.
	Rc	C2SF-2-A	Rc	C2SF-2J-A
	G	C2SF-2(Z)-A	G	C2SFF-2J-A
Semi-standard: 2		Semi-standard: 2J		
Piping port thread type	(9) Part No.	Piping port thread type	(9) Part No.	
Rc	C2SF-2-A	Rc	C2SF-2J-A	
G	C2SFF-2J-A	G	C2SFF-2J-A	
NPT	C2SFN-2J(Z)-A	NPT	C2SFN-2J(Z)-A	
				

Option symbol	C ^{Note 1)}		C ^{Note 1)}	
Semi-standard symbol	—	6	C	6C
Appearance and part No.	Semi-standard: —		Semi-standard: C	
	Piping port thread type	(9) Part No.	Piping port thread type	(9) Part No.
	Rc	AD27-D	Rc	AD27-C-D
	G		G	
NPT	AD27(-Z)-D	NPT	AD27-C(Z)-D	
Semi-standard: 6		Semi-standard: 6C		
Piping port thread type	(9) Part No.	Piping port thread type	(9) Part No.	
Rc	AD27-6-A	Rc	AD27-6C-A	
G		G		
NPT	AD27-6(Z)-A	NPT	AD27-6C(Z)-A	
Option symbol	C ^{Note 1)}			
Semi-standard symbol	2			
Appearance and part No.	Semi-standard: 2			
	Piping port thread type	(9) Part No.		
	Rc	AD27-2-A		
	G			
NPT	AD27-2(Z)-A			

Note 1) Minimum operating pressure is 0.1 MPa.

Note 2) Part No. (9) includes Bowl seal (8). Refer to section [12. Disassembly Drawing] (P38).

Note 3) "Z" in Part No. (9) indicates semi-standard specifications. The pressure unit: psi. The temperature unit: °F.

Note 4) Refer to section [4. How to Order] (P10) for option and semi-standard symbols.

2. Bowl assembly / auto drain for AWD30-D

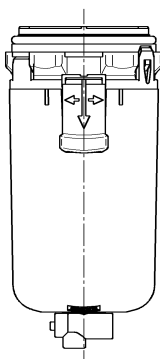
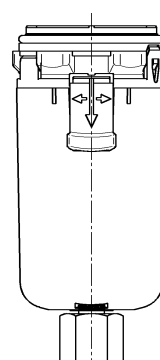
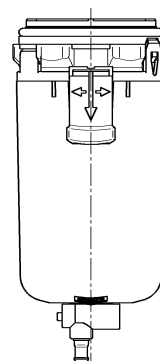
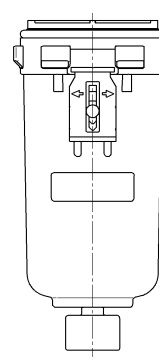
Option symbol	—		—		
Semi-standard symbol	—	6	J	6J	
Appearance and part No.	Semi-standard: — (Standard)			Semi-standard: J	
	Piping port thread type	(9) Part No.		Piping port thread type	(9) Part No.
	Rc	C3SF-D		Rc	C3SF-J-D
	G	C3SF(-Z)-D		G	C3SFF-J-D
Semi-standard: 6		Semi-standard: 6J			
Piping port thread type	(9) Part No.	Piping port thread type	(9) Part No.		
Rc	C3SF-6-A	Rc	C3SF-6J-A		
G	C3SF-6(Z)-A	G	C3SFF-6J-A		
NPT	C3SF-6(Z)-A	NPT	C3SFN-6J(Z)-A	NPT	C3SFN-6J(Z)-A
Option symbol	—		—		
Semi-standard symbol	W	6W			
Appearance and part No.	Semi-standard: W				
	Piping port thread type	(9) Part No.			
	Rc	C3SF-W-D			
	G	C3SF-W(Z)-D			
Semi-standard: 6W		Semi-standard: 6W			
Piping port thread type	(9) Part No.	Semi-standard: 6W			
Rc	C3SF-6W-A	Semi-standard: 6W			
G	C3SF-6W(Z)-A	Semi-standard: 6W			
NPT	C3SF-6W(Z)-A	Semi-standard: 6W			
Option symbol	—		—		
Semi-standard symbol	2		2J		
Appearance and part No.	Semi-standard: 2			Semi-standard: 2J	
	Piping port thread type	(9) Part No.		Piping port thread type	(9) Part No.
	Rc	C3SF-2-A		Rc	C3SF-2J-A
	G	C3SF-2(Z)-A		G	C3SFF-2J-A
NPT	C3SF-2(Z)-A	NPT	C3SFN-2J(Z)-A	NPT	C3SFN-2J(Z)-A

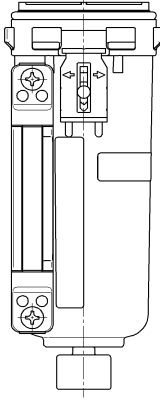
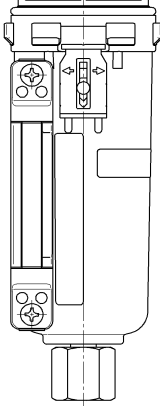
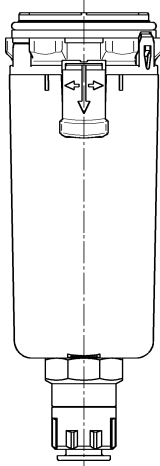
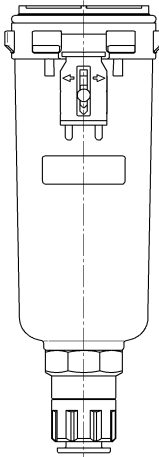
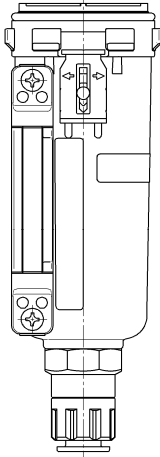
Option symbol	—		—																	
Semi-standard symbol	8		8J																	
Appearance and part No.	Semi-standard: 8 <table border="1"> <tr> <td>Piping port thread type</td> <td>(9) Part No.</td> </tr> <tr> <td>Rc</td> <td>C3LF-8-A</td> </tr> <tr> <td>G</td> <td>C3LF-8(Z)-A</td> </tr> <tr> <td>NPT</td> <td>C3LF-8(Z)-A</td> </tr> </table> 		Piping port thread type	(9) Part No.	Rc	C3LF-8-A	G	C3LF-8(Z)-A	NPT	C3LF-8(Z)-A	Semi-standard: 8J <table border="1"> <tr> <td>Piping port thread type</td> <td>(9) Part No.</td> </tr> <tr> <td>Rc</td> <td>C3LF-8J-A</td> </tr> <tr> <td>G</td> <td>C3LFF-8J-A</td> </tr> <tr> <td>NPT</td> <td>C3LFN-8J(Z)-A</td> </tr> </table> 		Piping port thread type	(9) Part No.	Rc	C3LF-8J-A	G	C3LFF-8J-A	NPT	C3LFN-8J(Z)-A
	Piping port thread type	(9) Part No.																		
Rc	C3LF-8-A																			
G	C3LF-8(Z)-A																			
NPT	C3LF-8(Z)-A																			
Piping port thread type	(9) Part No.																			
Rc	C3LF-8J-A																			
G	C3LFF-8J-A																			
NPT	C3LFN-8J(Z)-A																			
Option symbol	C ^{Note 1)}		C ^{Note 1)}																	
Semi-standard symbol	—	6	2																	
Appearance and part No.	Semi-standard: — <table border="1"> <tr> <td>Piping port thread type</td> <td>(9) Part No.</td> </tr> <tr> <td>Rc</td> <td>AD37-D</td> </tr> <tr> <td>G</td> <td>AD37N(Z)-D</td> </tr> <tr> <td>NPT</td> <td>AD37N(Z)-D</td> </tr> </table> 		Piping port thread type	(9) Part No.	Rc	AD37-D	G	AD37N(Z)-D	NPT	AD37N(Z)-D	Semi-standard: 2 <table border="1"> <tr> <td>Piping port thread type</td> <td>(9) Part No.</td> </tr> <tr> <td>Rc</td> <td>AD37-2-A</td> </tr> <tr> <td>G</td> <td>AD37N-2(Z)-A</td> </tr> <tr> <td>NPT</td> <td>AD37N-2(Z)-A</td> </tr> </table> 		Piping port thread type	(9) Part No.	Rc	AD37-2-A	G	AD37N-2(Z)-A	NPT	AD37N-2(Z)-A
	Piping port thread type	(9) Part No.																		
	Rc	AD37-D																		
	G	AD37N(Z)-D																		
NPT	AD37N(Z)-D																			
Piping port thread type	(9) Part No.																			
Rc	AD37-2-A																			
G	AD37N-2(Z)-A																			
NPT	AD37N-2(Z)-A																			
Semi-standard: 6 <table border="1"> <tr> <td>Piping port thread type</td> <td>(9) Part No.</td> </tr> <tr> <td>Rc</td> <td>AD37-6-A</td> </tr> <tr> <td>G</td> <td>AD37N-6(Z)-A</td> </tr> <tr> <td>NPT</td> <td>AD37N-6(Z)-A</td> </tr> </table>		Piping port thread type	(9) Part No.	Rc	AD37-6-A	G	AD37N-6(Z)-A	NPT	AD37N-6(Z)-A											
Piping port thread type	(9) Part No.																			
Rc	AD37-6-A																			
G	AD37N-6(Z)-A																			
NPT	AD37N-6(Z)-A																			
Option symbol	C ^{Note 1)}																			
Semi-standard symbol	8																			
Appearance and part No.	Semi-standard: 8 <table border="1"> <tr> <td>Piping port thread type</td> <td>(9) Part No.</td> </tr> <tr> <td>Rc</td> <td>AD37-8-A</td> </tr> <tr> <td>G</td> <td>AD37N-8(Z)-A</td> </tr> <tr> <td>NPT</td> <td>AD37N-8(Z)-A</td> </tr> </table> 		Piping port thread type	(9) Part No.	Rc	AD37-8-A	G	AD37N-8(Z)-A	NPT	AD37N-8(Z)-A	<p>Note 1) Minimum operating pressure is 0.15 MPa. Note 2) Part No. (9) includes Bowl seal (8). Refer to section [12. Disassembly Drawing] (P38). Note 3) "Z" in Part No. (9) indicates semi-standard specifications. The pressure unit: psi. The temperature unit: °F. Note 4) Refer to section [4. How to Order] (P10) for option and semi-standard symbols.</p>									
	Piping port thread type	(9) Part No.																		
Rc	AD37-8-A																			
G	AD37N-8(Z)-A																			
NPT	AD37N-8(Z)-A																			

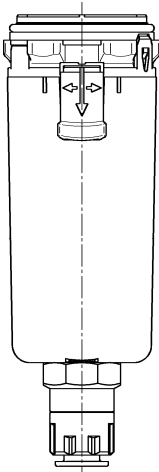
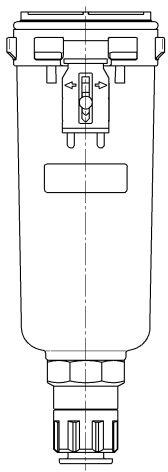
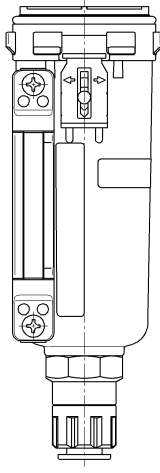
Option symbol	D ^{Note 1)}		D ^{Note 1)}																			
Semi-standard symbol	—	6	2																			
Appearance and part No.	Semi-standard: — <table border="1"> <tr> <td>Piping port thread type</td> <td>(9) Part No.</td> </tr> <tr> <td>Rc</td> <td>AD38-D</td> </tr> <tr> <td>G</td> <td>AD38N(-Z)-D</td> </tr> <tr> <td>NPT</td> <td>AD38N(-Z)-D</td> </tr> </table>		Piping port thread type	(9) Part No.	Rc	AD38-D	G	AD38N(-Z)-D	NPT	AD38N(-Z)-D		Semi-standard: 2 <table border="1"> <tr> <td>Piping port thread type</td> <td>(9) Part No.</td> </tr> <tr> <td>Rc</td> <td>AD38-2-A</td> </tr> <tr> <td>G</td> <td>AD38N-2(Z)-A</td> </tr> <tr> <td>NPT</td> <td>AD38N-2(Z)-A</td> </tr> </table>		Piping port thread type	(9) Part No.	Rc	AD38-2-A	G	AD38N-2(Z)-A	NPT	AD38N-2(Z)-A	
	Piping port thread type	(9) Part No.																				
Rc	AD38-D																					
G	AD38N(-Z)-D																					
NPT	AD38N(-Z)-D																					
Piping port thread type	(9) Part No.																					
Rc	AD38-2-A																					
G	AD38N-2(Z)-A																					
NPT	AD38N-2(Z)-A																					
Semi-standard: 6 <table border="1"> <tr> <td>Piping port thread type</td> <td>(9) Part No.</td> </tr> <tr> <td>Rc</td> <td>AD38-6-A</td> </tr> <tr> <td>G</td> <td>AD38N-6(Z)-A</td> </tr> <tr> <td>NPT</td> <td>AD38N-6(Z)-A</td> </tr> </table>		Piping port thread type	(9) Part No.	Rc	AD38-6-A	G	AD38N-6(Z)-A	NPT	AD38N-6(Z)-A													
Piping port thread type	(9) Part No.																					
Rc	AD38-6-A																					
G	AD38N-6(Z)-A																					
NPT	AD38N-6(Z)-A																					
Option symbol	D ^{Note 1)}																					
Semi-standard symbol	8																					
Appearance and part No.	Semi-standard: 8 <table border="1"> <tr> <td>Piping port thread type</td> <td>(9) Part No.</td> </tr> <tr> <td>Rc</td> <td>AD38-8-A</td> </tr> <tr> <td>G</td> <td>AD38N-8(Z)-A</td> </tr> <tr> <td>NPT</td> <td>AD38N-8(Z)-A</td> </tr> </table>				Piping port thread type	(9) Part No.	Rc	AD38-8-A	G	AD38N-8(Z)-A	NPT	AD38N-8(Z)-A										
	Piping port thread type	(9) Part No.																				
Rc	AD38-8-A																					
G	AD38N-8(Z)-A																					
NPT	AD38N-8(Z)-A																					
																						

Note 1) Minimum operating pressure is 0.1 MPa.

Note 2) Part No. (9) includes Bowl seal (8). Refer to section [12. Disassembly Drawing] (P38).

Note 3) "Z" in Part No. (9) indicates semi-standard specifications. The pressure unit: psi. The temperature unit: °F.

Note 4) Refer to section [4. How to Order] (P10) for option and semi-standard symbols.

3. Bowl assembly / auto drain for AWD40-D

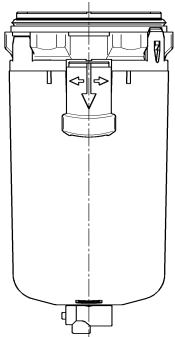
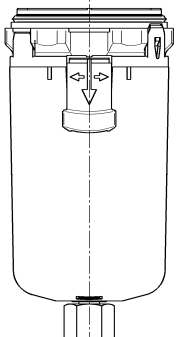
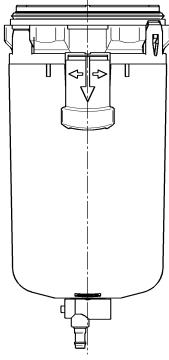
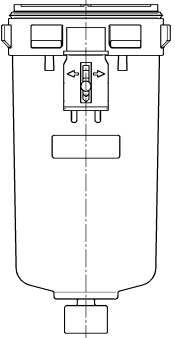
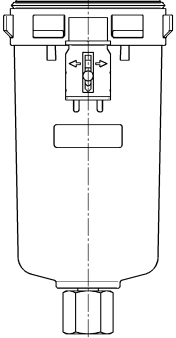
Option symbol	—		—	
Semi-standard symbol	—	6	J	6J
Appearance and part No.	Semi-standard: — (Standard)		Semi-standard: J	
	Piping port thread type	(9) Part No.	Piping port thread type	(9) Part No.
	Rc	C4SF-D	Rc	C4SF-J-D
	G	C4SF(-Z)-D	G	C4SFF-J-D
Semi-standard: 6		Semi-standard: 6J		
Piping port thread type	(9) Part No.	Piping port thread type	(9) Part No.	
Rc	C4SF-6-A	Rc	C4SF-6J-A	
G	C4SF-6(Z)-A	G	C4SFF-6J-A	
NPT	C4SF-6(Z)-A	NPT	C4SFN-6J(Z)-A	
Image				
Option symbol	—		—	
Semi-standard symbol	W	6W		
Appearance and part No.	Semi-standard: W			
	Piping port thread type	(9) Part No.		
	Rc	C4SF-W-D		
	G	C4SF-W(Z)-D		
Semi-standard: 6W				
Piping port thread type	(9) Part No.			
Rc	C4SF-6W-A			
G	C4SF-6W(Z)-A			
NPT	C4SF-6W(Z)-A			
Image				
Option symbol	—		—	
Semi-standard symbol	2		2J	
Appearance and part No.	Semi-standard: 2		Semi-standard: 2J	
	Piping port thread type	(9) Part No.	Piping port thread type	(9) Part No.
	Rc	C4SF-2-A	Rc	C4SF-2J-A
	G	C4SF-2(Z)-A	G	C4SFF-2J-A
Semi-standard: 2		Semi-standard: 2J		
Piping port thread type	(9) Part No.	Piping port thread type	(9) Part No.	
Rc	C4SF-2-A	Rc	C4SF-2J-A	
G	C4SF-2(Z)-A	G	C4SFF-2J-A	
NPT	C4SF-2(Z)-A	NPT	C4SFN-2J(Z)-A	
Image				

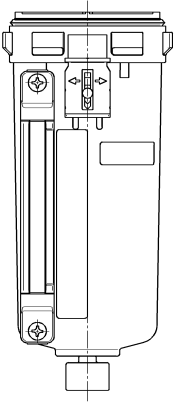
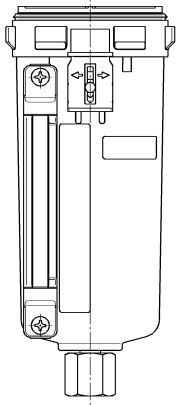
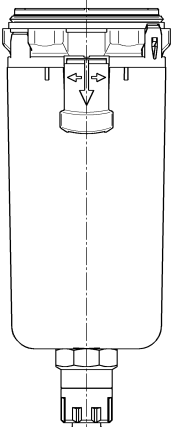
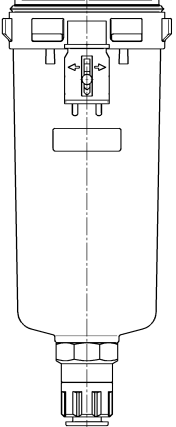
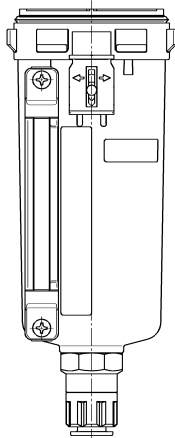
Option symbol	—		—																	
Semi-standard symbol	8		8J																	
Appearance and part No.	Semi-standard: 8 <table border="1"> <tr> <td>Piping port thread type</td> <td>(9) Part No.</td> </tr> <tr> <td>Rc</td> <td>C4LF-8-A</td> </tr> <tr> <td>G</td> <td>C4LF-8(Z)-A</td> </tr> <tr> <td>NPT</td> <td>C4LF-8(Z)-A</td> </tr> </table> 		Piping port thread type	(9) Part No.	Rc	C4LF-8-A	G	C4LF-8(Z)-A	NPT	C4LF-8(Z)-A	Semi-standard: 8J <table border="1"> <tr> <td>Piping port thread type</td> <td>(9) Part No.</td> </tr> <tr> <td>Rc</td> <td>C4LF-8J-A</td> </tr> <tr> <td>G</td> <td>C4LFF-8J-A</td> </tr> <tr> <td>NPT</td> <td>C4LFN-8J(Z)-A</td> </tr> </table> 		Piping port thread type	(9) Part No.	Rc	C4LF-8J-A	G	C4LFF-8J-A	NPT	C4LFN-8J(Z)-A
	Piping port thread type	(9) Part No.																		
Rc	C4LF-8-A																			
G	C4LF-8(Z)-A																			
NPT	C4LF-8(Z)-A																			
Piping port thread type	(9) Part No.																			
Rc	C4LF-8J-A																			
G	C4LFF-8J-A																			
NPT	C4LFN-8J(Z)-A																			
Option symbol	C Note 1)		C Note 1)																	
Semi-standard symbol	—	6	2																	
Appearance and part No.	Semi-standard: — <table border="1"> <tr> <td>Piping port thread type</td> <td>(9) Part No.</td> </tr> <tr> <td>Rc</td> <td>AD47-D</td> </tr> <tr> <td>G</td> <td>AD47N(-Z)-D</td> </tr> <tr> <td>NPT</td> <td>AD47N(-Z)-D</td> </tr> </table> 		Piping port thread type	(9) Part No.	Rc	AD47-D	G	AD47N(-Z)-D	NPT	AD47N(-Z)-D	Semi-standard: 2 <table border="1"> <tr> <td>Piping port thread type</td> <td>(9) Part No.</td> </tr> <tr> <td>Rc</td> <td>AD47-2-A</td> </tr> <tr> <td>G</td> <td>AD47N-2(Z)-A</td> </tr> <tr> <td>NPT</td> <td>AD47N-2(Z)-A</td> </tr> </table> 		Piping port thread type	(9) Part No.	Rc	AD47-2-A	G	AD47N-2(Z)-A	NPT	AD47N-2(Z)-A
	Piping port thread type	(9) Part No.																		
Rc	AD47-D																			
G	AD47N(-Z)-D																			
NPT	AD47N(-Z)-D																			
Piping port thread type	(9) Part No.																			
Rc	AD47-2-A																			
G	AD47N-2(Z)-A																			
NPT	AD47N-2(Z)-A																			
Option symbol	C Note 1)																			
Semi-standard symbol	8																			
Appearance and part No.	Semi-standard : 8 <table border="1"> <tr> <td>Piping port thread type</td> <td>(9) Part No.</td> </tr> <tr> <td>Rc</td> <td>AD47-8-A</td> </tr> <tr> <td>G</td> <td>AD47N-8(Z)-A</td> </tr> <tr> <td>NPT</td> <td>AD47N-8(Z)-A</td> </tr> </table> 		Piping port thread type	(9) Part No.	Rc	AD47-8-A	G	AD47N-8(Z)-A	NPT	AD47N-8(Z)-A	<p>Note 1) Minimum operating pressure is 0.15 MPa. Note 2) Part No. (9) includes Bowl seal (8). Refer to section [12. Disassembly Drawing] (P38). Note 3) "Z" in Part No. (9) indicates semi-standard specifications. The pressure unit: psi. The temperature unit: °F. Note 4) Refer to section [4. How to Order] (P10) for option and semi-standard symbols.</p>									
	Piping port thread type	(9) Part No.																		
Rc	AD47-8-A																			
G	AD47N-8(Z)-A																			
NPT	AD47N-8(Z)-A																			

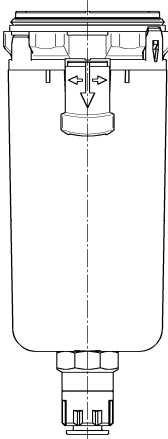
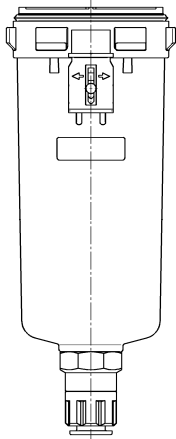
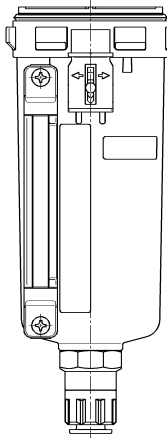
Option symbol	D ^{Note 1)}		D ^{Note 1)}		
Semi-standard symbol	—		6		
Appearance and part No.	Semi-standard: —			Semi-standard: 2	
	Piping port thread type	(9) Part No.		Piping port thread type	(9) Part No.
	Rc	AD48-D		Rc	AD48-2-A
	G	AD48N(-Z)-D		G	AD48N-2(Z)-A
Semi-standard: 6			Semi-standard: 2		
Piping port thread type	(9) Part No.		Piping port thread type	(9) Part No.	
Rc	AD48-6-A		Rc	AD48-2-A	
G	AD48N-6(Z)-A		G	AD48N-2(Z)-A	
NPT	AD48N-6(Z)-A	NPT	AD48N-2(Z)-A	NPT	AD48N-2(Z)-A
Option symbol	D ^{Note 1)}				
Semi-standard symbol	8				
Appearance and part No.	Semi-standard: 8				
	Piping port thread type	(9) Part No.			
	Rc	AD48-8-A			
	G	AD48N-8(Z)-A			
NPT	AD48N-8(Z)-A				

Note 1) Minimum operating pressure is 0.1 MPa.

Note 2) Part No. (9) includes Bowl seal (8). Refer to section [12. Disassembly Drawing] (P38).

Note 3) "Z" in Part No. (9) indicates semi-standard specifications. The pressure unit: psi. The temperature unit: °F.

Note 4) Refer to section [4. How to Order] (P10) for option and semi-standard symbols.

8. Assembly of Optional Parts

8-1. Bracket (Panel mount)

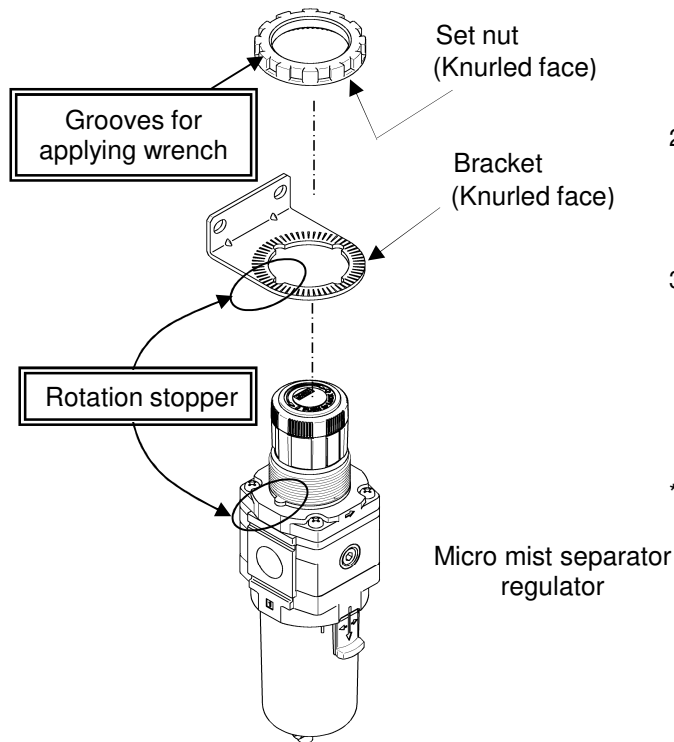

- 1) Bracket mounting
Mount the bracket to the micro mist separator regulator as shown in the picture. Assemble so that the rotation stopper of the micro mist separator regulator and the bracket are engaged properly.
- 2) Secure with the set nut
Ensure that the knurled faces of the bracket and the set nut are facing each other.
- 3) Tightening
Turn the set nut while the micro mist separator regulator is aligned correctly with the bracket. The knurling of the bracket and set nut stops loosening of the screw. Usually, these can be tightened adequately by hand. (Extra tightening is recommended for panel mounting).

* When retightening
Please use a hook wrench on the grooves of the set nut. After hand tightening, follow the values in the table below for retightening.

Model	Tool size	Amount of retightening	Reference torque
AWD20-D	34/38	2 to 5 notch	2.0+/-0.2 N · m
AWD30-D	52/55		3.5+/-0.3 N · m
AWD40-D	52/55		4.0+/-0.4 N · m

8-2. Pressure gauge (round type)

Micro mist separator regulator

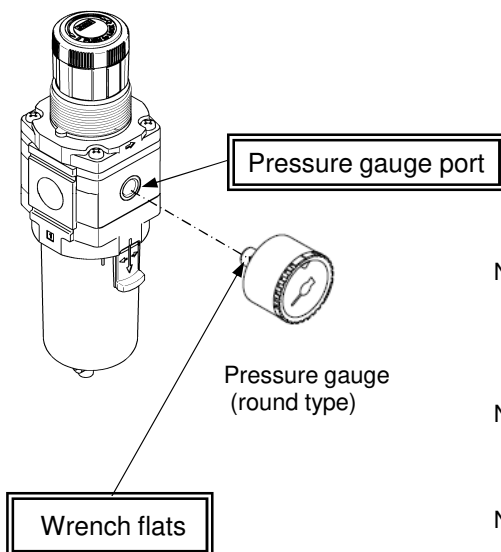

- 1) Pressure gauge mounting (round type)
Before mounting the pressure gauge onto the pressure gauge port of the micro mist separator regulator, confirm that sealing material has been applied to the pressure gauge. Please refer to "Piping" on page 7 when using sealing tape.

Wrench size

Model	Tool size
AWD20-D	14
AWD30-D	
AWD40-D	

- Note 1) Positioning of pressure gauge
Adjust the pressure gauge position by tightening it. Adjustment in loosening direction may cause air leakage.
- Note 2) No plug is mounted onto the pressure gauge port of product with a round type pressure gauge.
- Note 3) Torque control
Please use the value in the torque table described in "Piping" on page 7 when tightening.

9. Operation and Adjustment

9-1. Pressure regulation

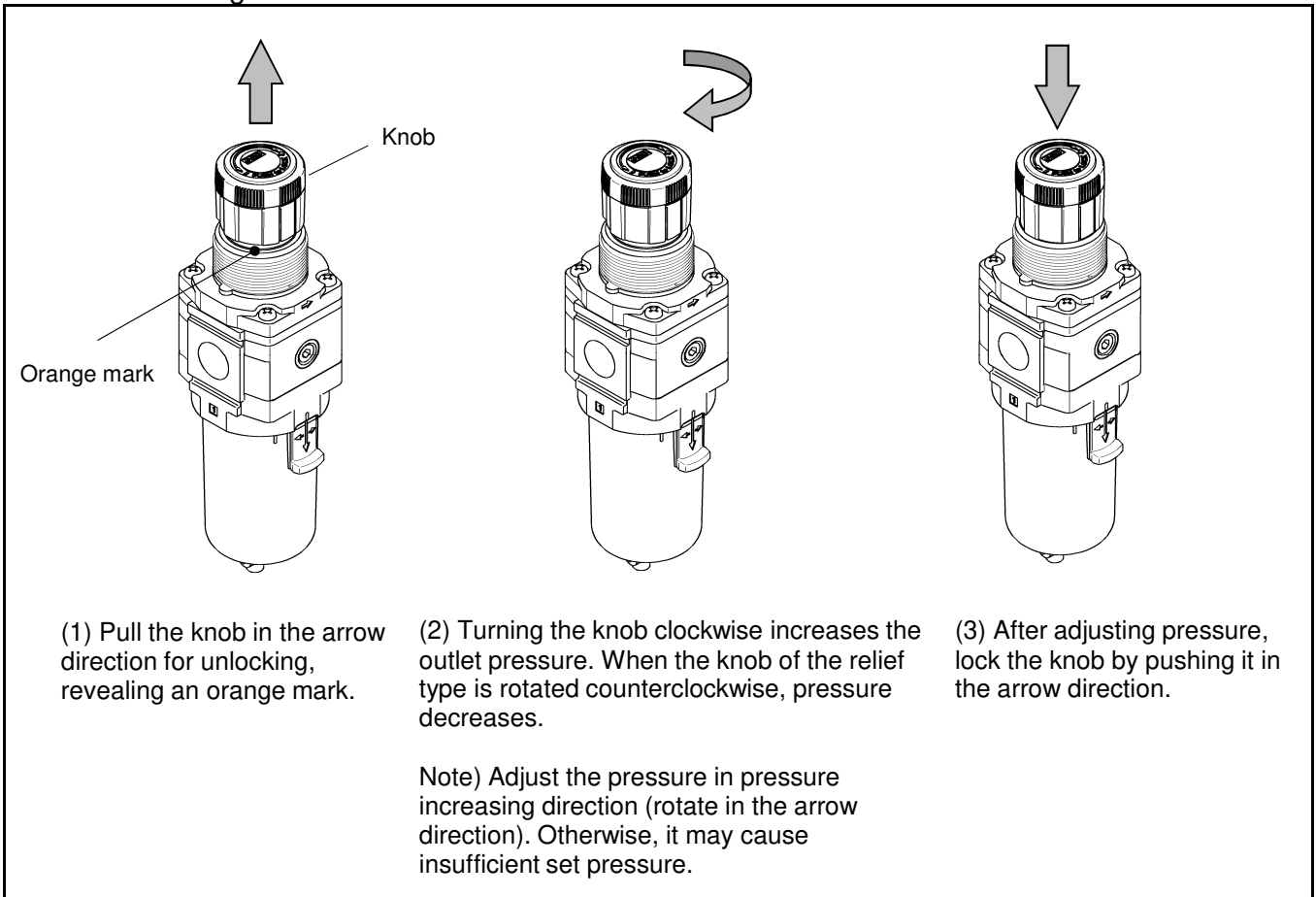

9-2. Indicator adjustment of the square embedded type pressure gauge

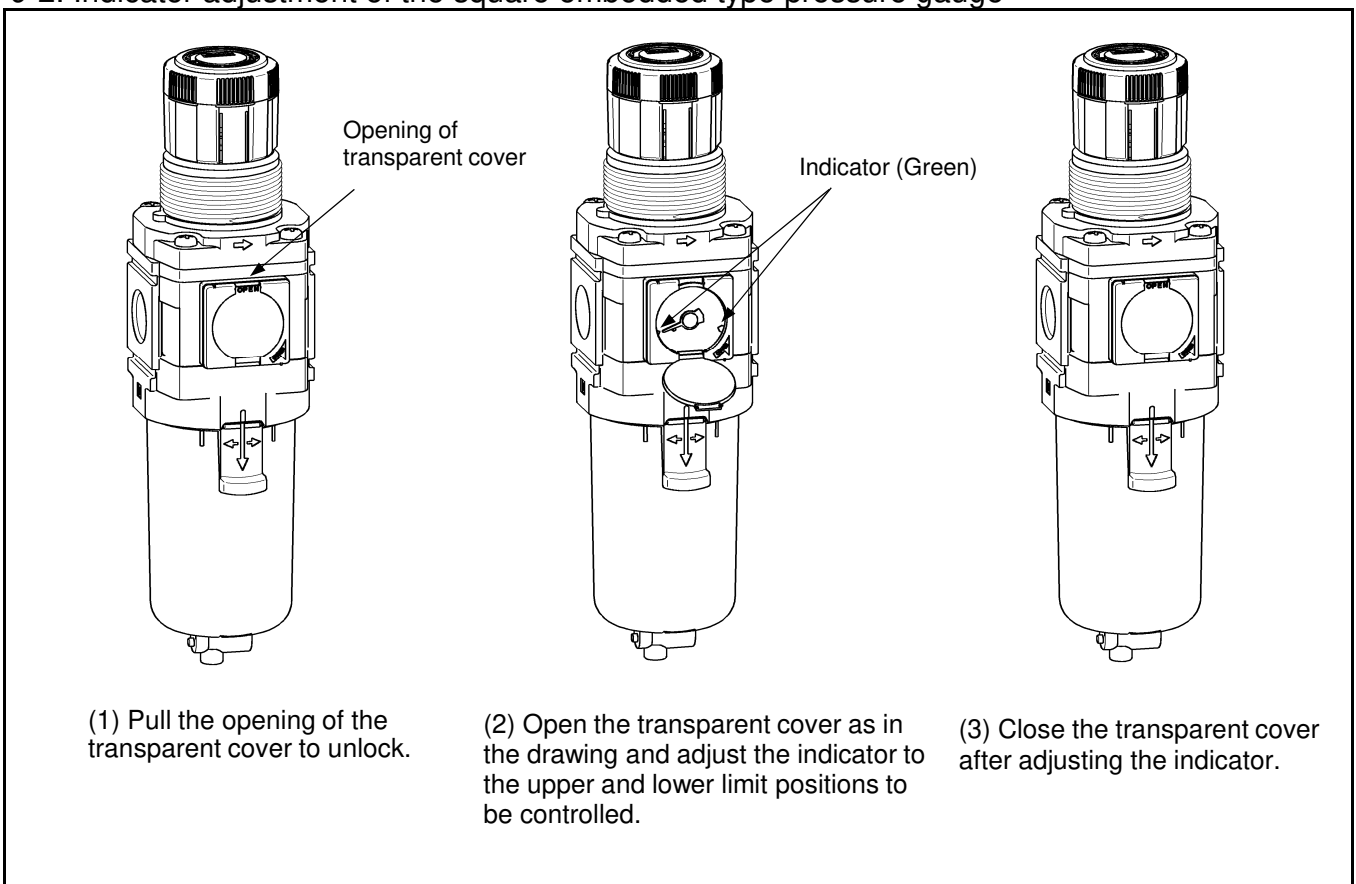

9-3. Discharge from the product with drain cock

- Pressurize the inside of the micro mist separator regulator when discharging drain. Drain will not be discharged properly if not pressurized.
- Drain discharge mechanism is different depending on the bowl assembly. Check the bowl assembly and discharge the drain following the method below.
 Rotation type: After discharging the drain, tighten the drain cock to the opposite direction by hand until the seal inside seals correctly. Use of a tool can damage the product.

AWD20-D: Drain cock (rotation type)
(Polycarbonate bowl/ Nylon bowl)

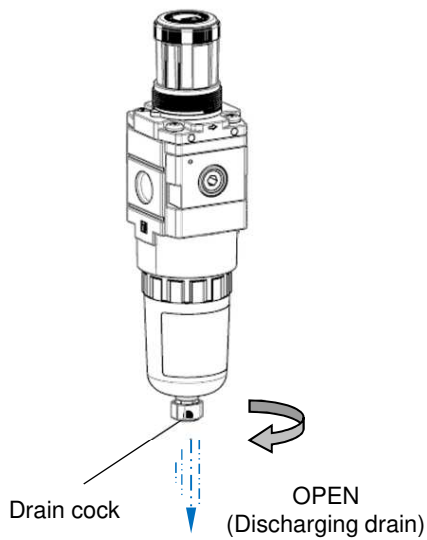

AWD30-D/ AWD40-D: Drain cock/ With barb fitting (push type)
(Polycarbonate bowl/ Nylon bowl)

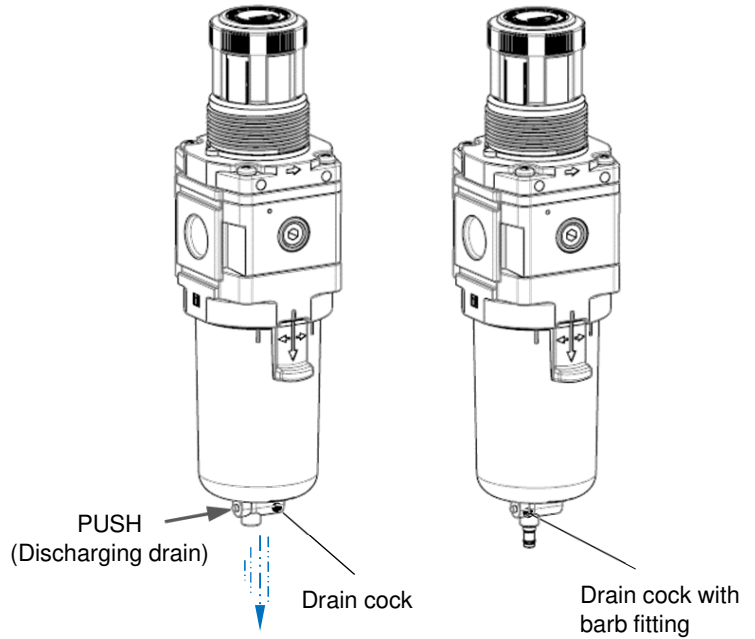

AWD20-D: Drain cock (push type)
(Metal bowl)

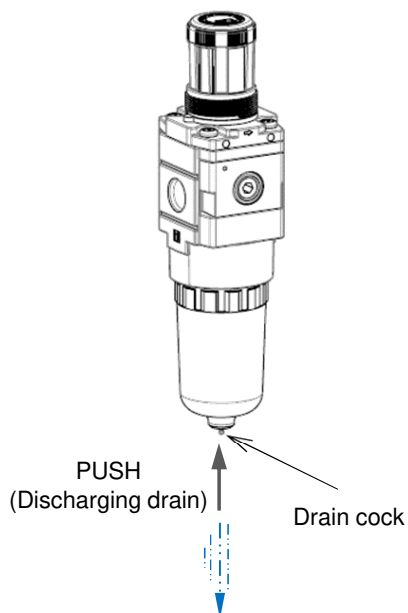

AWD30-D/ AWD40-D: Drain cock (rotation type)
(Metal bowl/ Metal bowl with level gauge)

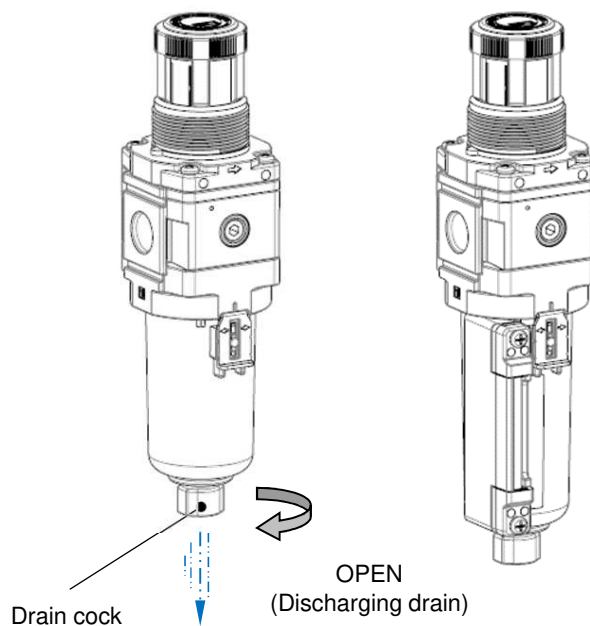

9-4. Manual drain discharge from the auto drain

- Pressurize the inside of the micro mist separator regulator when discharging drain. Drain will not be discharged properly if not pressurized.
- To discharge the auto drain manually, follow the procedure below. After discharging the drain, rotate the cock to the opposite direction by hand to close the drain valve. Use of a tool can damage the product.

AWD20-D: Auto drain

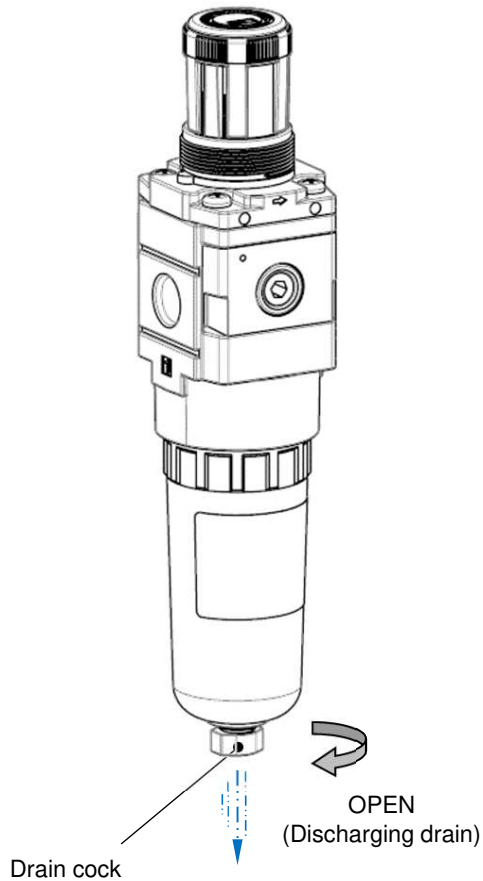

AWD30-D/ AWD40-D: Auto drain

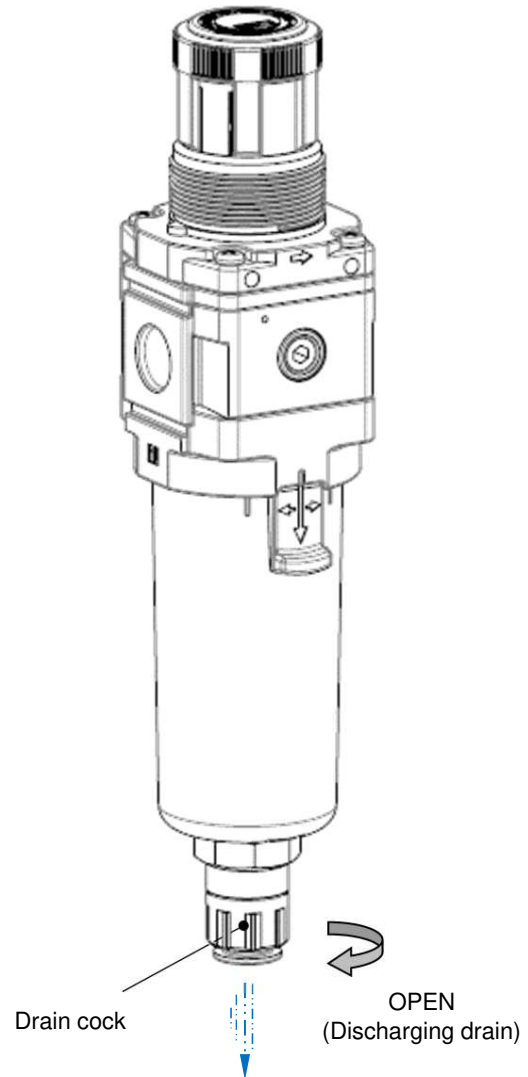

10. Trouble Shooting

Refer to sections [11. How to Replace the Components] (P28-37) and [12. Disassembly Drawing] (P38-39).

Trouble		Possible cause	Countermeasure	Page for reference
Category	Failure			
Flow rate	As pressure drop is large, fluid does not flow.	1. Clog of the element.	Replace the element.	P31-32
Pressure	The pressure can not be adjusted.	1. Air pressure is not supplied to the inlet.	Check the supply pressure. Ensure that the supply side ball valve is opened.	-
		2. The product is installed opposite to the flow direction.	Install the product correctly after confirming the direction of flow. "1" indicates the IN and "2" indicates the OUT.	P6
		3. Pressure regulating spring is damaged.	Replace the pressure regulating spring.	P28
		4. Valve spring is damaged.	Replace the valve spring.	P33-34
		5. Foreign materials caught in the rubber seat of the valve or the O-ring on the valve sliding part.	Replace the valve assembly.	P33-34
		6. Seating part of the valve is damaged.	Replace the valve assembly.	P33-34
	The set pressure does not become zero even when the knob is loosened.	1. Foreign materials caught in the seating part or O-ring of the valve.	Remove the valve assembly and eliminate foreign materials. When the condition is not improved, replace the valve assembly.	P33-34
		2. Rubber seat of the valve is damaged.	Replace the valve assembly.	P33-34
		3. Valve spring is damaged.	Replace the valve spring.	P33-34
		4. The valve is fixed in an open position.	Clean the valve sliding surface of O-ring and apply grease additionally.	P33-34
Air leakage	Air leakage from the bonnet exhaust port.	1. The product is installed opposite to the flow direction.	Install the product correctly after confirming the direction of flow.	P6
		2. Diaphragm is damaged.	Replace the diaphragm assembly.	P28
		3. Foreign materials caught in seating part of the exhaust valve.	Clean the seating part of the relief valve or replace the diaphragm assembly.	P28
		4. Foreign materials caught in the seating part or O-ring of the valve.	Remove the valve guide to clean the valve, valve seating part and valve O-ring. And then, apply grease to the O-ring and sliding part of the valve.	P33-34
		5. Rubber seat of the valve assembly is damaged.	Replace the valve assembly.	P33-34

Note) Fluorine grease is recommended when applying additional grease.

Refer to sections [11. How to Replace the Components] (P28-37) and [12. Disassembly Drawing] (P38-39).

Trouble		Possible cause	Countermeasure	Page for reference
Category	Failure			
Air leakage	Air leakage from the bonnet exhaust port.	6. Back pressure exceeding the set pressure is applied to the downstream.	Revise the air circuit so that back pressure does not exceed the set pressure.	-
	Air leakage from between the bonnet and the body.	1. Loosened bonnet screws.	Fasten the bonnet.	P28
		2. Diaphragm is damaged.	Replace the diaphragm assembly.	P28
	Air leakage from between the body and the bowl.	1. Bowl seal is damaged.	Replace the bowl seal. Grease up before replacing the bowl seal. <small>Note)</small>	P29-30
	Air leakage from the bowl.	1. Bowl is damaged.	Replace the bowl assembly. (If the solvent is considered to be harmful, replacement to the metal bowl is recommended.)	P29-30
	Air leakage from the drain cock.	1. Foreign matter caught in the valve of the drain cock.	Open the drain cock for a few seconds for blowing.	P24-25
		2. Seating part of the drain cock is damaged.	Replace the bowl assembly.	P29-30
	Drain or air continues blowing out from the drain discharge of the float type auto drain.	1. Low supply pressure	Confirm the minimum operating pressure of the auto drain.	P5 P14-21
		2. The product is not mounted correctly.	Install the drain exhaust so that it will face vertically downward.	P6
		3. Foreign matter is caught in the main valve of the auto drain.	Eliminate the dirt by manual discharge.	P24-25
		4. Main valve of the auto drain is broken.	Replace the bowl assembly.	P29-30
		5. Drain piping is long, or I.D. of the piping is small. (Back pressure is applied.)	Be sure to connect the appropriate piping for drain.	P7
		6. Drain discharging part and bowl seat are damaged.	Replace the bowl assembly.	P29-30
Operability	Drain is not discharging when the drain	1. Blockage of outlet of the drain cock due to solid foreign matter etc.	Replace the bowl assembly.	P29-30
	Too much drain comes from the piping on outlet side.	1. Drain level reaches the element assembly .	Open the drain cock for discharging and replace the element assembly.	P24-25 P31-32

Note) Fluorine grease is recommended when applying additional grease.

11. How to Replace the Components



Warning

Before replacement, make sure that no pressure remains in the equipment.

Also, make sure to loosen the knob of the mist separator regulator so that the set pressure is zero.

After replacement, confirm that the product satisfies specific functions and no external leakage occurs before operating it.

11-1. Diaphragm Assembly Replacement

Applicable model	Work category	Procedure	Tool	Criteria				
AWD20 AWD30 AWD40	Disassembly	1) Loosen the knob completely before disassembly.	—	—				
		2) Remove the 4 screws and remove the bonnet.	AWD20/ AWD30/ AWD40 Phillips screwdriver	—				
		3) Remove the pressure regulating screw assembly, pressure regulating spring, and diaphragm assembly in that order.	—	—				
	Assembly	4) Assemble the diaphragm assembly, pressure regulating spring, and then pressure regulating screw assembly.	—	Direction of diaphragm assembly and pressure regulating screw assembly				
		5) Assemble the bonnet to the body. While the convex side of the bonnet is facing the IN side, mount it onto the body. Then tighten the 4 mounting screws temporarily before tightening them diagonally and evenly to fix the bonnet.	AWD20/ AWD30/ AWD40 Phillips screwdriver	Tightening torque: <table border="1"> <tr> <td>AWD20-D</td> <td>2.35+/- 0.3 N m</td> </tr> <tr> <td>AWD30-D</td> <td></td> </tr> <tr> <td>AWD40-D</td> <td>3.5+/- 0.3 N m</td> </tr> </table>	AWD20-D	2.35+/- 0.3 N m	AWD30-D	
AWD20-D	2.35+/- 0.3 N m							
AWD30-D								
AWD40-D	3.5+/- 0.3 N m							

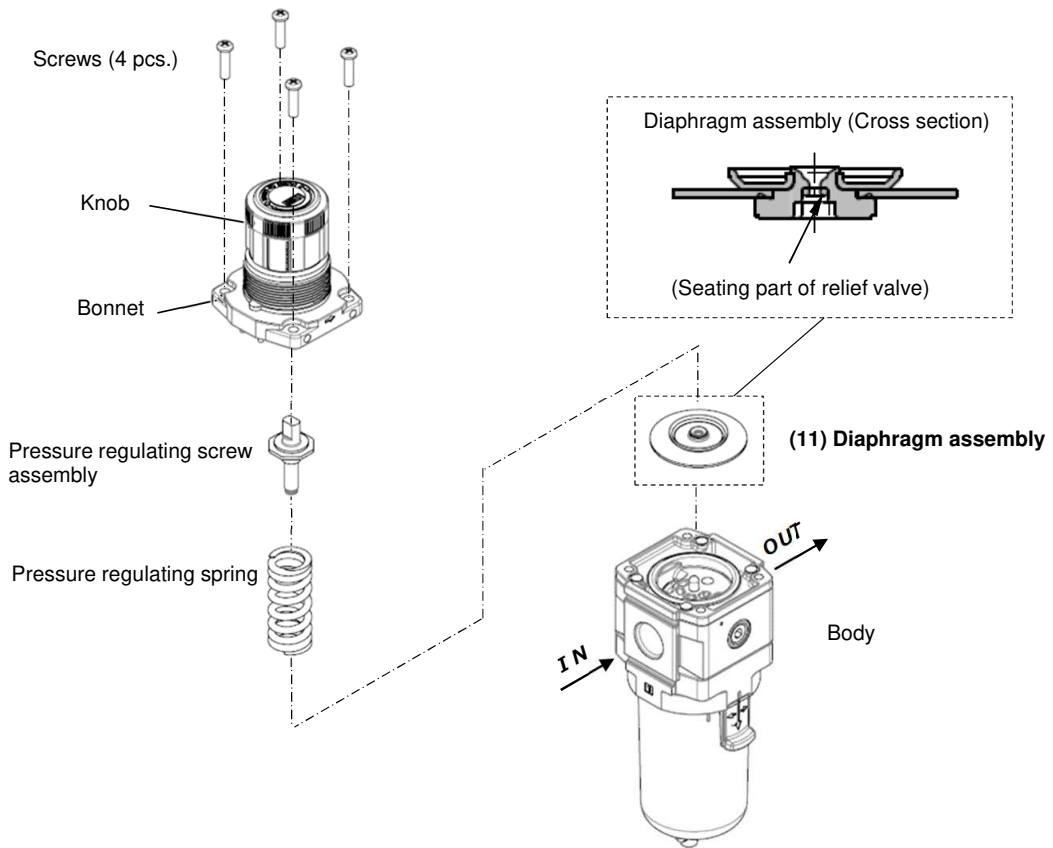

11-2. Bowl Assembly Replacement

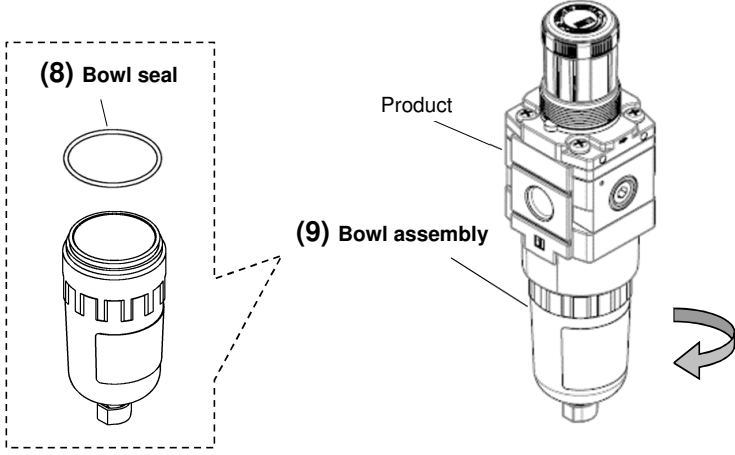
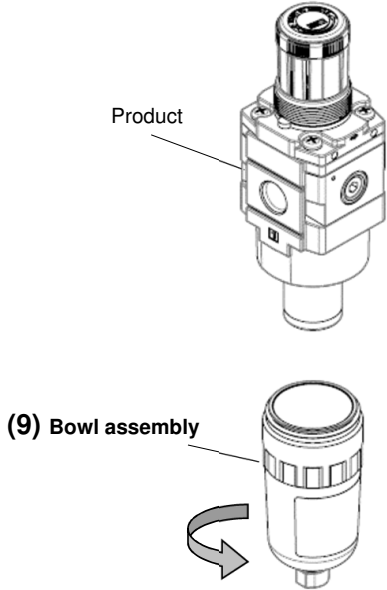
Applicable model	Work category	Procedure	Tool	Criteria
AWD20	Disassembly	1) Remove the bowl assembly from the product. If the bowl assembly is tightened too much to be removed, use a hook spanner until it can be loosened by hand.	Spanner specified for SMC Product No.: 1129129	—
				
Work category	Procedure	Tool	Criteria	
Assembly	2) Screw the bowl assembly into the product. Tighten it referring to the specified torque.	—	Reference tightening torque: 2.1 N m	
				

Applicable model	Work category	Procedure	Tool	Criteria
AWD30 AWD40	Disassembly	<p>1) Remove the bowl assembly from the product. While the lock button is held down, rotate the bowl assembly by approx. 30 degrees so that the mating marks of the body and bowl assembly meet each other. Then remove the bowl assembly by pulling it downward.</p>	-	-
<p>(8) Bowl seal</p> <p>(9) Bowl assembly</p> <p>Product</p> <p>Lock button</p> <p>Align the mating mark</p> <p>Mating mark of the body</p> <p>Mating mark of the bowl assembly</p> <p>[Step 1] Rotate 30 degrees</p> <p>[Step 2] Pull downward</p>				
Work category	Procedure	Tool	Criteria	
Assembly	<p>2) Mount the bowl assembly to the product and rotate the bowl assembly until the lock button is locked in position as shown in the figure below.</p>	-	-	
<p>Product</p> <p>(9) Bowl assembly</p> <p>Lock button</p> <p>[Step 2] Rotate 30 degrees</p> <p>[Step 1] Insert upward</p> <p>Caution</p> <p>Make sure that the lock button is locked to the flute of the product before pressurising it.</p>				

11-3. Element Replacement

Applicable model	Work category	Procedure	Tool	Criteria
AWD20	Disassembly	<p>1) Remove the bowl assembly referring to the section [11-2. Bowl Assembly Replacement] (P29-30). After that, remove the element assembly by rotating it counterclockwise using a spanner.</p>	Spanner nominal size: 7	-
Work category	Procedure	Tool	Criteria	
Assembly	<p>1) Mount the element assembly by rotating it clockwise using a spanner. Tighten the element assembly referring to the torque specified on the right. Mount the the bowl assembly referring to the section [11-2. Bowl Assembly Replacement] (P29-30).</p>	Spanner nominal size: 7	Tightening torque: 0.5+/-0.05 N m	

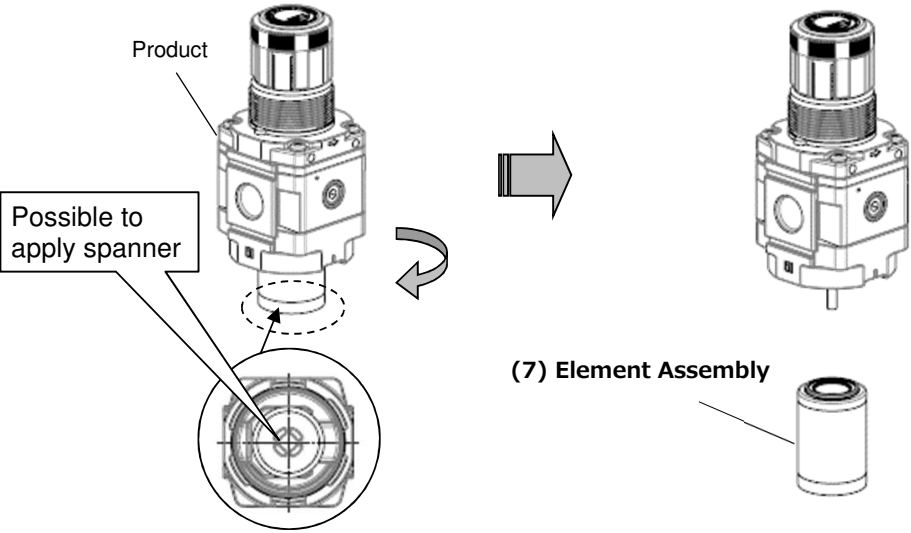
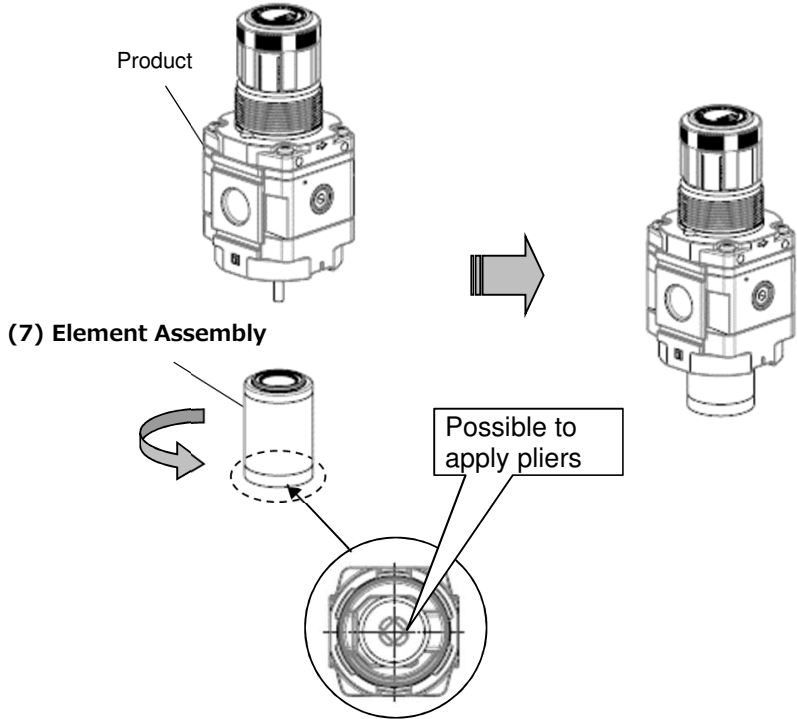
Applicable model	Work category	Procedure	Tool	Criteria
AWD30 AWD40	Disassembly	1) Remove the bowl assembly referring to the section [11-2. Bowl Assembly Replacement] (P29-30). After that, remove the element assembly by rotating it counterclockwise using round nose pliers.	Round nose pliers	—
				
	Assembly	1) Mount the element assembly by rotating it clockwise using round nose pliers. Tighten the element assembly referring to the torque specified on the right. Mount the bowl assembly referring to the section [11-2. Bowl Assembly Replacement] (P29-30).	Round nose pliers	Tightening torque: AWD30-D: 1.5+/-0.2 N m AWD40-D: 2+/-0.2 N m
				

11-4. Valve Assembly Replacement

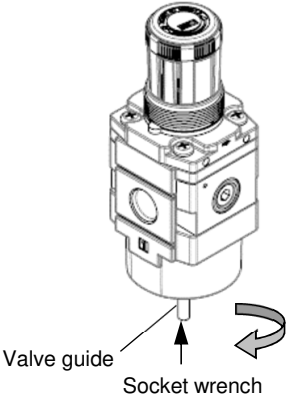
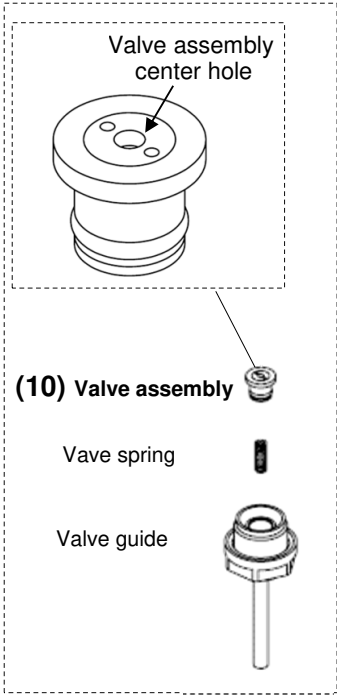
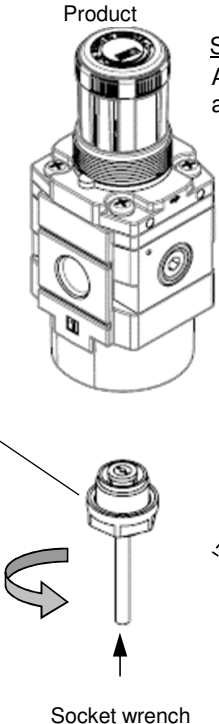
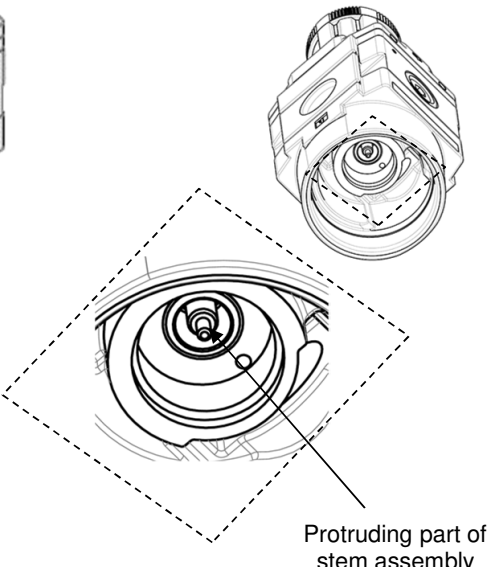
Applicable model	Work category	Procedure	Tool	Criteria	
AWD20	Disassembly	1) Remove the bowl assembly and element referring to sections [11-2. Bowl Assembly Replacement] (P29-30) and [11-3. Element Replacement] (P31-32). Rotate the valve guide in the arrow direction to remove, taking care not to lose the valve spring.	Socket wrench nominal size: 18	—	
 <p>Valve guide</p> <p>Socket wrench</p>					
Work category	Procedure	Tool	Criteria		
Assembly	2) Mount the valve spring and valve assembly on the valve guide as shown in the drawing. Rotate the valve guide in the arrow direction to mount the valve guide to the product. Assemble the element and the bowl assembly referring to sections [11-3. Element Replacement] (P31-32) and [11-2. Bowl Assembly Replacement] (P29-30).	Socket wrench nominal size: 18	Tightening torque: 0.8+/-0.1 N m		
<div style="display: flex; justify-content: space-between;"> <div style="width: 45%;">  <p>Valve assembly center hole</p> <p>(10) Valve assembly</p> <p>Valve spring</p> <p>Valve guide</p> </div> <div style="width: 45%;"> <p>Product</p>  <p>Socket wrench</p> </div> <div style="width: 45%;"> <p><u>Supplement</u></p> <p>Align the protruding part of the stem assembly and the center hole of the valve assembly.</p>  <p>Protruding part of stem assembly</p> </div> </div>					

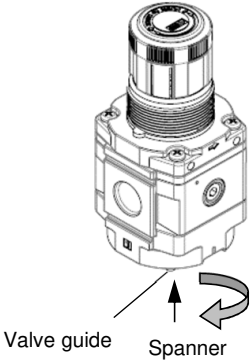
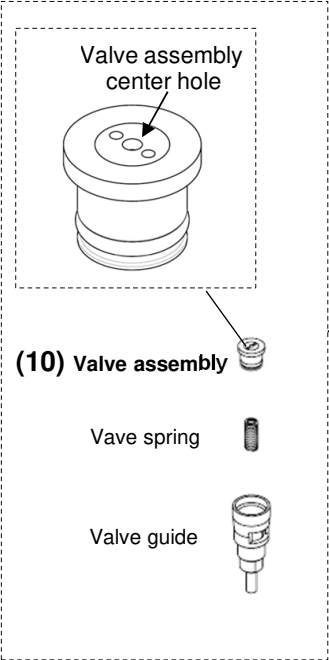
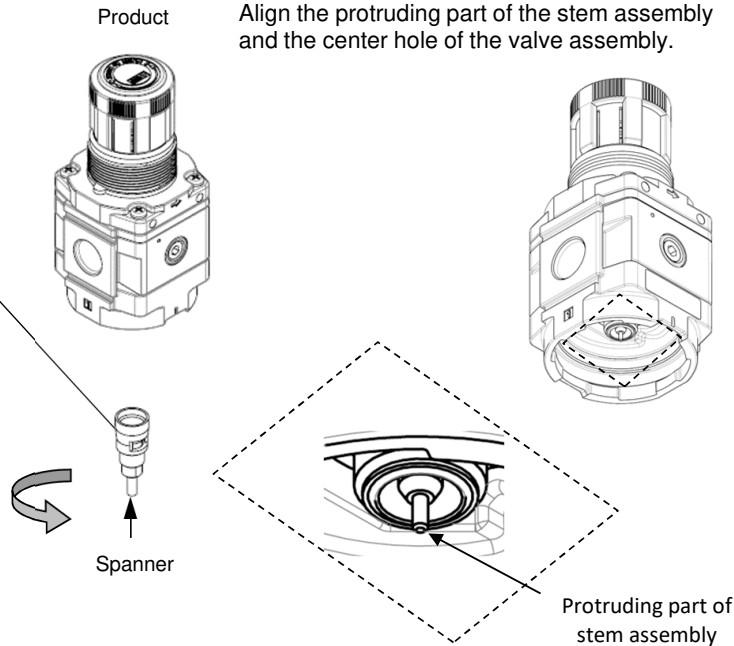
Applicable model	Work category	Procedure	Tool	Criteria							
AWD30 AWD40	Disassembly	1) Remove the bowl assembly and element referring to sections [11-2. Bowl Assembly Replacement] (P29-30) and [11-3. Element Replacement] (P31-32). Rotate the valve guide in the arrow direction to remove, taking care not to lose the valve spring.	Spanner <table border="1" data-bbox="927 264 1198 331"> <tr> <td>AWD30-D</td> <td>Nominal size: 8</td> </tr> <tr> <td>AWD40-D</td> <td>Nominal size: 12</td> </tr> </table>	AWD30-D	Nominal size: 8	AWD40-D	Nominal size: 12	-			
AWD30-D	Nominal size: 8										
AWD40-D	Nominal size: 12										
 <p>Valve guide Spanner</p>											
Work category	Procedure	Tool	Criteria								
Assembly	2) Mount the valve spring and valve assembly on the valve guide as shown in the drawing. Rotate the valve guide in the arrow direction to mount the valve guide to the product. Assemble the element and the bowl assembly referring to sections [11-3. Element Replacement] (P31-32) and [11-2. Bowl Assembly Replacement] (P29-30).	Spanner <table border="1" data-bbox="927 1010 1198 1077"> <tr> <td>AWD30-D</td> <td>Nominal size: 8</td> </tr> <tr> <td>AWD40-D</td> <td>Nominal size: 12</td> </tr> </table>	AWD30-D	Nominal size: 8	AWD40-D	Nominal size: 12	Tightening torque: <table border="1" data-bbox="1203 1010 1528 1077"> <tr> <td>AWD30-D</td> <td>2.35+/-0.3 N · m</td> </tr> <tr> <td>AWD40-D</td> <td>3.5+/-0.3 N · m</td> </tr> </table>	AWD30-D	2.35+/-0.3 N · m	AWD40-D	3.5+/-0.3 N · m
AWD30-D	Nominal size: 8										
AWD40-D	Nominal size: 12										
AWD30-D	2.35+/-0.3 N · m										
AWD40-D	3.5+/-0.3 N · m										
<div style="display: flex; justify-content: space-between;"> <div style="width: 45%;">  <p>(10) Valve assembly</p> <p>Valve spring</p> <p>Valve guide</p> </div> <div style="width: 45%;"> <p>Supplement Align the protruding part of the stem assembly and the center hole of the valve assembly.</p>  <p>Product</p> <p>Spanner</p> <p>Protruding part of stem assembly</p> </div> </div>											

11-5. Square Embedded Type Pressure Gauge

Applicable model	Work category	Procedure	Tool	Criteria
AWD20 AWD30 AWD40	Disassembly	1) Remove the pressure gauge cover assembly. Rotate the pressure gauge cover assembly 15 degrees in the arrow direction (counterclockwise) and pull it out.	—	—
		2) Remove the pressure gauge. Remove the 2 mounting screws and remove the pressure gauge. The body cover comes out together. Please take care not missing it.	Phillips screwdriver	—
	Assembly	3) Confirm that the O-ring is mounted onto the pressure gauge. When the O-ring comes out or is left on the filter regulator, mount the O-ring to the pressure gauge correctly.	-	Presence of the O-ring
		4) Assemble the pressure gauge. Mount the pressure gauge to the filter regulator with the mounting screws and tighten the screws referring to the tightening torque specified in the right column.	Phillips screwdriver	Tightening torque: 0.85+/- 0.05 N m
		5) Mount the pressure gauge cover assembly. Set the pressure gauge cover assembly with its arrow on the lower right corner. Mate the 2 fingers of the pressure gauge cover assembly with the 2 finger slits of the pressure gauge, and rotate the pressure gauge cover assembly 15 degrees to the opposite direction of the arrow (clockwise).	—	—

Note) Applicable to the product with square embedded type pressure gauge (E).

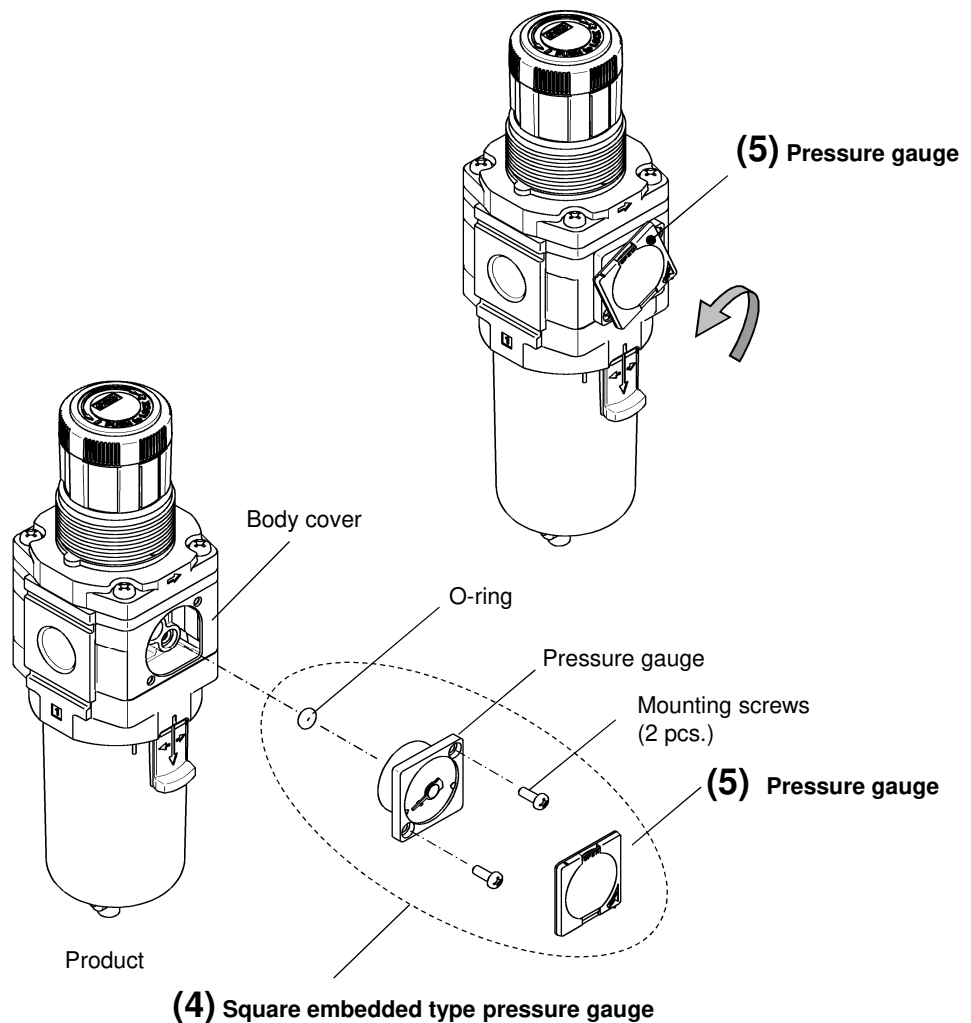

11-6. Blanking Plate Assembly Replacement

Applicable model	Work category	Procedure	Tool	Criteria
AWD20 AWD30 AWD40	Disassembly	1) Remove the blanking plate. Remove the 2 mounting screws and remove the blanking plate. The body cover (AWD30-D, AWD40-D) comes out together. Please take care not missing it.	Phillips screwdriver	—
	Assembly	2) Confirm that the O-ring is mounted onto the blanking plate. When the O-ring comes out or is left on the filter regulator, mount the O-ring to the blanking plate correctly.	—	Presence of the O-ring
		3) Assemble the blanking plate. Mount the blanking plate to the product, over the body cover, with the mounting screws and tighten them referring to the tightening torque specified in the right column.	Phillips screwdriver	Tightening torque: 0.6+/- 0.05 N m

Note) Applicable to the product with square embedded type pressure gauge (E) or digital pressure switch (E1 to E4).

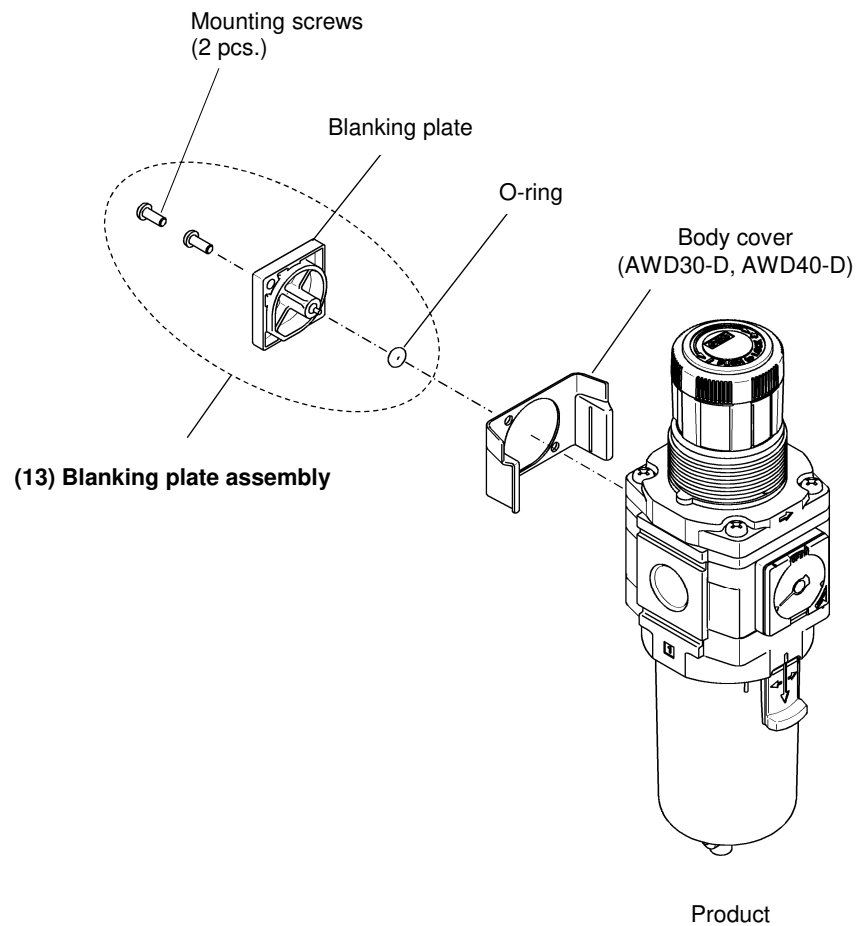

11-7. Plug Assembly Replacement

Applicable model	Work category	Procedure	Tool	Criteria
AWD20 AWD30 AWD40	Disassembly	1) Remove the plug assembly.	Hexagon wrench (Nominal size: 4)	—
	Assembly	2) Mount the plug assembly.	Hexagon wrench (Nominal size: 4)	Tightening torque: 0.6+/- 0.05 N m

Note) Applicable to the product without pressure gauge.

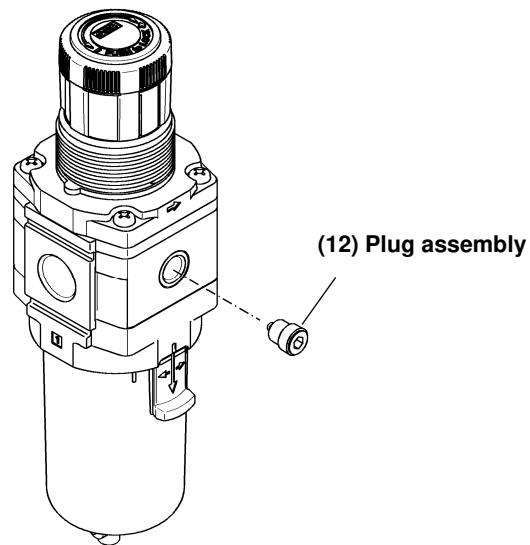

Micro mist separator regulator
(AWD20-D / AWD30-D / AWD40-D)

12. Disassembly Drawing

12-1. AWD20-D / AWD30-D / AWD40-D

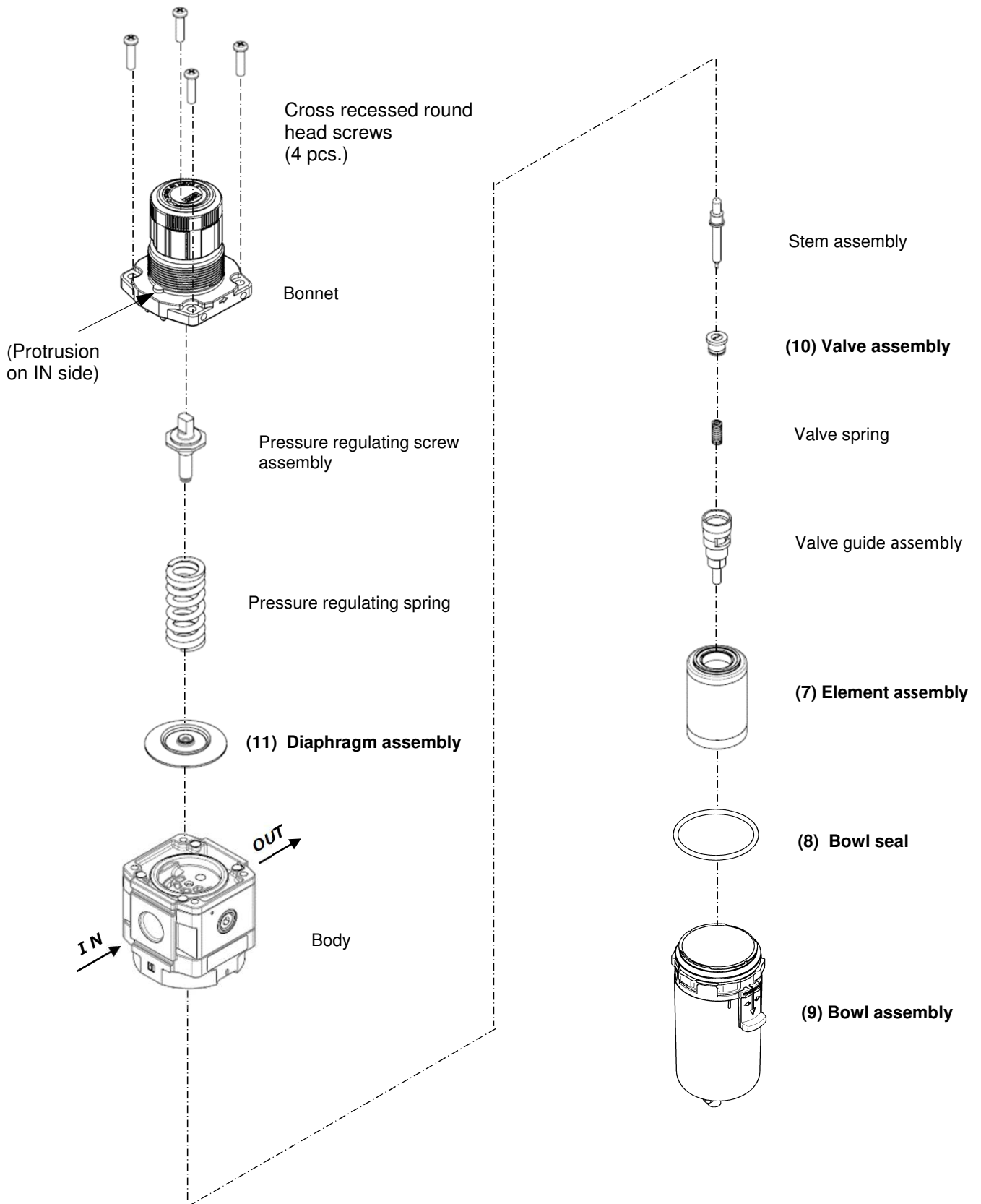

12-2. Disassembly Drawing of the Pressure Gauge Port

[Applicable model: without pressure gauge / with pressure gauge (round type)]

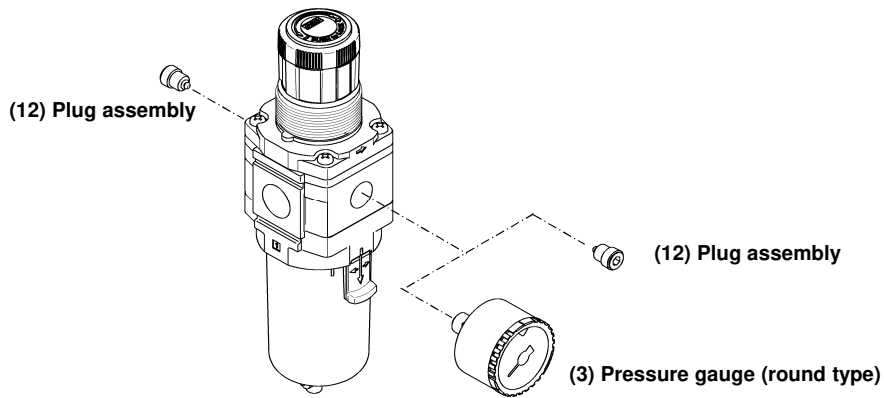

Micro mist separator regulator

12-3. Disassembly Drawing of the Pressure Gauge Port

[Applicable model: with square embedded type pressure gauge / with digital pressure switch]

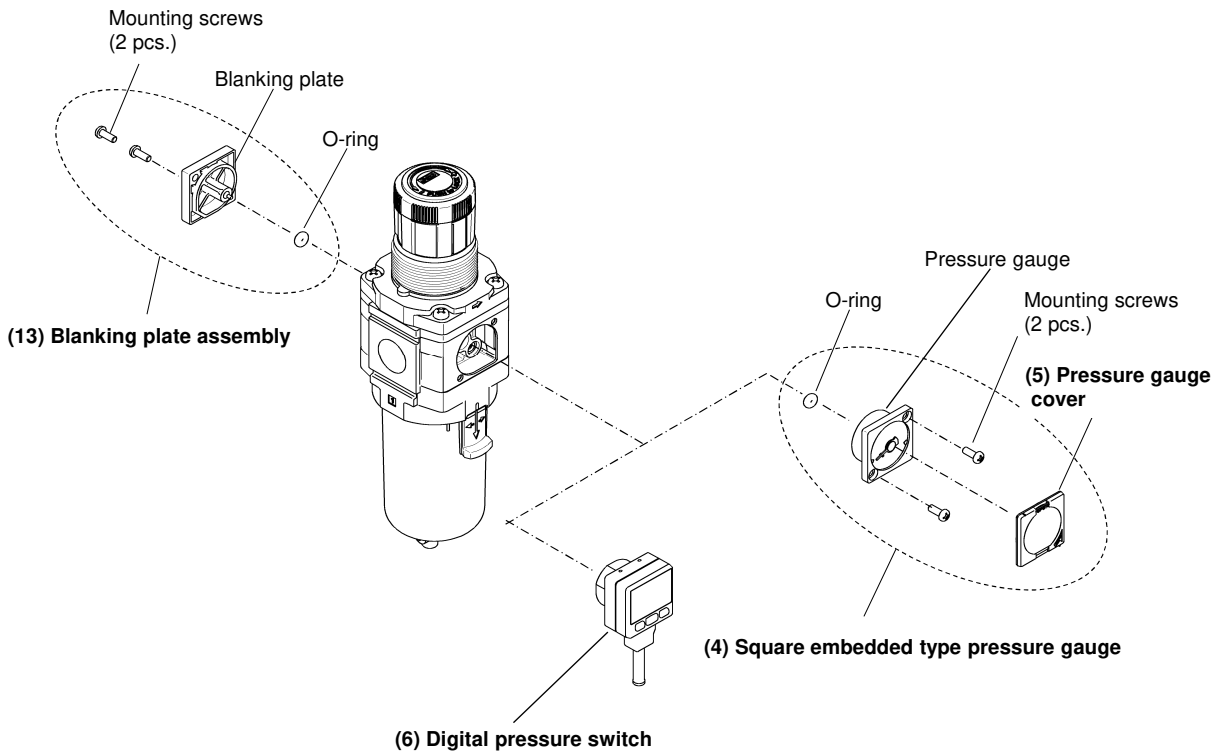

Note) Refer to the operation manual included in the product with digital pressure switch.

- When the pressure gauge or the digital pressure switch is mounted on the back of the product, swap all parts for the front and back.
- When swapping (4) Square embedded type pressure gauge and (6) Digital pressure switch, tighten them with $0.85 \pm 0.05 \text{ N} \cdot \text{m}$. Tighten others with $0.6 \pm 0.05 \text{ N} \cdot \text{m}$.

Note

There are two types of bodies, which are 12-2 and 12-3 described above according to the model. Please note that the applicable model cannot be changed by switching these two types of products.

Type	Applicable model	Model (Representative type)
12-2	Without pressure gauge/ With pressure gauge (round type)	AWD30-03-D / AWD30-03G-D
12-3	With square-type pressure gauge/ With digital pressure switch	AWD30-03E-D / AWD30-03E1-D

13. Dimensions

13-1. Standard (with round type pressure gauge)

Panel mounting dimensions

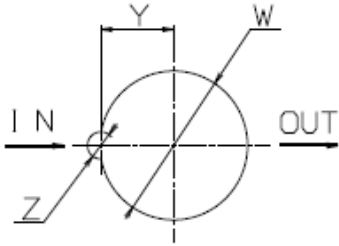
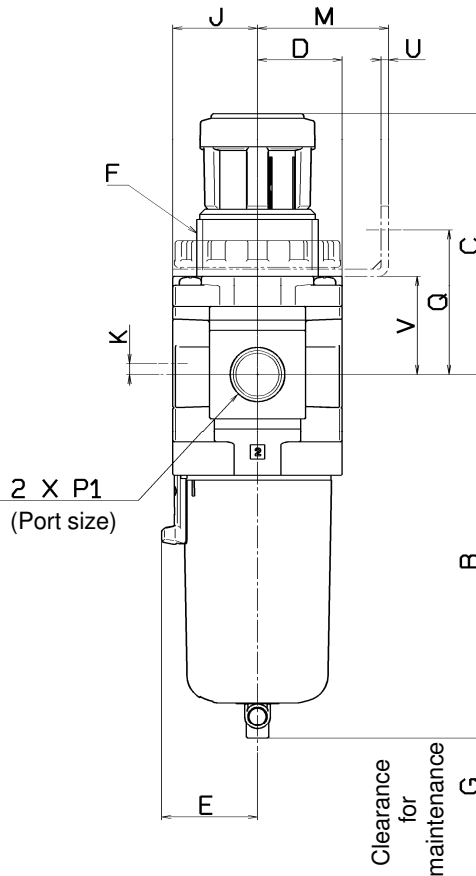
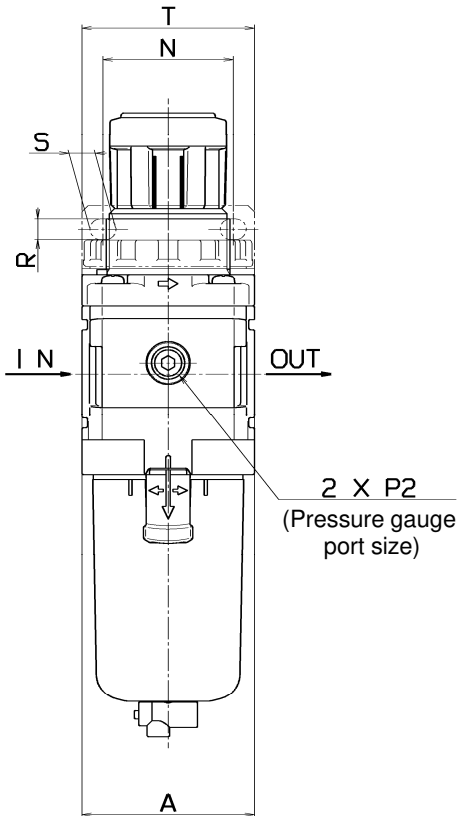
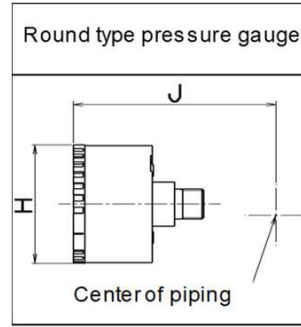

Plate thickness
 AWD20-D, AWD30-D : Max. 3.5
 AWD40-D : Max. 5



Dimensions

Model	Standard specifications											Optional specifications					
												Round type pressure gauge		Round type pressure gauge (Semi-standard: Z)		Round type pressure gauge (With color zone)	
	P ₁	P ₂	A	B	C	D	E	F	G	J	K	H	J	H	J	H	J
AWD20-D	1/8, 1/4	1/8	40	100.6	71.8	21	-	M28×1	45	21	5	φ37.5	57.5	φ37.5	58.5	φ37.5	58.5
AWD30-D	1/4, 3/8	1/8	53	115.4	86.5	26.5	30	M38×1.5	50	26.5	3.5	φ37.5	63	φ37.5	64	φ37.5	64
AWD40-D	1/4, 3/8, 1/2	1/8	70	147.1	91.5	35.5	38.4	M42×1.5	75	35.5	0	φ42.5	73	φ42.5	73	φ42.5	73

Model	Optional specifications												Semi-standard specifications						
	Bracket mount						Panel mount						With auto drain	PC/ PA bowl		Metal bowl		Metal bowl with level gauge	
	M	N	Q	R	S	T	U	V	W	Y	Z	B		With barb fitting	With drain guide	With drain cock	With drain guide	With drain cock	With drain guide
	M	N	Q	R	S	T	U	V	W	Y	Z	B	B	B	B	B	B	B	
AWD20-D	30	34	43.9	5.4	15.4	55	2.3	29.7	28.5	14	6	117.9	-	104.4	100.4	106.9	-	-	
AWD30-D	41	40	46	6.5	8	53	2.3	31.3	38.5	19	7	157.1	123.9	122.2	117.8	122.3	137.8	142.3	
AWD40-D	50	54	54	8.5	10.5	70	2.3	35.5	42.5	21	7	186.9	155.6	153.9	149.6	154.1	169.6	174.1	

The dimension C is the length when the filter regulator knob is unlocked.

13-2. Standard (with square embedded type pressure gauge or digital pressure switch)

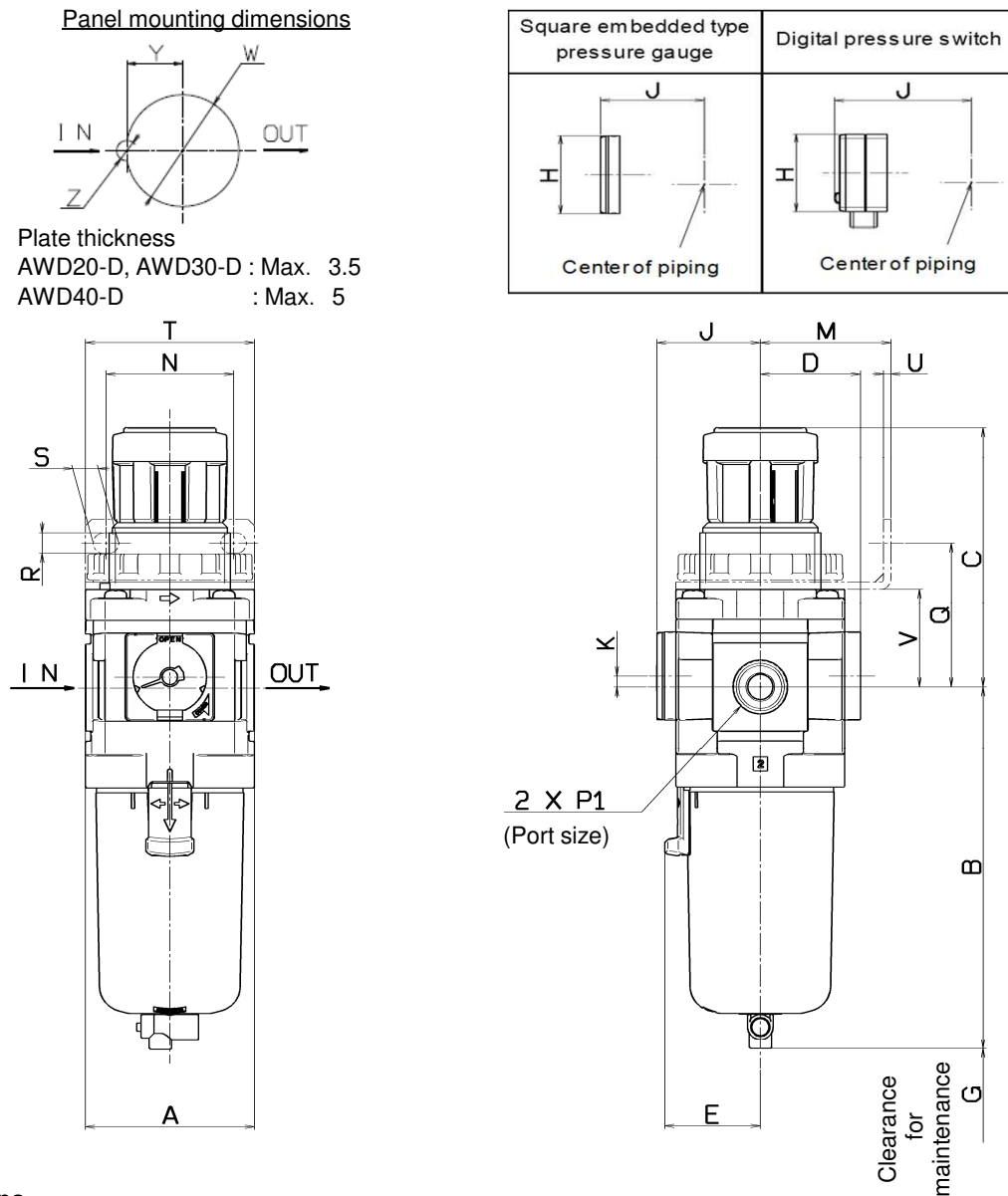

Dimensions

Model	Standard specifications									Optional specifications			
										Square embedded type pressure gauge		Digital pressure switch	
	P ₁	A	B	C	D	E	F	G	K	H	J	H	J
AWD20-D	1/8, 1/4	40	100.6	71.8	26	-	M28×1	45	5	□28	27	□27.8	37.5
AWD30-D	1/4, 3/8	53	115.4	86.5	31.5	30	M38×1.5	50	3.5	□28	32.5	□27.8	43
AWD40-D	1/4, 3/8, 1/2	70	147.1	91.5	40.5	38.4	M42×1.5	75	0	□28	41.5	□27.8	52

Model	Optional specifications											Semi-standard specifications						
	Bracket mount						Panel mount					With auto drain	PC/PA bowl		Metal bowl		Metal bowl with level gauge	
	M	N	Q	R	S	T	U	V	W	Y	Z		B	B	B	B	B	B
AWD20-D	30	34	43.9	5.4	15.4	55	2.3	29.7	28.5	14	6	117.9	-	104.4	100.4	106.9	-	-
AWD30-D	41	40	46	6.5	8	53	2.3	31.3	38.5	19	7	157.1	123.9	122.2	117.8	122.3	137.8	142.3
AWD40-D	50	54	54	8.5	10.5	70	2.3	35.5	42.5	21	7	186.9	155.6	153.9	149.6	154.1	169.6	174.1

The dimension C is the length when the filter regulator knob is unlocked.

Revision history

SMC Corporation

4-14-1, Sotokanda, Chiyoda-ku, Tokyo 101-0021 JAPAN

Tel: + 81 3 5207 8249 Fax: +81 3 5298 5362

URL <https://www.smcworld.com>