



Operation Manual

PRODUCT NAME

Air cylinder

MODEL / Series / Product Number

C * A2 * (F) 40 & 100 - * Z
C * A2 * 40 & 100 (TN/TF) - * Z
C * A2 * 40 & 100 - * Z - XC7
C * A2 * 40 & 100 - * Z - XC22
C * A2D40 & 100 - * Z - XC27
C * A2 * 40 & 100 - * Z - XC28
C * A2 * 40 & 100 - * Z - XC29
C * A2 * 40 & 100 - * Z - XC65
C * A2 * 40 & 100 - * Z - XC68
C * A2 * 40 & 100 - * Z - XC85

SMC Corporation

Contents

Safety Instructions	P2
1. Specifications	P4
1-1. Specifications	
2. Installation and Handling	P4
2-1. Air supply	
2-2. Design	
2-3. Mounting and Installation	
2-4. Environment	
2-5. Speed control	
2-6. Allowable kinetic energy	
2-7. Air cushion	
2-8. Control direction	
2-9-1. Mounting brackets	
2-9-2. Auto switches	
3. Maintenance	P25
3-1. Checks	
3-2. Replacement of seals	
3-3. Consumable parts	
3-4. Troubleshooting	
4. Made to order product (XC85)	P32
4-1. Food Machinery Grease Specification	
5. Basic Circuit for Cylinder Operation	P33
6. Construction	P34



Safety Instructions

These safety instructions are intended to prevent hazardous situations and/or equipment damage. These instructions indicate the level of potential hazard with the labels of "Caution," "Warning" or "Danger." They are all important notes for safety and must be followed in addition to International Standards (ISO/IEC)^{*1)}, and other safety regulations.

*1) ISO 4414: Pneumatic fluid power -- General rules relating to systems.

ISO 4413: Hydraulic fluid power -- General rules relating to systems.

IEC 60204-1: Safety of machinery -- Electrical equipment of machines .(Part 1: General requirements)

ISO 10218-1992: Manipulating industrial robots -Safety.

etc.



Caution

Caution indicates a hazard with a low level of risk which, if not avoided, could result in minor or moderate injury.



Warning

Warning indicates a hazard with a medium level of risk which, if not avoided, could result in death or serious injury.



Danger

Danger indicates a hazard with a high level of risk which, if not avoided, will result in death or serious injury.

Warning

1. The compatibility of the product is the responsibility of the person who designs the equipment or decides its specifications.

Since the product specified here is used under various operating conditions, its compatibility with specific equipment must be decided by the person who designs the equipment or decides its specifications based on necessary analysis and test results.

The expected performance and safety assurance of the equipment will be the responsibility of the person who has determined its compatibility with the product.

This person should also continuously review all specifications of the product referring to its latest catalog information, with a view to giving due consideration to any possibility of equipment failure when configuring the equipment.

2. Only personnel with appropriate training should operate machinery and equipment.

The product specified here may become unsafe if handled incorrectly.

The assembly, operation and maintenance of machines or equipment including our products must be performed by an operator who is appropriately trained and experienced.

3. Do not service or attempt to remove product and machinery/equipment until safety is confirmed.

1. The inspection and maintenance of machinery/equipment should only be performed after measures to prevent falling or runaway of the driven objects have been confirmed.

2. When the product is to be removed, confirm that the safety measures as mentioned above are implemented and the power from any appropriate source is cut, and read and understand the specific product precautions of all relevant products carefully.

3. Before machinery/equipment is restarted, take measures to prevent unexpected operation and malfunction.

4. Contact SMC beforehand and take special consideration of safety measures if the product is to be used in any of the following conditions.

1. Conditions and environments outside of the given specifications, or use outdoors or in a place exposed to direct sunlight.

2. Installation on equipment in conjunction with atomic energy, railways, air navigation, space, shipping, vehicles, military, medical treatment, combustion and recreation, or equipment in contact with food and beverages, emergency stop circuits, clutch and brake circuits in press applications, safety equipment or other applications unsuitable for the standard specifications described in the product catalog.

3. An application which could have negative effects on people, property, or animals requiring special safety analysis.

4. Use in an interlock circuit, which requires the provision of double interlock for possible failure by using a mechanical protective function, and periodical checks to confirm proper operation.



Safety Instructions

Caution

1. The product is provided for use in manufacturing industries.

The product herein described is basically provided for peaceful use in manufacturing industries.

If considering using the product in other industries, consult SMC beforehand and exchange specifications or a contract if necessary.

If anything is unclear, contact your nearest sales branch.

Limited warranty and Disclaimer/Compliance Requirements

The product used is subject to the following “Limited warranty and Disclaimer” and “Compliance Requirements”.

Read and accept them before using the product.

Limited warranty and Disclaimer

1. The warranty period of the product is 1 year in service or 1.5 years after the product is delivered, whichever is first.*2)

Also, the product may have specified durability, running distance or replacement parts. Please consult your nearest sales branch.

2. For any failure or damage reported within the warranty period which is clearly our responsibility, a replacement product or necessary parts will be provided.

This limited warranty applies only to our product independently, and not to any other damage incurred due to the failure of the product.

3. Prior to using SMC products, please read and understand the warranty terms and disclaimers noted in the specified catalog for the particular products.

***2) Vacuum pads are excluded from this 1 year warranty.**

A vacuum pad is a consumable part, so it is warranted for a year after it is delivered.

Also, even within the warranty period, the wear of a product due to the use of the vacuum pad or failure due to the deterioration of rubber material are not covered by the limited warranty.

Compliance Requirements

1. The use of SMC products with production equipment for the manufacture of weapons of mass destruction (WMD) or any other weapon is strictly prohibited.

2. The exports of SMC products or technology from one country to another are governed by the relevant security laws and regulations of the countries involved in the transaction. Prior to the shipment of a SMC product to another country, assure that all local rules governing that export are known and followed.

1. Specifications

1-1 Specifications

Fluid	Air
Proof pressure	1.5MPa
Max. operating pressure	1.0MPa
Min. operating pressure	0.05MPa
Ambient and fluid temperature	-10 to +70°C. -10 to +60°C with built-in magnet (No freezing)
Lubrication	Not required (non-lube)
Stroke length tolerance	to 250st $^{+1.0}_0$ mm 251 to 1000st $^{+1.4}_0$ mm 1001st to 1500st $^{+1.8}_0$ mm
Cushion	Air cushion
Pistonspeed	50 to 500mm/sec
Action	Double acting

Use the actuator with allowable kinetic energy or less.

{Refer to 2-6. Allowable kinetic energy (Page 9)}

Warning

- **Confirm the specifications.**

These product are designed only for use in compressed air systems (including vacuum). Do not operate at pressures or temperatures, etc., beyond the range of specifications, as this can cause damage or malfunction. (Refer to the specifications.)

Please contact SMC when using a fluid other than compressed air made by pneumatic equipment (including vacuum).

We do not guarantee against any damage if the product is used outside of the specification range.

- **Confirm the applicable specification range.**

These product specification apply to standard strokes, including intermediate strokes. Please consult with SMC for specifications on long strokes. There are also some made-to-order products (-XB□/-XC□) for which product specifications do not apply.

2. Installation and Handling

2-1. Air supply

The compressed air supplied to the cylinder should be filtered by SMC AF series air filter and regulated to the specified set pressure by SMC AR series regulator.

Warning

- **Type of fluids**

Please consult with SMC when using the product in applications other than compressed air.

- **When there is a large amount of drainage.**

Compressed air containing a large amount of drainage can cause malfunction of pneumatic equipment. An air dryer or water separator should be installed upstream from filters.

- **Drain flushing**

If condensation in the drain bowl is not emptied on a regular basis, the bowl will overflow and allow the condensation to enter the compressed air lines. It causes malfunction of pneumatic equipment.

If the drain bowl is difficult to check and remove, installation of a drain bowl with an auto drain option is recommended.

- **Use clean air.**

Do not use compressed air that contains chemicals, synthetic oils including organic solvents, salt or corrosive gases, etc, as it can cause damage or malfunction.

Caution

- **Install an air filter.**
Install an air filter upstream near the valve. Select an air filter with a filtration size of 5 µm or smaller.
- **Take measures to ensure air quality, such as by installing an aftercooler, air dryer, or water separator.**
Compressed air that contains a large amount of drainage can cause malfunction of pneumatic equipment such as valves.
Therefore, take appropriate measures to ensure air quality, such as by providing an aftercooler, air dryer, or water separator.
- **Ensure that the fluid and ambient temperature are within the specified range.**
When operating at temperatures below 5°C, water in the circuit may freeze and cause breakage of seals or malfunction. Corrective measures should be taken to prevent freezing.
- **Lubricating the non-lube type cylinder**
The cylinder has been lubricated for life at the factory and can be used without any further lubrication.
However, in the event that it is additionally lubricated, be sure to use class 1 turbine oil (with no additive) ISO VG32. Do not use machine oil or spindle oil.
Stopping lubrication later may lead to malfunction because the new lubricant will displace the original lubricant. Therefore, lubrication must be continued once it has been started.
If turbine oil is used, refer to the corresponding Material Safety Data Sheet (MSDS).

For compressed air quality, refer to Best Pneumatics No. 5.

2-2. Design

The compatibility of the product is the responsibility of the person who designs the equipment or decides its specifications.

Warning

- **There is a danger of sudden action by cylinders if sliding parts of machinery are twisted, etc., and changes in forces occur.**
In such cases, human injury may occur; e.g., by catching hands or feet in the machinery, or damage to the machinery itself may occur. Therefore, the machine should be designed to operate smoothly and to avoid such dangers.
- **If there is a chance that the product will pose a hazard to humans, install a protective cover.**
If the moving portion of the product will pose a hazard to humans or will damage machinery or equipment, provide a construction that prevents direct contact with those areas.
- **Be certain that the secured portions will not loosen.**
Be certain to adopt a reliable connecting method if the cylinder is used very frequently or if it is used in a location that is exposed to a large amount of vibration.
- **There may be cases in which a speed reduction circuit or a shock absorber is required.**
If the driven object moves at high speeds or is heavy, it will be unfeasible for only the cylinder's cushion to absorb the shock.
Therefore, provide a speed-reduction circuit to reduce the cylinder's speed before the thrust is applied to the cushion, or an external shock absorber to dampen the shock. If these countermeasures are taken, make sure to take the rigidity of the mechanical equipment into consideration.
- **Design the system so that it will not apply an external force over the maximum force to the product.**
The product can break, causing a risk of injury or damage to equipment.
- **The product generates a large force. Install on a sufficiently rigid mounting base, taking this force into consideration.**
There is a risk of injury or damage to equipment.

- **Consider the possibility of a reduction in the circuit air pressure caused by a power failure.**

When a cylinder is used in a clamping mechanism, the work piece may come off due to a decrease in clamping force because of a decrease in the circuit pressure caused by a power failure, etc. Therefore, safety equipment should be installed to prevent damage to machinery and injury. Suspension equipment and lifting devices also require measures to prevent dropping.

- **Consider the possibility of power source related malfunction that could occur.**

For the equipment that rely on power sources such as compressed air, electricity, or hydraulic pressure, adopt a countermeasure to prevent the equipment from causing a hazard to humans or damage to the equipment in the event of malfunction.



- **Consider the behavior of the cylinder in the event of an emergency stop.**

Devise a safe system so that if a person engages the emergency stop, or if a safety device is tripped during a system malfunction such as a power outage, the movement of the cylinder will not cause a hazard to humans or damage the equipment.

- **Avoid synchronized operation using cylinders only.**

Even if multiple pneumatic cylinders are initially set to the same speed, their speed may vary due to changes in operating conditions. Therefore, avoid designs where a single load is moved by synchronizing multiple cylinder operations.

- **Consider the action when operation is restarted after an emergency stop or abnormal stop.**

Design the machinery so that injury or equipment damage will not occur upon restart of operation. When the cylinder has to be reset at the starting position, install manual safety equipment.

- **Intermediate stop**

It is difficult for this product to make a piston stop at the required intermediate position accurately and precisely using a 3 position closed center type directional control valve, due to the compressibility of air. Furthermore, since valves and cylinders are not guaranteed for zero air leakage, it may not be possible to hold a stopped position for extended periods of time. Contact SMC if it is necessary to hold the stopped position for extended periods of time.



Caution

- **Avoid having a large gap between the clevis and mating bushing, as this exposes the pin to a bending load.**

- **Do not touch the cylinder during high speed and high frequency operation of the cylinder.**

When the cylinder is operating at a high speed and high frequency, the cylinder tube surface temperature increases, and may cause a burn.

- **Do not use the air cylinder as an air-hydro cylinder.**

If working fluid of the air cylinder is turbine oil, oil leakage can result.

- **Grease is applied to cylinder.**

- **The base oil of grease may seep out.**

The base oil of grease in the cylinder may seep out of the tube, cover, crimped part or rod bushing depending on the operating conditions (ambient temperature 40 °C or more, pressurized condition, low frequency operation). Please consult with SMC in cases where a particular clean environment is required.

2-3. Mounting and Installation

The foot mounting cylinder has a hole in the foot to drive a pin into for accurate positioning and fixing.



Caution

- **Do not apply excessive lateral load to the piston rod.**

The bold solid lines in Fig. 1 show the allowable lateral load on the cylinder for a certain stroke length.

Refer to Table 1 Maximum Allowable Kinetic Energy.(Page 9)

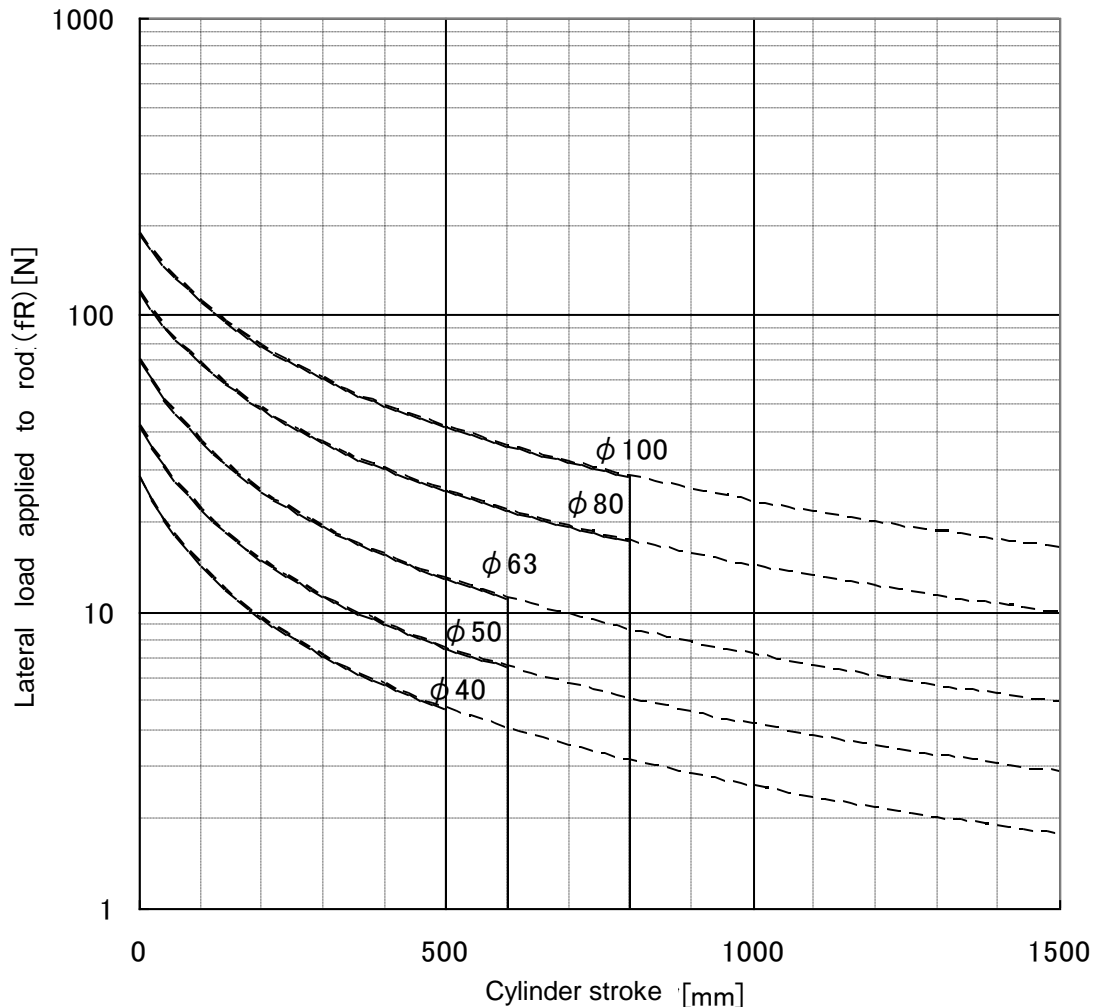
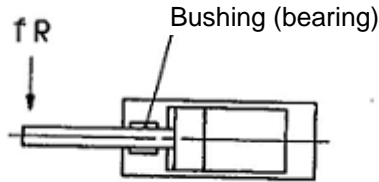

Fig. 1 Allowable lateral load applied to rod end

⚠ Caution

- ⦿ **Be certain to align the rod axis with the load and direction of movement when connecting.**
 When not properly aligned, the rod and tube may be twisted, and damage may be caused due to wear on areas such as the inner tube surface, bushings, rod surface and seals.
- ⦿ **When an external guide is used, connect the rod end and the load in such a way that there is no interference at any point within the stroke.**
- ⦿ **Do not scratch or gouge the sliding parts of the cylinder tube or piston rod, etc., by striking or grasping them with other objects.**
 Cylinder bores are manufactured to precise tolerances, so that even a slight deformation may cause malfunction. Also, scratches or gouges, etc., in the piston rod may lead to damaged seals and cause air leakage.
- ⦿ **Prevent the seizure of rotating parts.**
 Prevent the seizure of rotating parts (pins, etc.) by applying grease.
- ⦿ **Do not use until you can verify that equipment can operate properly.**
 Verify correct mounting by function and leak tests properly after compressed air and power are connected following mounting or repair.

- **Cantilever fastening**

If a cylinder is actuated at high speed when mounted with one side fastened and one side free (basic type, flange type, direct mount type), the bending moment may act on the cylinder due to vibration at the stroke end, causing damage to the cylinder. In such cases, install a mounting bracket to suppress vibration of the cylinder body, or reduce piston speed until the cylinder body does not vibrate at the stroke end. Also, use a mounting bracket when moving the cylinder body, or mounting a long stroke cylinder horizontally with one-sided fastening.

- **Do not apply excessive lateral load to the piston rod.**

Calculation for excessive lateral load:

Minimum operating pressure value after the device is mounted (MPa) = Cylinder's minimum operating pressure(MPa) + {Load weight(kg)

× Guide friction coefficient / Cylinder's cross section (mm²)}

If the product is found to operate smoothly with the calculated pressure, it has been determined that the alignment of the guides have not created additional loading on the cylinder.

- **Do not let foreign matter such as cutting chips get into the product from the supply port.**

When the product is installed on a machine on site, the debris from drilled mounting holes can get in the supply port of the product. Take sufficient care to prevent this.

2-4. Environment

Warning

- **Do not use in an atmosphere having corrosive gases, chemicals, sea water, water, water steam, or where there is direct contact with any of these.**
- **Do not expose the product to direct sunlight for an extended period of time.**
- **Do not use in a place subject to heavy vibration and/or shock.**
- **Do not mount the product in locations where it is exposed to radiant heat.**
- **Do not use in dusty locations or where water or oil, etc., splash on the equipment.**
- **When using auto switches, do not operate in an environment with strong magnetic fields.**
- **A decrease in grease base oil may be accelerated by the properties of compressed air used in pneumatic equipment, the external environment, or operating conditions, etc., and the resulting drop in lubricating performance may have an effect on equipment service life.**
- **Avoid storing the product in humid conditions.**

Store the product with the piston rod retracted and avoid humidity, in order to prevent generation of rust.

Caution

- Machined part of the piston rod and tie rod are not plated. If the generation of rust during usage or storage is not acceptable, please consult SMC.
- **Preparation before piping**
Before piping, perform air blow (flushing) or cleaning to remove any cutting chips, cutting oil, dust, etc. from the piping and fitting.
- **Wrapping of pipe tape**
When screwing piping or fittings into ports, ensure that chips from the pipe threads or sealing material do not enter the piping.
Also, if pipe tape is used, leave 1.5 to 2 thread ridges exposed at the end of the threads.

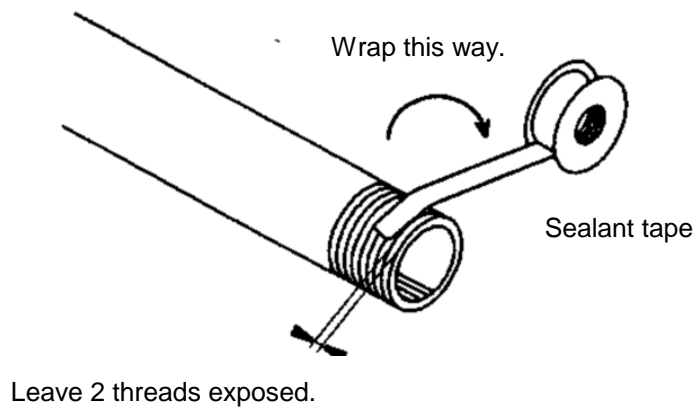

Fig. 2 Sealant tape

2-5. Speed control

- 1) When the cylinder speed is adjusted, install SMC AS Series Speed controllers around the air supply to adjust to the specified speed.
- 2) When speed controllers are used for adjusting speed, there are two cases, one is regulating the supply air to the cylinder (meter-in control), and another is regulating the exhaust air from the cylinder (meter-out control). In the former case, cylinder operation will be unstable. Generally, the latter case is applied.

Caution

- **Piston speed should be controlled gradually from low speed to the specified speed with a speed controller fully closed.**

2-6. Allowable kinetic energy

Warning

- **Use the actuator with allowable kinetic energy (Table 1) or less.**
Operation with a kinetic energy over the allowable value can break the product and cause injury or damage to equipment. If excessive kinetic energy is expected, install an external absorber to prevent impact to the body of the product. In this case, please verify the rigidity of the equipment carefully.

		$\phi 40$	$\phi 50$	$\phi 63$	$\phi 80$	$\phi 100$
Allowable kinetic energy (J)	Air cushion	2.8	4.6	7.8	16	29
	Non cushion	0.33	0.56	0.91	1.50	2.68

2-7. Cushion

Caution

- Cylinder cushions are adjusted properly at the time of shipment. However, readjust the cushion valve on the cover when the cylinder is put into service based upon working load and operating speed.
- When the cushion valve is turned clockwise, the cushion contracts and its effectiveness is increased, and when the cushion valve is turned counterclockwise, the cushion expands and its effectiveness is decreased.
- If the cushion valve is fully closed throughout operation, the piston may bounce at the stroke end, not move full stroke, or the cushion seal may be damaged due to excessive pressure. Therefore, do not use the cushion cover in such manner.
- Check that the screw of the cushion valve is screwed in. Although the snap ring is attached, the cushion valve may lurch if the screw is not fitted properly.
- Activate the air cushion when operating the cylinder. If this is not done, the piston rod assembly or the tie-rods will be damaged when the allowable kinetic energy exceeds the values shown in the table 1(P9).

Warning

- **Do not open the cushion valve beyond the stopper.**

A snap ring is installed as a cushion valve retention mechanism. Do not open the cushion valve beyond it. If not operated in accordance with the above precautions, the cushion valve may be ejected from the cover when air pressure is supplied.

Bore size (mm)	With across flats	Hexagon wrench
40,50,63	3	JIS 4648 Hexagon wrench key 3
80,100	4	JIS 4648 Hexagon wrench key 4

- **Use the air cushion at the end of cylinder stroke.**
Otherwise, the tie-rod or piston rod assembly will be damaged.

2-8. Control of direction

To switch the operating direction of the cylinder, mount an applicable solenoid valve selected from SMC's range of solenoid valves.

Warning

- **Design a circuit to prevent sudden action of a driven object.**

When the product is actuated by an exhaust center type directional control valve or when one side of the piston is pressurized with air exhaust, such as when the product is started after the exhaust of the residual pressure from the circuit, driven objects may act suddenly at high speed. In such cases, injury may occur, such as hands or feet getting caught in the machinery, or damage to the machinery itself may occur. Design the machinery to avoid such dangers.

2-9-1. Mounting bracket

- Mounting nut should be tightened while keeping all the tension equal.
- When they are tightened, please use proper tightening torque.
{(Refer to Table 10 (P29))}
- Before mounting a support bracket, make sure the product is aligned by placing on the leveled surface.
It is recommended to secure the mounting screws temporarily to insure alignment before tightening with the specified torque.

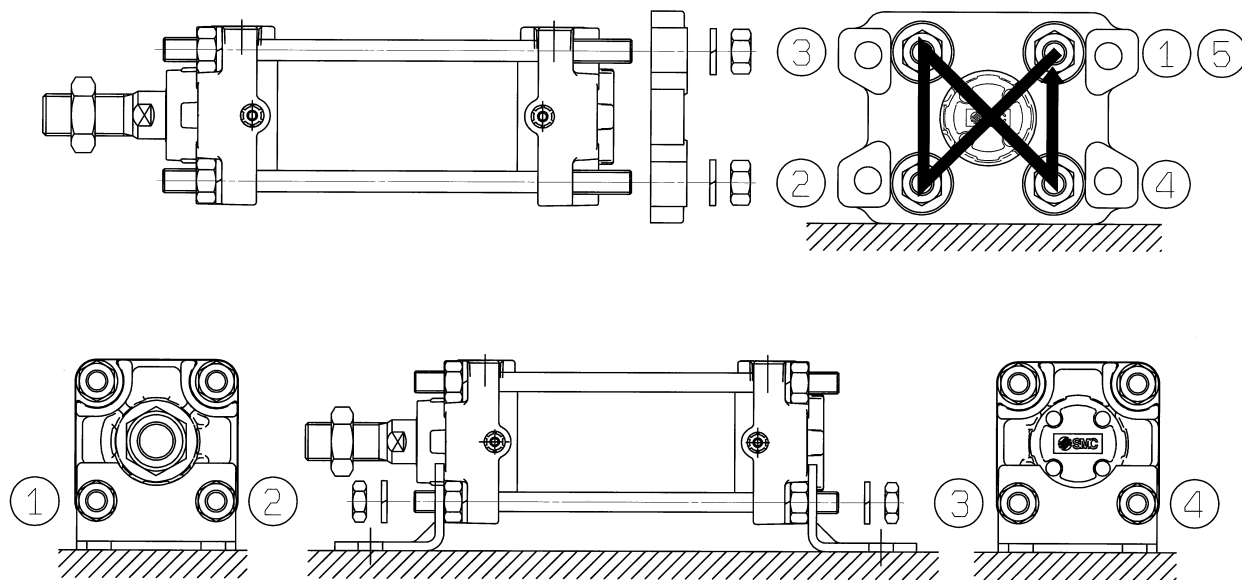

Fig 3. Order for tightening mounting screws

2-9-2. Auto switches

When an auto switch is mounted or its set position is changed, refer to Fig. 4 to 11.

Caution

- Use a specific mounting bracket (Page 19, Table 2) .
- Tighten mounting screws to the appropriate torque.
- The auto switch can only be used for cylinders with a built-in magnet for auto switch (e.g. CDA).
- The mounting of the switch is limited depending on stroke.

(See page 22 to 23, Table 5,6.)

< Applicable Auto switches >

Solid state auto switch D-M9N(V)·M9P(V)·M9B(V)
D-M9NW(V)·M9PW(V)·M9BW(V)
D-M9NA(V)·M9PA(V)·M9BA(V)

Reed auto switch D-A90(V)·A93(V)·A96(V)

Figure 4. How to Mount and Move the Auto Switch

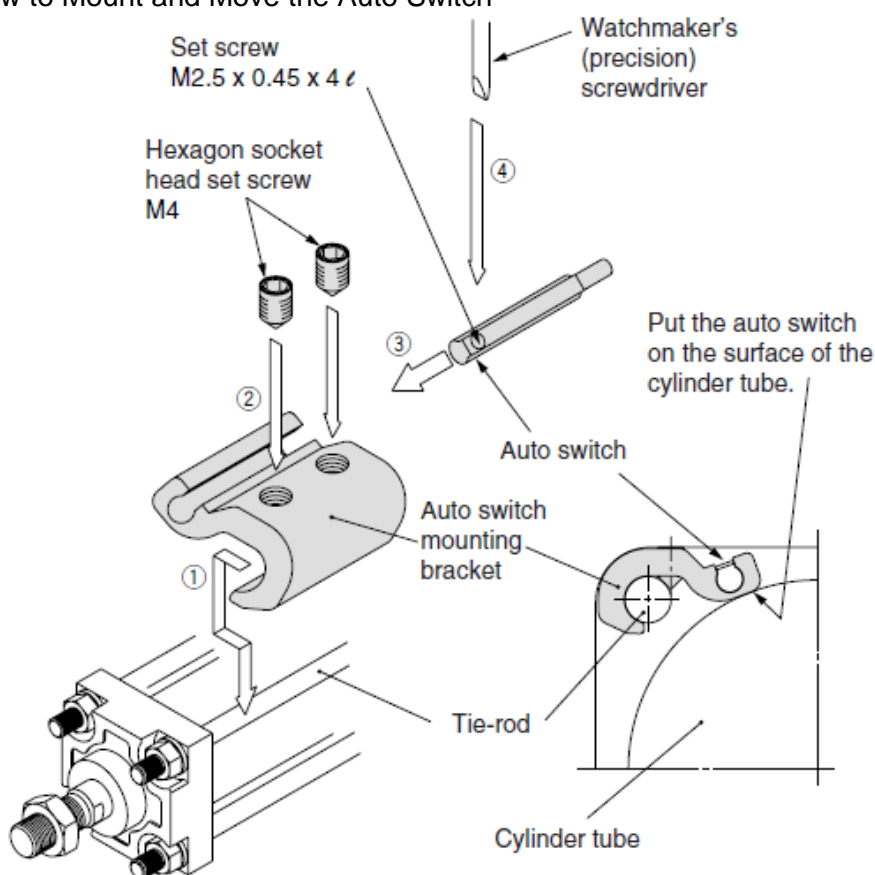

- (1) Fix it to the detecting position with a set screw by installing an auto switch mounting bracket in cylinder tie-rod and letting the bottom surface of an auto switch mounting bracket contact the cylinder tube firmly.
- (2) Fix it to the detecting position with a set screw (M4). (Use a hexagon wrench.)
- (3) Fit an auto switch into the auto switch mounting groove to set it roughly to the mounting position for an auto switch.
- (4) After confirming the detecting position, tighten up the mounting screw (M2.5) attached to an auto switch, and secure the auto switch.
- (5) When changing the detecting position, carry out in the state of 3.

Note 1) To protect auto switches, ensure that main body of an auto switch should be embedded into auto switch mounting groove with a depth of 15 mm or more.

Note 2) Set the tightening torque of a hexagon socket head set screw (M4) to be 1 to 1.2 N·m.

Note 3) When tightening an auto switch mounting screw (M2.5), use a watchmaker's screwdriver with a grip diameter of 5 to 6 mm. Also, set the tightening torque to be 0.05 to 0.15 N·m. As a guide, turn 90° from the position where it comes to feel tight.

< Applicable Auto switches >

Solid state auto switch D-F59•F5P

D-J59•J51•F5BAL

D-F59W•F59PW•J59W

Reed auto switch D-A53•A54•A56•A64•A67

D-A59W

Fig. 5 Mounting and movement of the auto switch

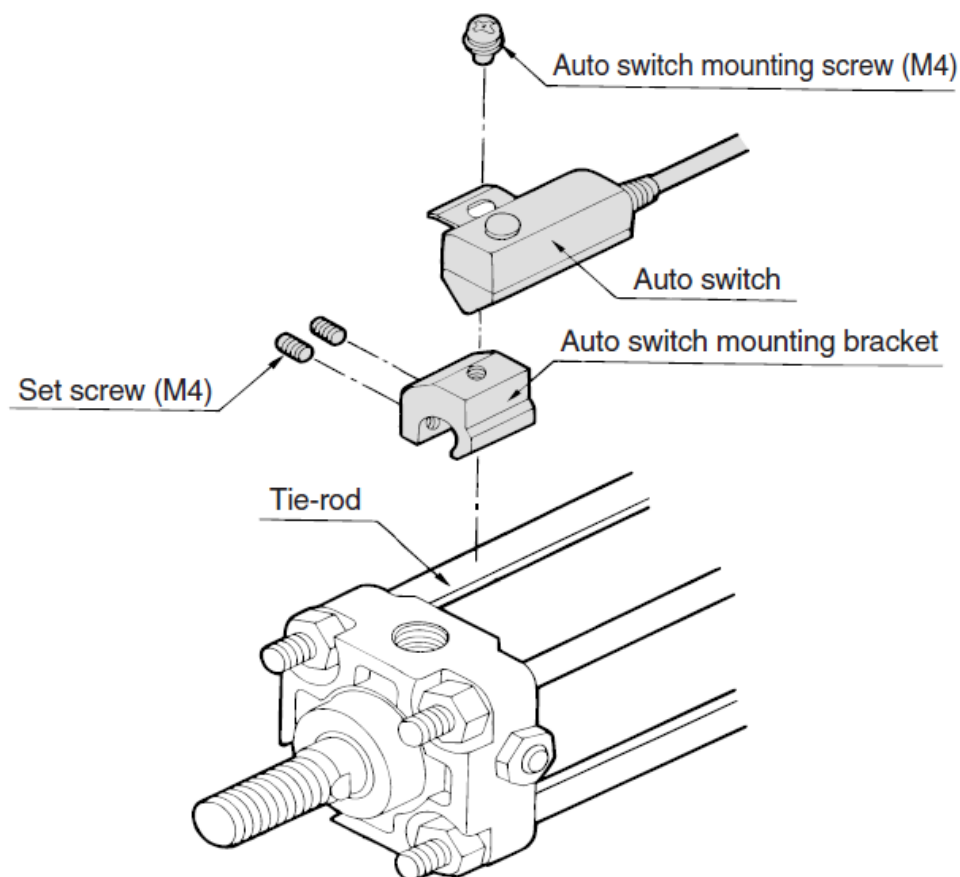

- (1) Fix the auto switch on the auto switch mounting bracket with the auto switch mounting screw (M4) and install the set screw.
- (2) Fit the auto switch mounting bracket into the cylinder tie-rod and then fix the auto switch at the detecting position with the hexagonal wrench.
(Be sure to put the auto switch on the surface of cylinder tube.)
- (3) When changing the detecting position, loosen the set screw to move the auto switch and then re-fix the auto switch on the cylinder tube.
(Tightening torque of M4 screw should be 1 to 1.2 N·m.)

< Applicable Auto switches >
Solid state auto switch D-G39C·K39C
Reed auto switch D-A33C·A34C·A44C

Fig. 6 Mounting and movement of the auto switch

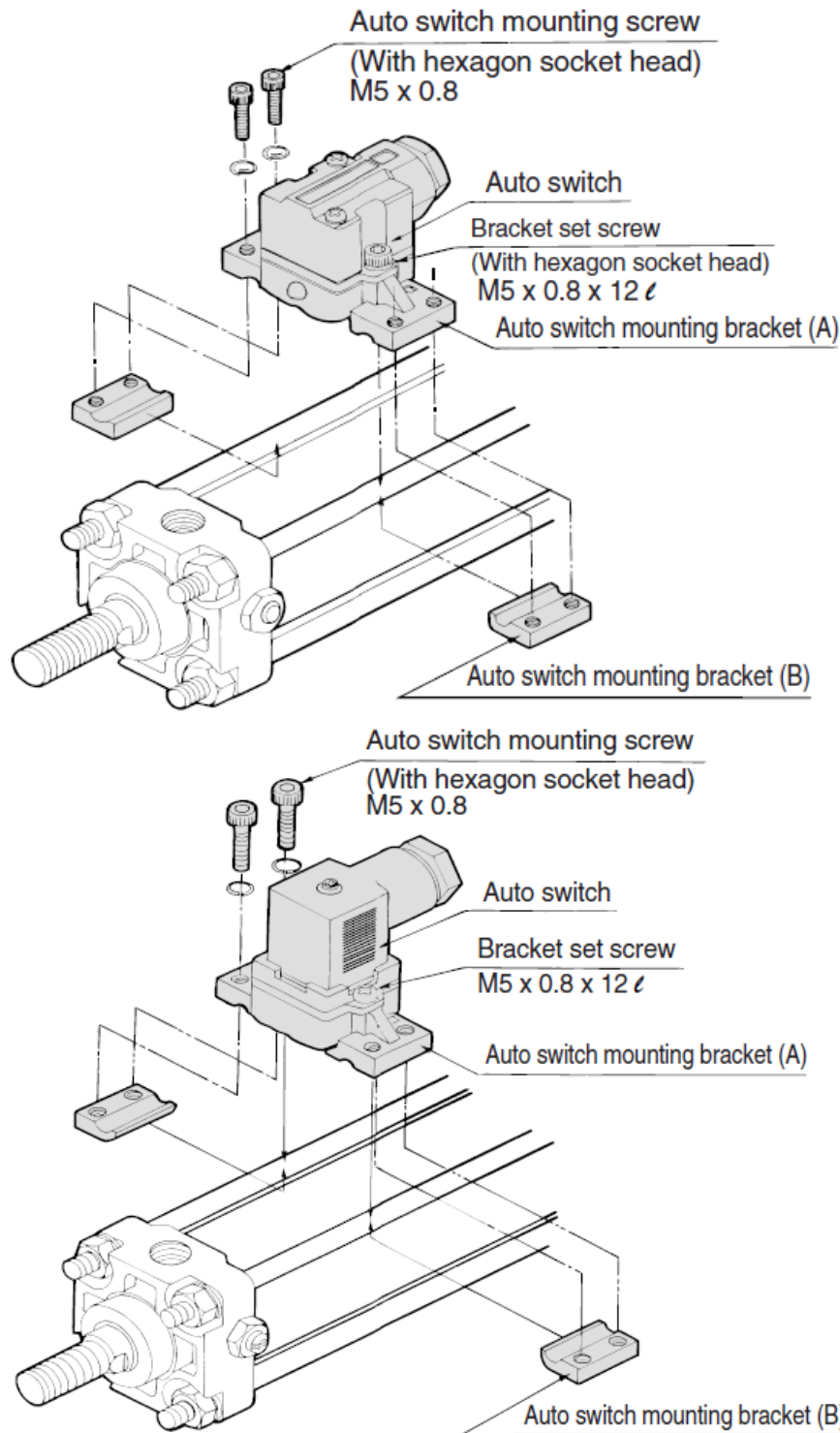

- (1) Fix the auto switch mounting bracket (A) on the auto switch with the set screw.
- (2) Fit the concave part of auto switch mounting bracket into tie-rod and set the auto switch at the mounting position.
- (3) Insert the auto switch mounting bracket (B) from the underneath and put lightly in the tie-rod with the mounting screw.
- (4) Set the whole body to the detecting position by sliding, tighten the mounting screw to secure the auto switch. (Tightening torque of M5 screw should be 2 to 3 N·m.)
- (5) Modification of the detecting position should be made in the condition of 3.

< Applicable Auto switches >

Solid state auto switch D-Y59A/B·Y69A/B·Y7P(V)
D-Y7NW(V)·Y7PW(V)·Y7BW(V)
D-Y7BAL
Reed auto switch D-Z73·Z76·Z80

Fig. 7 Mounting and movement of the auto switch

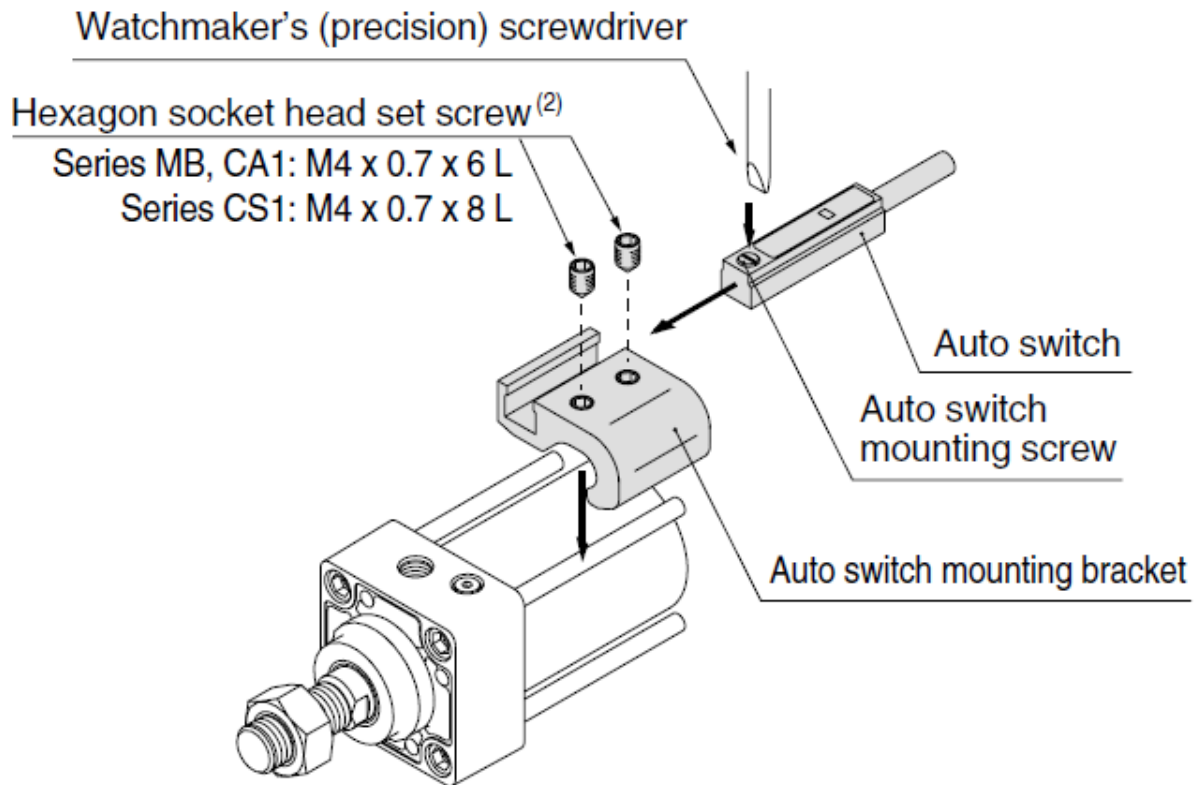

- (1) Fix it to the detecting position with a set screw by installing an auto switch mounting bracket in cylinder tie-rod and letting the bottom surface of an auto switch mounting bracket contact the cylinder tube firmly. (Use hexagon wrench)
- (2) Fit an auto switch into the auto switch mounting groove to set it roughly to the auto switch mounting position for an auto switch.
- (3) After confirming the detecting position, tighten up the mounting screw attached to an auto switch, and secure the switch.
- (4) When changing the detecting position, carry out in the state of 2.

Note 1) To protect auto switches, ensure that main body of an auto switch should be embedded into auto switch mounting groove with a depth of 15 mm or more.

Note 2) When tightening an auto switch mounting screw, use a watchmaker's screwdriver with a grip diameter of 5 to 6 mm. Also, set the tightening torque to be 0.05 to 0.1 N·m. As a guide, turn 90° from the position where it comes to feel tight. Set the tightening torque of a hexagon socket head set screw (M4 x 0.7) to be 1 to 1.2 N·m.

< Applicable Auto switches >
Solid state auto switch D-P3DW□

Fig. 8 Mounting and movement of the auto switch

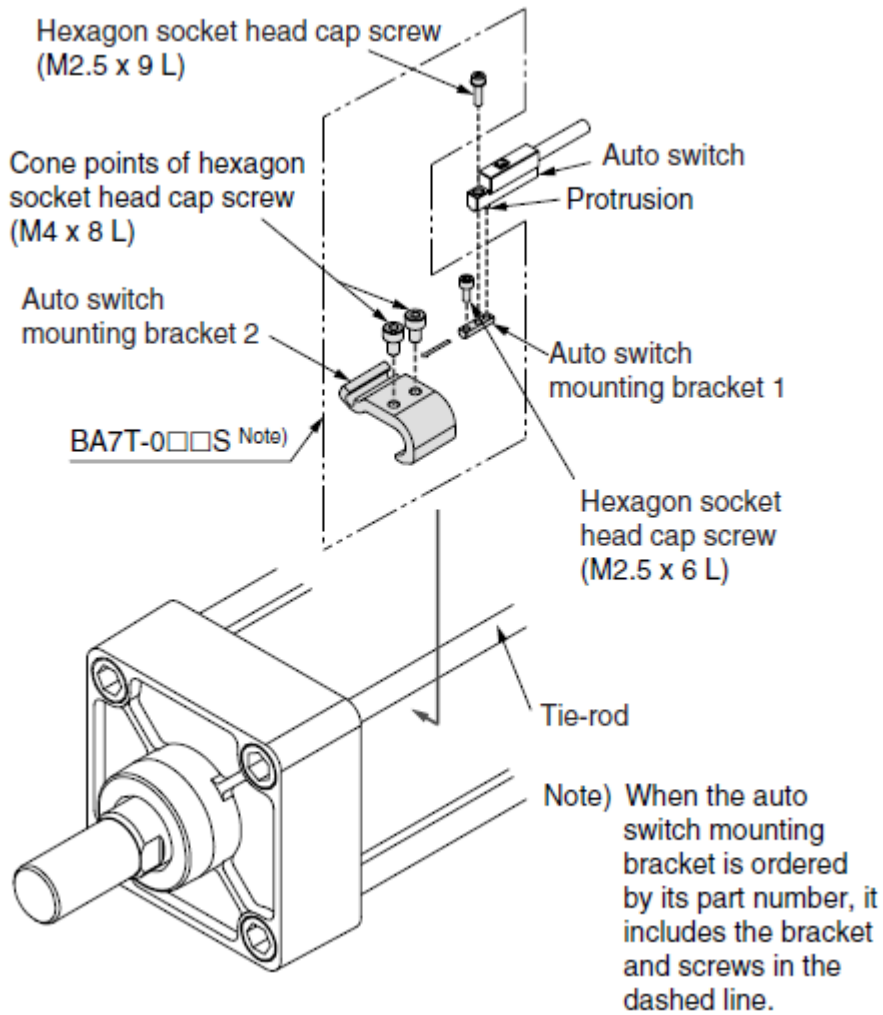

- (1) Install the auto switch mounting bracket 2 to the tie-rod, and fix it to the approximate mounting position with the cone points of hexagon socket head cap screw (M4 x 8 L) while keeping firm contact between the bottom of the auto switch mounting bracket 2 and the cylinder tube.
- (2) Insert the protrusion on the bottom of the auto switch into the mating part of the auto switch mounting bracket 1 and fix the auto switch and the auto switch mounting bracket 1 temporarily by tightening the hexagon socket head cap screw (M2.5 x 9 L) 1 to 2 turns.
- (3) Insert the temporarily tightened mounting bracket 1 to the mating groove of the mounting bracket 2, and fix the auto switch by tightening the hexagon socket head cap screw (M2.5 x 6 L and M2.5 x 9 L) after checking the detecting position.
- (4) If the detecting position is changed, go back to step 1 or 3.

Note 1) Ensure that the auto switch is covered with the mating groove by a minimum of 15 mm to protect the auto switch.

Note 2) When tightening the cone points of hexagon socket head cap screw (M4 x 8 L), keep the tightening torque within 1 to 1.2 N·m.

Note 3) The torque for tightening the hexagon socket head cap screw (M2.5 x 6 L, M2.5 x 9 L) is 0.2 to 0.3 N·m.

Note 4) Tighten the hexagon socket head cap screws evenly.

< Applicable Auto switches >
 Solid state auto switch D-P4DW□

Fig. 9 Mounting and movement of the auto switch

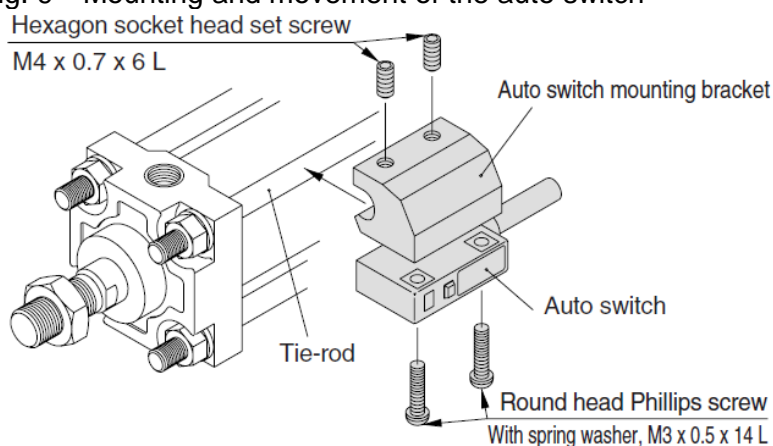

- (1) Slightly screw the hexagon socket head cap screw (M4 x 0.7 x 6 l) into the M4 tapped portion of auto switch mounting bracket. (2 locations) Use caution that the tip of the hexagon socket head set screw should not stick out to the concave portion of auto switch mounting bracket.
- (2) Put a hexagon socket head cap screw (with spring washer M3 x 0.5 x 14l) through the auto switch's through-hole (2 locations), and then push it down into the M3 tapped part on the auto switch mounting bracket while turning it lightly.
- (3) Place the concave part of the auto switch mounting bracket into the cylinder tie-rod, and slide the auto switch mounting bracket in order to set roughly to the detecting position.
- (4) After reconfirming the detecting position, tighten the M3 mounting screw to secure the auto switch by making the bottom face of auto switch attached to the cylinder tube. (Tightening torque of M3 screw should be 0.5 to 0.7 N·m.)
- (5) Tighten up M4 screw of auto switch mounting bracket to secure the auto switch mounting bracket. (Ensure that tightening torque of M4 screw should be set 1.0 to 1.2 N·m.)

< Applicable Auto switches >
 Solid state auto switch D-G59·G5P·K59·G5BAL
 D-G59W·G5PW·K59W
 D-G59F·G5NTL·G5NBL
 Reed auto switch D-B53·B54·B64·B59W

Fig. 10 Mounting and movement of the auto switch

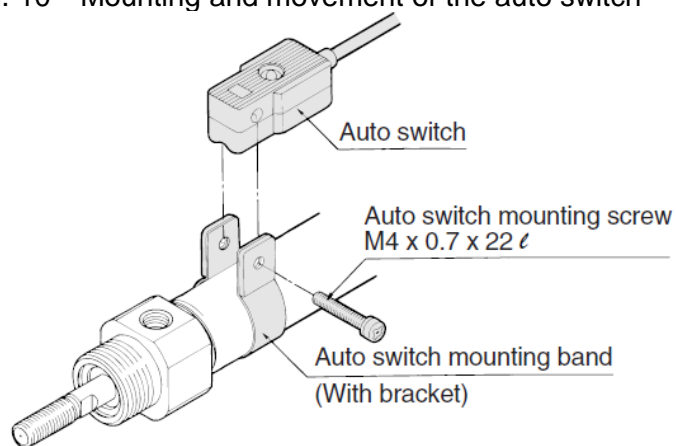

- (1) Put a mounting band on the cylinder tube and set it at the auto switch mounting position.
- (2) Put the mounting band section of the auto switch between the band mounting holes, then adjust the position of mounting holes of switch to those of mounting band.
- (3) Lightly thread the auto switch mounting screw through the mounting hole into the thread part of band fitting.
- (4) After reconfirming the detection position, tighten the mounting screw to secure the auto switch while properly contacting the auto switch bottom part and the cylinder tube. (The tightening torque of M4 screw should be about 1 to 1.2 N·m.)
- (5) Modification of the detection position should be made in the condition of 3.

< Applicable Auto switches >

Solid state auto switch D-G39·K39

Reed auto switch D-A33·A34·A44

Fig. 11 Mounting and movement of the auto switch

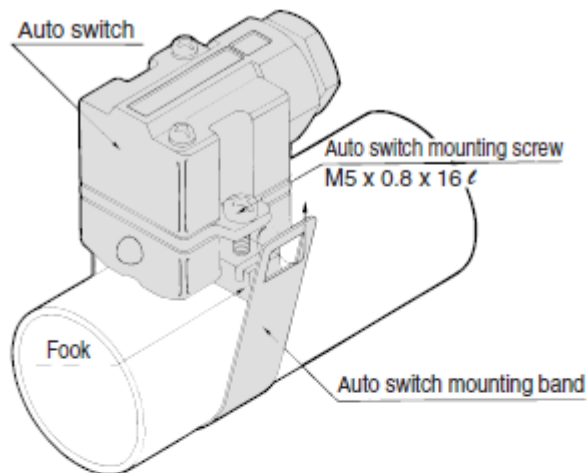

D-A44

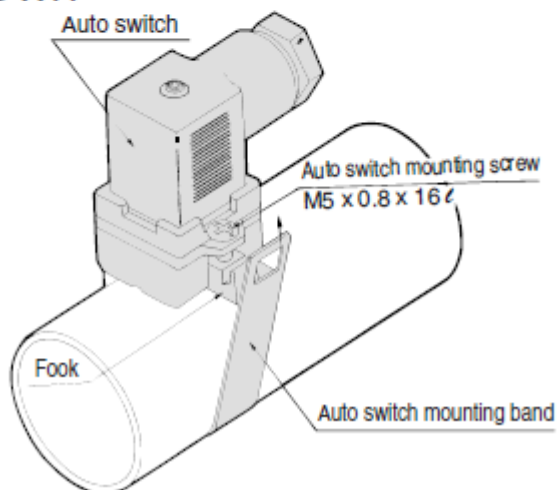

- (1) Loosen the auto switch mounting screws at both sides to pull down the hook.
- (2) Put an auto switch mounting band on the cylinder tube and set it at the auto switch mounting position, and then hook the band.
- (3) Screw lightly the auto switch mounting screw.
- (4) Set the whole body to the detecting position by sliding, tighten the mounting screw to secure the auto switch. (The tightening torque should be about 2 to 3 N·m.)
- (5) Modification of the detecting position should be made in the condition of 3.

Table 2 **Auto Switch Mounting Brackets/Part No.**

<Tie-rod mounting>

Auto switch model	Bore size (mm)				
	40	50	63	80	100
D-A9□/A9□V D-M9□/M9□V D-M9□W/M9□WV D-M9□A/M9□AV	BA7-040	BA7-040	BA7-063	BA7-080	BA7-080
D-A5□/A6□ D-A59W D-F5□/J5□ D-F5□W/J59W D-F59F/F5NT	BT-04	BT-04	BT-06	BT-08	BT-08
D-A3□C/A44C D-G39C/K39C	BA3-040	BA3-050	BA3-063	BA3-080	BA3-100
D-Z7□/Z80 D-Y59□/Y69□ D-Y7P/Y7PV D-Y7□W/Y7□WV D-Y7BA	BA4-040	BA4-040	BA4-063	BA4-080	BA4-080
D-P3DW	BMB9-050S	BMB9-050S	BA9T-063S	BA9T-080S	BA9T-080S
D-P4DW	BAP2-040	BAP2-040	BAP2-063	BAP2-080	BAP2-080

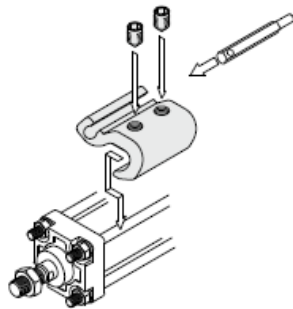

* The figure shows the mounting example for the D-A9□(V)/M9□(V)/M9□W(V)/M9□A(V)L types.

<Band mounting>

Auto switch model	Bore size (mm)				
	40	50	63	80	100
D-A3□/A44 D-G39/K39	BDS-04M	BDS-05M	BMB1-063	BMB1-080	BMB1-100
D-B5□/B64 D-B59W D-G5□/K59 D-G5□W/K59W D-G59F D-G5NT D-G5NB	BH2-040	BA5-050	BAF-06	BAF-08	BAF-10

Note 1) Auto switch brackets are included in the D-A3□C/A44C/G39C/K39C types. Specify the part number as follows depending on the cylinder size when ordering.
(Example) ø40: D-A3□C-4, ø50: D-A3□C-5, ø63: D-A3□C-6, ø80: D-A3□C-8, ø100: D-A3□C-10

[Stainless Steel Mounting Screw]

The following stainless steel mounting screw kit (including set screws) is also available. Use it in accordance with the operating environment.
(Since the auto switch mounting bracket is not included, order it separately.)

- BBA1: For D-A5/A6/F5/J5 types
- BBA3: For D-B5/B6/G5/K5 types

Note 2) Refer to pages 1357 and 1365 in Best Pneumatics No. 2 for details on the BBA1 and BBA3.

The above stainless steel screws are used when a cylinder is shipped with D-F5BA or G5BA auto switches. When only an auto switch is shipped independently, the BBA1 or BBA3 is attached.

Note 3) When using the D-M9□A(V) or Y7BA, do not use the steel set screws which are included with the auto switch mounting brackets above (BA7-□□□, BA4-□□□). Order a stainless steel screw kit (BBA1) separately, and use the M4 x 6L stainless steel set screws included in the BBA1.

Note 4) There is a difference in the cylinder tube thickness depending on the cylinder model. When a band mounting type is used as an applicable auto switch and a cylinder model is changed, use caution.

Table 3 **Operating Range**

Auto switch model	Bore size (mm)				
	40	50	63	80	100
D-A9□/A9□V	7.5	8.5	9.5	9.5	10.5
D-M9□/M9□V D-M9□W/M9□WV D-M9□A/M9□AV	4.5	5	5.5	5	6
D-Z7□/Z80	8.5	7.5	9.5	9.5	10.5
D-A3□/A44 D-A3□C/A44C	9	10	11	11	11
D-A5□/A6□					
D-B5□/B64					
D-A59W	13	13	14	14	15
D-B59W	14	14	17	16	18

Auto switch model	Bore size (mm)				
	40	50	63	80	100
D-Y59□/Y69□ D-Y7P/Y7□V D-Y7□W/Y7□WV D-Y7BA	8	7	5.5	6.5	6.5
D-F5□/J5□/F5□W D-J59W/F5BA D-F5NT/F59F	4	4	4.5	4.5	4.5
D-G5□/K59/G5□W D-K59W/G5BA D-G5NT/G59F	5	6	6.5	6.5	7
D-G5NBL	35	35	40	40	40
D-G39/K39 D-G39C/K39C	9	9	10	10	11
D-P3DW	4.5	5	6	5.5	6
D-P4DW	4	4	4.5	4	4.5

* Values which include hysteresis are for guideline purposes only, they are not a guarantee (assuming approximately ±30% dispersion) and may change substantially depending on the ambient environment.

Auto Switch Proper Mounting Position (Detection at stroke end) and Its Mounting Height

<Band mounting>

D-B5□/B64/B59W

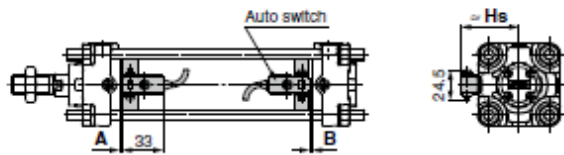

D-A3□
D-G39/K39

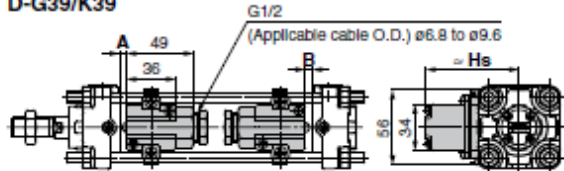

D-G5□/K59 D-G5BAL
D-G5□W/K59W D-G59F/G5NTL

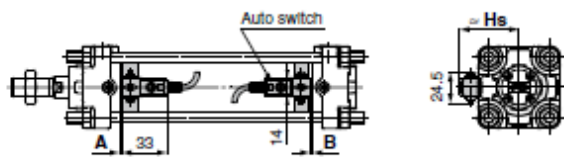

D-A44

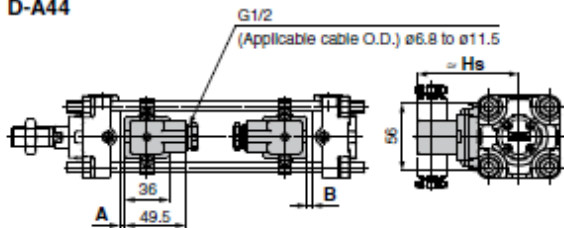

<Tie-rod mounting>

D-A9□/A9□V D-Z7□/Z80
D-M9□/M9□V D-Y59□/Y69□/Y7P□/Y7PV
D-M9□W/M9□WV D-Y7□W/Y7□WV
D-M9□A/M9□AV D-Y7BA

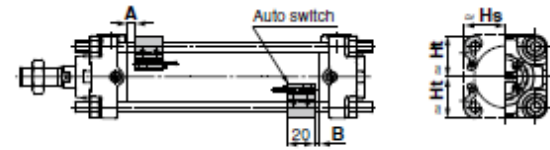

D-A5□/A6□
D-A59W

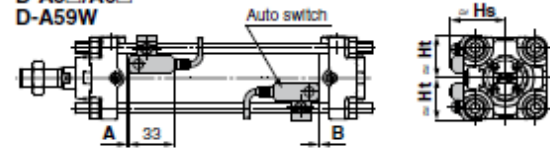

D-A3□C
D-G39C/K39C

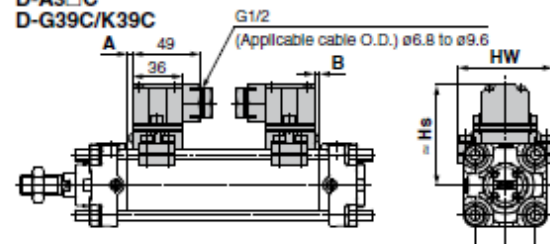

D-F5□/J5□ D-F5□W/J59W
D-F5NT D-F5BA/F59F

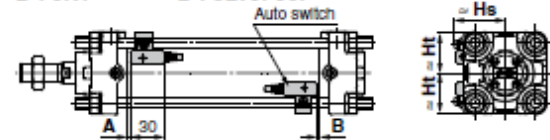

D-A44C

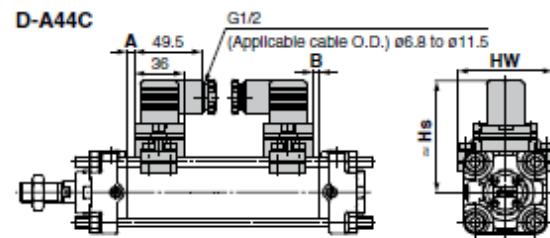

D-P3DW

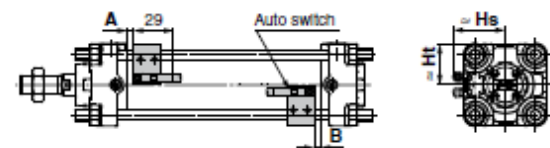

D-P4DW

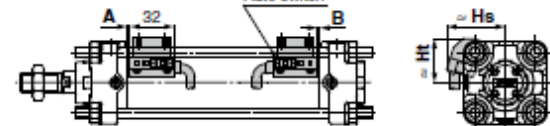

Table 4

Auto Switch Proper Mounting Position (Detection at stroke end) and Its Mounting Height

Auto Switch Proper Mounting Position

(mm)

Auto switch model	D-M9□ D-M9□V D-M9□W D-M9□WV D-M9□A D-M9□AV		D-A9□ D-A9□V D-J51		D-Y59□ D-Y69□ D-Y7P D-Y7PV D-Y7□W D-Y7□WV D-Y7BA D-Z7□ D-Z80 D-B59W		D-P3DW		D-P4DW		D-F5□ D-J59 D-F59F D-F5□W D-J59W D-F5BA		D-A59W		D-F5NT		D-G39 D-G39C D-K39 D-K39C D-A5□ D-A6□ D-A3□ D-A3□C D-A44 D-A44C		D-G5□ D-K59 D-G5NT D-G5□W D-K59W D-G5BA D-G59F		D-B5□ D-B64		
	A	B	A	B	A	B	A	B	A	B	A	B	A	B	A	B	A	B	A	B	A	B	A
40	9	9	5	5	2.5	2.5	4.5	4.5	2	2	5.5	5.5	3	3	10.5	10.5	0	0	1	1	0	0	
50	9.5	8.5	5.5	4.5	3	2	5	4	2.5	1.5	6	5	3.5	2.5	11	10	0	0	1.5	0.5	0	0	
63	12.5	11.5	8.5	7.5	6	5	3	2.5	5.5	4.5	9	8	6.5	5.5	14	13	2.5	1.5	4.5	3.5	3	2	
80	16.5	13.5	12.5	9.5	10	7	7.5	4	9.5	6.5	13	10	10.5	7.5	18	15	6.5	3.5	8.5	5.5	7	4	
100	18	16	14	12	11.5	9.5	9	6.5	11	9	14.5	12.5	12	10	19.5	17.5	8	6	10	8	8.5	6.5	

Note) Adjust the auto switch after confirming the operating conditions in the actual setting.

Auto Switch Mounting Height

(mm)

Auto switch model	D-A9□ D-M9□ D-M9□W D-M9□A		D-A9□V		D-M9□V D-M9□WV D-M9□AV		D-Z7□ D-Z80 D-Y59□ D-Y7P D-Y7BA D-Y7□W		D-Y69□ D-Y7PV D-Y7□WV		D-P3DW		D-P4DW		D-B5□ D-B64 D-B59W D-G5□ D-K59 D-G5NTL D-G5□W D-K59W D-G5BAL D-G59F		D-A3□ D-G39 D-K39		D-A44		D-A5□ D-A6□ D-A59W		D-F5□ D-J59 D-F5□W D-J59W D-F5BA D-F59F D-F5NT		D-A3□C D-G39C		D-A44C		
	Hs	Ht	Hs	Ht	Hs	Ht	Hs	Ht	Hs	Ht	Hs	Ht	Hs	Ht	Hs	Ht	Hs	Ht	Hs	Ht	Hs	Ht	Hs	Ht	Hs	Ht	Hs	Ht	Hs
40	30	30	31	30	34	30	30	30	30	30	38	30	42.5	33	37	71.5	81.5	38.5	31.5	38	31.5	73	69	81	69				
50	34	34	35	34	38	34	34	34	34	34	42	34	46.5	37.5	42	76.5	86.5	42	35.5	42	35.5	78.5	77	86.5	77				
63	41	41	41.5	41	44	41	41	41	41	41	49	41	52	43	49	83.5	93.5	46.5	43	47	43	85.5	91	93.5	91				
80	49.5	49	50	49	52.5	49	49.5	49	49.5	49	56	49	58.5	51.5	57.5	92	102	53.5	51	53.5	51	94	107	102	107				
100	56.5	56	58.5	56	61	56	56.5	55.5	57.5	55.5	65	56	66	58.5	68	102.5	112.5	61.5	57.5	61	57.5	104	121	112	121				

Table 5

Minimum Stroke for Auto Switch Mounting

Auto switch model	Number of auto switches	Brackets other than center trunnion	Center trunnion				
			ø40	ø50	ø63	ø80	ø100
			n: Number of auto switches (mm)				
D-A9□	2 (Different surfaces and same surface) 1	15	75	80	85	90	
	n	$15 + 40 \frac{(n-2)}{2}$ (n = 2, 4, 6, 8...)	$75 + 40 \frac{(n-4)}{2}$ (n = 4, 8, 12, 16...)	$80 + 40 \frac{(n-4)}{2}$ (n = 4, 8, 12, 16...)	$85 + 40 \frac{(n-4)}{2}$ (n = 4, 8, 12, 16...)	$90 + 40 \frac{(n-4)}{2}$ (n = 4, 8, 12, 16...)	
D-A9□V	2 (Different surfaces and same surface) 1	10	50	55	60	65	
	n	$10 + 30 \frac{(n-2)}{2}$ (n = 2, 4, 6, 8...)	$50 + 30 \frac{(n-4)}{2}$ (n = 4, 8, 12, 16...)	$55 + 30 \frac{(n-4)}{2}$ (n = 4, 8, 12, 16...)	$60 + 30 \frac{(n-4)}{2}$ (n = 4, 8, 12, 16...)	$65 + 30 \frac{(n-4)}{2}$ (n = 4, 8, 12, 16...)	
D-M9□ D-M9□W	2 (Different surfaces and same surface) 1	15	80	85	90	95	
	n	$15 + 40 \frac{(n-2)}{2}$ (n = 2, 4, 6, 8...)	$80 + 40 \frac{(n-4)}{2}$ (n = 4, 8, 12, 16...)	$85 + 40 \frac{(n-4)}{2}$ (n = 4, 8, 12, 16...)	$90 + 40 \frac{(n-4)}{2}$ (n = 4, 8, 12, 16...)	$95 + 40 \frac{(n-4)}{2}$ (n = 4, 8, 12, 16...)	
D-M9□V D-M9□WV	2 (Different surfaces and same surface) 1	10	55	60	65	70	
	n	$10 + 30 \frac{(n-2)}{2}$ (n = 2, 4, 6, 8...)	$55 + 30 \frac{(n-4)}{2}$ (n = 4, 8, 12, 16...)	$60 + 30 \frac{(n-4)}{2}$ (n = 4, 8, 12, 16...)	$65 + 30 \frac{(n-4)}{2}$ (n = 4, 8, 12, 16...)	$70 + 30 \frac{(n-4)}{2}$ (n = 4, 8, 12, 16...)	
D-M9□A	2 (Different surfaces and same surface) 1	15	80	85	95	100	
	n	$15 + 40 \frac{(n-2)}{2}$ (n = 2, 4, 6, 8...)	$80 + 40 \frac{(n-4)}{2}$ (n = 4, 8, 12, 16...)	$85 + 40 \frac{(n-4)}{2}$ (n = 4, 8, 12, 16...)	$95 + 40 \frac{(n-4)}{2}$ (n = 4, 8, 12, 16...)	$100 + 40 \frac{(n-4)}{2}$ (n = 4, 8, 12, 16...)	
D-M9□AV	2 (Different surfaces and same surface) 1	10	60	65	70	75	
	n	$10 + 30 \frac{(n-2)}{2}$ (n = 2, 4, 6, 8...)	$60 + 30 \frac{(n-4)}{2}$ (n = 4, 8, 12, 16...)	$65 + 30 \frac{(n-4)}{2}$ (n = 4, 8, 12, 16...)	$70 + 30 \frac{(n-4)}{2}$ (n = 4, 8, 12, 16...)	$75 + 30 \frac{(n-4)}{2}$ (n = 4, 8, 12, 16...)	
D-A5□/A6 D-F5□/J5 D-F5□W/J59W D-F5BA/F59F	2 (Different surfaces and same surface) 1	15	90	100	110	120	
	n (Same surface)	$15 + 55 \frac{(n-2)}{2}$ (n = 2, 4, 6, 8...)	$90 + 55 \frac{(n-4)}{2}$ (n = 4, 8, 12, 16...)	$100 + 55 \frac{(n-4)}{2}$ (n = 4, 8, 12, 16...)	$110 + 55 \frac{(n-4)}{2}$ (n = 4, 8, 12, 16...)	$120 + 55 \frac{(n-4)}{2}$ (n = 4, 8, 12, 16...)	
D-A59W	2 (Different surfaces and same surface) 1	20	90	100	110	120	
	n (Same surface)	$20 + 55 \frac{(n-2)}{2}$ (n = 2, 4, 6, 8...)	$90 + 55 \frac{(n-4)}{2}$ (n = 4, 8, 12, 16...)	$100 + 55 \frac{(n-4)}{2}$ (n = 4, 8, 12, 16...)	$110 + 55 \frac{(n-4)}{2}$ (n = 4, 8, 12, 16...)	$120 + 55 \frac{(n-4)}{2}$ (n = 4, 8, 12, 16...)	
	1	15	90	100	110	120	
D-F5NT	2 (Different surfaces and same surface) 1	25	110	120	130	140	
	n (Same surface)	$25 + 55 \frac{(n-2)}{2}$ (n = 2, 4, 6, 8...)	$110 + 55 \frac{(n-4)}{2}$ (n = 4, 8, 12, 16...)	$120 + 55 \frac{(n-4)}{2}$ (n = 4, 8, 12, 16...)	$130 + 55 \frac{(n-4)}{2}$ (n = 4, 8, 12, 16...)	$140 + 55 \frac{(n-4)}{2}$ (n = 4, 8, 12, 16...)	
D-B5□/B64 D-G5□/K59 D-G5□W D-K59W D-G5BA D-G59F D-G5NT	2 Different surfaces	15	90	100	110		
	Same surface	75					
	n Different surfaces	$15 + 50 \frac{(n-2)}{2}$ (n = 2, 4, 6, 8...)	$90 + 50 \frac{(n-4)}{2}$ (n = 4, 8, 12, 16...)	$100 + 50 \frac{(n-4)}{2}$ (n = 4, 8, 12, 16...)	$110 + 50 \frac{(n-4)}{2}$ (n = 4, 8, 12, 16...)		
	Same surface	$75 + 50 (n-2)$ (n = 2, 3, 4...)	$90 + 50 (n-2)$ (n = 2, 4, 6, 8...)	$100 + 50 (n-2)$ (n = 2, 4, 6, 8...)	$110 + 50 (n-2)$ (n = 2, 4, 6, 8...)		
	1	10	90	100	110		
D-B59W	2 Different surfaces	20	90	100	110		
	Same surface	75					
	n Different surfaces	$20 + 50 \frac{(n-2)}{2}$ (n = 2, 4, 6, 8...)	$90 + 50 \frac{(n-4)}{2}$ (n = 4, 8, 12, 16...)	$100 + 50 \frac{(n-4)}{2}$ (n = 4, 8, 12, 16...)	$110 + 50 \frac{(n-4)}{2}$ (n = 4, 8, 12, 16...)		
	Same surface	$75 + 50 (n-2)$ (n = 2, 3, 4...)	$90 + 50 (n-2)$ (n = 2, 4, 6, 8...)	$100 + 50 (n-2)$ (n = 2, 4, 6, 8...)	$110 + 50 (n-2)$ (n = 2, 4, 6, 8...)		
	1	15	90	100	110		
D-A3□ D-G39 D-K39	2 Different surfaces	35	75	80	90		
	Same surface	100	100	100	100		
	n Different surfaces	$35 + 30 (n-2)$ (n = 2, 3, 4...)	$75 + 30 (n-2)$ (n = 2, 4, 6, 8...)	$80 + 30 (n-2)$ (n = 2, 4, 6, 8...)	$90 + 30 (n-2)$ (n = 2, 4, 6, 8...)		
	Same surface	$100 + 100 (n-2)$ (n = 2, 3, 4...)	$100 + 100 (n-2)$ (n = 2, 4, 6, 8...)				
	1	10	75	80	90		

Table 6

Minimum Stroke for Auto Switch Mounting

Auto switch model	Number of auto switches	Brackets other than center trunnion	Center trunnion				
			ø40	ø50	ø63	ø80	ø100
			n: Number of auto switches (mm)				
D-A44	2	Different surfaces	35	75	80	90	
		Same surface	55				
	n	Different surfaces	$35 + 3(n - 2)$ (n = 2, 3, 4...)	$75 + 30(n - 2)$ (n = 2, 4, 6, 8...)	$80 + 30(n - 2)$ (n = 2, 4, 6, 8...)	$90 + 30(n - 2)$ (n = 2, 4, 6, 8...)	
		Same surface	$55 + 50(n - 2)$ (n = 2, 3, 4...)	$75 + 50(n - 2)$ (n = 2, 4, 6, 8...)	$80 + 50(n - 2)$ (n = 2, 4, 6, 8...)	$90 + 50(n - 2)$ (n = 2, 4, 6, 8...)	
	1	10	75	80	90		
D-A3□C D-G39C D-K39C	2	Different surfaces	20	75	80	90	
		Same surface	100				
	n	Different surfaces	$20 + 35(n - 2)$ (n = 2, 3, 4...)	$75 + 35(n - 2)$ (n = 2, 4, 6, 8...)	$80 + 35(n - 2)$ (n = 2, 4, 6, 8...)	$90 + 35(n - 2)$ (n = 2, 4, 6, 8...)	
		Same surface	$100 + 100(n - 2)$ (n = 2, 3, 4, 5...)		$100 + 100(n - 2)$ (n = 2, 4, 6, 8...)		
	1	10	75	80	90		
D-A44C	2	Different surfaces	20	75	80	90	
		Same surface	55				
	n	Different surfaces	$20 + 35(n - 2)$ (n = 2, 3, 4...)	$75 + 35(n - 2)$ (n = 2, 4, 6, 8...)	$80 + 35(n - 2)$ (n = 2, 4, 6, 8...)	$90 + 35(n - 2)$ (n = 2, 4, 6, 8...)	
		Same surface	$55 + 50(n - 2)$ (n = 2, 3, 4...)	$75 + 50(n - 2)$ (n = 2, 4, 6, 8...)	$80 + 50(n - 2)$ (n = 2, 4, 6, 8...)	$90 + 50(n - 2)$ (n = 2, 4, 6, 8...)	
	1	10	75	80	90		
D-Z7□Z80 D-Y59□Y7P D-Y7□W	2 (Different surfaces and same surface) 1	15	80	85	90	95	105
	n	$15 + 40 \frac{(n-2)}{2}$ (n = 2, 4, 6, 8...)	$80 + 40 \frac{(n-4)}{2}$ (n = 4, 8, 12, 16...)	$85 + 40 \frac{(n-4)}{2}$ (n = 4, 8, 12, 16...)	$90 + 40 \frac{(n-4)}{2}$ (n = 4, 8, 12, 16...)	$95 + 40 \frac{(n-4)}{2}$ (n = 4, 8, 12, 16...)	$105 + 40 \frac{(n-4)}{2}$ (n = 4, 8, 12, 16...)
D-Y69□Y7PV D-Y7□WV	2 (Different surfaces and same surface) 1	10	65		75	80	90
	n	$10 + 30 \frac{(n-2)}{2}$ (n = 2, 4, 6, 8...)	$65 + 30 \frac{(n-4)}{2}$ (n = 4, 8, 12, 16...)		$75 + 30 \frac{(n-4)}{2}$ (n = 4, 8, 12, 16...)	$80 + 30 \frac{(n-4)}{2}$ (n = 4, 8, 12, 16...)	$90 + 30 \frac{(n-4)}{2}$ (n = 4, 8, 12, 16...)
D-Y7BA	2 (Different surfaces and same surface) 1	20	95		100	105	110
	n	$20 + 45 \frac{(n-2)}{2}$ (n = 2, 4, 6, 8...)	$95 + 45 \frac{(n-4)}{2}$ (n = 4, 8, 12, 16...)		$100 + 45 \frac{(n-4)}{2}$ (n = 4, 8, 12, 16...)	$105 + 45 \frac{(n-4)}{2}$ (n = 4, 8, 12, 16...)	$110 + 45 \frac{(n-4)}{2}$ (n = 4, 8, 12, 16...)
D-P3DW	2 (Different surfaces and same surface) 1	15	85				
	n	$15 + 50 \frac{(n-2)}{2}$ (n = 2, 4, 6, 8...)	$85 + 50 \frac{(n-4)}{2}$ (n = 4, 8, 12, 16...)				
D-P4DW	2 (Different surfaces and same surface) 1	15	120	130	140		
	n	$15 + 65 \frac{(n-2)}{2}$ (n = 2, 4, 6, 8...)	$120 + 65 \frac{(n-4)}{2}$ (n = 4, 8, 12, 16...)	$130 + 65 \frac{(n-4)}{2}$ (n = 4, 8, 12, 16...)	$140 + 65 \frac{(n-4)}{2}$ (n = 4, 8, 12, 16...)		

Table 7

Other than the applicable auto switches listed in "How to Order", the following auto switches can be mountable.

Refer to Best Pneumatics No.2 for detailed specifications.

Type	Model	Electrical entry	Features
Reed	D-A93V/A96V	Grommet (Perpendicular)	—
	D-A90V		Without indicator light
	D-A53/A56/B53/Z73/Z76	Grommet (In-line)	—
	D-A67/Z80		Without indicator light
Solid state	D-M9NV/M9PV/M9BV	Grommet (Perpendicular)	—
	D-Y69A/Y69B/Y7PV		Diagnostic indication (2-color indication)
	D-M9NWV/M9PWV/M9BWW		—
	D-Y7NWW/Y7PWW/Y7BWW		Water resistant (2-color)
	D-M9NAV/M9PAV/M9BAV		—
	D-Y59A/Y59B/Y7P	Grommet (In-line)	—
	D-F59/F5P/J59		Diagnostic indication (2-color indication)
	D-Y7NW/Y7PW/Y7BW		Water resistant (2-color)
	D-F59W/F5PW/J59W		—
	D-F5BA/Y7BA		With timer
	D-F5NT/G5NT		Magnetic field resistant (2-color)
D-P5DW			

* With pre-wired connector is also available for solid state auto switches. For details, refer to pages 1328 and 1329 in Best Pneumatics No. 2.

* Normally closed (NC = b contact) solid state auto switches (D-F9G/F9H/Y7G/Y7H) are also available. For details, refer to pages 1290 and 1292 in Best Pneumatics No. 2.

* Wide range detection type, solid state auto switch (D-G5NBL) is also available. For details, refer to page 1320 in Best Pneumatics No. 2.

Auto switch Connection and Example

Sink Input Specifications

3-wire, NPN

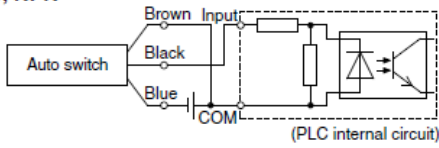

2-wire

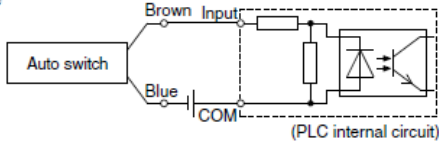

Source Input Specifications

3-wire, PNP

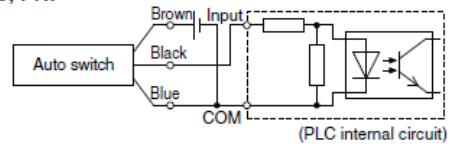

2-wire

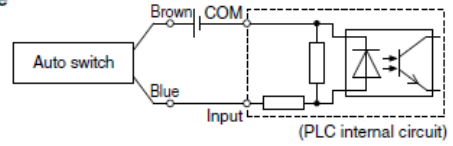

Connect according to the applicable PLC input specifications, as the connection method will vary depending on the PLC input specifications.

Example of AND (Series) and OR (Parallel) Connection

3-wire, AND connection for NPN output (Using relays)

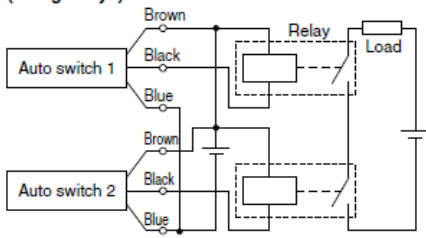

(Performed with auto switches only)

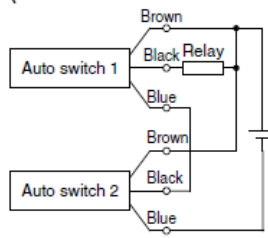

3-wire, OR connection for NPN output

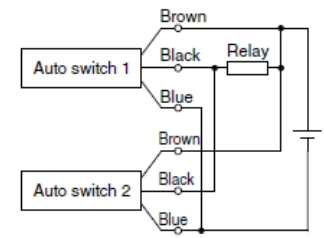

3-wire, AND connection for PNP output (Using relays)

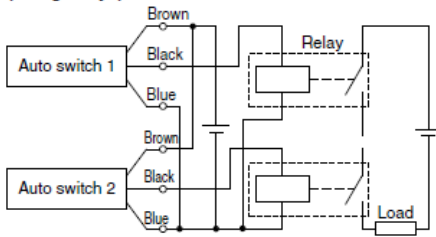

(Performed with auto switches only)

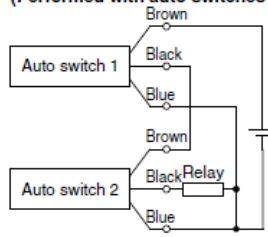

3-wire, OR connection for PNP output

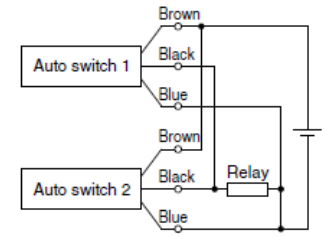

2-wire, AND connection

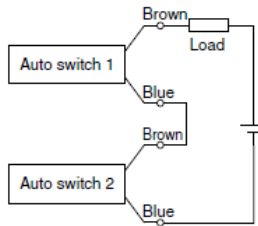

When two auto switches are connected in series, malfunction may occur because the load voltage will decrease in the ON state. The indicator lights will light up when both of the auto switches are in the ON state.

$$\begin{aligned} \text{Load voltage at ON} &= \text{Power supply voltage} - \text{Residual voltage} \times 2 \text{ pcs.} \\ &= 24 \text{ V} - 4 \text{ V} \times 2 \text{ pcs.} \\ &= 16 \text{ V} \end{aligned}$$

Example: Power supply is 24 VDC
Auto switch internal voltage drop 4 V

2-wire, AND connection

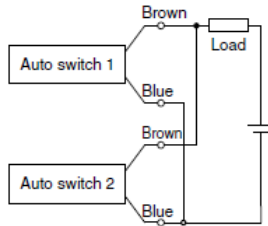

(Solid state)
When two auto switches are connected in parallel, malfunction may occur because the load voltage will increase in the OFF state.

(Reed)
Because there is no leakage current, the load voltage will not increase in the OFF state. However, depending on the number of auto switches in the ON state, the indicator lights may sometimes grow dim or not light up, due to the dispersion and reduction of the current flowing to the auto switches.

$$\begin{aligned} \text{Load voltage at OFF} &= \text{Leakage current} \times 2 \text{ pcs.} \times \text{Load impedance} \\ &= 1 \text{ mA} \times 2 \text{ pcs.} \times 3 \text{ k}\Omega \\ &= 6 \text{ V} \end{aligned}$$

Example: Load impedance is 3 kΩ
Auto switch leakage current 1 mA

3. Maintenance

3-1. Checks

The following checks are required for proper cylinder operation.

- 1) Smooth operation
- 2) Changes in piston speed and cycle time
- 3) Abnormal stroke
- 4) Looseness of mounting bolt and rod end nuts
- 5) Looseness of mounting frame and excessive deflection
- 6) Internal and external leakage (Change in output)
- 7) Damage to the piston rod sliding surface
- 8) Clogging and discharge drainage of the air filter
- 9) Lubrication of rotating parts (double knuckle joint, clevis pin, etc.)
- 10) Position of auto switches

When any abnormality is found as a result of checking the points above, eliminate causes and take necessary measures such as retightening screws and the application of grease. Contact SMC sales if it is necessary to repair the cylinder.

Warning

- **As a minimum, maintenance should be performed according to the above items. Perform additional maintenance as necessary.**
Improper handling can cause damage and malfunction of equipment and machinery.
- **Removal of equipment, and supply/exhaust of compressed air.**
Ensure that drop prevention measures and safe lock out of the moving parts are taken, the power of the facility and supply air is shut off and the compressed air in the system is exhausted before removing the equipment.
Before restarting the equipment, confirm that measures are taken to prevent sudden action.

3-2. Replacement of seals

It is possible to replace the rod seal, cushion seal, piston seal, cylinder tube gasket and wear ring.

Contact SMC sales if it is necessary to replace parts other than those mentioned above.

Warning

- **Only people who have sufficient knowledge and experience are allowed to replace seals.**
The person who disassembles and reassembles the cylinder is responsible for the safety of the product.

Caution

- **When replacing seals, carefully handle parts to prevent injury to your hands or fingers on the corners of parts.**

3-2-1. Disassembly / Reassembly

Caution

- Disassemble and assemble the cylinder on a clean cloth in a clean location. Perform on a clean cloth.
- Make sure no particles are present. Do not scratch the seals.
- A tie-rod nut should be fitted on the shorter thread to the end of tie-rod by hand. And affix to the cylinder.
- Another tie-rod nut should be mounted on the cover at the opposite side of the first tie-rod nut, and tightened so that the tensile force is even.
- When they are tightened, please use proper tightening torque. (Refer to Table 2)

It same for mounting bracket {Refer to Table 10 (P29)}

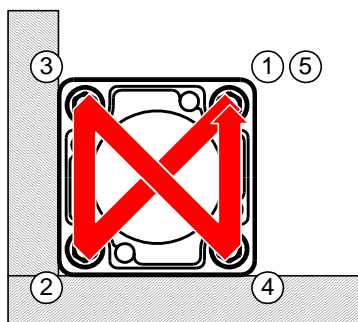
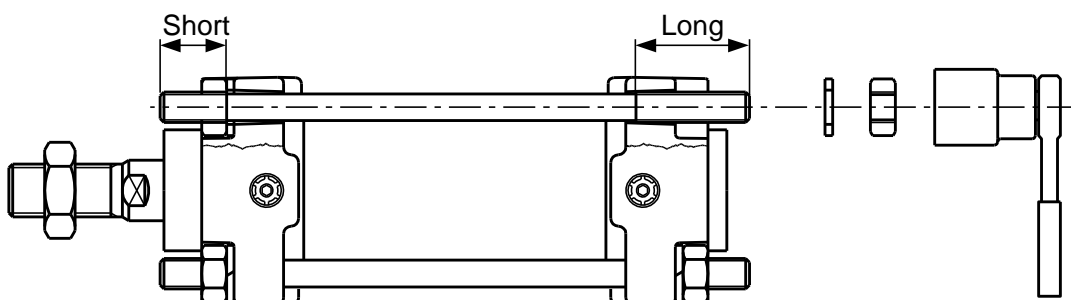

Tie rod tightening order.

Table 8. Tightening torque

Bore size	Socket	Tightening torque[N·m]
40,50	13 (M8)	7.4
63	17 (M10)	20
80,100	19 (M12)	29

3-2-2. Removal of seals

1) Rod seal

Insert a precision screwdriver from the front of the cover to pull out the seal as shown in Fig. 12.

Caution

- Take care not to damage the seal groove of the cover at this time.

2) Piston seal

Wipe off grease around piston seal first to make seal removal easier.

As shown in Fig. 13, hold the piston seal with one hand and push it into the groove so that the piston seal can be lifted off and pulled out without using a precision screwdriver.

The groove of the rod cover is deep, so if the rod seal is removed with a precision screwdriver, it might be damaged.

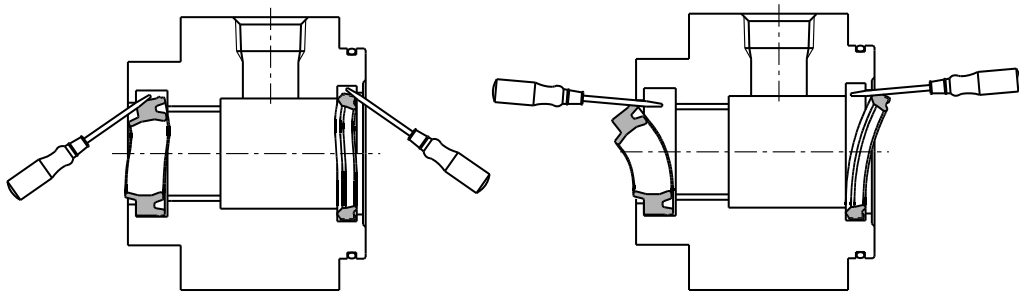

Fig 12. Remove rod seal

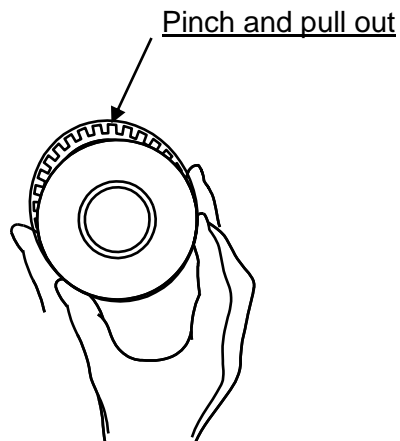

Fig 13. Remove piston seal

3) Tube gasket

Pull out with the precision screwdriver.

3-2-3. Grease

Caution

- Use SMC's recommended grease.
Grease pack part number: GR-S-010 (10g), GR-S-020 (20g)
Refer to Page 32 for made to order product (XC85).

1) ① Rod seal

Apply a thin layer of grease to all surfaces of the new seal to make it easy to mount the rod seal and improve sealing.

Fill the groove of the seal with grease, which is necessary for operation.

2) ② Piston seal

Apply a thin layer of grease to the all surfaces of the piston seal to make it easy to mount the seal.

3) ⑤ Cushion seal ⑦ Tube gasket

Apply a thin layer of grease to all surfaces of the tube gasket to make it easy to mount the gasket.

4) Parts of cylinder

Grease is applied to the locations shown in Fig. 14. The amount of grease per cylinder of 100 stroke is shown in attached table 9. Roughly, one scoop with a forefinger is approximately 3g.

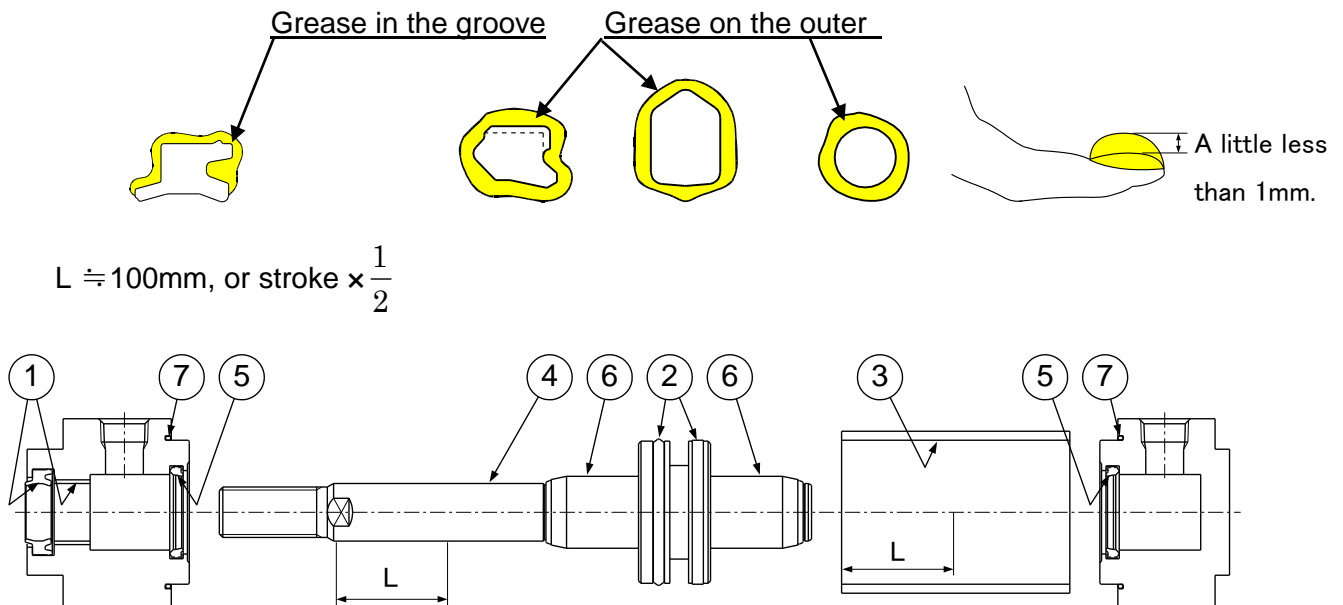

Fig. 14 Position for application of grease

Table 9 Amount of grease

units: g

Stroke \ Bore	Φ40	Φ50	Φ63	Φ80	Φ100	Position for grease
At 100st	3 to 4	3 to 5	4 to 5	6 to 8	8 to 10	① ② ③ ④ ⑤ ⑥ ⑦
50st added	1	1	1.5	2	3	③ ④

3-2-4. Mounting of seals

1) Rod seal, Cushion seal (Fig.14, ① ⑤)

Pay attention to the mounting direction of the seal.

Apply grease all over the seal and inner surface of the bushing as shown in Fig. 15. If it is difficult to apply grease, for example to a small bore diameter, use a precision screwdriver. Do not scratch any surface with the screwdriver.

2) Piston seal (Fig. 14, ②)

Mount with care not to twist the piston seal. Apply grease to the seal groove and outer circumference by rubbing grease into them as shown in Fig. 16.

3) Tube gasket (Fig. 14, ⑦)

Mount with care not to twist the tube gasket.

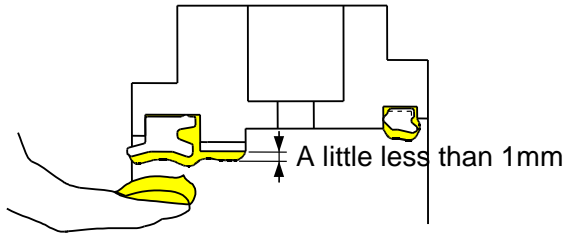

Fig15. Rod seal

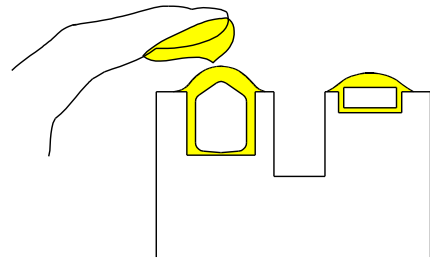
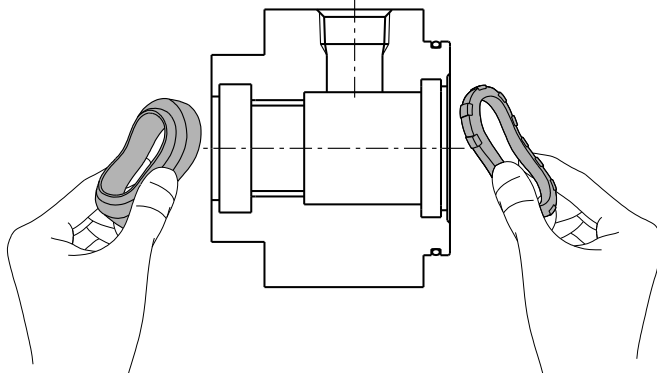
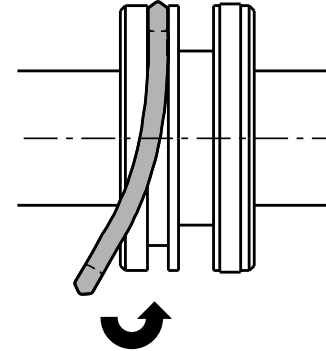

Fig16. Piston seal



Mount rod seal and cushion seal



Mount piston seal

4) Use a socket wrench when the bracket is replaced.

If other tools are used, the nut or other parts may be deformed or the work efficiency may decrease. For applicable sockets, please refer to the table below.

Table 10

Bore size(mm)	Nut	Width across flats	Tightening torque(N·m)
40,50	JIS B1181 class 3 IntermediateM8X1.25	13	7.4
63	JIS B1181 class 3 IntermediateM10X1.25	17	20
80,100	JIS B1181 class 3 IntermediateM12X1.75	19	29

5)When replacing mounting brackets, tie-rod nuts on the cylinder body become loosened.

Mount the mounting bracket after tightening the tie-rod nut with the appropriate tightening torque again .

6) The trunnion type cylinder requires mounting accuracy.

The trunnion type cylinder may lose dimensional accuracy and malfunction when it is disassembled and reassembled because the axial center of the trunnion and that of the cylinder will not be aligned easily.

! Caution

- Confirm that there is no problem with operation and air tightness after assembly.

3-3. Consumable parts

3-3-1. Replacement parts

	φ40	φ50	φ63	φ80	φ100
Seal kit no.	CA2-40Z-PS	CA2-50Z-PS	CA2-63Z-PS	CA2-80Z-PS	CA2-100Z-PS
Contents of the seal kit	Rod seal 1 pc Piston seal 1 pc Cushion seal 2 pc Cylinder tube gasket 2 pc				

Note) Seal kits include grease pack.

Grease pack part number: GR-S-010(10g) , GR-S-020 (20g)

B

	Wear ring number
φ40	C1A040-07-305B
φ50	C1A050-07-306B
φ63	C1A063-07-307B
φ80	C1A080-07-308B
φ100	C1A100-07-309B

Caution

- The seal is not delivered in sealed packaging for storage independently, so it must be used within 1 year.

3-3-2. Storage of seals

Caution

- Store seals in sealed packaging such as polyethylene bag and place it in a box.
- Avoid locations exposed to direct sunlight and high temperature and humidity. In particular, isolate from equipment that can generate heat, radiation and ozone.
- Do not stack a lot of seals, or deform or damage seals by putting a heavy object on top of them.
- White particles can emerge from the surface of the seal during storage, but they do not affect its performance.

3-4. Troubleshooting

Failure	Cause	Countermeasures
The piston rod does not operate smoothly.	Improper alignment at mounting	- Alignment and adjustment at mounting
	Lateral load is applied.	- Provide a proper guide. - Modify the mounting.
	Operated below the lower speed limit	- Remove factors to change load.
	High load factor	- Increase pressure. - Use larger cylinders.
	Speed controllers are meter-in control.	- Change to meter-out control.
	The cushion valve is tightened too much or completely closed.	- Readjust the cushion valve.
Damage/ Deformation	Impact force by high speed operation.	- Adjust the cushion. - Lower speed. - Reduce load. - Provide shock absorbing mechanism externally. (Consider using shock absorbers etc.)
	Lateral load is applied.	- Provide a proper guide. - Modify the mounting.

4. Made to order product (XC85).

Made to order product below uses special grease.

(If mixed with other grease, optimum performance cannot be achieved.)

4-1. Food Machinery Grease Specification

Standard models -XC85

Grease pack part number: GR-H-010(10g)

Nonfood compound incidental contact.

Operating Environment



Caution

Environment for installing cylinder

Do not use in food zone.

<Not installable>

Food zone.....An environment where food which will be sold as merchandize, directly touches the cylinder's components.

Splash zone.....An environment where food which will not be sold as merchandize, directly touches the cylinder's components.

<Installable>

Non-food zone.....An environment where there is no contact with food.

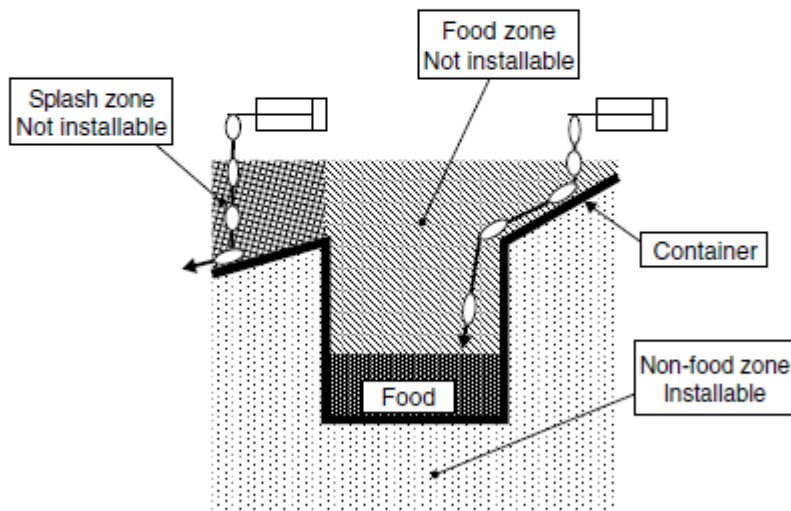

* When the product is used in an area of liquid splash, or a water resistant function is required for the product, please consult SMC.

5. Basic Circuit for Cylinder Operation

The basic circuit for operating the product with air filter, regulator, solenoid valve and speed controller (meter-out) is shown in the following figure.

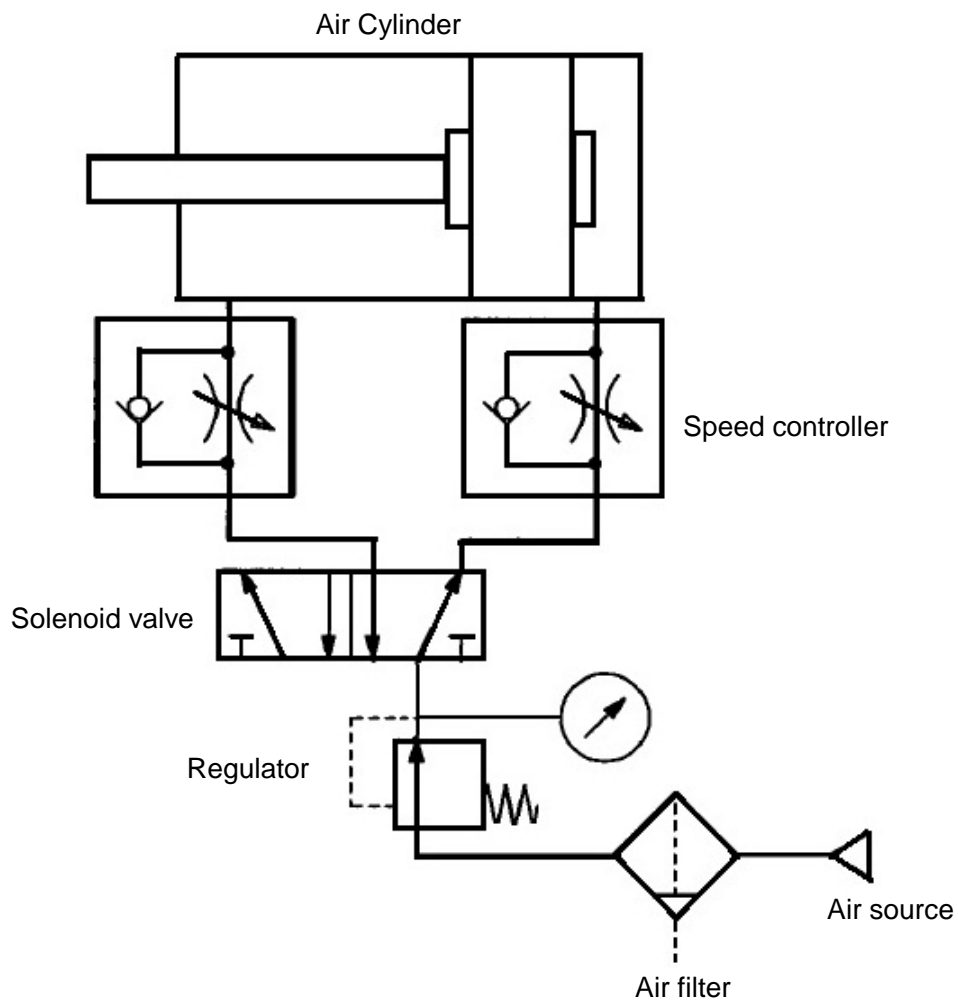

Fig. 17 Basic Circuit

6. Construction

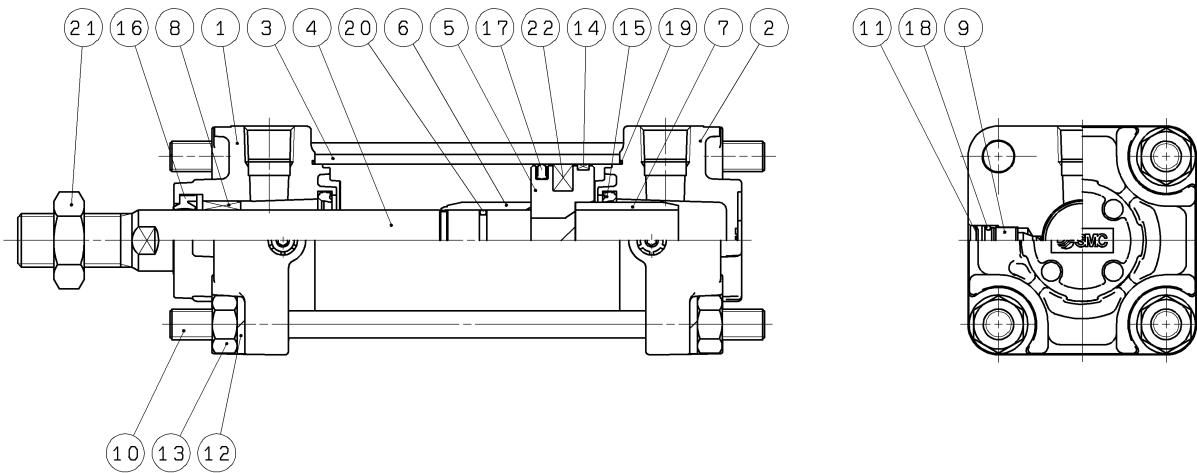

Fig 18. Standard product: Double acting/single rod

Table 12 Parts list

No.	Description	Qty
1	Rod cover	1
2	Head cover	1
3	Cylinder tube	1
4	Piston rod	1
5	Piston	1
6	Cushion ring	1
7	Cushion ring B	1
8	Bushing	1
9	Cushion valve	2
10	Tie-rod	4
A 11	Retaining ring	2
12	Spring washer	8
13	Tie-rod nut	8
14	Wear ring	1
15	Cushion seal	2
16	Rod seal	1
17	Piston seal	1
18	Cushion valve seal	2
19	Cylinder tube gasket	2
20	Piston gasket	1
21	Rod end nut	1
22	Magnet	(1)

Revision history

- A XC5 delete
Match sentences with the catalog
- B Corrected the part number of the wear ring

SMC Corporation

4-14-1, Sotokanda, Chiyoda-ku, Tokyo 101-0021 JAPAN
Tel: + 81 3 5207 8249 Fax: +81 3 5298 5362
URL <http://www.smcworld.com>