



## Serial Communication Manual

PRODUCT NAME

**Air cooled Thermo-con (Compact type)**

MODEL / Series / Product Number

***HEF002-A6***



**SMC Corporation**

Keep available whenever necessary.

This manual is copyrighted and all rights are reserved by SMC Corporation, and may not, in whole or in part, be copied, photocopied or translated without prior written consent of SMC.



### History

Version	Preface	Contents	Chap.1	Chap.2	Chap.3	Chap.4
1.0	Jul/7/22	Jul/7/22	Jul/7/22	Jul/7/22	Jul/7/22	Jul/7/22

### Record of Changes

Version	Contents	Date
1.0	First edition	Jul/7/22

## Preface

Thank you very much for purchasing SMC Thermo-con.

This manual contains description for communication protocol of this product for your full benefit from this product.

Read the operation manual carefully before use of this product, and understand the outline of the product and safety instructions well. Instructions in the categories, “Danger”, “Warning” and “Caution”, are important for safety and must be duly followed.

Please contact the following for any question and unclear points regarding the Thermo-con.

SMC Corporation R&D Center  
Product Development Division-6  
Address: 4-2-2, KINUNODAI, TSUKUBAMIRAI-CITY, IBARAKI-KEN 300-2493, JAPAN  
Phone: +81-297-52-6666  
Fax: +81-297-20-5007  
E-mail: kaihatsu\_6\_g3@smcjpn.co.jp

Notice: The content of this manual can be revised without a previous notice.

# Contents

<b>1</b>	<b>PREPARATION FOR COMMUNICATION</b>	<b>1-1</b>
<b>2</b>	<b>OPTIONS OF COMMUNICATION METHOD</b>	<b>2-1</b>
2.1	COMMUNICATION PROCEDURE	2-1
<b>3</b>	<b>COMMUNICATION FORMAT</b>	<b>3-1</b>
3.1	TYPE OF MESSAGE	3-1
3.2	CONTENT OF COMMUNICATION	3-1
3.3	COMPOSITION OF REQUIRED MESSAGE (FROM MASTER TO THE PRODUCT)	3-2
3.4	COMPOSITION OF RESPONSE MESSAGE (FROM THE PRODUCT TO MASTER)	3-3
3.5	EXPLANATION OF CODE	3-4
3.6	CAUTIONS FOR COMMUNICATION	3-6
3.7	COMMUNICATION EXAMPLE	3-7
3.8	CONNECTION	3-9
3.9	IDENTIFICATION CODE LIST	3-9
3.10	ASCII CODE LIST	3-9
<b>4</b>	<b>TROUBLESHOOTING</b>	<b>4-1</b>



## 1 Preparation for Communication

Make preparation for using communication facility as follows.

- 1) Turn off the power switch of Thermo-con. (Detach the communication connector when the power switch of the thermo-con is turning off.)
- 2) Connect communication cable to communication connector (RS-485 or RS-232C) of Thermo-con.
  - Use twist pair shield cable as communication cable.
  - Connect the host and thermo-con with the cross cable for RS-232C and the straight cable for RS-485.
  - Connect shielded cable of communication cable to communication connector and drop it to FG(frame ground).
  - Connection drawing for communication is shown in the Figures 1-1, Figures 1-2.
  - Length of communication cable for RS-485 shall be limited to around 500[m] in total, and that for RS-232C shall be 15[m].
  - If communication cable for RS-485 is longer, connect terminating resistance ( $220\ \Omega$ , 1/2W) to each + and - terminal of the host computer and the farthest Thermo-con.
- 3) Turn on the power switch of Thermo-con.
- 4) Set the communication method (page 2-1) for all Thermo-con connected. (Refer the operation manual (DOC1003077) how to set the communication method parameters.)
- 5) That's all for preparation of communication. Then if a communication command from the host computer is given, each Thermo-con will respond.

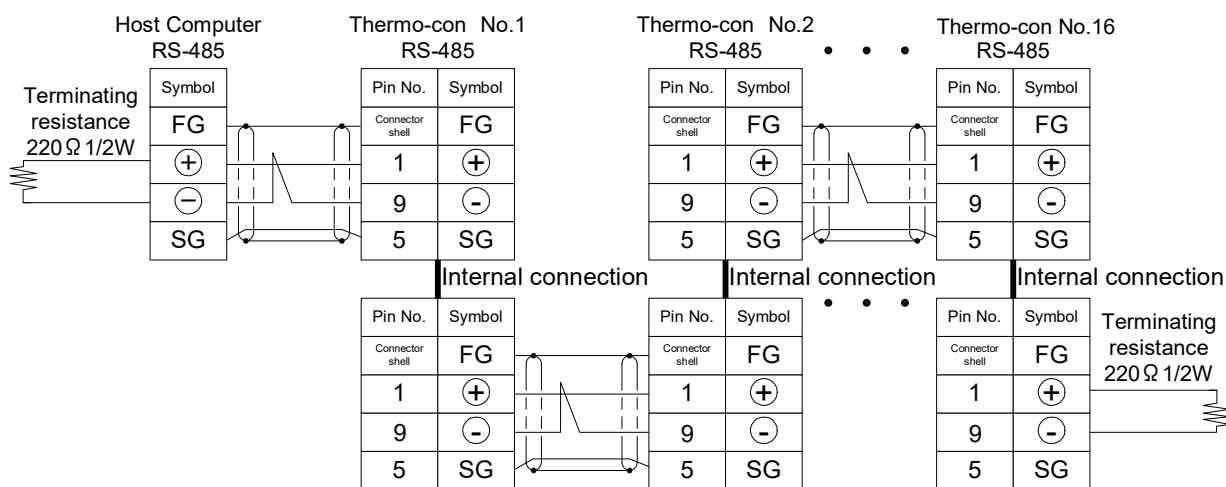

**Figure1-1 Communication Connection (RS-485)**

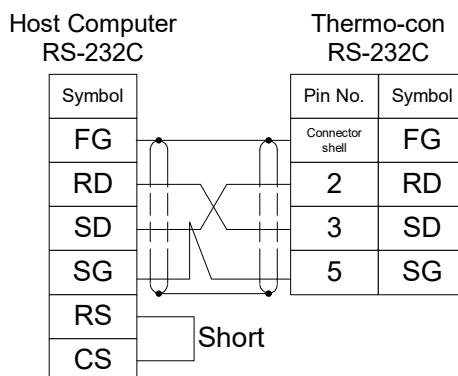

**Figure1-2 Communication Connection (RS-232C)**





## 2 Options of Communication Method

Standards·····	RS-485, <u>RS-232C</u>
Circuit type·····	Half duplex
Communication type·····	Asynchronous
Communication speed·····	2400,4800, <u>9600</u> ,19200, 38400 bps
Character code·····	ASCII
Parity·····	<u>None</u> , even number, odd number
Start bit·····	1 bit
Data length·····	7 bit, <u>8 bit</u> .
Stop bit·····	1 bit, <u>2 bit</u> .
BCC check·····	<u>Disable</u> , Enable
Address·····	<u>1</u> to 99

Note: Values underlined indicate default values.  
It is set to these values when delivered.

### 2.1 Communication Procedure

This product receives a “request message” from the master computer and sends back a corresponding “response message”. It does not send a message firstly.

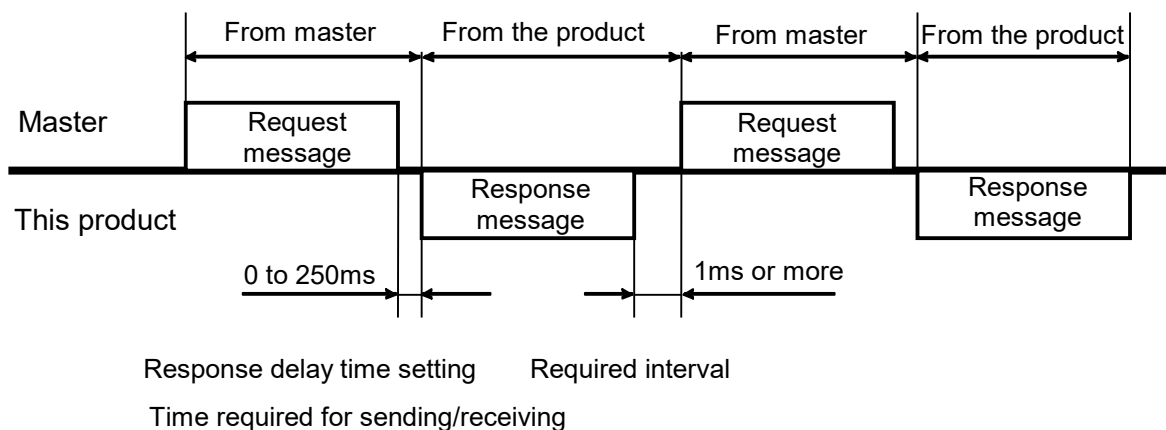



### 3 Communication Format

#### 3.1 Type of Message

The type of message can essentially be divided into the following categories.

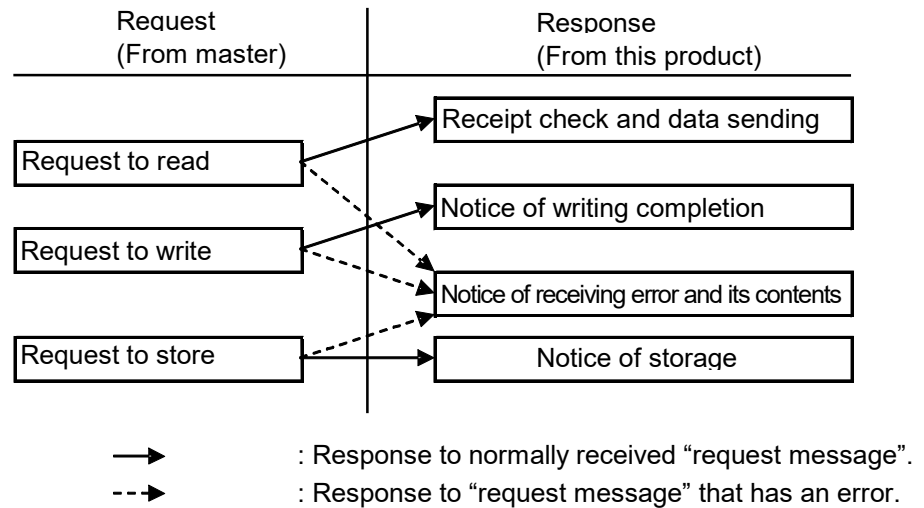

All codes, including STX and data (except for BCC), are expressed with ASCII code. When the master is programmed, refer to page 3-9 "3.9 Identification Code List" and "3.10 ASCII Code List".

#### 3.2 Content of Communication

The content that can be communicated is as follows:

- 1) Reading of measured temperature
- 2) Setting and reading of target temperature
- 3) Setting and reading of offset value
- 4) Storage of set value
- 5) Setting and reading of operation mode

##### [Tips]

All set values input by communication function are not stored. If they need to be stored, send a request message to store them in accordance with page 3-2 "3.3 Composition of Required Message (from master to the product)".

### 3.3 Composition of Required Message (from master to the product)

Refer to page 3-4 “3.5 Explanation of Code” for codes 1 to 7.

■ **Composition of request message to read**

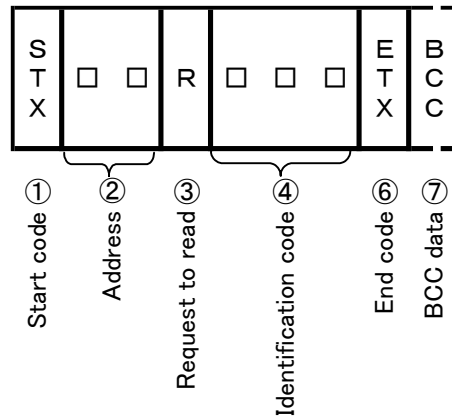

■ **Composition of request message to write**

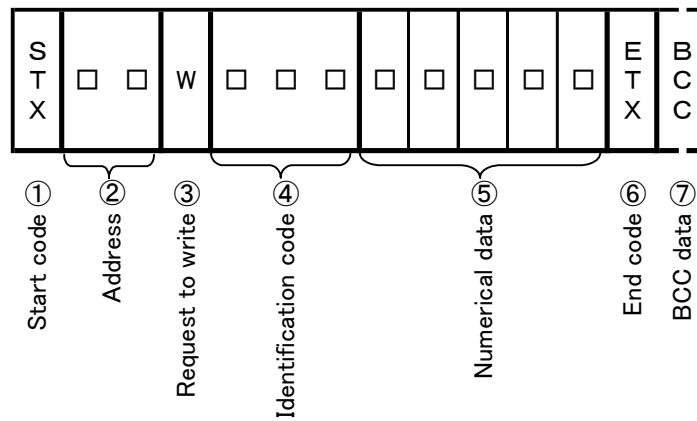

■ **Composition of request message to store**

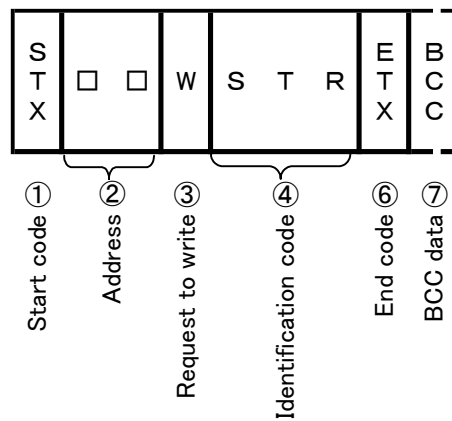

### 3.4 Composition of Response Message (from the product to master)

Refer to page 3-4 “3.5 Explanation of Code” for codes 1 to 10.

#### ■ Response message to request message to read

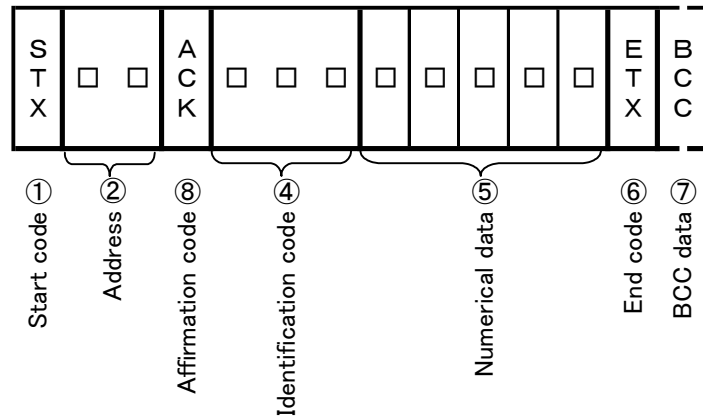

#### ■ Response message to request message to write and store

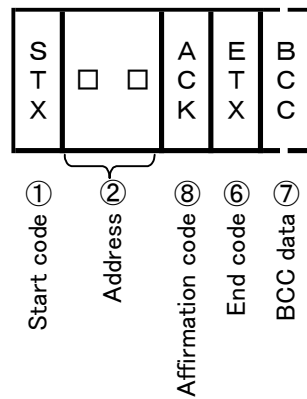

#### ■ Response message to error

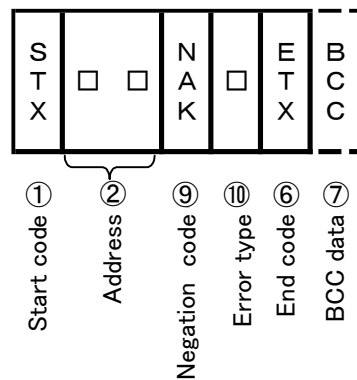

### 3.5 Explanation of Code

① STX

The code necessary for the receiver to detect the beginning of a message. It is put at the beginning of sent characters.

② Address

The address to which (this product) the master communicates. The address in a response message from this product shows where the message is sent.

③ Content

One of two symbols, R or W.

R: Read data from the product

W: Write or store data to the product

④ Identification

The classification symbol (identification code) of read or written data with 3 digit alphabetical ASCII codes. Refer to page 3-9 “3.9 Identification Code List”.

⑤ Numeric data

Read or written data with 5 digits regardless of its type.

Minus data: “- (symbol for minus)” is displayed at the 1<sup>st</sup> digit Position of decimal point: Not included in 5 digit data.

Ex) The 5 digit numeric data means

Ex.	Meaning of numerical data
Target temp., measured temp., and offset value	00010: 1.0 deg C
Operation mode	00000: RUN 00002: STOP (RDY)

⑥ ETX

The code necessary for the receiver to know the message is complete. It is put at the end of sent characters (except for BCC).

⑦ BCC

Exclusive OR (EX-OR) of all characters from STX to ETX are taken in. If BCC check is set to “no function” in the communication setting mode of the product, this code is not included in the “response message”.

⑧ ACK

The affirmation code included in the “response message” of the product; it is sent when the received “request message” contains no errors.

⑨ NAK

The negation code included in the “response message” of the product and sent with error type information (refer to “⑩ Error type”) when the received “request message” contains an error.

⑩ Error type

When the “request message” received by the product contains an error, the content of the error is included and sent subsequently to the “NAK” of the “response message”. If there are multiple errors, then the error that has been assigned the largest number is included and sent.

**Table 3-1 Content and classification of errors**

Error no.	Content of the error in a “request message”	
0	Memory error or controller failure	It replies regardless of the content of “request message”.
1	The numeric data is out of the “set range specified individually for each setting item”.	
2	There is no item with required.	
3	The numeric data is given an ASCII code other than the one for numeric data.  The position for the symbol is assigned an ASCII code other than “0” or “-”.	
4	Format error	
5	BCC error	
6	Overrun error	
7	Framing error	
8	Parity error	

## 3.6 Cautions for Communication

Pay attention to the following points for communication.

① Operation after the power supply is turned on

The product cannot communicate for approx. 6 sec. after the power supply is turned on. (No communication). Allow a time delay before starting communication after the power supply is turned on.

② Timing for sending and receiving

Allow a time delay for response to ensure the transition between sending from the master and receiving.

③ Requesting interval

When a "request message" is sent continuously from the master, allow an interval of 1ms or more after receiving the "response message" from the product.

④ Response requirements

The product will not send a "response message" if STX and ETX (BCC) are not included in the "request message". That is, if the "request message" contains an error, the "response message (to the error)", including NAK and ERR, is not sent. If the "response message" is not returned for a significant period after the "request message" is sent from the master, check the message and resend the necessary "request message".

⑤ Address designation error

When this error occurs, the product does not respond to a "request message" which specifies an address other than the set one. If the "response message" is not returned after a significant period, check the message and resend the necessary "request message".

⑥ Number of data digits and position of decimal point

Read or written data is expressed with 5 digits, regardless of its type. Refer to page 3-4 "3.5 Explanation of Code⑤".

⑦ Operation after "request message to store" is received

The product begins to store data after receiving a "request message to store" from the master. Only the data that has a different content from the EEPROM (data that has been changed) is stored. The time required for storage is approx. 6 sec. The product responds (sends an ACK) after the data storage is completed.

If the power supply is turned off during the storing process, the data might not be stored. Do not turn off the power supply before the storage completion message is received.

⑧ Storage of data other than the "request message to store"

When a parameter is changed with a key-in operation, the product stores all parameters into the EEPROM even if not receiving a "request message to store".



### 3.7 Communication Example

■ Communication example of request message to read

Request message from master: Request the product having a set address of 1 to read the measured temperature at that moment.



Response message from the product: Send the measured temperature (00250 =25.0 deg C) at that moment.

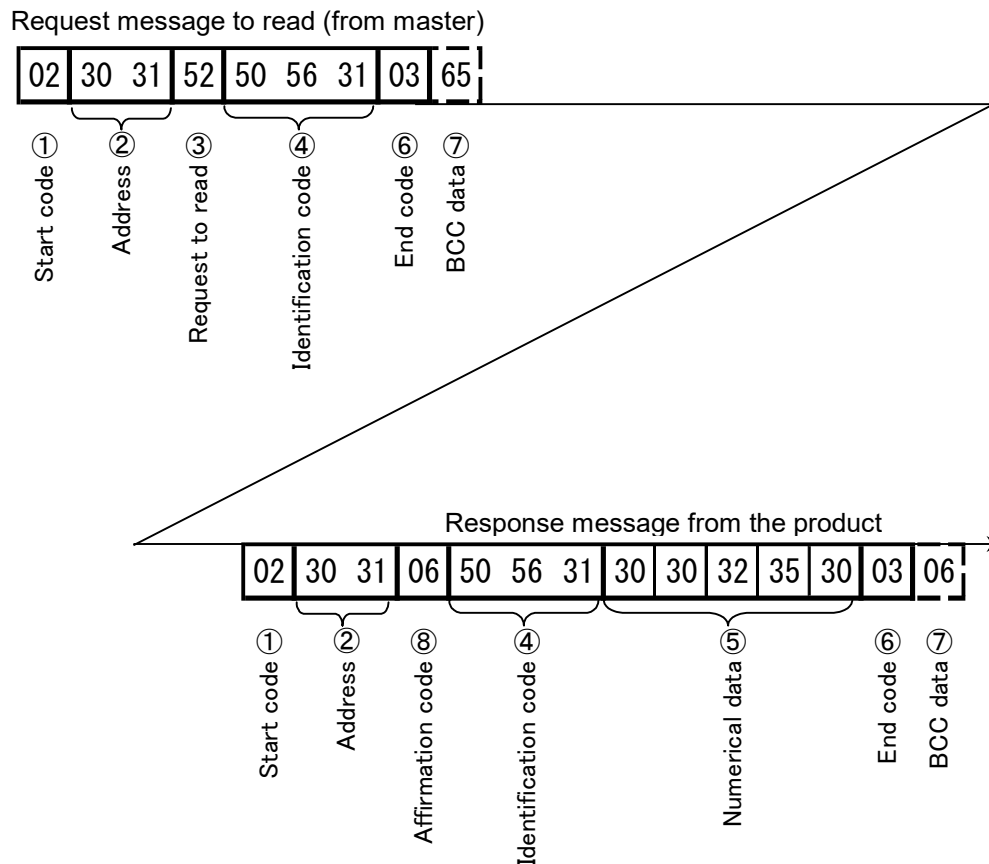

Code	Symbol/Data	ASCII code
① Start code	STX	02H
② Address	01	30H 31H
③ Required content	R (read)	52H
④ Identifier	PV1	50H 56H 31H
⑤ Numeric data	00250	30H 30H 32H 35H 30H
⑥ End code	ETX	03H
⑦ BCC data: Request		65H
	Response	06H
⑧ Acknowledge code	ACK	06H

■ Communication example of request message to write

Request message from master: Request the address having a set address of 10 to set the target temperature to 20.0 deg C.



Response message from the product: Notice it received the request message properly.

☆ Confirm whether or not data is written correctly by reading the data separately.

Request message to write (from master)

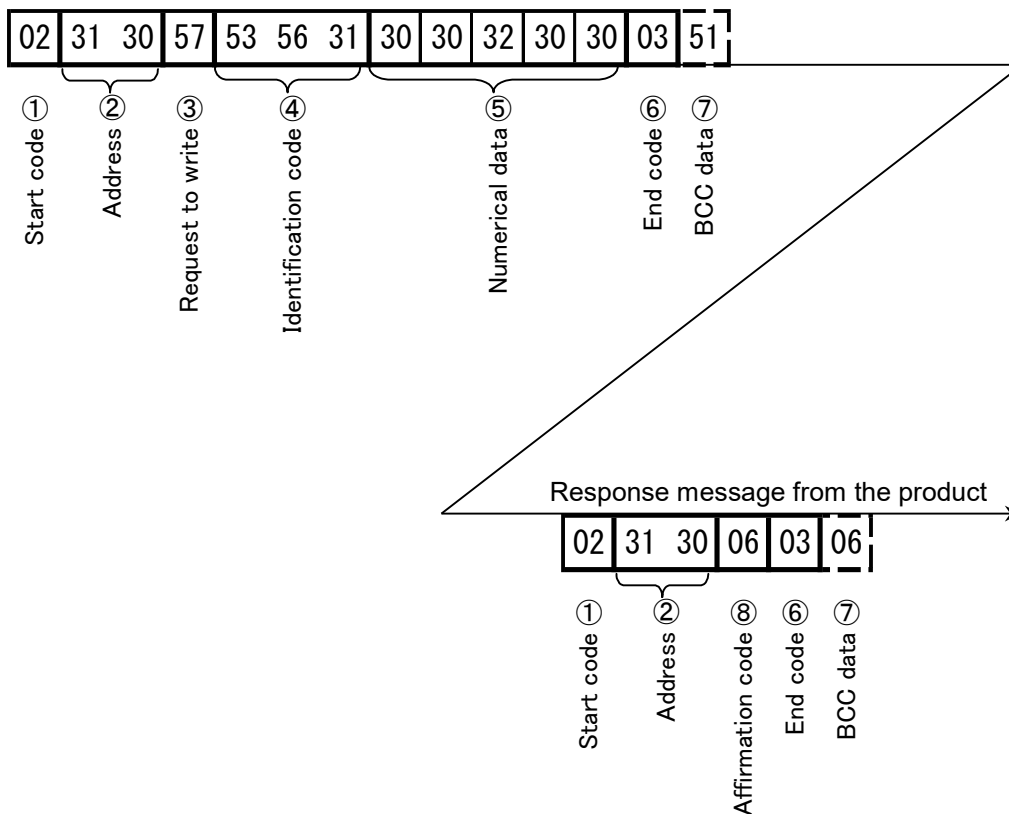

Code	Symbol/Data	ASCII code
① Start code	STX	02H
② Address	10	31H 30H
③ Required content	W (write)	57H
④ Identifier	SV1	53H 56H 31H
⑤ Numeric data	00200	30H 30H 32H 30H 30H
⑥ End code	ETX	03H
⑦ BCC data: Request		51H
Response		06H
⑧ Acknowledge code	ACK	06H

### 3.8 Connection (RS-485)

A terminal resistance needs to be mounted on the master and slave that are placed the furthest from each other. The resistance must be suitable for the characteristic impedance of the cables used for connection and have a combined resistance of 75 ohms or more.

### 3.9 Identification Code List

The following parameters can be changed.

**Table 3-2 List of identifiers (codes)**

Identifier	Description	R/W	Numerical data
PV1	Measured value (PV)	Read	-1999 to 05000
SV1	Set value (SV)	Read/Write	00100 to 00600
PVS	Offset setting	Read/Write	-0099 to 00099
STR	Data storage	Write	-
_MD <sup>note)</sup>	Operation mode	Read/Write	00000: RUN 00002: STOP (RDY)

Note) “\_” means 20H (space).

### 3.10 ASCII Code List

**Table 3-3 ASCII code**

ASCII code	02H	03H	06H	15H						
Code used	STX	ETX	ACK	NAK						
ASCII code	30H	31H	32H	33H	34H	35H	36H	37H	38H	39H
Number used	0	1	2	3	4	5	6	7	8	9
ASCII code	2DH	20H								
Number used	- Minus	SP Space								
ASCII code	41H	42H	43H	44H	45H	46H	47H	48H	49H	4AH
Character used	A	B	C	D	E	F	G	H	I	J
ASCII code	4BH	4CH	4DH	4EH	4FH	50H	51H	52H	53H	54H
Character used	K	L	M	N	O	P	Q	R	S	T
ASCII code	55H	56H	57H	58H	59H	5AH				
Character used	U	V	W	X	Y	Z				



## 4 Troubleshooting

The table below shows the solutions for the problems.

Problem	Cause	Solution
Communication cannot be made.	A wrong connecting cable is used.	Connect the host and the thermo-con with the following cables: A cross cable for RS-232C A straight cable for RS-485
	The settings of the host and thermo-con are not consistent with each others.	Make the following settings of the host and the thermo-con consistent: Address, Speed, Parity Check, Data Length, Stop Bit, BCC Check
	The program is incorrect.	Ensure that the program is made properly according to this operation manual. (Control code, command code, BCC check, etc.)
	The communication method is incorrect.	Use the communication method suitable for the specification of the thermo-con (RS-485, RS-232C).
	It is influenced by the noise from outside.	Use a shield wire for the cable, and ground the shield to the frame ground.
	It is influenced by the reflected wave.	Install a terminating resistance.
Communication cannot be continued.	The connecting cable comes off or broken.	Check the connecting cable.
The thermo-con does not give a correct answer.	The host sends more than one communication data successively.	When sending communication data, wait until an answer from the thermo-con is received to send the next data.



Revision history
------------------

# SMC Corporation

4-14-1, Sotokanda, Chiyoda-ku, Tokyo 101-0021 JAPAN

Tel: + 81 3 5207 8249 Fax: +81 3 5298 5362

URL <https://www.smcworld.com>

---

Note: Specifications are subject to change without prior notice and any obligation on the part of the manufacturer.  
© 2022 SMC Corporation All Rights Reserved