



# Operation Manual

PRODUCT NAME

*Standby Regulator*

MODEL / Series / Product Number

AR20S- (F, N) 02E-Y (Z) -15V (E)

AR30S- (F, N) 03E-Y (Z) -15V (E)

AR40S- (F, N) 04E-Y (Z) -15V (E)

AR50S- (F, N) 10E-Y (Z) -15V (E)

**SMC Corporation**

# Contents

	Page
1. Safety Instructions	2-9
<hr/>	
2. Application	10
<hr/>	
3. Standard Specifications	10
<hr/>	
4. How to Order	11
<hr/>	
5. Structural Drawing and Replacement Parts	12
<hr/>	
6. Operation and Adjustment	13-14
<hr/>	
7. Trouble Shooting	15
<hr/>	
8. How to Replace the Components	16-19
8-1. Diaphragm Assembly Replacement	16
8-2. Valve Guide Assembly and Valve Assembly Replacement	17
8-3. Square Embedded Type Pressure Gauge Replacement	18
8-4. Blanking Plate Assembly Replacement	19
<hr/>	
9. Disassembly Drawing	20-21
<hr/>	
10. Dimensions	22



# Safety Instructions

These safety instructions are intended to prevent hazardous situations and/or equipment damage. These instructions indicate the level of potential hazard with the labels of "Caution," "Warning" or "Danger." They are all important notes for safety and must be followed in addition to International Standards (ISO/IEC)\*1), and other safety regulations.

- \*1) ISO 4414: Pneumatic fluid power -- General rules relating to systems.
- ISO 4413: Hydraulic fluid power -- General rules relating to systems.
- IEC 60204-1: Safety of machinery -- Electrical equipment of machines .(Part 1: General requirements)
- ISO 10218: Manipulating industrial robots -Safety.
- etc.



## Caution

**Caution** indicates a hazard with a low level of risk which, if not avoided, could result in minor or moderate injury.



## Warning

**Warning** indicates a hazard with a medium level of risk which, if not avoided, could result in death or serious injury.



## Danger

**Danger** indicates a hazard with a high level of risk which, if not avoided, will result in death or serious injury.

## Warning

### **1. The compatibility of the product is the responsibility of the person who designs the equipment or decides its specifications.**

Since the product specified here is used under various operating conditions, its compatibility with specific equipment must be decided by the person who designs the equipment or decides its specifications based on necessary analysis and test results.

The expected performance and safety assurance of the equipment will be the responsibility of the person who has determined its compatibility with the product.

This person should also continuously review all specifications of the product referring to its latest catalog information, with a view to giving due consideration to any possibility of equipment failure when configuring the equipment.

### **2. Only personnel with appropriate training should operate machinery and equipment.**

The product specified here may become unsafe if handled incorrectly.

The assembly, operation and maintenance of machines or equipment including our products must be performed by an operator who is appropriately trained and experienced.

### **3. Do not service or attempt to remove product and machinery/equipment until safety is confirmed.**

1. The inspection and maintenance of machinery/equipment should only be performed after measures to prevent falling or runaway of the driven objects have been confirmed.

2. When the product is to be removed, confirm that the safety measures as mentioned above are implemented and the power from any appropriate source is cut, and read and understand the specific product precautions of all relevant products carefully.

3. Before machinery/equipment is restarted, take measures to prevent unexpected operation and malfunction.

### **4. Contact SMC beforehand and take special consideration of safety measures if the product is to be used in any of the following conditions.**

1. Conditions and environments outside of the given specifications, or use outdoors or in a place exposed to direct sunlight.

2. Installation on equipment in conjunction with atomic energy, railways, air navigation, space, shipping, vehicles, military, medical treatment, combustion and recreation, or equipment in contact with food and beverages, emergency stop circuits, clutch and brake circuits in press applications, safety equipment or other applications unsuitable for the standard specifications described in the product catalog.

3. An application which could have negative effects on people, property, or animals requiring special safety analysis.

4. Use in an interlock circuit, which requires the provision of double interlock for possible failure by using a mechanical protective function, and periodical checks to confirm proper operation.



# Safety Instructions

## **Caution**

### **The product is provided for use in manufacturing industries.**

The product herein described is basically provided for peaceful use in manufacturing industries.

If considering using the product in other industries, consult SMC beforehand and exchange specifications or a contract if necessary.

If anything is unclear, contact your nearest sales branch.

## **Limited warranty and Disclaimer/Compliance Requirements**

The product used is subject to the following “Limited warranty and Disclaimer” and “Compliance Requirements”.

Read and accept them before using the product.

### **Limited warranty and Disclaimer**

1. The warranty period of the product is 1 year in service or 1.5 years after the product is delivered, whichever is first.\*2)

Also, the product may have specified durability, running distance or replacement parts. Please consult your nearest sales branch.

2. For any failure or damage reported within the warranty period which is clearly our responsibility, a replacement product or necessary parts will be provided.

This limited warranty applies only to our product independently, and not to any other damage incurred due to the failure of the product.

3. Prior to using SMC products, please read and understand the warranty terms and disclaimers noted in the specified catalog for the particular products.

\*2) Vacuum pads are excluded from this 1 year warranty.

A vacuum pad is a consumable part, so it is warranted for a year after it is delivered.

Also, even within the warranty period, the wear of a product due to the use of the vacuum pad or failure due to the deterioration of rubber material are not covered by the limited warranty.

### **Compliance Requirements**

1. The use of SMC products with production equipment for the manufacture of weapons of mass destruction(WMD) or any other weapon is strictly prohibited.

2. The exports of SMC products or technology from one country to another are governed by the relevant security laws and regulation of the countries involved in the transaction. Prior to the shipment of a SMC product to another country, assure that all local rules governing that export are known and followed.

## **Caution**

### **SMC products are not intended for use as instruments for legal metrology.**

Measurement instruments that SMC manufactures or sells have not been qualified by type approval tests relevant to the metrology (measurement) laws of each country.

Therefore, SMC products cannot be used for business or certification ordained by the metrology (measurement) laws of each country.

## Design

### Warning

1. Provide ventilation when using a valve in a confined area, such as in a closed control panel. For example, install a ventilation opening etc. in order to prevent pressure from increasing inside of the confined area and to release the heat generated by the valve.
2. Polyacetal resin parts are used for the exterior. Organic solvents including thinner, acetone, alcohol and ethylene chloride; chemicals including sulphuric acid, nitric acid and hydrochloric acid; cutting oil, synthetic oils, ester-based compressor oil, alkali, kerosene, gasoline, lock material of screw are harmful. Do not use the product where these are present.
3. Consult SMC if no leakage is allowed due to the environment, or if the operating fluid is not air.
4. Shield from ultra violet light and radiation with protective cover.
5. A safety device needs to be installed if output pressure is exceeding the set pressure, otherwise this can cause breakage of outlet device and equipment or lead to malfunction.

## Selection

### Warning

1. The products presented in this catalog are designed only for use in compressed air systems. Do not operate at pressures, temperatures, etc., beyond the range of the specifications, as this can cause damage or malfunction. (Refer to the specifications.) Please contact SMC is using for other fluids than compressed air.
2. Grease used on the internal sliding parts and seals may flow to the outlet side. If this is not acceptable, please consult SMC.
3. Long absence of operation or operation with sealed circuit or balancing circuit on the outlet side may cause set pressure fluctuation. Please consult SMC if this is not acceptable.
4. Set range of outlet pressure shall be 85% or less of the inlet pressure. Operating at a setting exceeding 85% causes the outlet pressure to be easily affected by fluctuations in flow rate and inlet pressure, leading to instability.
5. Since the safety margin is calculated to the maximum value of the set pressure range shown in the specification table, the pressure setting may be over the maximum value. However, use the product within the specified range.
6. If the product is used with circuit which requires high exhaust sensitivity or set precision, please consult SMC.

### Caution

1. Particularly when using a C-R element (surge voltage suppressor) to protect the switching element, take note that leakage current will flow through the C-R element, thus increasing leakage voltage

AC coil is 8% or less of the rated voltage.  
DC coil is 3% or less of the rated voltage.

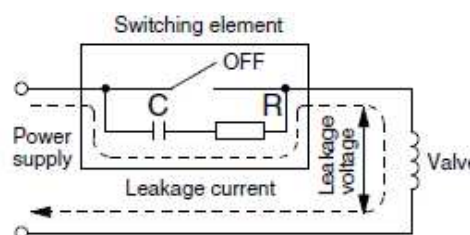

2. Although the valve can be operated at temperature as low as 0 °C, measure should be taken 0 °C to avoid solidifying or freezing drainage and moisture, etc.

## Mounting

### Warning

1. Mount and operate the product after reading the manual carefully and understanding its contents. Also, keep the manual in a place where it can be referred to as necessary.
2. Install with enough space around the regulator to perform regular maintenance and operation. Refer to section [10.Dimensions] (p. 22) for necessary space.
3. Do not drop or apply impact during transportation or installation. Damage of products or pressure gauge can result in malfunction.
4. Do not install in areas with high humidity or high temperature. It may lead to a malfunction of the pressure gauge.
5. If air leakage increases or equipment does not operate properly, stop operation. After mounting or maintenance, etc., connect the compressed air and power supplies, and perform appropriate function and leakage tests to confirm that the unit is mounted properly.

## Adjustment

### Warning

1. Adjust the set pressure ensuring correct inlet and outlet pressures. Turning the knob excessively can cause damage to the internal parts.
2. Do not use tools on the pressure regulator knob as this may cause damage. It must be operated manually.

### Caution

3. For the product with a pressure gauge, do not apply pressure exceeding the maximum scale of the pressure gauge in order to protect the gauge.
4. When setting the pressure, the inlet pressure must be supplied after the pilot valve is powered.
5. Adjust the pressure whilst the pressure is increasing. Pressure may become lower than the set pressure if adjusted by decreasing the value. Rotate the knob clockwise to increase the set pressure. Counterclockwise to decrease the pressure. Moreover, please lock the knob after setting pressure.
6. For the regulator with backflow function, upstream pressure needs to be higher than downstream pressure by 0.05 MPa or more.
7. Outlet pressure may rise when the inlet pressure is discharged and resupplied after pressure setting. In this case, consume air at the outlet which will bring the pressure closer to the set pressure.
8. Outlet pressure may change if the product is used for a long period of time. Please confirm the set pressure regularly.
9. When pressure difference between the inlet side and the outlet side is large, chattering may occur. In that case, please reduce the pressure difference between the inlet and the outlet. Please consult SMC if chattering continues.

## Mounting

### Warning

1. Before piping is connected, it should be thoroughly blown out with air (flushing) or washed to remove chips, cutting oil and solid foreign material from inside the pipe. Contamination of piping may cause damage or malfunction.
2. When screwing together pipes and fittings, etc., be certain that chips from the pipe threads and sealant do not get inside the pipe. When a sealant tape is used, leave 1.5 to 2 thread ridges exposed at the end of the threads.
3. Connect piping/fittings using the recommended torque while holding the female thread side tightly. Insufficient tightening torque leads to cause of loosening or sealing failure, and excessive tightening torque leads to cause of breakage of screws. Tightening without holding female thread applies an excessive force to the piping bracket directly, leading to breakage.

Recommended tightening torque for the port						Unit: N m
Thread size	1/8	1/4	3/8	1/2	3/4	1
Torque	7 to 9	12 to 14	22 to 24	28 to 30	28 to 30	36 to 38

4. Before using an SMC fitting and S coupler, please refer to "Tightening the threaded portion of the connection thread" of the Fittings & Tubing Precautions.
5. Do not apply torsion or bending moment other than the weight of the product itself. External piping needs to be supported separately as it may cause breakage. Non-flexible piping like steel tube is susceptible to excessive moment load or vibration. Insert flexible tubes to prevent this.
6. When connecting to modular connection-compatible equipment, select either spacers with brackets or spacers.

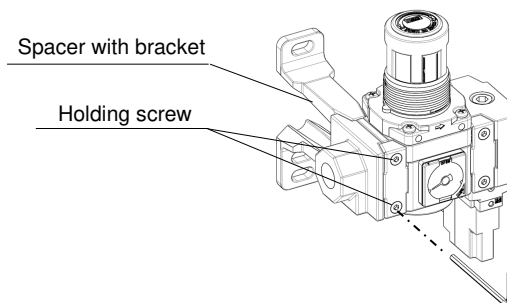

Tighten the 2 holding screws on the spacer with bracket or spacer evenly. Tighten them to the recommended tightening torque. Insufficient tightening torque may result in loosening or sealing failure. Excessive tightening torque may damage the thread, etc.

Recommended tightening torque for spacer and spacer with bracket					Unit: N m
Model	AR20S	AR30S	AR40S	AR50S	
Spacer with bracket	Y200T-2-D	Y300T-2-D	Y400T-1-D	Y600T-2-D	
Spacer	Y200-D	Y300-D	Y400-D	Y600-D	
Torque	0.36±0.036	1.2±0.05	1.2±0.05	2.0±0.1	

7. There are no piping threads on the OUT port of this product.

## Wiring

### **Warning**

1. When electric power is connected to a solenoid valve, be careful to apply the proper voltage. Improper voltage may cause malfunction or coil damage.
2. Excessive force applied to the cable connector may cause disconnection. Do not apply repetitive bending, tensile, or heavy loads to the cable.
3. Tighten the connector with hand. Use of tools may damage the connectors.
4. Do not unnecessarily pull on connectors or cables.

## Air Source

### **Warning**

1. Use clean air. Do not use compressed air containing chemicals, organic solvent, synthetic oil or corrosive gas as it may be cause of breakage of components or operation failure.
2. Air containing too much moisture may cause malfunction. Install an air drier or aftercooler before the regulator.

### **Caution**

1. Install an air filter at the upstream side of this product. Select an air filter with a filtration degree of 5µm or finer.
2. If an excessive amount of carbon powder is present, install a mist separator on the upstream side. If excessive carbon dust is generated by the compressor, it may adhere to the inside of this product and cause it to malfunction.

Refer to SMC's "Air Cleaning Equipment" catalog for further details on compressed air quality.

## Operating Environment

### **Warning**

1. Do not use in atmospheres contacting corrosive gases, chemicals, sea water, water, water steam, or where there is direct contact with any of these.
2. Do not use in explosive atmosphere.
3. Do not use in locations subject to vibration or impact.
4. Do not expose to direct sunlight for an extended period of time. Protective cover should be used to shield.
5. Do not mound in locations where is nearby heat source. Radiated heat should be also prevented.
6. Implement suitable protective measures in locations where there is contact with water droplets, oil, or welding spatter.
7. Install a silencer into exhaust port to prevent the dust ingress if there is a lot of dust in atmosphere, as dust may cause air leakage.



## Maintenance

### Warning

1. Release the pressure in the product to the atmosphere when replacing parts or removing piping.
2. Maintenance and checks should be done by following the procedure in this operation manual. Incorrect handling of the product may cause breakage or operation failure of the equipment or device.
3. Valves should be switched at least once every 30 days to prevent a malfunction. (Use caution regarding the air supply.)

### Caution

1. If an emergency countermeasure is to be taken during setting failure or exhaust leakage, the internal valve seating part should be checked. If failure such as foreign matter is found, remove it before performing the emergency countermeasure.

## Maintenance

### Warning

1. Operate the manual override when switching pressure on the outlet side regardless of the electrical signal from the pilot valve. Operating the manual override while there is air consumption at the outlet side will reduce the pressure at the outlet side. Make sure there is no danger before operating the manual override.

#### ■ Non-locking push type

While pressing, turn it the direction of the arrow.

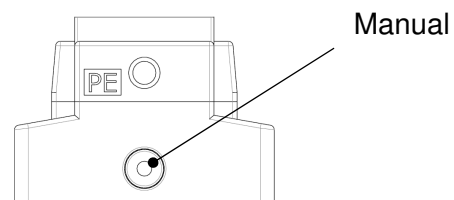
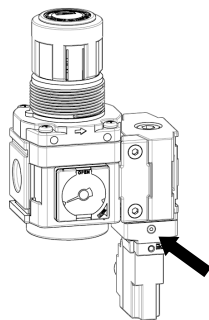

#### ■ Push-turn locking lever type

While pressing, turn it the direction of the arrow.

If it is not turned, it can be operated the same way as the non-locking type.

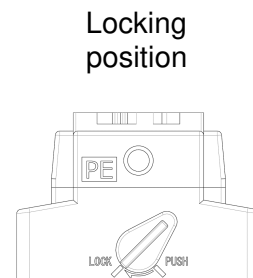
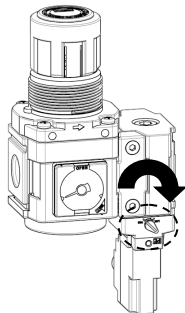

### Caution

When locking the manual override on the push-turn locking lever type, be sure to push it down before turning.

Turning without first pushing it down can cause damage to the manual override and trouble such as air leakage etc.

## Maintenance



### Caution

<For DC>

### M12 Connector

With light/surge voltage suppressor (WOZ)

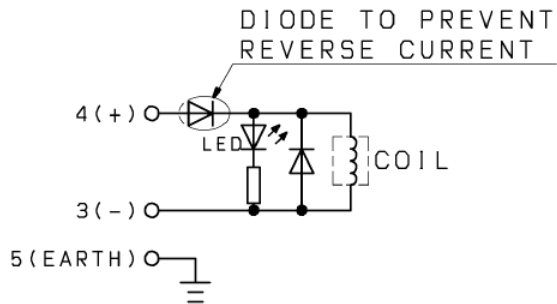

- Connect correctly the lead wires to + (positive) and – (negative) indications on the connector.

### Solenoid valve side pin wiring diagram

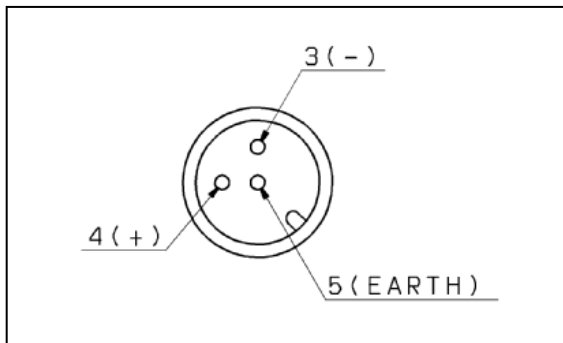

## 2. Application

This unit is capable of switching between operating pressure, when the pneumatic system is in operation, and low-pressure air when the system is idle. It is intended to reduce air consumption in facilities.

## 3. Standard Specifications

Model	AR20S	AR30S	AR40S	AR50S
Port size	1/4	3/8	1/2	1
Fluid	Air			
Ambient and fluid temperature <sup>Note 2)</sup>	0 to 50°C (No freezing)			
Proof pressure	1.05 MPa			
Max. operating pressure	0.7 MPa			
Set pressure range	0.20 to 0.40 MPa			
Construction	Non-relieving type			
Pilot exhaust type	Individual exhaust			
Lubrication	Not required			
Impact/Vibration resistance <sup>Note1)</sup>	150/30m/s <sup>2</sup>			
Enclosure	IP65 (Only electrical equipment part)			
Weight	0.30kg	0.49kg	0.77kg	1.49kg

Note ) Impact resistance: No malfunction occurred when it is tested in the axial direction and at the right angles to the main valve and armature in both energized and de-energized states every once for each condition. (Values at the initial period)

Vibration resistance: No malfunction occurred in a one-sweep test between 45 and 2,000 Hz.

Test was performed at both energized and de-energized states in the axial direction and at the right angles to the main valve and armature.(Values at the initial period)

## 4. How to Order

AR **30** S - **F** **03** E - Y **4** - 15V **5**

①
②
③
④
⑤

		Symbol		Description		①			
						Body size			
						20	30	40	50
②	Thread type	Nil		Rc		•	•	•	•
		N		N P T		•	•	•	•
		F		G		•	•	•	•
				+					
③	Port size (Only IN port)	0 2		1 / 4		•	-	-	-
		0 3		3 / 8		-	•	-	-
		0 4		1 / 2		-	-	•	-
		1 0		1		-	-	-	•
				+					
	Pressure gauge	E		Square embedded type pressure gauge (with limit indicator)		•	•	•	•
				+					
	Knob	Y		Upward		•	•	•	•
				+					
④	Unit indication	Nil		Unit on product label: MPa, Pressure gauge in SI units: MPa		•	•	•	•
		Z		Unit on product label: MPa Unit on Pressure gauge: MPa/psi dual scale		•	•	•	•
				+					
	Pilot valve mounting position and wiring direction	1		Mounting position : Opposite of knob Wiring direction : Back side		•	•	•	•
				+					
	Coil rated voltage	5		DC24V		•	•	•	•
				+					
	Electrical entry	V		M12 Connector		•	•	•	•
				+					
	Light/surge voltage suppressor	Nil		With light/surge voltage suppressor		•	•	•	•
				+					
⑤	Manual override	Nil		Non-locking push type		•	•	•	•
		E		Push-turn locking type		•	•	•	•

## 5. Structural Drawing and Replacement Parts

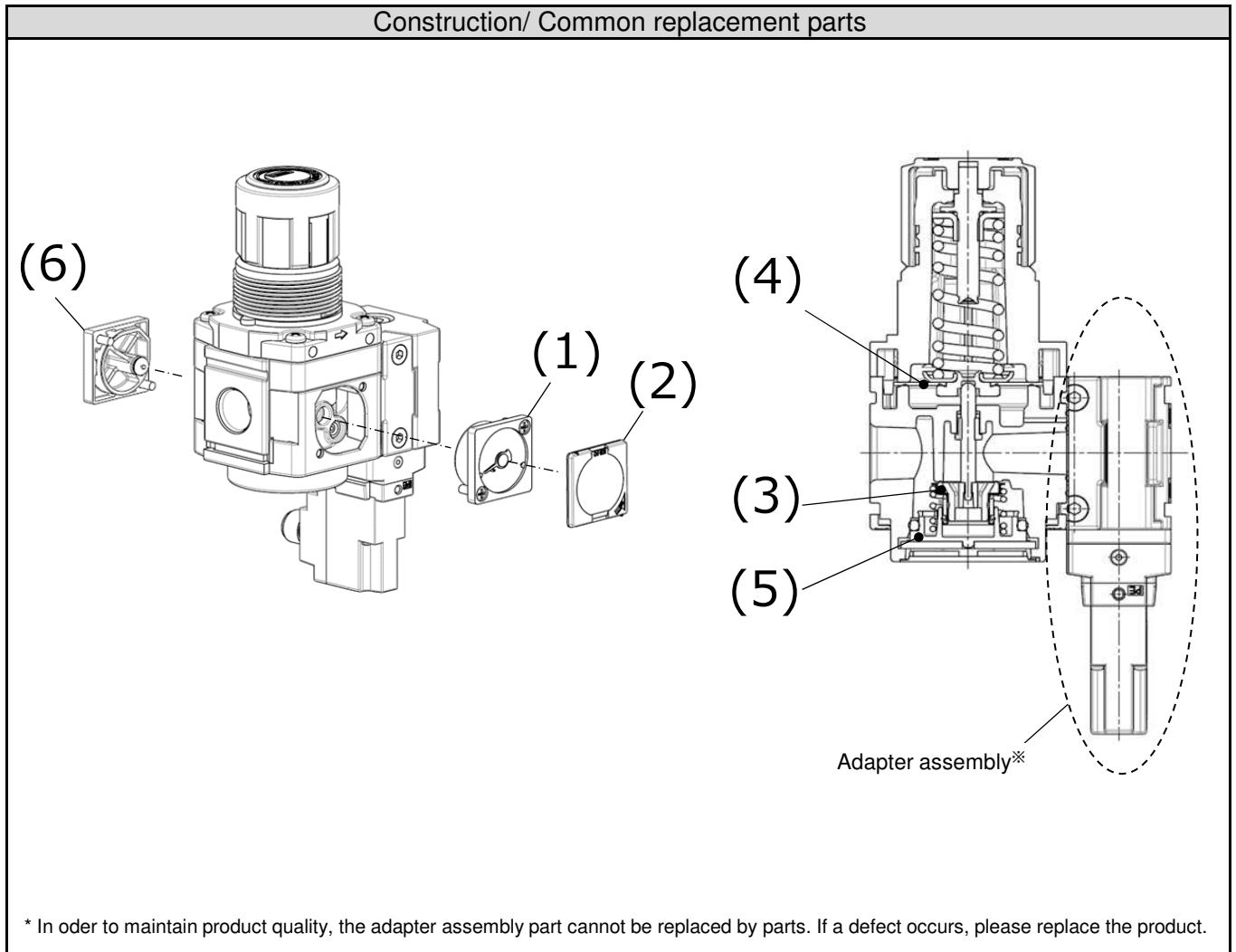

### Replacement parts

No.	Part name	Semi-standard specification	Part No.			
			AR20S	AR30S	AR40S	AR50S
(1)	Square embedded type pressure gauge <sup>Note 1)</sup> (Including part (2))	-	GC3-10AS-D			
		Z: Both in MPa and psi	GC3-P10AS-D-X30			
(2)	Pressure gauge cover assembly	-	136150A			
(3)	Valve assembly		AR24KP-660AS	AR34KP-660AS	AR44KP-660AS	AR54P-660AS
(4)	Diaphragm assembly		AR24P-150AS-N	AR34P-150AS-N	AR44P-150AS-N	AR54P-150AS-N
(5)	Valve guide assembly		AR24P-050AS	AR34P-050AS	AR44P-050AS	AR64P-050AS
(6)	Blanking plate assembly		AR24P-250AS			

Note) The numbers in the table and structural drawings are consistent with the numbers in sections [8. How to Replace the Components] (P16-19) and [9. Disassembly Drawing] (P20-21).

Note 1) With O-ring (1 pc.) and mounting screws (2 pcs.).

## 6. Operation and Adjustment

### 6-1. Pressure regulation

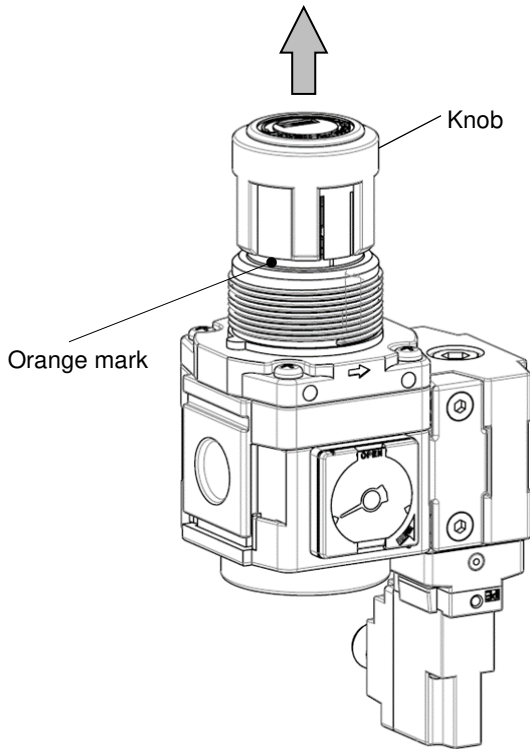

- (1) Pull the knob in the arrow direction for unlocking, revealing an orange mark.

\* Make sure the handle is fully loosened before moving on to step (2).

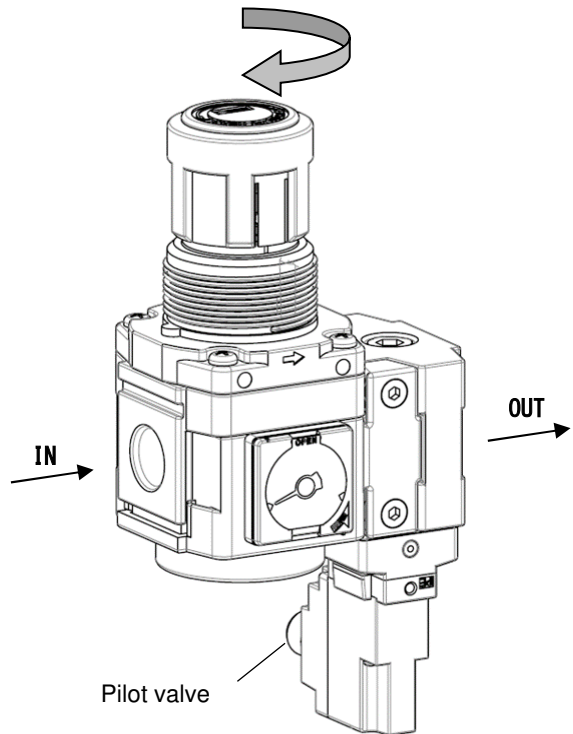

- (2) Turn on the power to the pilot valve and supply pressure to the IN side of the product. Then, turning the handle clockwise in the unlocked state increases the pressure on the outlet side. Note) Always set the pressure in the upward direction (arrow direction). Otherwise, it may cause insufficient set pressure.

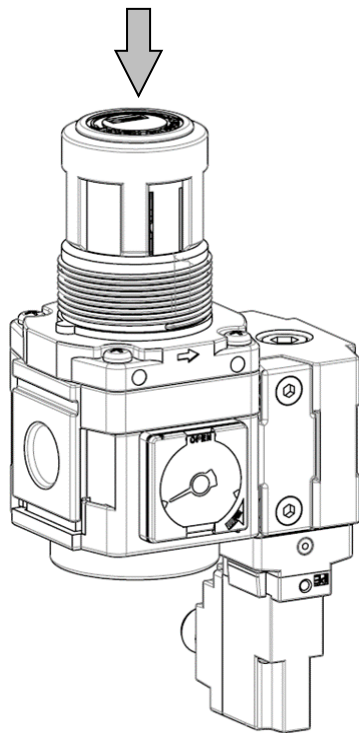

- (3) After adjusting pressure, lock the knob by pushing it in the arrow direction.

\* The state shown in (3), with the pilot valve turned on, is called "standby mode".

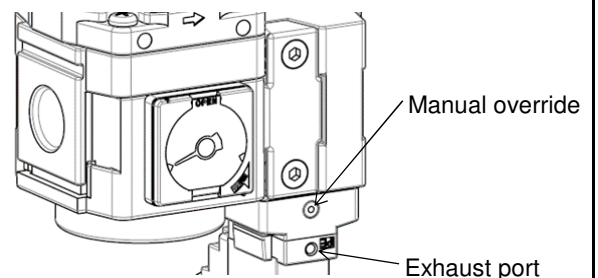

- (4) When the power to the pilot valve is turned off in the state (3), some air is exhausted from the exhaust port and the pressure at the outlet side becomes the same as the supply pressure.

\* The state shown in (4) is called "operation mode". With air consumption downstream of the product, it is possible to switch to each mode by switching the pilot valve ON/OFF or by operating the manual override.

- Operation mode  
→ When solenoid valve is OFF or the manual override is not operated.
- Standby mode  
→ When solenoid valve is turned on or the manual override is operated.

## 6. Operation and Adjustment

### 6-2. Indicator adjustment of the square embedded type pressure gauge

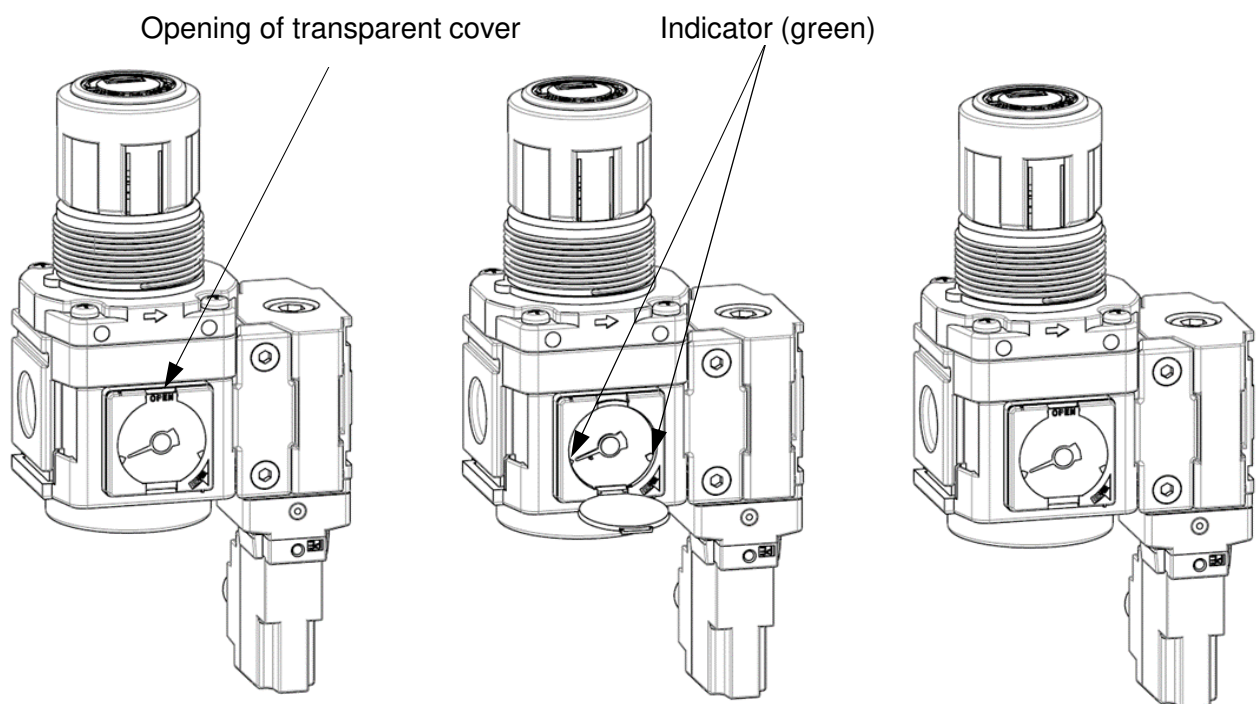

(1) Pull the opening of the transparent cover to unlock.

(2) Open the transparent cover as in the drawing and adjust the indicator to the upper and lower limit positions to be controlled.

(3) Close the transparent cover after adjusting the indicator.

## 7. Trouble Shooting

Refer to sections [8. How to Replace the Components] (P16-19) and [9. Disassembly Drawing] (P20-21).

Trouble		Possible cause	Countermeasure	Page for reference
Category	Failure			
Pressure	The pressure can not be adjusted.	1. Air pressure is not supplied to the inlet.	Check the supply pressure. Ensure that the supply side ball valve is opened.	—
		2. The product is installed opposite to the flow direction.	Install the product correctly after confirming the direction of flow. "1" indicates the IN and "2" indicates the OUT.	—
		3. Pressure regulating spring is damaged.	Replace the pressure regulating spring.	P16
		4. Valve spring is damaged.	Replace the valve spring.	P17
		5. Foreign materials caught in the rubber seat of the valve or the check valve seal.	Replace the valve guide assembly and valve assembly.	P17
		6. Seating part of the valve is damaged.	Replace the valve assembly.	P17
		7. Power is not supplied to the pilot valve.	Confirm that the power supply to the pilot valve is correctly connected.	—
		8. With the pilot valve in the OFF state, the setting was started by turning the handle.	When setting pressure, follow the pressure adjustment method.	P13
	Outlet pressure cannot be set even after switching the pilot valve from OFF to ON.	1. With the pilot valve in the OFF state, the setting was started by turning the handle.	Vent the pressure once, loosen the handle completely, and then set it again according to the pressure adjustment method.	P13
	The outlet pressure remains reduced even after switching the pilot valve ON/OFF.	1. The manual override is in the ON state.	Make sure the manual override is in the OFF state.	P13
	Even if the pilot valve is switched ON/OFF, the pressure is not reduced to the set pressure.	1. No air consumption downstream of the product.	If there is no air consumption downstream of the product, the pressure cannot be reduced to the set pressure. Switch the pilot valve with air consumption.	P13
Air leakage	Air leaks from the bonnet exhaust port.	1. Diaphragm is damaged.	Replace the diaphragm assembly.	P16
	Air leaks from between the bonnet and the body.	1. Loosened bonnet screws.	Fasten the bonnet.	P16
		2. Diaphragm is damaged.	Replace the diaphragm assembly.	P16
Backward flow	Air does not flow backwards.	1. Foreign matter caught in the check valve seal leads to malfunction. Or, the check valve seal is stuck.	Clean the check valve seal and add grease. If the condition is not improved, replace the valve guide assembly and check valve assembly.	P17

Note) Fluorine grease is recommended when applying additional grease.



## 8. How to Replace the Components

### Warning

Before replacement, make sure that no pressure remains in the equipment.  
Also, make sure to loosen the knob of the regulator so that the set pressure is zero.

After replacement, confirm that the product satisfies specific functions and no external leakage occurs before operating it.

### 8-1. Diaphragm Assembly Replacement

Applicable model	Work category	Procedure	Tool	Criteria						
AR20S AR30S AR40S AR50S	Disassembly	1) Loosen the knob completely before disassembly.	—	—						
		2) Remove the 4 screws and remove the bonnet.	AR20S/ AR30S / AR40S Phillips screwdriver  AR50S Hexagon wrench Nominal size: 5	—						
		3) Remove the pressure regulating screw assembly, pressure regulating spring, and diaphragm assembly in that order.	—	—						
	Assembly	4) Assemble the diaphragm assembly, pressure regulating spring, and then pressure regulating screw assembly.	—	Direction of diaphragm assembly and pressure regulating screw assembly						
		5) Assemble the bonnet to the body. While the convex side of the bonnet is facing the IN side, mount it onto the body. Then tighten the 4 mounting screws temporarily, before tightening them diagonally and evenly to fix the bonnet.	AR20S/ AR30S / AR40S Phillips screwdriver  AR50S Hexagon wrench Nominal size: 5	Tightening torque: <table border="1"> <tr> <td>AR20S</td> <td>2.35±0.3N · m</td> </tr> <tr> <td>AR30S</td> <td></td> </tr> <tr> <td>AR40S</td> <td>3.5 ±0.3N · m</td> </tr> <tr> <td>AR50S</td> <td></td> </tr> </table>	AR20S	2.35±0.3N · m	AR30S		AR40S	3.5 ±0.3N · m
AR20S	2.35±0.3N · m									
AR30S										
AR40S	3.5 ±0.3N · m									
AR50S										

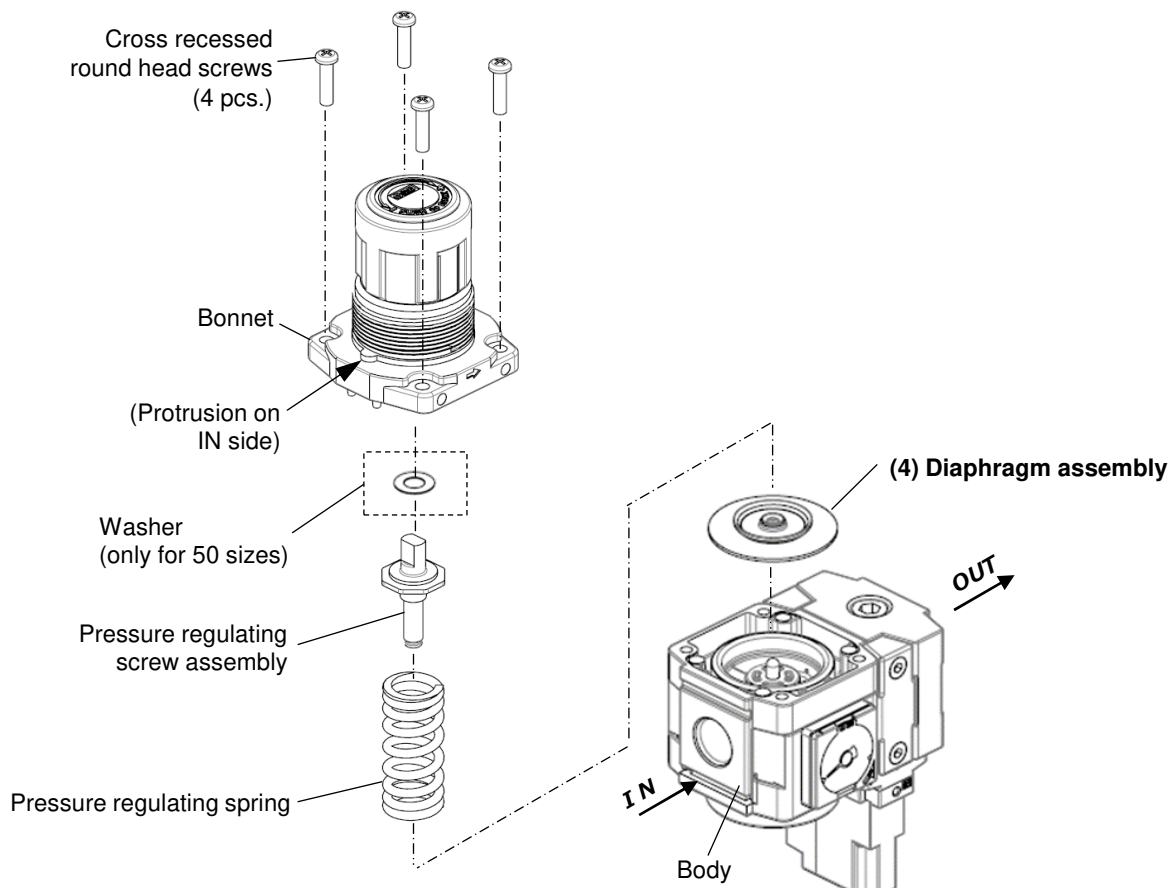

## 8-2. Valve Guide Assembly and Valve Assembly Replacement

Applicable model	Work category	Procedure	Tool	Criteria
AR20S AR30S AR40S AR50S	Disassembly	1) Remove the cap. Insert a precision screwdriver (-) between the body and cap to lift the cap.	Precision screwdriver (-)	—
		2) Remove the cover. Insert round pliers into the small holes of the cover and rotate 45 degree to the left or right, then lift the cover to remove.	Round pliers Nominal: 125	—
		3) Remove the valve guide assembly. Remove it while lifting the circumferential part with a precision screwdriver.	Precision screwdriver (-)	—
		4) Remove the valve spring.	—	—
		5) Remove the valve assembly.	—	—
	Assembly	6) After replacing the removed components with new components, place them into the regulator. Assemble the components in reverse order to the removal procedure.	—	(See below for the mounting direction of the components.)

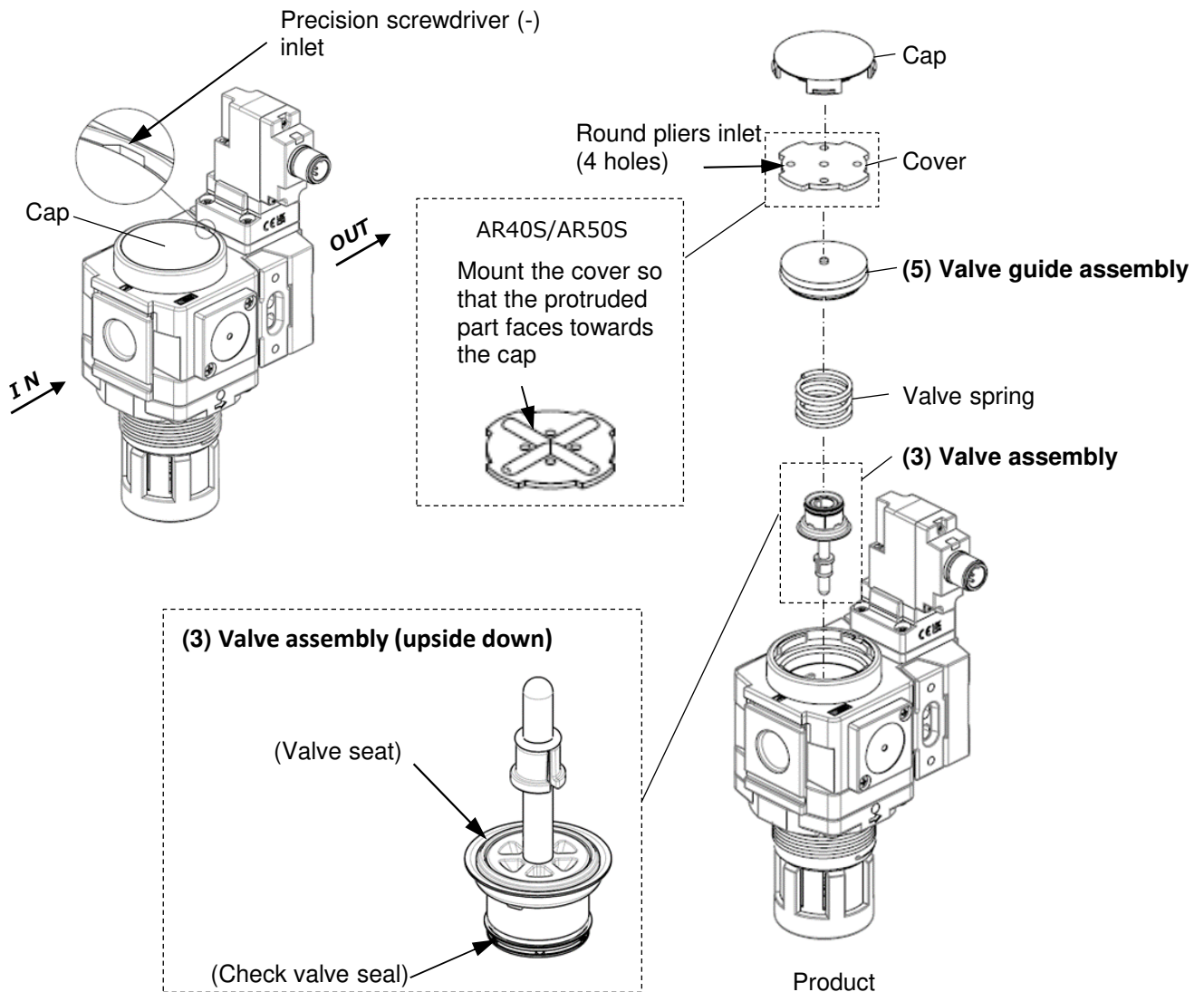

### 8-3. Square Embedded Type Pressure Gauge Replacement

Applicable model	Work category	Procedure	Tool	Criteria
AR20S AR30S AR40S AR50S	Disassembly	1) Remove the pressure gauge cover. Rotate the pressure gauge cover 15 degrees in the arrow direction (counterclockwise) and pull it out.	—	—
		2) Remove the pressure gauge. Remove the 2 mounting screws and remove the pressure gauge.	Phillips screwdriver	—
	Assembly	3) Confirm that the O-ring is mounted onto the pressure gauge. When the O-ring comes out or is left on the regulator, mount the O-ring to the pressure gauge correctly.	—	Presence of the O-ring
		4) Mount the pressure gauge. Mount the pressure gauge to the regulator with the mounting screws and tighten the screws referring to the tightening torque specified in the right column.	Phillips screwdriver	Tightening torque: 0.85+/-0.05 N m
		5) Mount the pressure gauge cover. Set the pressure gauge cover with its arrow on the lower right corner. Mate the 2 fingers of the pressure gauge cover with the 2 finger slits of the pressure gauge, and rotate the pressure gauge cover 15 degrees to the opposite direction of the arrow (clockwise).	—	—

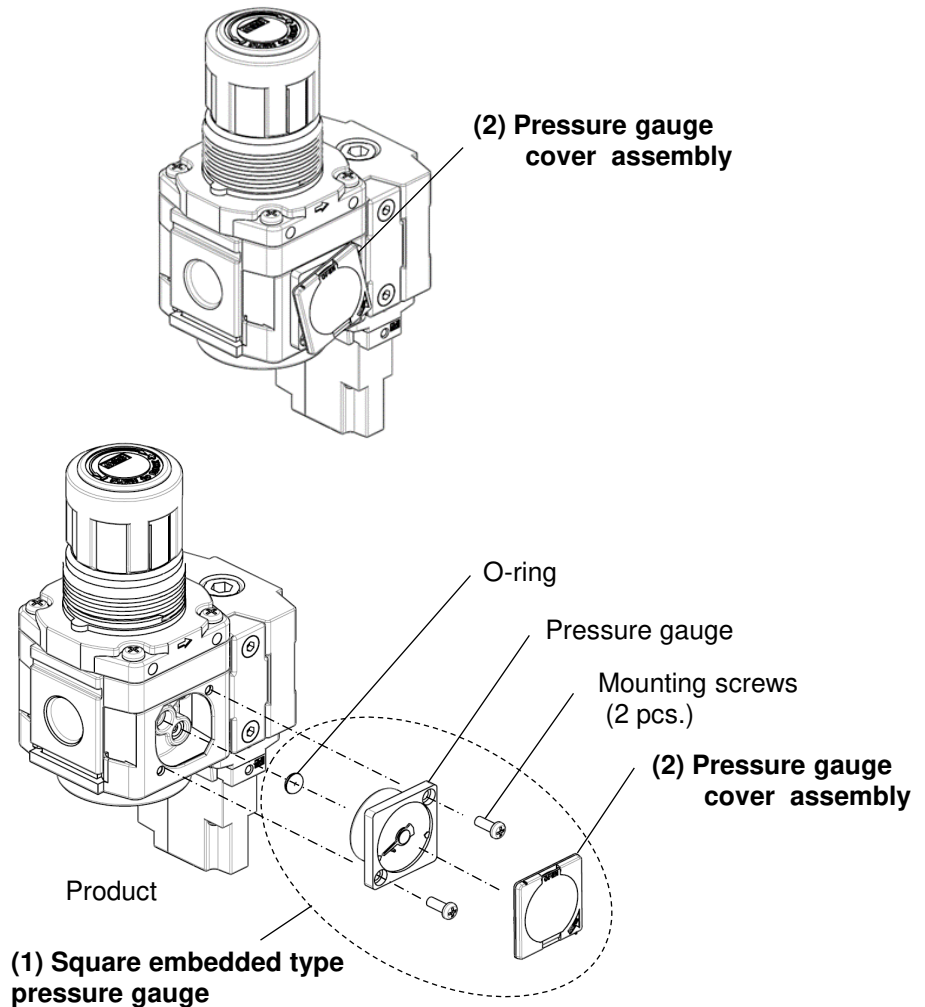

### 8-4. Blanking Plate Assembly Replacement

Applicable model	Work category	Procedure	Tool	Criteria
AR20S AR30S AR40S AR50S	Disassembly	1) Remove the blanking plate. Remove the 2 mounting screws and remove the blanking plate.	Phillips screwdriver	—
	Assembly	2) Confirm that the O-ring is mounted onto the blanking plate. When the O-ring comes out or is left on the regulator, mount the O-ring to the blanking plate correctly.	—	Presence of the O-ring
		3) Mount the blanking plate. Mount the blanking plate to the product with the mounting screws and tighten the screws referring to the tightening torque specified in the right column.	Phillips screwdriver	Tightening torque: 0.6+/-0.05 N m

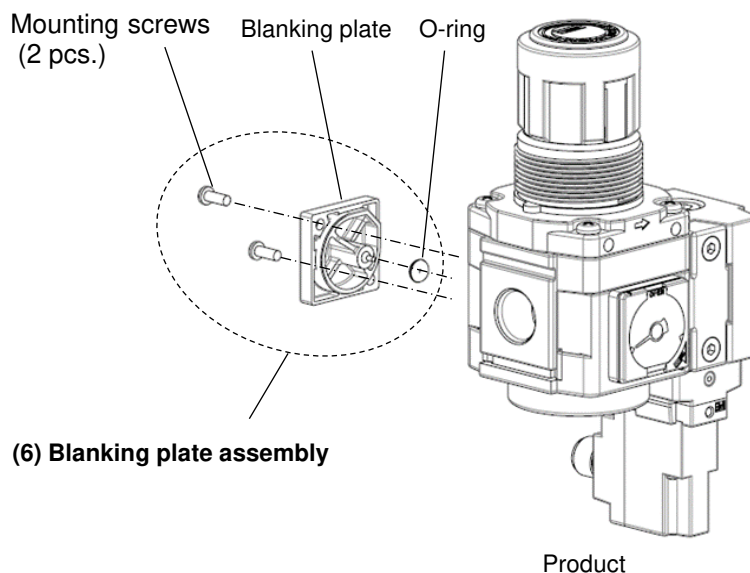

# 9. Disassembly Drawing

9-1. AR20S / AR30S / AR40S / AR50S Dissassembly Drawing of part

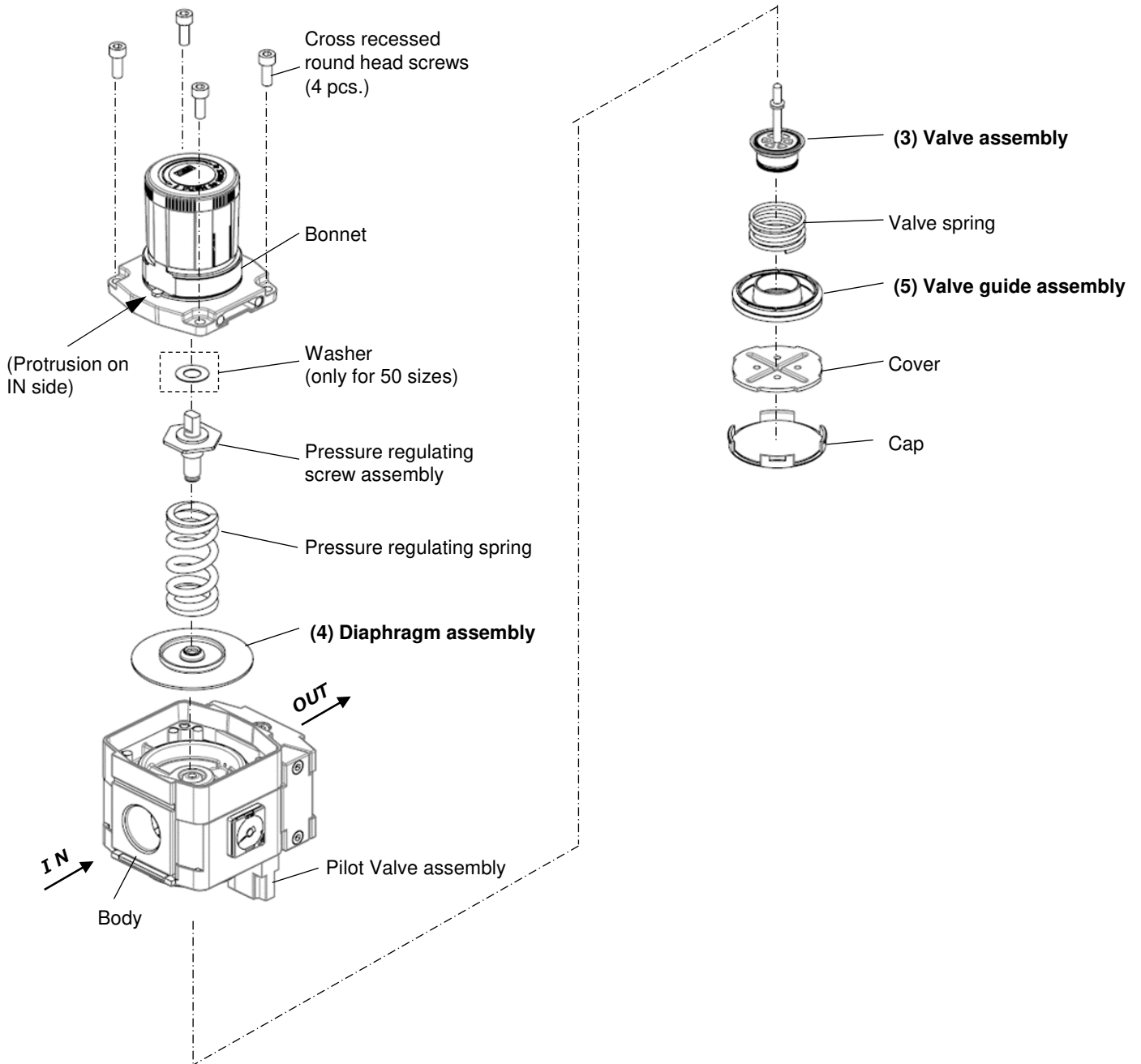

## 9-2. Disassembly Drawing of the Pressure Gauge Port

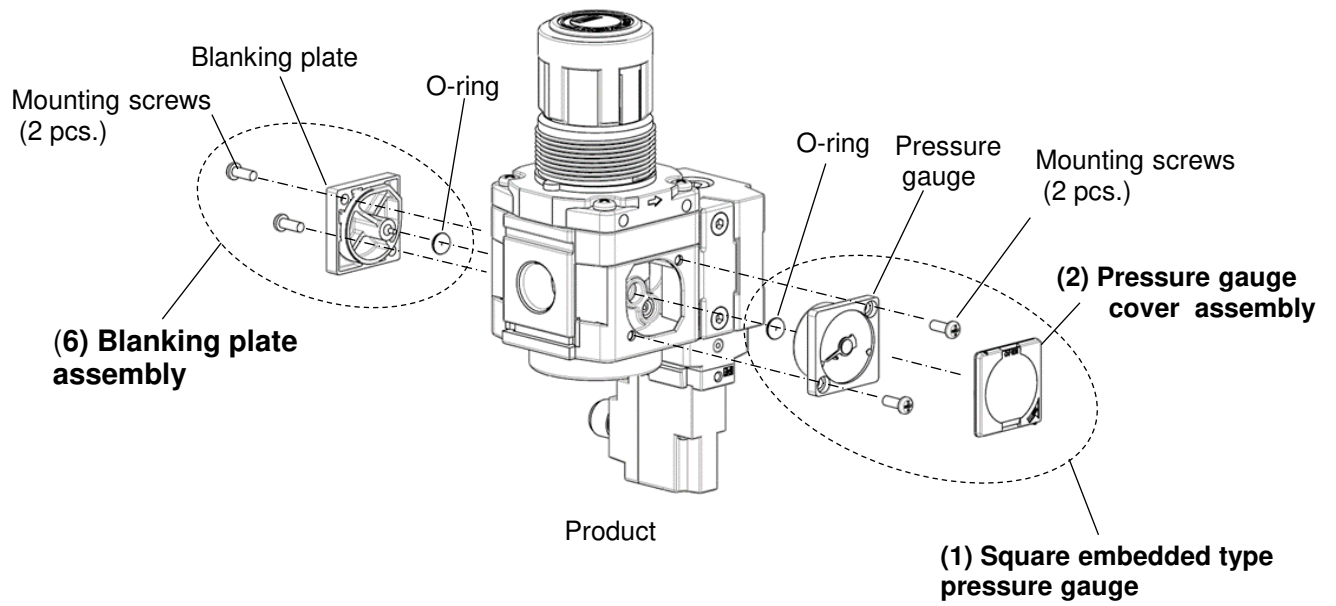

- When swapping (1) Square embedded type pressure gauge, tighten them with  $0.85 \pm 0.05 \text{ N} \cdot \text{m}$ . Tighten others with  $0.6 \pm 0.05 \text{ N} \cdot \text{m}$ .

# 10. Dimensions

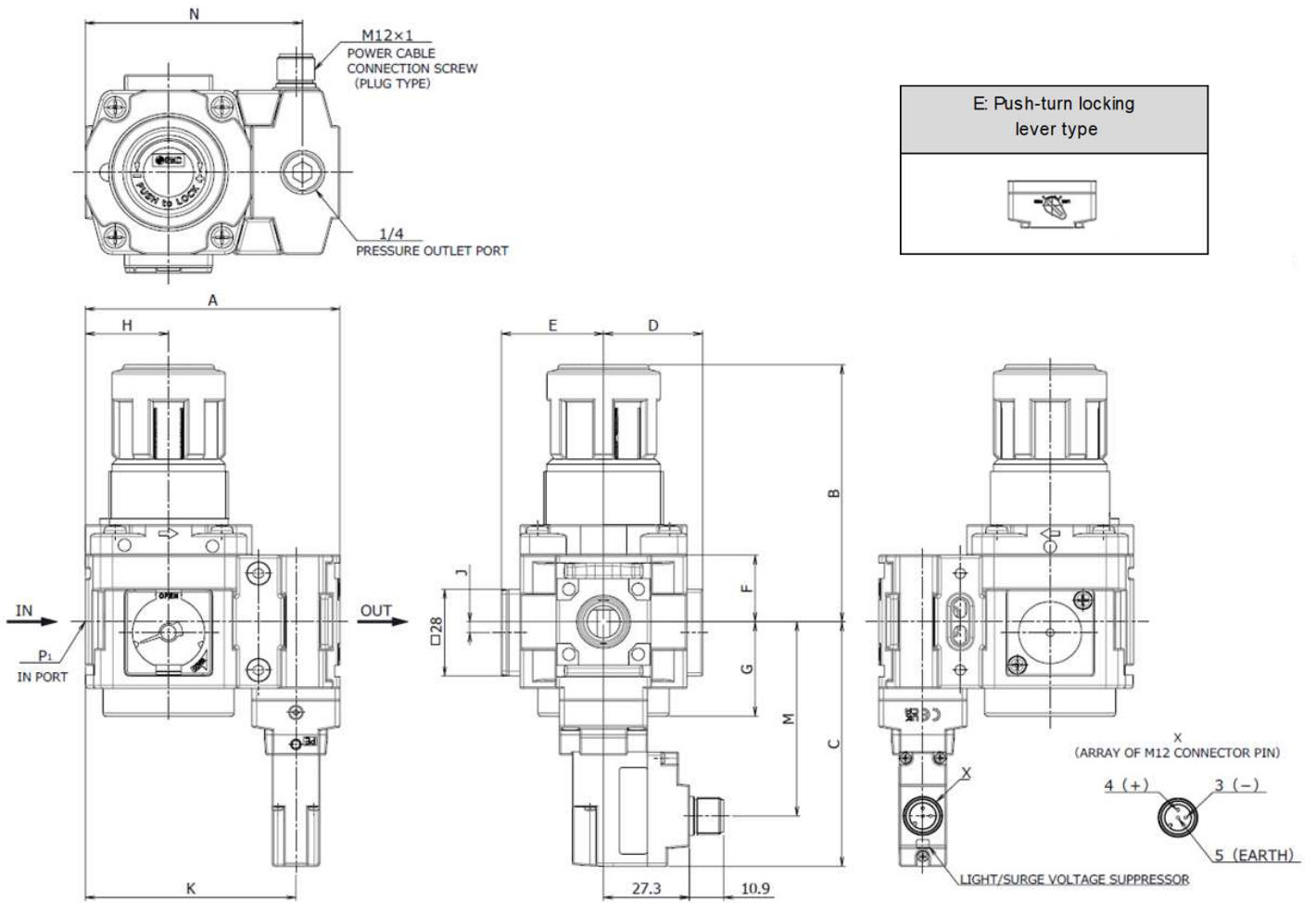

## Dimensions

Model	P <sub>1</sub>	A	B	C	D	E	F	G	H	J	K	M	N
AR20S	1/4	68	66.8	73	26	27	17.5	26.5	20	2	54	56.7	55.6
AR30S	3/8	81	86.5	79	31.5	32.5	21.5	30.5	26.5	3.5	67	62.7	69.1
AR40S	1/2	98	91.5	83	40.5	41.5	25.5	35.5	35	-	84	66.7	86.6
AR50S	1	118	125	90.5	50	51	32	43	45	-	104	74.2	105

The dimension of B is the length when the regulator knob is unlocked.

Revision history

1	Correction of errors	Nov.2022
---	----------------------	----------

# SMC Corporation

4-14-1, Sotokanda, Chiyoda-ku, Tokyo 101-0021 JAPAN  
Tel: + 81 3 5207 8249 Fax: +81 3 5298 5362  
URL <https://www.smcworld.com>