

Fieldbus system
CC-Link Compatible GW unit

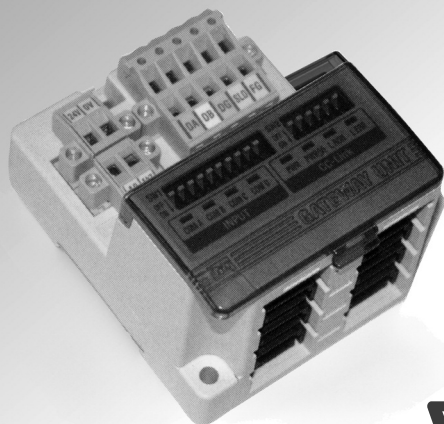

Operation Manual

EX510-GMJ1



SMC Corporation URL <http://www.smcworld.com>

Akihabara UDX 15F, 4-14-1, Sotokanda, Chiyoda-ku, Tokyo 101-0021, JAPAN
Phone: +81 3-5207-8249 Fax: +81 3-5298-5362

Note: Specifications are subject to change without prior notice and any obligation on the part of the manufacturer.

© 2003-2017 SMC Corporation All Rights Reserved

EX※※-OMH0014-C

Table of Contents

Thank you for purchasing an SMC fieldbus system EX510 series.

Please read this manual carefully before operating the product and make sure you understand its capabilities and limitations. Please keep this manual handy for future reference.

Safety Instructions	2
Product Summary	6
Name of Parts/ Accessories	7
Dimensions	8
Settings	9
Specifications	11
Wiring	12
Display/ Switch Setting	19
Troubleshooting	23

OPERATOR

- This operation manual has been written for those who have knowledge of machinery and apparatuses that use fieldbus system and have full knowledge of assembly, operation and maintenance of such equipment.
- Please read this operation manual carefully and understand it before assembling, operating or providing maintenance service to the actuator.

Safety Instructions

The product and this manual contain essential information to protect users and others from possible injury and property damage and to ensure correct handling.

Please check that you fully understand the definition of the following messages (signs) before going on to read the text, and always follow the instructions.

Please read the operation manual of related apparatus and understand it before operating the actuator.

IMPORTANT MESSAGES	
Read this manual and follow its instructions. Signal words such as WARNING, CAUTION and NOTE, will be followed by important safety information that must be carefully reviewed.	
⚠WARNING	Indicates a potentially hazardous situation which could result in death or serious injury if you do not follow instructions.
⚠CAUTION	Indicates a potentially hazardous situation which if not avoided, may result in minor injury or moderate injury.
NOTE	Gives you helpful information.

⚠WARNING

Do not disassemble, modify (including change of printed circuit board) or repair.

An injury or failure can result.

Do not operate the product outside of the specifications.

Fire, malfunction, or damage to the product can result.

Verify the specifications before use.

Do not operate in an atmosphere containing flammable or explosive gases.

Fire or an explosion can result.

This product is not designed to be explosion proof.

If using the product in an interlocking circuit:

•**Provide a double interlocking system, for example a mechanical system.**

•**Check the product regularly for proper operation.**

Otherwise malfunction can result, causing an accident.

The following instructions must be followed during maintenance:

•**Turn off the power supply.**

•**Stop the air supply, exhaust the residual pressure and verify that the air is released before performing maintenance.**

Otherwise an injury can result.

⚠CAUTION

After maintenance is complete, perform appropriate functional inspections.

Stop operation if the equipment does not function properly.

Safety cannot be assured in the case of unexpected malfunction.

Provide grounding to assure the noise resistance of the product.

Individual grounding should be provided close to the product with a short cable.

Safety Instructions (continued)

Note

- When conformity to UL is required, the SI unit should be used with a UL1310 Class 2 power supply.

Follow the instructions given below when handling your product.

Or, it will have a risk of being damaged and operating failure.

- Operate product with the specified voltage.
- Reserve a space for maintenance.
- Do not remove labels.
- Do not drop, hit or apply excessive shock to the product.
- Follow the specified tightening torque.
- Never mount a product in a location that will be used as a foothold.
- Do not bend or apply tensile force to cables, or apply force by placing heavy load on them.
- Connect wires and cables correctly.
- Do not connect wires while the power is on.
- Do not lay wires or cables with power line or high-voltage line in the same wiring route.
- Verify the insulation of wiring.
- Separate power line for solenoid valves from power line for Input and control unit.
- Take appropriate measures against noise, such as using a noise filter, when the product is incorporated into equipment.
- Select the proper type of protection according to the environment of operation.

- Take sufficient shielding measures when installing at the following place.
 - (1) A place where noise due to static electricity is generated
 - (2) A place where electric field strength is high
 - (3) A place where there is radioactive irradiation
 - (4) A place near power line
- Do not use the product near by a place where electric surges are generated.
- When a surge-generating load such as a relay or solenoid is driven directly, use an product with a built-in surge absorbing element.
- The product is CE marked, but not immune to lightning strikes. Take measures against lightning strikes in the system.
- Prevent foreign matter such as remnant of wires from entering the product to avoid failure and malfunction.
- Mount the product in a place that is not exposed to vibration or impact.
- Do not use the product in an environment that is exposed to temperature cycle.
- Do not expose the product to direct sunlight.
- Keep the specified ambient temperature range.
- Do not expose the product to heat radiation from a heat source located nearby.
- Set the switches by using a sharp-pointed screwdriver etc.
- Turn off the power supply, stop the supplied air, exhaust the residual pressure and verify the release of air before performing maintenance.
- Perform maintenance and check regularly.
- Perform a proper functional check.
- Do not use solvents such as benzene, thinner etc. to clean the product.

Product Summary

System structure

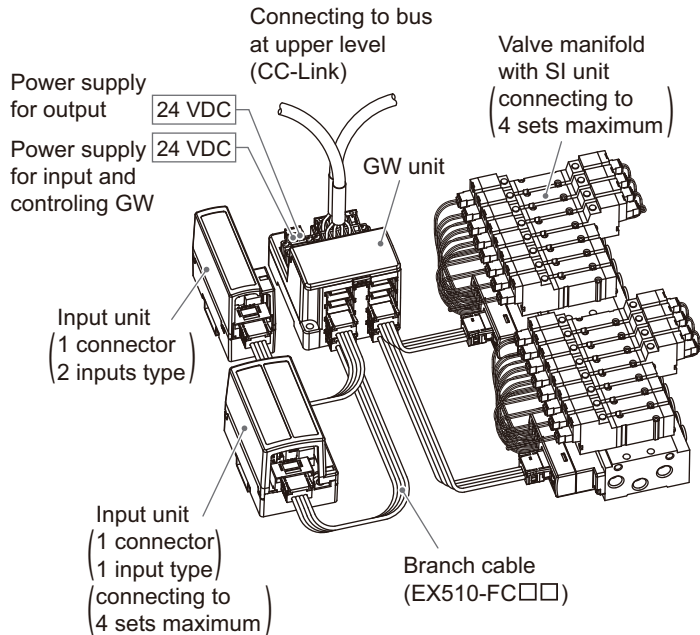

The system which realizes wiring saving and distributed installation by connecting to CC-Link. The signal to CC-Link is transmitted by GW unit, and the signal to input/output device which is installed discretely is collected by GW unit.

Name of Parts/ Accessories

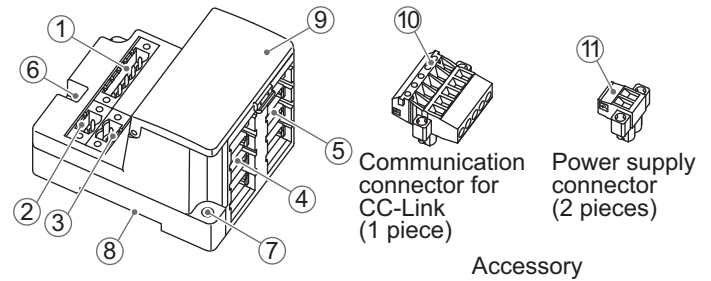

Accessory

No.	Parts	Purpose
1	Communication socket (BUS)	Connect to CC-Link line with an accessory connector for CC-Link (⑩). *
2	Power supply socket (PWR(V))	Supplying power for output instruments such as a solenoid valve with an accessory connector (⑪). *
3	Power supply socket (PWR)	Supplying power for controlling GW and for input instruments such as a sensor with an accessory connector (⑪). *
4	GW unit side branch connector (for input)	Connecting an input unit etc. by using branch cables (EX510-FC□□).
5	GW unit side branch connector (for output)	Connecting SI unit (manifold valve) etc. by using branch cables (EX510-FC□□).
6	FG terminal	Used for grounding
7	Mounting hole	Used when a unit is mounted with two M4 screws.
8	DIN rail mounting slot	Used when a unit is mounted to DIN rail.
9	Display/ switch setting part	Sets up the switch on such as LED display and address, I/O points.

*: For wiring method, refer to "Wiring" in the "Operation Manual".

Dimensions (in mm)

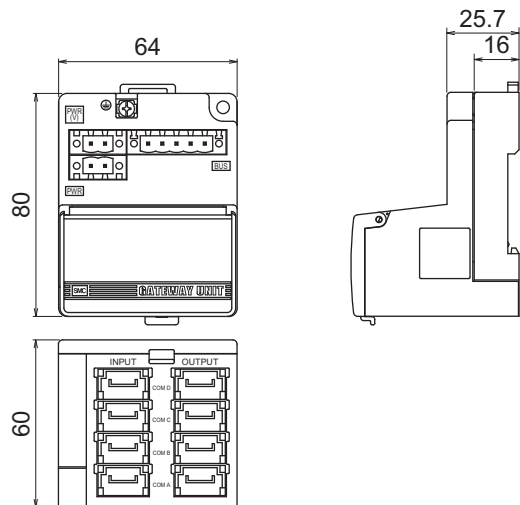

Settings

Mounted by screw

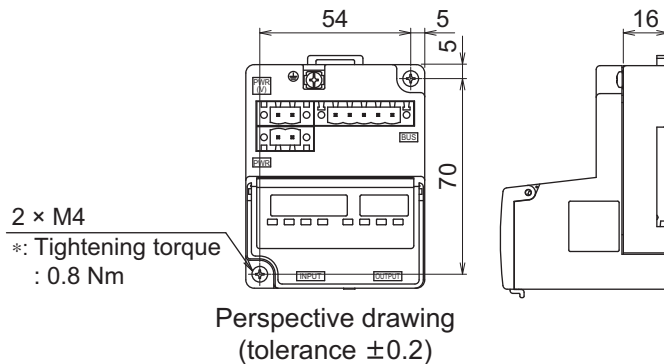

Mounted on DIN rail

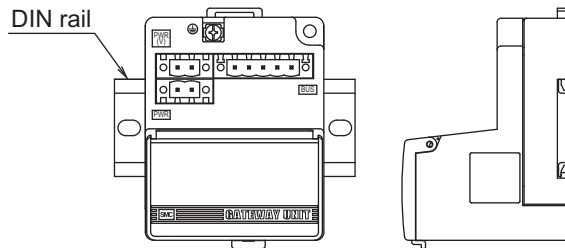

Settings (continued)

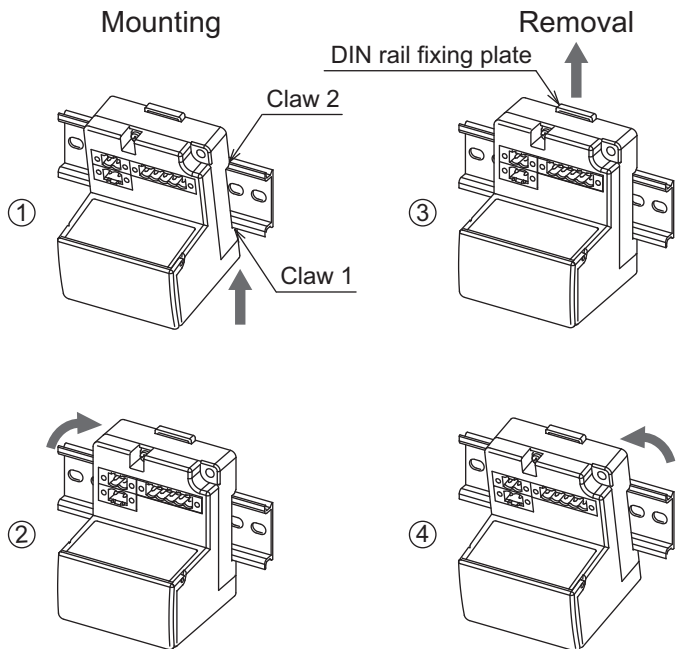

Put Claw 1 of the body under DIN rail and push it upward. Push down Claw 2 to the opposite rail until the claw clicks securely on to rail.

(Mounting procedure ① and ②)

For removing, lever up the DIN rail fixing plate of the body with a flat blade screwdriver, and remove it by tilting Claw 2 side forward.

(Removal procedure ③ and ④)

Specifications

Basic specifications

Rated voltage	24 VDC
Power supply voltage	Power supply for input and controlling GW: 24 VDC $\pm 10\%$ Power supply for output: 24 VDC $+10\%/-5\%$ (Warning for voltage drop is given at approx. 20 V)
Rated current	Power supply for input and controlling GW: Max. 4.1 A (Inside GW unit: 0.1 A, input unit: 4 A) Current for output: Max. 6 A
Input/ output point	Input point: Max. 64/ Output point: Max. 64 (Changeable by switch settings)
Operation temp. range	-10 to 50 °C

Higher-level bus

Compatible system	CC-Link Ver.1.10
Number of station occupied	3 stations (it is possible to change for 2 stations)
Station type	Remote device station

Communication speed	156 kbps	625 kbps	2.5 Mbps	5 Mbps	10 Mbps
Cable length between stations	20 cm and more				
Maximum extended cable length	1200 m	900 m	400 m	160 m	100 m

Lower level bus

Number of branches for input/ output	4 branches for input 4 branches for output
Communication type	Communication protocol: Dedicated for SMC Communication speed : 750 kbps
Current for input branch	Max. 1 A per branch
Current for output branch	Max. 1.5 A per branch
Branch cable length	At 0.75 A per branch: 20 m or less At 1.0 A per branch : 16 m or less At 1.5 A per branch : 10 m or less

*1: Input terminals are not isolated from Power source.

*2: Do not connect outside Power source to Input and Output terminals.

Wiring

Internal circuit

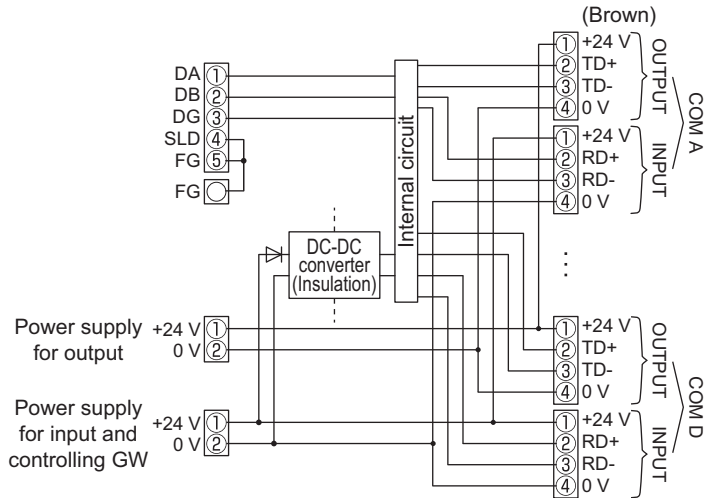

Branch wiring

The wiring between each unit should use branch cables, and be connected with branch connectors.

SI unit and Input unit have 2 branch connectors for each.

Pressure welding for branch connector

The method of pressure welding for branch connector is explained.

(1) Components

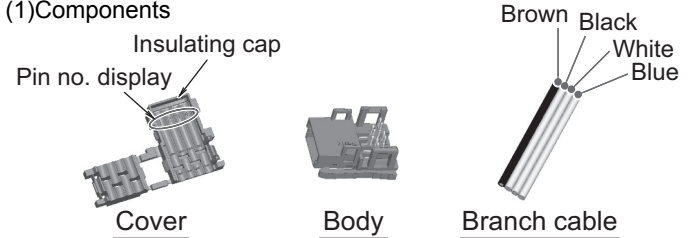

(2) Working procedure

① Set a branch cable to the cover.

- 1) Set the brown wire of the branch cable so that it comes to the pin #1.
- 2) Meet the cable end to the insulating cap at the cover.

- 3) Fold the cover so that the branch cable can be put between the cover.

- 4) Fix the latch tip by inserting to a hole for fixing latch.

Note) Check the color of wire written on a branch connector and the color of branch cable are same.

② Fix to a body tentatively.

Fit 4 latches on a body to 4 ditches on the cover, and press them until the latch engages to the level 1.

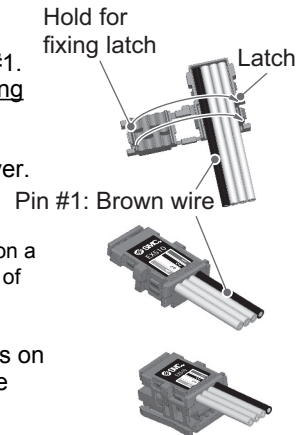

Wiring (continued)

- ③ Press fitting
Press the cover to the body with plier etc.
- ④ Confirmation
It is completed with a check on 4 latches engaging.

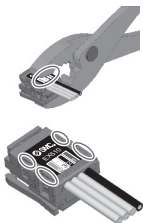

Wiring of branch cables

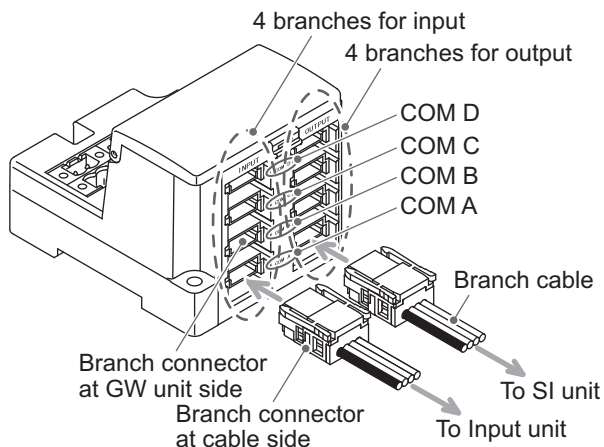

Insert branch connector on the table side from the bottom (COM A, B, C, D of branch connector of GW unit side).

NOTE

1. Select a branch cable length suitable to avoid stress being applied to the branch connector and cable, and provide sufficient cable length for maintenance.
2. Do not pull the branch connector and branch cable after wiring. There is a risk of damage.
3. Do not open and close the branch connector hook repeatedly. There is a risk of damage.
4. Cut the branch cable and replace the branch connector when the branch connector hook is broken or no longer functions.
5. Use SMC branch connector (product No.: EX510-LC1) and branch cable (product No.: EX510-FC□□). Usage of other branch connector or cable is out of the applicable range of product guarantee.

Communication wiring

Connect CC-Link dedicated cables to the communication connector for CC-Link.

- (1) Make sure to connect the signal cables to designated pins (Refer to Drawing 1).
And tighten the connector surely to 0.5 to 0.6 Nm tightening torque.

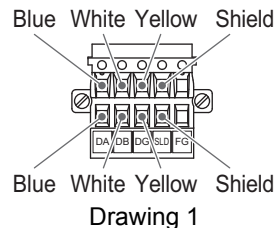

Wiring (continued)

- (2) Make sure to connect a "terminating resistor" to the units at the both ends of the system (Refer to Drawing 2).

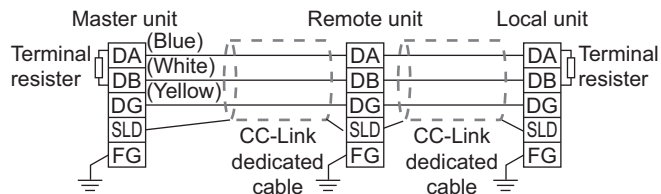

Drawing 2

Connect the terminal resistor between "DA-DB"
(Refer to Drawing 3).

Terminating resistor

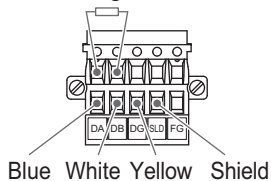

Drawing 3

- (3) The terminal resistor to connect differs depending on a cable to use at CC-Link system. Refer to table below.

Cable type	Terminal resistor
CC-Link dedicated cable	110 Ω 1/2 W
CC-Link dedicated cable compatible to Ver.1.10	(brown, brown, brown)
CC-Link dedicated high performance cable	130 Ω 1/2 W
	(brown, orange, brown)

- (4) Refer to Drawing 4 about how to connect to the unit.

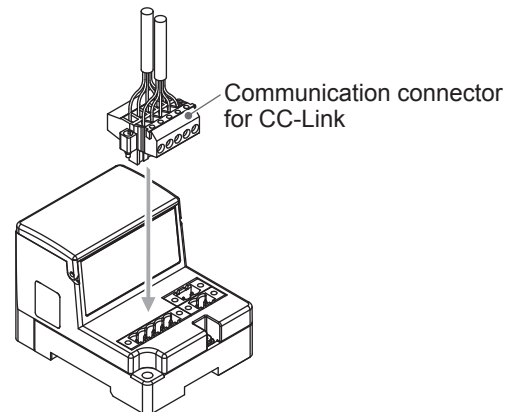

Drawing 4

NOTE

- CC-Link dedicated high performance cable cannot be mixed with other cables (CC-Link dedicated cable, CC-Link dedicated cable compatible with Ver.1.10).
If mixed, normal transmission of data cannot be assured.
- Connect the shield line of CC-Link dedicated cable to "SLD" of each unit.

Wiring (continued)

Power supply wiring

Connect power supply wiring to the two power supply 2-pin connectors. Power supply structure consists of 2 systems, but it can be used with both single power supply and separate power supply.

Individual power supply for other units is not necessary. Make sure of connection with the designated pin. Tighten the connector securely to 0.5 to 0.6 Nm tightening torque.

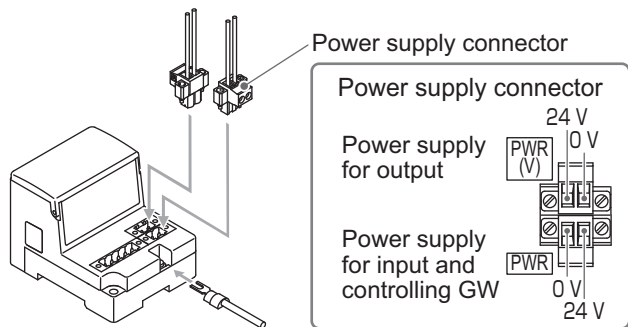

Note: A secure earth connection (Protection class 3) should be performed for FG terminal. (SLD, FG and FG terminal in communication connector for CC-Link are connected inside of GW unit.)

A. For dual power supply use

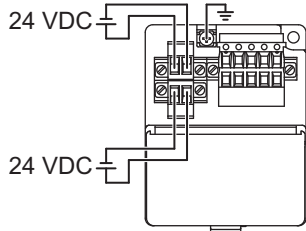

B. For single power supply use

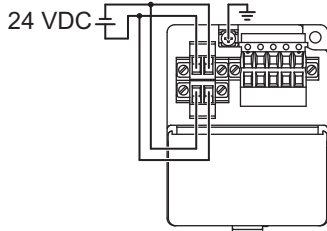

Display/ Switch Setting

Setting for Display

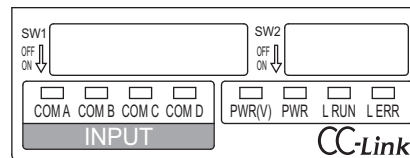

Display	Meaning
PWR (V)	The power for output is supplied at specified voltage: Lights up The power for output is not supplied at specified voltage: Goes off
PWR	The power for input and GW unit controlling part is supplied: Lights up The power for input and GW unit controlling part is not supplied: Goes off
L RUN	Normally communication: Lights up Communication interrupted: Goes off
L ERR	Communication error: Lights up Setting of station number and of transmitting speed setting switch is changed during powered: Lights up (Blink with 0.4 s interval) Normally communicating: Goes off
COM A	COM A is receiving data: Lights up * COM A is having no data to receive: Goes off
COM B	COM B is receiving data: Lights up * COM B is having no data to receive: Goes off
COM C	COM C is receiving data: Lights up * COM C is having no data to receive: Goes off
COM D	COM D is receiving data: Lights up * COM D is having no data to receive: Goes off

*: It is lit when input unit is connected and communicating normally.

Display/ Switch Setting (continued)

Switch setting

Make sure that switch setting is performed with power supply turned off. Open the cover, and set DIP switch with a small flat blade screwdriver, etc.

Setting of address and communication speed (SW1)

Setting of address and communication speed are performed with SW1.

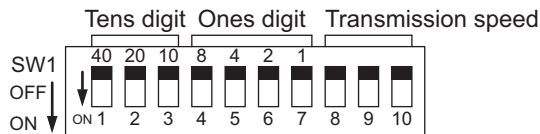

Station number setting (Switch No.1 to 7)

Set tens digit of station number 10, 20 and 40, and set ones digit of station number 1, 2, 4 and 8.

All setting are turned OFF at shipment and no station number is set. Make sure to set the station number in the range of 1 to 62 (with 3 stations occupied).

Station number	Tens digit (Switch No.)			Ones digit (Switch No.)			
	40 (No.1)	20 (No.2)	10 (No.3)	8 (No.4)	4 (No.5)	2 (No.6)	1 (No.7)
1	OFF	OFF	OFF	OFF	OFF	OFF	ON
2	OFF	OFF	OFF	OFF	OFF	ON	OFF
3	OFF	OFF	OFF	OFF	OFF	ON	ON
4	OFF	OFF	OFF	OFF	ON	OFF	OFF
:	:	:	:	:	:	:	:
10	OFF	OFF	ON	OFF	OFF	OFF	OFF
11	OFF	OFF	ON	OFF	OFF	OFF	ON
:	:	:	:	:	:	:	:
62	ON	ON	OFF	OFF	OFF	ON	OFF
63 *	ON	ON	OFF	OFF	OFF	ON	ON

*: Station number 63 can be set for 2 stations occupied type.

Swtting of transmission speed (Switch No.8 to 10)

Make sure to set the transmission speed in the range as follows. All setting are turned OFF at shipment, set to 156 kbps.

Transmission speed	No.8	No.9	No.10
156 kbps	OFF	OFF	OFF
625 kbps	OFF	OFF	ON
2.5 Mbps	OFF	ON	OFF
5 Mbps	OFF	ON	ON
10 Mbps	ON	OFF	OFF

Setting of HOLD/CLR, number of stations occupied and mode (SW2)

Setting of HOLD/CLR, number of stations occupied and mode are performed with SW2.

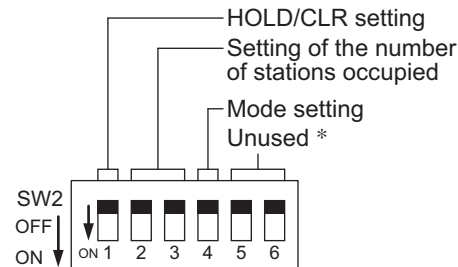

*: Switch No.5 and No.6 are unused. (Turn them OFF.)

HOLD/CLR setting (Switch No.1)

The setting is as follows.

The setting at shipment is turned OFF, set to CLR.

HOLD/CLR	No.1	Function
CLR	OFF	Output is cleared when an error occurs.
HOLD	ON	Output is held when an error occurs.

Display/ Switch Setting (continued)

Setting of the number of stations occupied (Switch No.2 to 3)

The setting of the number of stations occupied is performed with switch No.2 to 3.

3 stations are occupied at shipment.

Station setting	No.2	No.3	The max. available number of I/O point
2 station-occupied	OFF	ON	Input 32/ Output 32
3 station-occupied	ON	OFF	Input 64/ Output 64

Mode setting (Switch No.4)

Mode setting of each port is available only when 2 stations are occupied.

No.4 is used for mode setting.

The default setting is mode A.

Mode	No.4	Number of branch	Valid port
A	OFF	16 points per port	COM A and B
B	ON	8 points per port	COM A to D

Troubleshooting

Overall system

No.	Item	Remedy/ Disposal
1	Solenoid valve is not working	<ul style="list-style-type: none"> •Check the power for output (24 VDC) is supplied. •Check the branch cable is connected to SI unit. •Check the LED for power supply (PWR) and the LED for communication (COM) at SI unit are ON. •Ensure output branch current does not exceed the specification range.
2	Valve is not working as program directs	<ul style="list-style-type: none"> •Program it after checking the wiring specification of manifold block assembly.
3	Signals cannot be received even with a sensor	<ul style="list-style-type: none"> •Check the power for input and controlling GW (24 VDC) is supplied. •Check the input unit indication LED is ON. •Ensure input branch current does not exceed the specification range.
4	COM A-D is not LIT	<ul style="list-style-type: none"> •Check the connection of UNLIT COM port branch to input unit.

CC-Link compatible communication

No.	Item	Remedy/ Disposal
1	PWR LED is goes off	•Check the power supply for input and controlling GW (24 VDC) is supplied.
2	PWR(V) LED is goes off	•Check the power for output (24 VDC) is supplied. •Check the power supply voltage for output is getting as low as under 20 V.
3	RUN LED is goes off/ ERR LED is lights up	•Check the signal line from PLC is correctly connected. •Check the wiring and pin numbers. •Check the address setting is correct.
4	ERR LED is flushing	•Check the communication speed setting/ station number setting is changed halfway.

*: Refer to "Operation Manual" for detail of troubleshooting.
