



Operation Manual

PRODUCT NAME

SI unit for DeviceNet®

MODEL / Series / Product Number

EX250-SDN1
EX250-SDN1-X102

SMC Corporation

Table of Contents

Safety Instructions	2
Product Summary	8
Model indication and How to Order	9
Summary of Product parts	9
Mounting and Installation	10
Installation	10
Wiring	11
Indication and Settings	17
DeviceNet® objects	23
Maintenance	33
Troubleshooting	34
Specification	42
Specifications	42
Dimensions	43
Option	44



Safety Instructions

These safety instructions are intended to prevent hazardous situations and/or equipment damage. These instructions indicate the level of potential hazard with the labels of "Caution", "Warning" or "Danger". They are all important notes for safety and must be followed in addition to International Standards (ISO/IEC)*1), and other safety regulations.

*1) ISO 4414: Pneumatic fluid power -- General rules relating to systems.

ISO 4413: Hydraulic fluid power -- General rules relating to systems.

IEC 60204-1: Safety of machinery -- Electrical equipment of machines .(Part 1: General requirements)

ISO 10218: Manipulating industrial robots -Safety.

etc.



Caution

Caution indicates a hazard with a low level of risk which, if not avoided, could result in minor or moderate injury.



Warning

Warning indicates a hazard with a medium level of risk which, if not avoided, could result in death or serious injury.



Danger

Danger indicates a hazard with a high level of risk which, if not avoided, will result in death or serious injury.

Warning

1. The compatibility of the product is the responsibility of the person who designs the equipment or decides its specifications.

Since the product specified here is used under various operating conditions, its compatibility with specific equipment must be decided by the person who designs the equipment or decides its specifications based on necessary analysis and test results.

The expected performance and safety assurance of the equipment will be the responsibility of the person who has determined its compatibility with the product.

This person should also continuously review all specifications of the product referring to its latest catalog information, with a view to giving due consideration to any possibility of equipment failure when configuring the equipment.

2. Only personnel with appropriate training should operate machinery and equipment.

The product specified here may become unsafe if handled incorrectly.

The assembly, operation and maintenance of machines or equipment including our products must be performed by an operator who is appropriately trained and experienced.

3. Do not service or attempt to remove product and machinery/equipment until safety is confirmed.

1. The inspection and maintenance of machinery/equipment should only be performed after measures to prevent falling or runaway of the driven objects have been confirmed.

2. When the product is to be removed, confirm that the safety measures as mentioned above are implemented and the power from any appropriate source is cut, and read and understand the specific product precautions of all relevant products carefully.

3. Before machinery/equipment is restarted, take measures to prevent unexpected operation and malfunction.

4. Contact SMC beforehand and take special consideration of safety measures if the product is to be used in any of the following conditions.

1. Conditions and environments outside of the given specifications, or use outdoors or in a place exposed to direct sunlight.

2. Installation on equipment in conjunction with atomic energy, railways, air navigation, space, shipping, vehicles, military, medical treatment, combustion and recreation, or equipment in contact with food and beverages, emergency stop circuits, clutch and brake circuits in press applications, safety equipment or other applications unsuitable for the standard specifications described in the product catalog.

3. An application which could have negative effects on people, property, or animals requiring special safety analysis.

4. Use in an interlock circuit, which requires the provision of double interlock for possible failure by using a mechanical protective function, and periodical checks to confirm proper operation.



Safety Instructions

Caution

1. The product is provided for use in manufacturing industries.

The product herein described is basically provided for peaceful use in manufacturing industries. If considering using the product in other industries, consult SMC beforehand and exchange specifications or a contract if necessary.
If anything is unclear, contact your nearest sales branch.

Limited warranty and Disclaimer/Compliance Requirements

The product used is subject to the following "Limited warranty and Disclaimer" and "Compliance Requirements".

Read and accept them before using the product.

Limited warranty and Disclaimer

1. The warranty period of the product is 1 year in service or 1.5 years after the product is delivered, whichever is first.*2)

Also, the product may have specified durability, running distance or replacement parts. Please consult your nearest sales branch.

2. For any failure or damage reported within the warranty period which is clearly our responsibility, a replacement product or necessary parts will be provided.

This limited warranty applies only to our product independently, and not to any other damage incurred due to the failure of the product.

3. Prior to using SMC products, please read and understand the warranty terms and disclaimers noted in the specified catalog for the particular products.

***2) Vacuum pads are excluded from this 1 year warranty.**

A vacuum pad is a consumable part, so it is warranted for a year after it is delivered.

Also, even within the warranty period, the wear of a product due to the use of the vacuum pad or failure due to the deterioration of rubber material are not covered by the limited warranty.

Compliance Requirements

1. The use of SMC products with production equipment for the manufacture of weapons of mass destruction (WMD) or any other weapon is strictly prohibited.

2. The exports of SMC products or technology from one country to another are governed by the relevant security laws and regulation of the countries involved in the transaction. Prior to the shipment of a SMC product to another country, assure that all local rules governing that export are known and followed.

Operator

- ◆ This operation manual is intended for those who have knowledge of machinery using pneumatic equipment, and have sufficient knowledge of assembly, operation and maintenance of such equipment. Only those persons are allowed to perform assembly, operation and maintenance.
- ◆ Read and understand this operation manual carefully before assembling, operating or providing maintenance to the product.

■ Safety Instructions

Warning

- Do not disassemble, modify (including changing the printed circuit board) or repair.
An injury or failure can result.
- Do not operate the product outside of the specifications.
Do not use for flammable or harmful fluids.
Fire, malfunction, or damage to the product can result.
Verify the specifications before use.
- Do not operate in an atmosphere containing flammable or explosive gases.
Fire or an explosion can result.
This product is not designed to be explosion proof.
- If using the product in an interlocking circuit:
 - Provide a double interlocking system, for example a mechanical system.
 - Check the product regularly for proper operation.Otherwise malfunction can result, causing an accident.
- The following instructions must be followed during maintenance:
 - Turn off the power supply.
 - Stop the air supply, exhaust the residual pressure and verify that the air is released before performing maintenance.Otherwise an injury can result.

Caution

- After maintenance is complete, perform appropriate functional inspections.
Stop operation if the equipment does not function properly.
Safety cannot be assured in the case of unexpected malfunction.
- Provide grounding to assure the noise resistance of the Fieldbus system.
Individual grounding should be provided close to the product with a short cable.

■ NOTE

- Follow the instructions given below when designing, selecting and handling the product.
- The instructions on design and selection (installation, wiring, environment, adjustment, operation, maintenance, etc.) described below must also be followed.
 - *Product specifications
 - When conformity to UL is necessary the SI unit must be used with a UL1310 Class 2 power supply.
 - The SI unit is a UL approved product only if they have a  mark on the body.
 - Use the specified voltage.
Otherwise failure or malfunction can result.
 - Reserve a space for maintenance.
Allow sufficient space for maintenance when designing the system.
 - Do not remove any nameplates or labels.
This can lead to incorrect maintenance, or misreading of the operation manual, which could cause damage or malfunction to the product.
It may also result in non-conformity to safety standards.

•Product handling

*Installation

- Do not drop, hit or apply excessive shock to the fieldbus system.
Otherwise damage to the product can result, causing malfunction.
- Tighten to the specified tightening torque.
If the tightening torque is exceeded the mounting screws may be broken.
IP67 protection cannot be guaranteed if the screws are not tightened to the specified torque.
- Never mount a product in a location that will be used as a foothold.
The product may be damaged if excessive force is applied by stepping or climbing onto it.

*Wiring

- Avoid repeatedly bending or stretching the cables, or placing heavy load on them.
Repetitive bending stress or tensile stress can cause breakage of the cable.
- Wire correctly.
Incorrect wiring can break the product.
- Do not perform wiring while the power is on.
Otherwise damage to the fieldbus system and/or I/O device can result, causing malfunction.
- Do not route wires and cables together with power or high voltage cables.
Otherwise the fieldbus system and/or I/O device can malfunction due to interference of noise and surge voltage from power and high voltage cables to the signal line.
Route the wires (piping) of the fieldbus system and/or I/O device separately from power or high voltage cables.
- Confirm proper insulation of wiring.
Poor insulation (interference from another circuit, poor insulation between terminals, etc.) can lead to excess voltage or current being applied to the product, causing damage.
- Take appropriate measures against noise, such as using a noise filter, when the fieldbus system is incorporated into equipment.
Otherwise noise can cause malfunction.

*Environment

- Select the proper type of protection according to the environment of operation.
IP67 protection is achieved when the following conditions are met.
(1) The units are connected properly with fieldbus cable with M12 connector and power cable with M12 (M8) connector.
(2) Suitable mounting of each unit and manifold valve.
If using in an environment that is exposed to water splashes, please take measures such as using a cover.
- Do not use in a place where the product could be splashed by oil or chemicals.
If the product is to be used in an environment containing oils or chemicals such as coolant or cleaning solvent, even for a short time, it may be adversely affected (damage, malfunction etc.).
- Do not use the product in an environment where corrosive gases or fluids could be splashed.
Otherwise damage to the product and malfunction can result.
- Do not use in an area where surges are generated.
If there is equipment which generates a large amount of surge (solenoid type lifter, high frequency induction furnace, motor, etc.) close to the fieldbus system, this may cause deterioration or breakage of the internal circuit of the fieldbus system. Avoid sources of surge generation and crossed lines.
- When a surge-generating load such as a relay or solenoid is driven directly, use a fieldbus system with a built-in surge absorbing element.
Direct drive of a load generating surge voltage can damage the fieldbus system.
- The product is CE marked, but not immune to lightning strikes. Take measures against lightning strikes in the system.
- Prevent foreign matter such as remnant of wires from entering the fieldbus system to avoid failure and malfunction.

- Mount the product in a place that is not exposed to vibration or impact.
Otherwise failure or malfunction can result.
- Do not use the product in an environment that is exposed to temperature cycle.
Heat cycles other than ordinary changes in temperature can adversely affect the inside of the product.
- Do not expose the product to direct sunlight.
If using in a location directly exposed to sunlight, shade the product from the sunlight.
Otherwise failure or malfunction can result.
- Keep within the specified ambient temperature range.
Otherwise malfunction can result.
- Do not operate close to a heat source, or in a location exposed to radiant heat.
Otherwise malfunction can result.

*Adjustment and Operation

- Set the switches by using a sharp-pointed screwdriver etc.
It may damage set switches.
- Perform settings suitable for the operating conditions.
Incorrect setting can cause operation failure.
For details of each setting, refer to page 17 of this manual.
- Please refer to the PLC manufacturer's manual etc. for details of programming and addresses.
For the PLC protocol and programming refer to the relevant manufacturer's documentation.

*Maintenance

- Turn off the power supply, stop the supplied air, exhaust the residual pressure and verify the release of air before performing maintenance.
There is a risk of unexpected malfunction.
- Perform regular maintenance and inspections.
There is a risk of unexpected malfunction.
- After maintenance is complete, perform appropriate functional inspections.
Stop operation if the equipment does not function properly.
Otherwise safety is not assured due to an unexpected malfunction or incorrect operation.
- Do not use solvents such as benzene, thinner etc. to clean the each unit.
They could damage the surface of the body and erase the markings on the body.
Use a soft cloth to remove stains.
For heavy stains, use a cloth soaked with diluted neutral detergent and fully squeezed, then wipe up the stains again with a dry cloth.

Product Summary

System configuration

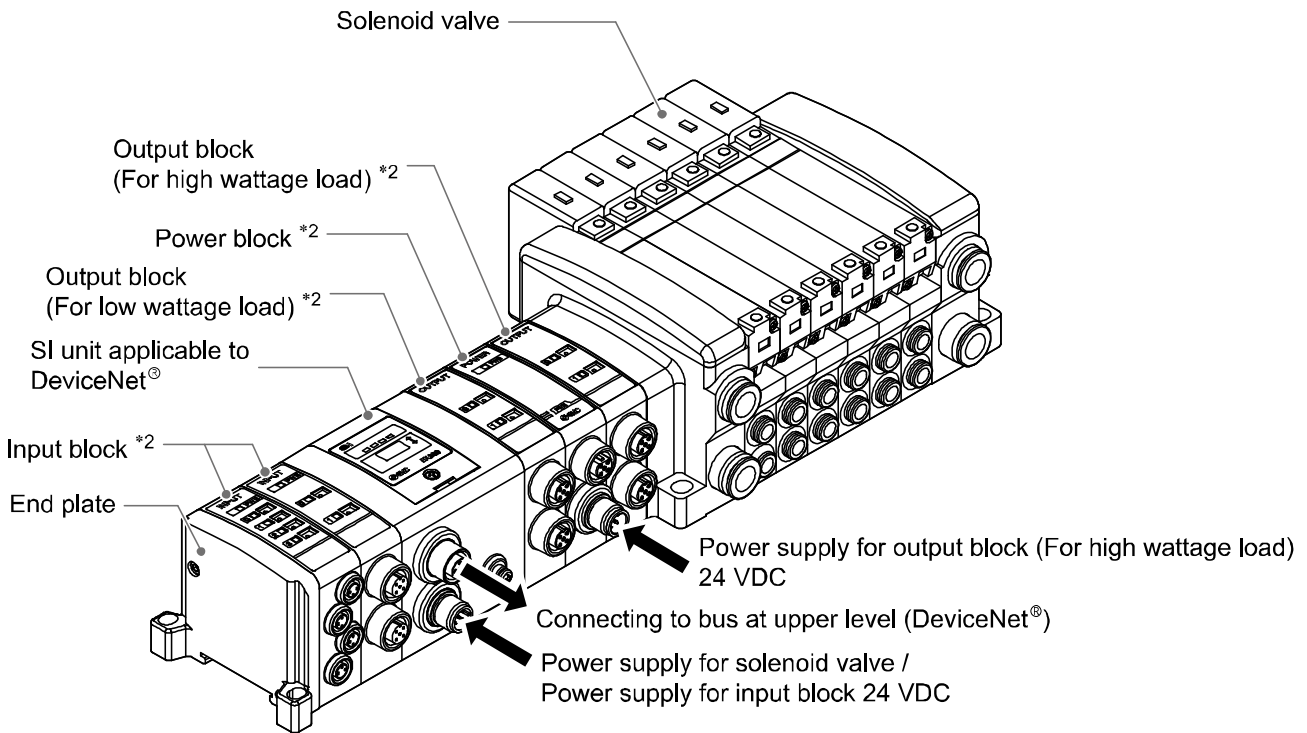

This system connects input/output devices to DeviceNet® with reduced wiring. DeviceNet® communicates with the input/output devices via the SI unit.

Input block and output block/valve manifolds of the EX9 series can be connected to 32 input points or 32 output points*1 maximum.

*1: The maximum output points when the valve manifold or power block of the VQC series or S0700 series is used is 24 maximum

*2: Refer to the operation manual EX※※-OME0002 for the input block specifications, and EX※※-OMH0005 for the output block and power block specifications.

Model indication and How to Order

EX250-SDN1

- Communication protocol

DN1	DeviceNet®
DN1-X102	DeviceNet® with diagnostic information transmission function

Summary of Product parts

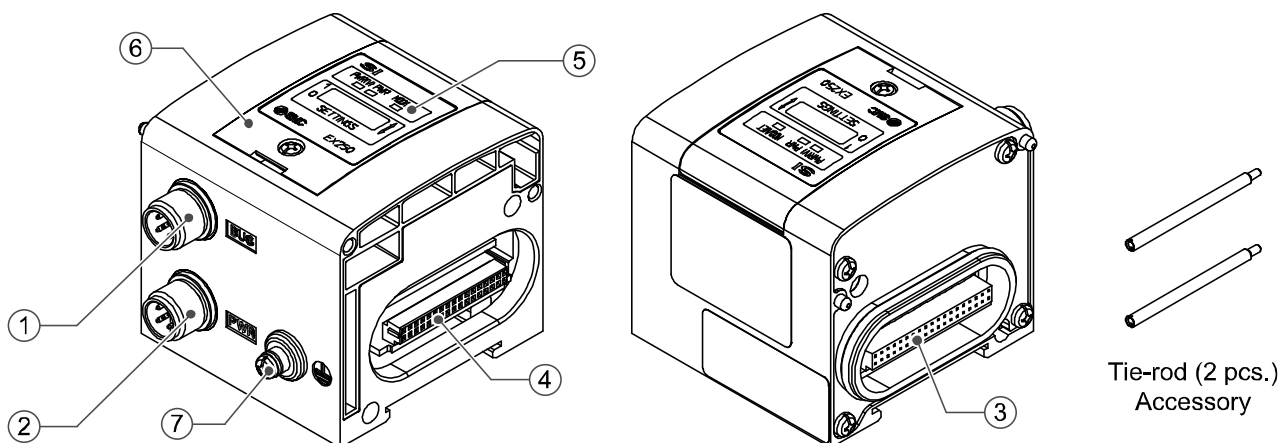

No.	Element	Description
1	Communication connector	Sends or receives communication signals via DeviceNet® line. *1
2	Power supply connector	Supplies power to the solenoid valve, output block, SI unit and input block. *1
3	Input block connector	Connects the input block
4	Output block connector	Connects the solenoid valve or output block etc.
5	Display window	Displays the status of the SI unit with LEDs. *2
6	Switch cover	Address and communication speed, etc. are set with the switches inside it. *2
7	Grounding terminal (FE)	Used for grounding.

*1: Refer to "Wiring" on page 11 of this operation manual.

*2: Refer to "Indication and settings" on page 17 of this operation manual.

Mounting and Installation

■ Installation

The SI unit does not have mounting holes, so it cannot be installed alone. Make sure to connect the valve manifold. When an input block is not required, connect the end plate directly to the SI unit.

○ Installation example

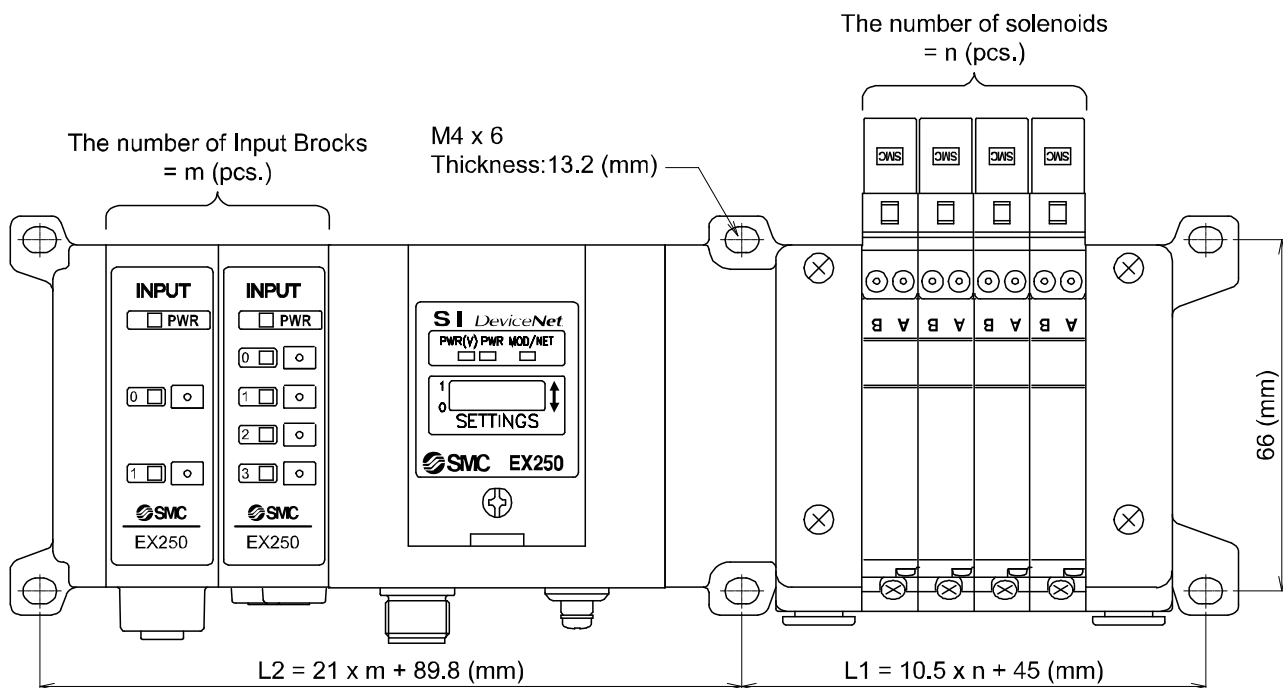

L \ N*m	0	1	2	3	4	5	6	7	8	9	10	11	12	13	14	15	16
L1	45	55.5	66	76.5	87	97.5	108	118.5	129	139.5	150	160.5	171	181.5	192	202.5	213
L2	89.8	110.8	131.8	152.8	173.8	194.8	215.8	236.8	257.8	278.8	299.8						

(mm)

*: L1 shows the dimensions of the VQC1000 series solenoid valve.
Refer to the individual specifications for other solenoid valve series.

■Wiring

Connect the appropriate cable connector to the connector on the SI unit as shown below.

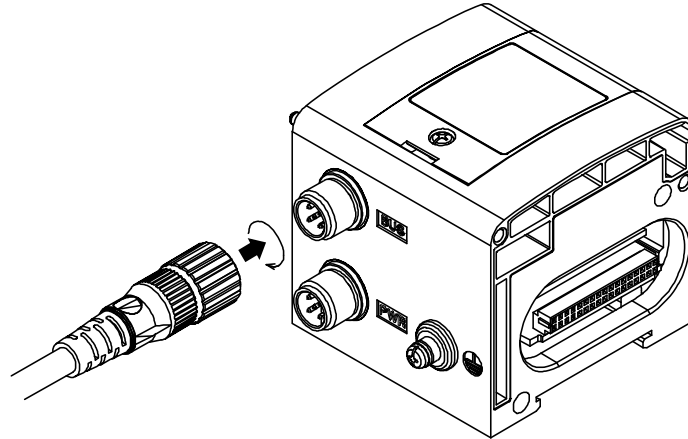

○Communication wiring

The DeviceNet® communication connector specifications are shown below.

M12 5-pin plug A-code

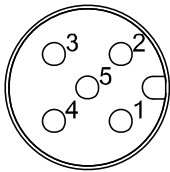

Pin No.	Signal name
1	DRAIN
2	V+
3	V-
4	CAN_H
5	CAN_L

Note

Wiring should be carried out with the power supply turned off.

Do not route the communication cable near to high voltage cables such as a power cable or high current electrical cable.

Make sure to connect terminal resistors to both ends of the DeviceNet® main cable.

The drain wire should be connected to ground at one point only in the communication network.

Grounding should only be made at one point.



Pin Layout and Wiring of DeviceNet® Communication Connector Cable.....

Connect the M12 connector cable (socket) to the communication connector.

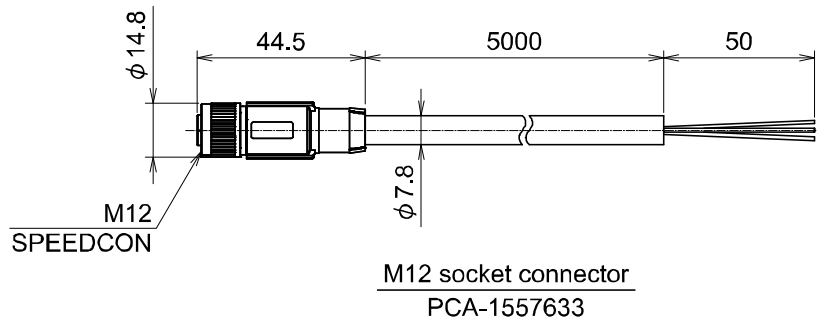

Pin No.	Cable colour: Signal
1	DRAIN
2	Red: V+
3	Black: V-
4	White: CAN_H
5	Blue: CAN_L

○ DeviceNet® Media Topology

A shielded twisted pair cable for DeviceNet® should be used.

The maximum cable length depends on the communication speed and the cable type used.

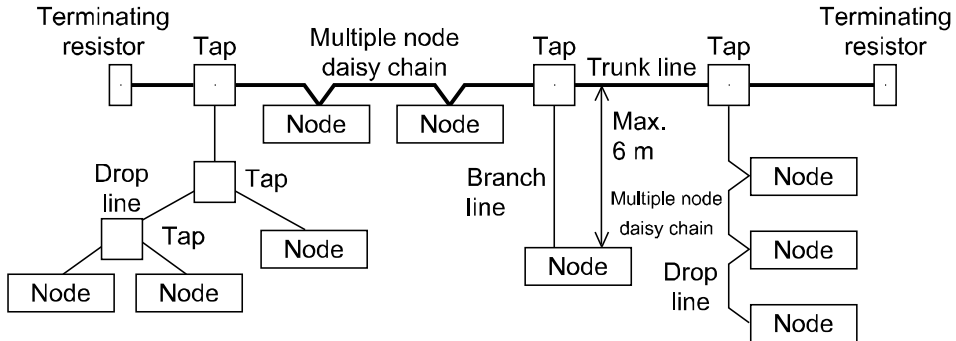

<Communication speed [kbps] and max. bus cable length>

Communication speed	Maximum cable length for network		Drop line length	Cumulative Drop
	Thick cable	Thin cable		
500 kbps	100 m	100 m	6 m or less	39 m max
250 kbps	250 m	100 m		78 m max
125 kbps	500 m	100 m		156 m max

○ Terminating resistors

DeviceNet® requires a terminating resistor to be installed at each end of the trunk.

The resistor requirements are:

- 121 Ω
- 1% metal film
- 1/4 W

Terminating resistors should not be installed at the end of a drop line, only at the two ends of trunk line.

○Power supply wiring

Connect a power supply cable connector to the power supply connector on the SI unit.
 Refer to "Safety Instructions" on page 2 of this operation manual for the selection of the power supply.

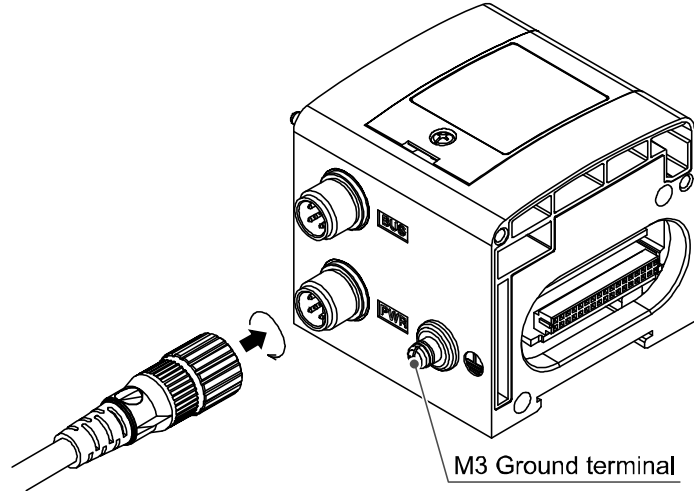

○Power supply connector

(M12 5-pin B-code (reverse))

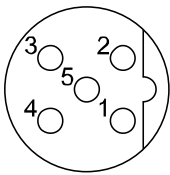

Pin No.	Description	Function
1	SV24 V	+24 V for solenoid valve
2	SV0 V	0 V for solenoid valve
3	SW24 V	+24 V for input block
4	SW0 V	0 V for input block
5	FE	Ground

Pin Layout and Wiring of Power Supply Connector Cable

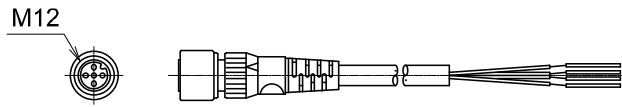

M12 connector cable
EX9-AC□-1

Pin No.	Cable color: Signal
1	Brown: SV24 V
2	White: SV0 V
3	Blue: SW24 V
4	Black: SW0 V
5	Grey: Ground

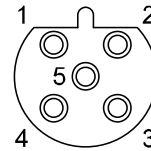

Socket connector pin layout

○FE connection

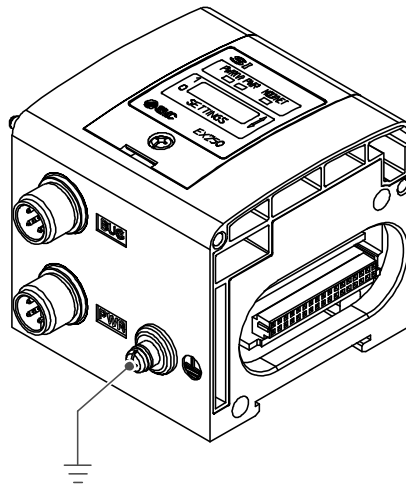

Note

Connect the ground terminal to the ground. Resistance to the ground should be 100 ohms or less.

Within the SI unit there are separate power supply lines for the solenoid valves (SV power supply) and for the input block (SW power supply). Supply 24 V DC to each of them. Power can be supplied from a single power supply or from separate power supplies. It is not necessary to connect the SW power supply when not using an input block.

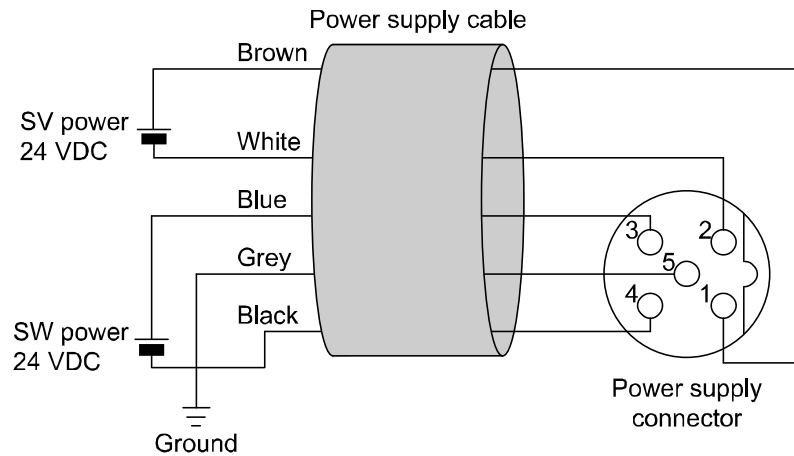

A. Dual power supply

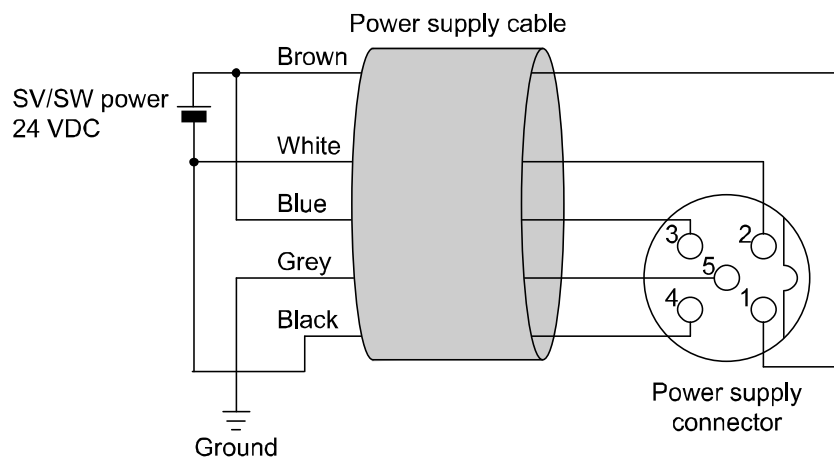

B. Single power supply

*: When a single power supply is used, the voltage range of each power supply should be noted.

SW power is supplied to the sensor connected to the input block. There is a voltage drop of approximately 1 V maximum inside the SI unit when SW power is supplied. Select a sensor taking this voltage drop into consideration. If 24 V must be supplied to the sensor, it is necessary to increase the SW power supply voltage so that the input voltage of the sensor will be 24 V with the actual load. (Allowable SW power supply range: 19.2 V to 28.8 V)

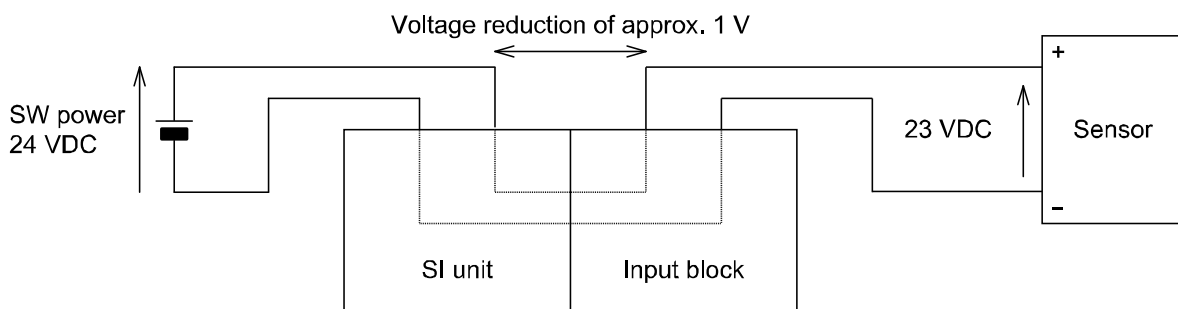

Indication and Settings

○ Indication

EX250-SDN1/EX250-SDN1-X102

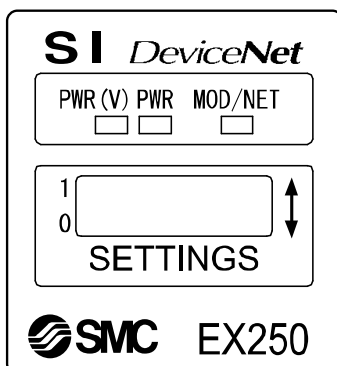

LED	Description	
PWR (V)	Green LED is ON when power for solenoid valve is supplied.	
PWR	Green LED is ON when power for DeviceNet® communication is supplied.	
MOD/NET	OFF	Power supply is off, on-line status or checking for MAC ID duplication.
	Green LED is flashing	I/O connection stand-by (on-line status)
	Green LED is ON	I/O connection established (on-line status)
	Red LED is flashing	I/O connection time-out (minor communication error) *
	Red LED is ON	MAC ID duplication error or BUS OFF error (serious communication error)

*: EX250-SDN1 disconnects the I/O connection when the solenoid valve power supply decreases or when the input block fuse is detected to be broken (EX250-SDN1-X102 does not disconnect the I/O connection).

○ Switch setting

Open the protective cover, and set the switches with a small flat blade screwdriver.

Note

1. The power supply should be off while setting the switches.
2. Be sure to set the switches before use.
3. After setting the switches, close the switch cover and tighten the screw to the specified torque.
(Tightening torque: 0.6 N•m)

Address setting

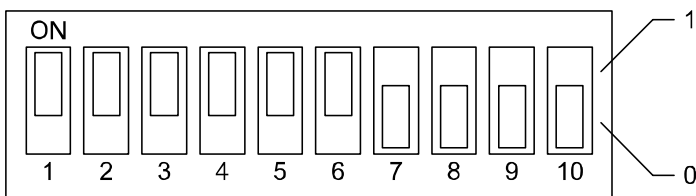

Node address
(MAC ID) setting

MAC ID	SW1-1	SW1-2	SW1-3	SW1-4	SW1-5	SW1-6
	2 ⁰ (1)	2 ¹ (2)	2 ² (4)	2 ³ (8)	2 ⁴ (16)	2 ⁵ (32)
0	0	0	0	0	0	0
1	1	0	0	0	0	0
2	0	1	0	0	0	0
:	:	:	:	:	:	:
62	0	1	1	1	1	1
63	1	1	1	1	1	1

Communication speed (Baud Rate)

Communication speed	SW1-7	SW1-8
125 kbps	0	0
250 kbps	1	0
500 kbps	0	1
Unused	1	1

Setting of solenoid output state in communication fault

Solenoid output state: Communication stops (I/O connection time out) or fault message is received.

SW1-9	Solenoid output state	
1	HOLD	All solenoid valve outputs are hold before communication fault.
0	CLEAR	All solenoid valve outputs are reset to zero.

Mode setting

SW1-10	Mode
0	H / W mode
	Set address and communication speed by SW1 to 8.
1	S / W mode
	Set address and communication speed by network1. *: SW1-1 to 8 are invalid.

DIP switch position

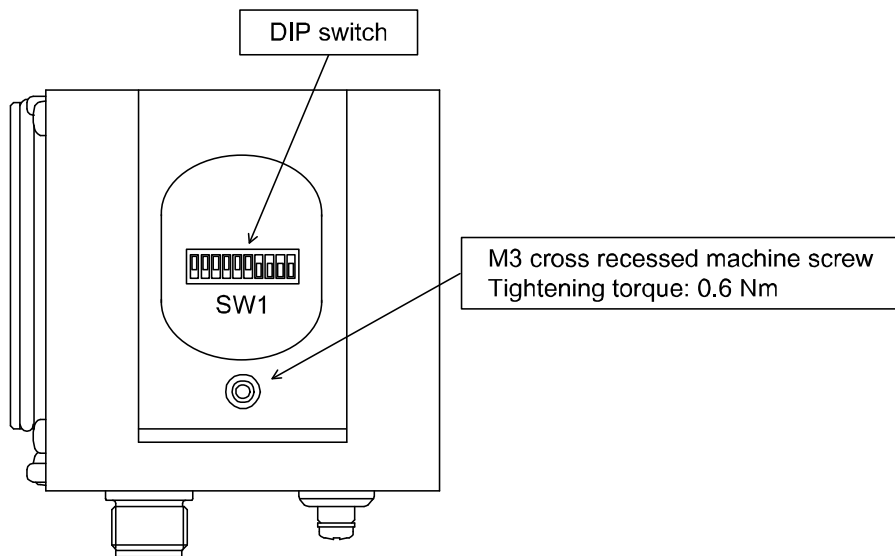

Caution

- The default settings are MAC ID 63 and communication speed 125 kbps (Hardware setting mode).
- The MAC ID and communication speed set in SW setting mode are maintained even when the SI unit power supply is turned off. When the power supply is applied in HW setting mode, the MAC ID and communication speed set in SW mode are deleted, and the MAC ID and communication speed set by the switches are memorized.

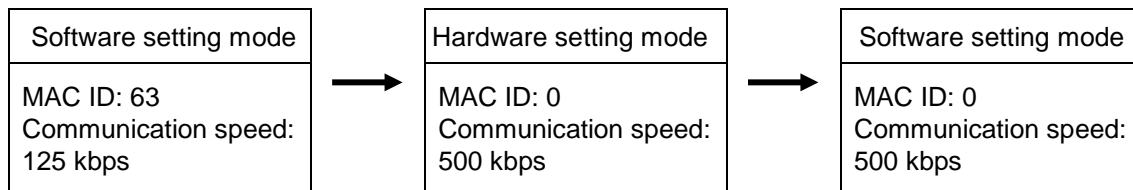

- The default output setting for when communication stops is 0 (all outputs to be cleared). The output setting for when communication stops can be changed individually for each point via the DeviceNet® communication network. In this case, SW1-9 settings will become invalid.

○ Settings via DeviceNet[®] network

It is possible to set the node address (MAC_ID), DeviceNet[®] communication speed and output condition when a communication error is generated, via the network, in accordance with the procedure below.

● Node address setting, communication speed setting

1) Turn SW1-10 on the SI unit ON (SW mode).

2) Change the instance attribute value below via the network.

Class	Instance	Attribute	Description	Value
03h (DeviceNet [®])	01h	01h	MAC ID (Node address)	0 to 63
	01h	02h	Baud_Rate (Communication speed)	0: 125 kbps 1: 250 kbps 2: 500 kbps

*: The address and communication speed set in SW mode will be maintained even after the DeviceNet[®] communication power supply to the SI unit is turned off.

When the power supply is applied in HW mode setting, the node address and communication speed set in SW mode are deleted and the value set by the switches is memorized.

● Output operation setting at the time of communication error

1) The instance attribute value below is set to 1 via the network.

Class	Instance	Attribute	Description	Value
64h (SMC)	01h	68h(104)	Hold Clear Timeout	0: Switch setting valid
				1: Fault action valid

2) Set the fault action and fault values via the network.

Fault setting method is the individual setting per output with DOP object.

Fault setting	Class	Instance	Attribute	Value
Fault action	09h (DOP)	n (Output No. + 1)	05h	0: Fault set value 1: Output held
Fault value			06h	0: CLEAR 1: SET

*: For details, refer to "Object mounting".

○SI unit I/O data (Poll command sent/received data)

EX250-SDN1

Item		Output (Poll request)	Input (Poll response)
No. of occupied bytes		4 bytes	4 bytes
Sent/Received data	Address +0	Output No. 0 to 7	Input No. 0 to 7
	Address +1	Output No. 8 to 15	Input No. 8 to 15
	Address +2	Output No. 16 to 23	Input No. 16 to 23
	Address +3	Output No. 24 to 31	Input No. 24 to 31

EX250-SDN1-X102

Item		Output (Poll request)	Input (Poll response)
No. of occupied bytes		4 bytes	6 bytes
Sent/Received data	Address +0	Output No. 0 to 7	Input No. 0 to 7
	Address +1	Output No. 8 to 15	Input No. 8 to 15
	Address +2	Output No. 16 to 23	Input No. 16 to 23
	Address +3	Output No. 24 to 31	Input No. 24 to 31
	Address +4	-	*1
	Address +5	-	*1

*1

Item		Bit (input)							
		7	6	5	4	3	2	1	0
Sent data	Address +4	Reserved area (State defined)							
	Address +5	Reserved			DI_CHK	SOLV	Reserved		

SOLV: Solenoid valve power supply (When power decreases (approx. 19 VDC or less): Displays "0", Normally: Displays "1").

DI_CHK: Detects broken fuse in the input block (When fuse is broken: Displays "0", Normally: Displays "1").

●EX250-SDN1 disconnects the I/O connection when either of the SOLV or DI_CHK is abnormal. (EX250-SDN1-X102 does not disconnect the I/O connection).

*: Mapping of the sent/received data depends on the PLC.

Refer to the Operation Manual of the PLC master unit (scanner) for details.

Applicable solenoid valve series

Main series	Applicable series
SY series	SY3000, SY5000, SY7000 (Connector connecting base)
VQC series	VQC1000, VQC2000, VQC4000, VQC5000
SV series	SV1000, SV2000, SV3000 (10 type tie-rod base)
S0700 series	S0700

○Output No. assignment

Combinations of output data and valve manifold

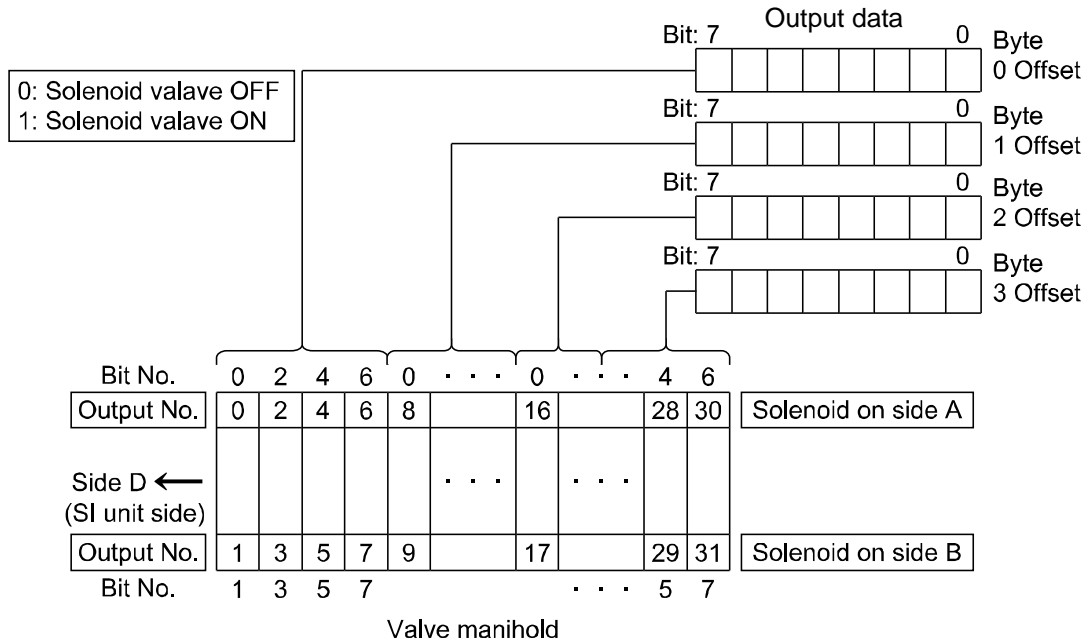

- *: Output No. starts from 0, and will be assigned to the valves in order from the SI unit mounted side.
- *: Manifold wiring is double wired as standard ("double wiring specification"), and the output numbers are assigned in order from A side to B side. If the mounted valves are single solenoid valves, the output on B side will be empty. (See Fig. a)
- *: Special wiring specification with a mixed wiring of single solenoid and double solenoid can be specified with a wiring specification sheet. This makes it possible to specify the output numbers without empty outputs. (See Fig. b)
- *: Each bit status, 0 or 1, of the data shows the ON or OFF solenoid valve status (0: OFF, 1: ON), and the output number starting from 0 will be assigned to from the lowest bit of the memory data.

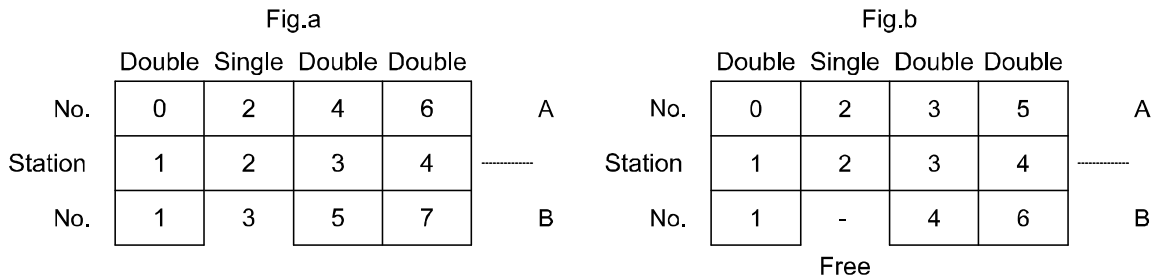

○Input No. assignment

Input numbers start from 0, and will be assigned to the input blocks in order from the SI unit mounted side.

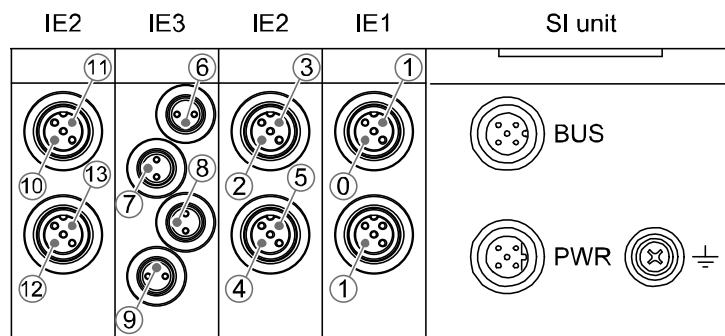

DeviceNet[®] Objects

○ DeviceNet[®] Objects

This SI unit supports the DeviceNet[®] object classes below, with pneumatic valves as the device type.

*: Hexadecimal value is used for □□h indication.

Class code	Object class
01h	Identity
02h	Message Router
03h	DeviceNet [®]
04h	Assembly
05h	DeviceNet [®] Connection
08h	Discrete Input Point
09h	Discrete Output Point
0Fh	Parameter
64h	SMC SI (Vendor specific)

1. Identity Object (Class ID: 01h)

1-1. Class attribute

ID	Access rule	Description	Value
-	-	-	-

1-2. Class common service

Service code	Service name
-	-

1-3. Instance attribute

ID	Access rule	Description	Value
1	Get	Vender ID	07h
2	Get	Device Type	1Bh (27)
3	Get	Product Code	EX250-SDN1: 961h (2401) EX250-SDN1-X102: 964h (2404)
4	Get	Revision	Per unit
5	Get	Status	-
6	Get	Serial Number	Per unit
7	Get	Product Name	Valve manifold SIU

1-4. Instance common service

Service code	Service name
05h	Reset
0Eh	Get_Attribute_Single

1-5. Specific service

None.

2. Message Router Object (Class ID: 02h)

2-1. Class attribute

ID	Access rule	Description	Value
-	-	-	-

2-2. Class common service

Service code	Description
-	-

2-3. Instance attribute

ID	Access rule	Description	Value
-	-	-	-

2-4 Instance common service

Service code	Service name
-	-

2-5. Specific service

None.

3. DeviceNet® Object (Class ID: 03h)

3-1. Class attribute

ID	Access rule	Description	Value
1	Get	Revision	2

3-2. Class common service

Service code	Service name
0Eh	Get_Attribute_Single

3-3. Instance attribute

ID	Access rule	Description	Value
1	Get/Set *1	MAC ID	0-63
2	Get/Set *1	Baud Rate	0-2
3	Get/Set	BOI	0-1
4	Get/Set	Bus-off Counter	0-255
5	Get	Allocation Information	-
6	Get	MAC ID Switch Changed	0-1
7	Get	Baud Rate Switch Changed	0-1
8	Get	MAC ID Switch Value	0-63
9	Get	Baud Rate Switch Value	0-2
10	Set	Quick Connect	0-1

*1: "Set" is available in SW mode.

3-4. Instance common service

Service code	Service name
0Eh	Get_Attribute_Single
10h	Set_Attribute_Single

3-5. Specific service

Service code	Service name
4Bh	Allocate_Master/Slave_Connection_set
4Ch	Release_Group_2_Identifier_Set

4. Assembly Object (Class ID: 04h)

4-1. Class attribute

ID	Access rule	Description	Value
-	-	-	-

4-2. Class common service

Service code	Service name
-	-

4-3. Instance attribute

ID	Access rule	Description
3	Get/Set *1	Data

*1: If the instance type is input, the access rule will be Get.

4-4. Discrete Input Assembly instance

ID	Type	Description	No. of bytes	Product model
17	Input	32 Discrete input Points	4	EX250-SDN1
18	Input	32 Discrete input Points	6	EX250-SDN1-X102

The data format is shown below.

ID	Byte offset	Data							
		bit7				bit0			
17	+0	IN7	IN6	IN5	IN4	IN3	IN2	IN1	IN0
	+1	IN15	IN14	IN13	IN12	IN11	IN10	IN9	IN8
	+2	IN23	IN22	IN21	IN20	IN19	IN18	IN17	IN16
	+3	IN31	IN30	IN29	IN28	IN27	IN26	IN25	IN24
18	+0	IN7	IN6	IN5	IN4	IN3	IN2	IN1	IN0
	+1	IN15	IN14	IN13	IN12	IN11	IN10	IN9	IN8
	+2	IN23	IN22	IN21	IN20	IN19	IN18	IN17	IN16
	+3	IN31	IN30	IN29	IN28	IN27	IN26	IN25	IN24
	+4	R	R	R	R	R	R	R	R
	+5	R	R	R	R	DI_CHK *1	SOLV *1	R	R

R: Reserved

*1: Refer to the "SI unit I/O data" on page 21 this operation manual.

4-5. Solenoid Output Assembly instance

ID	Type	Description	No. of bytes
37	Output	32 Solenoid Output Points	4

The data format is shown below.

ID	Byte offset	Data							
		bit7				bit0			
37	+0	OUT7	OUT6	OUT5	OUT4	OUT3	OUT2	OUT1	OUT0
	+1	OUT15	OUT14	OUT13	OUT12	OUT11	OUT10	OUT9	OUT8
	+2	OUT23	OUT22	OUT21	OUT20	OUT19	OUT18	OUT17	OUT16
	+3	OUT31	OUT30	OUT29	OUT28	OUT27	OUT26	OUT25	OUT24

4-6. Instance common service

Service code	Service name
0Eh	Get_Attribute_Single
10h	Set_Attribute_Single

4-7. Specific service

None.

5. DeviceNet® Connection Object (Class ID: 05h)

5-1. Class attribute

ID	Access rule	Description	Value
-	-	-	-

5-2. Class common service

Service code	Service name
-	-

5-3. Instance attribute1 (Explicit message)

ID	Access rule	Description	Value
1	Get	State	-
2	Get	Instance_type	00h
3	Get	TransportClass_trigger	83h
4	Get	DeviceNet®_produced_connection_id	-
5	Get	DeviceNet®_consumed_connection_id	-
6	Get	DeviceNet®_initial_comm_characteristics	21h
7	Get	Produced_connection_size	FFFFh
8	Get	Consumed_connection_size	FFFFh
9	Get/Set	Expected_packet_rate	-
12	Get/Set	Watchdog_timeout_action	-
13	Get	Produced_connection_path_length	0
14	Get	Produced_connection_path	None
15	Get	Consumed_connection_path_length	0
16	Get	Consumed_connection_path	None
17	Get	Production_inhibit_time	0

5-4. Instance attribute2 (I/O: Poll message)

ID	Access rule	Description	Value
1	Get	State	-
2	Get	Instance_type	01h
3	Get	TransportClass_trigger	82h
4	Get	DeviceNet®_produced_connection_id	-
5	Get	DeviceNet®_consumed_connection_id	-
6	Get	DeviceNet®_initial_comm_characteristics	01h
7	Get	Produced_connection_size	04h: EX250-SDN1 06h: EX250-SDN1-X102
8	Get	Consumed_connection_size	04h
9	Get/Set	Expected_packet_rate	-
12	Get/Set	Watchdog_timeout_action	-
13	Get	Produced_connection_path_length	6
14	Get	Produced_connection_path	20h 04h 24h □□h 30h 03h 11: EX250-SDN1 12: EX250-SDN1-X102
15	Get	Consumed_connection_path_length	6
16	Get	Consumed_connection_path	20h 04h 24h 25h 30h 03h
17	Get	Production_inhibit_time	-

5-5. Instance common service

Service code	Service name
0Eh	Get_Attribute_Single
10h	Set_Attribute_Single

6. Discrete Input Point Object (Class ID: 08h)

6-1 Class attribute

ID	Access rule	Description	Data type	Value
1	Get	Revision	UINT	2

6-2. Class common service

Service code	Service name
0Eh	Get_Attribute_Single

6-3. Instance attribute

ID	Access rule	Description	Data type	Value
3	Get	Value	BooL	0: OFF 1: ON
4	Get	Status	BooL	0: Input block fuse is normal 1: Input block fuse is broken

6-4. Instance common service

Service code	Service name
0Eh	Get_Attribute_Single

6-5 Specific service

None.

7. Discrete Output Point Object (Class ID: 09h)

7-1. Class attribute

ID	Access rule	Description	Value
-	-	-	-

7-2. Class common service

Service code	Service name
-	-

7-3. Instance attribute

ID	Access rule	Description	Value
3	Get/Set	Value	0: OFF 1: ON
4	Get	Status	0: Normal 1: Valve power supply failure
5	Get/Set *1	Fault Action	0: Fault set value 1: Output held
6	Get/Set *1	Fault Value	0: CLEAR 1: SET
7	Get/Set *1	Idle Action	0: Idle set value 1: Output held
8	Get/Set *1	Idle Value	0: CLEAR 1: SET

*1: EEPROM holding data

7-4. Instance common service

Service code	Service name
0Eh	Get_Attribute_Single
10h	Set_Attribute_Single

7-5. Specific service

None.

8. Parameter Object (Class ID: 0Fh)

8-1. Class attribute

ID	Access rule	Description	Value
2	Get	Max Instance	4
8	Get	Parameter Class Descriptor	1
9	Get	Configuration Assembly Instance	0

8-2. Class common service

Service code	Service name
0Eh	Get_Attribute_Single

8-3. Instance attribute 1: SOLV Status

ID	Access rule	Description	Value
1	Get	Parameter Value	1: Valve power supply voltage is normal 0: Valve power supply voltage is abnormal
2	Get	Link Path Size	6
3	Get	Link Path	20h 64h 24h 01h 30h 64h
4	Get	Descriptor	30h
5	Get	Data Type	C1h
6	Get	Data Size	1

8-4. Instance attribute 3: IU Fuse Status

ID	Access rule	Description	Value
1	Get	Parameter Value	1: Input block fuse is normal 0: Input block fuse is broken
2	Get	Link Path Size	6
3	Get	Link Path	20h 64h 24h 01h 30h 67h
4	Get	Descriptor	30
5	Get	Data Type	C1h
6	Get	Data Size	1

8-5. Instance attribute 5: HOLD/Clear (Timeout)

ID	Access rule	Description	Value
1	Get/Set	Parameter Value	0: Switch setting valid 1: Fault action valid
2	Get	Link Path Size	6
3	Get	Link Path	20h 64h 24h 01h 30h 68h
4	Get	Descriptor	20h
5	Get	Data Type	C1h
6	Get	Data Size	1

8-6. Instance attribute 6: HOLD/Clear (Delete)

ID	Access rule	Description	Value
1	Get	Parameter Value	0: Switch setting valid 1: Fault action valid
2	Get	Link Path Size	6
3	Get	Link Path	20h 64h 24h 01h 30h 69h
4	Get	Descriptor	20h
5	Get	Data Type	C1h
6	Get	Data Size	1

8-7. Instance common service

Service code	Service name
0Eh	Get_Attribute_Single
10h	Set_Attribute_Single

8-8. Specific service

None

9. SMC SI Object (Class ID: 64h)

9-1. Class attribute

ID	Access rule	Description	Value
-	-	-	-

9-2 Class common service

Service code	Service name
-	-

9-3. Instance attribute

ID	Access rule	Description	Value
100	Get	SOLV Status	1: Output power supply voltage is normal 0: Output power supply voltage is abnormal
103	Get	IU Fuse Status	1: Input block fuse is normal 0: Input block fuse is broken
104	Get/Set	Hold/Clear (Timeout)	0: Switch setting valid 1: Fault action valid
105	Get/Set	Hold/Clear (Delete)	0: Switch setting valid 1: Fault action valid

9-4 Instance common service

Service code	Service name
0Eh	Get_Attribute_Single
10h	Set_Attribute_Single

9-5 Specific service

None.

Maintenance

Replacing the SI unit

- Remove the screws from the end plate and release the connection with the valve unit.
- Replace the SI unit (There is no need to remove the tie rod).
Re-mount the end plate that was removed, and tighten the screws to the specified tightening torque.
(0.6 N•m)

Precautions for maintenance

- (1) Turn off the power supply completely.
- (2) Check that there is no foreign matter inside the unit.
- (3) Check that there is no damage and no foreign matter on the gasket.
- (4) Tighten the screws to the specified torque.

If the unit is not assembled correctly, this may cause product failure due to foreign matter such as liquid and dust which may get into the unit.

Assembly and disassembly of the SI unit

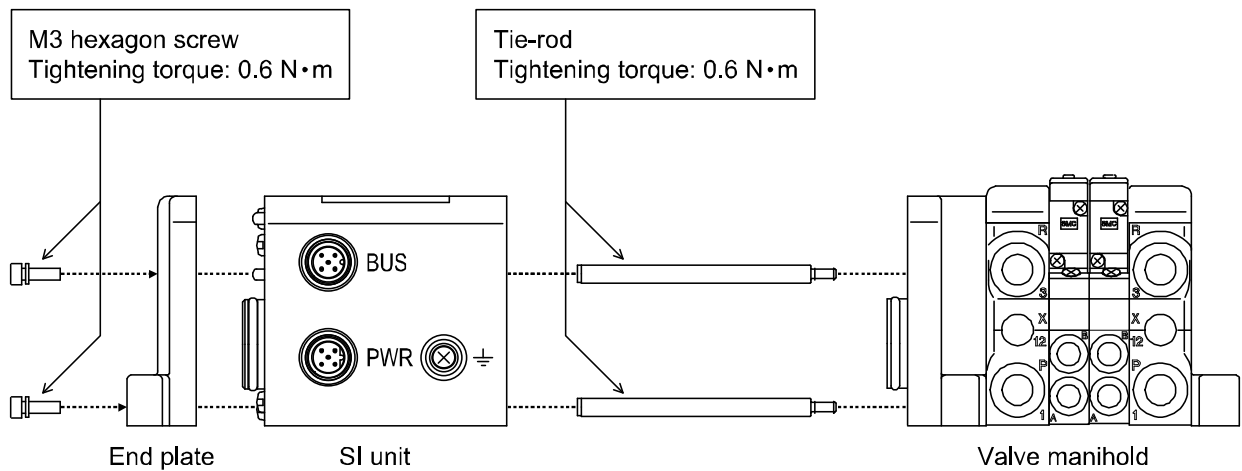

Troubleshooting

Troubleshooting flow chart

When any failure occurs with the SI unit, the following chart can be used to identify the cause of the failure.

→ Yes
 ...→ No

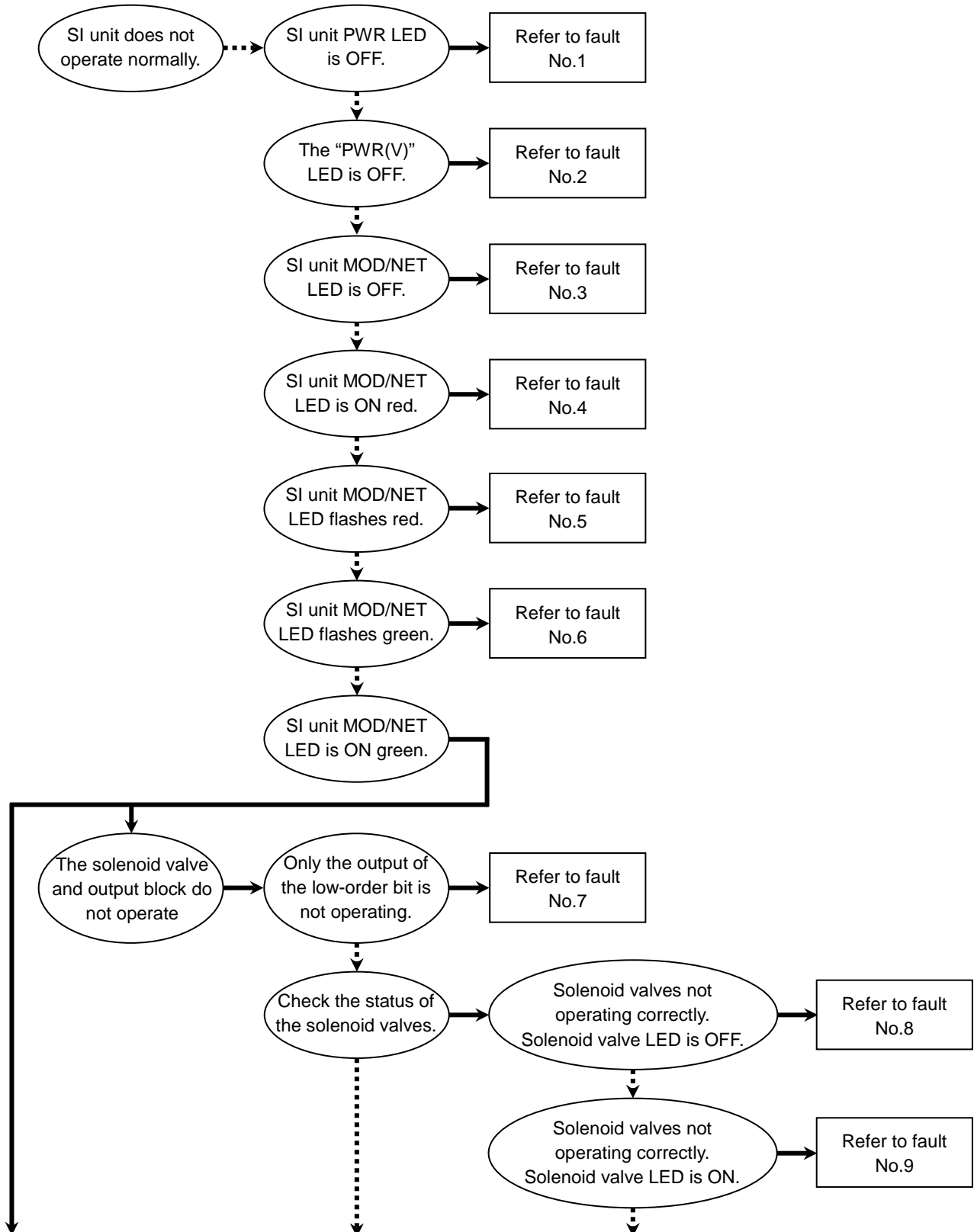

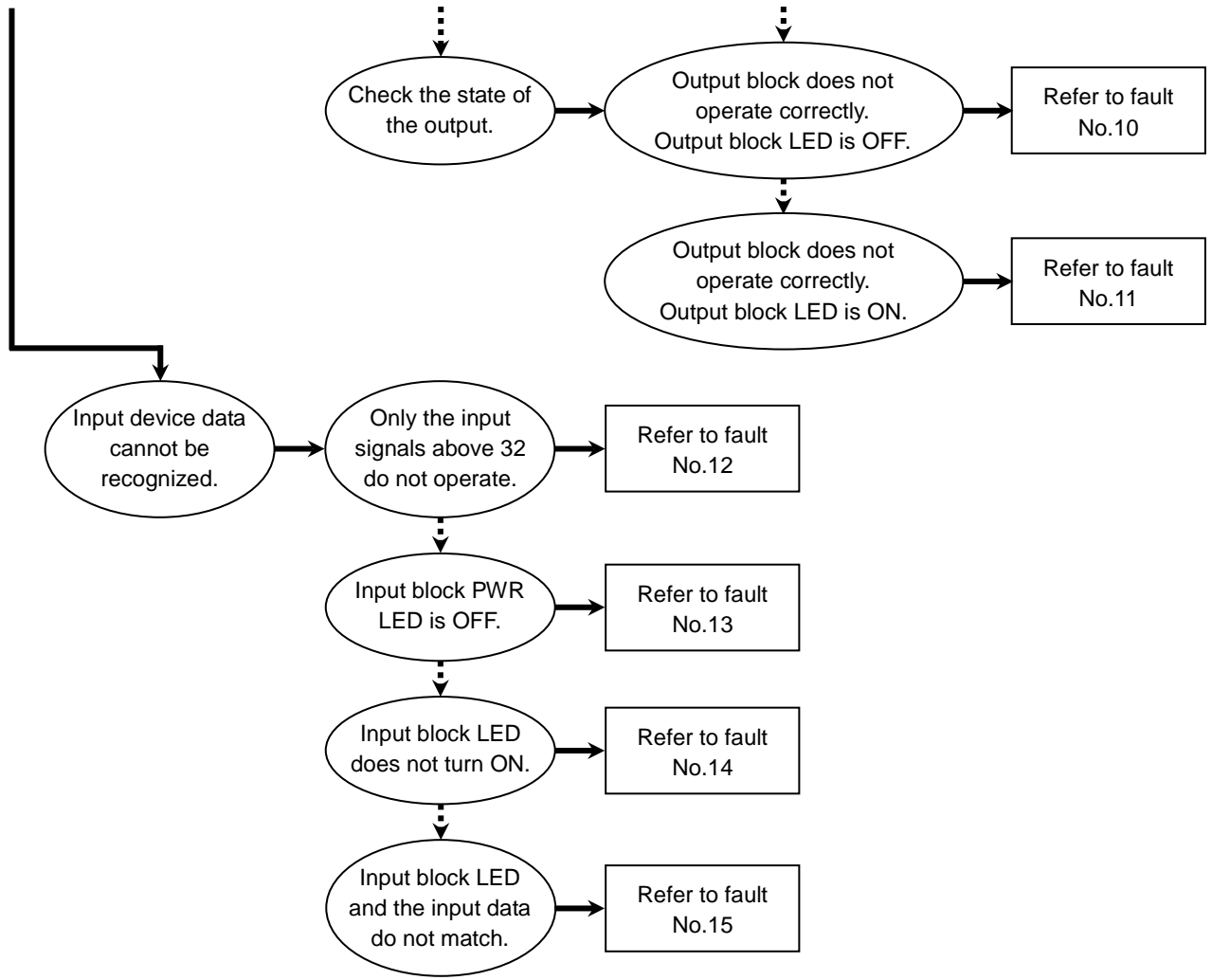

Failure Problem

Fault No.1

Problem	Possible cause	Investigation method	Countermeasures
SI unit PWR LED is OFF	Incorrect wiring of the power supply for DeviceNet® communication	Check the power supply cable connections and check for broken wires.	Re-wire the DeviceNet® cable. (Replace the cable if it is damaged).
			Correct the wiring of the power supply cable.
	Failure of the power supply for DeviceNet® communication	Check the supply voltage of the DeviceNet® power supply.	Supply 11 to 25 VDC to the DeviceNet® power supply.

Fault No.2

Problem	Possible cause	Investigation method	Countermeasures
SI unit PWR (V) LED is OFF	Wiring of the solenoid valve power supply is defective	Check the power supply cable connections and check for broken wires.	Review the connection condition of the power supply cable. (If the cable is broken, replace it with new one.)
			Review the wiring condition of the power supply cable.
	Solenoid valve power supply failure	Check proper supply voltage of solenoid valve power supply.	Supply 22.8 to 26.4 VDC to the power supply for the solenoid valve.

*: PWR (V) LED is OFF regardless of the solenoid valve power supply when the DeviceNet® communication power supply is not supplied (when the SI unit PWR_LED is OFF).

EX250-SDN1 disconnects the I/O connection when the solenoid valve power supply decreases.

EX250-SDN1-X102 does not disconnect the I/O connection.

Fault No.3

Problem	Possible cause	Investigation method	Countermeasures
SI unit MOD/NET LED is OFF	Incorrect wiring of the DeviceNet® cable	Check the power supply cable connections and check for broken wires.	Tighten the DeviceNet® cable connection. (If the cable has a broken wire, replace the cable).
			Correct the wiring of the DeviceNet® cable.
	Failure of the power supply for the DeviceNet® master station	Check the wiring of the power supply for the DeviceNet® master station.	Check the power supply for the DeviceNet® master station.

Fault No.4

Problem	Possible cause	Investigation method	Countermeasures
SI unit MOD/NET LED is ON red	MAC ID duplication error	Check that there is no MAC ID duplication between the master and slave.	Correct the MAC ID settings.
	BUS OFF error	Check that the length of the communication cable is suitable for the communication speed, check for terminators at both ends, and check that the special cable for DeviceNet® is used.	Correct the wiring and settings.
		Check that there is no equipment or high voltage cables which generates noise around the communication and power supply cables.	Separate the communication and power supply cables away from noise sources.
		Check the power supply cable connections and check for broken wires. Confirm that repeated bending stress or pulling force which causes open wire is not applied to the cable.	Correct the connection of the DeviceNet® cable.
		Confirm that the SI unit communication speed setting and the communication speed settings of the master and slave are the same.	Correct the communication speed settings.
	Failure of the communication device	-	Replacement of the SI unit.

Fault No.5

Problem	Possible cause	Investigation method	Countermeasures
SI unit MOD/NET LED is flashing red	I/O connection time out	Check that the length of the communication cable is suitable for the communication speed, check for terminators at both ends, and check that the special cable for DeviceNet® is used.	Correct the wiring and settings.
		Check that there is no equipment or high voltage cables which generates noise around the communication and power supply cables.	Separate the communication and power supply cables away from noise sources.
		Check the DeviceNet® cable connections and check for broken wires. Confirm that repeated bending stress or pulling force which causes open wire is not applied to the cable.	Correct the connection of the DeviceNet® cable.
		Confirm that power is supplied to the master station.	Supply power to the master station correctly.

Fault No.6

Problem	Possible cause	Investigation method	Countermeasures
SI unit MOD/NET LED is flashing green	Incorrect wiring of the power supply for DeviceNet® communication	Check the DeviceNet® cable connections and check for broken wires.	Tighten the DeviceNet® cable connection. (If the cable has a broken wire, replace the cable).
			Correct the wiring of the DeviceNet® cable.
	I/O connection stand-by (on-line status)	If the network is using a scan list, check that the slave is registered correctly into the scan list.	Correct the setting of the scan list.

Fault No.7

Problem	Possible cause	Investigation method	Countermeasures
Only the output of the low-order bit is not operating	No. of solenoids has exceeded the allowable number	Check that the number of solenoids has not exceeded the allowable number. The allowable number depends on the SI unit model and valve series. Number of solenoids that can be mounted: SY/SV series: 32 points VQC/S0700 series: 24 points	Change the number of solenoids to be within the specification.

Fault No.8

Problem	Possible cause	Investigation method	Countermeasures
Solenoid valves do not operate correctly, solenoid valve LED is OFF	Defective connection between the SI unit and solenoid valve manifold	Check that the screws which connect the SI unit and the solenoid valve are not loose.	Tighten the screws while holding the SI unit and the solenoid valve manifold so that there is no gap between them. Tighten the screws to the specified torque.
	Polarity of the solenoid valve and the SI unit output are not compatible	Check that the solenoid valve polarity specification and output polarity of the SI unit are compatible.	Use a solenoid valve polarity compatible with the output polarity of the SI unit.
	Solenoid valve failure	Refer to the troubleshooting of the solenoid valve.	Refer to the troubleshooting of the solenoid valve.

Fault No.9

Problem	Possible cause	Investigation method	Countermeasures
Solenoid valves do not operate correctly, solenoid valve LED is ON	Solenoid valve failure	Refer to the troubleshooting of the solenoid valve.	Refer to the troubleshooting of the solenoid valve.

Fault No.10

Problem	Possible cause	Investigation method	Countermeasures
Output block does not operate correctly, output block LED is OFF	Defective connection between the SI unit and output block	Check that the screws which connect the SI unit and output block are not loose.	Confirm grounding to improve the anti-noise performance of the SI unit.
	Polarity of the output block and SI unit output are not compatible	Check that the output block polarity specification and output polarity of the SI unit are compatible. <ul style="list-style-type: none"> •EX500-Q002 (NPN output) ⇔EX9-OET2/-OEP2 •EX500-Q102 (PNP output) ⇔EX9-OET1/-OEP1 	Use an output block polarity compatible with the output polarity of the SI unit.
	(When EX9-OEP1/-OEP2 is used) Defective connection of the power block	Check if a power block is used, and check that the position of the power block is correct.	Install the power block on the SI unit side of the output block (EX9-OEP1/-OEP2). (Refer to the operation manual of EX9 series general purpose output block).
	Failure of SI unit, power block or output block	Check that the power block and output block are operating correctly. Replace the power block or output block and check the operation.	Replace the power block or output block and check the operation.

Fault No.11

Problem	Possible cause	Investigation method	Countermeasures
Output block does not operate correctly, output block LED is ON	Defective connection between the output block and load device	Check the connection and wiring (pin layout) between the load device and the output block. Check for broken wires.	Tighten the cable connection. (If the cable has a broken wire, replace the cable).
			Rectify the wire layout of the cable for output entry.
	Output block failure	Check that the output block is operating correctly. Replace the output block and check the operation.	Replace the output block and check the operation.

Fault No.12

Problem	Possible cause	Investigation method	Countermeasures
Only the input signals above 32 do not operate	The total number of input block inputs connected has exceeded the maximum allowed	Check that the total number of inputs is 32 or less.	Remove unused extra inputs from the manifold, and ensure there are 32 inputs or less.

Fault No.13

Problem	Possible cause	Investigation method	Countermeasures
Input block PWR LED is OFF	Failure of the power supply for input block of the product	Check the power supply voltage for input block of the product.	Supply 24V DC +/-10% to the power supply for the input block.
	Defective connection between the SI unit and input block	Check that the bolts which connect the SI unit and input block are not loose.	Tighten the bolts while holding the SI unit and the input block so that there is no gap between them. The bolts should be tightened with the specified tightening torque. (Tightening torque: 0.6 N•m)
	Input block fuse blown/broken *1	Check for broken fuse of the input block.	Remove the causes of the broken fuse (e.g. short-circuit) and replace the fuse.
	Liquid such as water has entered the product	Confirm that all unused connectors of the input block have a waterproof cap fitted.	If liquid has entered the product, replace the input block.
	Input block failure	Check that the input block is operating correctly.	Replace the input block.

*1: EX250-SDN1 disconnects the I/O connection when fuse of the input block breaks.
EX250-SDN1-X102 does not disconnect the I/O connection.

Fault No.14

Problem	Possible cause	Investigation method	Countermeasures
Input block LED does not turn ON	Defective connection between the SI unit and input block	Check that the screws which connect the SI unit and input block are not loose.	Tighten the screws while holding the SI unit and the input block so that there is no gap between them. Tighten the screws to the specified torque.
	Polarity of the input block and input device are not compatible	Check that the polarity of the input block and the input device are compatible.	Use an input device polarity compatible with the polarity of the input block.
	Defective connection between the input block and input device	Check the input device connection and wiring (pin layout) and check for broken wires.	Tighten the cable connection. (If the cable has a broken wire, replace the cable).
			Rectify the wiring of the input device cable.
Input block failure	Check that the input block is operating correctly.	Replace the input unit and check the operation.	

Fault No.15

Problem	Possible cause	Investigation method	Countermeasures
Input block LED and the input data do not match	Defective connection between the SI unit and input block	Check that the screws which connect the SI unit and input block are not loose.	Tighten the screws while holding the SI unit and the input block so that there is no gap between them. Tighten the screws to the specified torque.
	Failure of the SI unit or input block	Check that the SI unit and input block are operating correctly.	Replace the SI unit or input block and check the operation.

Specification

■ Specifications

General specification

Item	Specifications
Ambient temperature	-10 to +50 °C
Ambient humidity	35 to 85% RH (no condensation)
Storage temperature	-20 to +60 °C
Withstand voltage	500 VAC applied for 1 minute
Insulation resistance	500 VDC, 10 MΩ or more
Enclosure	IP67
Standard	CE marked (EMC directive, RoHS directive), UL (CSA)
Weight	250 g or less

Electric specifications

Item	Specifications	
Applicable system	DeviceNet® Release2.0	
Power supply voltage range and current consumption	SI unit power supply (V) and current consumption	Conforms to the DeviceNet® specifications (11 to 25 VDC) 100 mA or less
	Input block power supply (V) and current consumption	19.2 to 28.8 VDC Depends on the number of blocks and sensor specifications: Max. 1 A
	Solenoid valve power supply (V) and current consumption	22.8 to 26.4 VDC (power drop alarm at approx. 19 VDC) Depends on the number of solenoid valve stations: Max. 2 A
Solenoid valve connection specification	Output method	Source/PNP (negative common)
	Connected load	Solenoid valve with surge voltage suppressor of 24 VDC and 1.5 W or less (manufactured by SMC)
	Insulation type	Photo coupler insulation type
	Residual voltage	0.3 VDC or less

Communication specification

Item	Specifications	
	EX250-SDN1	EX250-SDN1-X102
MAC ID set range	0 to 63 (MAC ID information is maintained even when the power supply is cut if it is set either by the DIP switch or via communication network).	
Baud rate (communication speed)	500 kbps, 250 kbps, 125 kbps (Communication information is maintained even when the power supply is cut if it is set either by the DIP switch or via communication network).	
Slave type	Group 2 Only Server	
Configuration	T branch type, Multi drop type	
Device type	27	
Product code	2401	2404
Setting file: EDS file (Please download from SMC website)	ex250-sdn1_44_v□.eds	ex250-sdn1_64_v□.eds
Vendor ID	7	
Consumed Connection Size (No. of bytes received)	4 (Polled I/O Connection, 4 bytes occupied)	4 (Polled I/O Connection, 4 bytes occupied)
Produced Connection Size (No. of bytes sent)	4 (Polled I/O Connection, 4 bytes occupied)	6 (Polled I/O Connection, 6 bytes occupied)
Corresponding messages	Polled command (I/O message, Explicit message)	
Corresponding function	QuickConnect™	

■Dimensions

○EX250-SDN1/EX250-SDN1-X102

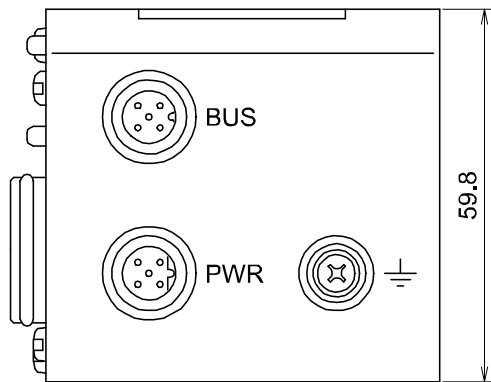
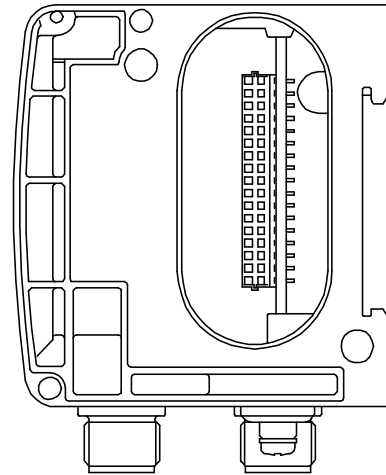
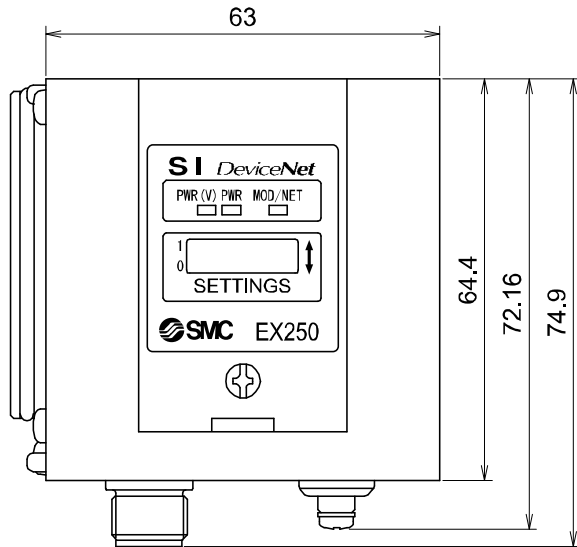

Option

1. DeviceNet® communication connector cable

How to order

PCA-1557633

• Cable specification

1557633	M12 Socket connector: 5 m SPEEDCON
1557646	M12 Plug connector: 5 m SPEEDCON

Cable O.D.		φ6.7
Nominal cross section area	Power line	0.33 mm ² / AWG22
	Signal line	0.2 mm ² / AWG24
Wire diameter	Power line	1.4 mm
	Signal line	2.05 mm
Minimum bending radius		67 mm (fixed)

2. DeviceNet® communication assembly type connector

How to order

PCA-1557659

• Cable specification

1557659	M12 Plug connector
1557662	M12 Socket connector

Wire diameter	4.0 to 8.0 mm
Wire gauge (standard wire cross section)	0.14 to 0.5 mm ² / AWG26 to 20

3. DeviceNet® communication terminating resistor

How to order

PCA-1557675

• Terminator specification

1557675	M12 Plug connector type
---------	-------------------------

4. Power supply connector cable

How to order

EX9-AC 010-1

• Cable length

010	1 m
030	3 m
050	5 m

Cable O.D.	φ6.6
Nominal cross section area	0.3 mm ² /AWG22
Wire diameter	1.65 mm
Minimum bending radius	40 mm (fixed)

5. Spare fuse (for input block)

How to order

EX9-FU 05

• Rating

05	0.5 A
----	-------

6. Electrical entry connector cable

How to order

EX9-AC 010-7

• Cable length

010	1 m
030	3 m

Cable O.D.	φ6.6
Nominal cross section area	0.3 mm ² /AWG22
Wire diameter	1.65 mm
Minimum bending radius	40 mm (fixed)

7. Power supply connector cable (for power supply to the power block)

How to order

EX9-AC 002-3

• Cable length

002	0.2 m
-----	-------

Cable O.D.	φ6.6
Minimum bending radius	40 mm (fixed)

8. Input block relay connector cable

How to order

PCA-1557769

• Cable specification

1557769	M12, 4-pin connector: 3 m
1557772	M8, 3-pin connector: 3 m

M12 connector

Cable O.D.	φ4.7
Minimum bending radius	47 mm (fixed)

M8 connector

Cable O.D.	φ4.4
Minimum bending radius	44 mm (fixed)

9. Input block assembly type connector

How to order

PCA-1557730

• Cable specification

1557730	M8, 3-pin Plug connector (AWG26 to 22)
1557743	M12, 4-pin Plug connector (AWG26 to 22)
1557756	M12, 4-pin Plug connector (AWG22 to 18)

10. End plate (on the input block side)

How to order

EX250-EA 1

• Mounting

1	Direct mounting
2	DIN rail mounting

Accessory

Hexagon socket head cap screw (2 pcs.)

EX250-EA1

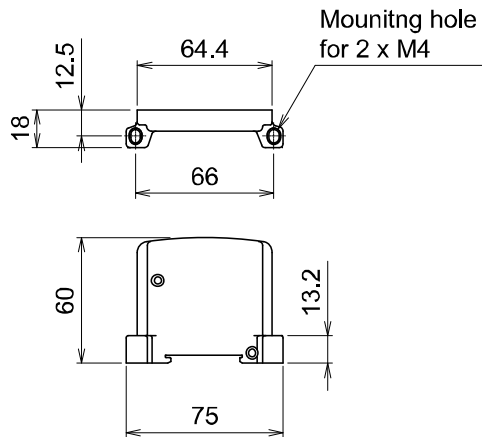

EX250-EA2

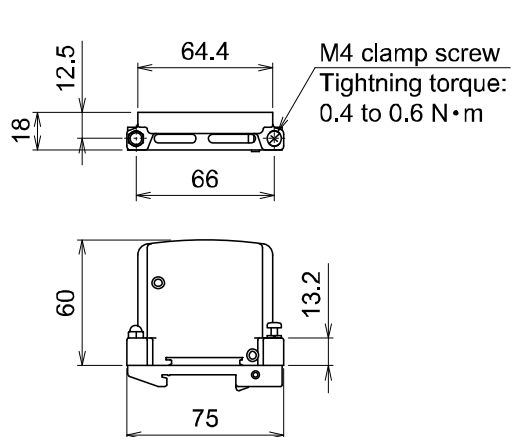

11. End plate R (on the output block side)

How to order

EX9-EA 03

• Mounting

03	Direct mounting
04	DIN rail mounting

EX9-EA03

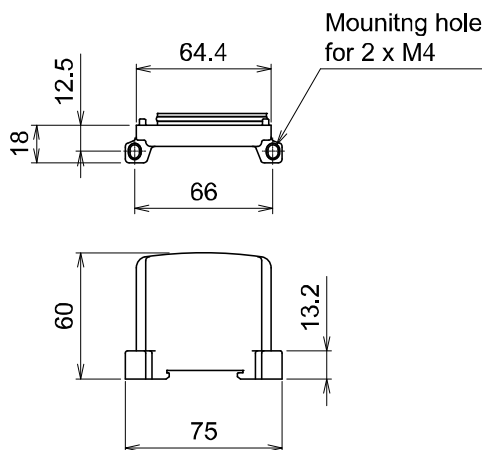

EX9-EA04

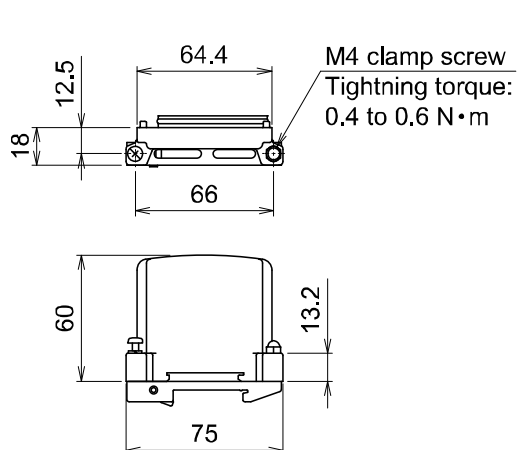

12. Waterproof cap

Mount this to the unused ports of the input block, output block and power block. Proper use of the waterproof cap enables the enclosure to achieve IP67 specification. (The power block is provided with the product.)

How to order

EX9-AW

• Connector specification

ES	M8 connector (socket) / 10 pcs.
TS	M12 connector (socket) / 10 pcs.



Note

Tighten the waterproof caps to the tightening torque specified. (M8: 0.05 N•m, M12: 0.1 N•m)

Revision history

C: All revised contents.
D: Modified errors in text.
E: Limited warranty and Disclaimer are added.
F: Contents are added. [July 2017]
G: Contents are added. [January 2021]
H: Contents revised in several places.
[December 2021]

SMC Corporation

4-14-1, Sotokanda, Chiyoda-ku, Tokyo 101-0021 JAPAN
Tel: + 81 3 5207 8249 Fax: +81 3 5298 5362
URL <https://www.smcworld.com>

Note: Specifications are subject to change without prior notice and any obligation on the part of the manufacturer.

DeviceNet® is registered trademark of ODVA, Inc.

© 2011-2021 SMC Corporation All Rights Reserved

