



Operation Manual

SI Unit

PRODUCT NAME

EX245-SPN1

EX245-SPN2

MODEL / Series

Digital Input Module

PRODUCT NAME

EX245-DX1

MODEL / Series

Digital Output Module

PRODUCT NAME

EX245-DY1

MODEL / Series

End Plate

PRODUCT NAME

EX245-EA2-1

EX245-EA2-2

MODEL / Series

SMC Corporation

Contents

Safety Instructions	4
1. Product Summary	10
1.1. Features	10
1.2. Structure	11
2. General Specifications	12
3. Installation	13
3.1. Mounting	13
3.2. Wiring	15
4. Commissioning	20
4.1. Configuration	20
4.2. Parameterisation	23
5. Diagnosis	26
5.1. Diagnostics data on I/O mapping	26
5.2. Maintenance alarm for the Fibre-optic cables	30
6. SI Unit	31
6.1. Parts and description	31
6.2. Specifications	32
6.3. Process data for valves	33
6.4. LED indicators	34
6.5. Block diagram	37
7. Digital Input Module - EX245-DX1	39
7.1. Parts and description	39
7.2. Specifications	40
7.3. Wiring	41
7.4. Process data	41
7.5. LED indicators	42
7.6. Block diagram	43
8. Digital Output Module - EX245-DY1	44
8.1. Parts and description	44
8.2. Specifications	45
8.3. Wiring	46
8.4. Process data	46
8.5. LED indicators	47
8.6. Block diagram	48

9. End Plate - EX245-EA2-1/2	49
9.1. Parts and description	49
9.2. Specifications	50
10. Accessories	51
10.1. Markers	51
10.2. Y Connector	52
10.3. Seal cap	54
10.4. Joint pack	56
11. Dimensions	57
11.1. The Input/Output Modules Manifold	57
12. Troubleshooting	58
12.1. EX245-SPN1/SPN2	58
12.2. EX245-DX1	60
12.3. EX245-DY1	60



Safety Instructions

These safety instructions are intended to prevent hazardous situations and/or equipment damage. These instructions indicate the level of potential hazard with the labels of "Caution", "Warning" or "Danger". They are all important notes for safety and must be followed in addition to International Standards (ISO/IEC)*1), and other safety regulations.

*1) ISO 4414: Pneumatic fluid power -- General rules relating to systems.

ISO 4413: Hydraulic fluid power -- General rules relating to systems.

IEC 60204-1: Safety of machinery -- Electrical equipment of machines. (Part 1: General requirements)

ISO 10218: Manipulating industrial robots -Safety.

etc.



Caution

Caution indicates a hazard with a low level of risk which, if not avoided, could result in minor or moderate injury.



Warning

Warning indicates a hazard with a medium level of risk which, if not avoided, could result in death or serious injury.



Danger

Danger indicates a hazard with a high level of risk which, if not avoided, will result in death or serious injury.

Warning

1. The compatibility of the product is the responsibility of the person who designs the equipment or decides its specifications.

Since the product specified here is used under various operating conditions, its compatibility with specific equipment must be decided by the person who designs the equipment or decides its specifications based on necessary analysis and test results.

The expected performance and safety assurance of the equipment will be the responsibility of the person who has determined its compatibility with the product.

This person should also continuously review all specifications of the product referring to its latest catalog information, with a view to giving due consideration to any possibility of equipment failure when configuring the equipment.

2. Only personnel with appropriate training should operate machinery and equipment.

The product specified here may become unsafe if handled incorrectly.

The assembly, operation and maintenance of machines or equipment including our products must be performed by an operator who is appropriately trained and experienced.

3. Do not service or attempt to remove product and machinery/equipment until safety is confirmed.

1. The inspection and maintenance of machinery/equipment should only be performed after measures to prevent falling or runaway of the driven objects have been confirmed.

2. When the product is to be removed, confirm that the safety measures as mentioned above are implemented and the power from any appropriate source is cut, and read and understand the specific product precautions of all relevant products carefully.

3. Before machinery/equipment is restarted, take measures to prevent unexpected operation and malfunction.

4. Contact SMC beforehand and take special consideration of safety measures if the product is to be used in any of the following conditions.

1. Conditions and environments outside of the given specifications, or use outdoors or in a place exposed to direct sunlight.

2. Installation on equipment in conjunction with atomic energy, railways, air navigation, space, shipping, vehicles, military, medical treatment, combustion and recreation, or equipment in contact with food and beverages, emergency stop circuits, clutch and brake circuits in press applications, safety equipment or other applications unsuitable for the standard specifications described in the product catalog.

3. An application which could have negative effects on people, property, or animals requiring special safety analysis.

4. Use in an interlock circuit, which requires the provision of double interlock for possible failure by using a mechanical protective function, and periodical checks to confirm proper operation.



Safety Instructions

Caution

1. The product is provided for use in manufacturing industries.

The product herein described is basically provided for peaceful use in manufacturing industries. If considering using the product in other industries, consult SMC beforehand and exchange specifications or a contract if necessary. If anything is unclear, contact your nearest sales branch.

Limited warranty and Disclaimer/Compliance Requirements

The product used is subject to the following "Limited warranty and Disclaimer" and "Compliance Requirements".

Read and accept them before using the product.

Limited warranty and Disclaimer

1. The warranty period of the product is 1 year in service or 1.5 years after the product is delivered, whichever is first.*2)

Also, the product may have specified durability, running distance or replacement parts. Please consult your nearest sales branch.

2. For any failure or damage reported within the warranty period which is clearly our responsibility, a replacement product or necessary parts will be provided.

This limited warranty applies only to our product independently, and not to any other damage incurred due to the failure of the product.

3. Prior to using SMC products, please read and understand the warranty terms and disclaimers noted in the specified catalog for the particular products.

***2) Vacuum pads are excluded from this 1 year warranty.**

A vacuum pad is a consumable part, so it is warranted for a year after it is delivered.

Also, even within the warranty period, the wear of a product due to the use of the vacuum pad or failure due to the deterioration of rubber material are not covered by the limited warranty.

Compliance Requirements

1. The use of SMC products with production equipment for the manufacture of weapons of mass destruction (WMD) or any other weapon is strictly prohibited.

2. The exports of SMC products or technology from one country to another are governed by the relevant security laws and regulation of the countries involved in the transaction. Prior to the shipment of a SMC product to another country, assure that all local rules governing that export are known and followed.

Operator

- ◆ This operation manual is intended for those who have knowledge of machinery using pneumatic equipment, and have sufficient knowledge of assembly, operation and maintenance of such equipment. Only those persons are allowed to perform assembly, operation and maintenance.
- ◆ Read and understand this operation manual carefully before assembling, operating or providing maintenance to the product.

■ Safety Instructions

Warning

- Do not disassemble, modify (including changing the printed circuit board) or repair.
An injury or failure can result.
- Do not operate or set with wet hands.
This may lead to an electric shock.
- Do not operate the product outside of the specifications.
Do not use for flammable or harmful fluids.
Fire, malfunction, or damage to the product can result.
Verify the specifications before use.
- Do not operate in an atmosphere containing flammable or explosive gases.
Fire or an explosion can result.
This product is not designed to be explosion proof.
- If using the product in an interlocking circuit:
 - Provide a double interlocking system, for example a mechanical system.
 - Check the product regularly for proper operation.Otherwise malfunction can result, causing an accident.
- The following instructions must be followed during maintenance:
 - Turn off the power supply.
 - Stop the air supply, exhaust the residual pressure and verify that the air is released before performing maintenance.Otherwise an injury can result.

Caution

- When handling the unit or assembling/replacing units:
 - Do not touch the sharp metal parts of the connector or plug for connecting units.
 - Take care not to hit your hand when disassembling the unit.
The connecting portions of the unit are firmly joined with seals.
 - When joining units, take care not to get fingers caught between units.
An injury can result.

- After maintenance is complete, perform appropriate functional inspections.
Stop operation if the equipment does not function properly.
Safety cannot be assured in the case of unexpected malfunction.

- Provide grounding to assure the noise resistance of the Fieldbus system.
Individual grounding should be provided close to the product with a short cable.

■ **NOTE**

- Follow the instructions given below when designing, selecting and handling the product.
 - The instructions on design and selection (installation, wiring, environment, adjustment, operation, maintenance, etc.) described below must also be followed.
 - *Product specifications
 - Use the specified voltage.
Otherwise failure or malfunction can result.
 - Reserve a space for maintenance.
Allow sufficient space for maintenance when designing the system.
 - Do not remove any nameplates or labels.
This can lead to incorrect maintenance, or misreading of the operation manual, which could cause damage or malfunction to the product.
It may also result in non-conformity to safety standards.
 - Beware of inrush current when the power supply is turned on.
Some connected loads can apply an initial charge current which will activate the over current protection function, causing the unit to malfunction.

●Product handling

*Installation

- Do not drop, hit or apply excessive shock to the product.

Otherwise damage to the product can result, causing malfunction.

- Tighten to the specified tightening torque.

If the tightening torque is exceeded the mounting screws may be broken.

IP65 protection cannot be guaranteed if the screws are not tightened to the specified torque.

- If a large manifold valve is mounted, lift the unit so that stress is not applied to the connecting part while transporting.

The stress may cause breakage of the connecting part. The unit may become very heavy depending on the combination. Transportation/installation shall be performed by multiple operators.

- Never mount a product in a location that will be used as a foothold.

The product may be damaged if excessive force is applied by stepping or climbing onto it.

*Wiring

- Avoid repeatedly bending or stretching the cables, or placing heavy load on them.

Repetitive bending stress or tensile stress can cause breakage of the cable.

- Wire correctly.

Incorrect wiring can break the product.

- Do not perform wiring while the power is on.

Otherwise damage to the SI Unit and/or input or output module can result, causing malfunction.

- Do not route wires and cables together with power or high voltage cables.

Otherwise the SI Unit and/or input or output module can malfunction due to interference of noise and surge voltage from power and high voltage cables to the signal line.

Route the wires (piping) of the SI Unit and/or input or output module separately from power or high voltage cables.

- Confirm proper insulation of wiring.

Poor insulation (interference from another circuit, poor insulation between terminals, etc.) can lead to excess voltage or current being applied to the product, causing damage.

- Take appropriate measures against noise, such as using a noise filter, when the Fieldbus system is incorporated into equipment.

Otherwise noise can cause malfunction.

*Environment

- Select the proper type of protection according to the environment of operation.

IP65 protection is achieved when the following conditions are met.

(1)The EX245-SPN1/SPN2 and/or input or output module are connected properly with power/fieldbus cable with Push Pull connector and I/O device cable with M12 connector.

(2)Suitable mounting of each unit and manifold valve.

(3)Be sure to fit a waterproof cap on any unused connectors.

If using in an environment that is exposed to water splashes, please take measures such as using a cover.

Do not use in an environment where moisture or water vapor are present. Otherwise failure and malfunction can result.

- Do not use in a place where the product could be splashed by oil or chemicals.

If the product is to be used in an environment containing oils or chemicals such as coolant or cleaning solvent, even for a short time, it may be adversely affected (damage, malfunction etc.).

- Do not use the product in an environment where corrosive gases or fluids could be splashed.

Otherwise damage to the product and malfunction can result.

- Do not use in an area where surges are generated.

If there is equipment generating large surge near the unit (magnetic type lifter, high frequency inductive furnace, welding machine, motor, etc.), this can cause deterioration of the internal circuitry element of the unit or result in damage. Take measures against the surge sources, and prevent the lines from coming into close contact.

- When a surge-generating load such as a relay, valve or lamp is driven directly, use a product with a built-in surge absorbing element.
Direct drive of a load generating surge voltage can damage the product.
- The product is CE marked, but not immune to lightning strikes. Take measures against lightning strikes in the system.
- Prevent foreign matter such as dust or wire debris from getting inside the product.
- Mount the product in a place that is not exposed to excessive vibration or impact.
Otherwise failure or malfunction can result.
- Do not use the product in an environment that is exposed to temperature cycle.
Heat cycles other than ordinary changes in temperature can adversely affect the inside of the product.
- Do not expose the product to direct sunlight.
If using in a location directly exposed to sunlight, shade the product from the sunlight.
Otherwise failure or malfunction can result.
- Keep within the specified ambient temperature range.
Otherwise malfunction can result.
- Do not operate close to a heat source, or in a location exposed to radiant heat.
Otherwise malfunction can result.

*Adjustment and Operation

- Perform settings suitable for the operating conditions.
Incorrect setting can cause operation failure.
For details of each setting, refer to the SI Unit Operation Manual.
- Please refer to the IO Controller manufacturer's manual etc. for details of programming and addresses.
For the IO Controller protocol and programming refer to the relevant manufacturer's documentation.

*Maintenance

- Turn off the power supply, stop the supplied air, exhaust the residual pressure and verify the release of air before performing maintenance.
There is a risk of unexpected malfunction.
- Perform regular maintenance and inspections.
There is a risk of unexpected malfunction.
- After maintenance is complete, perform appropriate functional inspections.
Stop operation if the equipment does not function properly.
Otherwise safety is not assured due to an unexpected malfunction or incorrect operation.
- Do not use solvents such as benzene, thinner etc. to clean each product.
They could damage the surface of the body and erase the markings on the body.
Use a soft cloth to remove stains.
For heavy stains, use a cloth soaked with diluted neutral detergent and fully squeezed, then wipe up the stains again with a dry cloth.

1. Product Summary

1.1. Features

SI Unit

The SI (Serial Interface) Unit represents a PROFINET IO-device for SMC pneumatic valves. It is designed for digital data control by connecting compatible EX245 modules and for use within rugged industrial environments, especially automotive plants. The SI Unit has the following properties:

- (1) IP65 protection
- (2) Two connectors for supply voltages and two connectors for PROFINET IO connection, EX245-SPN1: 2 x Push Pull connectors (24 Volt) and 2 x Push Pull connectors (SCRJ)
EX245-SPN2: 2 x Push Pull connectors (24 Volt) and 2 x Push Pull connectors (RJ45)
- (3) Up to 32 solenoid valves
- (4) Up to 128 digital inputs
- (5) Up to 64 digital outputs independent of solenoid valves
- (6) Up to 8 modules (limited by the total current consumption)
- (7) FSU (Fast Startup) supported
- (8) Conformance Class C (Only for IRT switch function)
- (9) MRP (Media Redundancy Protocol) function supported
- (10) Maintenance alarm supported for the Fiber-optic cables(EX245-SPN1)
- (11) Integrated diagnostic and protection function
- (12) Maximum loop through current between power connectors is 10A
- (13) Galvanically isolated all power supplies
- (14) Free module configuration

Corresponding solenoid valve manifolds

- SY3000/5000/7000
- SV1000/2000/3000
- VQC1000/2000/4000/5000

Compatible EX245 I/O modules

- Digital Input Module: EX245-DX1 (16 digital inputs)
- Digital Output Module: EX245-DY1 (8 digital outputs)

1.2. Structure

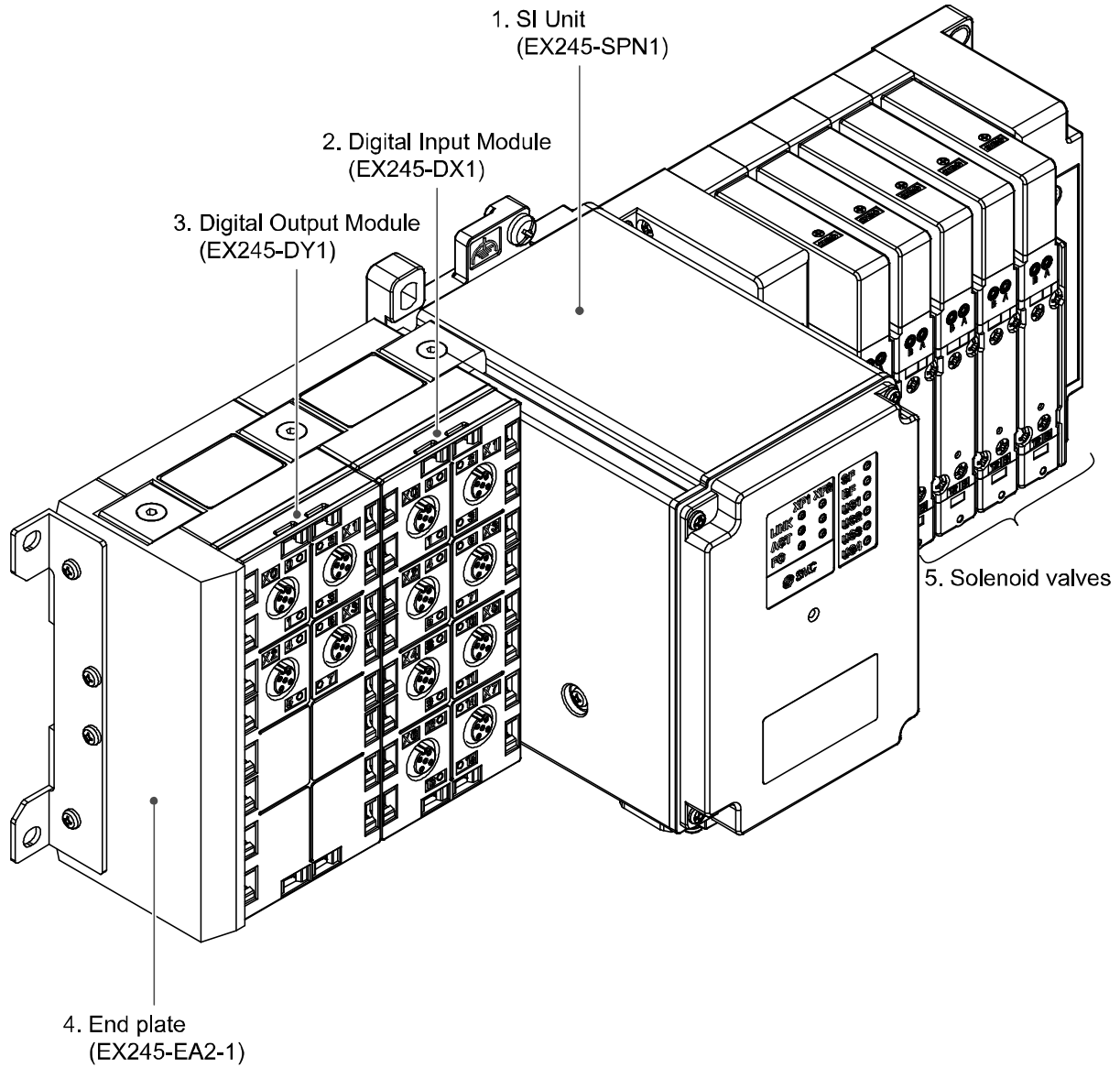

No.	Components	Function
1	SI Unit	Fieldbus, valve interface and supply voltage to modules
2	Digital Input Module	Supply voltage to sensors and input digital data
3	Digital Output Module	Output to electric loads
4	End plate	End plate of module
5	Solenoid valves	Operate pneumatic devices

Fig. 1-1 System structure

2. General Specifications

Table. 2-1 EX245 series general specifications

Item	Specification
Rated voltage	24 VDC
Allowable instantaneous electrical stop	1 ms maximum
Protection class	IP65 (when fully installed or fitted with protective cover) (complies with IEC 60529)
Standard	CE marked (EMC directive, RoHS directive)
Withstand voltage	500 VAC 1 min. (between FE and all accessible terminals)
Insulation resistance	10 MΩ or more (500 VDC is given between FE and all accessible terminals)
Ambient temperature	Operation: -10 °C to 50 °C Storage: -20 °C to 60 °C
Ambient humidity	35% to 85% RH (non-condensing)
Vibration resistance	10 Hz to 57 Hz (constant amplitude) 0.75 mm 57 Hz to 150 Hz (constant acceleration) 49 m/s ² 2 hours for each direction X, Y and Z
Impact resistance	147 m/s ² is given 3 times for each direction X, Y and Z
Operating environment	No corrosive gas

3. Installation

3.1. Mounting

⚠ Caution

To prevent manifold components being damaged, apply the recommended tightening torque. Mount the manifold using the 8 mounting positions on the base with screws. Required screws are as follows:

- ① 2 x M5 (End plate: torque = 1.5 N·m)
- ② 2 x M5 (SI Unit: torque = 1.5 N·m)
- ③ 4 x M* (Valve manifold: refer to valve manifold catalogue)

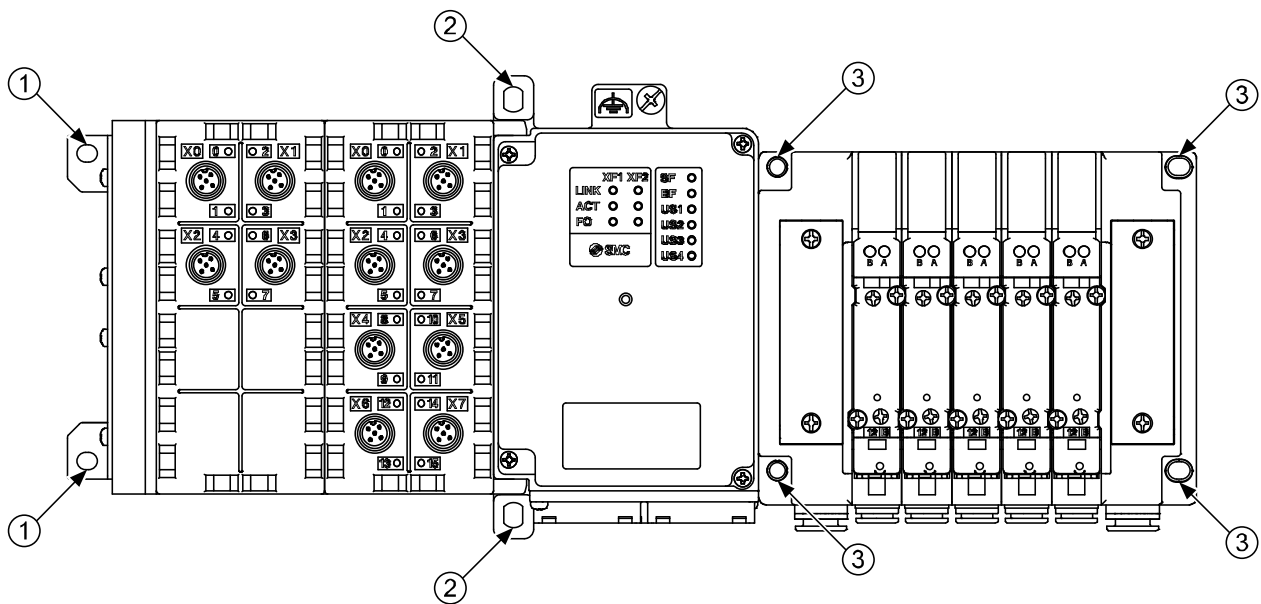

Fig. 3-1 Required screws

⚠ Caution

All manifolds are mounted using 8 screws (except VQC4000 which uses 7 screws).

3.1.1. Valve manifold connection

Connect the valve manifold with the 2 screws on the SI Unit. (hexagonal socket wrench size 2.5)

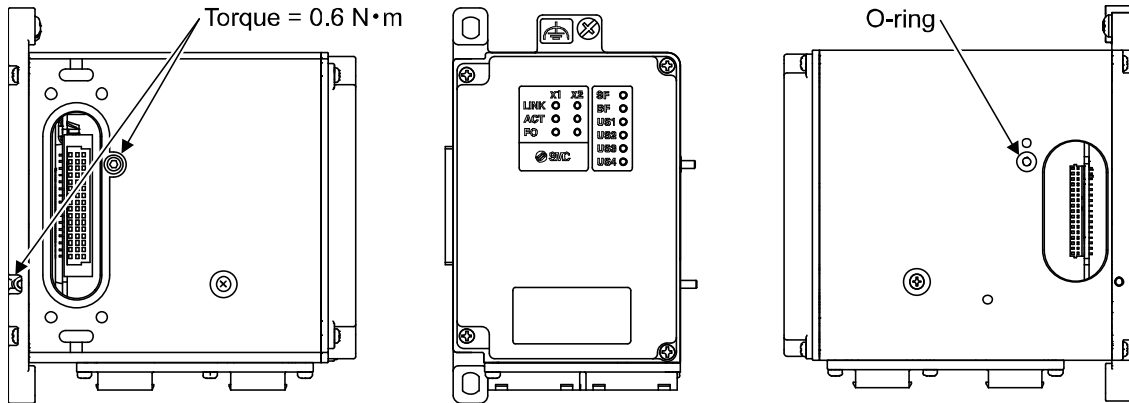

Fig. 3-2 Valve manifold connection

⚠ Caution

For a protection rating of IP65 to be ensured, apply the recommended tightening torque and make sure that the O-ring is positioned correctly on the screw.

3.1.2. Module connection

Connect the SI Unit, the Input/Output modules and the End plate with the 2 modular adaptor assemblies and a joint assembly. These are grouped together in the Joint pack, refer to the [Section 10.4](#).

- ① 1 x Joint assembly
- ② 2 x Modular adaptor assembly (hexagonal socket wrench size 2.5, torque = 1.3 N·m)

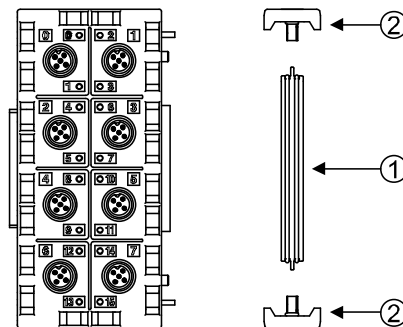

Fig. 3-3 Module connection

⚠ Caution

- For a protection rating of IP65 to be ensured modular adaptor assemblies and joint assembly must be installed between each module correctly.
- To prevent the modules and assemblies being damaged, apply the recommended tightening torque.

3.2. Wiring

⚠ Caution

To prevent damage, all voltages to the SI Unit must be turned off (i.e. de-energized) before the modules are installed or removed.

Wire the grounding cable, the PROFINET cables and the power cable.

EX245-SPN1

- ① M5, FE terminal screw (torque = 1.5 N·m)
- ② Push Pull connector (24 Volt), Power connection (XD1)
- ③ Push Pull connector (24 Volt), Power connection (XD2)
- ④ Push Pull connector (SCRJ), PROFINET connection Port1 (XF1)
- ⑤ Push Pull connector (SCRJ), PROFINET connection Port2 (XF2)

EX245-SPN2

- ① M5, FE terminal screw (torque = 1.5 N·m)
- ② Push Pull connector (24 Volt), Power connection (XD1)
- ③ Push Pull connector (24 Volt), Power connection (XD2)
- ④ Push Pull connector (RJ45), PROFINET connection Port1 (XF1)
- ⑤ Push Pull connector (RJ45), PROFINET connection Port2 (XF2)

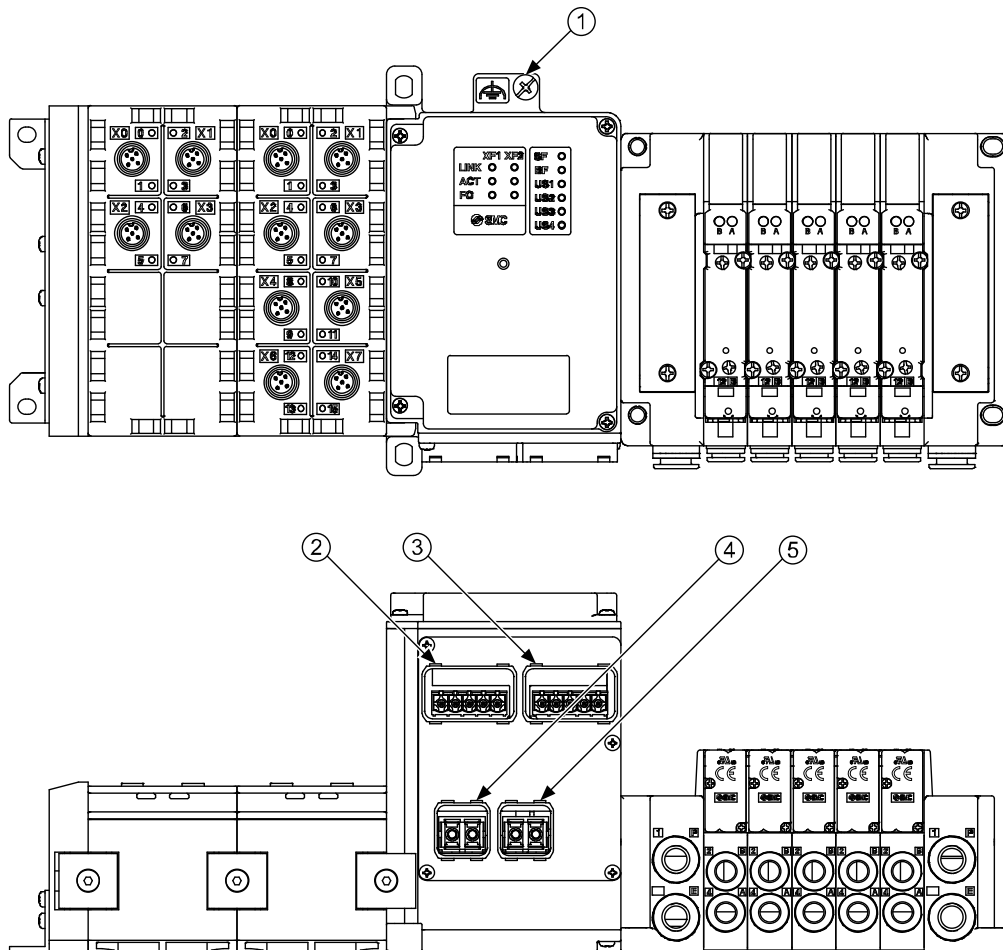

Fig. 3-4 Screw and connector allocation

3.2.1. Power/Bus connection

The EX245-SPN1 has two Power connectors (XD1/2) and two PROFINET communication connectors(XF1/2). If only one connector is used, cover the unused connector with a blanking cap so that the protection rating of IP65 is maintained.

⚠ Caution

- Blanking caps must be fitted to all unused bus & power connector ports to ensure an IP65 rating.
- "Blanking caps must be fitted to all unused bus & power connector ports to prevent foreign matter such as dust or debris from getting inside the product and eye exposure to the light beam from the SCRJ connectors."
- Power and bus lines must be installed correctly.
- To prevent manifold components of the EX245 from being damaged the supply lines for the electronics and for the load voltage must be protected externally with a fuse.
- Maximum loop through current(10A) between connectors must not be exceeded.
- The SI unit makes use of a CLASS 1 LASER product. Do not stare into beam visible at XF1/2.

Power connectors

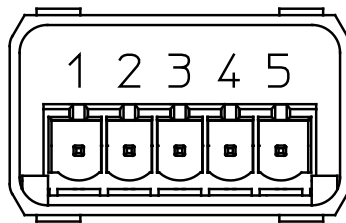

Pin	Remarks
1	24 V (US1)
2	0 V (US1)
3	24 V (US2)
4	0 V (US2)
5	FE

View of Push Pull connector (XD1/XD2)

Fig. 3-5 Pin allocation of Push Pull connector (24 V) for EX245-SPN1/SPN2

PROFINET communication connectors

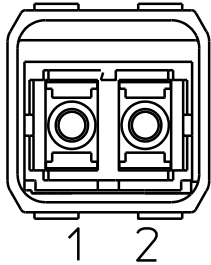

View of Push Pull connector (XF1/XF2)

Pin	Port1/Port2
1	TX Transmit Data
2	RX Receive Data

Fig. 3-6 Pin allocation of Push Pull connector (SCRJ) for EX245-SPN1

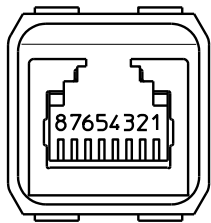

View of Push Pull connector (XF1/XF2)

Pin	Port1 (XF1) Port type: MDI	Port2 (XF2) Port type: MDI-X
1	TD+ Transmit data+	RD+ Receive data+
2	TD- Transmit data-	RD- Receive data-
3	RD+ Receive data+	TD+ Transmit data+
4	-	-
5	-	-
6	RD- Receive data-	TD- Transmit data-
7	-	-
8	-	-

Fig. 3-7 Pin allocation of Push Pull connector (RJ45) for EX245-SPN2

NOTE

- When you use the EX245-SPN2 and the Autonegotiation function is disabled, you must select the correct network cable, refer to Fig 3-8, 3-9.
- Auto crossover function is not available when the Autonegotiation function is disabled.
- Auto crossover function shall be capable of switching over their twisted pair ports automatically between MDI and MDI-X pin assignment.

The following figure Fig. 3-8 shows examples on the use of two different cable types.

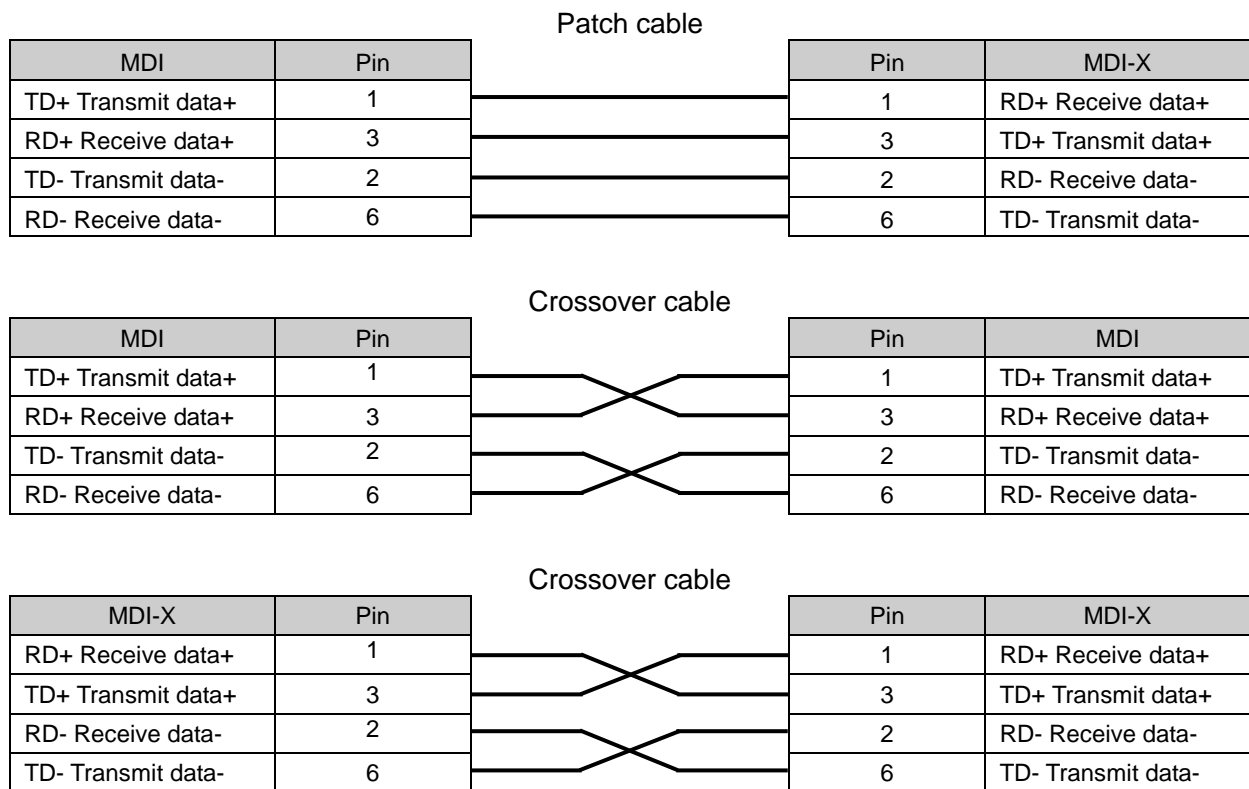
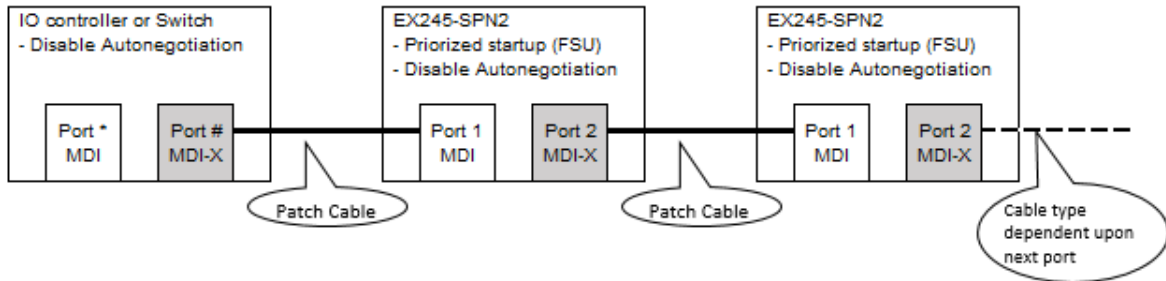

Fig. 3-8 Patch and Crossover Cable details

Connection example

Case 1



Case 2

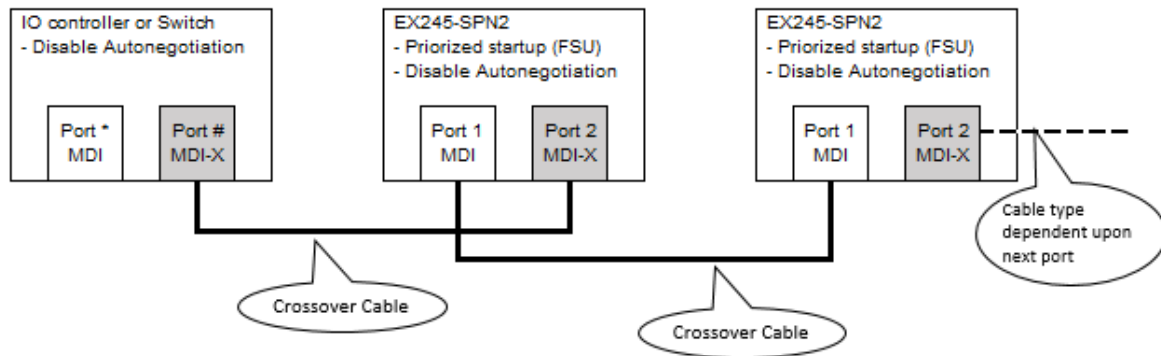

Fig. 3-9 Connection examples when using FSU.

3.2.2. FE terminal

The SI Unit must be connected to FE (Functional Earth) to divert electromagnetic interference. Connect to the grounding cable with FE terminal screw on the SI Unit. The other end of the grounding cable should be terminated to ground potential. For maximum protection the grounding cable should be as thick and short as reasonably possible.

3.2.3. Sensor/Load connection

Regarding the wiring of each module, refer to following section:

- EX245-DX1: [Section 7.3](#)
- EX245-DY1: [Section 8.3](#)

4. Commissioning

4.1. Configuration

The SI unit is a modular station that consists of several modules. Setup your PROFINET IO Controller's software to reflect the configuration of your system.

4.1.1. GSD file and symbol files

In order to configure the SI unit with your PROFINET IO Controller's software the appropriate GSD file is required. The GSD file contains all of necessary information to configure the SI unit on your PROFINET IO Controller's software.

In order to represent the SI unit in your PROFINET IO Controller's software the appropriate symbol files are required.

Current GSD file and symbol files name are as follows.

- GSD file: GSDML-V2.3-SMC-EX245-V1.0-*****.xml
- Symbol files: GSDML_0083_0056_EX2454N.bmp

4.1.2. Head Modules

The GSD file contains the description for two Head modules and three SI Units.

Table. 4-1 Head modules

Head module	Available SI Unit
EX245-PN FX	EX245-SPN1
EX245-PN Cu	EX245-SPN2

4.1.3. Modules

The SI unit can consists of the following modules.

Table. 4-2 Overview of modules for the SI unit

Module name	Occupied bytes	Allowable slot	Note
Diagnostics type 1	4 bytes (IN)	1	Refer to Section 5.1.1
Diagnostics type 2	4 bytes (IN)	1	Refer to Section 5.2.2
Valves (16 coils)	2 bytes (OUT)	1...2	Refer to Section 6.3
Valves (32 coils)	4 bytes (OUT)	1...2	
EX245-DX1-X36	2 bytes (IN)	2...10	Refer to Section 7.4
EX245-DY1-X37	1 byte (OUT)	2...10	Refer to Section 8.4
EX245-DY2-X37	1 byte (OUT)	2...10	Option
EX245-AX2-X38	3 bytes (IN) 1 byte (OUT)	2...10	Option

Caution

- When you operate the digital input module(EX245-DX1) and the digital output module(EX245-DY1), select the digital input module(EX245-DX1-X36) and the digital output module(EX245-DY1-X37) as the configuration module on the master software (Siemens "STEP7", etc.).
- The modules "EX245-DY2-X37" and "EX245-AX2-X38" are options which can be enabled to use a special module.

4.1.4. Configuration steps

Enter the modules in your configuration program corresponding to the actual module layout and a "Diagnostics type" module if required (Refer to [Section 6.1](#)). If the configuration does not match the actual layout, the connection to the IO Controller will not be established.

Configuration steps:

- When using the EX245-SPN1, choose the Head module "EX245-PN FX" on the configuration software. When using the EX245-SPN2, choose the Head module "EX245-PN Cu".
- Enter the "Diagnostics type 1/2" modules in Diagnostics slot if required.
- Enter one of the "Valves (16 coils)" or "Valves (32 coils)" modules in Slot 1.
- Enter all other modules that are connected on the left hand side of the SI Unit (max. 8 modules).

Example of a configuration

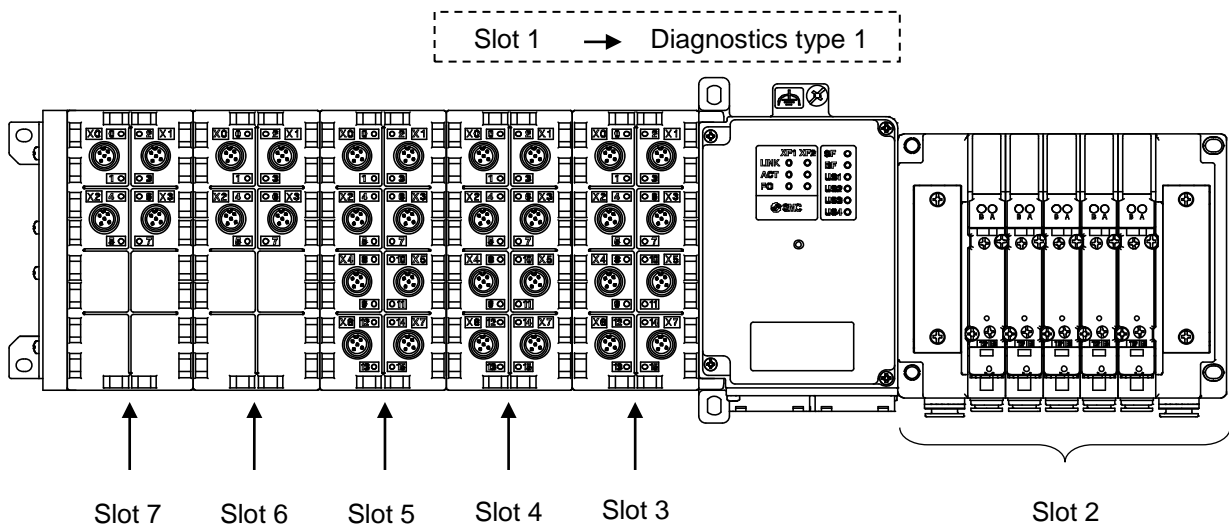

Slot number	Actual module	Configuration module	Input bytes	Output bytes
Slot 1	-	Diagnostics type 1	4	-
Slot 2	5 x Double solenoid Valves	Valves (16 coils)	-	2
Slot 3	EX245-DX1	EX245-DX1-X36	2	-
Slot 4	EX245-DX1	EX245-DX1-X36	2	-
Slot 5	EX245-DX1	EX245-DX1-X36	2	-
Slot 6	EX245-DY1	EX245-DY1-X37	-	1
Slot 7	EX245-DY1	EX245-DY1-X37	-	1

Fig. 4-1 Example of assignment of modules

NOTE

- Even if the valves are not connected to the SI Unit, you have to enter one of the "Valves" modules in Slot 1 or Slot 2.
- When you change the module configuration in your configuration program, you need to turn off the supply for the logic/sensors "US1" and turn it on again.

4.2. Parameterisation

4.2.1. System parameters

The SI unit has the following system parameters.

Table. 4-1 System parameters

Parameters	Range of values	Default	Meaning
US1 Diagnosis	Enable Disable	Enable	When this parameter is enabled, the system generates a diagnostics event if it detects that US1 has dropped or off.
US2 Diagnosis	Enable Disable	Disable	When this parameter is enabled, the system generates a diagnostics event if it detects that US2 has dropped or off.
US3 Diagnosis	Enable Disable	Disable	When this parameter is enabled, the system generates a diagnostics event if it detects that first additional loads supply (US3) has dropped or off.
US4 ... US10 Diagnosis	Enable Disable	Disable	When this parameter is enabled, the system generates a diagnostics event if it detects that one of additional loads supplies excluding the first one (US4, US5, etc.) has dropped or off.

NOTE

- The parameters "US3 Diagnosis" and "US4 ... US10 Diagnosis" are options which can be enabled to use a special module.

4.2.2. Module parameters

4.2.2.1. Module parameters for valves

The "Valves (16 coils)" has the following module parameters:

Table. 4-2 Module parameters of Valves (16 coils)

Name	Range of values	Default	Meaning
Valve Output 0	Force to OFF Force to ON Hold last state	Force to OFF	When a bus fault occurs, the output can be made to react in one of the following ways: •Force to OFF •Force to ON •Hold last state
Valve Output 1	Force to OFF Force to ON Hold last state	Force to OFF	
...	
Valve Output 15	Force to OFF Force to ON Hold last state	Force to OFF	

The "Valves (32 coils)" has the following module parameters.

Table. 4-3 Module parameters of Valves (32 coils)

Name	Range of values	Default	Meaning
Valve Output 0	Force to OFF Force to ON Hold last state	Force to OFF	When a bus fault occurs, the output can be made to react in one of the following ways: •Force to OFF •Force to ON •Hold last state
Valve Output 1	Force to OFF Force to ON Hold last state	Force to OFF	
...	
Valve Output 31	Force to OFF Force to ON Hold last state	Force to OFF	

4.2.2.2. Module parameters for EX245-DX1-X36

The EX245-DX1-X36 has no module parameters that you can set.

4.2.2.3. Module parameters for EX245-DY1-X37

The EX245-DY1-X37 have the following module parameters.

Table. 4-4 Module parameters of EX245-DY1-X37

Name	Range of values	Default	Meaning
Digital Output 0	Force to OFF Force to ON Hold last state	Force to OFF	When a bus fault occurs, the output can be made to react in one of the following ways: •Force to OFF •Force to ON •Hold last state
Digital Output 1	Force to OFF Force to ON Hold last state	Force to OFF	
...	
Digital Output 7	Force to OFF Force to ON Hold last state	Force to OFF	

5. Diagnosis

5.1. Diagnostics data on I/O mapping

The SI unit can be allocated diagnostics data as digital input data on I/O mapping, if one of the module, Diagnostics type 1 or Diagnostics type 2, is configured. Use PROFINET master's software to select a requested diagnostics type to allocate the diagnostics data on I/O mapping.

5.1.1. Diagnostics type 1

Table. 5-1 Overview of Diagnostics type 1

Byte	Description
0	General diagnostics 1
1	General diagnostics 2
2	Valve diagnostics 1
3	Valve diagnostics 2

5.1.1.1. General diagnostics 1

Table. 5-2 General diagnostics 1

Bit	Description	Explanation
0	System fault	0: No error on Diagnostics data on I/O mapping 1: At least one error on Diagnostics data on I/O mapping has occurred
1	Valve-coil(s) short circuit	0: No valve coil(s) have a short circuit 1: At least one valve coil has a short circuit
2	Module error	0: No module has an error 1: At least one connected module has an error
3	Changed module layout	0: Module layout has not changed 1: Module layout has changed or is different from Configuration setting
4	US1 Diagnostics	0: US1 present (> approx. 21.6 VDC) 1: US1 has dropped (< approx. 20.4 VDC)
5	US2 Diagnostics	0: US2 present (> approx. 22.8 VDC) 1: US2 has dropped (< approx. 21.6 VDC) or not present
6	US3 Diagnostics	0: First additional supply for the loads (US3) present (> approx. 22.8 VDC) 1: First additional supply for the loads (US3) has dropped (< approx. 21.6 VDC) or not present
7	US4 Diagnostics	0: All additional supplies for the loads excluding the first one (US4, US5, etc.) present (> approx. 22.8 VDC) 1: At least one of additional supplies for the loads excluding the first one (US4, US5, etc.) has dropped (< approx. 21.6 VDC) or not present

NOTE

- The diagnostics on I/O mapping "US3 Diagnostics" and "US4 Diagnostics" are options which can be enabled to use a special module.

5.1.1.2. General diagnostics 2

Table. 5-3 General diagnostics 2

Bit	Description	Explanation
0	Module 1 error	0: No error or not connected, 1: Module 1 has an error
1	Module 2 error	0: No error or not connected, 1: Module 2 has an error
2	Module 3 error	0: No error or not connected, 1: Module 3 has an error
3	Module 4 error	0: No error or not connected, 1: Module 4 has an error
4	Module 5 error	0: No error or not connected, 1: Module 5 has an error
5	Module 6 error	0: No error or not connected, 1: Module 6 has an error
6	Module 7 error	0: No error or not connected, 1: Module 7 has an error
7	Module 8 error	0: No error or not connected, 1: Module 8 has an error

5.1.1.3. Valve diagnostics 1

Table. 5-4 Valve diagnostics 1

Bit	Description	Explanation
0	Valve 0, 1 diagnostics	0: No error, 1: Short circuit
1	Valve 2, 3 diagnostics	0: No error, 1: Short circuit
2	Valve 4, 5 diagnostics	0: No error, 1: Short circuit
3	Valve 6, 7 diagnostics	0: No error, 1: Short circuit
4	Valve 8, 9 diagnostics	0: No error, 1: Short circuit
5	Valve 10, 11 diagnostics	0: No error, 1: Short circuit
6	Valve 12, 13 diagnostics	0: No error, 1: Short circuit
7	Valve 14, 15 diagnostics	0: No error, 1: Short circuit

5.1.1.4. Valve diagnostics 2

Table. 5-5 Valve diagnostics 2

Bit	Description	Explanation
0	Valve 16, 17 diagnostics	0: No error, 1: Short circuit
1	Valve 18, 19 diagnostics	0: No error, 1: Short circuit
2	Valve 20, 21 diagnostics	0: No error, 1: Short circuit
3	Valve 22, 23 diagnostics	0: No error, 1: Short circuit
4	Valve 24, 25 diagnostics	0: No error, 1: Short circuit
5	Valve 26, 27 diagnostics	0: No error, 1: Short circuit
6	Valve 28, 29 diagnostics	0: No error, 1: Short circuit
7	Valve 30, 31 diagnostics	0: No error, 1: Short circuit

5.1.2. Diagnostics type 2

Table. 5-6 Overview of Diagnostics type 2

Byte	Description
0	General diagnostics 1
1	Valve diagnostics 1
2	General diagnostics 2
3	Valve diagnostics 2

5.1.2.1. General diagnostics 1

Table. 5-7 General Diagnostics 1

Bit	Description	Explanation
0	Maximum number of valves	0: 16 coils 1: 32 coils
1	Valve coil(s) short circuit	0: No valve coils have short circuit 1: At least one valve coil has a short circuit
2	US1 diagnostics 1	0: US1 present (> approx. 21.6 VDC) 1: US1 has dropped (< approx. 20.4 VDC)
3	Reserved	Fixed 0
4	US2 diagnostics 1	0: US2 present (> approx. 22.8 VDC) 1: US2 has dropped (< approx. 21.6 VDC)
5	US2 diagnostics 2	0: US2 present (> approx. 17 VDC) 1: US2 has dropped (< approx. 17 VDC) or not present
6	Reserved	Fixed 0
7	US1 diagnostics 2	0: US1 present (> approx. 17 VDC) 1: US1 has dropped (< approx. 17 VDC) or not present

5.1.2.2. Valve diagnostics 1

Table. 5-8 Valve diagnostics 1

Bit	Description	Explanation
0	Valve 0, 1 diagnostics	0: Short circuit, 1: No error
1	Valve 2, 3 diagnostics	0: Short circuit, 1: No error
2	Valve 4, 5 diagnostics	0: Short circuit, 1: No error
3	Valve 6, 7 diagnostics	0: Short circuit, 1: No error
4	Valve 8, 9 diagnostics	0: Short circuit, 1: No error
5	Valve 10, 11 diagnostics	0: Short circuit, 1: No error
6	Valve 12, 13 diagnostics	0: Short circuit, 1: No error
7	Valve 14, 15 diagnostics	0: Short circuit, 1: No error

5.1.2.3. General diagnostics 2

Table. 5-9 General diagnostics 2

Bit	Description	Explanation
0	Module 1 diagnostics	0: No error or not connected, 1: Short circuit
1	Module 2 diagnostics	0: No error or not connected, 1: Short circuit
2	Module 3 diagnostics	0: No error or not connected, 1: Short circuit
3	Module 4 diagnostics	0: No error or not connected, 1: Short circuit
4	Module 5 diagnostics	0: No error or not connected, 1: Short circuit
5	Module 6 diagnostics	0: No error or not connected, 1: Short circuit
6	Module 7 diagnostics	0: No error or not connected, 1: Short circuit
7	Module 8 diagnostics	0: No error or not connected, 1: Short circuit

5.1.2.4. Valve diagnostics 2

If the maximum number of valves is 16 coils in the EX245-SPN1/SPN2, the diagnostics will be set FFh.

Table. 5-10 Valve diagnostics 2

Bit	Description	Explanation
0	Valve 16, 17 diagnostics	0: Short circuit, 1: No error
1	Valve 18, 19 diagnostics	0: Short circuit, 1: No error
2	Valve 20, 21 diagnostics	0: Short circuit, 1: No error
3	Valve 22, 23 diagnostics	0: Short circuit, 1: No error
4	Valve 24, 25 diagnostics	0: Short circuit, 1: No error
5	Valve 26, 27 diagnostics	0: Short circuit, 1: No error
6	Valve 28, 29 diagnostics	0: Short circuit, 1: No error
7	Valve 30, 31 diagnostics	0: Short circuit, 1: No error

5.2. Maintenance alarm for the Fiber-optic cables

When the strength of the fiber-optic communication is not enough, the SI Unit detects "Maintenance alarm" for the fiber-optic cable. Then SF LED of the SI Unit is ON and FO LED of the SI Unit is ON (the strength is more than 0 dB) or flashing (more than 0 dB but less than 2 dB), refer to the [Section 7.4.3.](#) At the time if the Port communication setting is configured to "Automatic (monitor)" settings, the diagnostics (alarm) is detected.

In order to recover from this alarm, please check the fiber-optic cable at first.

Example

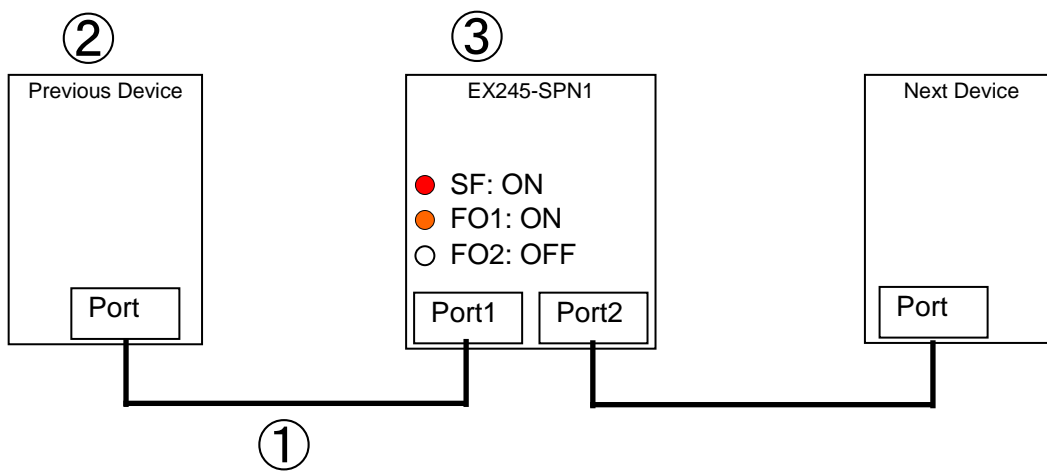

Step 1: Check/exchange ① the cable.

Step 2: Check/exchange ② the previous device.

Step 3: Check/exchange ③ the SI Unit.

6. SI Unit

6.1. Parts and description

EX245-SPN1
EX245-SPN2

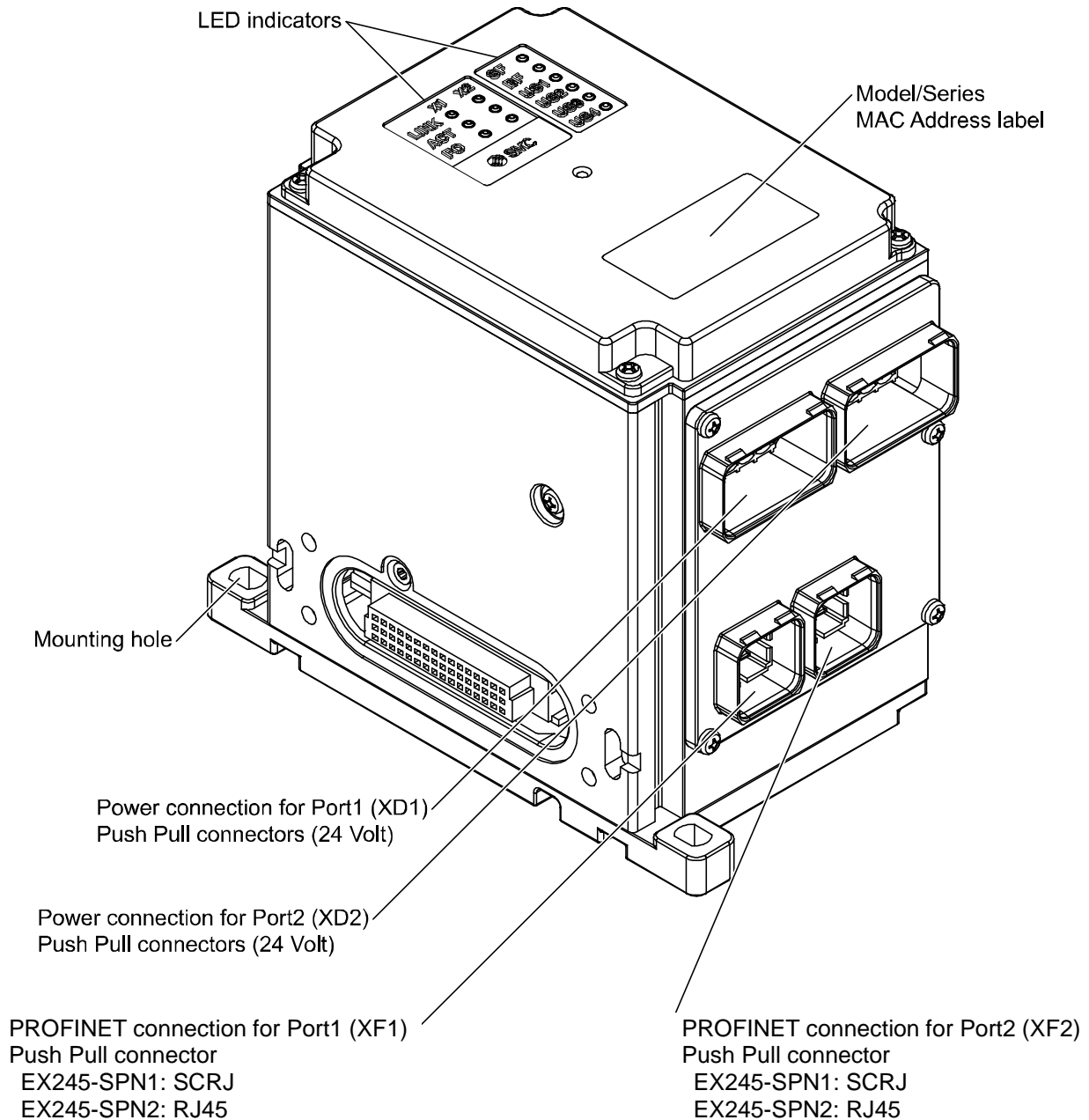

Fig. 6-1 Allocation of parts on the EX245-SPN1/SPN2

6.2. Specifications

Table. 6-1 Specifications

Item	Description	
	EX245-SPN1	EX245-SPN2
General		
Dimensions (W x L x H) in mm	85 x 148.5 x 130	
Weight	1000 g or less	
Housing materials	Aluminium, PBT	
Max. number of modules	8	
Max. number of digital inputs	128	
Max. number of digital outputs	64 (independent of solenoid valves)	
Electrical		
Internal current consumption at 24 VDC (Via US1)	300 mA or less	250 mA or less
Protection against polarity reversal	Yes (US1 and US2)	
Loop through current between power connector	10 A or less	
US1	Operating voltage	24 VDC +20%/-15%
	Under-voltage detection	Detected: < approx. 20.4 VDC Cancelled : > approx. 21.6 VDC
	Max. current	6 A
	Dropout voltage (sensors)	< approx. 17 VDC
US2	Operating voltage	24 VDC +20%/-15%
	Under-voltage detection	Detected: < approx. 21.6 VDC Cancelled : > approx. 22.8 VDC
	Max. current	4 A
	Dropout voltage (valves/loads)	< approx. 17 VDC
	Voltage drop to valve supply	Max. 1.2 V at 24 VDC
Galvanic isolation	Yes (between US1 and US2)	
Solenoid valve		
Applicable series	SY series	SY3000/5000/7000
	SV series	SV1000/2000/3000
	VQC series	VQC1000/2000/4000/5000
Max. number of solenoid valves	32 solenoid coils	
Output type of solenoid	Source/PNP (negative common)	
Over current protection	Yes	
Over current detection	Yes	
Fieldbus		
Bus protocol	PROFINET I/O	
Conformance Class C	Yes (Only for IRT switch function)	
Fast Start Up	Yes	
MRP (Media Redundancy Protocol)	Yes	
Maintenance alarm for the Fiber – optic cable	Yes	
Vendor ID	0083h	
Device ID	0056h	
GSD file	GSDML-V2.3-SMC-EX245-V1.0-*****.xml	

6.4. LED indicators

The LED indicators are arranged on the SI Unit as shown in the illustration below.

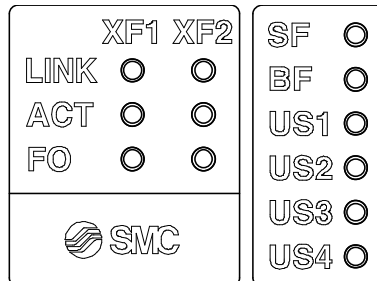

Designation	Description	Colour
LINK (XF1)	Connection via PROFINET on Port1 (XF1)	Green
ACT (XF1)	Data exchange on Port1 (XF1)	Yellow
LINK (XF2)	Connection via PROFINET on Port2 (XF2)	Green
ACT (XF2)	Data exchange on Port2 (XF2)	Yellow
FO1 (XF1)	Fiber-Optic communication diagnostics for Port 1 (XF1)	Orange
FO2 (XF2)	Fiber-Optic communication diagnostics for Port 2 (XF2)	Orange
SF	System fault	Red
BF	Bus fault	Red
US1	Supply for the logic/sensors	Green
US2	Supply for the valves/loads	Green
US3	Option	-
US4	Option	-

Fig. 6-3 LED indicators of the SI unit

NOTE

- FO1, FO2 LED is for EX245-SPN1. EX245-SPN2 is not used.

6.4.1. LINK indicator

Table. 6-1 LINK indicator

LINK	Meaning
ON	Connection via Ethernet to the SI Unit via Port 1/2 (XF1/2)
OFF	No connection established via Port 1/2 (XF1/2)

6.4.2. ACT indicator

Table. 6-2 ACT indicator

ACT	Meaning
ON	Transmission or reception of Ethernet telegrams on Port 1/2 (XF1/2)
OFF	No transmission or reception of Ethernet telegrams on Port 1/2 (XF1/2)

6.4.3. FO indicator

Table. 6-3 FO indicator

FO 1/2	Meaning
OFF	The strength of the fiber-optic communication is more than 2 dB on Port 1/2 (XF1/2).
Flash	The strength of the fiber-optic communication is more than 0 dB but less than 2 dB on Port 1/2 (XF1/2).
ON	The strength of the fiber-optic communication is 0 dB on Port 1/2 (XF1/2).

6.4.4. SF and BF indicators

Table. 6-4 SF and BF indicators

SF	BF	Meaning
OFF	OFF	No fault (The SI Unit is currently exchanging data with the IO Controller without errors.)
---	Flash	Faulty or no connect message frame (although the SI Unit is physically connected to the bus). <ul style="list-style-type: none"> • Configuration is defective, or before initial commissioning has been done. • Device name is different from configuration setting. • The GSD file is not correct. • The communication between IO Controller to SI Unit is defective.
OFF	ON	The SI Unit is not connecting to any bus.
Flash at 2 Hz	OFF	The connection to the IO Controller is OK but the following diagnostic event occurred. <ul style="list-style-type: none"> • At least one valve coil has a short circuit.
Flash at 0.5 Hz	---	The following diagnostic event occurred. <ul style="list-style-type: none"> • At least one connected module has a short circuit or the module layout has changed.
ON	---	The following diagnostic event occurred. <ul style="list-style-type: none"> • The configuration data sent by the IO Controller does not match the actual layout. • Power supply is not present or is below the dropout level. • At least one valve coil has a short circuit and at least one connected module has a short circuit or the module layout has changed. The SI Unit has an internal error. <ul style="list-style-type: none"> • An incompatible module is connected to the SI Unit. Strength of the Fiber-Optic. <ul style="list-style-type: none"> • Communication is less than 2 dB

6.4.5. US1 indicator

Table. 6-5 US1 indicator

US1	Meaning
OFF	US1 is not present or is below the dropout level (< approx. 17 V DC).
Flash	US1 is below the permissible level but above the dropout level (17 to 20.4 V DC).
ON	US1 is present (> approx. 21.6 V DC).

6.4.6. US2 indicator

Table. 6-6 US2 indicator

US2	Meaning
OFF	US2 is not present or is below the dropout level (< approx. 17 V DC).
Flash	US2 is below the permissible level but above the dropout level (17 to 21.6 V DC).
ON	US2 is present (> approx. 22.8 V DC).

6.5. Block diagram

Following figure shows the block diagram of the EX245-SPN1

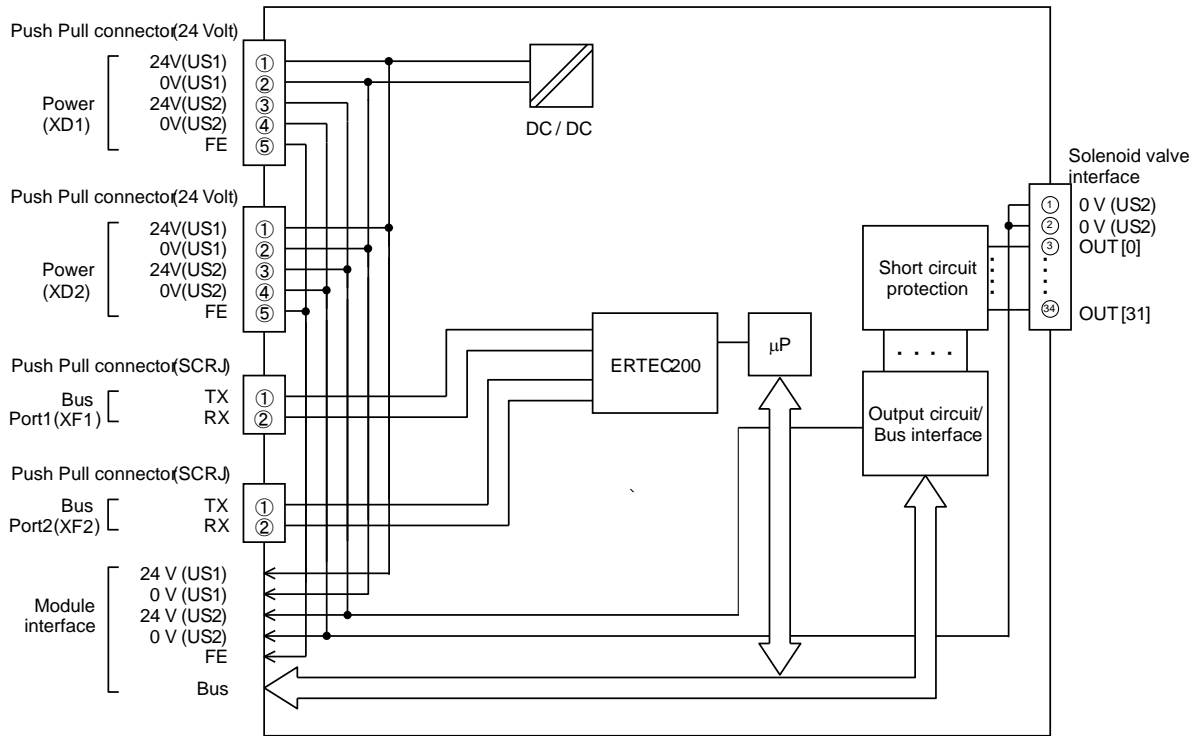

Fig. 6-4 Block diagram of the EX245-SPN1

Following figure shows the block diagram of the EX245-SPN2

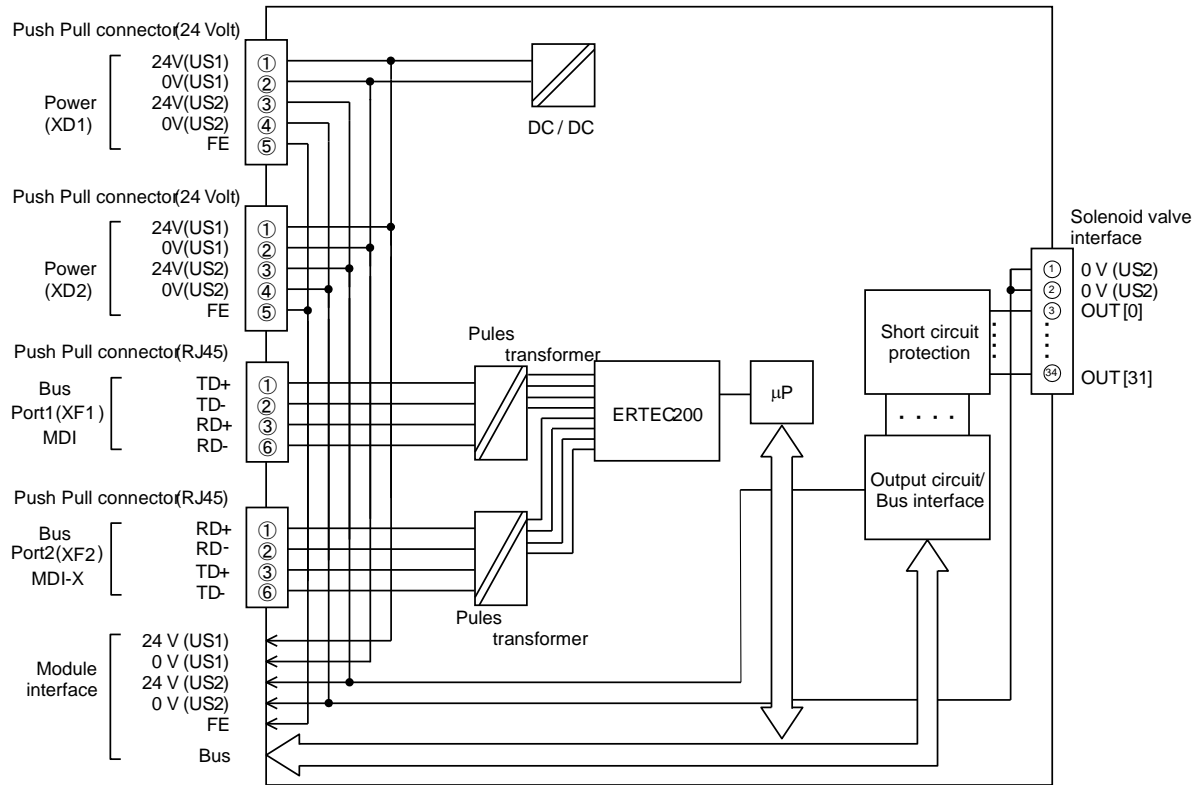

Fig. 6-5 Block diagram of the EX245-SPN2

7. Digital Input Module - EX245-DX1

7.1. Parts and description

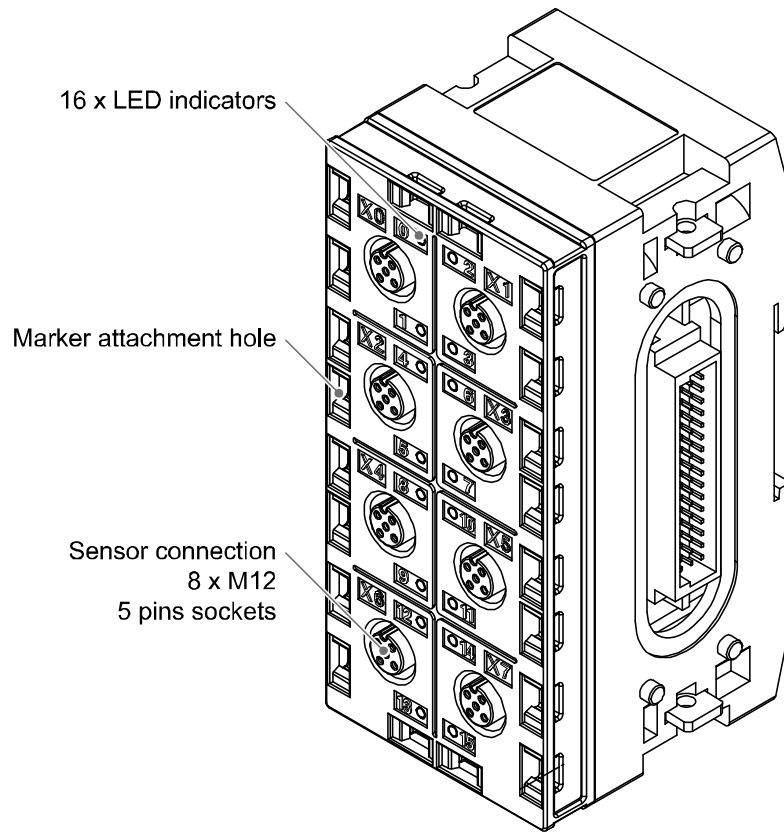

Fig. 7-1 Allocation of parts on the EX245-DX1

7.2. Specifications

Table. 7-1 EX245-DX1 specifications

Item	Description
General	
Dimensions (W x L x H) in mm	54 x 120 x 61
Weight	280 g or less
Housing material	Nylon, PBT
Electrical	
Rated supply voltage	24 VDC
Voltage drop to sensor supply	Max. 1.6 V
Internal current consumption at 24V DC	50 mA or less
Input connection type	8 x M12, 5-way sockets with double allocation A-coded (Normal key)
Over voltage protection	Yes, more than 30 VDC at US1 (sensor/input)
Short circuit protection	Yes
Sensor supply current per connector	Max. 0.5 A
Sensor supply current per module	Max. 2 A
Status indication	Yes, per input
Short circuit indication	Yes, per connector
Digital input	
Number of inputs	16
Input type	PNP
Signal 1	11 to 30 V
Signal 0	-3 to 5 V
Permissible residual current	Max. 1.5 mA
Input current signal 1	Typ. 4.5 mA

7.3. Wiring

Pin allocation of the M12, 5-way socket connector as shown in the following table:

Table. 7-2 Pin allocation of the connector for EX245-DX1

Pin	Allocation	View of connector (module side)
1	24 V	
2	DI (input signal "n+1")	
3	0 V (US1)	
4	DI (input signal "n")	
5	FE/Shield	

⚠ Caution

- To prevent damage, all power for the SI Unit and modules must be turned off (i.e. de-energized) before the modules are installed or removed.
- For a protection rating of IP65 to be ensured, all covering caps must be screwed down correctly after wiring and setting have been performed.
- For a protection rating of IP65 to be ensured, sockets that are not used must be closed with M12 Seal cap.

7.4. Process data

The EX245-DX1 (EX245-DX1-X36 module on a configuration software) occupies 2 bytes of input data. The following table shows the allocation of the digital inputs and the process image.

Table. 7-3 Digital input allocation and the process data

Connector position									
Connector designation	X0	X1	X2	X3	X4	X5	X6	X7	
Input	Pin 2	Bit 1	Bit 3	Bit 5	Bit 7	Bit 9	Bit 11	Bit 13	Bit 15
	Pin 4	Bit 0	Bit 2	Bit 4	Bit 6	Bit 8	Bit 10	Bit 12	Bit 14

7.5. LED indicators

The status indicators are arranged on the EX245-DX1 as shown in the illustration below.

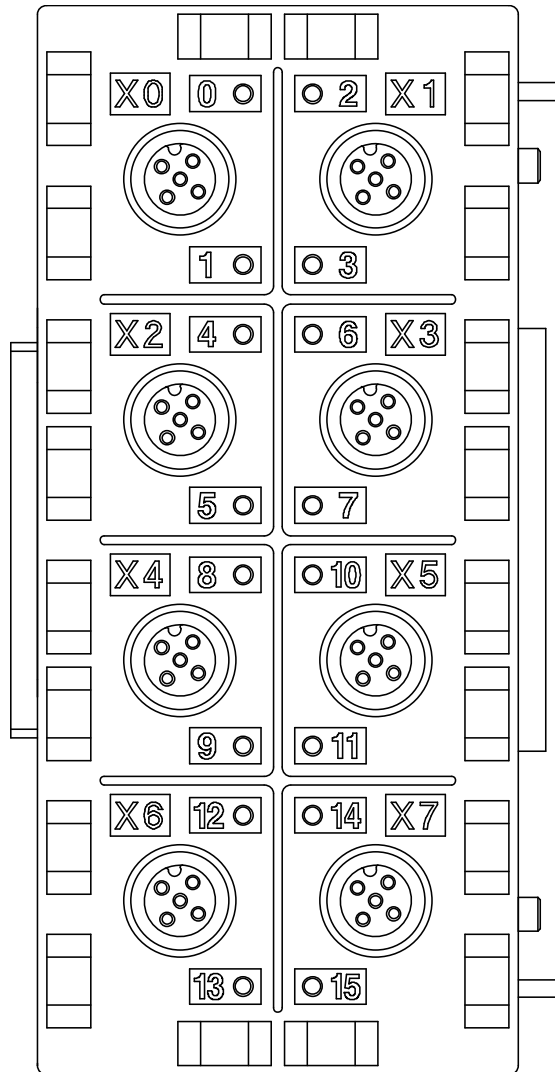

0 to15	Description
OFF	Input is not activated and no errors.
Green ON	Input is activated.
Red ON	Short circuit is detected.

Fig. 7-2 Status indicators of the EX245-DX1

7.6. Block diagram

The following figure shows the block diagram of the EX245-DX1.

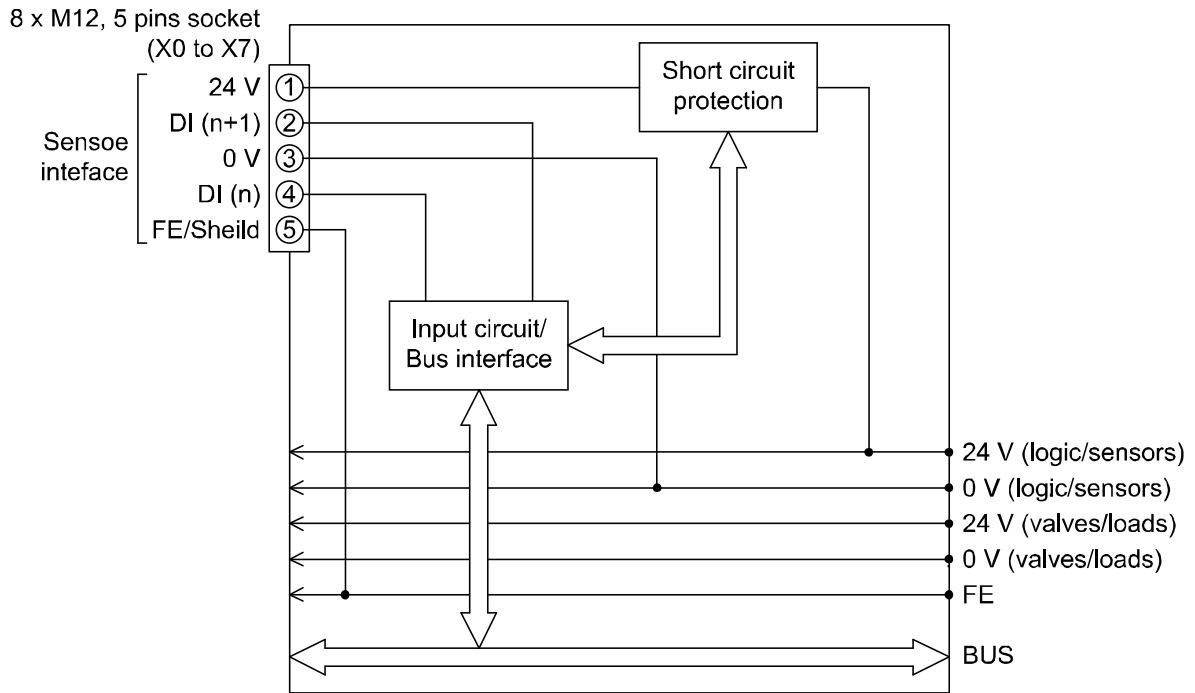

Fig. 7-3 Block diagram of the EX245-DX1

8. Digital Output Module - EX245-DY1

8.1. Parts and description

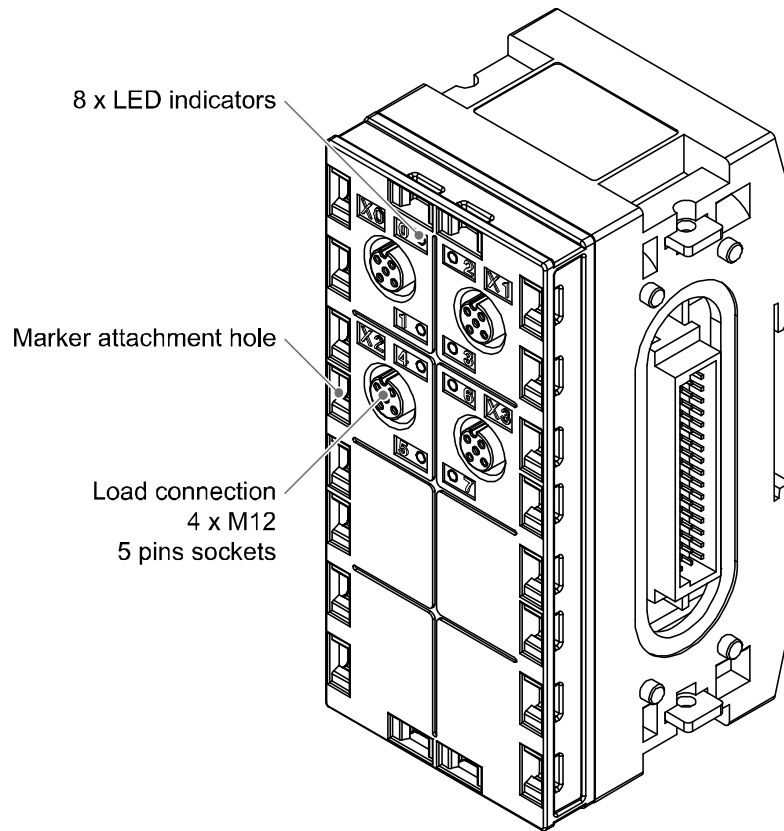

Fig. 8-1 Allocation of parts on the EX245-DY1

8.2. Specifications

Table. 8-1 EX245-DY1 specifications

Item	Description
General	
Dimensions (W x L x H) in mm	54 x 120 x 61
Weight	280 g or less
Housing material	Nylon, PBT
Electrical	
Rated supply voltage	24 VDC
Voltage drop to load supply	Max. 1.6 V
Internal current consumption at 24 VDC	50 mA or less
Load connection	4 x M12, 5-way sockets with double allocation A-coded (Normal key)
Over voltage protection	Yes, more than 30 VDC at US2 (solenoid/output)
Short circuit protection	Yes
Output current per output	Max.0.5 A
Output current per module	Max.2 A
Status indication	Yes, per output
Short circuit indication	Yes, per output
Digital output	
Number of outputs	8
Output type	PNP

8.3. Wiring

Pin allocation of the M12, 5-way socket connector as shown in the following table:

Table. 8-2 Pin allocation of the connector for EX245-DY1

Pin	Allocation	View of connector (module side)
1	N.C.	
2	DO (output signal "n+1")	
3	0 V (valves/loads)	
4	DO (output signal "n")	
5	FE/Shield	

⚠ Caution

- To prevent damage, all power for the SI Unit and modules must be turned off (i.e. de-energized) before the modules are installed or removed.
- For a protection rating of IP65 to be ensured, all covering caps must be screwed down correctly after wiring and setting have been performed.
- For a protection rating of IP65 to be ensured, sockets that are not used must be closed with M12 Seal cap.

8.4. Process data

The EX245-DY1 (EX245-DY1-X37 module on a configuration software) occupies 1 byte of output data. The following table shows the allocation of the digital outputs and the process image.

Table. 8-3 Digital output allocation and the process data

Connector position					
Connector designation		X0	X1	X2	X3
Output	Pin 2	Bit 1	Bit 3	Bit 5	Bit 7
	Pin 4	Bit 0	Bit 2	Bit 4	Bit 6

8.5. LED indicators

The status indicators are arranged on the EX245-DY1 as shown in the illustration below.

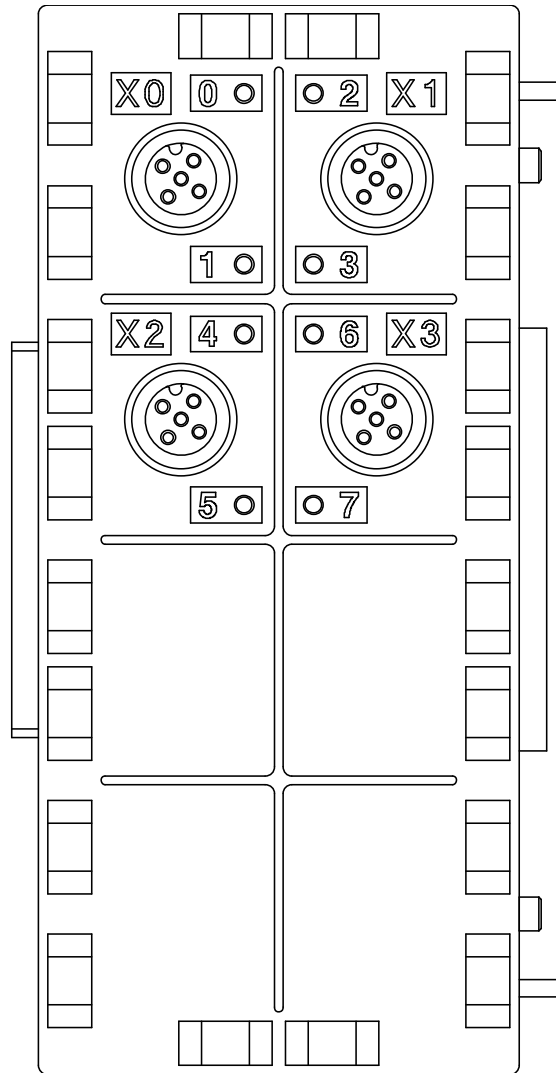

0 to 7	Description
OFF	Output is not activated and no errors.
Green ON	Output is activated.
Red ON	Short circuit is detected.

Fig. 8-2 Status indicators of the EX245-DY1

8.6. Block diagram

The following figure shows the block diagram of the EX245-DY1.

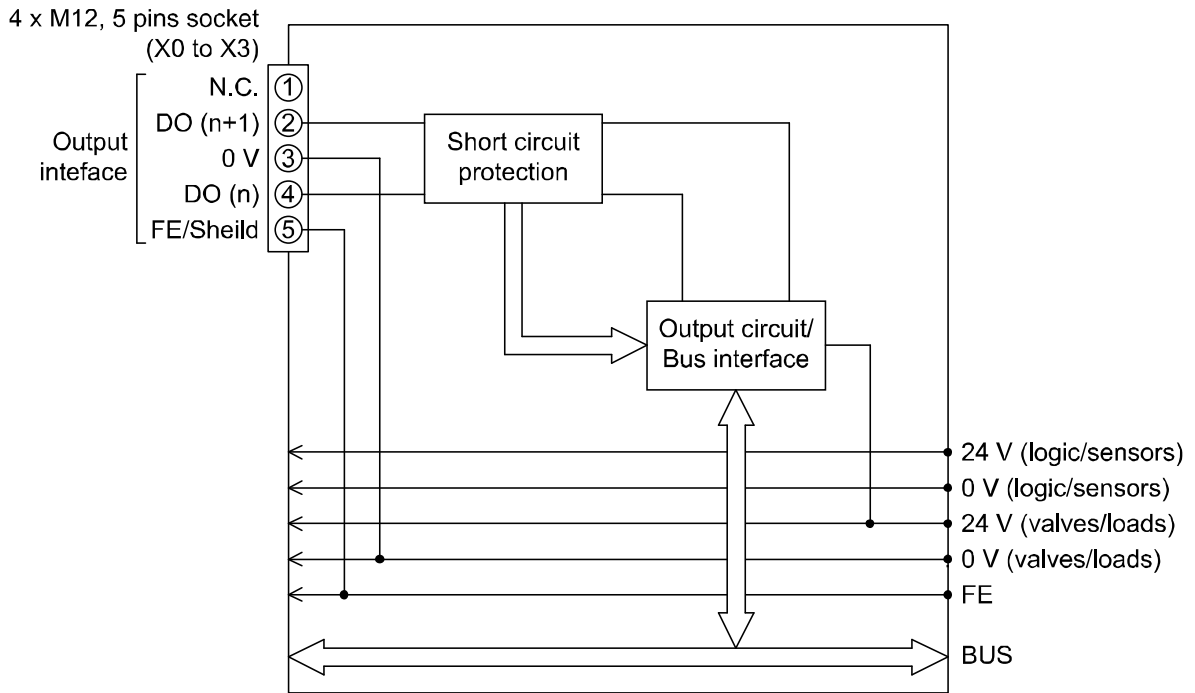

Fig. 8-3 Block diagram of the EX245-DY1

9. End Plate - EX245-EA2-1/2

9.1. Parts and description

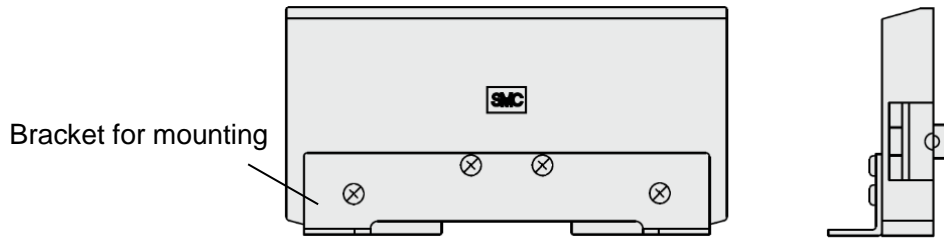

Fig. 9-1 Allocation of parts on the EX245-EA2-1

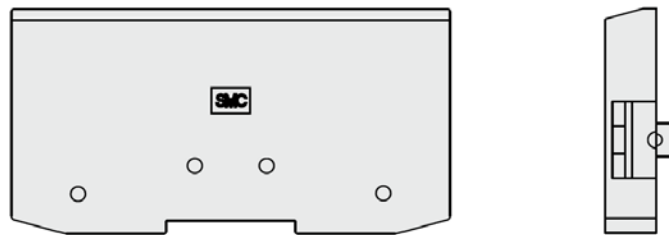

Fig. 9-2 Allocation of parts on the EX245-EA2-2

9.2. Specifications

Table. 9-1 EX245-EA2-1 specifications

Item	Description
General	
Dimensions (W x L x H) in mm	28.6 x 120 x 61.5
Weight	200 g or less
Housing material	Nylon

Table. 9-2 EX245-EA2-2 specifications

Item	Description
General	
Dimensions (W x L x H) in mm	14 x 120 x 61.5
Weight	100 g or less
Housing material	Nylon

NOTE

- EX245-EA2-2 can be used to have a special bracket which must be assembled with 4 P-tight Cross-recessed head tapping screws (3x6, torque: $0.8 \pm 0.05 \text{ N}\cdot\text{m}$)

10. Accessories

10.1. Markers

Markers are available in single sheets each containing 88 pieces,
For the EX245-DX1 and EX245-DY1 use the part No.EX600-ZT1.

Model No.: EX600-ZT1

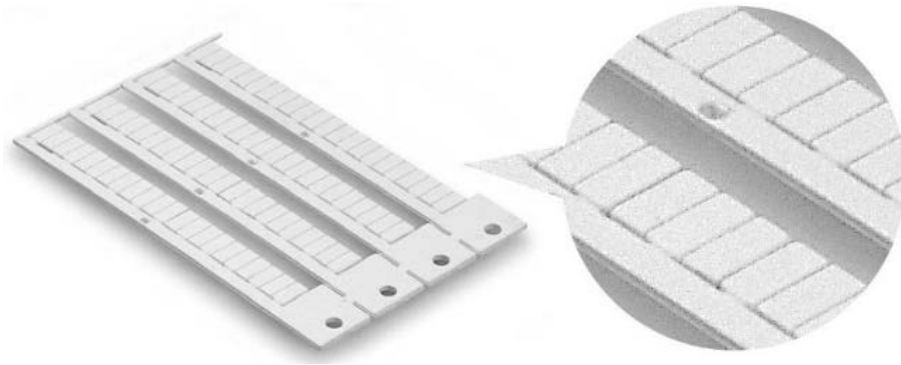

Fig. 10-1 EX600-ZT1

10.2. Y Connector

Y connectors can be used with the EX245-DX1 and EX245-DY1.

There are two options –

2 x M12 to M12

2 x M8 to M12

Model No.: PCA-1557785

(Y branch Connector (2 x M12 to M12))

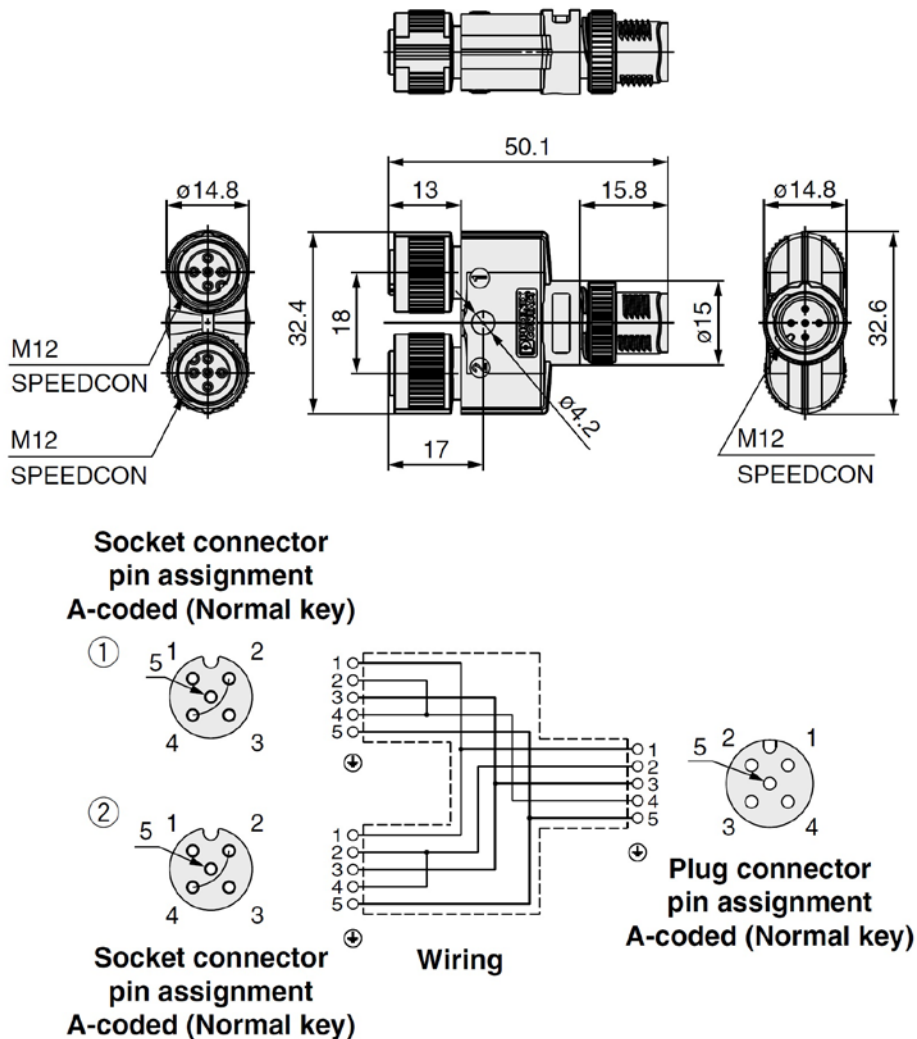
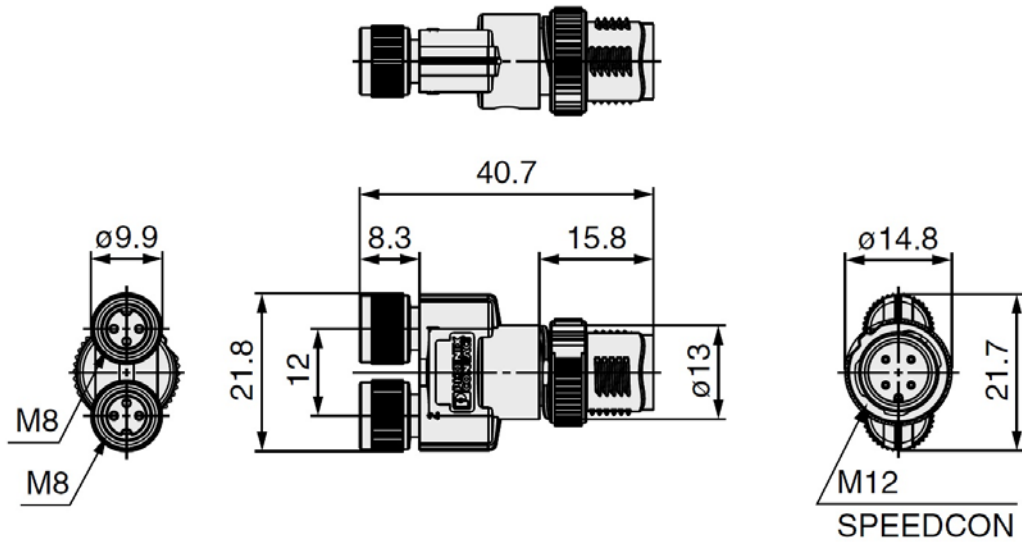

Fig. 10-2 PCA-1557785

Model No.: PCA-1557798

(Y branch Connector (2 x M8 to M12))



**Socket connector
pin assignment**

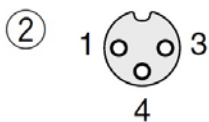
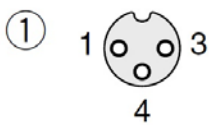

**Socket connector
pin assignment**

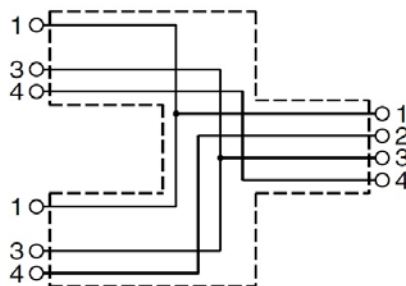

Wiring

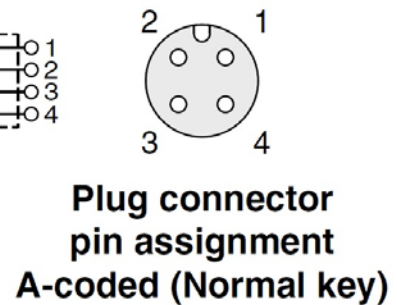

Fig. 10-3 PCA-1557798

10.3. Seal cap

Seal caps can be used with the EX245-DX1 and EX245-DY1.
Mount the seal cap in the unused socket.
IP65 is satisfied by using the seal cap properly.

Model No.: EX9-AWTS
(M12 connector for socket 10 pieces.)

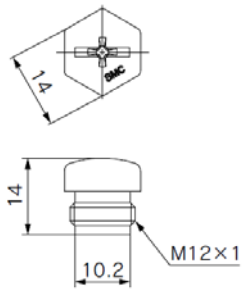

Fig. 10-4 EX9-AWTS

Note: Tighten the seal caps to the tightening torque specified (0.2 N•m).

Model No.:EX245-AWP

(10 pieces for Push Pull connectors of power connection)

The EX245-AWP can be used with the EX245-SPN1/EX245-SPN2.
Mount the seal cap in the unused connector.
IP65 rating is maintained by using the seal cap properly.

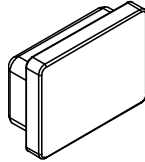

Fig. 10-5 EX245-AWP

Model No.:EX245-AWC

(10 pieces for Push Pull connectors of PROFINET connection)

The EX245-AWC can be used with the EX245-SPN1/EX245-SPN2.
Mount the seal cap in the unused connector.
IP65 rating is maintained by using the seal cap properly.

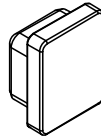

Fig. 10-6 EX245-AWC

NOTE

- In case of the EX245-SPN1 or EX245-SPN2, the Seal caps is fitted to all bus & power connector when shipped from factory.

10.4. Joint pack

One "Joint assembly" and two "Modular adaptor assembly" are contained in one "Joint pack".

Model No.: EX245-ZJP

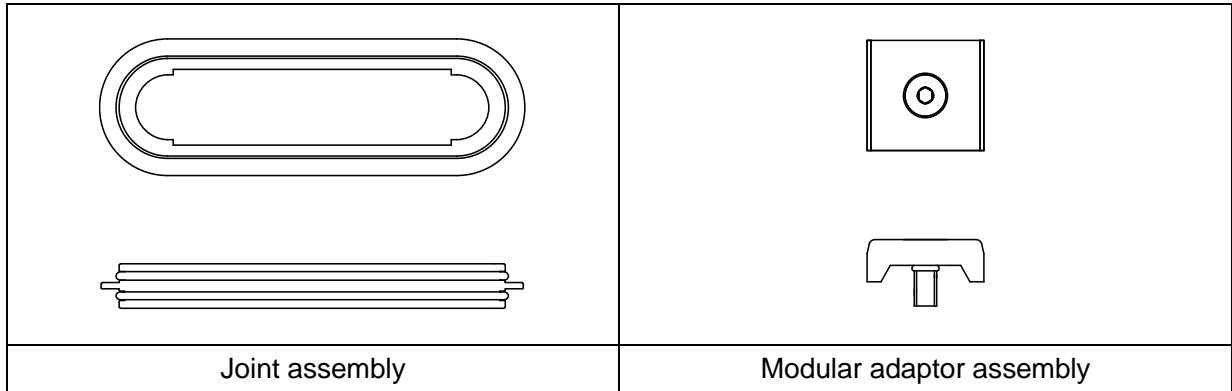

Fig. 10-7 EX245-ZJP

NOTE

- One Joint pack is attached to the EX245-DX1, EX245-DY1 and EX245-EA2-1/2.
- Regarding mounting, refer to the [Section 3.1.2](#).

11. Dimensions

11.1. I/O Modules Manifold

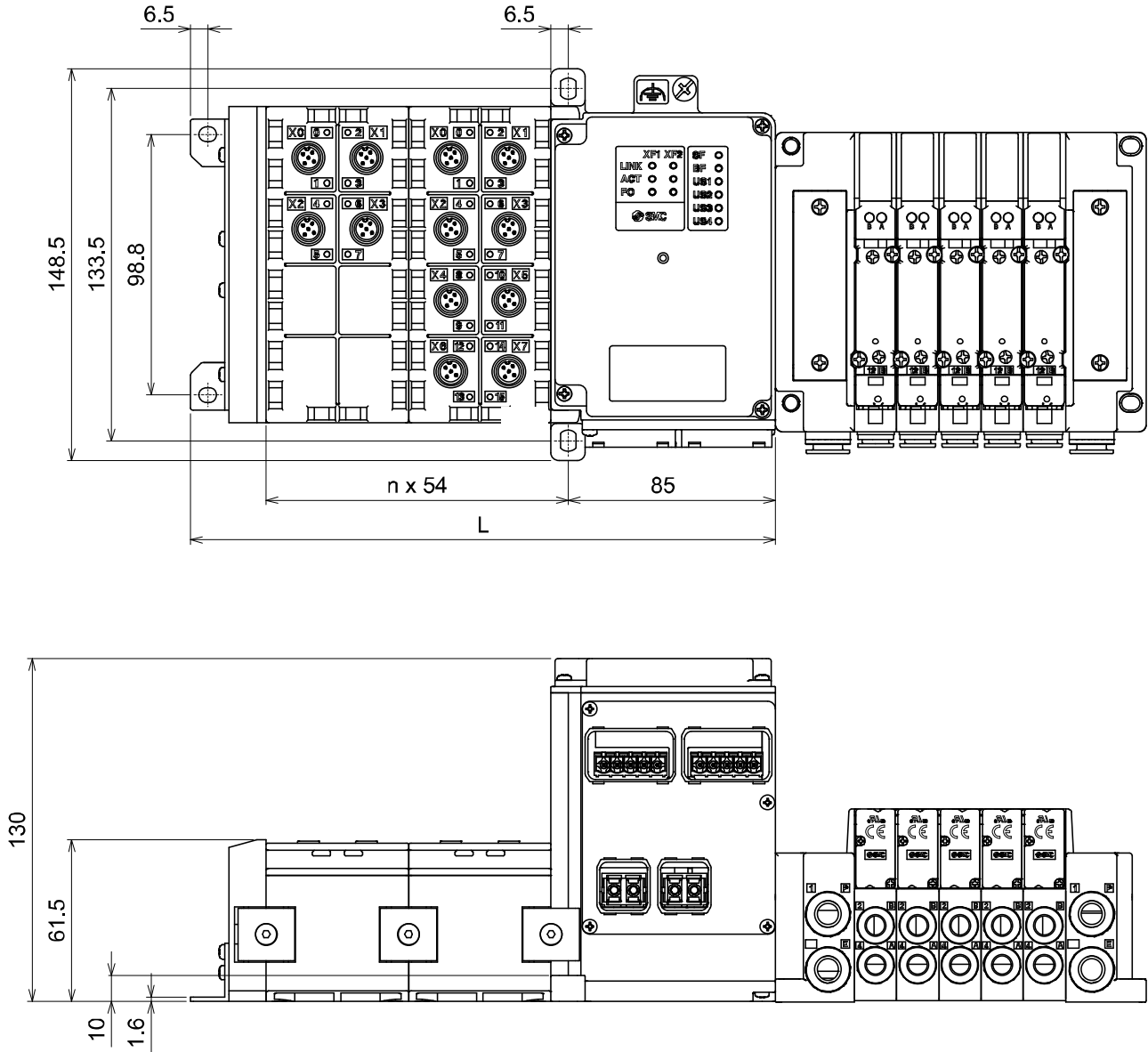

Fig. 11-1 Dimensions of the Modules manifold

The following table shows the length of the I/O Modules manifold.

Table. 11-1 Length the EX245 series module

n	0	1	2	3	4	5	6	7	8
L	113.6	167.6	221.6	275.6	329.6	383.6	437.6	491.6	545.6

Formulas: $L = 54n + 113.6$ (max. 8 modules) (Dimensions in mm)

12. Troubleshooting

12.1. EX245-SPN1/SPN2

Table. 12-1 Troubleshooting for bus communication

No.	Problem	Possible cause	Remedy
1	<ul style="list-style-type: none"> LINK indicator is OFF. ACT indicator is OFF. 	<ul style="list-style-type: none"> The SI Unit is not connecting to any bus. 	<ul style="list-style-type: none"> Check the cable connection.
2	BF indicator is ON.	No bus communication.	<ul style="list-style-type: none"> Check the cable. Connect to the PROFINET bus communication.
3	BF indicator flashes.	The SI Unit is physically connected to the IO Controller but the following problem has occurred.	---
		<ul style="list-style-type: none"> Configuration is defective. 	<ul style="list-style-type: none"> Check the configuration.
		<ul style="list-style-type: none"> Device name is not correct. 	<ul style="list-style-type: none"> Check the device names.
		<ul style="list-style-type: none"> The IO Controller is defective. 	<ul style="list-style-type: none"> Check the IO Controller.

Table. 12-2 Troubleshooting for the problem with display on SF LED

No.	Problem	Possible cause	Remedy
1	<ul style="list-style-type: none"> SF indicator is flashes at 2 Hz.s 	The connection to the IO controller is OK but the following diagnostic event occurred.	Check the diagnostic event.
2	<ul style="list-style-type: none"> SF indicator is flashes at 2 Hz.s 	At least one valve coil has a short circuit.	Check the solenoid valve for a short circuit.
		At least one connected module has a short circuit.	Check the module error.
3	SF indicator is ON.	The following diagnostic event occurred.	Check the diagnostic event.
		<ul style="list-style-type: none"> The configuration data sent by the IO Controller does not match the actual layout. (ex: The "EX245 PN Cu" folder is selected (drag & drop) onto the PROFINET line on the PN master in the "HW Config" on the STEP 7.) 	<ul style="list-style-type: none"> Check the configuration of the SI Unit and the module layout. (Check the configuration in the "HW Config" on the STEP 7 and change the configuration from "EX245 PN Cu" to "EX245 PN FX" folder.)
		<ul style="list-style-type: none"> One of the "Valves" modules is not set in Slot 1 or Slot 2 in your configuration program. 	<ul style="list-style-type: none"> Check the configuration of the SI Unit. (Refer to Section 4.1)
		<ul style="list-style-type: none"> Power supply is not present or is below the dropout level. 	<ul style="list-style-type: none"> Check the power supply.
		<ul style="list-style-type: none"> At least one valve coil has a short circuit and at least one connected module has a short circuit or the module layout has changed. 	<ul style="list-style-type: none"> Check both the solenoid valve for a short circuit and the module error/layout.
		<ul style="list-style-type: none"> A connected module is defective. 	<ul style="list-style-type: none"> Check the connected module.
		<ul style="list-style-type: none"> The strength of the fiber-optic communication is less than 2 dB. 	<ul style="list-style-type: none"> Check the fiber-optic cable.
		<ul style="list-style-type: none"> The module layout has faulty. 	<ul style="list-style-type: none"> Check the module layout.

Table. 12-3 Troubleshooting for the problem with display on US1/2 LED

No.	Problem	Possible cause	Remedy
1	US1 indicator is OFF.	Incorrect wiring.	<ul style="list-style-type: none"> • Check the cable. • Check the wiring and pin numbers.
		US1 is not present or below the dropout level (< approx. 17 VDC).	Check the supply for the logic/sensors of SI unit.
2	US1 indicator is flashing.	US1 is below the permissible level but above the dropout level (17 to 21.6 VDC).	Check the supply for the logic/sensors of SI unit.
3	US2 indicator is OFF.	Incorrect wiring.	<ul style="list-style-type: none"> • Check the cable. • Check the wiring and pin numbers.
		US2 is not present or below the dropout level (< approx. 17 VDC).	Check the supply for the valves/loads.
4	US2 indicator is flashing.	US2 is below the permissible level but above the dropout level (17 to 22.8 VDC).	Check the supply for the valves/loads.

Table. 12-4 Troubleshooting for malfunction of the solenoid valve

No.	Problem	Possible cause	Remedy
5	A solenoid valve is not operating.	Incorrect connection.	Check the connection with the SI Unit.
		Solenoid valve is faulty.	Check the solenoid valve.
		US2 is not present or below the dropout level (< approx. 17 VDC).	<ul style="list-style-type: none"> • Check the supply for the valves. • Check the wiring and pin numbers.

12.2. EX245-DX1

Table. 12-5 Troubleshooting for EX245-DX1

No.	Problem	Possible cause	Remedy
1	Signals cannot be received even with sensor.	Incorrect wiring.	Check the wiring and pin numbers.
		US1 is not present or below the dropout level (< approx. 17 VDC).	Check the supply for the sensors.
		Sensor is faulty.	Check the sensor.
2	Status indicator is red ON.	Connector has a short circuit.	<ul style="list-style-type: none"> • Check the wiring and pin numbers. • Check the sensor.

12.3. EX245-DY1

Table. 12-6 Troubleshooting for EX245-DY1

No.	Problem	Possible cause	Remedy
1	A load is not operating.	Incorrect wiring.	Check the wiring and pin numbers.
		US2 or additional supply for the loads is not present or below the dropout level (< approx. 17 VDC).	Check the (additional) supply for the loads.
		Load is faulty.	Check the load.
2	Status indicator is red ON.	Output has a short circuit.	<ul style="list-style-type: none"> • Check the wiring and pin numbers. • Check the load.

Revision history
A: Contents are added [September 2020]

SMC Corporation

4-14-1, Sotokanda, Chiyoda-ku, Tokyo 101-0021 JAPAN
Tel: + 81 3 5207 8249 Fax: +81 3 5298 5362
URL <https://www.smcworld.com>

Note: Specifications are subject to change without prior notice and any obligation on the part of the manufacturer.
© 2017-2020 SMC Corporation All Rights Reserved

