



Operation Manual

Air Cooled Thermo-con (Compact type)

INR-244-831



1 Read Before Using

Thank you for purchasing SMC's Thermo-con (hereinafter referred to as the "product"). This "Operation Manual" (hereinafter referred to as "this manual") briefly explains the essential safety instruction procedures to start and stop the product and reset its alarms. Read this manual before using.

2 Safety Instructions

This manual contains essential information for the protection of users and others from possible injury and/or equipment damage.

- Read this manual before using the product, to ensure correct handling, and read the manuals of related apparatus before use.
- Keep this manual in a safe place for future reference.
- These instructions indicate the level of potential hazard by label of "Caution", "Warning" or "Danger", followed by important safety information which must be carefully followed.
- To ensure safety of personnel and equipment the safety instructions in this manual and the product catalogue must be observed, along with other relevant safety practices.

	Caution	If instructions are not followed there is a possibility of injury or equipment damage.
	Warning	If instructions are not followed there is a possibility of serious injury or loss of life.
	Danger	In extreme conditions, there is a possibility of serious injury or loss of life.

- This manual provides the following symbols in addition to "Danger", "Warning", and "Caution" to present warning details in an easy-to-understand manner.

	This symbol warns you of potential electrical shock.
	This symbol warns you of potential burns.

Danger

- During operation or maintenance of the product, do not disable the interlock function of any device. Otherwise unexpected personnel injury or damage to the product may occur.
- When turning on/off the power observe the procedure. Otherwise unexpected malfunction or danger may occur.
- When maintaining, cleaning or in case of emergency, turn off the power source.
- After identifying a problem be sure to check the cause and take necessary countermeasures before turning on the power.
- The product is operated at high voltage.

Warning

- **The compatibility of equipment is the responsibility of the person who designs the system or decides its specifications.**
Since the products specified here can be used in various operating conditions, their compatibility with the specific system must be based on specifications or after analysis and/or tests to meet specific requirements.
- **Only trained personnel should handle or operate the product.**
Transportation, installation and maintenance of the product can be dangerous and should be done by persons who have full knowledge and experience on the product and system. Cover panels of the product should be opened only by qualified service technicians or qualified personnel.
- **Do not modify or reconstruct the unit.**
- **Do not service machinery/equipment or attempt to remove components until safety is confirmed.**

2 Safety Instructions Continued

- 1) Inspection and maintenance of machinery/equipment should only be performed after confirmation of safe locked-out positions.
 - 2) When equipment is to be removed, confirm the safety process as mentioned above. Switch off electrical supplies and ensure any high temperature parts have cooled to ambient temperature.
 - 3) Before machinery/equipment is re-started, ensure all safety measures are taken so the product and system can be started in a safe manner.
 - 4) Do not use this product outdoor (indoor use).
- **Do not use this product outside of the specifications. Contact SMC if it is to be used in any of the following conditions.**

- 1) Conditions and environments beyond the given specifications.
 - 2) Installations in conjunction with atomic energy, railway, air navigation, vehicles, medical equipment, food and beverage, recreation equipment, emergency stop circuits, press applications, or safety equipment.
- If abnormal conditions occur, such as abnormal noise or smoke, or water leakage, take the following actions.
- 1) Shut down power.
 - 2) Contact an authorised SMC dealer for repair.

Caution

- After shutting down the power supply, ensure a time interval at least 3sec between ON and OFF. Restarting the product within that interval may cause it to malfunction.
- Do not use devices that generate electromagnetic radiation such as cellular phones near the product. There is a possibility that this can cause the product to malfunction.
- This unit has several interlock functions, which activate when a dangerous operation or condition occurs to stop the product and make it safe. This is a function to protect personnel and restrict operation that may cause damage to the product or facility, and to remove dangers related to safety.
- When dispose the product, contact an industrial waste disposal company for disposal of the product. To minimize the risk, drain the fluid from the product when it is scrapped. If the fluid is left inside, an accident and damage can result during transportation.
- When the circulating fluid temperature is low, do not operate it at a low flow rate. It may freeze circulating fluid in the product when used at low temperature and low flow rate.
- This unit does not use parts that meet the SCCR specifications.

3 Specifications

3.1 General Description and Intended Use

This product uses a built in pump to circulate liquid (water or 20% EG) at a constant temperature, controlled by Thermo-Electric (Peltier) Modules. This circulating fluid cools parts of the customer's machine that generates heat.

3.2 General Specifications

Item	Spec.
Operation temp. range	10.0 to 60.0 °C (No dew condensation)
Ambient environment	Temperature: 10 to 35 °C Humidity : 35 to 70%RH Altitude : up to 2000m Environment : No corrosive gas, solvent such as thinner and flammable gas
Storage environment	Temperature : -40 to 70 °C (No dew condensation and icing) Humidity : 5 to 95%RH Environment : No corrosive gas, solvent such as thinner and flammable gas
Accuracy related to temp	Indication accuracy: +/- 0.2 °C (Set temperature 25°C and ambient temperature 25°C) Temperature drift: +/- 0.2°C Stability: +/- 0.01 to 0.03 °C (Circulating fluid OUT is directly connected with IN)
Cooling capacity	Approx. 220W (Flow rate 1L/min, set temperature 25°C and ambient temperature 25°C)
Circulating fluid	Water, Ethylene glycol solution up to 20%
Tank capacity	Approx. 110mL
Pump capacity	Refer to performance chart.
Port size	IN/OUT: Rc1/4
Wetted materials	Stainless steel, EPDM, NBR, Ceramic, PPE, PPS, Carbon, PP, POM
Power supply	DC24V +/- 10%
Current consumption	12.5A (Peak current 18A)
Insulation resistance	50MΩ or more (DC500V)
Over voltage category	Category I
Pollution degree	Pollution degree II
Limitation of hazardous substance	RoHS compliant products
Acoustic noise	58dBA (Low noise fan option: 45dBA)
Cooling method	Air cooled
Main functions	Offset function, Setting value memory function, Communication,
Input operation and indications	Key sheet / LCD display with LED backlight
Communications	RS-485 Communications: Reading of measured temperature, Setting and reading of target temperature, Setting and reading of offset value, Storage of set value, Setting and reading of control mode. For operation by communication, it is necessary to order "Communication Manual". Use shielded cable for serial communications.

3 Specifications Continued

Item	Spec.
Mass (at dry)	Approx. 4.5kg
Option	High pressure pump, Low noise fan
Contents of package	Thermo-con 1pc Operation Manual 1pc Power supply cable (1m, 16AWG, with Ferrite core) 1pc Filter cover (with air filter) 1pc

3.3 Performance Charts

Values on the performance charts are not guaranteed values but representative values. Allow margins for safety when selecting the model

3.3.1 Cooling Capacity

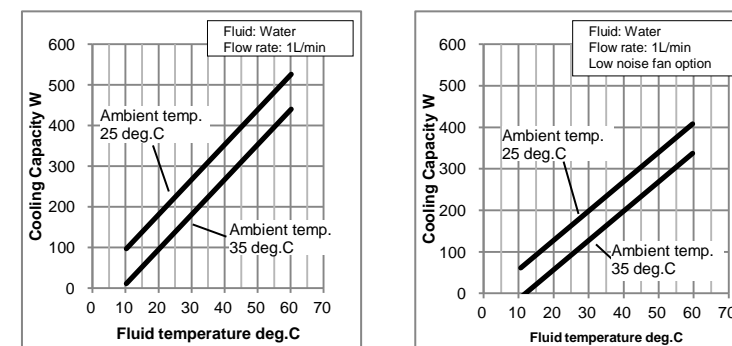

*Cooling capacity decrease approx. 20W when high pressure pump option selected

3.3.2 Heating Capacity

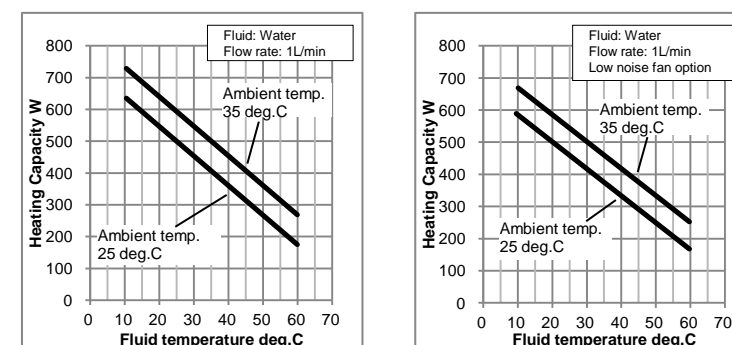

*Heating capacity increase approx. 10W when high pressure pump option selected

3.3.3 Pump Capacity

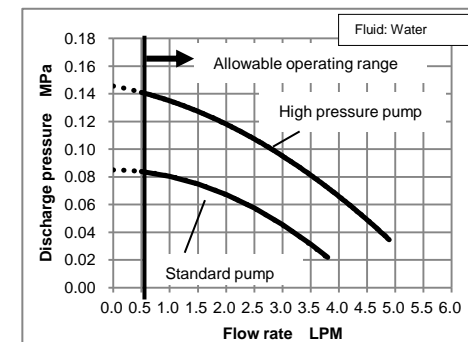

3.4 Connector Specifications

Description	No.	Signal	Style and Part No.
Power supply connector	1	DC24V+	 1 2 J.S.T. Mfg. JFA connector J4000 series SC02B-J42SK-GHXR
	2	DC24V-	
Communication connector	1	RS-485 BUS +	 5 4 3 2 1 9 8 7 6 D-sub 9 pin (socket type) Fixed screw: M2.6
	2-8	Unused	
	9	RS-485 BUS -	

3 Specifications Continued

3.5 Model number of product

The product can be ordered with the model number configured as shown below.

INR - 244 - 831



Option

	Nil	None
- X125	High pressure pump	
- X126	Low noise fan	
- X127	High pressure pump Low noise fan	

3.6 Product serial number code

The production serial number code printed on the label indicates the year and month of production as per the following table:

Year	Month						
	2020	2021	2022	2023	2024	2025
Jan	o	yo	Zo	Ao	Bo	Co	Do
Feb	P	yP	ZP	AP	BP	CP	DP
Mar	Q	yQ	ZQ	AQ	BQ	CQ	DQ
Apr	R	yR	ZR	AR	BR	CR	DR
May	S	yS	ZS	AS	BS	CS	DS
Jun	T	yT	ZT	AT	BT	CT	DT
Jul	U	yU	ZU	AU	BU	CU	DU
Aug	V	yV	ZV	AV	BV	CV	DV
Sep	W	yW	ZW	AW	BW	CW	DW
Oct	X	yX	ZX	AX	BX	CX	DX
Nov	y	yy	Zy	Ay	By	Cy	Dy
Dec	Z	yZ	ZZ	AZ	BZ	CZ	DZ

4 Special Features

- **Offset function**
This function controls the temperature slide by an offset value from set point temperature. When the circulating fluid travels to the target object, a certain deviation occurs between the temperature just before the object and the set temperature of the product due to the influence of ambient temperature on the piping. In this case, if the deviation is input as the offset value, the temperature of the circulating fluid just before the object can match with the setting value. Internal sensor value for the alarm does not include the offset value. For example, if 0.1 °C is set here, the actual reference temperature for control is lower than the indicated SV by 0.1 °C.
- **Setting value memory function**
Even if the power is turned off the set values are saved and will be restored at power on.

5 Installation

5.1 Installation

Caution

- Pay special attention to the safety of all personnel when installing and transporting the product.
- Do not install the product unless the safety instructions have been read and understood.
- Leakage from the product may damage peripheral equipment. Install a drain pan under the product to capture leakage. Furthermore, mount devices like a leak sensor on the installed drain pan to detect leakage so that it can alert operators around the area.

5.2 Environment

Caution

- Do not use in an environment where the product is directly exposed to water, oil, corrosive gases, chemicals, salt water or steam.
- The product should be installed upright on a stable base.
- Do not install the product in a location where the air inlet and air outlet vents are blocked. Also do not use the product in a sealed enclosure.
- Do not use in an explosive atmosphere.
- Do not mount the product in a location where it can be exposed to prolonged sunlight. Use a protective cover.
- Do not mount the product in a location where it is subject to strong vibrations and/or shock. Check the product specifications.
- Do not use the product where it can be exposed to strong electrical or magnetic emissions.
- Do not mount the product in a location where it is exposed to noise sources (such as discharging equipment, large relay and thyristor).
- Do not mount the product in a location with an altitude of more than 1000 meters.
- Do not mount the product where it is exposed to materials such as silicone, which may generate harmful gas.
- Install the product in a location where the ambient temperature range is between 10 to 35°C and the relative humidity range is between 35 to 70%. No dew condensation is allowed on the unit.
- Do not mount the product in a location exposed to radiant heat.

5.3 Filter cover and Air filter

- Ensure that the power source and the power supply of the product are turned off (or the power plug must come off).
- Loosen the product screws (2 places). Attach the included filter cover and air filter (hook the protruding part of the filter cover on the product) and tighten screws to the required torque (M3: 0.63Nm).

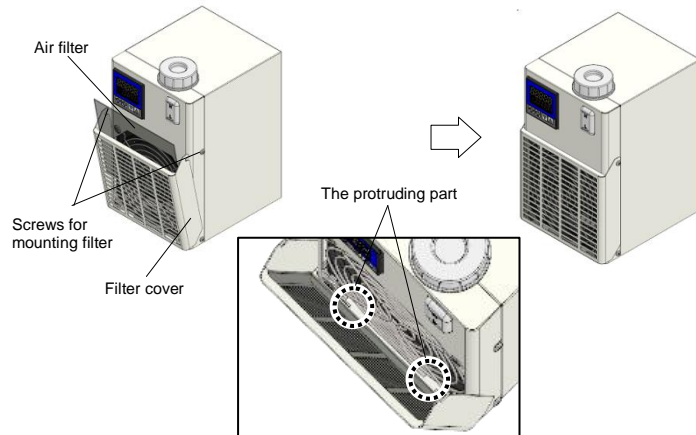

5.4 Piping

- Ensure that the power source and the power supply of the product is turned off (or the power plug must come off).
- Ensure the flow rate of the circulating fluid is as high as possible to maintain the temperature stability. Therefore, the length of the external piping should be minimized and internal diameter should be as large as possible. Piping must have sufficient strength for the maximum discharge pressure of the circulating circuit.
- Likewise, if a tube is bent or multiple elbow fittings are used, the piping resistance will increase and the flow rate will decrease. If the flow rate falls, the temperature stability will decrease.
- If installing a tank externally, only a sealed tank should be used. Do not use an open tank.

5 Installation Continued

Caution

- Ensure that the INLET and OUTLET for circulating fluid is connected correctly. If any valves are used ensure that they do not restrict the flow, otherwise low flow may cause an alarm.
- When installing piping or fittings, ensure sealant material does not enter inside the port. When using seal tape, leave 1.5 to 2 threads exposed on the end of the pipe/fitting.
- Be sure to correctly tighten the fittings to the required torque(Rc1/4:12 to 14 N·m).

5.5 Wiring

- This product may use maximum current of 18A, depending on the operating conditions. Select the power source with some margins.
- Ensure that the power source and the power supply of the product is turned off before connecting the various connectors and power supply cable.
- Supply disconnecting device according to IEC60947-3 for the product must be provided in the end system.
- Do not install the disconnecting device in the place where the operation is difficult. And also the switch of the disconnecting device must comply with the direction of the switch specified by IEC60447.
- Ensure that a lock out facility is available on the power source. Ensure that an Earth Leakage Breaker with proper capacity is used. Install it above 0.6m from the floor.
- Use the dedicated power supply for this product with SELV.
- Preparation and wiring of power supply cable
 - Attach the proper connector (e.g. crimped terminal) that matches the power source to one end of accessory power supply cable. (Accessory cable: 16AWG, UL1007)
 - Connect the connector to the power source, and the product.
- Ensure that there is enough space between the power supply cable and the communication cable of the product and power cables of other equipment.
- Ensure the power supply and ground (protective earth) connections are made correctly.
- Be sure to provide the grounding (16AWG). Do not connect the ground in

common with the ones for equipment that generates strong electromagnetic noise or high frequency.

- Connect the host to this unit with a twisted pair shield cable when applying communication function. When using the Communication connector, connect the circuit separated from the mains circuit by reinforced insulation.
- Ensure that external instruments connecting to this product provide the enclosure complied with UL61010-1 and use the cable which provides flame resistance (over VW-1).

5.6 Filling the product

- Ensure that the power source and the power supply of the product are turned off (or the power plug must come off).
- Remove the reservoir cap.
- If using Ethylene Glycol, refer to the suppliers Material Safety Data Sheet (MSDS) and wear Personal Protective Equipment (PPE) as appropriate.
- Fill the circulating fluid into the reservoir. Stop filling once the level of fluid reaches the "H" mark.
- Turn on the power switch to fill the piping with the fluid.
- When the piping is filled with the circulating fluid, the level of the reservoir decreases and low fluid level alarm arises accordingly. Then, turn off the power supply once again.
- Repeat the step from 4 to 6 until alarm doesn't appear anymore.
- Then, replace the cap on the reservoir and tighten it securely.
- Keep the fluid level between H and L of the level indicator

Danger

- Never touch the power switch with wet hands to avoid electrical shock.

Caution

- Do not touch the surface when the set temperature is high. Temperature of the tank and the chassis near the tank could be high.
- Fluid other than water or Ethylene Glycol (up to 20%) should not be used as circulating fluid. Using such fluid may lead to leakage or damage of the pump.
- Operation of the pump with a large amount of air left in the piping for prolonged period may damage the pump. Remove air from piping before starting operation.
- If the power switch is turned on without circulating fluid, the pump could be damaged.

5 Installation Continued

- Take care not to spill water over the product when supplying water to the reservoir. When a spill is made, wipe it off immediately and only supply power after it has dried. If this procedure is neglected, it may cause damage to the product.
- If a fluid with low conductivity such as DI water is used as circulating fluid, it can cause static electricity due to friction and damage the product. Take measures to minimize the static electricity from circulating fluid.
- Do not use with flow rate of circulating fluid is zero. If the flow rate is zero, the temperature of circulating fluid cannot be detected and might be increased or decreased. The pump might be broken as well.

6 Operation

6.1 Power Up

When power is turned on, the controller setting number is indicated on display panel for approx. 4 seconds.

6.2 Operation

The product begins operation immediately after the power is turned on. The pump, fan and heat exchanger will be running and the product will begin temperature control.

6.3 Details of Controller/Display

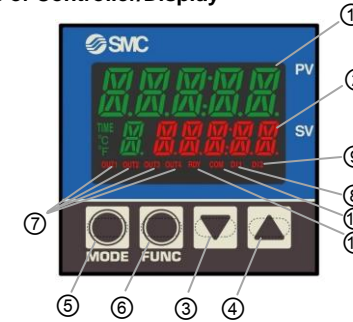

No.	Description	Detail
①	Display1	Displays characters indicating temp. control or setting content.
②	Display2	Displays set temperature or each selected input value.
③	[▼] key (DOWN key)	Decreases set data.
④	[▲] key (UP key)	Increases set data.
⑤	[MODE] key	Used to change screens and modes.
⑥	[FUNC] key	Used to shift digits of SV
⑦	Output LED	OUT1: Lights up during heating. OUT2: Lights up during cooling. OUT3,4: Lights up when pump and fan are stopped.
⑧	Alarm(DI1) LED	Lights up Level switch alarm occurs.
⑨	Alarm(DI2) LED	Lights up thermostat alarm occurs.
⑩	Communication LED	Flashes during communication. Normally, it remains on.
⑪	RDY LED	Lights up when temp. control, pump and fan are stopped.

6.4 Settings

Controller has two modes, Operation mode and Setting mode. Each mode has the following contents.

Operation Mode: Initial mode

Used in normal operation (e.g. setting of target temperature/offset.)

Setting Mode: Press and hold [MODE] key for 2 seconds.

Used at maintenance and initial setting for controller/PID/Communication.

- Setting of functions and data in each mode
 - Press [MODE] key in each mode to select the required function.
 - Increase or decrease data with the [▲] or [▼] key
 - Each press of the [▲] key increases the data by one count.
 - Each press of the [▼] key decreases the data by one count.
 - Holding the [▲] or [▼] key accelerates the increase or decrease.

6 Operation Continued

Turn on the power

Operation mode

[MODE] key	Function
→	Target / Measured Temp. Indication and setting
PV51	Offset setting
MV1	Heating output indicator
MV2	Cooling output indicator

Press and hold [MODE] key for 2 sec

Setting Mode

<SET4> Control setting mode [MODE] key		[▼][▲] key		<SET17> Communication setting mode [MODE] key	
Md	Control Mode	CoM	Communication parameter	bP5	Communication speed
P1	Heating proportional band	AdR	Communication address	RdE	Response delay time
I	Integral time				
d	Derivative time				
t1	Heating proportional cycle				
ARW	ARW				
P2	Cooling proportional band				
t2	Cooling proportional cycle				

6 Operation Continued

6.4.1 Operation Mode

When the power supply switch is turned on, the product is in operation mode. The target temperature is shown as well as the current measured temperature. Each presses of the [MODE] key changes the operation mode display as follows.

No.	Modes	Function	Setting range (Min. increment)	Default
1	Target Temp./ Measured Temp. Indication and setting	Sets target temperature Set with [▲] or [▼] key	10.0 to 60.0°C (0.1°C)	25.0

2	Offset Setting	Sets the offset value of the PV. Set with [▲] or [▼] key Ex. If set to 0.5, the temperature is controlled to a value that is 0.5°C lower than displayed temperature (PV).	-9.9 to 9.9°C (0.1°C)	0
3	Heating output indicator	Indicate the heating output ratio	0.0 to 100.0%	-
4	Cooling output indicator	Indicate the cooling output ratio	0.0 to 100.0%	-

6.4.2 Setting Mode

Setting mode can be shown by pressing and holding the [MODE] key for approx. 2 sec.

Pressing the [MODE] key for approx. 2 sec again will return the setting mode to the Operation mode.

Setting mode selection is indicated with "SEt" and the required setting mode can be selected by increasing or decreasing the indicated number with the [▲] or [▼] key

SEt04	Function	Selects mode for each setting. Select with [▲] or [▼] key.
0 Cnt	Selectable setting	4, 17 4: Control Setting Mode 17: Communication Setting Mode

6 Operation Continued

SET4: Control Setting Mode

Selecting "04" in Setting mode "SEt" activates the control setting mode. Each presses of the [MODE] key changes the operating mode as follows.

No.	Modes	Function	Selectable Setting	Default
1	Control Mode Setting PV: Md SV: 0 RUN	Sets control mode. Select with [▲] or [▼] keys	RUN : Temperature control and pump/fan operation enabled RdY : Temperature control and pump/fan operation disabled	RUN
2	Heating Proportional Band Setting PV: P1 SV: 0 0.5	Sets the proportional band for heating. Set with [▲] or [▼] key This range is a percentage of temperature setting range.	0.1 to 200.0 %	7.5%
3	Integral Time setting PV: I SV: 0 20	Sets the integral time. Set with [▲] or [▼] key	0 to 3600 sec. If "0" is set, integral control is disabled.	20sec
4	Derivative Time Setting PV: d SV: 0 0	Sets the derivative time used for PID control. Set with [▲] or [▼] key	0 to 3600 sec. If "0" is set, derivative control is disabled.	0sec

5	Heating Proportional Cycle Setting PV: t1 SV: 0 1.0	Sets heating proportional cycle. Set with [▲] or [▼] key	0.1 to 120.0 sec If the proportional cycle is set at 1 sec. and Heating Output is 70%, the output will be 0.7 sec. ON and 0.3 sec. OFF.	1.0sec
6	ARW Setting PV: ARW SV: 0 100.0	Sets anti-reset wind-up. Set with [▲] or [▼] key	0.0 to 110.0 % Reduces overshoot in PID control due to integrating operation. The integration operation is not performed above the set value. The set value must be higher than the output at stable control.	100.0%
7	Cooling Proportional Band Setting PV: P2 SV: 0 0.50	Sets cooling proportional band for cooling. Set with [▲] or [▼] key	0.10 to 10.00 times.	0.50 times of P1 set value
8	Cooling Proportional Cycle Setting PV: t2 SV: 0 1.0	Sets cooling proportional cycle. Set with [▲] or [▼] key	0.1 to 120.0 sec If the proportional cycle is set at 1 sec. and Cooling Output is 70%, the output will be 0.7 sec. ON and 0.3 sec. OFF.	1.0sec

6 Operation Continued

SET17: Communication Setting Mode

Selecting "17" in Setting mode "SEt" activates the control setting mode. Each presses of the [MODE] key changes the operating mode as follows.

No.	Modes	Function	Selectable Setting	Default
1	Communication parameter setting PV: COM SV: NBN2	Sets communication parameters	1 st digit: Stop bit length 1 or 2 1: 1 bit, 2: 2 bit 2 nd digit: Parity check N, O or E N: None, O: Odd, E: Even 3 rd digit: Data length 7 or 8 7: 7 bit, 8: 8 bit 4 th digit: BCC check N or b N: Disable, b: Enable The number of digits is counted from the right side.	NBN2
2	Communication speed setting PV: bPS SV: 9.6	Sets the communication speed. The set value can be scrolled with the ▲ and ▼ keys. 2.4 ⇔ 4.8 ⇔ 9.6 ⇔ 19.2 ⇔ 38.4	2.4 ~ 38.4 (2400 bps ~ 38400 bps)	9.6 (9600 bps)
3	Communication address setting PV: AdR SV: 1	Sets the communication address of the product. Set with [▲] or [▼] key	1 to 99 addresses	1
4	Response delay time setting PV: Awt SV: 0	Sets the response delay time. Set with [▲] or [▼] key	0 to 250 ms	0ms

7 Outline Dimensions (mm)

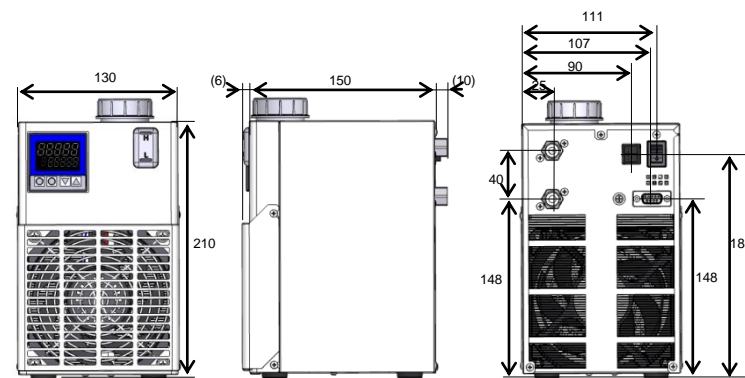

8 Key Parts

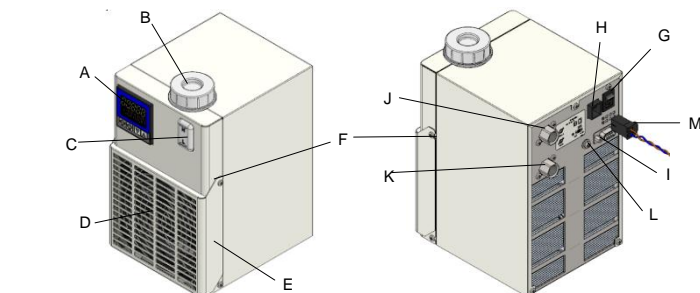

A	Display/Operation panel	G	Main power switch
B	Reservoir Cap	H	Power supply connector
C	Level gauge	I	Communication connector
D	Air filter (air inlet)	J	Circulating fluid OUT (Rc1/4)
E	Filter cover	K	Circulating fluid IN/Drain (Rc1/4)
F	Screws for filter maintenance	L	PE connector(M4)
		M	Power supply cable (Accessory, with Ferrite core)

9 Maintenance

9.1 Daily Check

- 1) Indication of display panel: Check temperature condition and confirm whether or not an alarm has occurred.
- 2) Confirm that the panel, heat sink and filter are free from dust. A large amount of dust may impair the performance.
- 3) Confirm there is no leakage of circulating fluid and check the condition of the piping (e.g. no tight bends or crushed pipes).
- 4) Confirm there is no abnormal sound, smell or heating from the product.

Caution

- When cleaning the panel, heat sink, filter use a vacuum cleaner to remove the dust. Do not use water or steam since it leads to rusting of the frame.

9.2 General Maintenance

Replace the circulating fluid regularly to avoid any problems due to algae or contamination.

<Drain circulating fluid>

1. Drain circulating fluid from the circulating fluid IN port. Loosen the reservoir cap to help draining. (Do not remove the cap)
2. To drain from the piping, blow air (0.05MPa, about 1 minute) from the circulating fluid OUT to IN port. Close the reservoir cap while blowing.

Clean air filter periodically to avoid declining performance.

<Clean air filter>

1. Loosen the screws (2 places), open the filter cover and remove the filter.
2. Clean the filter, then put it back to the product.

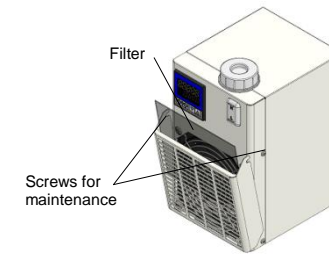

Caution

- The repair and maintenance services of this unit are performed only at SMC factory. SMC does not provide on-site repair or maintenance service in a national or overseas situation.
- It is recommended to prepare spare units to minimize downtime due to those repair and maintenance services.
- Drain the fluid from the product when it is returned for the repair and maintenance service. If the fluid is left inside, an accident and damage can result during transportation.
- Do not make any modification to the product.
- Do not disassemble the product, unless required by installation instructions.
- If fluid other than water is used, wash the circulating fluid circuit with water or DI water before returning the product to SMC. Products that have not been washed may not be accepted at the factory.

10 Troubleshooting

10.1 Alarm list

Display1,2	Content of alarm	Display Small LED	Product Status	Reset
Normal status	Low level alarm Occurs when liquid level is low	OUT3 OUT4 RYD DI1	Temp. control pump and fan stop	Turn ON Main power switch again
Normal status	Thermostat alarm Occurs when the thermostat that detects excessive heating begins operating.	OUT3 OUT4 RYD DI2	Temp. control pump and fan stop	Turn ON Main power switch again
Err0	Memory error Occurs when the data stored inside of the EEPROM breaks.	-	Temp. control pump and fan stop	Turn ON Main power switch again
Err1	Controller error Occurs when A/D conversion is not performed properly.	-	Temp. control pump and fan stop	Turn ON Main power switch again
	High temp. sensor value Occurs when the temperature sensor breaks.	-	Temp. control stop	Turn ON Main power switch again
	Low temp. sensor value Occurs when the temperature sensor is short-circuited.	-	Temp. control stop	Turn ON Main power switch again

10.2 Troubleshooting

Code	Cause	Countermeasure
DI1 (Small LED)	Level Switch	Fluid level of the tank is not enough Refill tank with fluid
		Fluid is leaking Check all fluid connections connected with the product.
DI2 (Small LED)	Thermostat	Flow rate is zero. If flow rate of circulating fluid is zero, the temperature of the fluid cannot be measured and the temperature of heat exchanger or heatsink may increase. Ensure the circulating fluid is allowed to flow.
		The pump breaks. Check the pump operation. If the pump breaks, need to be replaced.
		Ambient temperature is too high. (out of 10-35°C) Correct the ambient temperature within the specification range.
		Filter clogged Clean the filter.
	The fan breaks Check the fan operation. If the fan breaks, need to be replaced.	

ERR0	The EEPROM of Controller is broken due to high-level electric noise.	If the trouble cannot be solved even after restart, controller need to be replaced.
	The writing frequency to the EEPROM exceeds 0.1 million.	
ERR1	The EEPROM of the controller is broken due to high-level electric noise.	If the trouble cannot be solved even after restart, controller need to be replaced.
	Temperature sensor breaks.	If the trouble cannot be solved even after restart, temperature sensor need to be replaced.
	Temperature sensor is short-circuited	If the trouble cannot be solved even after restart, temperature sensor need to be replaced.

Revision history

Rev.A : April.2021

SMC Corporation

4-14-1, Sotokanda, Chiyoda-ku, Tokyo 101-0021 JAPAN
Tel: + 81 3 5207 8249 Fax: +81 3 5298 5362
URL <https://www.smcworld.com>

Note: Specifications are subject to change without prior notice and any obligation on the part of the manufacturer.
© 2021 SMC Corporation All Rights Reserved