

HRL-PF002 Particle Filter Set

Thermo-chiller

Applicable model: HRLE090 Series

Read before using

Thank you for purchasing SMC's Thermo-chiller.
This particle filter set is a set of parts for installing a particle filter into the piping used in the thermo-chiller HRLE series.
Read and understand the instructions shown below before use.

Safety Instructions

- Safety first, only trained personnel who has knowledge of general machinery and equipment can perform the installation of this product.
- Ensure this manual and the Operation Manuals for thermo-chiller are fully understood.
- Disconnect power from the chiller before performing product installation. Be sure to check that the power supply is shut off.
- Remove all circulating fluid before performing product installation.
- Confirm that there is no fluid leakage or condensation after installation.

1. Parts and Accessories

- This particle filter set includes the following parts.
Please confirm that all of them are present before installation.

Parts

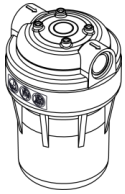

1. Resin filter case

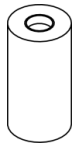

2. Element
(Part No:EJ202S-055X11)
*The element should be replaced when the pressure drop reaches 0.15 MPa.

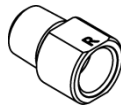

3. RxRc adapter x2pc.

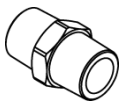

4. Hex nipple x2pc.



5. Sealant tape



6. Operation manual
(This manual)

[Materials of wetted parts]
Stainless Steel, Polycarbonate, PTFE, PP, NBR

2. Mounting

- 1) Select the adapter fitting(Part No.3 or 4) based on the piping to be installed by the customer.
- 2) Confirm that no foreign matter such as dust or dirt is adhered to the connecting ports or the piping where this filter will be fitted.
- 3) Apply the sealant tape (5) to the fittings, and mount them onto the inlet of the resin filter case (1).

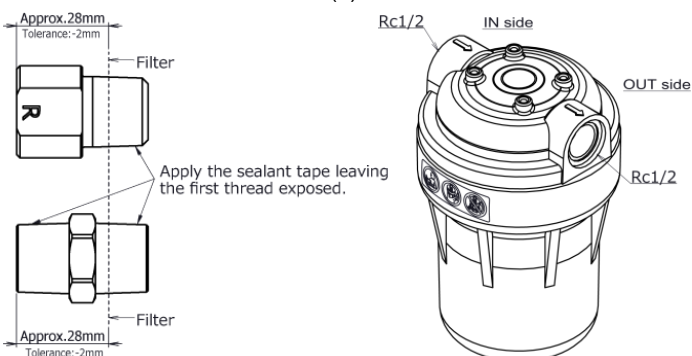

Caution

• It must not be screwed in too much as it can lead to breakage of the filter's ports and/or leakage.

- 4) Insert the element (2) into the resin filter case (1). Mount the resin filter case by hand tighten.



Caution

- Mounting of the case should be hand-tightened. When the case is tightened excessively by tools or handle, the case might crack or be damaged.
- Make sure that the case is held by hand and removed manually when mounting the case. If the case is dropped, it may result in cracking or breakage.

- 5) Insert the element (2) into the case.

As shown in the figure, insert the element into the case so that the element fits into the protrusion of the case. Make sure that the gasket is mounted onto the case correctly. Please note that the gasket can be removed easily. Keep the element vertical in the case, and tighten the case into the cap with the handle (ordered separately). Make sure that the element fits into the protrusion of the cap.

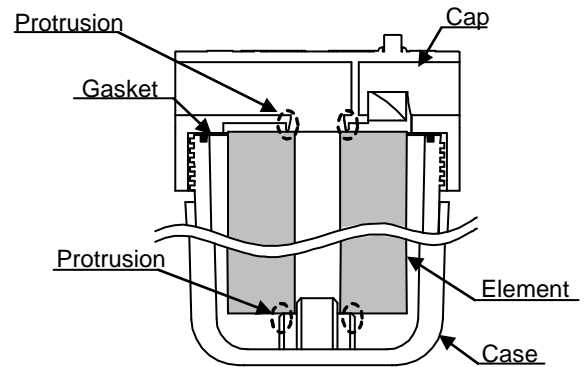

Cross section of the mounting

- 6) After connecting the piping from the filter to the user's site, operate the thermo-chiller to check that liquid does not leak. Please adjust the flow rate so that the initial pressure drop is 0.05MPa or lower. (Approx.100L/min)
- 7) If air remains in the case, press air release button to discharge the air as necessary.

- * When using the filter, the supply pressure should be 0.5MPa (72.5psi) or lower.
- * Please replace the element when the pressure drop of this product reaches 0.15MPa. For replacement of the element, confirm the pressure inside the filter is zero, and refer to mounting procedure 3) and 4).
- * Please order HRR-S0079 separately for the special tool that removes the case.

Revision

Rev. A: July 2022

SMC Corporation

4-14-1, Sotokanda, Chiyoda-ku, Tokyo 101-0021 JAPAN
Tel: + 81 3 5207 8249 Fax: +81 3 5298 5362
URL <https://www.smworld.com>

Note: Specifications are subject to change without prior notice and any obligation on the part of the manufacturer.
© 2022 SMC Corporation All Rights Reserved