



Operation Manual

PRODUCT NAME

Refrigerated Air Dryer

MODEL

IDF370D-3

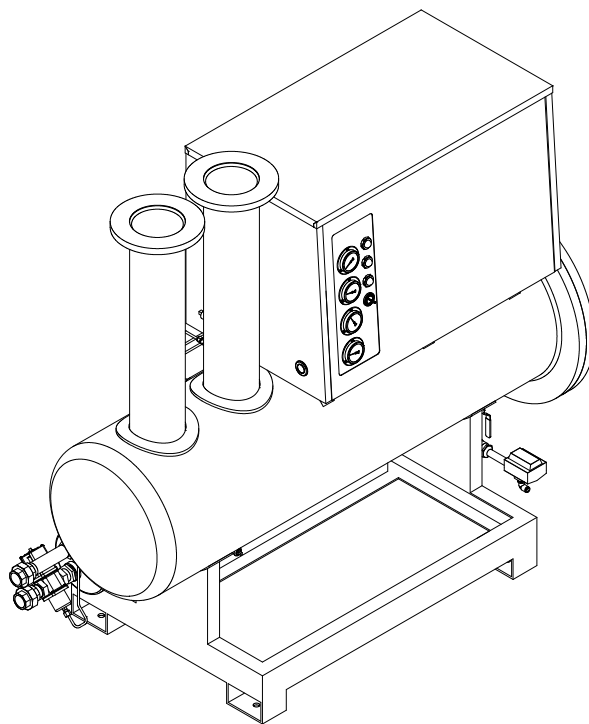

This manual is intended to explain the installation and operation of the product. Only people who understand the basic operation of the product, or have basic knowledge and ability to handle industrial machinery, are allowed to work on the product.

Keep this manual available whenever necessary.

© 2012 SMC CORPORATION All Rights Reserved.

SMC Corporation

Foreword

Thank you for purchasing SMC's refrigerant type air dryer (hereinafter referred to as the "product").

For safety and long life of the product, be sure to read this Operation Manual (hereinafter referred to as the "manual") and clearly understand the contents.

- The instructions described in this manual must be followed in addition to ISO 4414*1) and JIS B 8370*2) and other safety regulations.
 - *1) ISO4414: Pneumatic fluid power – Recommendations for the application of equipment to transmission and control systems.
 - *2) JIS B 8370: General rules for pneumatic equipment.
- This manual is intended to explain the installation and operation of the product. Only people who understand the basic operation of the product through this manual, or who install and operate industrial machinery and have basic knowledge and ability to handle such equipment, are allowed to work on the product.
- This manual and other documents attached to the product do not constitute a contract, and will not affect any existing agreements or commitments.
- It is strictly prohibited to copy this manual entirely or partially for use by a third party without prior permission from SMC.

Note: This manual is subject to change without prior notice.

Table of Contents

Foreword

Chapter i Safety Instructions

i . 1	Warning: Before using this product	i - 1
i . 1. 1	Danger, Warning and Caution.....	i - 1
i . 2	Hazard classification and locations of hazard labels	i - 2
i . 2. 1	Hazards.....	i - 3
i . 2. 2	Warning related to electricity.....	i - 3
i . 2. 3	Warning related to high temperature	i - 3
i . 2. 4	Warning related to pneumatic circuit	i - 3
i . 2. 5	Location of hazard label.....	i - 4
i . 2. 6	Caution related to refrigerant	i - 4
i . 2. 7	Caution related to handling.....	i - 5
i . 2. 8	Other labels.....	i - 6
i . 3	Waste disposal	i - 6
i . 4	Limited warranty and Disclaimer / Compliance Requirements	i - 7

Chapter 1 Name and Function of Parts

1 . 1	Name and function of parts	1 - 1
--------------	---	-------

Chapter 2 Transportation and installation

2 . 1	Transportation	2 - 1
2 . 2	Installation	2 - 2
2. 2. 1	Environment.....	2 - 2
2. 2. 2	Fixing of product	2 - 3
2. 2. 3	Pneumatic piping	2 - 4
2. 2. 4	Draining piping	2 - 4
2. 2. 5	Electric wiring.....	2 - 5
2 . 3	Reinstallation of the product	2 - 7

Chapter 3 Start and stop

3 . 1	Before starting	3 - 1
3 . 2	Start	3 - 1
3 . 3	Stop	3 - 2
3 . 4	Precautions for restarting operation	3 - 2
3 . 5	Check items after starting	3 - 2
3 . 6	Signal output	3 - 2

Chapter 4 Checks and inspection

4 . 1	Daily check	4 - 1
4 . 2	Parts requiring regular maintenance	4 - 1
4. 2. 1	Maintenance of the water-cooled condenser.....	4 - 1
4. 2. 2	Caution for handling the Motor type auto drain	4 - 6

Chapter 5 Troubleshooting

5 . 1	Troubleshooting	5 - 1
5 . 2	Reset of protective equipment	5 - 3

Chapter 6 References

6 . 1	Specification table	6 - 1
6 . 2	Outer dimensions	6 - 2
6 . 3	Electric wiring diagram	6 - 3
6 . 4	Pneumatic and refrigerant circuits and their functions	6 - 4



Safety Instructions



Before using the product be sure to read and understand all the important actions highlighted in this manual.

i.1 Warning: Before using this product

This chapter is intended to specifically describe the safety related issues for handling the product. Read this before handling the product.

- The product is designed to dehumidify compressed air. SMC does not take any responsibility for any problems that may arise from using the product for other purposes.
- The product is operated at high voltage and contains components which become hot and rotate. If a component needs to be replaced or repaired, contact a specialized vendor for parts and service. All personnel who work with or around the product should read and understand the safety related information in this manual carefully before starting work.
- This manual is not a comprehensive manual covering safety and health related issues. This should be handled by a person in charge of safety training.
- All personnel who work with or around the product should have sufficient knowledge about the dangers inherent to the product and be trained in safety measures.
- The safety manager is responsible for strictly observing safety standards, but responsibility in respect to safety standards during daily work resides with each individual operator and maintenance personnel.
- The operator and maintenance personnel should consider work places and environments for each task with due consideration of safety issues.
- It is necessary to undergo appropriate general safety training before being trained about this product. Training without having sufficient knowledge about safety is very dangerous. Training must not be conducted without consideration to safety.
- This manual must be kept available to the operator whenever necessary.
- If the product is subjected to a short power outage (including voltage sag), it may take a long time to start operating normally or be unable to restart normally due to the protective equipment triggered after the power is recovered. In that case, turn off the switch with lamp on the body once, and reset the protective equipment circuit referring to "5.2 Reset of protective equipment". Sudden restart of the product is possible after the recovery of power, so be sure to turn off the Start / Stop switch when removing the cover panel of the product.

i.1.1 Danger, Warning and Caution

The instructions given in this manual aim to assure the safe and correct operation of the product, and to prevent injury of operators or damage to the product. These instructions are grouped into three categories, "Danger", "Warning" and "Caution", which indicate the level of hazard, damage and also the degree of emergency. All safety critical information should be carefully observed at all times.

DANGER, WARNING and CAUTION signs are in order according to severity (DANGER> WARNING> CAUTION). The signs are explained on the following page.

 Danger
<p>"Danger" indicates a hazard with a high level of risk which will result in death or serious injury if an operator performs incorrect handling during the operation and maintenance of the product or does not follow the instructions necessary to avoid it.</p>



Warning

“Warning” indicates a hazard with a medium level of risk which will result in death or serious injury if an operator does not follow the specified procedures during the operation or maintenance of the product or does not follow the instructions necessary to avoid it.



Caution

“Caution” indicates a hazard of a low level of risk which will result in minor and moderate injury or damage to product and equipment if an operator does not follow the specified procedures during the operation and maintenance of the product or does not follow the instructions to avoid it.

i.2 Hazard classification and locations of hazard labels

The product has various potential hazards and they are marked with warning labels. Read this section before starting any work on the product.



Warning

- Only trained personnel should handle the product.
- Only people who have sufficient knowledge and experience about the product and its accessories are allowed to carry out transportation, installation and maintenance work.
- Only maintenance personnel or people who have sufficient knowledge and experience are allowed to open the cover panels of the product.



Warning

If any error occurs, take measures as instructed in this manual.



Warning

- If any error occurs, do not start operating the product.
- If any error occurs, immediately stop the product, and call for the maintenance personnel or a person who has sufficient knowledge and experience about the product and its accessories.

i.2.1 Hazards

The hazards inherent to the product are as follows.

Warning related to electricity

The product is operated at a high voltage and can cause electrical shock internally. This risk is indicated with the mark  in addition to “Danger”, “Warning” and “Caution” on the product or in this manual.

Warning related to heat

The product has surfaces that can reach high temperatures during operation, which may cause burns. This risk is indicated with the mark  in addition to “Danger”, “Warning” and “Caution” on the product or in this manual.

i.2.2 Warning related to electricity



The product is operated at a high voltage and contains the power supply isolated by the cover panel. Do not operate the product without cover panels fitted. Only people who have sufficient knowledge and experience are allowed to perform work and inspections in locations with the power supplied.



Warning

- Fully read and understand the contents of the hazard labels.
- Do not peel or rub off the hazard labels.
- Carefully confirm where the hazard labels are affixed.

i.2.3 Warning related to high temperature



Warning

The product has surfaces that can reach high temperatures during operation, and cause burns by contact. Even after the power is turned off, there can still be residual heat in the product, which may cause burns. Do not start work until the temperature of the surfaces has fallen below 50°C.

i.2.4 Warning related to pneumatic circuit



Warning

Be sure to release compressed air from the product and ensure the internal pressure is zero before replacing or cleaning the parts of the product. If the compressed air is left in the product, when some part is loosened, it may cause sudden lurching or other unexpected accidents.

i.2.5 Location of hazard label

Warning
<ul style="list-style-type: none"> - Fully read and understand the contents of the hazard labels. - Do not peel or rub off the hazard labels. - Carefully confirm where the hazard labels are affixed.

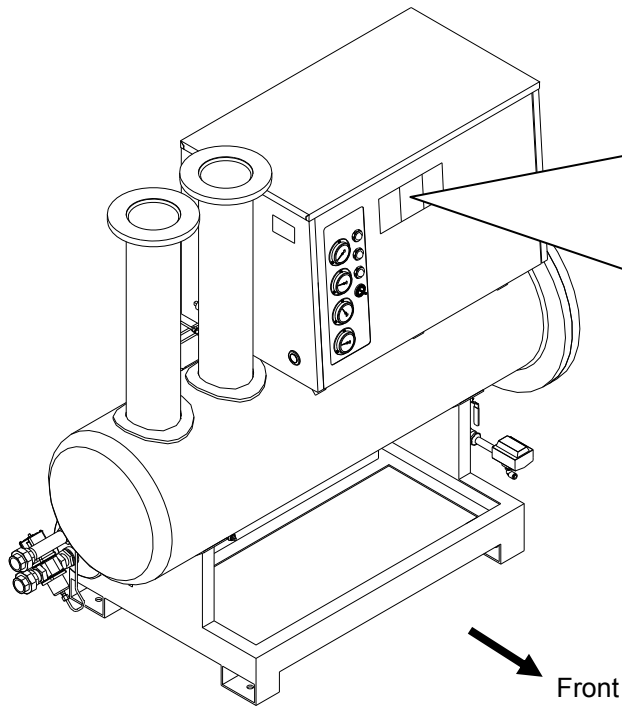

WARNING 警告
<ol style="list-style-type: none"> 1 Remove panels for maintenance only. 2 Never insert anything into product to ensure safety. 3 Cut power prior to maintenance to prevent electric shock. 4 Settle product to room temp. before maintenance to prevent burn or frostbite. 5 Ensure zero air pressure before replacing parts.
<ol style="list-style-type: none"> 1 点検以外はパネルを取り外さないこと。 2 回転物があるので指、棒状の物を差し込まないこと。 3 感電の恐れがあるので、点検の前には電源を切ること。 4 火傷の恐れがあるので、点検の前には装置を常温にすること。 5 部品交換の前には必ず、空気圧力を“0”にすること。

i.2.6 Caution related to refrigerant

Caution
<ul style="list-style-type: none"> - The product uses hydro-fluorocarbon type refrigerant (HFC). - The product is categorized as category 1 under the fluorocarbon recovery and destruction law in Japan. <p>The release of refrigerant into the atmosphere is banned by law. When the product is serviced, the refrigerant must be recovered using “refrigerant recovery equipment” and disposed of by a specialist disposal company. Only people who have sufficient knowledge and experience about the product and its accessories are allowed to recover the refrigerant.</p> <ul style="list-style-type: none"> - Only maintenance personnel or people who have sufficient knowledge and experience are allowed to open the cover panels of the product. - The type and necessary amount of HFC can be found on the specification label explained on page 6 of Section i.

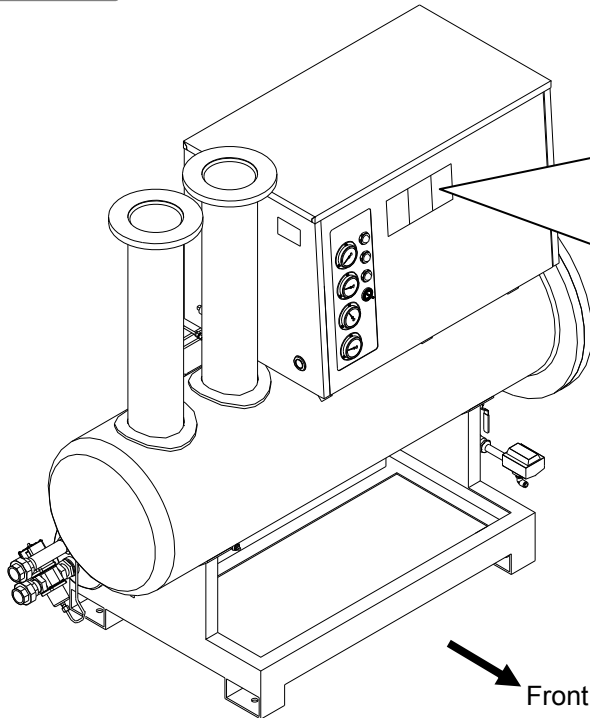

Fluorocarbon Collection and Destruction Law in Japan
フロン回収破壊法第一種特定製品

This product uses
Fluorocarbon (HFC) as a refrigerant.

- 1 It is strictly forbidden to emit Fluorocarbon to the atmosphere.
- 2 When disposing this product, Fluorocarbon must be collected in an appropriate manner.
- 3 The kind of Fluorocarbon and the amount used in this product is printed on the name label.

この製品には冷媒として、
フロン類(HFC)が使われています。

- 1 フロン類をみだりに大気中に放出することは禁じられています。
- 2 この製品を廃棄する場合には、フロン類の回収が必要です。
- 3 フロン類の種類及び数量は、型式銘板に記載されています。

i.2.7 Caution related to handling



Warning

- Fully read and understand the contents of the hazard labels.
- Do not peel or rub off the hazard labels.
- Carefully confirm where the hazard labels are affixed.

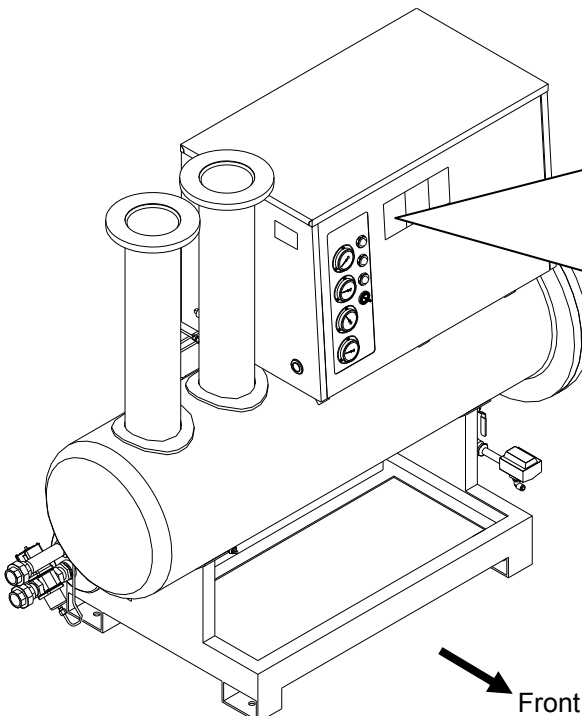

CAUTION 注意

- 1 Read manual before operation.
- 2 Ensure ventilation and maintenance space.
- 3 Keep water away from the product.
- 4 Secure In / Out connector with spanner during piping.
- 5 Wait 3 minutes before restart.
- 6 Ensure Running Condition / Evaporating Temp. in green zone.

- 1 ご使用前に必ず取扱説明書を読んでください。
- 2 通風、メンテナンススペースを確保してください。
- 3 雨や水滴がかからないようにしてください。
- 4 IN/OUTポートをスパナで固定して配管してください。
- 5 再起動は運転停止3分後に行ってください。
- 6 RUNNING CONDITION・蒸発温度計はグリーン帯で使用してください。

i.2.8 Other labels

Confirm the model and specifications described in the label.

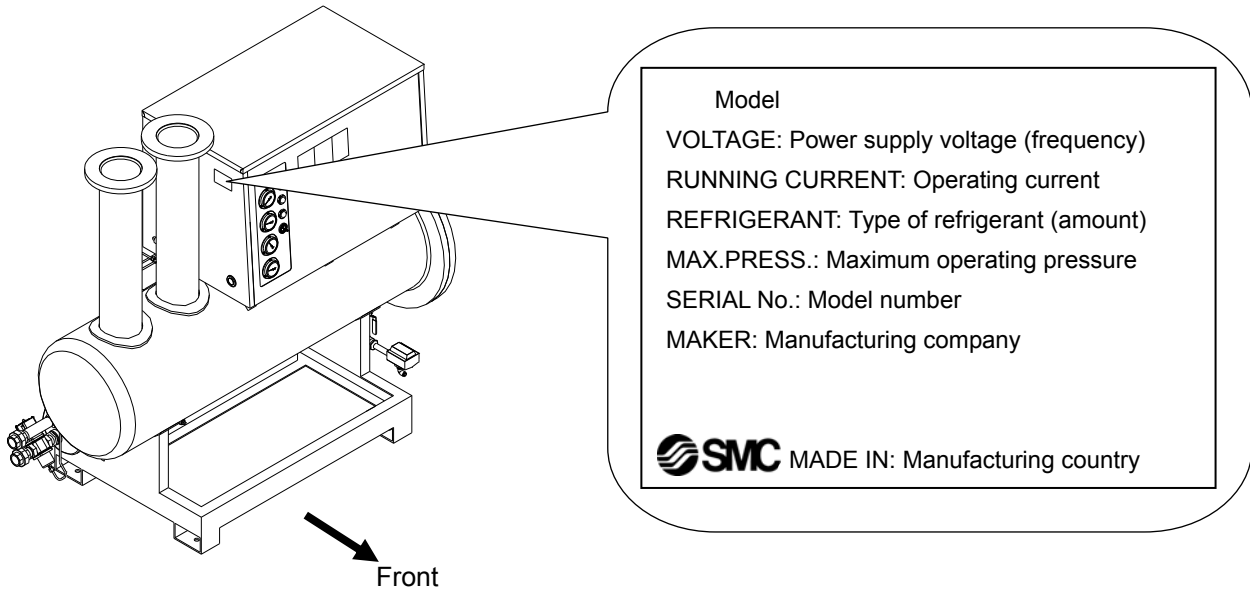

i.3 Waste disposal

When disposing of the product, recover the refrigerant and compressor oil contained in the refrigerant circuit.

 Caution
<ul style="list-style-type: none"> - The product uses hydro-fluorocarbon type refrigerant (HFC). - The product is categorized as category 1 under the fluorocarbon recovery and destruction law in Japan. - The release of refrigerant into the atmosphere is banned by law. When the product is serviced, the refrigerant must be recovered using “refrigerant recovery equipment” and disposed of by a specialist disposal company. - Only people who have sufficient knowledge and experience about the product and its accessories are allowed to recover the refrigerant. - Only maintenance personnel or people who have sufficient knowledge and experience are allowed to open the cover panels of the product. - The type and necessary amount of HFC can be found on the specification label.

 Caution
<ul style="list-style-type: none"> - The disposal of the compressor oil must be in compliance with the bylaws or rules of the local municipality. - Do not mix the compressor oil with domestic waste for disposal. Also, the disposal of the waste must only be conducted by specific facilities that are permitted for that purpose. - Only people who have sufficient knowledge and experience about the product and its accessories are allowed to recover the compressor oil. - Only maintenance personnel or people who have sufficient knowledge and experience are allowed to open the cover panels of the product. If anything is unclear, contact your local supplier or SMC.

i.4 Limited warranty and Disclaimer / Compliance Requirements

The product used subject to the following “Limited warranty and Disclaimer” and “Compliance Requirements. Read and accept them before using the product.

Limited warranty and Disclaimer

1. The warranty period of the product is 1 year in service or 1.5 years after the product is delivered. Also, the product may have specified durability, running distance or replacement parts. Please consult your nearest sales branch.
2. For any failure or damage reported within the warranty period which is clearly our responsibility, a replacement product or necessary parts will be provided. This limited warranty applies only to our product independently, and not to any other damage incurred due to the failure of the product.
3. Prior to using SMC products, please read and understand the warranty terms and disclaimers noted in the specified catalog for the particular products.

Compliance Requirements

1. The use of SMC products with production equipment for the manufacture of weapons of mass destruction (WMD) or other weapon is strictly prohibited.
2. The exports of SMC products or technology from one country to another are governed by the relevant security laws and regulation of the countries involved in the transaction. Prior to the shipment of a SMC product of a SMC product to another country, assure that all local rules governing that export are known and followed.

Caution

The Product is provided use in manufacturing industries.

The product herein described is basically provided for peaceful use in manufacturing industries.

If considering using the product in other industries, consult SMC beforehand and exchange specifications or a contact if necessary.

If anything is unclear, contact your nearest sales branch.

1 Name and Function of Parts

1.1 Name and function of parts

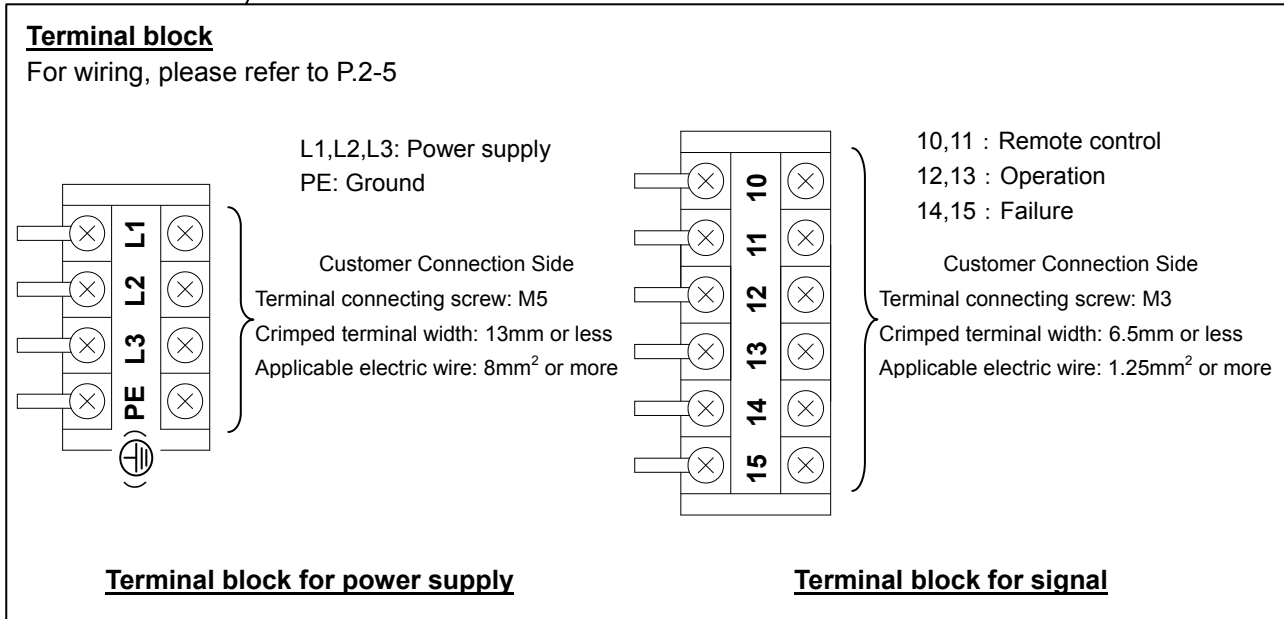
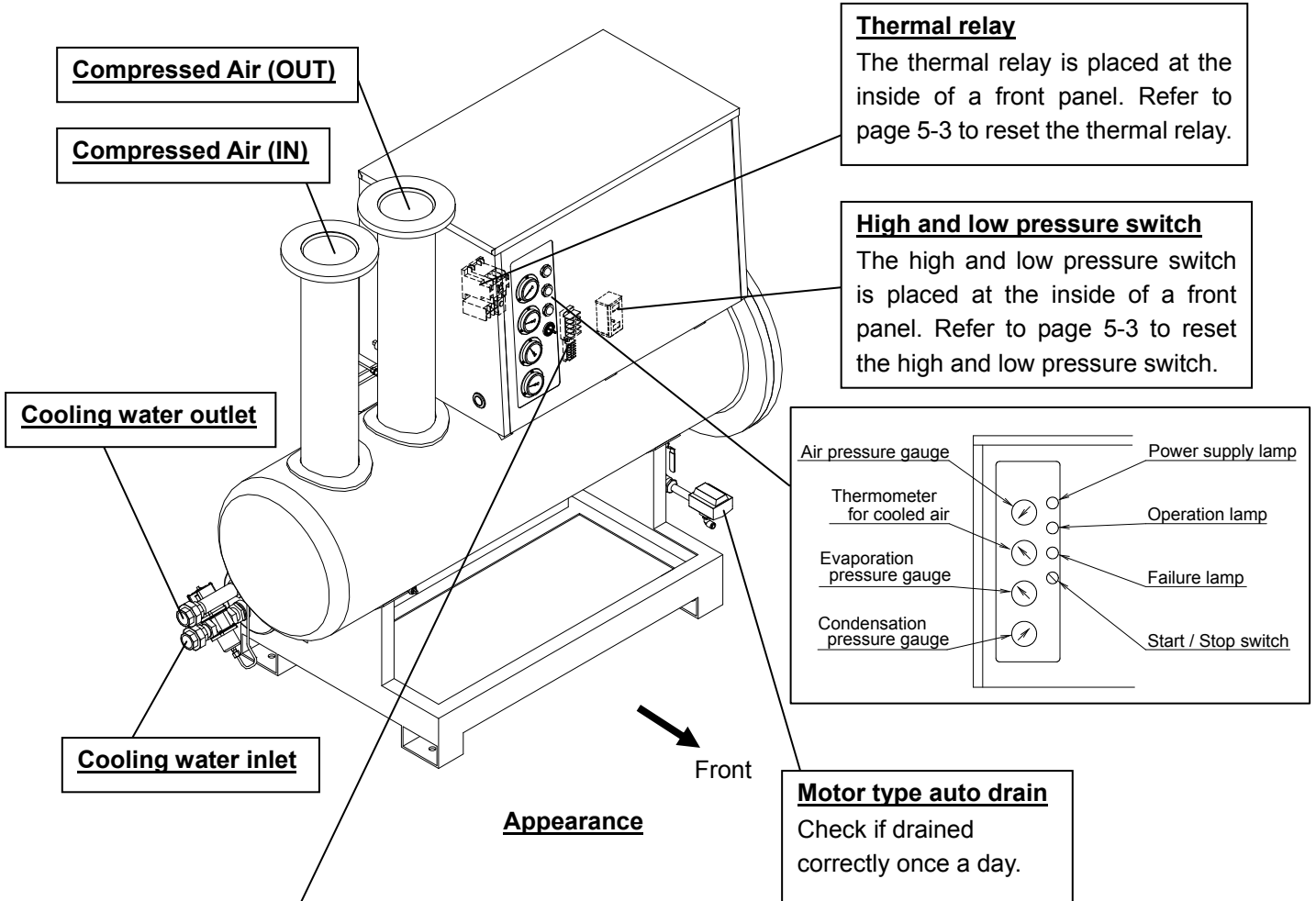

2**Transportation and installation** **Warning**

- Use the product in an appropriate manner, and pay attention to safety, particularly physical safety of operators, during the installation, operation, maintenance and checks of the product.
- When the product is used for a critical facility or equipment, prepare a spare product or alternative machine in case of stoppage of the product due to the operation of the protective equipment or the failure of the product itself.

 **Caution**

- Only people who have sufficient knowledge and experience about the product and system are allowed to perform the transportation, installation and maintenance of the product, including dangerous work.

2.1 Transportation

Be sure to follow the instructions below when transporting the product.

- The product is filled with refrigerant. Transport it (by land, sea or air) in accordance with laws and regulations specified.
- When carrying the product, be careful not to let it drop or fall over. Should uplift the product from the base surface.
- Never lay the product down for transportation. It may lead to damage to the product.
- Do not hang up the product.

 **Warning**

- The product is heavy and has potential dangers in transportation. Be sure to follow the instructions above.
- To transport the product, be sure to use a fork lift.

2.2 Installation

2.2.1 Environment

- (1) Do not use or store the product under the following conditions, as these may cause breakage of the product as well as a failure of the product to operate.
- In an environment where the product will come into direct contact with rain, wind and snow or with a lot of moisture (relative humidity 85% or more).
 - In a location with a large quantity of dust.
 - In a location containing flammable or explosive gases.
 - In a location exposed to corrosive or flammable gases or solvent.
 - In a location where the ambient temperature is outside the following ranges.
In operation: 2 to 43°C, In storage: 0 to 50°C (with no condensate in piping)
 - In a location that is subjected to abrupt changes in temperature.
 - In a location that is subjected to strong electromagnetic noise (intense electric field, intense magnetic field, or surges)
 - In a location that is subjected to static electricity, or conditions where static electricity can discharge to the product.
 - In a location that is subjected to strong high frequency radiation (microwaves)
 - In a location that is subjected to potential lightning strikes.
 - In a location with an altitude of 2,000 metres or higher.
 - In a location where the product is affected by strong vibrations or impacts.
 - Conditions where external force or weight is applied that could deform the product.
 - In a location where there are obstacles blocking the ventilation ports of the product.
 - In a location where the dryer is drawing in high temperature air that is discharged from an air compressor or other dryers.
- (2) Contact SMC beforehand and take special consideration of safety measures if the product is to be used in any of the following conditions.
- Conditions and environments outside of the given specifications, or use outdoors or in a place exposed to direct sunlight.
 - Installation on equipment in conjunction with atomic energy, railways, air navigation, shipping, vehicles, medical treatment or recreation equipment, or equipment in contact with food and beverages, emergency stop circuits, clutch and brake circuits in press applications, safety equipment or other applications unsuitable for the standard specifications described in the product catalog.
 - An application which could have negative effects on people, property, or animals requiring special safety analysis.

2.2.2 Fixing of product

Mount the product on a flat and stable floor with no vibrations.

- Refer to "6.2 Outer dimensions" on page 6-2 for dimensions.

Use the foundation bolts to prevent the product from falling over.

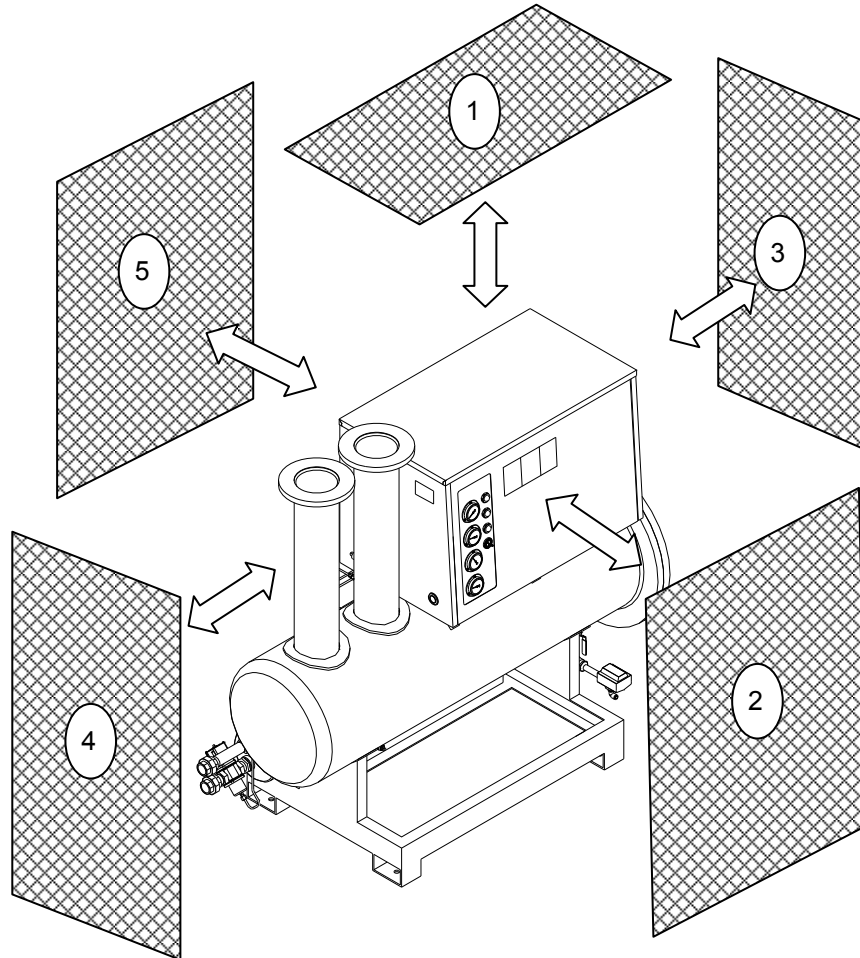

	Necessary maintenance space *1
1. Top	1m or more
2. Front	1m or more
3. Right side	1m or more
4. Left side	1m or more
5. Rear	1m or more

* 1 The necessary installation space is to secure the original performance of the product and conduct daily checks on the product.

2.2.3 Pneumatic piping

- Do not apply the weight of pipes and excessive force during piping to the product.
- Be careful not to transmit vibration resulting from the compressor.
- When the compressed air inlet temperature exceeds 50°C, install an aftercooler behind the air compressor or decrease the temperature of the area where the air compressor is installed to keep it 50°C or less.
- To prevent foreign matter such as dust from getting in the supply air to the product, flush the piping before connecting. Dust or oil in the piping can cause cooling failure or other failures of the product.
- Use a pipe capable of withstanding the specified operating pressure and temperature and connect so that it will not have leakage.
- Be sure to install a bypass pipe to allow maintenance without stopping the air compressor.

2.2.4 Draining piping

- Release the draining end of the tube to atmosphere to let condensate flow into a water outlet.
- Ensure the drain tube does not rise up.
- Condensate will be drained regularly using compressed air pressure. Fix the draining end of the tube firmly to prevent it from vibrating during draining.
- Do not bend or crush the drain tube. When installing the product, take care not to place the product on the drain tube.

 Warning
--

- | |
|---|
| <ul style="list-style-type: none">- When draining, follow the user's own procedure to keep operators safe. (E.g. Wear protective goggles, apron and gloves to prevent contact with the drained condensate.)- When oils can enter the drained condensate, waste water treatment is necessary. <p>Follow the bylaws or rules of the local municipality.</p> |
|---|

2.2.5 Electric wiring

Warning

Only qualified persons are allowed to wire the product.

- Before wiring, be sure to shut off the power supply. Never perform wiring work while the product is energized.
- Ensure a stable power supply with no voltage surges.
- Ensure that an ground fault circuit interrupter with appropriate capacity for ground fault and load is used in the power supply of the product to prevent electrical shock and burnout of the compressor motor. See “6-1 Specification table” for details.
Use a power supply suitable for the specifications of the product.
Be sure to connect the ground connection.
- Grounding should never be connected to a water line, gas line or lightning rod.
- Multiple wiring is dangerous because it may lead to heat generation and cause a fire.
- Do not modify the electrical wiring of the power supply.
- For use in Europe, install a breaker compliant with applicable IEC standards to the power supply of the product.

[Wiring of power supply]

Remove the front panel of the product. Connect the power supply cable through the grommet with membrane. (Three-phase AC200V type)

- * Be sure to install an ground fault circuit interrupter to the power supply. (To be prepared by the user.)
[Sensitivity of leak current: 30mA or less, Rated current: 50A]

Specifications of power supply cable

Prepare the following power supply cable.

Power supply cable: 8mm²(8AWG) or larger, Cable outside diameter Approx. 26mm, 4 cores (including ground)

Approx. 0.3m is necessary to route the internal wiring of the product.

Power supply cable length

The power supply cable length from the product should be less than 30m.

Terminal block (refer to “1.1 Name and function of parts” for details).

Connect the power supply cable and ground to the terminal block on the right. The connection size is M5.

Be sure to use a round crimped terminal.

Applicable crimped terminal width: 13mm or less

[Wiring procedure]

1. Remove the front panel of the product.
2. Introduce the cable through the grommet with membrane to connect to the terminal block.

(Refer to the label on the terminal block.)

M5 tightening torque: 3 to 4.5Nm

Do not touch equipment other than the terminal block during wiring.

3. Put back the front panel.

[Wiring for operation, error signal and remote control]**Specifications of signal cable**

Prepare the following cable.

Cable: 0.5mm² (20AWG), Cable outside diameter: 17mm or less, 6 cores 0.5mm²

Approx. 0.9m is necessary to route the internal wiring of the product.

Signal cable length

The signal cable length from the product should be less than 30m.

Terminal block (refer to "1.1 Name and function of parts" for details).

Connect the signal cable to the terminal block on the left. The connection size is M3.

Applicable crimped terminal width: 6.5mm or less

[Wiring procedure]

1. Remove the front panel of the product.
2. Introduce the cable through the grommet with membrane to connect to the terminal block.

(Refer to the label on the terminal block.)

M3 tightening torque: 0.63 to 1Nm.

Do not touch equipment other than the terminal block during wiring.

3. Put back the front panel.

[Remote control]

* Voltage is applied to the terminal block. Be sure to turn off the Start / Stop switch before wiring.

- 1) Disconnect the wires from no. 5 and 6 of the terminal block and mount the external switch.
 - The external switch used for remote control should be an alternate type (no voltage dry contact).
- 2) For remote control, with the Start / Stop switch turned on, turn the external switch on and then off.
 - In remote control, the product cannot be started up from the operation panel.
 - When the product is to be stopped during remote control, turn off the Start / Stop switch.

2.3 Reinstallation of the product

 **Caution**

- Only people who have sufficient knowledge and experience about the product and its accessories are allowed to reinstall the product in a different location. Also, be sure to follow the instructions below.

When moving the product to a different location or reinstalling it after it has been used (including trial run), follow the whole procedure in Chapter 2 beforehand.

- Disconnection of power supply cable

Be sure to cut the facility power supply before disconnecting the power supply cable.

 **Warning**

- Only people who have sufficient knowledge and experience are allowed to perform wiring.
- Before wiring, be sure to shut off the power supply. Never perform wiring work while the product is energized.

Removal of pneumatic piping

 **Warning**

- Only people who have sufficient knowledge and experience are allowed to perform piping work.
- Before removing piping, be sure to shut off the air supply and the product.
- Do not remove piping with any air pressure remaining internally.

Clean off any sealant debris after the piping is removed. If any sealant debris gets into the product during reinstallation, it may lead to cooling failure or other product failures.

[How to release the compressed air]

1. The bypass valve needs to be opened only if compressed air is necessary while the product is removed.
2. Close the compressed air inlet valve and outlet valves.
3. Check the ball valve of the auto drain is open.
4. Press the manual button to release the compressed air pressure in the product.

For details, refer to the cautions for handling the auto drain with motor in "Chapter 4 4.2 Parts requiring regular maintenance".

3**Start and stop****Caution**

Only people who have sufficient knowledge and experience about the product and its accessories are allowed to start and stop the product.

3.1 Before Starting

Check the following items before performing a trial run of the product.

- Installation conditions

Check visually that the product is installed horizontally.

Ensure the product is fixed firmly by the anchor bolts.

Do not place any heavy object on the product, or apply excessive force to the product by the external piping.

- Connection of cables

Check the power supply and ground are correctly connected.

- Pneumatic piping

Check proper connection of pneumatic piping. Ensure the valves at the inlet and outlet and bypass of the product are completely closed.

- Ball valve

Check the ball valve of the auto drain is open.

3.2 Start

Start the product by the following procedure.

1) Turn on the main power supply breaker. The [Power] lamp will light up.

For remote control, turn on the external switch as well.

2) Turn on Start / Stop switch as well. The [Power] lamp will light up.

3) Slowly open the compressed air IN · OUT side valve. Ensure the bypass valve is completely closed. Check there is no air leakage.

4) The thermometer for cooled air indicates 2 to 15°C. If the thermometer for cooled air indicates a temperature higher than 2 to 15°C, please refer to "Chapter 5 Troubleshooting".

5) A while after the compressed air starts being supplied, the drain tube will drain condensate automatically.

Keep operation in that condition.

**Caution**

- Frequently turning on and off the switch can cause failure.

3.3 Stop

- 1) Turn off the Start / Stop switch.
For remote control, turn off the external switch as well.
- 2) The run lamp will go off and operation will stop.

3.4 Precautions for restarting operation

- Allow at least 5 minutes before restarting the product. If the product is restarted within 5 minutes after being stopped, the protection circuit will be activated, operating light will turn off and the dryer will not be activated.
- If operation cannot be restarted, refer to “Chapter 5 Troubleshooting” to solve it.

3.5 Check items after starting

Check the following items when starting the product. Immediately stop the operation in the event of failure. Turn off the Start / Stop switch and shut off the breaker of the main power supply.

- There is no compressed air leakage.
- The pressure, temperature, flow rate and ambient temperature of the compressed air are within the specified range.
- Condensate is coming out from the drain tube.
- The thermometer for cooled air indicates 2 to 15°C.
- There is no abnormal sound, vibration or odor from the product.

3.6 Signal output

- The operation signal and failure signal are output with dry contact.

	Signal output
1. Operation signal	- At start: Closed - At stop: Open (Including Failure): Open
2. Failure signal	- Protective equipment in operation: Closed - Protective equipment not in operation: Open

* If the product is stopped by the overload relay built into the compressor, the Failure signal will not be output.

- Contact capacity
AC200V,5A DC24V,5A for both operation and failure stop signal.
20V, 5mA (AC/DC)

4

Checks and inspection

4.1 Daily check

Check the following items daily. Immediately stop the operation in the event of failure, and refer to “Chapter 5 Troubleshooting” to solve it.

- There is no compressed air leakage.
- The START lamp lights up during operation.
- Condensate comes out of the drain tube during operation.
- The thermometer for cooled air indicates 2 to 15°C during operation with the compressed air supplied.
- The condensing pressure gauge and the evaporation pressure gauge indicate 1 of the table below during operation stops with no compressed air applied.
- There is no abnormal sound or vibration.
- There is no abnormal odor or smoke.

Table 1

Cooling water temperature	Approx. 10°C	Approx. 20°C	Approx. 30°C
Condensation pressure	0.6MPa or more	0.7MPa or more	0.95MPa or more
Evaporation pressure			

4.2 Parts requiring regular maintenance

4.2.1 Maintenance of the water-cooled condenser

If a water-cooled air dryer is used temporarily, dirt will accumulate on the cooling water side of the water-cooled condenser.

Then, the condensation capacity will decrease and the condensation pressure will become extremely high, causing the protective equipment of the air dryer to operate. If the air dryer is operated, read the cautions below carefully and conduct maintenance of the condenser.

(1) Cooling water

In general, ground water or tap water/ industrial water is assumed to be used as cooling water for the water-cooled condenser. Also, the methods are divided into two categories, transient type and circulating type.

In the transient method, the ground water or tap water/ industrial water is continuously supplied to the water-cooled condenser, and the water whose temperature has risen is discharged outside. This method is used in locations where there is a plentiful supply of water.

In the circulating method, heat is absorbed by the water-cooled condenser, and the water whose temperature has risen is cooled down using a cooling tower or a chiller to recycle it.

A decrease in performance of the water-cooled condenser is mostly attributed to corrosion of the facility water or adhesion of scale etc.

(2) Cooling water quality standard

- Water quality standard

If water is used as the cooling water, please refer to JRA-GL-02-1994 [water quality guidelines for refrigeration and air-conditioning equipment] prepared by Japan Refrigeration and Air Conditioning Industry

Association as a reference for the water quality level to prevent excessive corrosion and scale-related problems. The values are shown in Table 2 on this page.

Table 2

Item		Facility water system		
		Circulating type		Transient type
		Circulating fluid	Filling of circulating fluid	Transient fluid
Standard items	pH [25°C]	6.5 to 8.2	6.0 to 8.0	6.8 to 8.0
	Electrical conductivity (mS/m) [25°C]	80 or less	30 or less	40 or less
	Chloride ions (mg/L)	200 or less	50 or less	50 or less
	Sulfuric acid ions (mg/L)	200 or less	50 or less	50 or less
	Acid consumption [pH4.8](mgCaCO ₃ /L)	100 or less	50 or less	50 or less
	Total hardness (mgCaCO ₃ /L)	200 or less	70 or less	70 or less
	Calcium hardness (mgCaCO ₃ /L)	150 or less	50 or less	50 or less
	Ionic state silica (mgSiO ₂ /L)	50 or less	30 or less	30 or less
Reference items	Iron (mg/L)	1.0 or less	0.3 or less	1.0 or less
	Copper (mg/L)	0.3 or less	0.1 or less	1.0 or less
	Sulfide ions (mg/L)	Shall not be detected.	Shall not be detected.	Shall not be detected.
	Ammonium ions (mg/L)	1.0 or less	0.1 or less	1.0 or less
	Residual chloride (mg/L)	0.3 or less	0.3 or less	0.3 or less
	Free carbon dioxide (mg/L)	4.0 or less	4.0 or less	4.0 or less
	Stability index	6.0 to 7.0 or less	—	—

- Water quality inspection (Once a month)

If tap water or ground water (well water) is used as the cooling water for the water-cooled condenser, test the items shown in Table 2 using JIS K 0101 (Test methods for industrial water) or methods based on these methods, and determine the applicability of the water based on the criteria shown in Table 2.

If the values are outside of the criteria, the following measures shall be taken before using it.

- a) Change of the water source (e.g. Change ground water to tap water.)
- b) Consult a water treatment consultant about how to treat the water.
- c) Change the cooling method from transient type to circulating type, and use applicable facility water.

If the cooling water in a cooling tower is used, the water quality standard will be satisfied at the initial stage, however, if it is used in an air contaminated environment, sulfurous acid gas in the air may dissolve into the cooling water, forming sulfuric acid which may corrode the electro-thermal surface. Therefore, control the water quality regularly by inspecting and replacing the cooling water regularly.

Fig.1 shows due to poor water quality and preventive measures the next page.

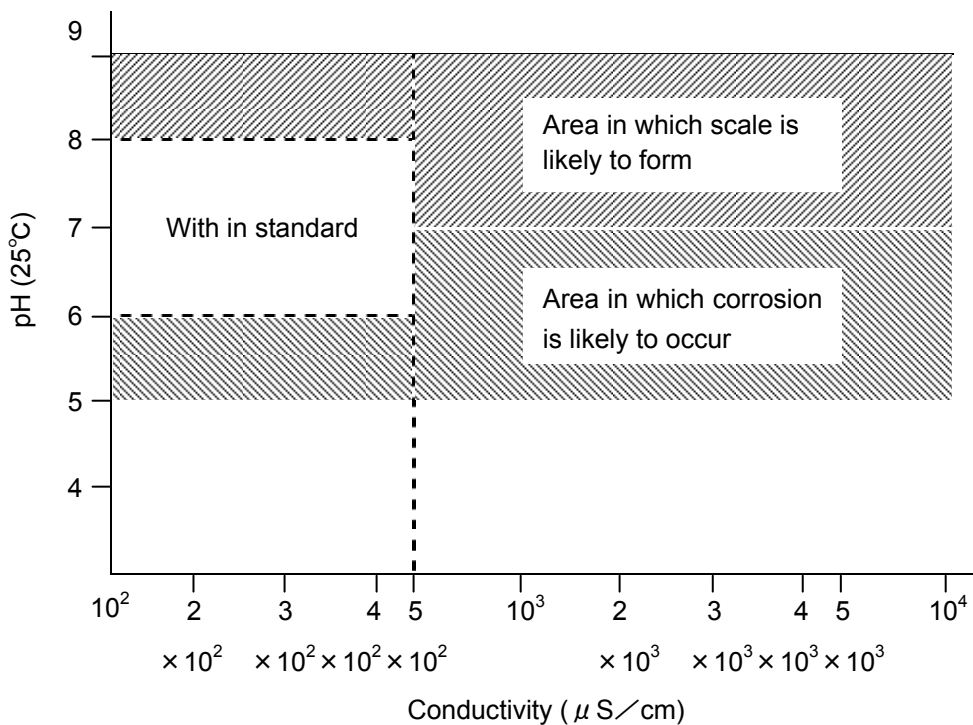

Fig. 1 Relationship between pH and conductivity

(3) Method of washing cooling water side of water-cooled condenser

Despite carrying out adequate control of cooling water quality, scale will form on the walls of the cooling pipes, causing performance to be reduced. Accordingly, periodically clean the inside of the cooling pipes as outlined below.

- Chemical cleaning method

Chemical cleaning is divided into two methods, static method and circulating method. The latter is more effective. When performing chemical cleaning, beware of hazardous gases being generated and corrosion by the cleaning liquid.

a) Operation procedure of the circulating method

1. Connect the cleaning circulation pump (if necessary, use an acid resistant pump) to the cooling water inlet and outlet of the tank heat exchanger with a hose.
2. Start the dryer. At this time, do not supply the compressed air.
3. Supply the cleaning liquid to the tank, and circulate it for a certain amount of time.
4. Discharge the cleaning liquid, and wash through with water to completely remove the cleaning liquid.
5. Stop this equipment.

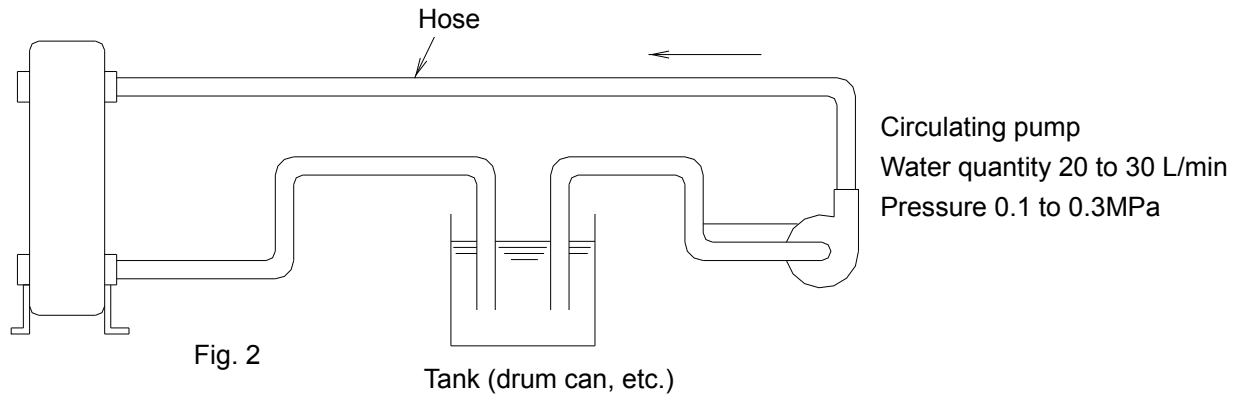

b) Operation procedure when a cooling tower is used

1. If a cooling tower is used, supply the cleaning liquid and circulate it for a certain amount of time.
2. Exhaust the cleaning liquid, and wash through with water to completely remove the liquid.

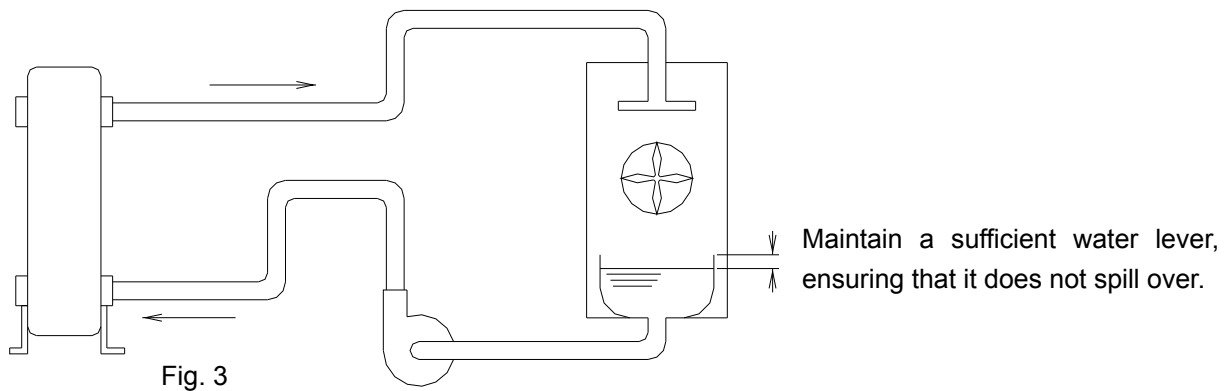

Caution

- 1) Follow the user's own procedure to keep operators safe. (E.g. Wear protective goggles, apron and gloves to prevent contact with the drained condensate.)
- 2) When the circulating method is selected, check leakage and pump pressure carefully before cleaning to prevent leakage of the cleaning liquid.
- 3) When chemical cleaning is performed, the amount, time and treatment vary depending on the type of cleaning liquid. Therefore, follow the operation manual of each type of cleaning liquid when cleaning. Pay careful attention to the drainage.
- 4) Confirm the cleaning effect by the following methods.
 - How much scale comes off.
 - Confirm change (reduction) in the pressure drop of the facility water system with discharge pressure of the pump.

- Mechanical cleaning method

There are two mechanical cleaning methods: One is to use a brush, and the other is to use the tube cleaner.

a) Cleaning using brush

1. Example of brush dimensions and material

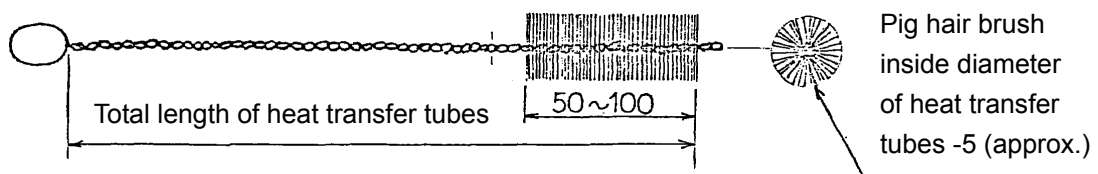

Fig. 4 Brush

2. Cleaning method

Insert the brush into the piping of the water-cooled condenser. Move the brush back and forth to clean it. Before inserting the brush, wet the inside of the tubes.

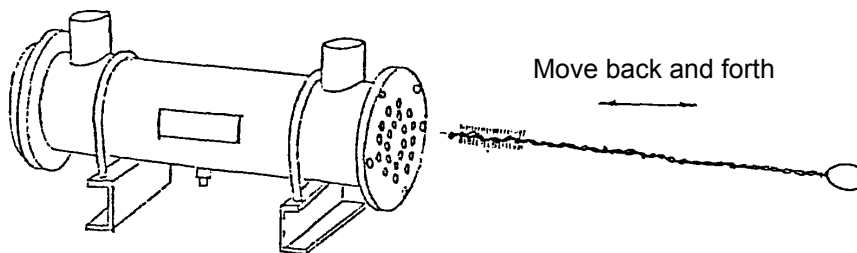

Fig. 5 Outline of cleaning method

⚠ Caution

Scale and slime which adheres to the inside of the heat transfer tubes will gradually become hard. It is therefore necessary to clean it off with a brush before this happens. The interval for cleaning is roughly once a month.(Depending on water quality)

b) Operation procedure with tools

Clean the inside of the water-cooled condenser piping with a tube cleaner. (Figure 6) It is effective to clean the piping by flushing with water.

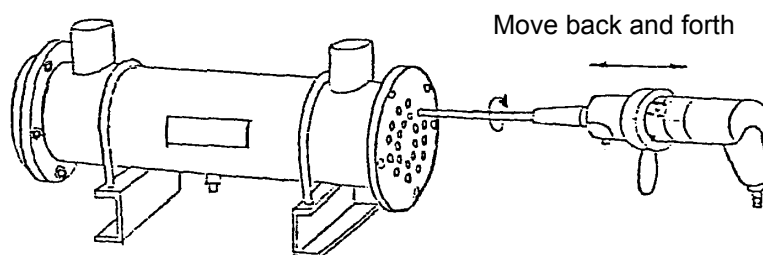



Fig. 6 Example of use of tube cleaner

 Caution
<p>If the end of the tube cleaner is inserted into the U shaped part of the piping, the internal surface of the piping may be damaged. Take care not to damage the internal surface of the piping during cleaning.</p>

4.2.2 Caution for handling the Motor type auto drain

Check the auto drain condition at least once a day. Press the manual button to flush the discharge valve. When the drain is not discharged properly even after flushing the discharge valve, replace the auto drain or repair it.

- Motor type auto drain

Model	description	quantity
ADM200-042-8	Motor type auto drain	1

 Danger
<ul style="list-style-type: none"> - Do not remove the motor type auto drain with any air pressure remaining internally. If the compressed air is left in the product, when some part is loosened, it may cause sudden lurching or other unexpected accidents. - When removing the panel, wear protective gloves to prevent injuries.

 Danger
<p>Do not remove the motor type auto drain while operating the product. There are parts that get hot and the power supply is at a high voltage during operation. Burns by heat and electrical shock by high voltage can result.</p>

 Danger
<p>There is a risk of touching drained waste liquid during replacement. When draining, follow the user's own procedure to keep operators safe. (E.g. Wear protective goggles, apron and gloves to prevent contact with the drained condensate.)</p>

 Warning
<p>When oils can enter the drained condensate, waste water treatment is necessary. Follow the bylaws or rules of the local municipality for disposal.</p>

5

Troubleshooting

5.1 Troubleshooting

If any error is found in the product, investigate the following points. If the error cannot be solved, turn off the power supply and contact your local supplier or SMC sales representative.

Trouble	Possible cause	Remedy
Although the switch with lamp is turned on, the run lamp does not light up and the product does not start operating.	The power supply cable has been loosened or disconnected.	- Reconnect it firmly.
	The ground fault circuit interrupter is not turned on	Check the capacity of the ground fault circuit interrupter. - Check the product was not restarted within 5 minutes after being stopped. - Turn on the ground fault circuit interrupter and try to operate. If the ground fault circuit interrupter turns back off, the insulation failure of the product is suspected. Turn off the power supply and contact SMC.
	The Three-phase power supply is connected incorrectly.	- Swap over the connection of 2 of the 3 wires (R and T phases).
The lamp goes off and the compressor for refrigeration stops.	Water-cooled condenser is dirty.	- Clean the cooling water side once a month.
	The cooling water temperature is high.	- Reduce the cooling water temperature as much as possible.(Reconsider the cooling tower.)
	The compressed air temperature is too high.	- Improve the ventilation in the location where the air compressor is installed, or decrease the ambient temperature to allow the discharge air temperature of the air compressor to go down. - Install an aftercooler after the air compressor to reduce the temperature. - Refer to "5.2 Reset of protective equipment" and reset the protective circuit.
	The fluctuation of the power supply voltage is too large.	- Install a power supply transformer or use a different power supply to provide appropriate voltage. - The fluctuation of the power supply voltage should be kept within +/-10% of the rated voltage. - Refer to "5.2 Reset of protective equipment" and reset the protective circuit.
When the cooling water is not flowing, the compressor for refrigeration has stopped with the lamp lit up.	Water-cooled condenser is dirty.	- Clean the cooling water side once a month.
	The cooling water temperature is high.	- Reduce the cooling water temperature as much as possible.(Reconsider the cooling tower.)
	The built-in overload relay of the compressor for refrigeration has started.	- Check the product was not restarted within 3 minutes after being stopped.

Trouble	Possible cause	Remedy
The thermometer for cooled air is higher than 15°C while the cooling water is circulating.	Water-cooled condenser is dirty.	- Clean the cooling water side once a month.
	The facility water temperature is high.	- Reduce the cooling water temperature as much as possible.(Reconsider the cooling tower.)
	The compressed air temperature is too high.	<ul style="list-style-type: none"> - Improve the ventilation in the location where the air compressor is installed, or decrease the ambient temperature to allow the discharge air temperature of the air compressor to go down. - Install an aftercooler after the air compressor to reduce the temperature. - Refer to "5.2 Reset of protective equipment" and reset the protective circuit.
Moisture is generated at the downstream of the compressed air line.	The bypass valve is open.	- Be sure to fully close the bypass valve.
	Condensate is not drained from the motor type auto drain.	<ul style="list-style-type: none"> - Check the draining piping is not used in an upward direction nor bent. - Check the motor type auto drain. - Check the ball valve is open.
	The piping of a different system without an air dryer joins the piping after the product.	<ul style="list-style-type: none"> - Install another air dryer (this product) in that system. - Keep the two systems separate.
The compressed air pressure is too large.	The valves at the inlet and outlet of the piping of the product are not fully opened.	- Be sure to fully open the valves at the inlet and outlet of the product.
	The air filter, etc. installed in the compressed air piping has got clogged.	- Replace the element of the air filter. (Follow the Operation Manual of the equipment.)

5.2 Reset of protective equipment

While the product is stopped, the protective equipment in the refrigerating circuit is operating, and needs to be reset manually. Refer to page 1-1 for the positions of protective equipment.

Refer to "5.1 Troubleshooting" and eliminate the cause that triggered the protective equipment.

Danger
Turn off the Start / Stop switch.

Reset of thermal relay

1. Turn off the Start / Stop switch of the product.
2. Remove the front panel. On the upper left of the terminal block for the power supply there is a thermal relay (Figure on the right)
3. Check the operation indicator window of the thermal relay does not show green.
4. Press the reset button (blue). Check the operation indicator window is showing green.
5. Put back the front panel.
6. Turn on the Start / Stop switch to restart operation.

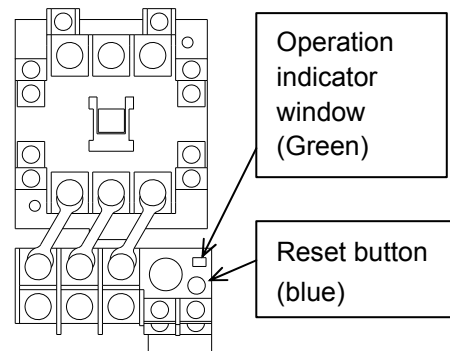

Thermal relay

Reset of high and low pressure switch

1. Turn off the Start / Stop switch of the product.
2. Remove the front panel. On the upper right of the terminal block for the power supply there is a high and low pressure switch (Figure on the right)
3. Press the red reset button.
4. Put back the front panel.
5. Turn on the Start / Stop switch to restart operation.

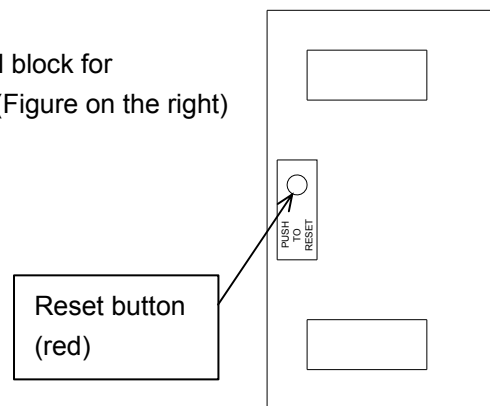

High and low pressure switch

6
Reference

6.1 Specification table

Item		Model	IDF370D-3	
Operating range	Fluid		Compressed air	
	Inlet air temperature	°C	5 to 50	
	Inlet air pressure	MPa	0.15 to 0.97	
	Ambient temperature (humidity)	°C	2 to 43 (Relative humidity 85% or less)	
Rating	Air flow capacity m ³ /min	Standard conditions (ANR) ^{Note 1)}	50Hz	54
			60Hz	65
	Inlet air pressure	MPa	0.7	
	Inlet air temperature	°C	35	
	Outlet dew point	°C	10	
	Amount of cooling water (50/60Hz) ^{Note 2)}	L/min	100	
	Cooling tower capacity ^{Note 3)}	kW(RT)	38.5 (8.5)	
	Cooling water pressure drop (50/60Hz)	MPa	0.05 (excluding automatic fluid filling valve)	
Fluid port size		1 1/4 union		
Electric characteristic	Power supply voltage (frequency) ^{Note 4)}		Three-phase AC200V (50Hz) / AC200,220V (60Hz)	
	Power consumption (50/60Hz) ^{Note 5)}	k W	11.6	
	Running current ^{Note 5)}	A	36.5	
Applicable ground fault circuit interrupter capacity (Sensitivity current: 30mA) ^{Note 6)}		A	50	
Refrigerant			R407C (HFC)	
Condenser			Water-cooled	
Port size			6B JIS 10K FF flange	
Weight	kg		1100	
Applicable air compressor (screw type) output (referential)		kW	370	
Applicable standards			Class 2 pressure vessel	

Note 1) Air flow capacity under the standard condition (ANR) [20°C atmospheric pressure and 65% relative humidity].

Note 2) Value when cooling water inlet temperature is 32 °C and with rated load.

Note 3) Calculated at 1 RT = 4.535kW

Note 4) If the product is subjected to a short power outage (including voltage sag), it may take a long time to start operating normally or be unable to restart normally due to the protective equipment triggered after the power is recovered.

Note 5) The value shown in it is a reference value at rated condition and is not the guaranteed value.

Note 6) Ground fault circuit interrupter is not mounted in product other than option "R".

Motor type auto drain specifications

Fluid	Compressed air
Operating cycle	4 times per minute
Operating time	For 8 sec/min
Power supply	AC200V (50/60Hz)
Power consumption	4W

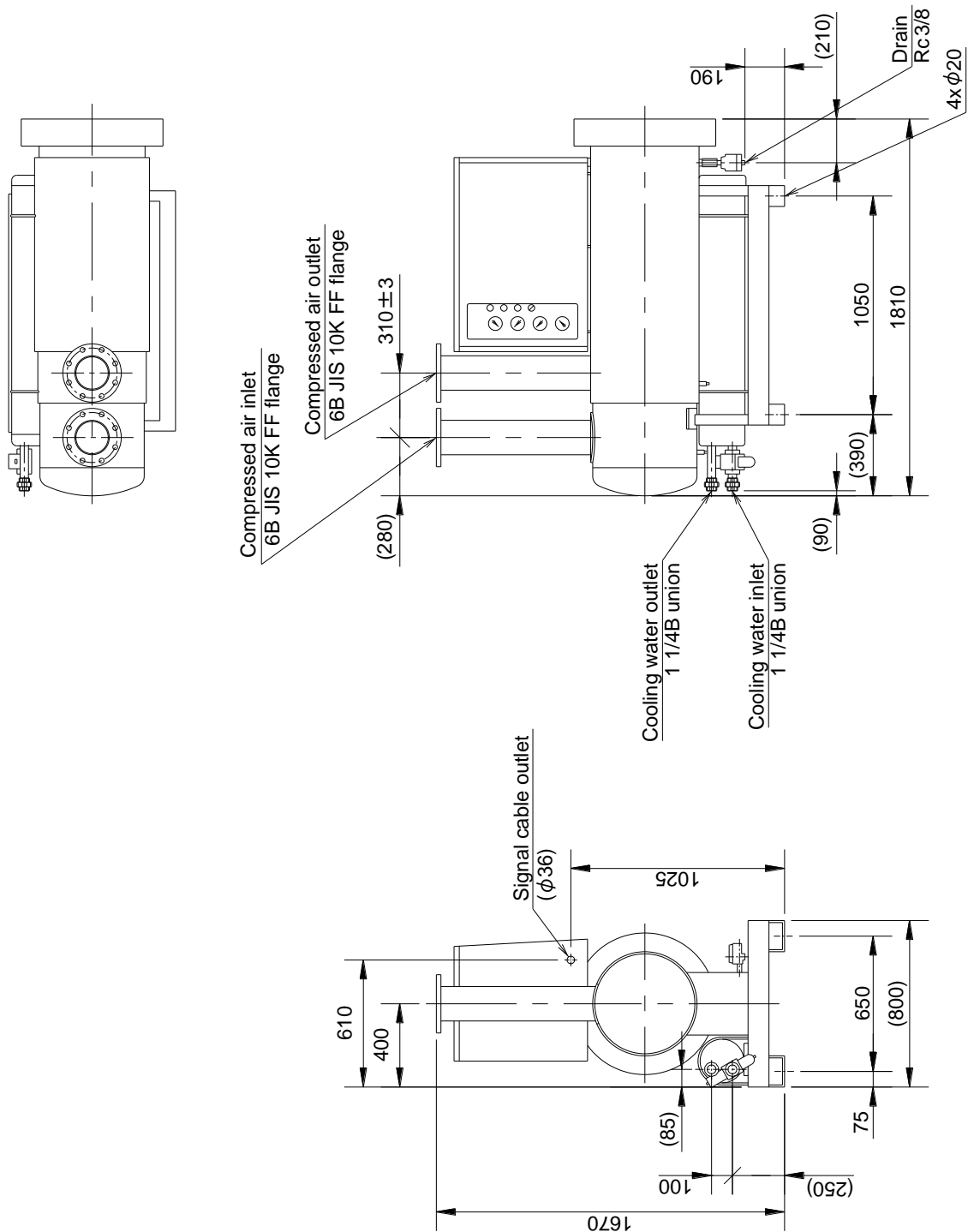
6.2 Outer dimensions

6.3 Electric wiring diagram

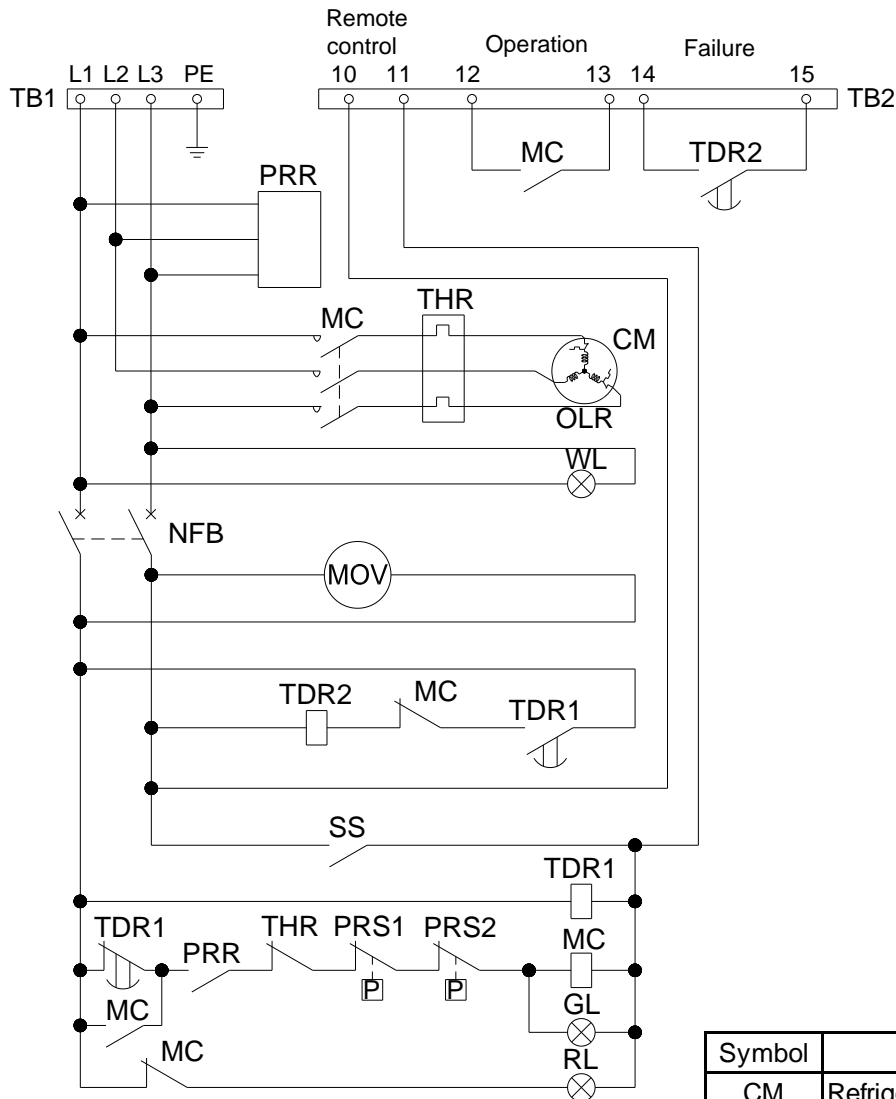

Symbol	Description
CM	Refrigerating compressor
OLR	Overload relay
MC	Magnetic contactor
TB1	Terminal block
TB2	Terminal block
TDR1	Time delay relay
TDR2	Time delay relay
PRR	Phase reversal relay
SS	Start / Stop switch
THR	Thermal relay
PRS1	High and low pressure switch
PRS2	Differential pressure switch
MOV	Motor type auto drain
WL	Power supply lamp (white)
GL	Operation lamp (green)
RL	Failure lamp (red)
NFB	No-fuse breaker

6.4 Pneumatic and refrigerant circuits and their functions

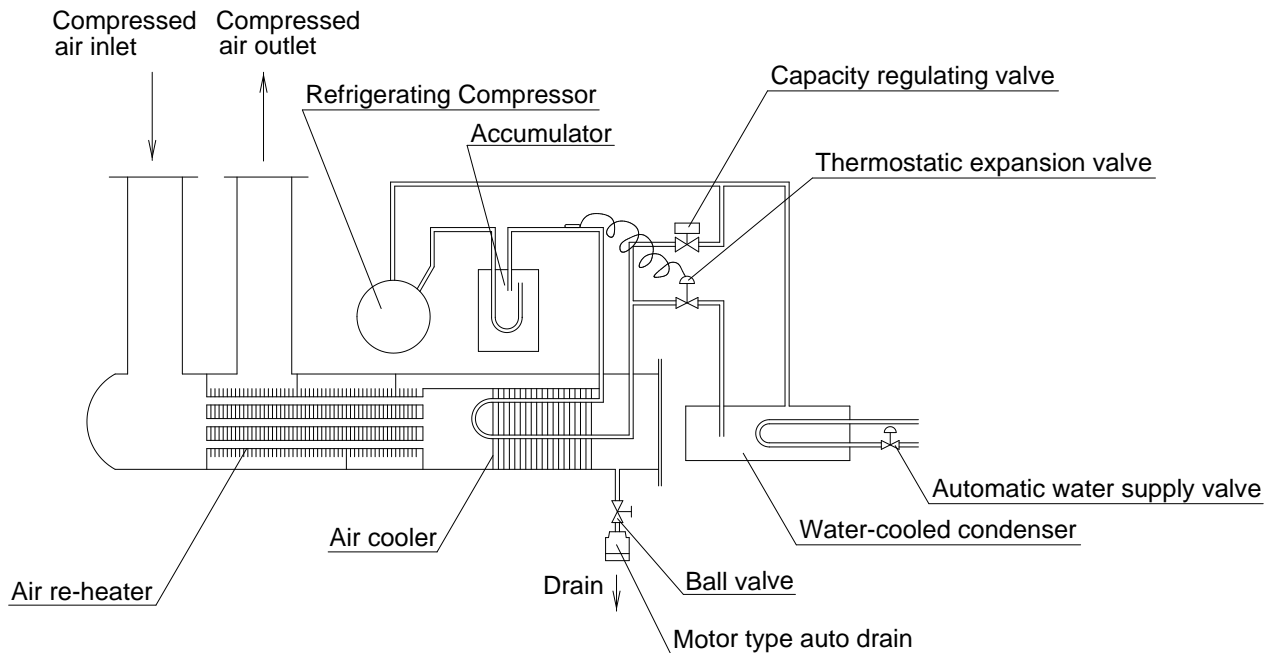

Pneumatic circuit

High temperature humid air from the air compressor passes through the air re-heater and is pre-cooled by dehumidified cool air. Then it is cooled to the specified temperature by the air cooler using the evaporation heat of refrigerant. At this time, the moisture generated by condensation are automatically exhausted by the auto drain. The cooled and heat is exchanged with hot air that flows into the air re-heater. It is supplied as dry warm air without "sweating" in the piping system.

Refrigerant circuit

The HFC gas contained in the refrigerant circuit is compressed by the compressor, and cooled and liquefied by the condenser. When passing through the thermostatic expansion valve, the HFC gas is regulated and its temperature decreases. While passing through the cooler part, it evaporates rapidly, taking the heat from the compressed air, and is sucked in by the compressor. The capacity regulating valve opens when the compressed air has been cooled sufficiently, and prevents condensed water from being frozen by excessive cooling.

Revision
Rev A : Apr,2023

SMC Corporation

4-14-1, Sotokanda, Chiyoda-ku, Tokyo 101-0021 JAPAN

Tel: + 81 3 5207 8249 Fax: +81 3 5298 5362

URL <https://www.smcworld.com>

Note: Specifications are subject to change without prior notice and any obligation on the part of the manufacturer.
© 2023 SMC Corporation All Rights Reserved