



Operation Manual

PRODUCT NAME

Heatless Air Dryer

MODEL / Series

ID20□-□02□

ID30□-□04□

ID40□-□04□

ID60□ -□06□

Please read this manual prior of using the air dryer. Keep the manual readily available for reference.

SMC Corporation

To Customers

Thanks for purchasing SMC Heatless Air Dryer.

This operation manual must be read and understood throughoutly before handling. It provides all essential information for maximizing product operating efficiency, as well as, for safe and longer life span operation.

For safety operation of SMC Refrigerated Air Dryer, read thoroughly and follow stated safety instructions, as well as regulation stated within ISO 4414^{*1} & JIS B 8370^{*2}.

*1) ISO 4414: Pneumatic fluid power – General rules and safety requirements for systems and their components

*2) JIS B 8370: Pneumatic fluid power – General rules relating to systems

This manual explains about installation and operation of the product. Only those who have thorough understanding of the fundamental operating procedure or have basic knowledge and skills of handling industrial product for the installation and operation of the product are qualified to perform installation and operation.

The contents of the operation manual and the other documents attached to the product cannot become a part of the contract clause or cannot change and modify existing agreements, promises, and relationship.

Any statements contained in the operation manual cannot be newly guaranteed and modify existing guarantee certificate.

You are not allowed to copy any part of this operation manual for usage of third person without informing it to us beforehand.

<p>Caution: Please understand that the contents of this operation manual are subject to changed without previous notice.</p>
--



Table of Contents

Chapter i	Safety Instructions	
i - 1	Warning: Before Using Air Dryer	i - 1
i - 1 - 1	Meanings of signs: Danger, Warning, Caution	i - 1
i - 2	Danger Classifications / Position of Danger warning label	i - 3
i - 2 - 1	Danger Classifications	i - 3
i - 2 - 2	Danger of Electricity	i - 4
i - 2 - 3	Danger of Compressed Air Circuit	i - 4
i - 3	Limited warranty and Disclaimer / Compliance Requirements	i - 5
Chapter 1	Name of each Parts	
1 - 1	Name of each Parts	1 - 1
Chapter 2	Transportation / Installation	
2 - 1	Transportation	2 - 1
2 - 2	Installation	2 - 1
2 - 2 - 1	Location	2 - 1
2 - 2 - 2	Anchorage	2 - 2
2 - 2 - 3	Air piping	2 - 2
2 - 2 - 4	Electric wiring	2 - 3
2 - 3	Cautions about Reinstallation	2 - 5
Chapter 3	Operation / Shutdown	
3 - 1	Check points before operation	3 - 1
3 - 2	Operation	3 - 1
3 - 3	Shutdown	3 - 2
3 - 4	Check points before restart	3 - 2
3 - 5	Precautions for long-term non-operation	3 - 2
Chapter 4	Maintenance	
4 - 1	Daily inspection	4 - 1
4 - 2	Periodical Maintenance	4 - 1
4 - 2 - 1	Exchange of absorbent	4 - 1
4 - 2 - 2	Service parts	4 - 2
4 - 2 - 3	Exchange of other parts	4 - 4
4 - 2 - 4	Check points book	4 - 6
Chapter 5	Troubleshooting	
5 - 1	Cause and countermeasure of errors	5 - 1
5 - 1 - 1	Failure diagnosis chart	5 - 1
5 - 1 - 2	Breakdown cause investigation points and measures	5 - 2
Chapter 6	References	
6 - 1	Specifications	6 - 1
6 - 2	Externals dimensional drawing	6 - 2
6 - 3	Electrical Circuit	6 - 3
6 - 4	Structure and operation principles	6 - 4

 **Safety Instructions**

 **Before use, read and comprehend important cautionary notification well on this operation manual.**

i-1 Warning: Before Using Air Dryer

In this chapter, the stated contents are especially about safety way to use the product. for customer.
An Air Dryer is installed on the downstream of the air compressor to remove moisture. We, manufacturer, cannot take any responsibility if you use it for any other purpose.
An Air Dryer works with high voltage and has some parts that gets hot or rotates during operation. Ask vendor if you need component replacement and servicing.
Not only people handle the air dryer but every people who perform maintenance on or do works related to it should read safety instructions on this operation manual before handling.
This operation manual is not a general safety manual which is practiced by safety training representatives. People who handle this product or work around it need to take training to comprehend inherent risks of it and master measures for safety.
It is usually responsible for super visor to follow the safety instructions, but each operator or maintenance representative should do daily operations on their own head.
Operators and maintenance representatives should take the safety of working place and work environment into account.
It is necessary to think of the safety of working place and work environment for each task
Take enough safety training before the operation training. It is very dangerous to do operation training without any safety training. Operation training must be paid attention to its safety.

i – 1 – 1 Meaning of Signs: Danger, Warning, Caution

These safety instructions are intended to prevent hazardous situation and/or product damage. These instructions indicate the level of potential hazard by signs “**Danger**”, “**Warning**” or “**Caution**”. Contents with these signs state about important instructions concerning safety. Confirm where those signs are, and read and comprehend notices and cautionary notices well before handling.

“**Danger**”, “**Warning**” or “**Caution**” is the order of importance (Danger>Warning>Caution). Followings are the meanings of those signs.

 Danger
Statements with the “Danger” sign explain about conditions in which there is a possible result of serious injury or loss of life if someone handles wrongly during operation or maintenance and did not follow the procedure to avoid danger.



Warning

Statements with the “Danger” sign explain about possibilities that can result in serious injury or loss of life if someone handle wrongly during operation or maintenance and did not follow the procedure to avoid danger.





Caution

Statements with the “Danger” sign explain about possibilities that can result in injury or product damage if someone handles wrongly during operation or maintenance and did not follow the procedure to avoid danger.

i-2 Danger Classifications / Position of Danger Warning Label

To protect operator's safety, we group danger into some types uniquely and attached labels indicating those types. Confirm the contents of the danger types and positions of the labels before operation.

	Warning
<p>No one but professionals should operate an air dryer.</p> <p>Transportation, installation, and maintenance involve risks. These should be done by someone who have enough knowledge and experience about this product and incidental devices.</p> <p>No one but our service personnel or qualified person should open the cover panel of this product.</p>	

	Warning
<p>Should any problem occur, address it according to statements on this manual.</p> <ul style="list-style-type: none"> • Identify problems according to “Chapter 5 Troubleshooting.” • Ask repair and maintenance. 	

	Warning
<p>The product should not be operated in the event of any problems.</p> <p>When the product gets out of order, shutdown it immediatery, and contact our service person or qualified person.</p>	

i – 2 – 1 Danger Classifications

Specific danger classification of this product is as follows.

Danger of Electricity



Since this product runs at high voltage, there is the danger of electric shock. So, we display a symbol with indications, “**Danger**”, “**Warning**” or “**Caution,**” on the product and this manual.

Danger of Heat



Since this product becomes hot while driving, there is the danger of burn injury. So, we display a symbol with indications, “**Danger**”, “**Warning**” or “**Caution,**” on the product and this manual.

i – 2 – 2 Danger of Electricity

Inside of this product, there is power-supplying section with high voltage separated by the cover panel. Do not operate the product without the cover panel.

No one but trained qualified person should operate or inspect in the power transmission sections.

**Warning**

Read with caution and pay attention to the notations on danger warning labels.

Do not remove or rub danger warning labels.

Confirm the positions of danger warning labels.

i – 2 – 3 Danger of High Heat**Warning**

Since this product has parts that become hot during operation, there is the danger of burn injury resulting from contact with them. What is more, there is also the danger of burn injury due to remaining heat after the power supply is cut. Therefore, wait until the temperature of hot parts become 50°C and below.

i – 2 – 4 Danger of Compressed Air Circuit**Warning**

Before replacing or cleaning parts, be sure to bleed compressed air remain inside of the product until the gauge indicates “0”. If you do not do this air-bleeding, there would be the great danger of unexpected accident, such as shooting out of parts when they are being unscrewed.

i-3 Limited warranty and Disclaimer / Compliance Requirements

The product used subject to the following "Limited warranty and Disclaimer" and "Compliance Requirements. Read and accept them before using the product.

Limited warranty and Disclaimer

1. The warranty period of the product is 1 year in service or 1.5 years after the product is delivered. Also, the product may have specified durability, running distance or replacement parts. Please consult your nearest sales branch.
2. For any failure or damage reported within the warranty period which is clearly our responsibility, a replacement product or necessary parts will be provided.
This limited warranty applies only to our product independently, and not to any other damage incurred due to the failure of the product.
3. Prior to using SMC products, please read and understand the warranty terms and disclaimers noted in the specified catalog for the particular products.

Compliance Requirements

1. The use of SMC products with production equipment for the manufacture of weapons of mass destruction (WMD) or other weapon is strictly prohibited.
2. The exports of SMC products or technology from one country to another are governed by the relevant security laws and regulation of the countries involved in the transaction. Prior to the shipment of a SMC product of a SMC product to another country, assure that all local rules governing that export are known and followed.

Caution

**The Product is provided use in manufacturing industries.
The product herein described is basically provided for peaceful use in manufacturing industries.
If considering using the product in other industries, consult SMC beforehand and exchange specifications or a contact if necessary.
If anything is unclear, contact your nearest sales branch.**

Caution

**SMC products are not intended for use as instruments for legal metrology.
Measurement instruments that SMC manufactures or sells have not been qualified by type approval tests relevant to the metrology (measurement) laws of each country. Therefore, SMC products cannot be used for business or certification ordained by the metrology (measurement) laws of each country.**

1 Name of each Parts

1-1 Name of each Parts

• ID20 to 30

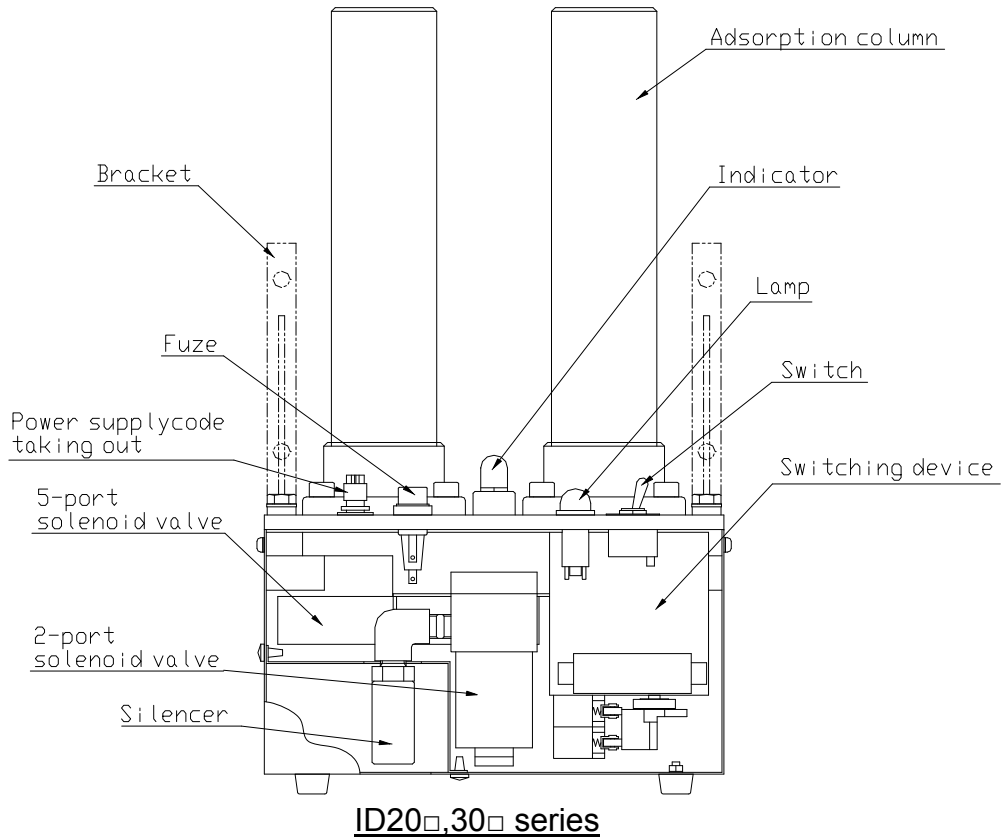

• ID40 to 60

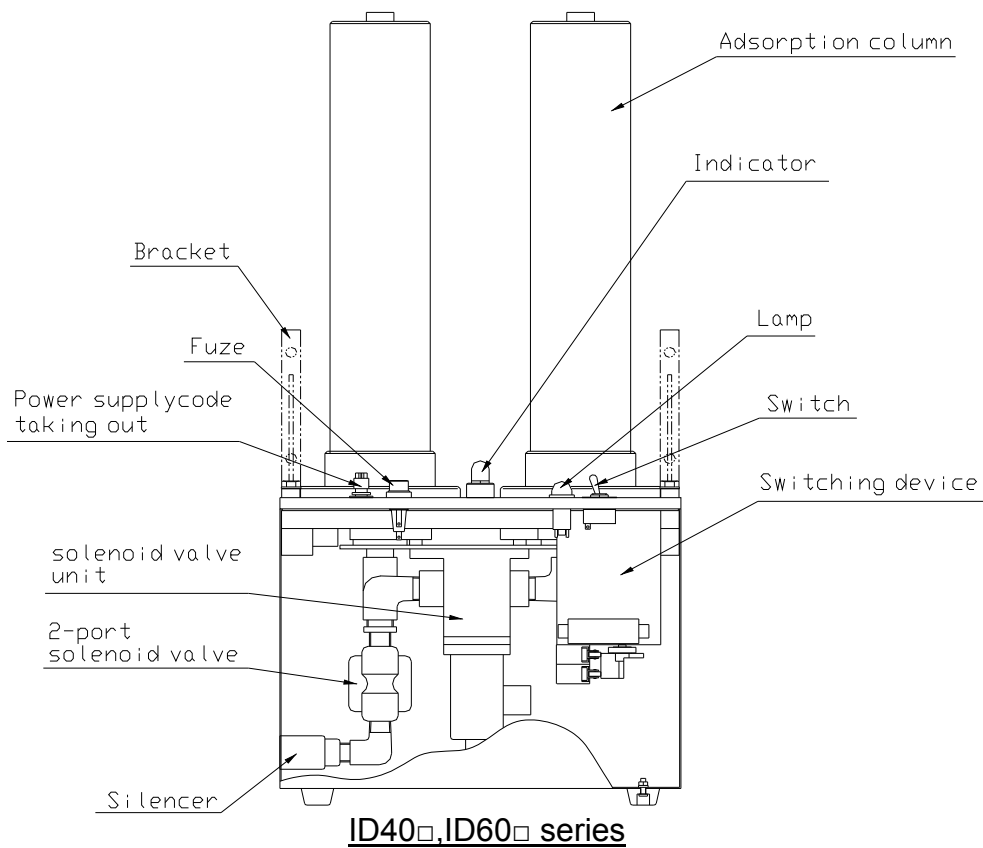

2**Transportation / Installation****Warning**

Use the product in the right way. During Installation, operation, maintenance, and check, you should be careful in keeping the safety of human body.

**Caution**

Transportation, installation, and maintenance including dangerous work must be done by a personnel who has enough knowledge and experience about the product and the system.

2-1 Transportation

When you transport the product, you should follow these instructions below.

- You should uplift the product from the base surface with careful attention to prevent falling sideways and drop.
- Do not bring the product lying sideways. If you lay it sideways, it will be broken.
- Do not hang up the product.
- Do not transport the product with any part such as an air filter mounted on the fittings at the air inlet or outlet port of the product. If it is unavoidable to transport the product with such a part mounted, support the part with a bracket to prevent the product from being affected by vibration during transportation.

**Warning**

Those instructions above must be followed because the product is so heavy that it carries a great risk to transport.

ID20* to 60* are 7 to 25kg . They must be transported by more than 2 person or transport it by truck.

2-2 Installation**2-2-1 Location**

The product should not be used or stored in the circumstances as follows.

Those circumstances will cause not only malfunction but also failures.

- Environment where the product is exposed to rainwater, moisture vapor, salty water, oil and so on.
- Locations where dust or particles are.
- Locations where inflammable or explosive gas are.
- Locations where corrosive gas, solvent, combustible gas are.
- Locations that receive direct sunlight or where radiant heat is generated.
- Locations where ambient temperature is beyond following range:
 - On-stream: 5 to 50°C
 - Storage: 0 to 50°C (when there is no drain water inside of the piping)
- Locations where temperature changes rapidly.
- Locations where strong electromagnetic noise is generated.
 - (locations where electromagnetic field, surge is generated)
- Circumstances where static electricity is produced or discharged through the body of the product.

- Locations where strong high frequency wave is generated.
- Locations where danger of thunder is apparent.
- Locations by loading on vehicles, marine vessels, and so on.
- Locations whose altitude is higher than 2,000 meters.
- Circumstances where strong vibration or impact are transmitted.
- Circumstances where too much force and weight are put on the body of the product that causes it to deform.
- The air used to reproduce the absorbent and air which passed Indicator is exhausted outside of Heatless type Air Dryer. Please use it in the place without the problem even if it exhausts it.
- Place without problem even if air is exhaust from outlet of product.
- Condition which has sudden pressure/flow rate changes.



Warning

Do not use and store in environment having compressed air or ambient atmosphere which includes the following substances. It could result in failure of the product and damage of components, which leads to injury.

- Corrosive gas, Organic solvent, Chemicals

2-2-2 Anchorage

- The air dryer should be installed on a vibration-free, stable, horizontal flat surface.
- Refer to "Chapter6 6-2 Externals dimensional drawing" for the dimensions.

2-2-3 Air piping

- Connection to the inlet and outlet of compressed air should be made removable by using union and so on.
- When mounting any part such as an air filter on the fitting at the compressed air inlet or outlet port, support the part to prevent excessive force from being applied to the product
- Be careful not to let the vibration of the air compressor transmit.
- If the temperature of compressed air on the inlet side is higher than 50°C, place an aftercooler after the air compressor. Or, make the temperature of the place where the air compressor is installed lower than 50°C.
- If the air supply makes high pressure fluctuation (pulsation), take any countermeasures such as installing air tank.
- Flash the piping sufficiently in order to avoid any foreign substances such as dust, sealing tape, liquid gasket, etc. when piping before piping connection. Foreign substances in the piping can cause malfunction or drainage failure.
- Use pipes and fittings that have enough endurance against the operating pressure and temperature. And connect it firmly to prevent air leakage.
- Please install it on the air pressure line with a supply capacity "Flowing quantity of the necessary outlet air + flowing quantity of the reproduction air" above-mentioned.
- Please install Mist separator (AM series) at upper stream of the ID.
The capillary organization of the absorbent might be blockaded when the oil mist and the foreign particles exist in compress air, as the result, the adsorption ability decreases remarkably and at the same time the life of the absorbent is shortened.
And also the inflow of drain should be avoided as it will make early deterioration of the absorbent.
Please install Mist separator or Micro mist separator (AMD series) at the down stream when you want to avoid the contaminants with the powder etc. of the absorbent.

- Please install Bypass circuit with Stop valve when you cannot stop compress air when maintenance is checked.(exchange of the absorbent etc.)
- Please install it on either of the M4 screws of the IN/OUT piping when you put up the earth.

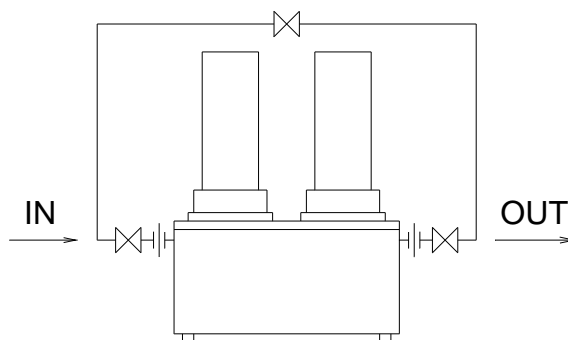

- Please set up frozen Air Dryer on the first side when you use Z type (low dew point).
- Please install it on the second side of Heatless type Air Dryer when you install the reducing valve. It installs on the first side, and the dehumidification ability of the air pressure cannot be demonstrated when using it low.

2-2-4 Electric Wiring

⚠ Warning

No one but qualified person should do the wiring work.

- Before wiring, you must cut the power off for safety. Do not work under any energized conditions.
- Supply power from a stable place, which is free from the effect of surge.
- Ensure that a Ground Fault Circuit Interrupter(GFCI) with appropriate capacity for earth leakage and load is used in the power supply of the product to prevent electrical shock and burnout. See “6-1 List of specifications” for details.
- Supply power for the product should meet the specifications.
- The product should be grounded for safety.
- Do not connect the earth to a water pipe, a gas pipe, or a lightning rod.
- Do not plug too many leads into a single socket. That causes exothermic heat or fire.
- Do not convert the wiring to use.

There are two methods depends on model (specified power)

ID200 to 600 / 201 to 601 (100/110V specified)

- Insert the power plug into an outlet of 100/110V AC
- Do not extend the power cable using power strip and so on. That causes decrease of the voltage and the product cannot be operated.

ID205 to 605 / 206 to 606 (200/220V specified)

- Remove the terminal block cover or the rear cover in the rear of the product, and connect the power (200/220V AC) to the terminal block.
- Please install it on either of the M4 screws of the IN/OUT piping when you put up the earth.

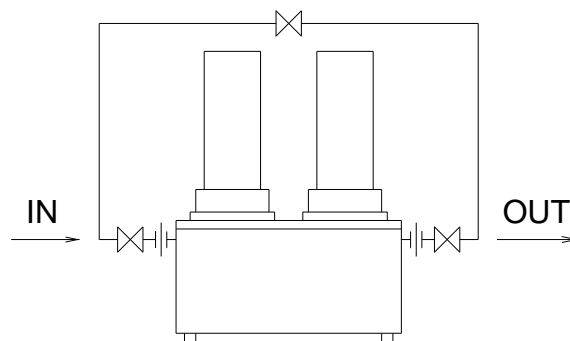
**Specification of power cable**

The following power cable is attached.

Power cable: 0.75mm²(18AWG), Two-cores, External diameter: about 2.7 ~ 5.4mm

Length of the power cable

The length of the power cable is from a product to 2m.

2-3 Cautions about Reinstallation



Caution

No one but someone who has enough knowledge about the product and incidental devices should reinstall in another place. And following instructions must be executed.

If you move the product and reinstall it into another place after some operations (including trial running), instructions that are not only following ones but also all of those in the chapter 2 should be followed.

Disassembly of the power cable

Cut off the power source when you disassemble the power cable.



Warning

**No one but qualified personnel should do the electric wiring.
Cut off the power supply for safety before the wiring. Do not work under energized condition.**

Disassembly of the air piping



Warning

**No one but qualified personnel should do the air piping.
Separate the compressor from the product for safety before removing the piping. Do not remove any piping when there is remaining compressed air pressure inside of it.**

Remove the seal tape completely after detaching the piping. Remained tape will cause imperfect cooling and failure by entering into the body of the product.

3

Operation / Shutdown**Caution**

No one but someone who has enough knowledge and experience about the product and incidental devices should operate or shut down the product.

3-1 Check points before operation

Before a trial running, check following points.

- **Installed Condition**
By visual inspection check that the product is installed horizontally.
Make sure the product is fixed enough with anchor bolts.
Do not place heavy obstacles on the product and add unreasonable loading by piping and so on.
- **Wiring Connections**
Power cord, and the earth should be connected firmly.
- **Air Piping**
Make sure the piping for compressed air is connected correctly. Those valves of IN / Out side and bypass piping of the product and of the bypass piping should be completely fasten.

3-2 Operation

Start operation according to the procedure below.

- Turn on the breaker of the main power supply. Then, turn on the illuminated switch.
- Please turn on the power supply of the air dryer after it pressurizes it. If the power supply is turned on before it pressurizes it (Especially, when pressure is low), abnormally a lot of flowing quantity of the reproduction air of the starts might become bad the movement of the check valve.
- When it does not use on, the absorbent might be damp. Please do the reproduction drive for about 20~30 minutes before closing and using the valve on the second side of the air dryer.
- The adsorption column is cut right and left and alternately every about 150 seconds and changes. Please confirm the change is regularly divided by the flow of the reproduction air.
- It can know the outlet air atmospheric pressure dew point of Heatless Air Dryer because of the change in the color of upper Indicator. The absorbent of Indicator can be used again if not discoloring to crushing (It is spheroidal usually) and brown, etc.

The outlet air atmospheric pressure dew point	* Color of Indicator (Guide)	
	Dark blue⇔Light pink	Orange⇔Dark green
-30 °C or less	Dark blue	Orange
-18 °C	Light blue	Slightly cloudy orange
-10 °C	Light pink	—
5 °C	—	Dark green

* At the time of pressure 0.7MPa and 30 °C in temperature of air

Indicator color standard

**Caution**

- Avoid frequent On/Off operation, which can cause troubles.
- Avoid using this product under the condition which has sudden pressure/flow rate changes. Otherwise, drain (condensed water) may flow out to the secondary piping.

3-3 Shutdown

- Turn off the switch.
- The lamp will go out and then, the operation will be stopped.

3-4 Check points before restart

Check following points before you start operation. If any abnormalities occur, immediately stop the operation. Turn off the illuminated switch of the product and then the breaker to the power supply.

- There is no leakage of compressed air.
- Compressed air pressure, temperature, flow rate, and ambient temperature meet the specifications.
- There are no abnormal sound, vibration, or smelling.

3-5 Precautions for long-term non-operation

- If the product will not be operated for more than 24 hours, for example at the weekend, turn off the ILS (Switch with lamp) or power supply, for energy saving and safety. It is also recommended to release the pressure.

4

Maintenance

4-1 Daily Inspection

Check following points during usual operations. If you find some problems, immediately stop the operation and refer to "Chapter 5 Troubleshooting" as soon as possible.

- There is no air leakage
- The running lamp is lighting during operation
- The adsorption column is cut right and left and alternately every about 150 seconds and changes. Please confirm the change is regularly divided by the flow of the reproduction air.
- There is no abnormal sound or vibration coming up from the product.
- There are no abnormal smell or smoke coming up from the product.

4-2 Periodical Maintenance

Please demonstrate the performance of Air Dryer enough, and check according to the check point's book on 4-2-4 to prevent the breakdown beforehand. Moreover, please execute maintenance as follows.

4-2-1 Exchange of absorbent

Please exchange the absorbent when the performance decreases by using a long term due to deterioration in the absorbent etc. It can know the outlet air atmospheric pressure dew point of Air Dryer because of the change in the color of upper Indicator. The absorbent of Indicator can be used again if not discoloring to crushing (It is spheroidal usually) and brown, etc.

The outlet air atmospheric pressure dew point	* Color of Indicator (Guide)	
	Dark blue⇔Light pink	Orange⇔Dark green
-30 °C or less	Dark blue	Orange
-18 °C	Light blue	Slightly cloudy orange
-10 °C	Light pink	—
5 °C	—	Dark green

* At the time of pressure 0.7MPa and 30 °C in temperature of air

Indicator color standard**Caution**

- If oil mist is adsorbed on the indicator silica gel, the color may change to brown or black. In such a situation, it cannot be reused. Replace it with a new one. Also, replace the element of mist separator connected to the inlet side of this product at the same time.
- The outlet air atmospheric pressure dew point indicated by indicator color is not accurate. If you need an accurate dew point, use a dew point meter.

4-2-2 Service parts
Adsorption cylinder structural chart

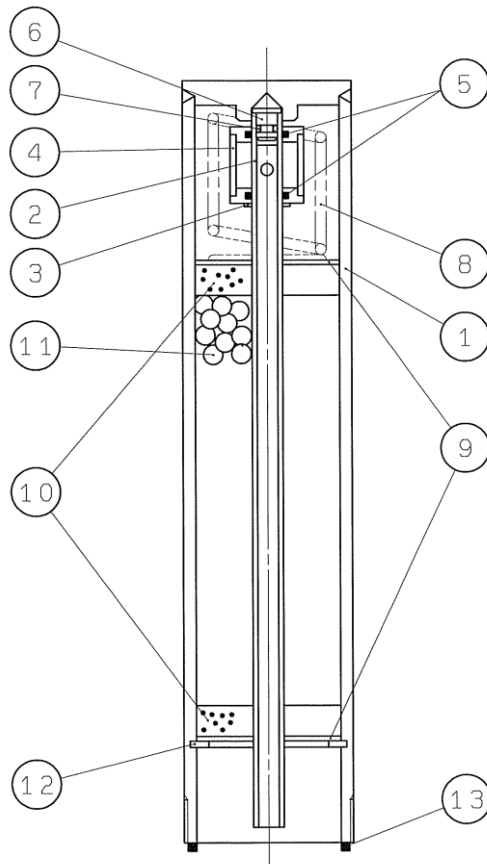

Adsorption cylinder part table

Number	Name of articles	Number of the table
1	Case	-
2	Pipe	-
3	Circle of stopping Me of E type	-
4	Filter element	Table 1
5	"O"ring	
6	Plug	-
7	"O"ring	-
8	Spring	-
9	Panting metal	-
10	Filter element	Table 2
11	Adsorbent	
12	Snap ring	-
13	"O"ring	Table 3

Decomposition

1. Please pull out Stop valve of the piping line and pull out the pressure of shutting Air Dryer. Please turn the adsorption column counterclockwise after confirming pressure came off and remove. (Width of across flat ID40□:22, ID60□:24)
2. Please make the adsorption column upper and lower and inverted. (Threaded portion is done up.)
3. ⑫ please detach C type stop circle for the hole. It is convenient to use a special tool (Snap ring installation Pliers) to detach C type stop circle for the hole.
4. ⑨ please detach Panting metal and ⑩ filter element.
5. ① please make the case inverted, and remove an inside absorbent.
6. ② please pull Pipe, and take out internal parts.
7. Please wash each part by Air blow.
8. ④ When the air filter has caused stopped up, it is necessary to exchange it.
9. ⑩ please exchange filter of ⑪ and ⑬“O”ring at each exchange of the absorbent.

Class addition

1. ④ please put ⑤“O”ring 2 in the ditch of the filter element. Please install this filter element in ②Pipe.
2. ① please put case and ⑧ Spring.
3. Please encase the pipe of clause 1.
4. ⑨ please put Panting metal and ⑩ filter element sequentially.
5. Please put a new ⑪ absorbent from the ditch of C type stop circle for the hole 10mm below. Please fill the absorbent while lightly giving happen the vibration. When filling the adsorbent, please to come to the center ② pipe.
6. Please put a new ⑫ filter element and ⑬ Panting metal sequentially.
7. ⑭ please put C type stop circle for the hole in the ditch of ① case.
8. Please confirm the foreign body is not mixed in ②Pipe when the case is made inverted (Threaded portion is done below).
9. ① Grease is spread on the threaded portion of the case, and the adsorption column must screw in the main body.

Table 1 Replacement part

Number	Name of articles	Purchase order number				quantity
		ID20*	ID30*	ID40*	ID60*	
4	Filter element	ID-S0054		ID-S0055	ID-S0056	2
5	“O”ring	KA00066		KA00072	KA00074	4

Table 2 Adsorbent set part

Number	Name of articles	Purchase order number				quantity
		ID20*	ID30*	ID40*	ID60*	
10 · 11	Standard type	ID-200S	ID-300S	ID-400S	ID-600S	1
(Filter element, Adsorbent, “O”ring)						
10 · 11	Low dew point type (ID*0*-*-Z)	ID-200Z	ID-300Z	ID-400Z	ID-600Z	1
(Filter element, Adsorbent, “O”ring)						

Table 3 “O”ring

Number	Name of articles	Purchase order number				quantity
		ID20*	ID30*	ID40*	ID60*	
13	“O”ring	KA00460	KA00462	KA00064	KA00455	2 (Note)

Note: Because O-ring in Table 3 is attached when Table 2 does the adsorbent set arrangements, the simulataneous arrangements are unnecessary.

4-2-3 Exchange of other parts

Please arrange through a regular exchange is unnecessary excluding the absorbent when you need exchanging in chapter 5 by the following product numbers. (Refer to the name of P1-1 or P1-2.)



Warning

- Maintenance of the air dryer should only be carried out by someone with sufficient knowledge and experience of air dryers and related equipment.
- Before carrying out maintenance, the important warnings in this manual must be thoroughly read and understood.



Danger

- When replacing or cleaning parts of the air dryer, be sure to remove the compressed air pressure inside the air dryer to "0". Never remove the bowl assembly when the air dryer is operated or air pressure remains inside. It is extremely dangerous if compressed air pressure remains inside the air dryer, as parts may come flying off at speed when loosened, or other unexpected accidents.
- This product has parts that become hot during operation and a power supply with high voltage applied. There is a risk of burns due to heat or electrification by high voltage. Even when operation is shut down after switching off the air dryer's illuminated light, there are also charging lines. When working on the charged sections, be sure to switch off the earth leakage breaker installed before starting work.
- As some parts of the air dryer will remain hot, there is a risk of burns due to residual heat after the power is switched off. So do not carry out replacement work until the temperature of these parts has fallen to 50°C or less. Wait for about 10 to 15 minutes as a guide.
- When carrying out maintenance work on the auto drain strainer and auto drain, there is a risk of touching the drain fluid during work. Please follow the safety procedure for operators specified by customer. (Example: carry out work wearing safety glasses, apron and gloves to prevent discharged fluid from touching the human body.)
- Use neutral detergent solution to clean parts such as the auto drain strainer and auto drain. Never use solvent such as thinner.
- When removing the outer casing panel or bowl assembly of the auto drain, wear gloves to prevent injuries.

<ID20□, ID30□>

Name	ID200 ID300	ID201 ID301	ID205 ID305	ID206 ID306
Ball(urethane)	φ11(product number : ID-S0026)			
Indicator	ID-DPM8			
Fuse	ID-S0028			
Lamp	ID-S0029		ID-S0030	
Switch	ID-S0031			
2-port solenoid valve	VT315-021G-X201	VT315-023G-X201	VT315-022G-X201	VT315-024G-X201
5-port solenoid valve	SY7140-1G-X404	SY7140-3G-X404	SY7140-2G-X404	SY7140-4G-X404
Packing	ID-S0057			
Silencer	AN20-02			

<ID40□, ID60□>

Name	ID400 ID600	ID401 ID601	ID405 ID605	ID406 ID606
Ball (urethane)	ID40□ : φ16(product number : ID-S0040)			
	ID60□ : φ22(product number : ID-S0049)			
Indicator	ID-DPM8			
Fuse	ID-S00028			
Lamp	ID-S0029		ID-S0030	
Switch	ID-S0031			
2-port solenoid valve set	ID-S0010-0	ID-S0010-1	ID-S0010-5	ID-S0010-6
Solenoid valve unit	ID-S0041	ID-S0043	ID-S0042	ID-S0044
Silencer	2505-003-X203			

4-2-4 Check points book

Check points book

Product name		Heatless Air Dryer						
Product model		ID20□□02□, ID30□□04□, ID40□□04□, ID60□□06□						
Check part	Check item	Check tool	Check standard	Treatment	Check time			
					Every day	1 month	6 months	1 year
Indicator	Color	Watching	Refer 4-1 page	Exchange	○			
	Operation confirmation	Soapy water	Air must flow without stopped up	Exchange		○		
Absorbent	-	-	-	Exchange				○
Filter element	-	-	-	Exchange				○
Lamp	Confirmation of display	Watching	Light while energizing	Exchange	○			
Fuse	Operation confirmation	Tester Watching	Corrode neither fusion nor the terminal	Exchange				○
Switch	Operation confirmation	Tester Watching	The power supply can be ON-OFF Do not corrode the terminal	Exchange				○
5-port solenoid valve or solenoid valve unit	Operation confirmation	Watching Ear Soapy water	Drive according to the timing diagram There must not be abnormal sound	Repair or exchange				○
			Do not leak more than EXH when testing with single goods					
2-port solenoid valve	Operation confirmation	Watching Ear Soapy water	Drive according to the timing diagram There must not be abnormal sound	Repair or exchange				○
			Air must not leak to the second side when you turn off the power supply					
Silencer	-	-	-	Washing or exchange				○
"O" ring	-	-	-	It exchanges it in 1-3 years				○
Threaded portion	Fixation	Watching	There must not be loosening	additionally tighten				○
Seal	Seal	Soapy water	Do not leak	Repair or exchange			○	
Exhaust port	Exhaust confirmation	Ear Hand	Drive according to the timing diagram	Cause of breakdown of manual Solve and refer to measures	○			
	Flowing quantity of reproduction air	Flow meter	Meet the specification. Refer to the manual.	Cause of breakdown of manual Solve and refer to measures				○

5 Troubleshooting

5-1 Cause and countermeasure of errors

Should any problem occur, inspect the following table, and if the problem cannot be solved, shut off the power supply and then contact one of our sales offices for further instructions.

5-1-1 Failure diagnosis chart

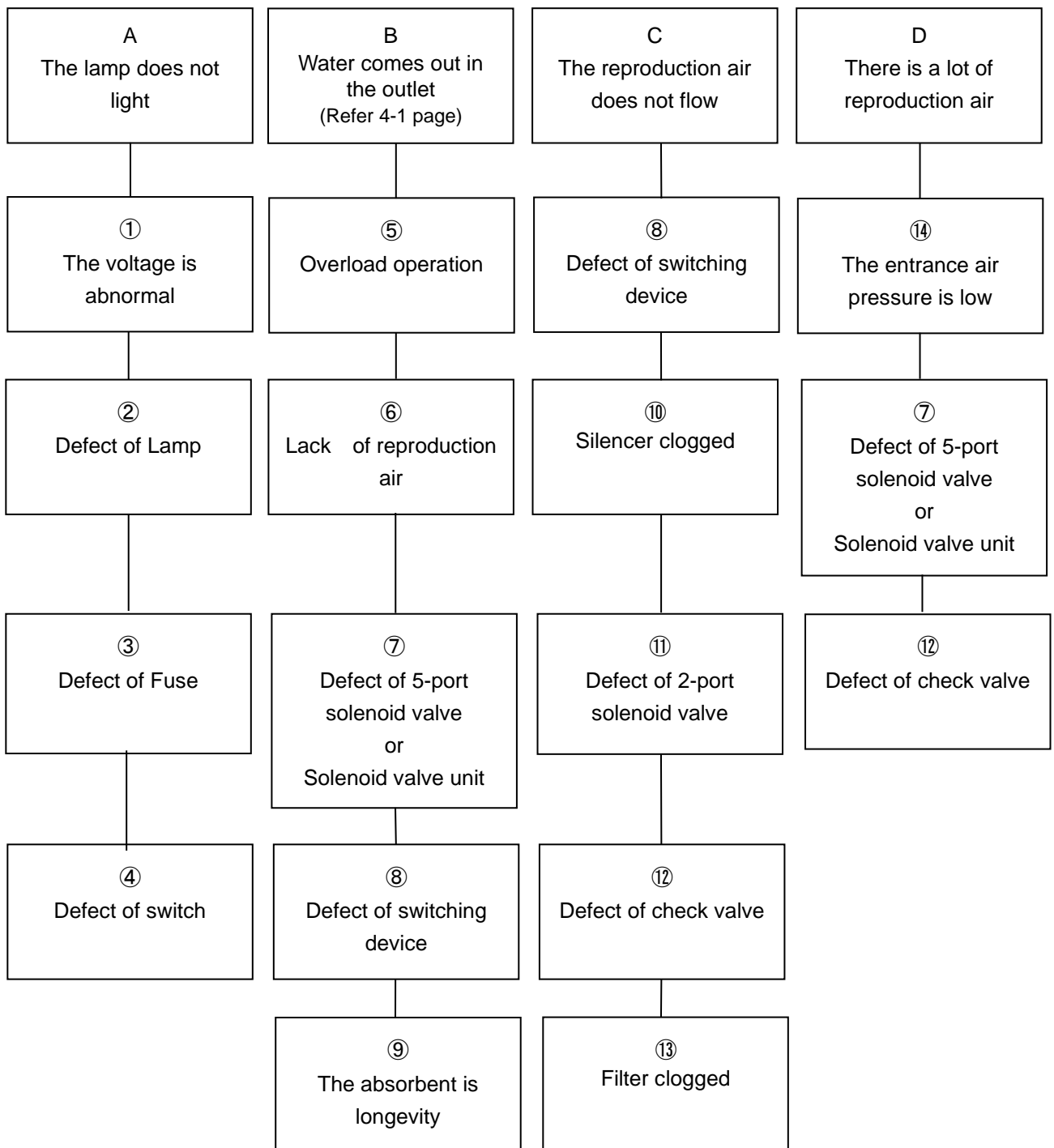

※ When the lamp has blinked, the lifetime becomes near.
(It is an image that blinks before fluorescent lamp cuts.)

5-1-2 Breakdown cause investigation points and the measures

Cause	Check part or check points	Measures
①Abnormal voltage	Measure the voltage with tester	Apply appropriate voltage
②Lamp failure 1)Abnormal voltage 2)Internal resistance burnt	See ① Check conductance between terminals with tester	Replace Replace
③Fuse failure 1)Voltage abnormal 2)Lamp failure 3)Switch failure 4)Switch device failure 5)5 port solenoid valve failure 6)2 port solenoid valve failure	Check conductance between terminals with tester See ① See ② See ④ See ⑧ See ⑦ See ⑪	
④Switch failure 1)Voltage abnormal 2>Contact failure	See ① Check conductance between terminals with tester	Replace
⑤Excess load 1)Inlet air pressure is low 2)Processed air amount is large 3)Inlet air temp is high	Measure inlet air pressure. Rated 0.3Mpa or more. Measure processed air flow. According to P1. Measure inlet air pressure. According to P1.	Increase pressure Reduce processed air amount Install after cooler
⑥Regenerated air shortage	See 「“C” Regenerated air does not flow」	
⑦5 port solenoid valve failure 1)Voltage abnormal 2)Coil burnt 3)Foreign material mixed 4)Hunting 5)Air leakage 6)Valve adherence	See ① Check conductance between terminals with tester Disassemble to check inside See 1)~3) Check foreign material at the valve seat and tightness of screwing part Check operation manually	Replace Clean or replace Clean or additionally tighten Replace
⑧Switch device failure 1)Voltage abnormal 2)Loosened cam 3)Motor burnt 4)Motor failure 5)Micro-switch failure 6)Micro-switch mount position incorrect	See ① Check tightness Check conductance between terminals with tester Check rotation 1/5rpm Check the conductance between terminals with tester Check to see if operation is based on the time chart	Additional tightening Replacement Replace Replace Correct the position
⑨Adsorbent replacement period	Check operating period Replacement period : Recommended to replacement period 1 year	Replace
⑩Silencer clogged	Check the presence of clogging	Clean or replace

Cause	Check part or check points	Measures
① 2 port solenoid valve failure 1) Voltage abnormal 2) Coil burnt 3) Foreign material mixed 4) Hunting 5) Air leakage	See ① Check the conductance between terminals with tester Disassemble to check inside See 1)~3) Check foreign material at the valve seat and tightness of screwing part	Replace Clean or replace Clean or additionally tighten
② Check valve failure 1) Ball breakage 2) Orifice clogged 3) Pipe holder failure 4) Filter element clogged 5) Click ring failure	Check the presence of flaw Check clogging Check flaw on the seat surface Check clogging Check the presence of bending	Replace Replace Replace Replace Correct it
③ Filter clogged	Check the clogging of the filter element upper part of adsorbing cylinder	Replace
④ Inlet air pressure low	Measure inlet air pressure Rated : 0.3MPa or more	Raise pressure

6

References

6-1 Specifications

Specifications		Model	ID20□	ID30□	ID40□	ID60□
Use fluid		Air				
Max. working pressure MPa		1.0		0.9		
Min. working pressure MPa		0.3				
Rating conditions	Inlet air flow rate L/min(ANR)	100	192	415	975	
	Regeneration air flow rate L/min(ANR)	20	37	85	195	
	Outlet air flow rate L/min(ANR)	80	155	330	780	
	Outlet air atmospheric pressure dew point °C	Standard Type : -30 ※1 Z Type (low dew point) : -50 ※2				
Ambient temp. and fluid temp °C		5~50				
Power supply V	ID□00	Single phase AC100/100~110 (50/60Hz)				
	ID□01	AC110 (50Hz)				
	ID□05	AC200/200~220 (50/60Hz)				
	ID□06	AC220 (50Hz)				
Permissible voltage change %		voltage ratings -15~+10				
Apparent power VA		26/21		31/27		
Tube connection caliber	Rc	1/4	1/2		3/4	
	G					
	NPT					
Mass kg		7	8.5	18.5	25	

※1 Condition ... entrance air pressure:0.7MPa
temperature of entrance air At 35 °C saturation

※2 Condition ... entrance air pressure:0.7MPa
temperature of entrance air at the time of 20 °C
(The saturation temperature: 10 °C)
[Air Dryer has been set up on the first side]

6-2 Externals dimensional drawing

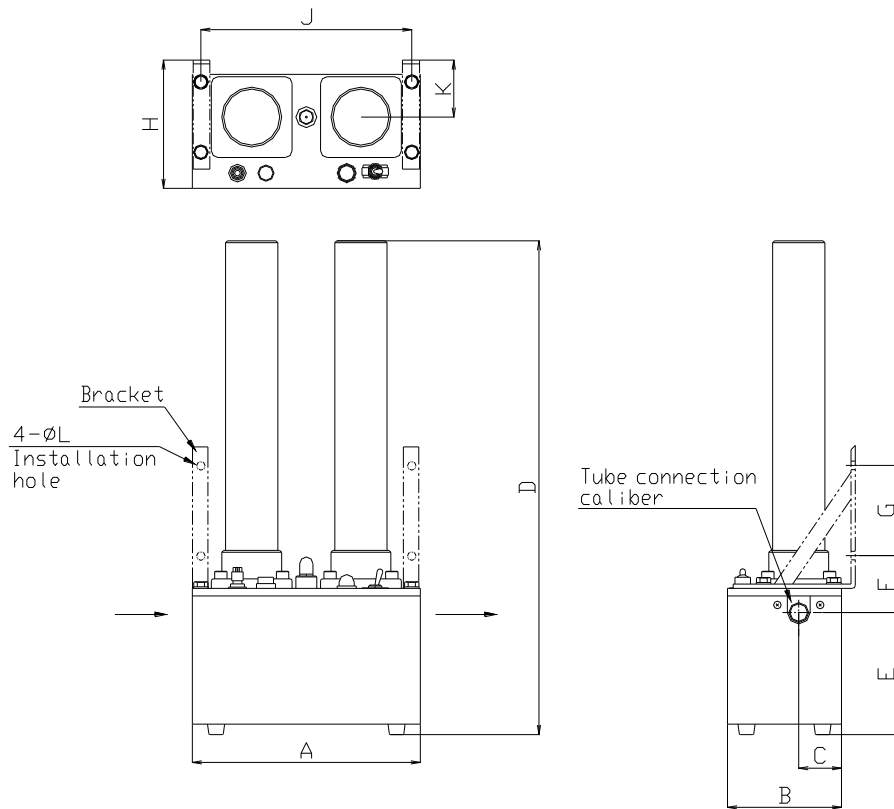

Model	Tube connection caliber	A	B	C	D	E	Size related to installation					Bracket Part No.	
							F	G	H	J	K		ϕL
ID20□	1/4	240	120	45	520	128.5	59.5	95	135	222	60	9	ID-S0058
ID30□	615												
ID40□	1/2	320	170	75	850	243.5	66.5	183	302	88	9	ID-S0059	
ID60□	3/4				961								

6-3 Electric circuit chart

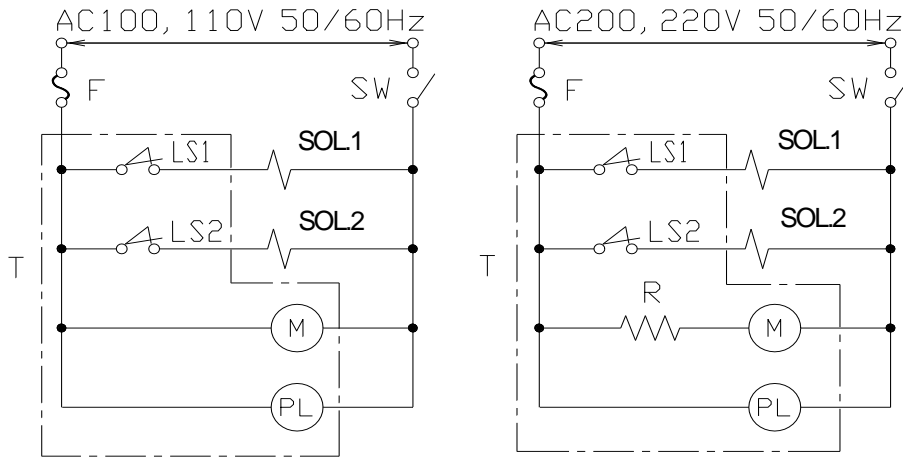

Electric circuit

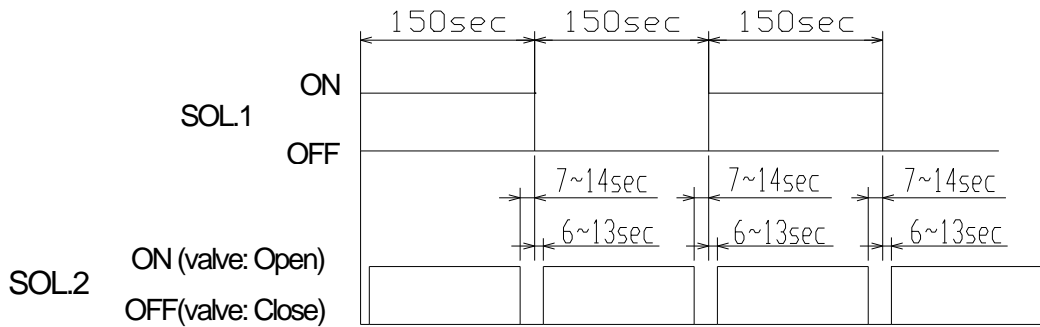

Time circuit

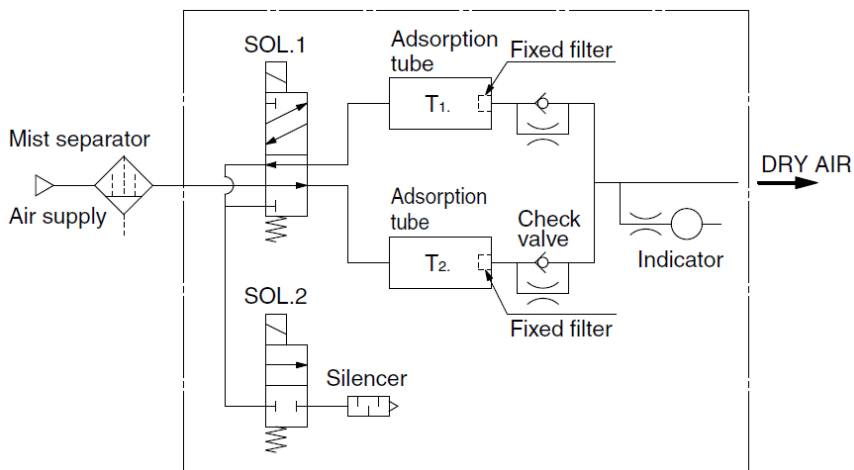

Flow sheet

Symbol	Part name	Symbol	Part name
SOL.1	5-port solenoid valve	T	Switching device
SOL.2	2-port solenoid valve	LS1,2	Micro switch
F	Fuse	M	Timing motor
SW	ON/OFF switch	R	Resistance
PL	Lamp	-	-

6-4 Structure and operation principles

The figure below is a structural chart.

T1 and T2 are containers where the absorbent was filled, T1 dehumidifies air now, and T2 is assumed the reproduction. The damp atmosphere enters adsorption column T1 through 5-port solenoid valve. The air dehumidified here goes out of check valve CV1 to street OUT. A part of dry air which passed orifice O2 is decompressed and enters adsorption column T2 because check valve CV2 at this time shuts. The moisture included in the absorbent is detached, and, it becomes dampness air, and it is discharged into atmosphere through 5-port solenoid valve and 2-port solenoid valve. Next, adsorption column T1 reproduces, adsorption column T2 enters the state of adsorption if 5-port solenoid valve is switched, and continuously steady by this repetition dry air is obtained.

The solenoid valve has been switched with the timer (switching device) which combines the motor, the cam, and the limit switch. 2-port solenoid valve is used to prevent the pulse caused at the switch of the adsorption column. That is, when reproducing, the pulse is caused in the flow of air in having switched under such a condition because it is decompressed though adsorbing it is the pressurizing under. Therefore, 5-port solenoid valve shuts 2-port solenoid valve before the switch, the adsorption column is made this pressure, and the pulse is reduced.

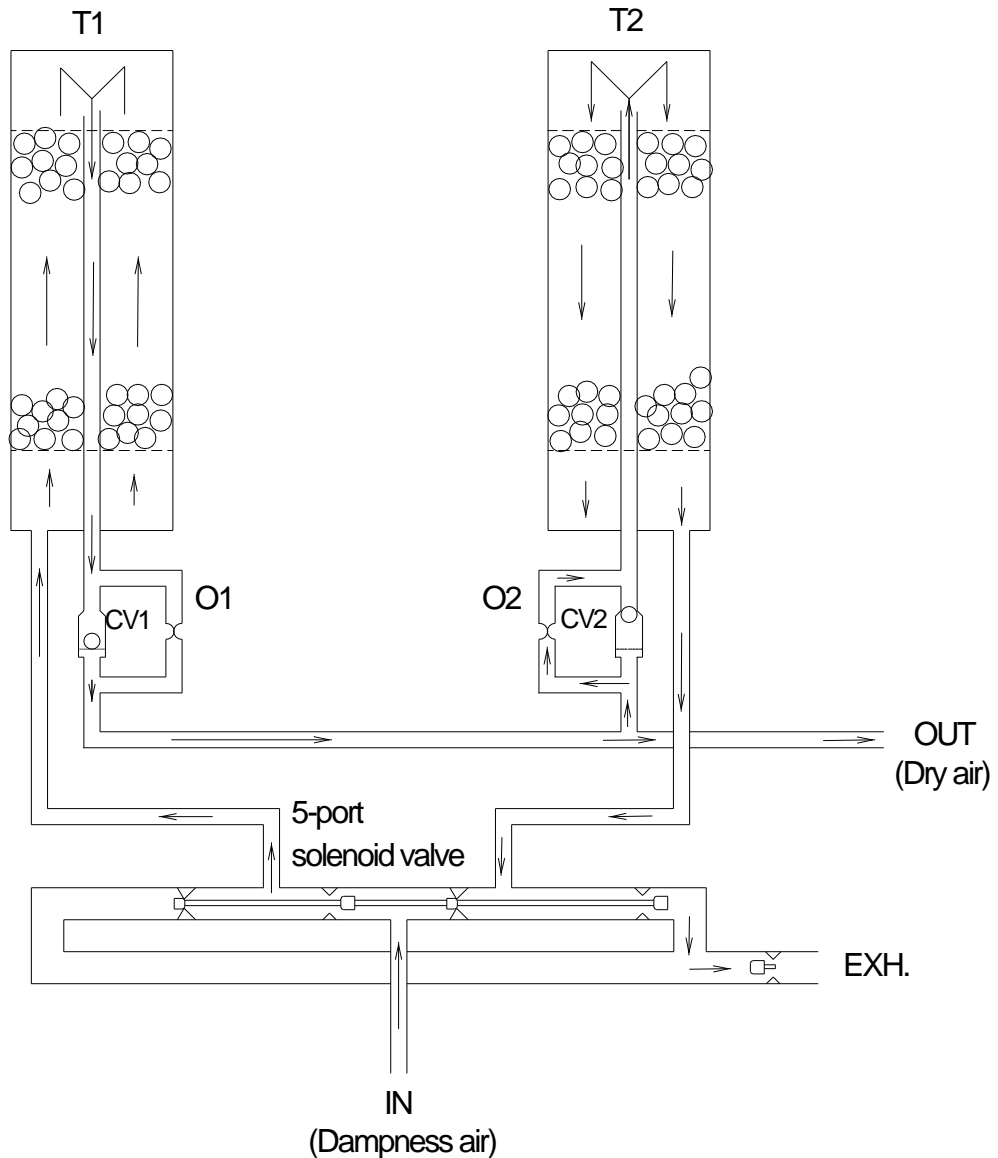

Revision history
Rev D : January.2023

SMC Corporation

4-14-1, Sotokanda, Chiyoda-ku, Tokyo 101-0021 JAPAN

Tel: + 81 3 5207 8249 Fax: +81 3 5298 5362

URL <https://www.smcworld.com>

Note: Specifications are subject to change without prior notice and any obligation on the part of the manufacturer.

© 2022 SMC Corporation All Rights Reserved