



# Operation Manual

Miniature Fitting

PRODUCT NAME

*M Series*

MODEL / Series / Product Number

**SMC Corporation**

# Contents

1. Safety Instructions	3-4
2. Specific Product Precautions	5-10
3. Specifications	11-12
4. Troubleshooting	12
5. Construction	13-14
6. Spare Parts	14
7. Made to Order	14



# Safety Instructions

These safety instructions are intended to prevent hazardous situations and/or equipment damage. These instructions indicate the level of potential hazard with the labels of “Caution,” “Warning” or “Danger.”

They are all important notes for safety and must be followed in addition to International Standards (ISO/IEC)\*1), and other safety regulations.

\*1) ISO 4414: Pneumatic fluid power -- General rules relating to systems.

ISO 4413: Hydraulic fluid power -- General rules relating to systems.

IEC 60204-1: Safety of machinery -- Electrical equipment of machines .(Part 1: General requirements)

ISO 10218: Manipulating industrial robots -Safety.

etc.



## Caution

**Caution** indicates a hazard with a low level of risk which, if not avoided, could result in minor or moderate injury.



## Warning

**Warning** indicates a hazard with a medium level of risk which, if not avoided, could result in death or serious injury.



## Danger

**Danger** indicates a hazard with a high level of risk which, if not avoided, will result in death or serious injury.

## Warning

### **1. The compatibility of the product is the responsibility of the person who designs the equipment or decides its specifications.**

Since the product specified here is used under various operating conditions, its compatibility with specific equipment must be decided by the person who designs the equipment or decides its specifications based on necessary analysis and test results.

The expected performance and safety assurance of the equipment will be the responsibility of the person who has determined its compatibility with the product.

This person should also continuously review all specifications of the product referring to its latest catalog information, with a view to giving due consideration to any possibility of equipment failure when configuring the equipment.

### **2. Only personnel with appropriate training should operate machinery and equipment.**

The product specified here may become unsafe if handled incorrectly.

The assembly, operation and maintenance of machines or equipment including our products must be performed by an operator who is appropriately trained and experienced.

### **3. Do not service or attempt to remove product and machinery/equipment until safety is confirmed.**

1. The inspection and maintenance of machinery/equipment should only be performed after measures to prevent falling or runaway of the driven objects have been confirmed.

2. When the product is to be removed, confirm that the safety measures as mentioned above are implemented and the power from any appropriate source is cut, and read and understand the specific product precautions of all relevant products carefully.

3. Before machinery/equipment is restarted, take measures to prevent unexpected operation and malfunction.

### **4. Contact SMC beforehand and take special consideration of safety measures if the product is to be used in any of the following conditions.**

1. Conditions and environments outside of the given specifications, or use outdoors or in a place exposed to direct sunlight.

2. Installation on equipment in conjunction with atomic energy, railways, air navigation, space, shipping, vehicles, military, medical treatment, combustion and recreation, or equipment in contact with food and beverages, emergency stop circuits, clutch and brake circuits in press applications, safety equipment or other applications unsuitable for the standard specifications described in the product catalog.

3. An application which could have negative effects on people, property, or animals requiring special safety analysis.

4. Use in an interlock circuit, which requires the provision of double interlock for possible failure by using a mechanical protective function, and periodical checks to confirm proper operation.



# Safety Instructions

## Caution

### **1. The product is provided for use in manufacturing industries.**

The product herein described is basically provided for peaceful use in manufacturing industries. If considering using the product in other industries, consult SMC beforehand and exchange specifications or a contract if necessary.

If anything is unclear, contact your nearest sales branch.

## **Limited warranty and Disclaimer/Compliance Requirements**

The product used is subject to the following "Limited warranty and Disclaimer" and "Compliance Requirements".

Read and accept them before using the product.

### **Limited warranty and Disclaimer**

#### **1. The warranty period of the product is 1 year in service or 1.5 years after the product is delivered, whichever is first. 2)**

Also, the product may have specified durability, running distance or replacement parts.

Please

consult your nearest sales branch.

#### **2. For any failure or damage reported within the warranty period which is clearly our responsibility,**

a replacement product or necessary parts will be provided.

This limited warranty applies only to our product independently, and not to any other damage incurred due to the failure of the product.

#### **3. Prior to using SMC products, please read and understand the warranty terms and disclaimers**

noted in the specified catalog for the particular products.

##### **\*2) Vacuum pads are excluded from this 1 year warranty.**

A vacuum pad is a consumable part, so it is warranted for a year after it is delivered.

Also, even within the warranty period, the wear of a product due to the use of the vacuum pad or failure due to the deterioration of rubber material are not covered by the limited warranty.

### **Compliance Requirements**

#### **1. The use of SMC products with production equipment for the manufacture of weapons of mass destruction(WMD) or any other weapon is strictly prohibited.**

#### **2. The exports of SMC products or technology from one country to another are governed by the relevant security laws and regulation of the countries involved in the transaction. Prior to the shipment of a SMC product to another country, assure that all local rules governing that export are known and followed.**

## Caution

### **SMC products are not intended for use as instruments for legal metrology.**

Measurement instruments that SMC manufactures or sells have not been qualified by type approval tests relevant to the metrology (measurement) laws of each country.

Therefore, SMC products cannot be used for business or certification ordained by the metrology (measurement) laws of each country.

## 2. Specific Product Precautions

### Design/Selection

#### Warning

**(1) Confirm the specifications.**

Products presented in this manual are designed only for use in compressed air systems (including vacuum).

Do not operate at pressures, temperatures, etc., beyond the range of specifications, as this can cause damage or malfunction. (Refer to the specifications.)

Please contact SMC when using a fluid other than compressed air (including vacuum).

We do not guarantee against any damage if the product is used outside of the specification range.

**(2) Do not disassemble the product or make any modifications, including additional machining.**

It may cause human injury and/or an accident.

**(3) Check if PTFE can be used in application.**

PTFE powder (Polytetrafluoroethylene resin) is included in the sealant. Confirm that the use of it will not cause any adverse affect on the system.

#### Caution

**(1) Keep the connection part of fittings and tubing from rotating or oscillating movement. Use Rotary One-touch Fittings (KS or KX Series) in these cases.**

The fittings may be damaged if they are used in the above manner.

**(2) The tubing bending radius in the vicinity of the fitting should be at least the minimum bending radius of the tubing.**

If the bending radius is less than the minimum value, fittings may damage, or tubing may crack or be crushed. The minimum bending radius of the FR soft nylon tubing (TRS series), FR double layer tubing (TRB series), antistatic soft nylon tubing (TAS series), polyolefin tubing (TPH series), soft polyolefin tubing (TPS series) is measured as following in accordance with JIS B8381. Tubing deformation ratio at the minimum bending radius is obtained through the following formula, based on tubing diameter and mandrel diameter by winding the same radius mandrel tube.

$$\eta = \left(1 - \frac{L - D}{2d}\right) \times 100$$

**Tube deformation ratio at the minimum bending radius**

Here,  $\eta$ : Deformation ratio (%)  
 d: Tubing diameter (mm)  
 L: Measured length (mm)  
 D: Mandrel diameter (mm)  
 (Twice against the minimum bending radius)  
 Test temperature: 20±5°C  
 Relative humidity: 65±5 (%)

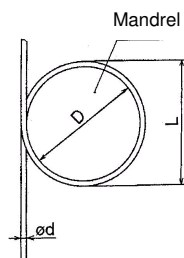

### Design/Selection

**(3) Do not use fluids other than listed on the specifications.**

Applicable fluids are air, N<sub>2</sub> and water. Please consult with SMC if using other fluids.

**(4) When it is used with water, the fittings or tubing may be damaged depending on the surge pressure.**

### Mounting/ Piping

#### Warning

**(1) Operation Manual**

Install the products and operate them only after reading the operation manual carefully and understanding its contents. Also, keep the manual where it can be referred to as necessary.

**(2) Maintenance space**

Allow sufficient space for maintenance and inspection.

**(3) Adhere to the thread tightening method.**

Refer to "Connection Thread Tightening Method" when mounting the product.

**(4) There may be cases of the tubing detaching from the fitting and thrashing around uncontrollably due to tubing degradation or fitting breakage.**

To prevent the situation from becoming uncontrollable, fit the tubing with a protective cover or fix it in place.

#### Caution

**(1) Preparation before piping**

Before piping is connected, it should be thoroughly blown out with air (flushing) or washed to remove chips, cutting oil and other debris from inside the pipe.

**(2) Winding of sealant tape**

When screwing together pipes and fittings, etc., be certain that chips from the pipe threads and sealant do not get inside the pipe. Also, when the sealant tape is used, leave approx. 1 thread ridge exposed at the end of the threads.

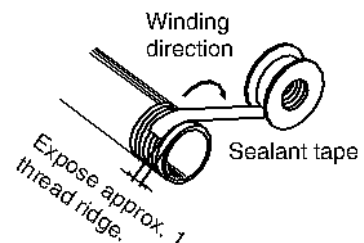

**(3) Check the model, type and size before installation.**

**Also, confirm that there are no scratches, gouges or cracks on the product.**

## Mounting/ Piping



### Caution

- (4) **When connecting the tubing, take pressure or possible changes to the tubing length into account, and allow a sufficient margin.**  
Failure to do so may result in fitting breakage or detachment of the tubing. Refer to the recommended piping conditions.
- (5) **Do not apply unnecessary forces such as twisting, pulling, moment loads, vibration and impact, etc. on fittings or tubing.**  
This will cause damage to the fittings and will crush, burst or release tubing.
- (6) **Tubing, with the exception of coiled tubing, requires stationary installation. Do not use standard tubing (non-coiled) in applications where tubing is required to travel inside the flexible protection tube. Tubing that travels may sustain abrasion, extension, or severance due to tensile force, or may result in removal of tubing from fitting. Use caution prior to use for proper application.**
- (7) **To install the fitting, screw the fitting into the hexagonal face of the body, and tighten with an appropriate wrench.**  
Affix the wrench at the base of the thread. If the size of hexagonal face and wrench do not match, or tightening takes place near the tube side, it may cause collapse or deformation of the hexagonal face, or damage to the equipment. After installing, confirm that there is no damage to the fitting, etc.

## Air Supply



### Warning

- (1) **Type of fluids**  
Please consult with SMC when using the product in applications other than compressed air. Regarding products for general fluids, please contact SMC concerning applicable fluids.
- (2) **When there is a large amount of drainage.**  
Compressed air containing a large amount of drainage can cause malfunction of pneumatic equipment. An air dryer or water separator should be installed upstream from filters.
- (3) **Drain flushing**  
If condensation in the drain bowl is not emptied on a regular basis, the bowl will overflow and allow the condensation to enter the compressed air lines. This causes the malfunction of pneumatic equipment. If the drain bowl is difficult to check and remove, the installation of a drain bowl with an auto drain option is recommended.  
Refer to "SMC Air Preparation System" for further details on compressed air quality.

## Air Supply

- (4) **Use clean air.**

Do not use compressed air that contains chemicals, synthetic oils that include organic solvents, salt, corrosive gases, etc., as they can cause damage or malfunction.



### Caution

- (1) **Install an air filter.**  
Install an air filter at the upstream side of valve. Select an air filter with a filtration degree of 5µm or finer.
- (2) **Install an aftercooler, air dryer or water separator, etc.**  
Compressed air containing a large amount of drainage can cause the malfunction of pneumatic equipment. Therefore, take appropriate measures to ensure air quality, such as by providing an aftercooler, air dryer or water separator.
- (3) **Ensure that the fluid and ambient temperature are within the specified range.**  
If the fluid temperature is 5°C or less, the moisture in the circuit could freeze, causing damage to the seals and leading to equipment malfunction. Therefore, take appropriate measures to prevent freezing. Refer to "SMC Air Preparation System" for further details on compressed air quality.

## Operating Environment



### Warning

- (1) **Do not use in an atmosphere where corrosive gases, chemicals, sea water, water or water steam is present.**  
Refer to each construction drawing on the fittings and tubing material.
- (2) **Do not expose the product to direct sunlight for an extended period of time.**
- (3) **Do not use in a place subject to heavy vibration and/or shock.**
- (4) **Do not mount the product in locations where it is exposed to radiant heat.**
- (5) **Do not use the ordinary fittings and tubing in locations where static electricity would be problematic.**  
It may result in the system failure and trouble. In such places, use of antistatic fittings (KA series) and antistatic tubing (TA series) are recommended.
- (6) **Do not use the ordinary fittings and tubing in locations where spatter is generated.**  
Spattering may result in a fire hazard. In such a place, use of flame resistant fittings (KR/KRM series) and flame resistant tubing (TRS/TRB/TRBU/TRTU series) are recommended.

## Operating Environment

### Warning

- (7) **Do not use in an environment where the product is directly exposed to cutting oil, lubricant or coolant oil, etc.**  
Please contact SMC if using for an environment exposed to cutting oil, lubricant or coolant oil, etc.
- (8) **Take note that if nylon tubing and soft nylon tubing are used in a clean room.**  
The antioxidant on the surface of the soft nylon tubing may come off, thereby lowering the cleanliness level.
- (9) **Do not use in environments where foreign matter may stick to the product or get mixed in the product's interior.**  
This may cause leakage or disconnection of the tubing.

## Maintenance

### Warning

- (1) **Perform maintenance inspection according to the procedures indicated in the operation manual.**  
If handled improperly, malfunction and damage of machinery or equipment may occur.
- (2) **Maintenance work**  
If handled improperly, compressed air can be dangerous. The assembly, handling, repair and element replacement of pneumatic systems should be performed by a knowledgeable and experienced person.
- (3) **Drain flushing**  
Remove drainage from air filters regularly.
- (4) **Removal of equipment and supply/exhaust of compressed air**  
When components are removed, first confirm that measures are in place to prevent workpieces from dropping, run-away equipment, etc. Then, cut off the supply pressure and electric power, and exhaust all compressed air from the system using the residual pressure release function. When the equipment is restarted, proceed with caution after confirming that appropriate measures are in place to prevent cylinders from sudden movement.

### Caution

- (1) **Be certain to wear safety glasses at all times during periodical inspections.**
- (2) **Replace fittings or tubing having the following problems.**
  - a) Cracks, gouges, wearing, corrosion
  - b) Air leakage
  - c) Twists or crushing of tubing
  - d) Hardening, deterioration, softening of tubing
- (3) **When replacing tubes or fittings, do not try to mend or repair and then reuse them.**

## Mounting/Piping of Miniature Fittings

### Piping

### Tubing Connection and Removal

### Caution

#### (1) Applicable tubing size - $\phi 2$

##### a) Connection of tubing

1. Cut the tube perpendicularly allowing additional length. Use tube cutter TK-1, 2, 3, 5 or 6.
2. Insert the tubing into the sleeve.

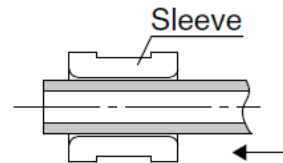

3. Inserting the tubing slowly into the fittings. Make sure to secure a gap of approx. 0.5 mm between the tubing end and the barb end.

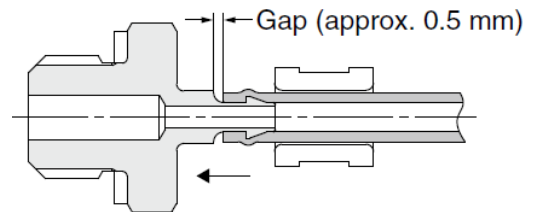

4. Insert the sleeve slowly.

Make sure not to allow any gap between the sleeve end side and the body end side (Please refer to the illustration below). If you feel any strong resistance and cannot push the sleeve completely to the end side, this may be caused due to jamming. Remove and repeat again by starting from step 1 making sure to secure a gap in the step 3.  
Note) When installing the tubing, the sleeve must be attached. Operation without attaching the sleeve may cause tubing disconnection.

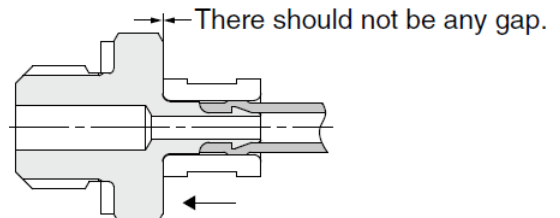

## Install/ removal of tube



### Caution

#### b) Removal of tubing

1. Withdraw the sleeve straight along the tubing. Use a tool such as long-nose pliers if it is difficult to pull out by hand.
2. Withdraw the tubing straight.
3. When reuse the tubing, cut off the previously installed portion of the tubing to avoid possible leakage and/or disconnection of the tubing.

#### (2) Applicable tubing size - $\phi 3.2$ , $\phi 4$ , $\phi 6$

##### Use of Tube with Hose Nipple

##### a) Installation of tubing

1. Cut the tube perpendicularly to the tube axis to a little longer than required length. Use tube cutter TK-1, 2, 3, 5 or 6.
2. Pass the tube through the cap nut.
3. Push the tube until it comes to the end of the hose nipple, or it may cause air leakage or tube releasing.
4. Tighten the cap nut firmly by hand on the fitting.

#### (3) Applicable tubing size - $\phi 3.2$ , $\phi 4$ , $\phi 6$

##### Use of Tube with Barb Fitting

##### a) Installation of tubing

1. Cut the tube perpendicularly to the tube axis to a little longer than required length. Use an SMC tube cutter TK-1, 2, 3, 5 or 6.
2. Push the tube until it comes to the end of the barb portion, or it may cause air leakage or tube releasing.

## Connection Thread Tightening Method



### Caution

#### (1) Tightening of M3/M5 Threads

Tighten by hand, and give it an additional turn with a wrench. Please check the number of tightening revolutions using the table below. If tightened excessively, thread portion may be damaged and gasket may be deformed. This will cause air leakage. On the contrary, if tightened insufficiently, thread may loosen causing air leakage.

Thread	Model	Number of tightening rotations
M3	M-3AU-2	Approx. 1/6 rotations
	M-3AU-□ (Except M-3AU-2)	Approx. 1/4 rotations
	M-3N	
	M-3P	
	M-3ALU-2	Approx. 1/3 rotations
	M-3ALU-□ (Except M-3ALU-2)	Approx. 1/2 rotations
	M-3UL	
M-3UT		
	M-5AU-□	Approx. 1/6 to 1/4 rotations <sup>Note)</sup>
	M-5AN-□	
	M-5H-□	
	M-5J	
	M-5N	
	M-5UN	
	M-5P	
	M-5ALU-□	Approx. 1/2 rotations <sup>Note)</sup>
	M-5ALN-□	
	M-5ALHU-□	
	M-5ALHN-□	
	M-5HL-□	
	M-5HLH-□	
	M-5UL	

Note) As a guideline, the tightening torque should be 1 to 1.5 Nm.

## Tightening tool



### Caution

Use a wrench appropriate for the hexagon flats of the body to tighten the fitting.

Affix the wrench at the base of the thread. If the size of hexagonal face and wrench do not match, or tightening takes place near the tube side, it may cause collapse or deformation of the hexagonal face, or damage to the equipment.

After installing, confirm that there is no damage to the fitting, etc.



## Tightening tool



### Caution

Recommended



No good



Recommended

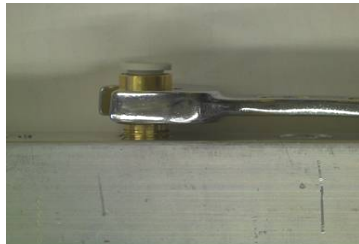

No good



No good

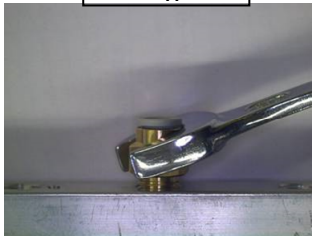

## Chamfer Dimension for Female Thread



### Caution

#### (1) Chamfer dimension for female thread of the connection thread M3 and M5

Confirming to ISO 16030 (air pressure fluid dynamics - connection - ports and stud ends), the chamfer dimensions shown below are recommended.

By chamfering as shown in the following table, machining of threads is easier and effective for burr prevention.

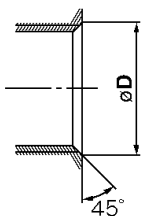

Connection thread size	Chamfer dimension $\phi D$ (Recommended value) [mm]
M3	3.1 to 3.4
M5	5.1 to 5.4

## Recommended Piping Conditions

#### (1) When connecting piping to the fitting, use pipe length with sufficient margin, in accordance with the piping conditions shown in Fig. 1.

Also, when using a tying band, etc., to bind the piping together, make sure that external force does not come to bear on the fitting (See Fig.2).

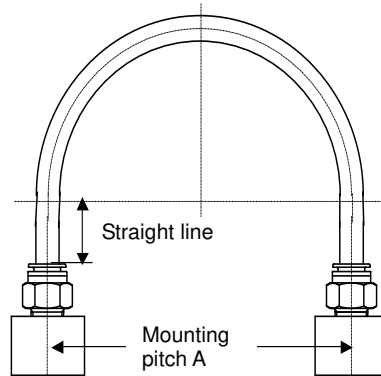

Fig.1 Recommended piping

Unit: mm

Tubing size	Mounting pitch A			Straight line length
	Nylon tubing	Soft nylon tubing	Polyurethane tubing	
$\phi 2$	-	-	13 or more	10 or more
$\phi 3.2$	44 or more	35 or more	25 or more	16 or more
$\phi 4$	56 or more	44 or more	26 or more	20 or more
$\phi 6$	84 or more	66 or more	39 or more	30 or more

## Recommended Piping Conditions



### Caution

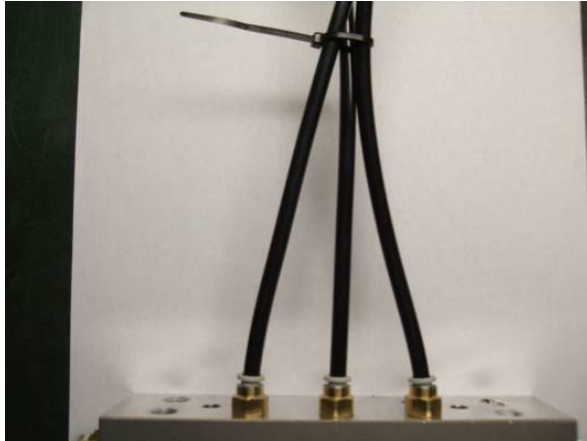

Recommended

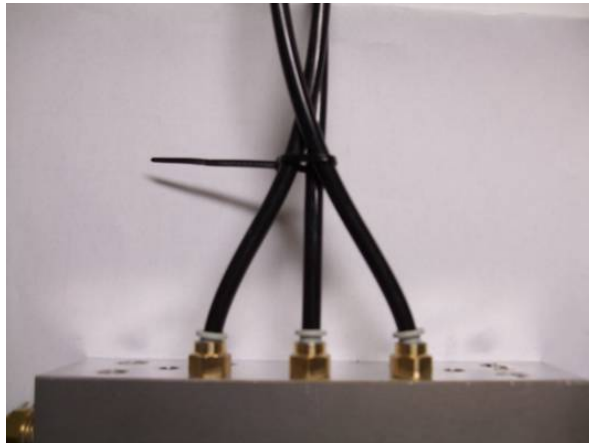

No good

Fig. 2 When using a tying band to bind the piping together

## Tubing

### Design/Selection



### Caution

(1) When using a tubing other than from SMC, be careful of the tolerance of the tubing O.D. and tubing material.

- |                        |                                    |
|------------------------|------------------------------------|
| a) Nylon tubing        | ±Within +/-0.1 mm                  |
| b) Soft nylon tubing   | ±Within +/-0.1 mm                  |
| c) Polyurethane tubing | Within +0.15 mm,<br>Within -0.2 mm |

Do not use the tubing which does not satisfy the specified tubing O.D. accuracy, or if the tubing has a different I.D., material, hardness, or surface roughness from those of SMC's tubing. Please consult with SMC if there is anything unclear. It may cause difficulty in connecting the tubing, leakage, disconnection of the tubing, or fitting damage.

When used with tubing other than those from SMC, due to their properties, the products listed below are not subject to warranty.

ø2M

(2) When using fittings other than those from SMC, be certain to confirm that operating conditions are such that no problems will arise.

### 3. Specifications

#### (1) Applicable tubing size - $\phi 2$

##### Specification

Tubing material	Polyurethane
Fluid	Air, N <sub>2</sub> <sup>Note3)</sup> , water <sup>Note 1) Note2)</sup>
Max. operating pressure <sup>Note 4)</sup>	1 MPa
Ambient and fluid temperature	-5 to 60°C (No freezing) Water: 0 to 40°C (No freezing)

Note 1) The surge pressure must be under the maximum operating pressure.

Note 2) Deionized water is not recommended for use as it may affect the material used in the fittings  
In addition, it is known to degrade the water quality.

Note 3) Barb one-touch fitting is pre-greased. Do not use this product when N<sub>2</sub> is used as clean dry air.

Note 4) Apply the maximum operating pressure to the tubing during the tube connection.

##### Material of main parts

Material	Body	Brass + Electroless nickel plating
	Sleeve	Brass + Electroless nickel plating
	Gasket	Stainless steel S304, NBR

#### (2) Applicable tubing size - $\phi 3.2$ , $\phi 4$ , $\phi 6$

##### Specification

Applicable tubing		Nylon	Soft nylon	Polyurethane	Super PFA <sup>Note1)</sup>	FEP <sup>Note2)</sup>	Modified PTFE <sup>Note3)</sup>
Applicable tubing O.D./I.D.	For M3	-	$\phi 3.18/\phi 2.18$	$\phi 4/\phi 2.5$	$\phi 3.18/\phi 2$ $\phi 4/\phi 2.5$	-	-
	For M5, R1/8	$\phi 4/\phi 2.5$ $\phi 6/\phi 4$		$\phi 4/\phi 2.5$ $\phi 6/\phi 4$	$\phi 3.18/\phi 2$ $\phi 4/\phi 2.5$ $\phi 6/\phi 4$	$\phi 6/\phi 4$	$\phi 4/\phi 2.5$ $\phi 6/\phi 4$
Fluid		Air, N <sub>2</sub> <sup>Note6)</sup> , Water, <sup>Note 4) Note5)</sup>					
Max. operating pressure (at 20°C) <sup>Note 7)</sup>		1.5 MPa	1 MPa	0.8 MPa	1 MPa	1.5 MPa	1.4 MPa
Ambient and fluid temperature		-5 to 60°C (Water: 0 to 40°C) (No freezing)					
Connection size		M3, M5, R1/8			M5, R1/8		

Note 1, 2, 3) Compatible only with hose nipple type.

Note 4) Barb fitting, barb elbow, barb elbow (H) are not compatible with water.

Note 5) Deionized water is not recommended for use as it may affect the material used in the fittings  
In addition, it is known to degrade the water quality.

Note 6) Do not use the universal nipples when N<sub>2</sub> is used as clean dry air because universal nipples are pre-greased.

Note 7) The surge pressure must be under the maximum operating pressure.

Check the operating pressure range of the tubing.

##### Main materials

Material	Body	Brass + Electroless nickel plating (Nipple M-3N, M-5N: Stainless steel 303)
	Gasket	Nylon 66; GF30%, Stainless steel 304; NBR (PVC for M3)

\* Body of M-5E, M-5ER, M-5M is not surface-treated.

Electroless nickel plate treated is available as option -X2.

## Fitting Markings for Applicable Tubing Material (Barb fitting, Barb elbow, Barb elbow (H))

Tubing material determines the compatible fittings. (Refer to the table below.)

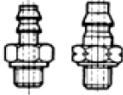
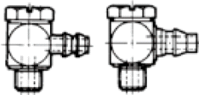
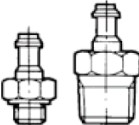
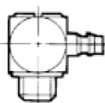
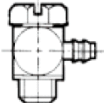
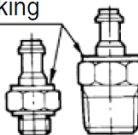
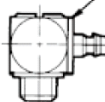
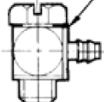
Connection	Tubing	Fitting marking for applicable tubing material		
		Barb fittings	Barb elbow	Barb elbow (H)
M3	Soft nylon tubing Polyurethane tubing		—	
R 1/8, M5	Nylon tubing			
	Soft nylon tubing Polyurethane tubing	Marking 	Marking 	Marking 

## 4. Troubleshooting

M series miniature fitting cannot be disassembled or repaired in order to quality maintenance. When failure such as "Insufficient sealing" occurs, please replace the whole product.

## 5. Construction

Applicable tubing size -  $\phi 2$   
Barb fitting

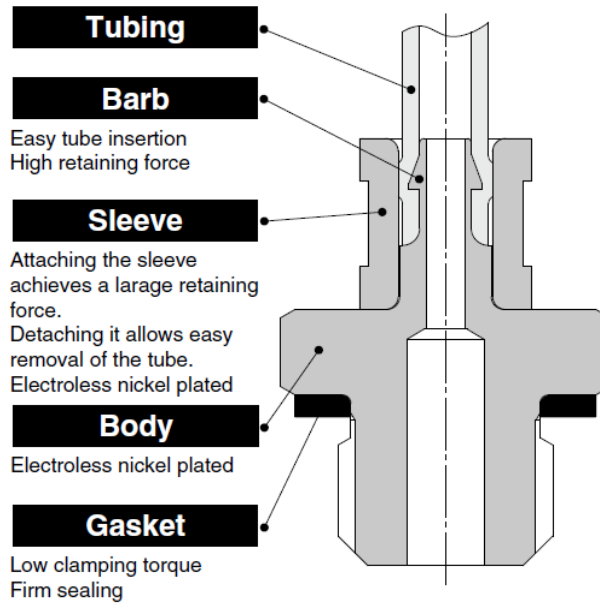

Part name	Material
Sleeve	Brass + Electroless nickel plating
Barb fitting	Brass + Electroless nickel plating
Gasket	NBR, Stainless steel 304

Applicable tubing size -  $\phi 4, \phi 6$   
Hose nipple

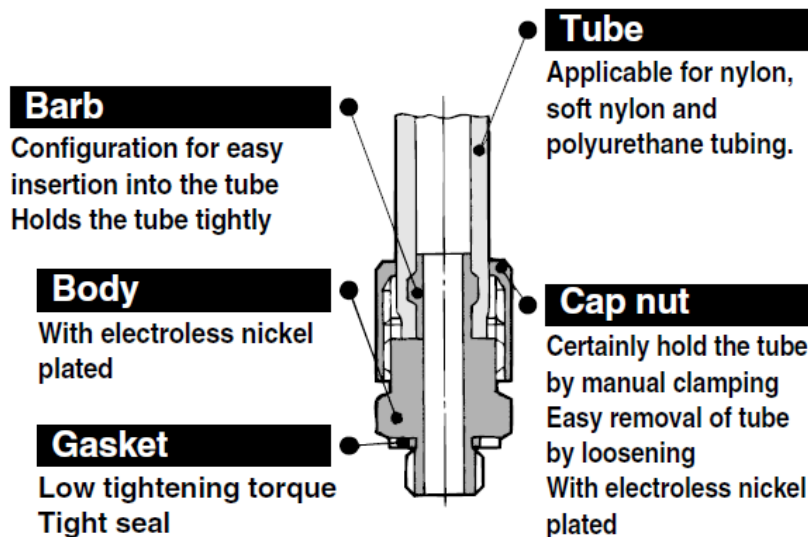

Part name	Material
Body	Brass + Electroless nickel plating
Cap nut	Brass + Electroless nickel plating
Gasket	NBR, Stainless steel 304

Applicable tubing size -  $\phi 3.2$ ,  $\phi 4$ ,  $\phi 6$   
 Barb fitting

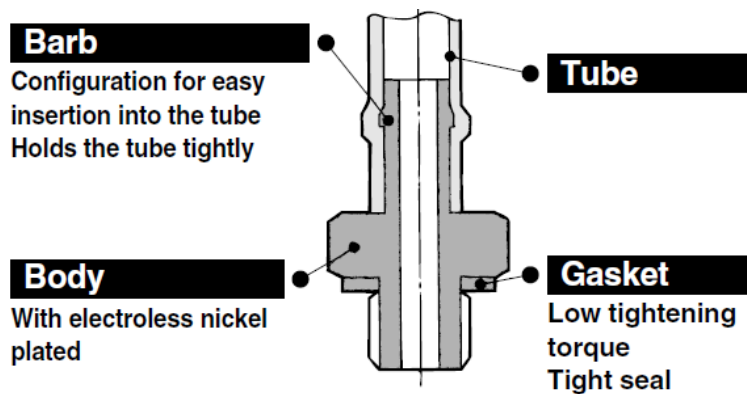

Part name	Material	
Barb fitting.	Brass + Electroless nickel plating	
Gasket	M3	PVC
	M5	NBR, Stainless steel 304

## 6. Spare parts

Part name	Part No.	Applicable thread	Material	Applicable model
Gasket	M-3G	M3	PVC	M-3□-3, 4, 6
	M-3G2		Stainless steel S304, NBR	M-3□-2
	M-5G1	M5	PVC	-
	M-5G2		Stainless steel S304, NBR	M series
	M-5G3		Stainless steel 316, special FKM	-
	M-5GH		Nylon 66, GF30%	M-5AL□-6, M-5ALH□-6 M-5HL-4, 6, M-5HLH-4, 6
Cap nut	M-5-4-P01	-	Brass (Electroless nickel plating)	M-01H-4, M-5H-4 M-5HL-4, M-5HLH-4
	M-5-6-P01	-	Brass (Electroless nickel plating)	M-01H-6, M-5H-6 M-5HL-6, M-5HLH-6

## 7. Made to Order

Please contact SMC for the detailed dimensions, specifications and lead times.

### (1) Gasket material modification

Symbol	Specifications	
X83	Gasket material: Stainless steel 304, NBR	
	Applicable thread	Gasket part No.
	M3 <small>Note 1)</small>	M-3G2
	M5 <small>Note 2)</small>	M-5G2
X226	Gasket material: Stainless steel 304, FKM	
	Applicable thread	Gasket part No.
	M3	M3G-DPH00489
X112	Gasket material: Stainless steel 316, special FKM	
	Applicable thread	Gasket part No.
	M5	M-5G3

Note 1) Compatible with models using M3 excluding M-3□-2.

Note 2) Compatible with only models using M-5GH.

Revision history
B: - Fluid N <sub>2</sub> add Specifications: Note 2,3,5,6) add

## SMC Corporation

4-14-1, Sotokanda, Chiyoda-ku, Tokyo 101-0021 JAPAN  
Tel: + 81 3 5207 8249 Fax: +81 3 5298 5362  
URL <http://www.smcworld.com>

---

Note: Specifications are subject to change without prior notice and any obligation on the part of the manufacturer.  
© 2022 SMC Corporation All Rights Reserved