



# Operation Manual

Product Name

Stainless Steel 316 One-touch Fittings

Model / Series / Product Number

Series KQG2

**SMC Corporation**

# Contents

1. Safety Instructions	2 to 3
2. Specific Product Precautions	4 to 9
3. Specifications	10 to 11
4. Troubleshooting	11
5. Construction	12
6. Chemical Compatibility	13 to 14



# Stainless steel 316 One-touch Fittings

## Safety Instructions

These safety instructions are intended to prevent hazardous situations and/or equipment damage. These instructions indicate the level of potential hazard with the labels of "Caution," "Warning" or "Danger." They are all important notes for safety and must be followed in addition to International Standards (ISO/IEC)\*1), and other safety regulations.

\*1) ISO 4414: Pneumatic fluid power -- General rules relating to systems.

ISO 4413: Hydraulic fluid power -- General rules relating to systems.

IEC 60204-1: Safety of machinery -- Electrical equipment of machines .(Part 1: General requirements)

ISO 10218-1992: Manipulating industrial robots -Safety.

etc.



### Caution

**Caution** indicates a hazard with a low level of risk which, if not avoided, could result in minor or moderate injury.



### Warning

**Warning** indicates a hazard with a medium level of risk which, if not avoided, could result in death or serious injury.



### Danger

**Danger** indicates a hazard with a high level of risk which, if not avoided, will result in death or serious injury.

## Warning

### 1. The compatibility of the product is the responsibility of the person who designs the equipment or decides its specifications.

Since the product specified here is used under various operating conditions, its compatibility with specific equipment must be decided by the person who designs the equipment or decides its specifications based on necessary analysis and test results.

The expected performance and safety assurance of the equipment will be the responsibility of the person who has determined its compatibility with the product.

This person should also continuously review all specifications of the product referring to its latest catalog information, with a view to giving due consideration to any possibility of equipment failure when configuring the equipment.

### 2. Only personnel with appropriate training should operate machinery and equipment.

The product specified here may become unsafe if handled incorrectly.

The assembly, operation and maintenance of machines or equipment including our products must be performed by an operator who is appropriately trained and experienced.

### 3. Do not service or attempt to remove product and machinery/equipment until safety is confirmed.

1. The inspection and maintenance of machinery/equipment should only be performed after measures to prevent falling or runaway of the driven objects have been confirmed.

2. When the product is to be removed, confirm that the safety measures as mentioned above are implemented and the power from any appropriate source is cut, and read and understand the specific product precautions of all relevant products carefully.

3. Before machinery/equipment is restarted, take measures to prevent unexpected operation and malfunction.

### 4. Contact SMC beforehand and take special consideration of safety measures if the product is to be used in any of the following conditions.

1. Conditions and environments outside of the given specifications, or use outdoors or in a place exposed to direct sunlight.

2. Installation on equipment in conjunction with atomic energy, railways, air navigation, space, shipping, vehicles, military, medical treatment, combustion and recreation, or equipment in contact with food and beverages, emergency stop circuits, clutch and brake circuits in press applications, safety equipment or other applications unsuitable for the standard specifications described in the product catalog.

3. An application which could have negative effects on people, property, or animals requiring special safety analysis.

4. Use in an interlock circuit, which requires the provision of double interlock for possible failure by using a mechanical protective function, and periodical checks to confirm proper operation.



# Stainless steel 316 One-touch Fittings

## Safety Instructions

### **Caution**

#### **1. The product is provided for use in manufacturing industries.**

The product herein described is basically provided for peaceful use in manufacturing industries.

If considering using the product in other industries, consult SMC beforehand and exchange specifications or a contract if necessary.

If anything is unclear, contact your nearest sales branch.

### **Limited warranty and Disclaimer/Compliance Requirements**

The product used is subject to the following "Limited warranty and Disclaimer" and "Compliance Requirements".

Read and accept them before using the product.

#### **Limited warranty and Disclaimer**

##### **1. The warranty period of the product is 1 year in service or 1.5 years after the product is delivered, whichever is first.\*2)**

Also, the product may have specified durability, running distance or replacement parts. Please consult your nearest sales branch.

##### **2. For any failure or damage reported within the warranty period which is clearly our responsibility, a replacement product or necessary parts will be provided.**

This limited warranty applies only to our product independently, and not to any other damage incurred due to the failure of the product.

##### **3. Prior to using SMC products, please read and understand the warranty terms and disclaimers noted in the specified catalog for the particular products.**

**\*2) Vacuum pads are excluded from this 1 year warranty.**

A vacuum pad is a consumable part, so it is warranted for a year after it is delivered.

Also, even within the warranty period, the wear of a product due to the use of the vacuum pad or failure due to the deterioration of rubber material are not covered by the limited warranty.

#### **Compliance Requirements**

##### **1. The use of SMC products with production equipment for the manufacture of weapons of mass destruction (WMD) or any other weapon is strictly prohibited.**

##### **2. The exports of SMC products or technology from one country to another are governed by the relevant security laws and regulations of the countries involved in the transaction. Prior to the shipment of a SMC product to another country, assure that all local rules governing that export are known and followed.**

### **Caution**

#### **SMC products are not intended for use as instruments for legal metrology.**

Measurement instruments that SMC manufactures or sells have not been qualified by type approval tests relevant to the metrology (measurement) laws of each country.

Therefore, SMC products cannot be used for business or certification ordained by the metrology (measurement) laws of each country.

## 2. Specific Product Precautions (1)

### Design/Selection

#### Warning

##### (1) Check the specifications.

The products in this catalog are designed to be used in compressed air systems (including vacuum) only.

If the products are used in an environment where pressure or temperature is out of the specified range, damage and/or malfunction may result. Do not use under such conditions. (Refer to the specifications.)

Please consult with SMC when using a fluid other than compressed air (including vacuum).

We do not guarantee against any damage if the product is used outside of the specification range.

##### (2) Do not disassemble the product or make any modifications, including additional machining.

It may cause human injury and/or an accident.

##### (3) Check if PTFE can be used in application.

PTFE powder (Polytetrafluoroethylene resin) is included in the sealant. Confirm that the use of it will not cause any adverse affect on the system.

#### Caution

##### (1) Keep the connection part of fittings and tubing from rotating or oscillating movement. Use Rotary One-touch Fittings (Series KS or KX) in these cases. The fittings may be damaged if they are used in the above manner.

##### (2) The tubing bending radius in the vicinity of the fitting should be at least the minimum bending radius of the tubing.

If the bending radius is less than the min. value, fittings may damage, or tubing may crack or be crushed. The minimum bending radius, with the exception of TS soft nylon tubing, TU polyurethane tubing, TUH hard polyurethane tubing, TUS soft polyurethane tubing, TRBU FR double layer polyurethane tubing, TH FEP tubing, TL PFA tubing, TD modified PTFE tubing, is measured as following in accordance with JIS B 8381-1995. Tubing deformation ratio at the minimum bending radius is obtained through the following formula, based on tubing diameter and mandrel diameter by wrapping the same radius mandrel tube.

$$\eta = \left(1 - \frac{L - D}{2d}\right) \times 100$$

Here,  $\eta$  : Deformation ratio (%)  
 $d$  : Tubing diameter (mm)  
 $L$  : Measured length (mm)  
 $D$  : Mandrel diameter (mm)  
 (Twice against the minimum bending radius)  
 Test temperature: 20 ±5°C  
 Relative humidity: 65 ±5%

Tube deformation ratio at the minimum bending radius

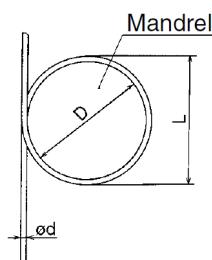

##### (3) Do not use fluids other than listed in the specifications.

Applicable fluids are air, N<sub>2</sub>, water and steam. Please consult with SMC if using other fluids.

##### (4) When it is used with water, the fittings or tubing may be damaged depending on the surge pressure.

##### (5) The surge pressure must be under the maximum operating pressure. If the surge pressure exceeds the maximum operating pressure, it will result in damage to fittings and tubing or the tubing may result in being fallen out.

##### (6) If using a fluororesin tubing in an environment where the fluid temperature changes drastically, it is recommended to use an inner sleeve. Otherwise, air leakage may occur or the tube may release from fitting due to deformation of the tubing.

##### (7) The particle generation of the KQG2 series depends on the operating conditions and operating environment. If you are concerned about the effects on machinery and equipment, check the particle generation with your machine before use.

The components of the KQG2 series may slide due to changes in the internal pressure, which may generate particles. When using male elbow, male branch tee, and extended male elbow fittings, particles may be generated by rotation for positioning after connecting.

### Mounting/Piping

#### Warning

##### (1) Operation manual

Install the products and operate them only after reading the operation manual carefully and understanding its contents. Also, keep the manual where it can be referred to as necessary.

##### (2) Ensure sufficient space for maintenance activities.

When installing the products, allow access for maintenance.

##### (3) Adhere to the thread tightening method.

When installing the products, refer to "Connection Thread Tightening Method".

##### (4) There may be cases of the tubing detaching from the fitting and thrashing around uncontrollably due to tubing degradation or fitting breakage.

To prevent the situation from becoming uncontrollable, fit the tubing with a protective cover or fix it in place.

## 2. Specific Product Precautions (2)

### Mounting/Piping

#### Caution

##### (1) Preparation before piping

Before piping is connected, it should be thoroughly blown out with air (flushing) or washed to remove chips, cutting oil and other debris from inside the pipe.

##### (2) Wrapping of sealant tape

When screwing together pipes and fittings, etc., be certain that chips from the pipe threads and sealant does not get inside the pipe.

Also, when the sealant tape is used, leave approx. 1 thread ridges exposed at the end of the threads.

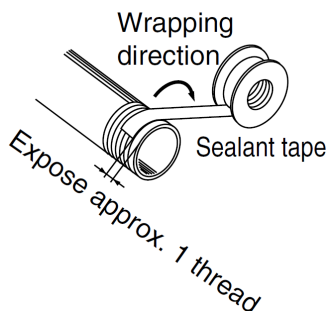

##### (3) Check the model, type and size before installation.

Also, confirm that there are no scratches, gouges or cracks on the product.

##### (4) When connecting the tubing, take pressure or possible changes to the tubing length into account, and allow a sufficient margin.

Failure to do so may result in fitting breakage or detachment of the tubing. Refer to the recommended piping conditions.

##### (5) Do not apply unnecessary forces such as twisting, pulling, moment loads, vibration and impact, etc. on fittings or tubing.

This will cause damage to fittings and will crush, burst or release tubing.

##### (6) Tubing, with the exception of coiled tubing, requires stationary installation. Do not use standard tubing (non-coiled) in applications where tubing is required to travel. Tubing that travels may sustain abrasion, extension, or severance due to tensile force, or may result in removal of tubing from fitting. Use caution prior to use for proper application.

##### (7) To install the fitting, screw the fitting into the hexagonal face of the body, and tighten with an appropriate wrench.

Affix the wrench at the base of the thread. If the size of hexagonal face and wrench do not match, or tightening takes place near the tube side, it may cause collapse or deformation of the hexagonal face, or damage to the equipment. After installing, confirm that there is no damage to the fitting, etc.

##### (8) When performing the piping work, turn the tightening tool in the horizontal direction to the hex. across flats of the stud so that any moment is not applied to the body.

If the tool is in contact with the body, this may cause the stud to come off.

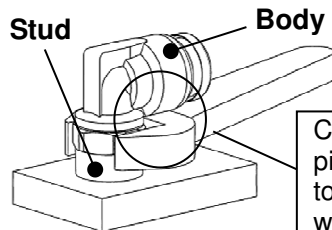

##### (9) The union elbow, union tee, union "Y", different diameter tee and different diameter union "Y" should be fixed through the mounting hole.

Otherwise, air leakage or breaking can occur due to a pulling force or moment load created by the product's weight.

##### (10) The male elbow, male branch tee, and extended male elbow can be turned for positioning after connecting, but they cannot be used while turning them.

Doing so may cause worn out metallic particles to enter the fluid or the fitting to break.

##### (11) If the connection tube oscillates or turns, do not use this product.

Doing so may cause the fitting to break. In particular, for the product with the stud, this may cause the stud to come off.

### Air Supply

#### Warning

##### (1) Type of fluids

Please consult with SMC when using the product in applications other than compressed air.

Regarding products for general fluids, please contact SMC concerning applicable fluids.

##### (2) When there is large amount of drainage.

Compressed air containing a large amount of drainage can cause malfunction of pneumatic equipment. An air dryer or water droplet separator should be installed upstream from filters.

##### (3) Drain flushing

If condensation in the drain bowl is not emptied on a regular basis, the bowl will overflow and allow the condensation to enter the compressed air lines. It causes malfunction of pneumatic equipment. If the drain bowl is difficult to check and remove, installation of a drain bowl with an auto drain option is recommended.

For details on the above compressed air quality, refer to SMC's Best Pneumatics catalog.

##### (4) Use clean air.

Do not use compressed air that contains chemicals, synthetic oils including organic solvents, salt or corrosive gases, etc., as it can cause damage or malfunction.

## 2. Specific Product Precautions (3)

### Air Supply

#### Caution

**(1) Install an air filter.**

Install an air filter at the upstream side of valve. Select an air filter with a filtration degree of 5µm or finer.

**(2) Install an aftercooler, air dryer or water droplet separator, etc.**

Compressed air that contains a large amount of drainage can cause malfunction of pneumatic equipment. Therefore, take appropriate measures to ensure air quality, such as by providing an aftercooler, air dryer, or water droplet separator.

**(3) Ensure that the fluid and ambient temperature are within the specified range.**

If the fluid temperature is 5°C or less, the moisture in the circuit could freeze, causing damage to the seals and leading to equipment malfunction. Therefore, take appropriate measures to prevent freezing.

For details on the above compressed air quality, refer to SMC's Best Pneumatics catalog.

### Operating Environment

#### Warning

**(1) Do not use in an atmosphere having corrosive gases, chemicals, sea water, water, water steam, or where there is direct contact with any of these.**

Refer to each construction drawing on the fittings and tubing material.

**(2) Do not expose the product to direct sunlight for an extended period of time.**

**(3) Do not use in a place subject to heavy vibration and/or shock.**

**(4) Do not mount the product in locations where it is exposed to radiant heat.**

**(5) Do not use the ordinary fittings and tubing in locations where static electricity would be problematic.**

It may result in the system failure and trouble. In such places, use of antistatic fittings (Series KA) and antistatic tubing (Series TA) are recommended.

**(6) Do not use the ordinary fittings and tubing in locations where spatter is generated.**

Spattering may result in a fire hazard. In such a place, use of flame resistant fittings (Series KR/KRM) and flame resistant tubing (Series TRS/TRB) are recommended.

**(7) Do not use in an environment where the product is directly exposed to cutting oil, lubricant, coolant oil, etc.**

Please contact SMC if using for an environment exposed to cutting oil, lubricant or coolant oil, etc.

**(8) Take note that if nylon tubing and soft nylon tubing are used in a clean room.**

The antioxidant on the surface of the soft nylon tubing may come off, thereby lowering the cleanness level.

**(9) Do not use in environment where foreign matter may stick to the product or get mixed in the product's interior.**

This may cause leakage or disconnection of the tubing.

**(10) Avoid installing and using fittings inside a food zone.**

**•Not installable**

Food zone---An environment where food which will be sold as merchandise, directly touches the fitting components.

**•Installable**

Splash zone---An environment where food which will not be sold as merchandise, directly touches the fitting components.

Non-food zone---An environment where there is no contact with food.

### Maintenance

#### Warning

**(1) Perform maintenance inspection according to the procedures indicated in the operation manual.**

If handled improperly malfunction and damage of machinery or equipment may occur.

**(2) Maintenance work**

If handled improperly, compressed air can be dangerous. Assembly, handling, repair and element replacement of pneumatic systems should be performed by a knowledgeable and experienced person.

**(3) Drain flushing**

Remove drainage from air filters regularly.

**(4) Removal of equipment, and supply/exhaust of compressed air**

When components are removed, first confirm that measures are in place to prevent workpieces from dropping, run-away equipment, etc. Then, cut off the supply pressure and electric power, and exhaust all compressed air from the system using the residual pressure release function. When machinery is restarted, proceed with caution after confirming that appropriate measures are in place to prevent cylinders from sudden movement.

#### Caution

**(1) Be certain to wear safety glasses at all times during periodical inspections.**

**(2) Replace fittings or tubing having the following problems.**

- Cracks, gouges, wearing, corrosion
- Air leakage
- Twists or crushing of tubing

**(3) When replacing tubes or fittings, do not try to mend or repair and then reuse them.**

## 2. Specific Product Precautions (4)

### Mounting/Piping of One-touch Fittings

#### **Caution**

##### (1) Installation and removal of tubing for One-touch fittings

###### a) Installation of tubing

1. Cut the tubing perpendicularly, being careful not to damage the outside surface. Use an SMC tube cutter TK-1, 2, 3, 5 or 6. Do not cut the tubing with pliers, nippers, scissors, etc., otherwise, the tubing will be deformed and trouble may result.
2. The outside diameter of the polyurethane tubing swells when internal pressure is applied to it. Therefore, it may be possible that the tubing cannot be re-inserted into the One-touch fitting. Check the tubing outside diameter, and when the accuracy of the outside diameter is +0.15mm or larger, insert into the One-touch fitting again, without cutting the tubing to use it. When the tubing is re-inserted into the One-touch fitting, confirm that the tubing goes through the release button smoothly.
3. Grease is not used for the KQG2 series, therefore a greater insertion force is required when the tube is installed. In particular, polyurethane tubing may fold when inserted due to its softness. Hold the end of the tubing, and insert it all the way in slowly and securely. Refer to dimension "M" in the dimension drawings for guidance on the insertion depth of tube.
4. Grasp the tubing, slowly push it straight (0 to 5°) into the One-touch fitting until it comes to a stop.
5. Pull the tubing back gently to make sure it has a positive seal. Insufficient installation may cause air to leak or the tubing to release.  
As a guide for checking the tubing is not pulled out, refer to the following table.

Tubing size	Tensile force of tubing (N)
φ 3.2, 1/8"	5
φ 4, 5/32"	8
φ 6, 1/4"	12
φ 8, 5/16"	20
φ 10, 3/8"	30
φ 12, 1/2"	35
φ 16	50

###### b) Removal of tubing

1. Push the release button flange evenly and sufficiently to release the tube. Do not push in the tubing before pressing the release button.
2. Pull out the tubing while keeping the release button depressed. If the release button is not held down sufficiently, the tubing cannot be withdrawn.
3. To reuse the tubing, remove the previously lodged portion of the tubing. If the lodged portion is left on without being removed, it may result in air leakage and removal of the tubing difficult.
4. For tubing used at a high temperature or for an extended period of time, there is a possibility that it will not fit into a One-touch fitting again due to an enlarged O.D. Dispose of the tubing and replace it with a new one.

###### (2) Connecting products with metal rods

Products with metal rods (Series KC, Series KQ2, old Series KQ, Series KN, and Series KM, etc.) cannot be connected to series KQG2/Stainless steel 316 One-touch fittings. If connected, the metal rod cannot be retained by the chuck of the One-touch fitting and products with metal rods may project during pressurization, causing serious personal injury or accident.

Even when products with metal rods can be connected to One-touch fittings, do not use any tube, resin plug, or reducer after connection. This may cause releasing.

For details about One-touch fittings that can connect products with metal rods, contact SMC.



## 2. Specific Product Precautions (5)

### Connection Thread Tightening Method

#### Caution

##### (1) Connection thread: M5 and 10-32UNF

First, tighten by hand, then use a wrench appropriate for the hexagon flats of the body to tighten an additional 1/6 to 1/4 turn.

A reference value for the tightening torque is 1 to 1.5 N·m.

Note) Excessive tightening may damage the thread portion or deform the gasket and cause air leakage. Insufficient tightening may loosen the threads, or cause air leakage.

##### (2) Connection thread: R and NPT

First, tighten the fitting by hand, then use a wrench appropriate for the hexagon flats of the body to tighten it a further two or three turns.

For a tightening torque guide, see the table below.

If the fitting is tightened with excessive, this may cause the fitting to break. In particular, for the product with the stud, the stud may come off.

Connection thread size	Tightening torque N·m
NPT、R1/8	3 to 5
NPT、R1/4	8 to 12
NPT、R3/8	15 to 20
NPT、R1/2	20 to 25

**(3) If the fitting is tightened with excessive torque, a large amount of sealant will seep out. Remove the excess sealant.**

**(4) Insufficient tightening may cause seal failure, or loosen the threads.**

##### (5) Reuse

- Normally, fittings with a sealant can be reused 2 to 3 times.
- To prevent air leakage through the sealant, remove any loose sealant stuck to the fitting by blowing air over the threaded portion.
- If the sealant no longer provides effective sealing, wrap sealing tape over the sealant before reusing. Do not use the sealant in any form other than a tape type.

**(6) Once the fitting has been tightened, backing it out to its original position often causes the sealant to become defective. Air leakage will occur.**

### Chamfer Dimension for Female Thread

#### Caution

##### (1) Chamfer dimension for female thread of the connection thread

Confirming to ISO 16030 (air pressure fluid dynamics – connection – ports and stud ends), the chamfer dimensions shown below are recommended. By chamfering as shown in the following table, machining of threads is easier and effective for burr prevention.

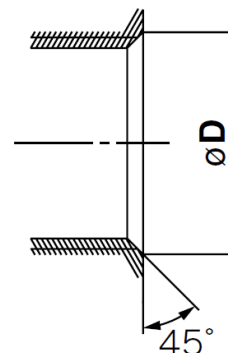

Connection female thread size	Chamfer dimension $\phi D$ (Recommended value) (mm)
M5	5.1~5.4
10-32UNF	5.0~5.3
Rc1/8	10.2~10.4
Rc1/4	13.6~13.8
Rc3/8	17.1~17.3
Rc1/2	21.4~21.6
NPT、NPTF1/8	10.5~10.7
NPT、NPTF1/4	14.1~14.3
NPT、NPTF3/8	17.4~17.6
NPT、NPTF1/2	21.7~21.9

## 2. Specific Product Precautions (6)

### Recommended Piping Conditions

- (1) When connecting piping to the One-touch fitting, use pipe length with sufficient margin, in accordance with the piping conditions shown in Fig. 1.

Also, when using a tying band, etc., to bind the piping together, make sure that external force does not come to bear on the fitting.

(See Fig. 2.)

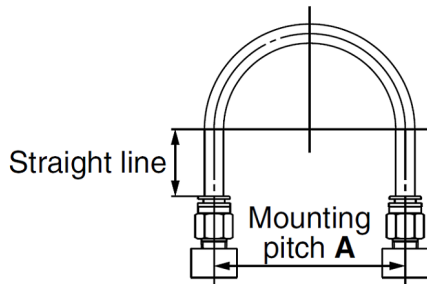

Unit : mm

Tubing size	Mounting pitch A			Straight line length
	Nylon tubing	Soft nylon tubing	Polyurethane tubing	
φ3.2,1/8"	44 or more	35 or more	25 or more	16 or more
φ4,5/32"	56 or more	44 or more	26 or more	20 or more
φ6	84 or more	66 or more	39 or more	30 or more
φ1/4"	89 or more	70 or more	57 or more	32 or more
φ8,5/16"	112 or more	88 or more	52 or more	40 or more
φ10	140 or more	110 or more	69 or more	50 or more
φ3/8"	134 or more	105 or more	69 or more	48 or more
φ12	168 or more	132 or more	88 or more	60 or more
φ1/2"	178 or more	140 or more	93 or more	64 or more
φ16	224 or more	176 or more	114 or more	80 or more

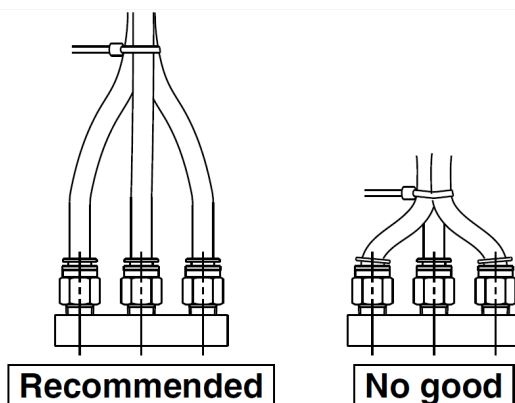

Fig. 2 When using a tying band to bind the piping together

### Precautions for use with non-SMC tubing

#### ⚠ Caution

- (1) When used with tubing other than those from SMC, due to their properties, series KQG2 are not subject to warranty.

### 3. Specifications

#### Applicable Tubing

Tubing material	FEP, PFA, Nylon, Soft nylon, Polyurethane, Polyolefin
Tubing O.D.	φ3.2, φ4, φ6, φ8, φ10, φ12, φ16 φ1/8", φ5/32", φ1/4", φ5/16", φ3/8", φ1/2"

#### Specifications

Fluid	Air, N <sub>2</sub> , Water Note1), Steam Note2),Note3)
Operating pressure range Note4)	-100kPa~1MPa Note5)
Proof pressure	3.0MPa
Ambient and fluid temperature Note6)	-5~150°C (No freezing) Note5)
Lubricant	Grease-free specification
Seal on the threads	With sealant

Note1: The surge pressure must be under the maximum operating pressure.

Note2: Consult with SMC regarding applicable tube separately.

Note3: Using special FKM that is resistant even when steam is used.

Note4: Avoid using in a vacuum holding application such as a leak tester, since there is leakage.

Note5: Check the operating pressure range and operating temperature range of the tubing.

Note6: It is recommended that you use the inner sleeve in the following conditions.

(Except φ3.2 and φ1/8")

- When using in an environment where the fluid temperature changes drastically.
- When using at a high temperature.

#### \* Temperature Condition of Mounting the Inner Sleeve.

Tubing	Temperature
FEP tubing/Series TH	80°C or more
Super PFA tubing/Series TL	120°C or more

#### Cross Reference Table of the Inner Sleeve (Metric size)

Tubing O.D.	Tubing material			Applicable inner sleeve	
	TUS (Soft polyurethane)	TH/THH (FEP)	TL/TIL (Super PFA)	Part no.	Length
φ4	-	TH0402	-	TJG-0402	18
	TUS0425	TH0425	-	TJG-0425	18
	-	-	TL0403	TJG-0403	18
φ6	TUS0604	TH0604	TL0604	TJG-0604	19
φ8	TUS0805	-	-	TJG-0805	20.5
	-	TH0806	TL0806	TJG-0806	20.5
φ10	TUS1065	-	-	TJG-1065	23
	-	TH1075	-	TJG-1075	23
	-	TH1008	TL1008	TJG-1008	23
φ12	TUS1208	-	-	TJG-1208	24
	-	TH1209	-	TJG-1209	24
	-	TH1210	TL1210	TJG-1210	24

\*Stainless steel 316 is used for the TJG series.

### Cross Reference Table of the Inner Sleeve (Inch size)

Tubing O.D.	Tubing material		Applicable inner sleeve	
	TH/TIH (FEP)	TL/TIL (Super PFA)	Part no.	Length
φ5/32"	TH0402	-	TJG-0402	18
	TH0425	-	TJG-0425	18
	-	TL0403	TJG-0403	18
φ1/4"	TIHB07	TIL07	TJG-0604	19
	TIHA07	-	TJG-0746	19
φ5/16"	TH0806	TL0806	TJG-0806	20.5
φ3/8"	TIHB11	TIL11	TJG-1065	23
	TIHA11	-	TJG-1107	23
φ1/2"	TIH13	TIL13	TJG-1395	24

\*Stainless steel 316 is used for the TJG series.

### Spare Parts

Description	Tubing O.D.	Part no.	Material
Gasket	-	M-5G3	Stainless steel 316, Special FKM
Bulkhead nut	φ1/8", φ5/32"	KQG201-P01	Stainless steel 316
	φ3.2, φ4	KQG223-P01	
	φ6	KQG206-P01	
	φ1/4"	KQG207-P01	
	φ8	KQG208-P01	
	φ5/16"	KQG209-P01	
	φ10	KQG210-P01	
	φ3/8"	KQG211-P01	
	φ12	KQG212-P01	
	φ1/2"	KQG213-P01	
φ16	KQG216-P01		

## 4. Troubleshooting

In order to maintain product quality, disassembly or repair of this product is not allowed. Replace the product in the case of failure such as difficulty removing or inserting tubing.

## 5. Construction

Male connector

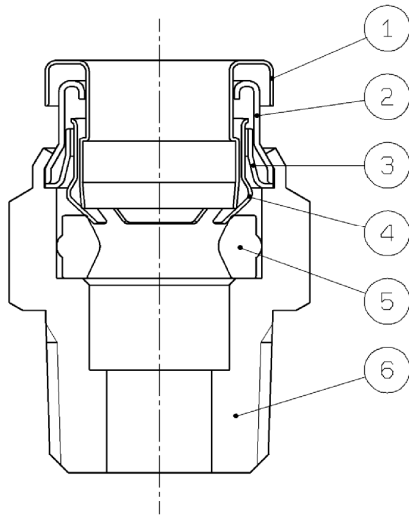

Male elbow

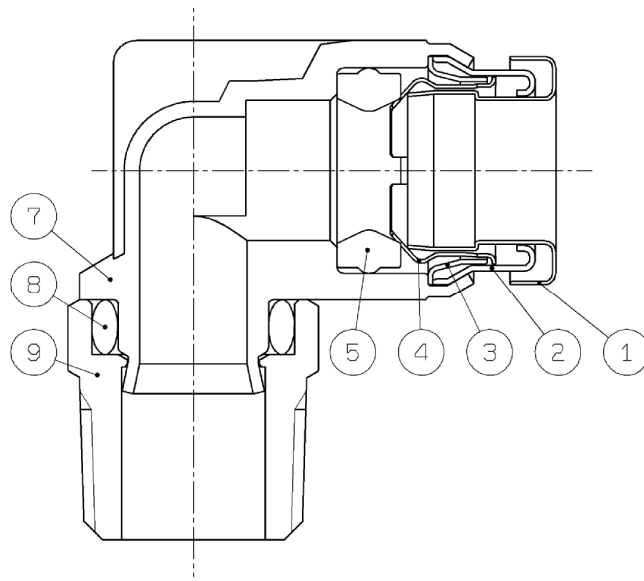

No.	Description	Material
(1)	Release button	Stainless steel 316
(2)	Guide 1	Stainless steel 316
(3)	Guide 2	Stainless steel 316
(4)	Chuck	Stainless steel 316
(5)	Seal	Special FKM (Fluoro coated)
(6)	Male connector body	Stainless steel 316
(7)	Male elbow body	Stainless steel 316
(8)	O-ring	Special FKM (Fluoro coated)
(9)	Stud	Stainless steel 316

### Stainless steel

Metal exists in nature as ore (like oxide or sulfide). This means that oxide or sulfide is more stable than pure metal. Accordingly, metallic material chemically oxidizes (metallic constituent becomes ion and melts out). It corrodes in the natural environment.

Even though corrosion of metal easily occurs in an environment where oxidizing tendency is stronger, some kinds of metal have a characteristic for which corrosion never happens if the level of oxidizing goes higher than a specific point. In such a case, it is called "metal in passive state".

Stainless steel has corrosion resistance because of a thin coat of passive state on its surface. However, there is no stainless steel with an absolute corrosion resistance; therefore, many types of stainless steel have been developed for improved corrosion resistance performance.

## 6. Chemical Compatibility

Compatibility checklist for used materials and fluids

Chemical	Body	Seal
	Stainless steel 316	Special FKM
Acrylonitrile	⊙	×
Acetamide	○	○
Acetaldehyde	⊙	×
Acetone	⊙	×
Aniline	○	⊙
Amylene	⊙	—
Sulphurous acid gas (Humid gas)	⊙	—
Sodium bisulfite [50%]	⊙	—
Allyl alcohol	⊙	—
Benzoic acid	⊙	—
Ammonia (Compressed gas)	⊙	×
Isopropyl alcohol	○	⊙
Isophorone	×	—
Ethyl alcohol	⊙	○
Ethyl ether	○	×
Ethylene	⊙	—
Ethylene glycol	○	⊙
Ethylene diamine	⊙	—
Ethylene dichloride	⊙	—
Epichlorohydrine	⊙	×
Methyl tertiary butyl ether	—	×
Allyl chloride	×	—
Ammonium chloride	⊙	—
Calcium chloride	⊙	—
Iron(II) chloride [5%]	×	—
Sodium chloride	○	—
Magnesium chloride	⊙	—
Hydrochloric acid [5%]	×	—
Chlorine gas (Humid gas)	×	—
Carbitol	×	—
Formic acid [50%]	○	×
o-Xylene	△	△

Chemical	Body	Seal
	Stainless steel 316	Special FKM
p-Xylene	△	△
Citric acid	⊙	—
Cumene	×	—
Glycerin	⊙	⊙
Cresol	⊙	△
Chromic acid [10%]	⊙	—
Chlorosulfonic acid	○	×
Chlorofluorocarbon (CFC) 11	—	×
Chlorofluorocarbon (CFC) 113	—	×
Chlorofluorocarbon (CFC) 12	○	×
Chlorofluorocarbon (CFC) 13B1	—	×
Chlorofluorocarbon (CFC) 14	—	⊙
Chlorofluorocarbon (CFC) 22	○	×
Chlorobenzene	×	○
Chloroform (Trichloromethane)	○	○
Acetic acid	○	×
Amyl acetate	⊙	×
Isopropyl acetate [20%]	⊙	×
Ethyl acetate	×	×
Butyl acetate	×	×
Methyl acetate	⊙	×
Calcium hypochlorite	⊙	—
Sodium hypochlorite [5%]	⊙	⊙
Potassium cyanide [50%]	⊙	—
Copper cyanide	⊙	—
Diisobutyl ketone	⊙	—
Diisobutylene	—	⊙
Diethanolamine	⊙	—
Diethylamine	×	×
Diethylene glycol	⊙	—
Carbon tetrachloride	⊙	⊙
Cyclohexanol	×	—

Note1) [ ] denotes the concentration. Aqueous solutions without condensation notes are in a saturated state.

Note2) The above data is based on a room temperature of 20°C. Note that you may obtain different figures, depending on temperature conditions.

Note3) The above data shows compatibility guidelines based upon component parts. Therefore, it is no guarantee of product performance. In addition, using fluids other than those specified in the catalog are not covered by the product's warranty.

### How to Read the Table

⊙: Completely unaffected or largely unaffected.

○: May be slightly affected, but, dependent upon condition, can sufficiently withstand.

△: Advisable to use as little as possible.

×: Not applicable, as substantially affected.

—: No data is available.

Chemical	Body	Seal
	Stainless steel 316	Special FKM
Cyclohexanone	x	x
Cyclohexane	x	○
Dichloroethylene	—	△
Dichlorobenzene	—	△
Dichloromethane (Methylene chloride)	△	△
Ethylene bromide	x	—
Potassium bromide [30%]	◎	—
Potassium dichromate [25%]	◎	—
Oxalic acid	◎	—
Bromine gas	x	—
Tartaric acid	◎	—
Nitric acid [65%]	◎	◎
Ammonium nitrate	◎	—
Ammonium hydroxide	—	○
Calcium hydroxide	◎	—
Sodium hydroxide [50%]	◎	○
Barium hydroxide	◎	—
Solvent naphtha	◎	—
Carbonic acid (Humid gas and aqueous solution)	◎	—
Tetrachloroethylene	x	◎
Tetrahydrofuran	—	x
Dodecylbenzene	◎	—
Trichloroethane	△	—
Trichloroethylene	◎	○
Trichloroacetic acid	—	—
Toluene	◎	◎
Naphtha	○	○
Naphthenic acid	◎	—
Lactic acid	◎	—
Carbon disulfide	○	◎
Picric acid	◎	—
Pyridine	x	x

Chemical	Body	Seal
	Stainless steel 316	Special FKM
Phenol	x	○
Butyl phthalate	x	—
Butyl alcohol	△	—
Hydrofluoric acid [50%]	◎	—
Furfural	x	x
n-Propyl alcohol	◎	—
Propylene glycol	◎	—
Bromochloroethane	—	x
n-Hexane	○	◎
n-Hexyl alcohol	◎	—
n-Heptane	◎	—
Benzene	x	x
n-Pentane	x	—
Boric acid	◎	—
Gallic acid	◎	—
Formic aldehyde	◎	x
Methyl methacrylate	x	x
Methyl alcohol	◎	○
Methyl isobutyl ketone	x	x
Methyl ethyl ketone	x	x
Ethyleneglycol monomethyl ether	x	—
Monoethanolamine	◎	—
Morpholine	◎	—
Butyric acid	◎	—
Hydrogen sulfide (Humid gas and aqueous solution)	◎	x
Sulphuric acid [10%]	◎	◎
Ammonium sulfate	◎	x
Sodium bisulfate [10%]	◎	—
Iron(II) sulfate	○	—
Sodium sulfate	◎	—
Phosphoric acid [85%]	◎	—

Note1) [ ] denotes the concentration. Aqueous solutions without condensation notes are in a saturated state.

Note2) The above data is based on a room temperature of 20°C. Note that you may obtain different figures, depending on temperature conditions.

Note3) The above data shows compatibility guidelines based upon component parts. Therefore, it is no guarantee of product performance. In addition, using fluids other than those specified in the catalog are not covered by the product's warranty.

#### How to Read the Table

◎: Completely unaffected or largely unaffected.

○: May be slightly affected, but, dependent upon condition, can sufficiently withstand.

△: Advisable to use as little as possible.

x: Not applicable, as substantially affected.

—: No data is available.

#### Revision history

- A: - TK-5 and TK-6 are added.  
- Table of tensile force is added.  
- Caution for removal of tubing is added.  
- Caution for pushing of release button without tubing is removed.  
- Table of recommended piping is revised.
- B: - Compliance Requirements: Caution added  
- Connection thread: R and NPT Changed notation of tightening method.
- C - Fluid N<sub>2</sub> add

## SMC Corporation

4-14-1, Sotokanda, Chiyoda-ku, Tokyo 101-0021 JAPAN  
Tel: + 81 3 5207 8249 Fax: +81 3 5298 5362  
URL <http://www.smcworld.com>

---

Note: Specifications are subject to change without prior notice and any obligation on the part of the manufacturer.  
© 2022 SMC Corporation All Rights Reserved