



Operation Manual

Product Name

Flow Monitor

Model/ Series/ Product Number

LFE0###

SMC Corporation

Contents

Safety Instructions	2
Model Indication and How to Order	9
Summary of Product Parts	10
Definition and Terminology	11
Mounting and Installation	13
Installation	13
Wiring	14
Setting the Detected Flow Rate	17
Function Setting	19
Default Setting	19
F 0 Selection of sensor	21
F 1 Setting of OUT1	22
F 2 Setting of OUT2	30
F 3 Response Time	36
F10 Sub screen display	37
F20 External input	41
F22 Analogue Output in free range	42
F30 Accumulated flow value hold	44
F80 Power saving mode	45
F81 Security Code Request	46
F82 Input of line names	47
F90 Setting of all functions	48
F96 Input value check	49
F97 Selection of copy function	50
F98 Output check	53
F99 Reset to the default settings	54
Other Settings	55
Maintenance and Inspection	58
Troubleshooting	59
Specifications	62
Analogue Output	64
Dimensions	65



Safety Instructions

These safety instructions are intended to prevent hazardous situations and/or equipment damage. These instructions indicate the level of potential hazard with the labels of "Caution," "Warning" or "Danger." They are all important notes for safety and must be followed in addition to International Standards (ISO/IEC)*1), and other safety regulations.

*1) ISO 4414: Pneumatic fluid power -- General rules relating to systems.

ISO 4413: Hydraulic fluid power -- General rules relating to systems.

IEC 60204-1: Safety of machinery -- Electrical equipment of machines .(Part 1: General requirements)

ISO 10218: Manipulating industrial robots -Safety.

etc.



Caution

Caution indicates a hazard with a low level of risk which, if not avoided, could result in minor or moderate injury.



Warning

Warning indicates a hazard with a medium level of risk which, if not avoided, could result in death or serious injury.



Danger

Danger indicates a hazard with a high level of risk which, if not avoided, will result in death or serious injury.

Warning

1. The compatibility of the product is the responsibility of the person who designs the equipment or decides its specifications.

Since the product specified here is used under various operating conditions, its compatibility with specific equipment must be decided by the person who designs the equipment or decides its specifications based on necessary analysis and test results.

The expected performance and safety assurance of the equipment will be the responsibility of the person who has determined its compatibility with the product.

This person should also continuously review all specifications of the product referring to its latest catalog information, with a view to giving due consideration to any possibility of equipment failure when configuring the equipment.

2. Only personnel with appropriate training should operate machinery and equipment.

The product specified here may become unsafe if handled incorrectly.

The assembly, operation and maintenance of machines or equipment including our products must be performed by an operator who is appropriately trained and experienced.

3. Do not service or attempt to remove product and machinery/equipment until safety is confirmed.

1. The inspection and maintenance of machinery/equipment should only be performed after measures to prevent falling or runaway of the driven objects have been confirmed.

2. When the product is to be removed, confirm that the safety measures as mentioned above are implemented and the power from any appropriate source is cut, and read and understand the specific product precautions of all relevant products carefully.

3. Before machinery/equipment is restarted, take measures to prevent unexpected operation and malfunction.

4. Contact SMC beforehand and take special consideration of safety measures if the product is to be used in any of the following conditions.

1. Conditions and environments outside of the given specifications, or use outdoors or in a place exposed to direct sunlight.

2. Installation on equipment in conjunction with atomic energy, railways, air navigation, space, shipping, vehicles, military, medical treatment, combustion and recreation, or equipment in contact with food and beverages, emergency stop circuits, clutch and brake circuits in press applications, safety equipment or other applications unsuitable for the standard specifications described in the product catalog.

3. An application which could have negative effects on people, property, or animals requiring special safety analysis.

4. Use in an interlock circuit, which requires the provision of double interlock for possible failure by using a mechanical protective function, and periodical checks to confirm proper operation.



Safety Instructions

Caution

The product is provided for use in manufacturing industries.

The product herein described is basically provided for peaceful use in manufacturing industries. If considering using the product in other industries, consult SMC beforehand and exchange specifications or a contract if necessary.
If anything is unclear, contact your nearest sales branch.

Limited Warranty and Disclaimer/ Compliance Requirements

The product used is subject to the following "Limited warranty and Disclaimer" and "Compliance Requirements".

Read and accept them before using the product.

Limited Warranty and Disclaimer

1. The warranty period of the product is 1 year in service or 1.5 years after the product is delivered, whichever is first.*2)

Also, the product may have specified durability, running distance or replacement parts. Please consult your nearest sales branch.

2. For any failure or damage reported within the warranty period which is clearly our responsibility, a replacement product or necessary parts will be provided.

This limited warranty applies only to our product independently, and not to any other damage incurred due to the failure of the product.

3. Prior to using SMC products, please read and understand the warranty terms and disclaimers noted in the specified catalog for the particular products.

*2) Vacuum pads are excluded from this 1 year warranty.

A vacuum pad is a consumable part, so it is warranted for a year after it is delivered.

Also, even within the warranty period, the wear of a product due to the use of the vacuum pad or failure due to the deterioration of rubber material are not covered by the limited warranty.

Compliance Requirements

1. The use of SMC products with production equipment for the manufacture of weapons of mass destruction(WMD) or any other weapon is strictly prohibited.

2. The exports of SMC products or technology from one country to another are governed by the relevant security laws and regulation of the countries involved in the transaction. Prior to the shipment of a SMC product to another country, assure that all local rules governing that export are known and followed.

Caution

SMC products are not intended for use as instruments for legal metrology.

Measurement instruments that SMC manufactures or sells have not been qualified by type approval tests relevant to the metrology (measurement) laws of each country.

Therefore, SMC products cannot be used for business or certification ordained by the metrology (measurement) laws of each country.

■ Explanation of Symbols

Symbol	Definition
	Things you must not do. Actual instructions are provided as a drawing or sentence close to this mark.
	Things you must do Actual instructions are provided as a drawing or sentence close to this mark.



■ Operator

<p>(1) This Operation Manual is intended for those who have knowledge of machinery using pneumatic equipment, and have sufficient knowledge of assembly, operation and maintenance of such equipment. Only those persons are allowed to perform assembly, operation and maintenance.</p> <p>(2) Read and understand this Operation Manual carefully before assembling, operating or providing maintenance to the product.</p>

■ Safety Instructions

Warning	
 Disassembly prohibited	Do not disassemble, modify (including the replacement of board) or repair. Otherwise, an injury or failure can result.
 Do not	Do not operate the product outside of the specifications. Do not use for flammable or harmful fluids. Fire, malfunction, or damage to the product can result. Please check the specifications before use.
 Do not	Do not use in an atmosphere containing flammable or explosive gases. Fire or an explosion can result. The product is not designed to be explosion proof.
 Do not	Do not use the product for flammable or highly permeable fluids. Fire, explosion, breakage or corrosion can result.
 Do not	Do not use the product in a place where static electricity is a problem. Otherwise failure or malfunction of the system can result.
 Instruction	If using the product in an interlocking circuit: - Provide a double interlocking system, for example a mechanical system. - Check the product for proper operation. Otherwise malfunction can result, causing an accident.
 Instruction	The following instructions must be followed during maintenance: - Turn off the power supply - Stop supplying fluid before maintenance. It may cause an injury.

⚠ Caution

 Do not touch	Do not touch the terminals and connectors while the power is on. Otherwise electric shock, malfunction or damage to the switch can result.
 Do not touch	Do not touch the piping joint or piping when hot fluid is used. It may lead to burn. Check that the piping is cooled down before touching it.
 Instruction	<ul style="list-style-type: none"> ■ After maintenance is complete, perform appropriate functional inspections and leak test. Stop operation if the equipment does not function properly or there is leakage of fluid. When leakage occurs from parts other than the piping, the product itself may be damaged. Cut off the power supply and stop the fluid supply. Do not apply fluid if the system is leaking. Safety cannot be assured in the case of unexpected malfunction.

■ Handling Precautions

- Follow the instructions given below for selecting and handling.
 - The instructions on design and selection (installation, wiring, environment, adjustment, operation, maintenance, etc.) described below must be followed.
- *Product specifications
 - Use the specified voltage.
 Otherwise failure or malfunction can result.
 Insufficient supply voltage may not drive a load due to a voltage drop inside the product.
 Check the operating voltage of the load before use.
 - Do not exceed the specified maximum allowable load.
 This may cause damage or shorten the lifetime of the product.
 - Data stored by the product is not deleted, even if the power supply is cut off.
 (Write limit: 1000000 cycles, Data duration: 20 years after power off.)
 - Reserve a space for maintenance.
 When designing an application, allow sufficient clearance for maintenance and inspection.

- Product handling

- * Installation

- Tighten to the specified tightening torque.

- If the tightening torque is exceeded, the mounting screws, brackets and product may be damaged. Insufficient torque can cause displacement of the product from its proper position and the looseness of the mounting screws.

- If a commercially available switching power supply is used, be sure to ground the frame ground (FG) terminal.

- Do not use where the product is subjected to vibration or impact.

- Otherwise damage to the internal components may result, causing malfunction.

- Never mount the product in a place that will be used as a scaffold during piping.

- The product may be damaged if excessive force is applied by stepping or climbing onto it.

- * Wiring (Including connecting/disconnecting of the connectors)

- Do not pull the lead wire forcefully, or lift the product by the lead wire (Tensile strength 49 N or less).

- Hold the product body when handling.

- The lead wire will be damaged, leading to failure and malfunction.

- Damage to the connector, cover or internal components may result, causing failure or malfunction.

- Avoid repeatedly bending, stretching or applying a heavy object or force to the lead wire.

- Repetitive bending stress or tensile stress can cause the sheath of the wire to peel off, or breakage of the wire.

- If the lead wire can move, fix it near the body of the product.

- The recommended bend radius of the lead wire is 6 times the outside diameter of the sheath, or 33 times the outside diameter of the insulation material, whichever is larger.

- Replace the damaged lead wire with a new one.

- Wire correctly.

- Incorrect wiring can cause malfunction or damage the product.

- Do not perform wiring while the power is on.

- Otherwise damage to the internal components may result, causing malfunction.

- Do not route wires and cables together with power or high voltage cables.

- Route the wires of the product separately from power or high voltage cables to prevent noise and surge from entering the product.

- Confirm proper insulation of wiring.

- Poor insulation (interference with other circuits, poor insulation between terminals etc.) can apply excessive voltage or current to the product causing damage.

- Design the system to prevent reverse current when the product is performing an operational check.

- Depending on the circuit used, which can cause malfunction and damage to the product.

- Keep wiring as short as possible to prevent interference from electromagnetic noise and surge voltage.

- Do not use a cable longer than 10 m.

- Wire the DC (-) line (blue) as close as possible to the power supply.

- When analogue output is used, install a noise filter (line noise filter, ferrite element, etc.) between the switch-mode power supply and the product.

Operating environment

- Do not use the product in an environment where the product is constantly exposed to water splashes.
Otherwise failure or malfunction can result. Take measures such as using a cover.
- Do not use in an environment where the product could be exposed to corrosive gas or liquids.
Otherwise damage to the internal parts can result, causing malfunction.
- Do not use the product in a place where the product could be splashed by oil or chemicals.
If the product is to be used in an environment containing oils or chemicals such as oily coolant or cleaning solvent, even for a short time, it may be adversely affected (damage, malfunction, or hardening of the lead wires).
- Do not use in an area where surges are generated.
When there are machines or equipment that generate large surges near the product (magnetic type lifter, high frequency inductive furnace, motor, etc.), this can result in deterioration and damage of the internal elements. Take measures against the surge sources, and prevent the lines from coming into close contact.
- Do not use a load which generates surge voltage.
When a surge-generating load such as a relay or solenoid is directly driven, use the product with a surge absorbing element built-in.
- The product is CE marked, but not immune to lightning strikes. Take measures against lightning strikes in the system.
- Mount the product in a location that is not affected by vibration or impact.
Failure or malfunction may result.
- Do not use the product in the presence of a magnetic field.
Malfunction can result.
- Do not let foreign matter, such as wire debris, get inside the product.
Failure or malfunction may result.
- Do not use the product in an environment that is exposed to temperature cycle.
Heat cycles other than ordinary changes in temperature can adversely affect the internal components of the product.
- Do not expose the product to direct sunlight.
If using in a location directly exposed to sunlight, protect the product from the sunlight.
Failure or malfunction may result.
- Keep within the specified operating temperature range.
The operating temperature range is 0 to 50°C.
Avoid abrupt temperature changes even within the specified temperature range.
Failure or malfunction may result.
- Do not use close to a heat source, or in a location exposed to radiant heat.
The heat may cause operation failure.

* Adjustment and Operation

- Check the load status before turning the power supply on.
- Do not short-circuit the load.
 - Although error is displayed when the product load has a short circuit, generated over current may lead to the damage of the product.
- Do not press the setting buttons with a sharp pointed object.
 - This may damage the setting buttons.
- Supply the power when there is no flow.
- The product doesn't produce and output signal for 3 seconds after the power is supplied.
- Perform settings suitable for the operating conditions.
 - Incorrect setting can cause operation failure.
- Before the initial setting and flow setting, be sure to check for the influence on the other components.
 - Stop the control system for setting, if necessary.
- Do not touch the LCD during operation.
 - The display can vary due to static electricity.

* Maintenance

- Confirm safety by turning off the power supply and stopping the flow before performing maintenance.
 - There is a risk of unexpected malfunction.
- Perform regular maintenance and inspections.
 - There is a risk of unexpected failure of components due to the malfunction of equipment and machinery.
- Do not use solvents such as benzene, thinner etc. to clean the product.
 - This may damage the surface of the body or erase the markings on the body.
 - Use a soft cloth to remove stains.
 - For heavy stains, use a cloth soaked with diluted neutral detergent and fully squeezed, then wipe up the stains again with a dry cloth.

Model Indication and How to Order

LFE0 □ □ - □ □ □

Remote type monitor

Output Specifications

Symbol	OUT1	OUT2
A	NPN	NPN
B	PNP	PNP
C	NPN	Analogue 1 to 5V
D	NPN	Analogue 4 to 20mA

Lead wire

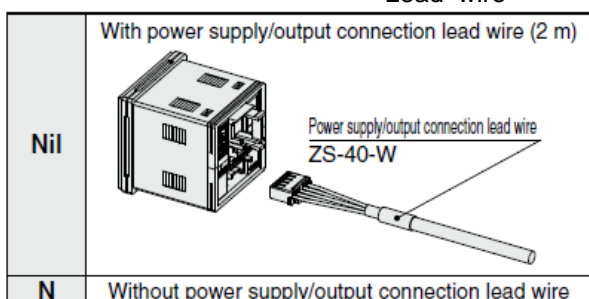

N Without power supply/output connection lead wire

The lead wire is shipped together with the product.

Display unit

Symbol	Instantaneous flow	Accumulated flow
M	L/min	L
G	gal/min	gal

*G: Made to order

Reference: 1[L/min] ↔ 0.2642[gal/min]
1[gal/min] ↔ 3.785[L/min]

Option2(Connector)

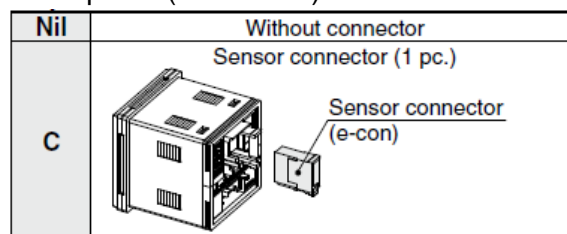

The connector is shipped together with the product.

Option1(Panel type)

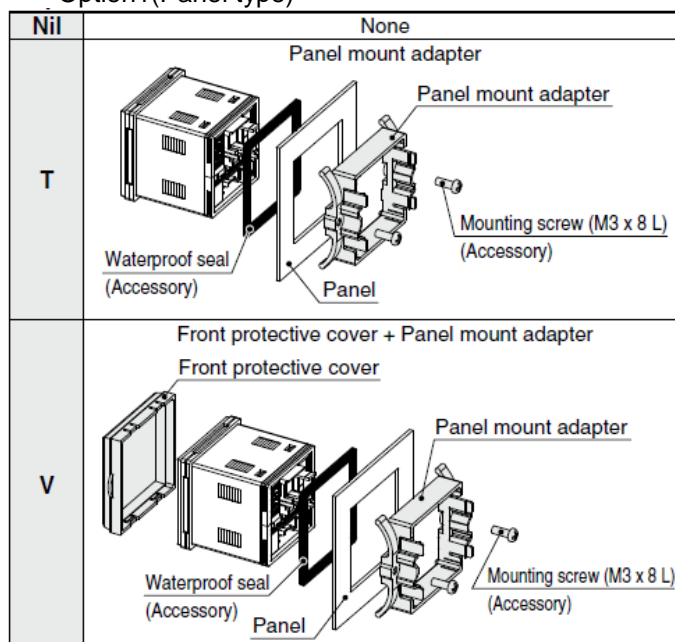

*: When using the remote type, select LFE□□□□(Z) with an analogue output of 1 to 5V.

Does not support the close proximity setting / zero-reset functions.

Accessories/ Part numbers

If an accessory is required, order using the following part number.

Accessories	Part No.	Note
Panel mount adapter	ZS-26-B	Waterproof seal with screw
Front protective cover Panel mount adapter	ZS-26-C	Waterproof seal with screw
Protective cover only	ZS-26-01	Please order panel mount adapters etc. separately
Power supply/output lead wire	ZS-40-W	Lead wire length: 2 m
Sensor connector (e-con)	ZS-28-C-5	1 pcs
Copy lead wire	ZS-40-Y	Connect up to 10 copy destination units

Summary of Product Parts

Front

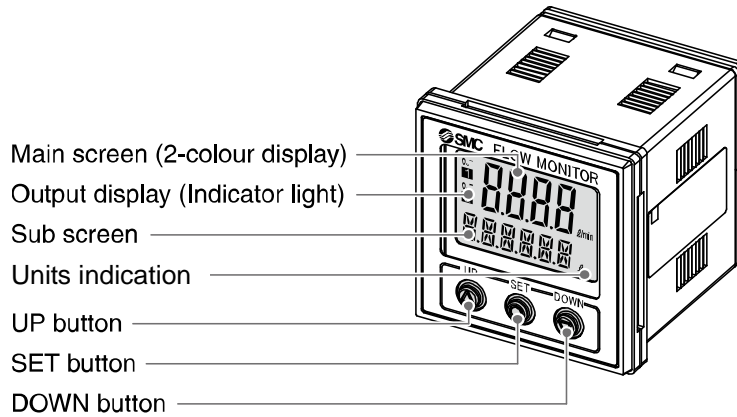

Description	Function
Main screen (2 color display)	Displays the flow value, setting mode and error codes.
Output display (Indicator light)	Displays the output status of OUT1 and OUT2. LED is ON (Orange) when OUT1 is ON.
Sub screen	Displays the accumulated flow, set value, peak/bottom value and more.
Units indication	Indicates the unit currently selected.
UP/DOWN button	Selects the mode and the display shown on the Sub display, or increases /decreases the ON/OFF set value.
SET button	Press this button to change the mode and to set a value.

Back

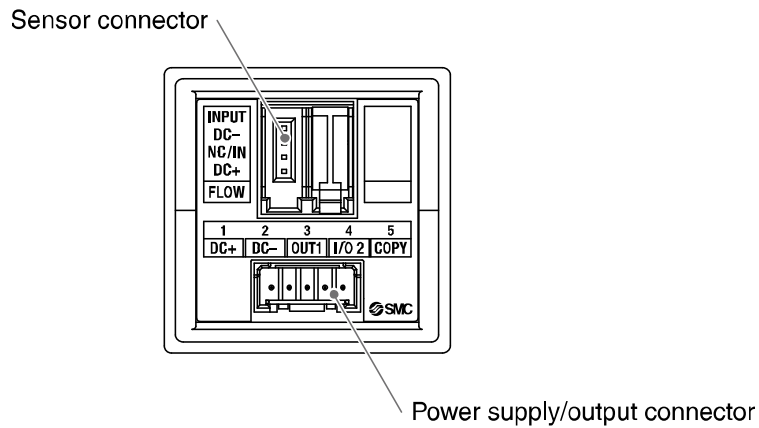

■ Definition and Terminology

	Term	Meaning
A	Accumulated flow	The total amount of fluid that has passed through the device. If an instantaneous flow of 10 L/min lasts for 5 minutes, the accumulated flow will be $10 \times 5=50$ L.
	Accumulated pulse output	A type of output where a pulse is generated every time a predefined accumulated flow passes. It is possible to calculate the total accumulated flow by counting the pulses.
	Accumulated value hold	A function to store the cumulative flow value in the product's internal memory at certain time intervals. The time interval for memory data storage is selectable from 2 or 5 minutes.
	Analogue output	Outputs a value proportional to the flow rate. When the analogue output is in the range 1 to 5V, it will vary between 1 to 5V according to the rate of flow. The same for analogue output of 4 to -20 mA.
C	Chattering	A phenomenon of the switch output turning ON and OFF repeatedly around the set value at high frequency due to the effect of pulsation.
	Copy function	A function to copy flow rate setting values and function settings.
D	Display flow range	The range of flow rates that can be displayed to satisfy the specifications.
F	F.S. (full span / full scale)	This means "full span" or "full scale", and indicates maximum variation width at rated value. For example, when analogue output is 1 to 5 V, $F.S.=5[V] - 1[V]=4[V]$. (Reference: $1\%F.S. = 4[V] \times 1\% = 0.04[V]$)
H	Hysteresis	The difference between ON and OFF points used to prevent chattering.
	Hysteresis mode	Mode where the switch output will turn ON when the flow is greater than the set value, and will turn OFF when the flow falls below the set value by the amount of hysteresis or more.
I	Instantaneous flow	The flow passing per unit of time. If it is 10 L/min, there is a flow of 10 L passing through the device in 1 minute.
	Internal voltage drop	Voltage reduction across an internal device when the switch output is in the ON condition.
K	Key-lock function	Function that prevents changes to the settings of the product (disables button operation).
M	Minimum setting unit	The resolution of set and display values. If the minimum setting unit is 1 L/min, the display will change in 1 L/min steps, e.g. 10.....11.....12 L/min.
O	Operating fluid temperature	Range of fluid temperature that can be used by the product.
	Operating temperature range	Ambient temperature range in which the product can operate.

	Term	Meaning
P	Power saving mode	Number display is turned off to reduce power consumption.
R	Repeatability	Reproducibility of the display or analogue output value, when the measured quantity is repeatedly increased and decreased.
	Response time	The delay time until the set value reaches 63% in relation to the step input.
S	Set point range	The range of ON/OFF threshold values that can be set for those products with a switch output.
	Switch output	Output type that has only 2 conditions, ON or OFF. In the ON condition any connected load will be powered. In the OFF condition, there will be no power supplied to the load. An output showing such behavior is called switch output.
T	Temperature characteristics	Indicates the change in the display value and analogue output caused by ambient temperature or fluid temperature changes.
W	Water hammer	Water hammer or impact pressure is a pressure surge due to pressure spread when a fluid in motion is forced to stop or change direction when equipment such as valve, is opened/closed.
	Window comparator mode	An operating mode in which the switch output is turned on and off depending on whether the flow is inside or outside the range of two set values

Mounting and Installation

■ Installation

Mounting by panel mount adapter

Fix the panel mount adapter to the controller by the mounting screws M3 x 8L (2 pcs.).

Panel mount adapter (Part number: ZS-26-B)

Front protective cover (Part number: ZS-26-01)

Front protective cover
(Part number: ZS-26-01)

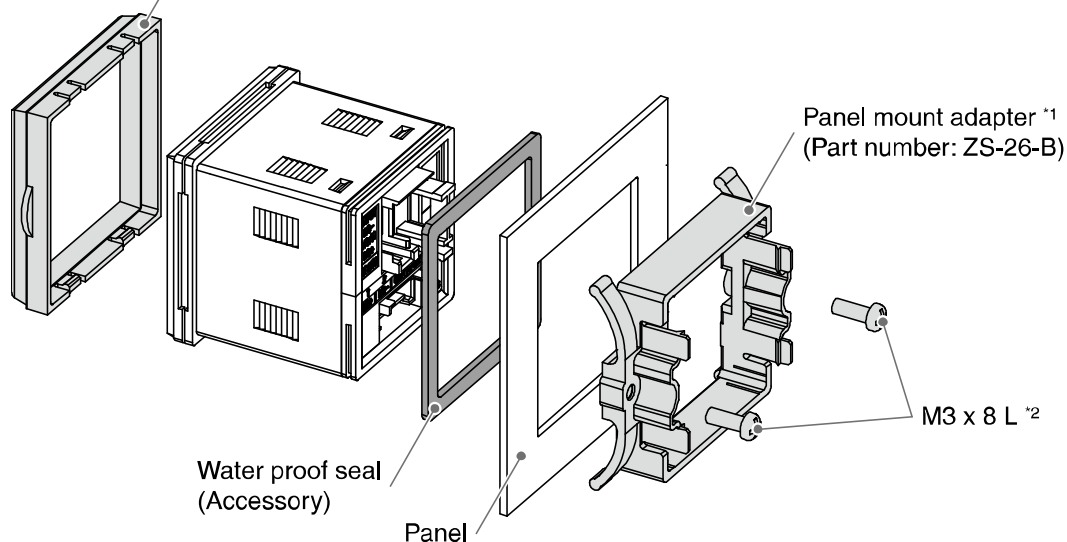

*1: The panel mount adapter can be rotated through 90 degrees for mounting.

*2: The panel mount adapter should be fixed firmly with screws. Otherwise, fluids such as water may enter. After the product makes contact with the panel, the screws should be further tightened 1/4 to 1/2 turn.

Cut-out dimensions for panel mounting

*: See page 66 for panel cut-out dimensions.

How to remove the panel mount adapter

The product with panel mount adapter can be removed from the panel after removing the two screws, and by disconnecting the hooks on both sides.

This can be done by inserting a suitable piece of thin card (as shown in the figure).

Pull the panel mount adapter to the front, and remove the flow monitor.

If the panel mount adapter is pulled forward with the hook caught, the product and the adapter may be damaged.

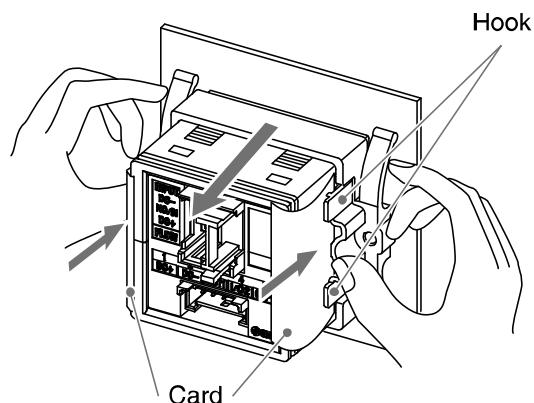

■ Wiring

Connecting and disconnecting of the sensor connector and power supply/output connector

When connecting, insert the connectors straight into the body until it clicks.

· When removing the connector, press down the lever to release the hook from the housing and pull the connector straight out.

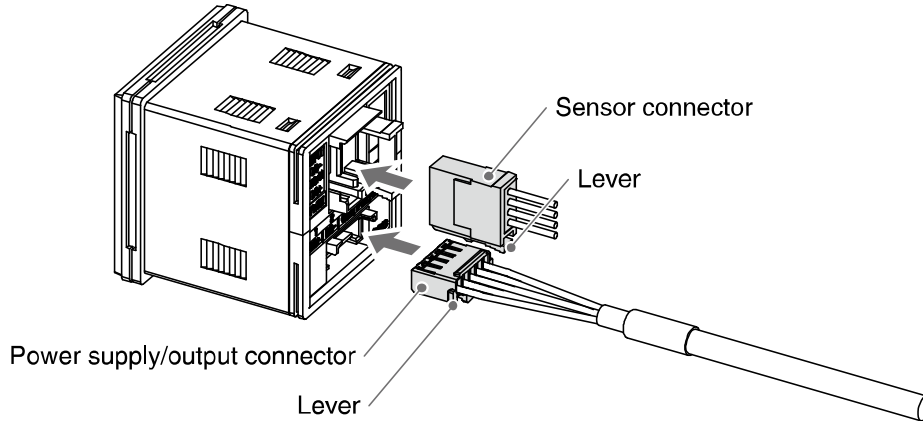

Sensor connector

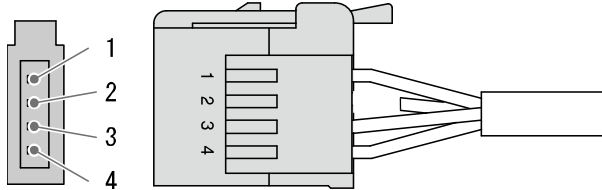

1	DC (+): Brown
2	N.C.: Unused Do not connect to Black.
3	DC (-): Blue
4	INPUT : White (flow sensor 1 to 5 V)

Power supply / output connector

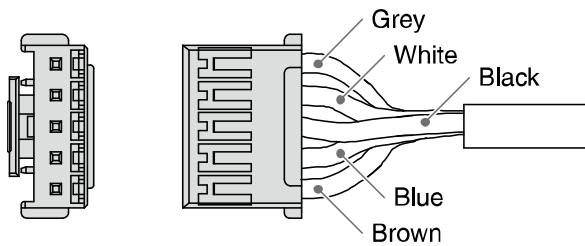

COPY: Grey
OUT2: White
OUT1: Black
DC (-): Blue
DC (+): Brown

Wiring of connector

Attaching/detaching of the connector should be done while the power supply is turned off.

Power lines and high-voltage lines can cause noise. Keep the wiring away from them.

Otherwise, malfunction may result due to noise.

Ensure that the FG terminal is connected to ground when using a commercially available switch-mode power supply.

If you have problems with the switch-mode power supply, consider using a noise filter.

Connection of the sensor lead wire and connector

•Strip the sensor lead wire as shown in the figure on the right.

(Refer to the following table for the connector and applicable wire size.)

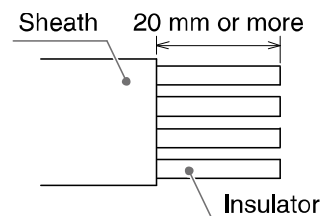

Applicable wire

SMC product No. (1 pcs.)	Colour of cover	Insulator outside diameter
ZS-28-C-5 (Included in the product)	Grey	ø 1.6~ø 2.0

- Do not cut the insulator.
- The core of the corresponding colour shown in the table below is put into the pin of the number stamped on the connector for sensor connection to the back.

Number stamped on connector	Lead wire core colour *
1	Brown
2	Not used
3	Blue
4	White

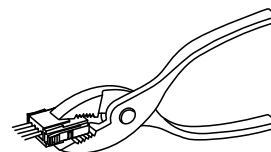
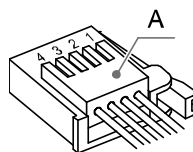

*: When using the lead wire with M12 connector included with the LFE series.

- It checks that the above-mentioned preparation work has been performed correctly, and "A" part shown in the left figure is pushed by hand and makes temporary connection.
- "A" part's center is straightly pushed in by tools, such as pliers.
- The connector for sensor cannot be reused once crimped.
- For the connection failure such as incorrect order of wire and incomplete insertion, please use the new connector for sensor connection.
- When the sensor is not connected correctly, "LLL" can be displayed.

Internal Circuit and Wiring examples

NPN 2 output type
LFE0A

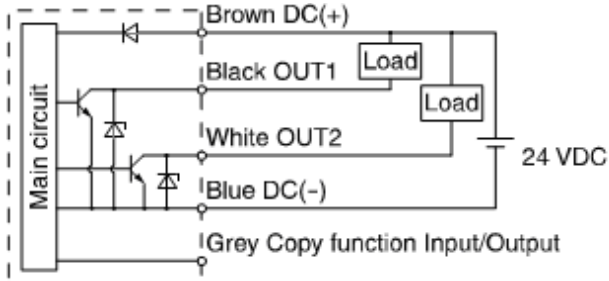

Max.28 V, 80 mA
Internal voltage drop 1 V max.

PNP 2 output type
LFE0B

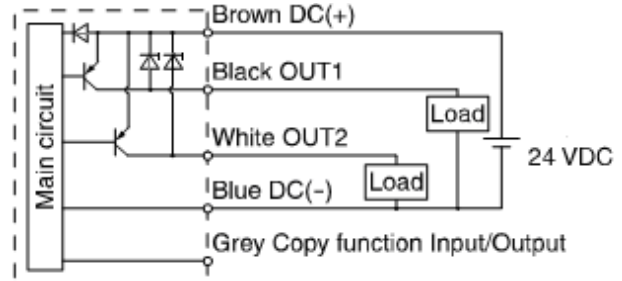

Max.80 mA
Internal voltage drop 1.5 V max.

NPN + Analogue voltage output type
LFE0C

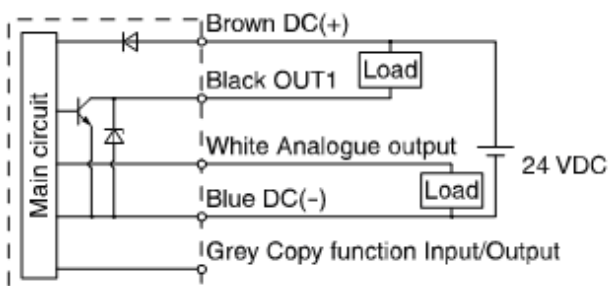

Max.28 V, 80 mA
Internal voltage drop 1 V max.
Analogue output 1 to 5 V
Output impedance 1k Ω

NPN + Analogue current output type
LFE0D

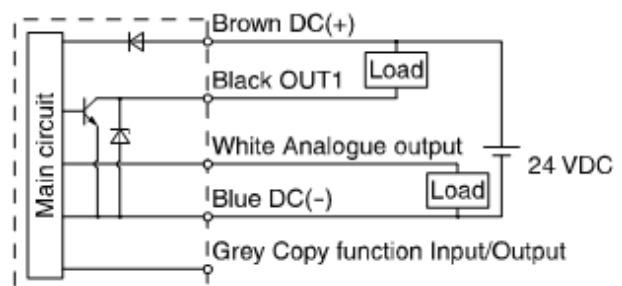

Max.28 V, 80 mA
Internal voltage drop 1 V max.
Analogue output 4 to 20mA
Load impedance 50 to 600 Ω

Precautions before use of the accumulated pulse output

1) The minimum pulse width is set to 50 ms when the accumulated pulse output has been selected.

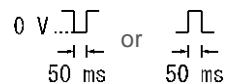

2) When accumulated pulse output is selected, the indicator light will be turned OFF.

Setting the Detected Flow Rate

Measurement mode

Measurement mode is the condition where the flow is detected and displayed, and the switch function is operating.

This basic mode is the beginning from which you can proceed with changing the setting or setting other functions.

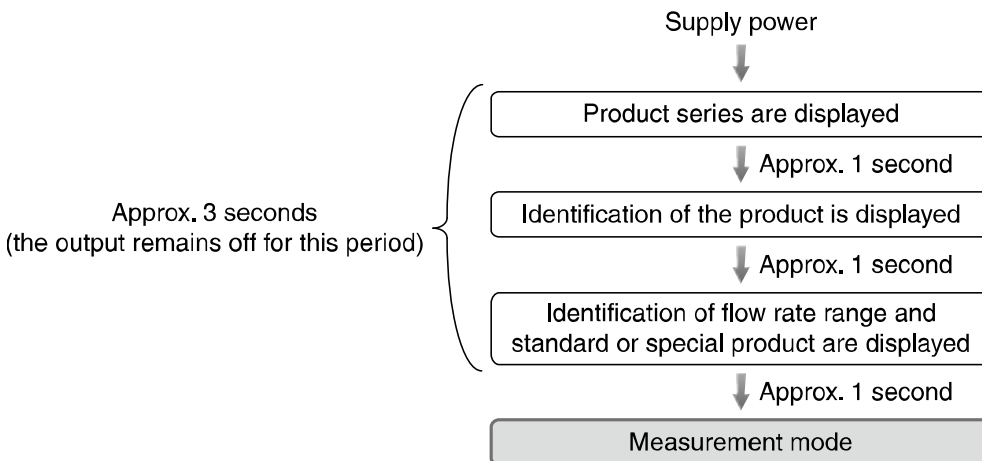

Be sure to select the correct sensor to be connected. (Page 21)

Detected flow rate and switch operation (hysteresis mode)

Set ON and OFF points of the switch output.

When the flow exceeds the set value (P_1), the switch will be turned on.

When the flow falls below the set value (P_1) by the amount of hysteresis (H_1) or more, the switch will be turned off.

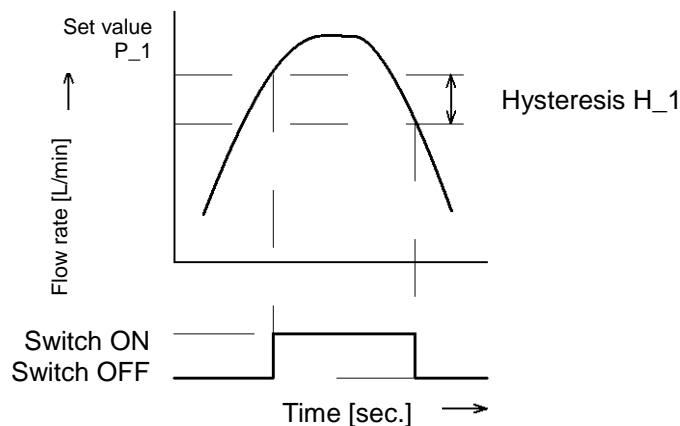



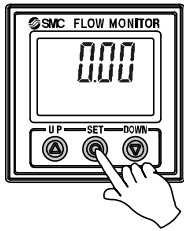

<Simple setting>

(1) Press the  button once in measurement mode.

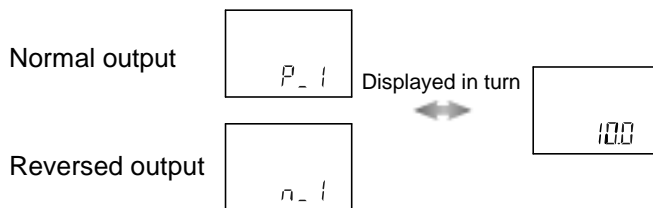



[P_1] or [n_1] and the set value are displayed alternately.



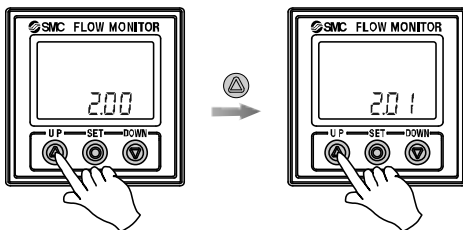

(2) Press the  or  button to change the set value (P_1/n_1).
The  button is to increase and the  button is to decrease the set value.

- Press the  button once to increase the value by one digit, press and hold to continuously increase.

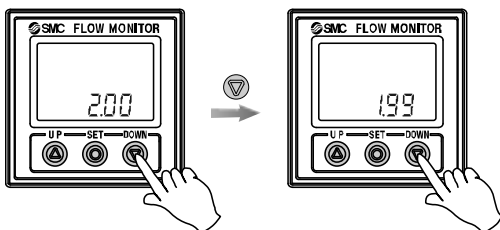

- Press the  button once to reduce the value by one digit, press and hold to continuously reduce.



(3) Press the  button to completed the setting.

The Flow switch turns on within a set flow range (from P1L to P1H) during window comparator mode. Set P1L, the lower limit of the switch operation, and P1H, the upper limit of the switch operation, following the instructions given above. (When reversed output is selected, the main screen displays [n1L] and [n1H].)

When 2 output specification(LFE0A/LFE0B) is used, [P_2] or [n_2] is displayed. Continue with setting the parameter.

(When reversed output is selected, the main screen displays [n_2]).

*: If a button operation is not performed for 30 seconds during the change of setting, the set value will start flashing.

Function Setting



Function selection mode

In measurement mode, press the  button for 2 seconds or longer to display [F 0] on the main screen. In this mode, you can change the function settings. Display the function number [F□□].

Press and hold the  button for 2 seconds or longer in the function selection mode to return to measurement mode.

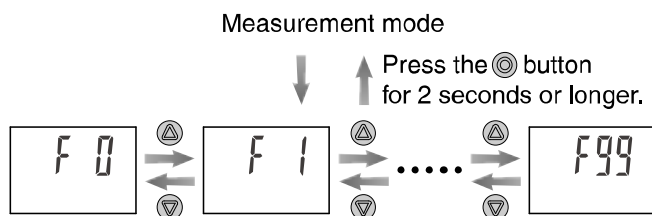
*: The sub screen displays the content of the function and the function setting in turn.



The function number is increased and decreased by the  and  button. Display the required function number and press the  button.

■ Default Setting

The default settings are as follows.

If these settings are acceptable, retain for use.

To change a setting, enter function selection mode (Refer to the table below).

■ [F 0] Selection of sensor ➡ See page 21

Item	Description	Default setting
Range selection of the sensor to be connected	The flow rate range of the sensor to be connected is set.	Rated flow rate 20 L/min type

■ [F 1] Setting of OUT1 ➡ Page 22

Item	Description	Default setting
Output mode	Selects the switch output type from: Instantaneous flow (either hysteresis or window comparator mode), accumulated flow, accumulated pulse.	Hysteresis mode
Reverse output	Selects which type of switch output is to be used, normal or reversed.	Normal output
Set value	Sets the ON and OFF point of the switch output	50% of rated flow
Hysteresis	Appropriate setting of the hysteresis prevents the switch output from chattering.	5% of rated flow
Display color	Select the color of the main screen.	Output ON: Green Output OFF: Red

■ [F 2] Setting of OUT2 ➡ Page 30

Item	Description	Default setting
Output mode	Selects the switch output type from: Instantaneous flow (either hysteresis or window comparator mode), accumulated flow, accumulated pulse.	Hysteresis mode
Reverse output	Selects which type of switch output is to be used, normal or reversed.	Normal output
Set value	Sets the ON and OFF point of the switch output	50% of rated flow
Hysteresis	Setting of hysteresis can prevent chattering.	5% of rated flow

*: Display color is linked to the setting of OUT1, and can not be selected.

Other parameter setting

Item	Page	Default setting
[F 3] Response time	Page 36	1 sec.
[F10] Sub screen	Page 37	Display of set value
[F20] External input	Page 41	-
[F22] Analogue output	Page 42	Free range analogue output for instantaneous flow: OFF
[F30] Accumulated flow value hold	Page 44	OFF[Accumulated value is not held]
[F80] Power saving mode	Page 45	OFF (display is turned on)
[F81] Setting of security code	Page 46	OFF
[F82] Input of line name	Page 47	Blank
[F90] Setting of all functions	Page 48	OFF
[F96] Input value check	Page 49	Display of input voltage (sensor output voltage)
[F97] Selection of copy function	Page 50	OFF
[F98] Output check	Page 53	OFF
[F99] Reset to the default settings	Page 54	OFF
Other settings	Page 55	The key lock has not been set.

Sub screen

In measurement mode, the display of the sub screen can be temporarily changed by pressing the Δ or ∇ buttons.

*: After 30 seconds, it will automatically reset to the display selected in [F10].

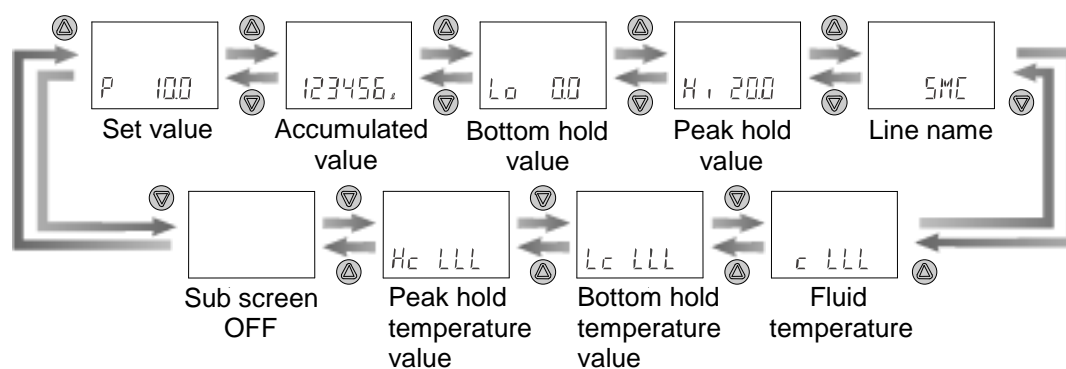

Example for 20 L/min type the above.

The set values of OUT2 and accumulated output cannot be displayed.

* Peak/Bottom hold temperature value and Fluid temperature display are items which are not used for this product.

■ [F 0] Selection of sensor

Select the connected sensor before use.

In measurement mode, when the  button is pressed for 2 seconds or longer, [F 0] is displayed.



➔ The sub screen displays [RANGE] and the currently selected flow rate alternately.

↓ Press the  button.



↓ Sub screen

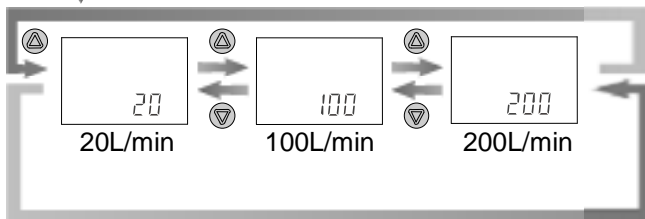

Press the  or  button to select the sensor to be connected.

Press the  button to confirm. ↓ Return to function selection mode.

[F 0] Sensor selection is completed.

■ [F 1] Setting of OUT1

Set the output mode of OUT1.

<Function setting Flowchart>

1. Selection of output mode

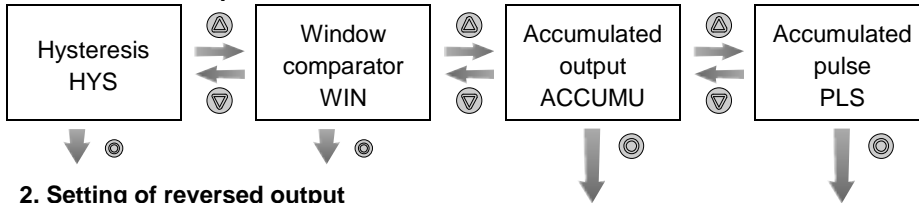

2. Setting of reversed output

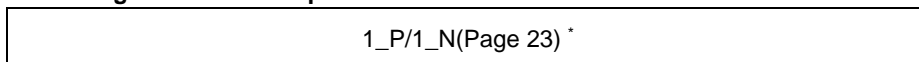

3. Input of set values

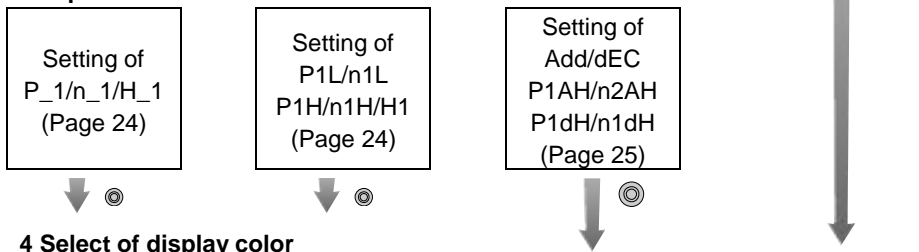

4 Select of display color

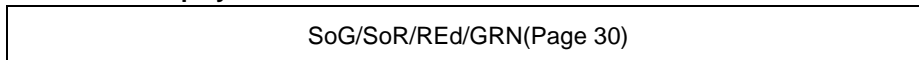

5. Completed

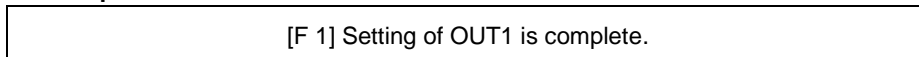

*: By switching to reversed output, the display color will change in relation to the setting.

<Operation>

1. Selection of output mode

Press the or button in function selection mode to display [F 1] on the main screen.

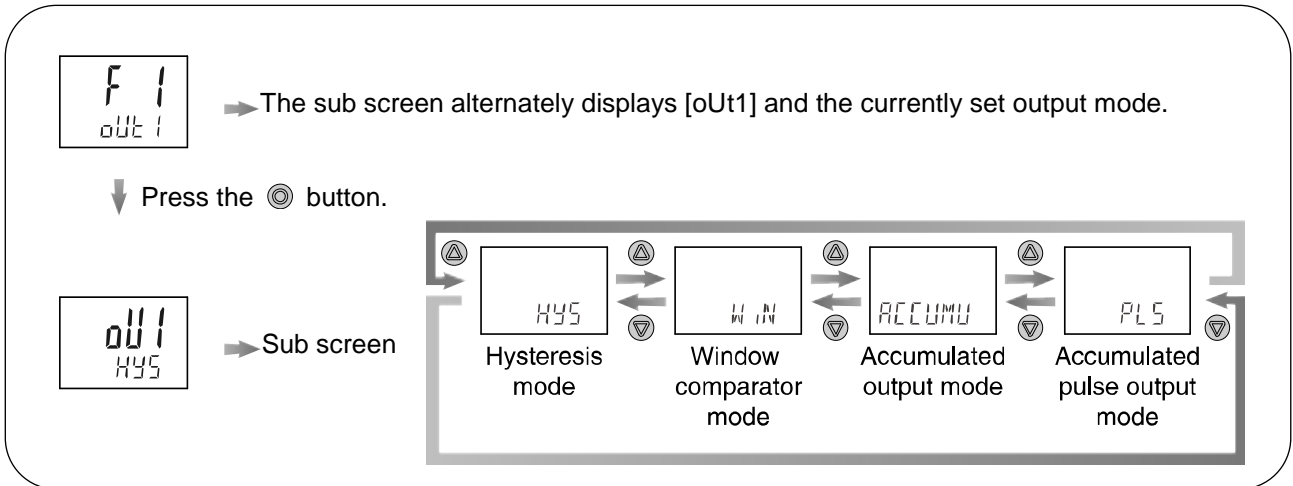

Press the or button to select the desired output mode.

Press the button to set. Move on to the setting of reversed output.

*: If a button operation is not performed for 30 seconds during the change of setting, the display will flash.

*: When the accumulated pulse output is selected, the indicator light will turn off.

2. Setting of reversed output

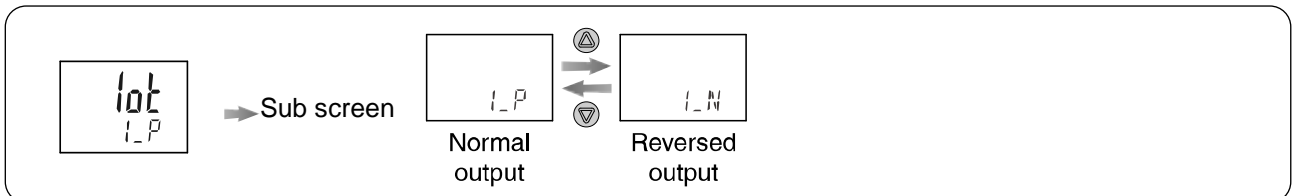

Press the or button to select reversed output mode.

Press the button to set. Move on to the input of set values(ON-OFF point).

*: If you selected accumulated pulse output mode, move on to the selection of display color (page 27).

3. Input of set values

Output mode

a. When hysteresis mode is selected



→ The sub screen displays the set value. Change it with ▲ or ▼ button.
(When reversed output is selected, the main screen displays [n_1].)

Press the ● button to set. ↓ Move on to the setting of hysteresis.

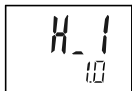

→ The sub screen displays the hysteresis value. Change it with ▲ or ▼ button.

Press the ● button to set. ↓ Move on to the selection of display color (page 27).

*: The set value and hysteresis settings limit each other.

Output mode

b. When window comparator output mode is selected.

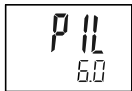

→ The sub screen displays the set value. Change it with ▲ or ▼ button.
(When reversed output is selected, the main screen displays [n1L].)

Press the ● button to set. ↓ Move on to the input of set value for [P1H] or [n1H].

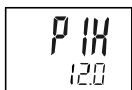

→ The sub screen displays the set value. Change it with ▲ or ▼ button.
(When reversed output is selected, the main screen displays [n1H].)

Press the ● button to set. ↓ Move on to the setting of hysteresis.

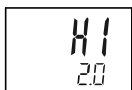

→ The sub screen displays the hysteresis value. Change it with ▲ or ▼ button.

Press the ● button to set. ↓ Move on to the selection of display color (page 27).

Output mode

c. When Accumulated output mode is selected

Selection of accumulated increment (addition) or decrement (subtraction)

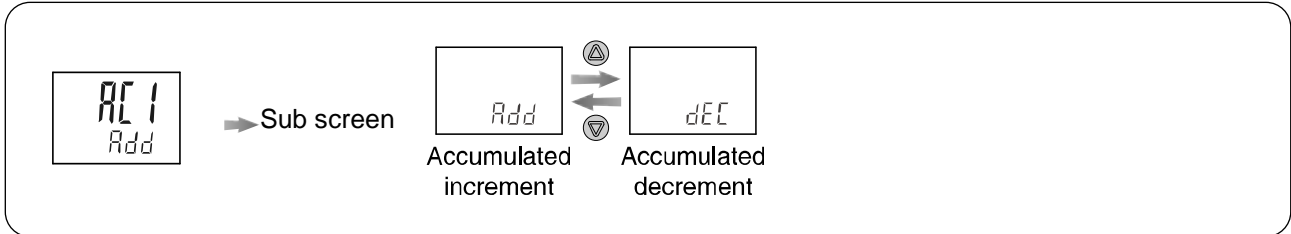

Press the or button to select the desired output mode (Add/dEC).

Press the button to set. Move on to the input of set values.

Accumulated increment mode

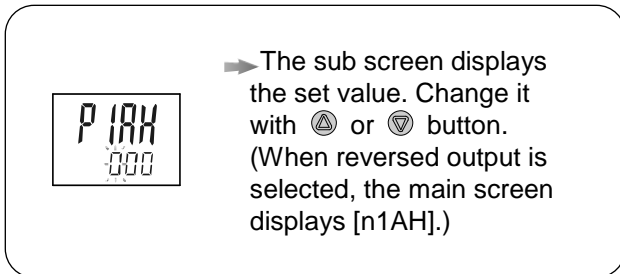

Accumulated decrement mode

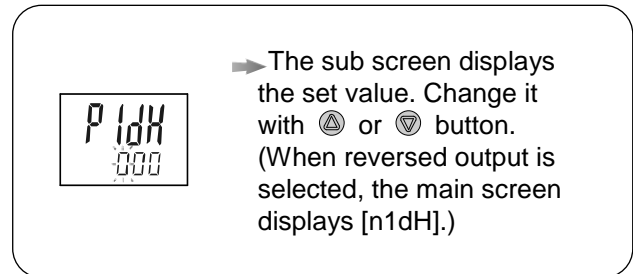



(Continued)

Setting of the upper 3 digits

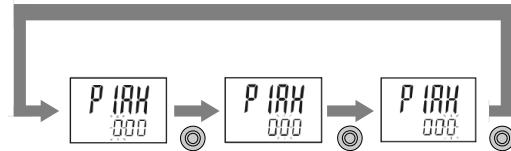
Press the  button for 1 second or longer to stop flashing.





The sub screen displays the set value. The left most digit of the set value will start flashing.
(The required accumulated value should be input one digit at a time.)

Input the value with  or  button.

Press the  button to move on to input the next digit.

Pressing the  button will select the next digit to the right.

After the input of the first 3 digits is completed, press the  button for 1 second or longer. The flashing will stop



Press the  button to again to confirm the values of the first digits and move on to the input of the next 6 digits.

Setting of the lower 6 digits

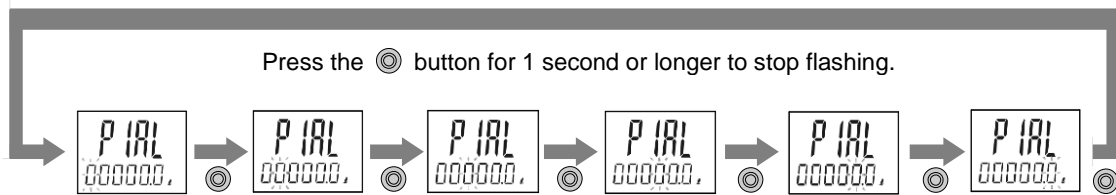
Press the  button for 1 second or longer to stop flashing.



After the input of the lower 6 digits is completed, press the  button for 1 second or longer to confirm.

Press the  button to set.  Move on to the selection of display color.

Output mode

d. When Accumulated pulse output mode is selected

There is no item to set.

4. Select display color

The display color can be set to change depending upon the status of OUT1.

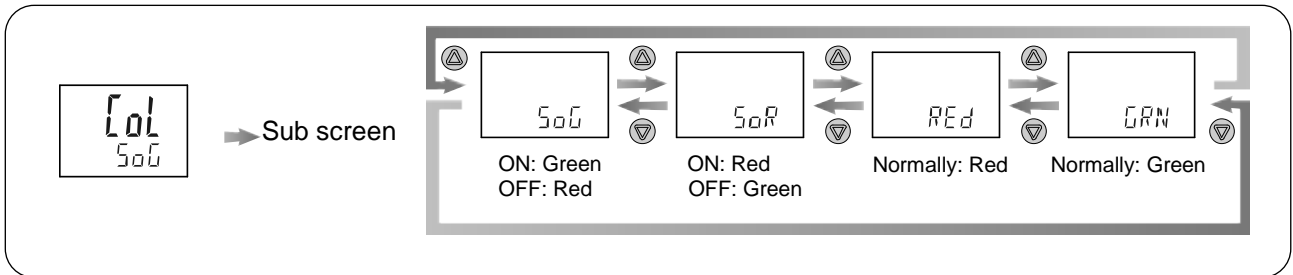

Press the ▲ or ▼ button to select the display color.

Press the ● button to set. ↓ Return to function selection mode.

5. Completed

[F 1] Setting of OUT1 complete.

List of output mode

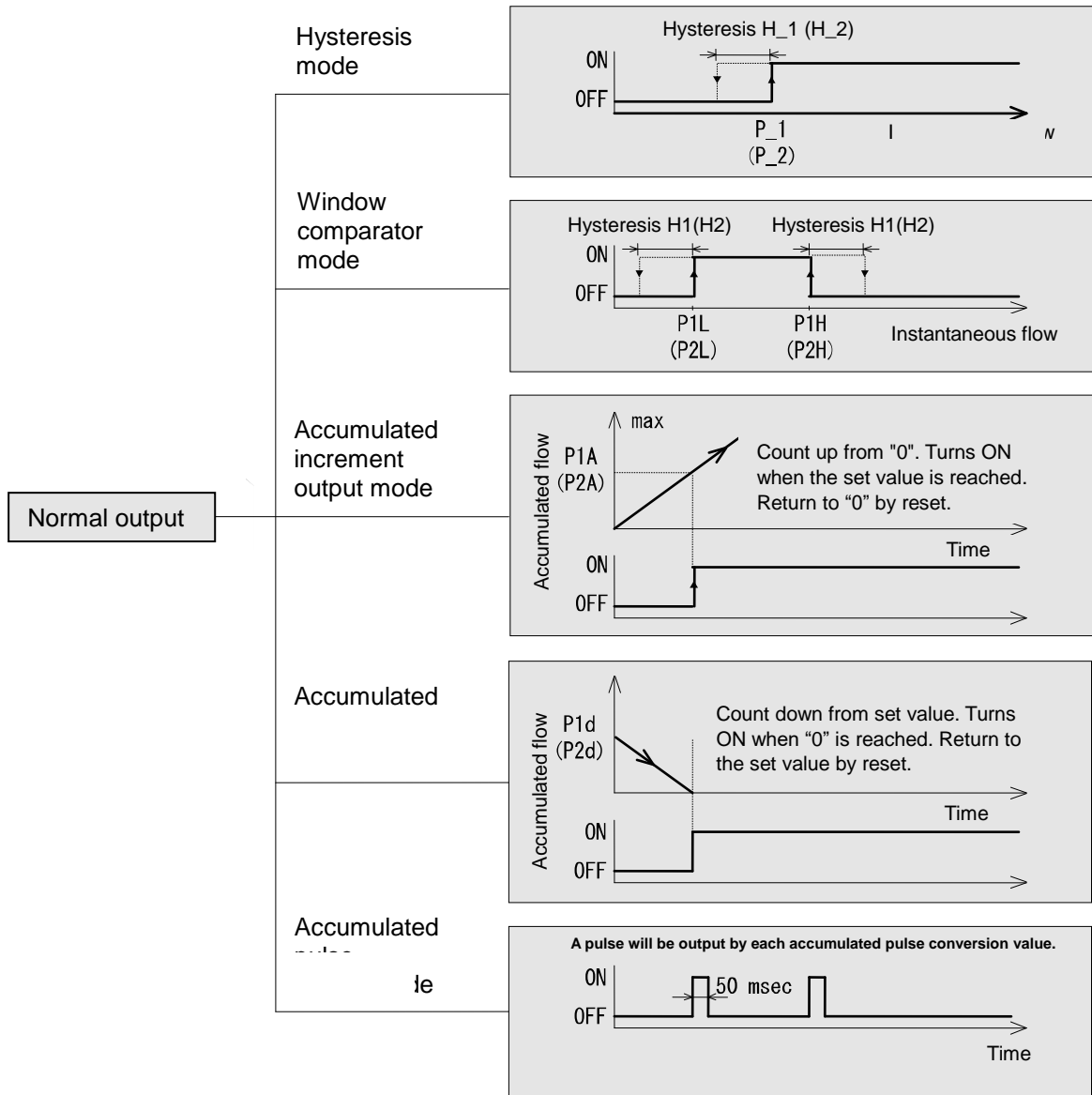

*: If hysteresis or window comparator mode are selected during unstable flow conditions (due to fluid pulsation, for example), unstable output operation can result.

In such situations, keep sufficient margin between the set values and confirm that the output operation stabilizes.

*: When the accumulated pulse output is selected, the indicator light will turn off. Use the accumulated pulses to obtain the accumulated flow based on the accumulated volume per pulse (page 62).

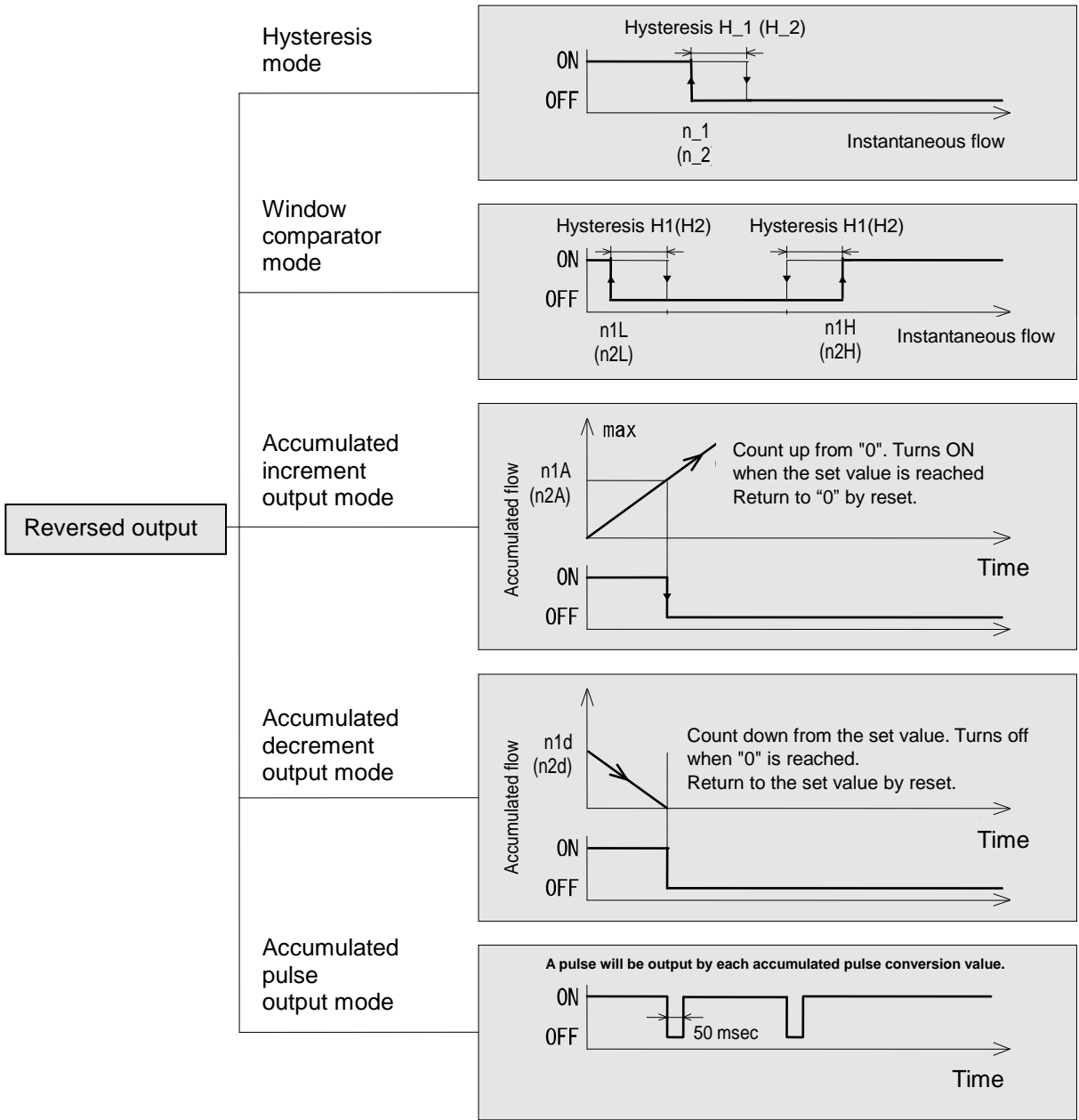

■ [F 2] Setting of OUT2

Set the output mode of OUT2.

The display color is defined by OUT1 and cannot be changed with any OUT2 settings

<Function setting Flowchart>

1. Selection of output mode

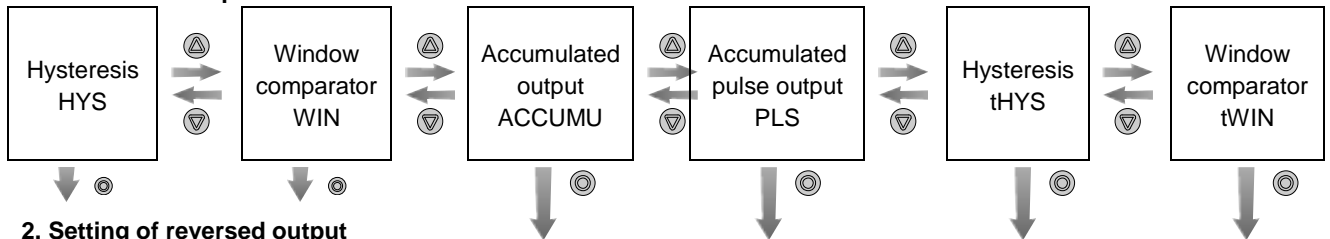

2. Setting of reversed output

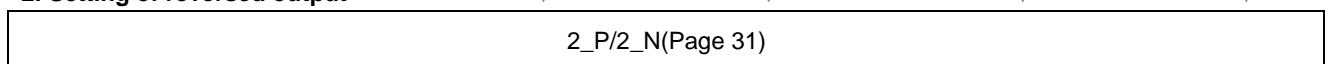

3. Input of set values

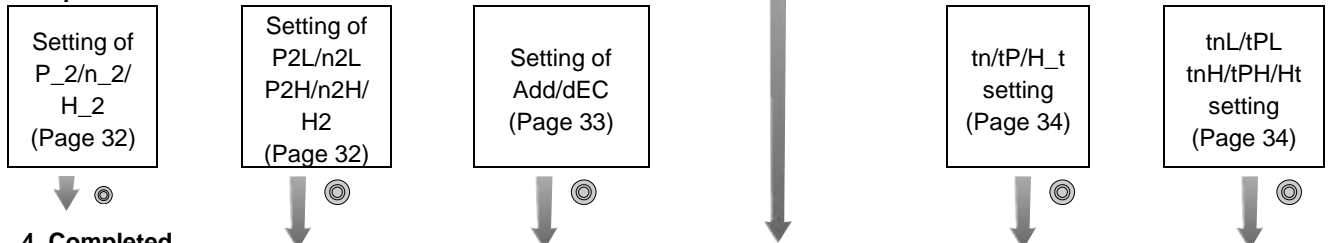

4. Completed

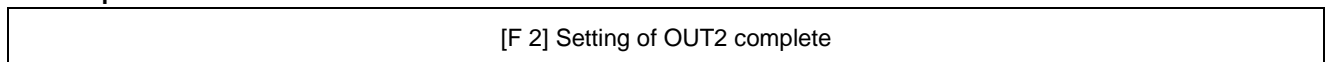

<Operation>

1. Selection of output mode

Press the or button in function selection mode to display [F 2] on the main screen.

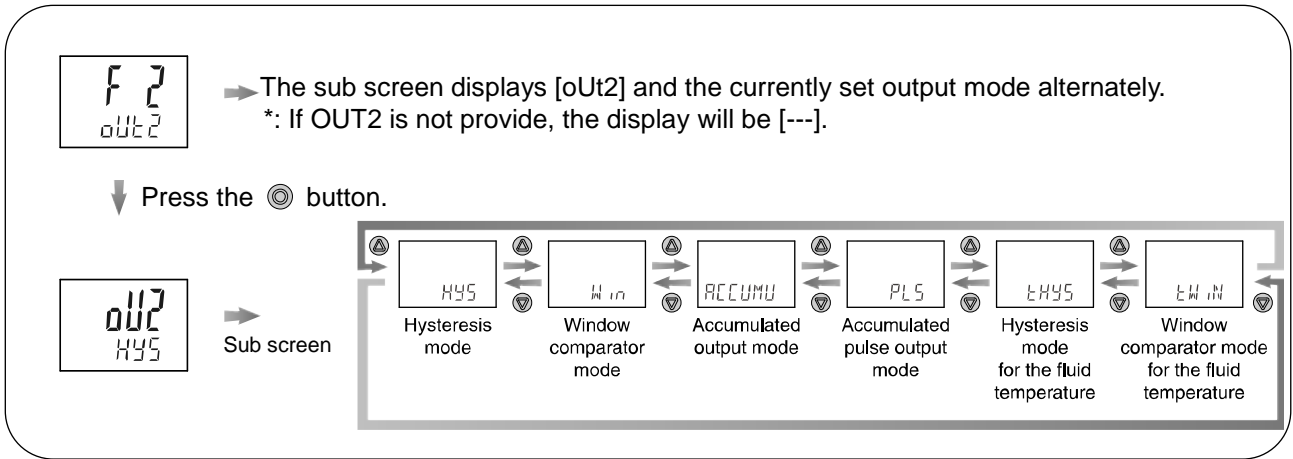

Press the or button to select the desired output mode.

Press the button to set. Move on to the setting of reversed output.

* Hysteresis/ comparator mode for fluid temperature are items which are not used for this product.

2. Setting of reversed output

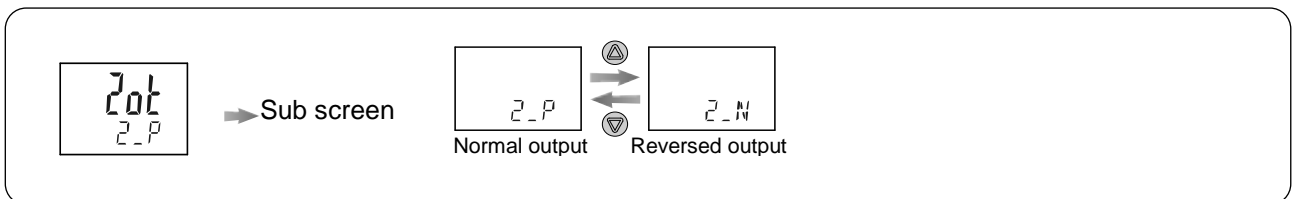

Press the or button to select reversed output mode.

Press the button to set. Move on to the input of set values (ON-OFF point).

*: When the accumulated pulse output is selected, the setting has been completed now.

3. Input of set values

Output mode

a. When hysteresis mode is selected

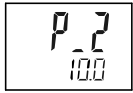

→ The sub screen displays the set value. Change it with ▲ or ▼ button.
(When reversed output is selected, the main screen displays [n_2].)

Press the ● button to set. ↓ Move on to the setting of hysteresis.

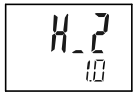

→ The sub screen displays the hysteresis value. Change it with ▲ or ▼ button.

Press the ● button to set. ↓ Return to function selection mode.

[F 2] Setting of OUT2 complete.

*: The set value and hysteresis settings limit each other.

Output mode

b. When window comparator mode is selected.

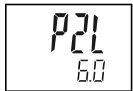

→ The sub screen displays the set value. Change it with ▲ or ▼ button.
(When reversed output is selected, the main screen displays [n2L].)

Press the ● button to set. ↓ Move on to the input of set value for [P2H] (or [n2H])

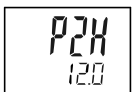

→ The sub screen displays the set value. Change it with ▲ or ▼ button.
(When reversed output is selected, the main screen displays [n2H].)

Press the ● button to set. ↓ Move on to the setting of hysteresis.

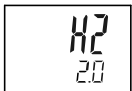

→ The sub screen displays the hysteresis value. Change it with ▲ or ▼ button.

Press the ● button to set. ↓ Return to function selection mode.

[F 2] Setting of OUT2 complete.

Output mode

c. When Accumulated output mode is selected

Selection of accumulated increment or decrement

Switching of Add/dEC is linked to the setting of OUT1, and cannot be selected. (Refer to page 25)

Accumulated increment mode



→ The sub screen displays the set value. Change it with ▲ or ▼ button. (When reversed output is selected, the main screen displays [n2AH].)

Accumulated decrement mode



→ The sub screen displays the set value. Change it with ▲ or ▼ button. (When reversed output is selected, the main screen displays [n2dH].)

For details, refer to c. When accumulated output mode is selected" on (page 31)

Press the ● button to set. ↓ Return to function selection mode.

[F 2] Setting of OUT2 complete.

Output mode

d. When Accumulated pulse output mode is selected

There is no item to set.

Output mode

e. When hysteresis mode for fluid temperature is selected

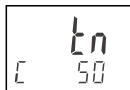

➡ The sub screen displays the set value. Change it with the or button.
(When normal output is selected, [P1dH] will be displayed.)

Press the button to confirm. Move on to the setting of hysteresis.

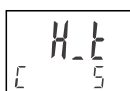

➡ The sub screen displays the set value. Change it with the or button.

Press the button to confirm. Return to function selection mode.

4. Completed

[F 2] Setting of OUT2 is completed

* Items which are not used for this product.

Output mode

f. When window comparator mode for fluid temperature is selected.

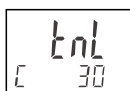

➡ The sub screen displays the set value. Change it with the or button.
(When normal output is selected, the main screen displays [tPL].)

Press the button to confirm. Move on to the input of set values for [tPH] (or [tNH]).

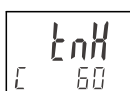

➡ The sub screen displays the set value. Change it with the or button.
(When normal output is selected, the main screen displays [tPH].)

Press the button to confirm. Move on to the setting of hysteresis.

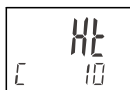

➡ The sub screen displays the set value. Change it with the or button.

Press the button to confirm. Return to function selection mode.

4. Completed

[F 2] Setting of OUT2 is completed

*: The left most digit [c] shows Centigrade (°C). [F] shows Fahrenheit [°F] shows Fahrenheit.

* Items which are not used for this product.

List of output modes for fluid temperature

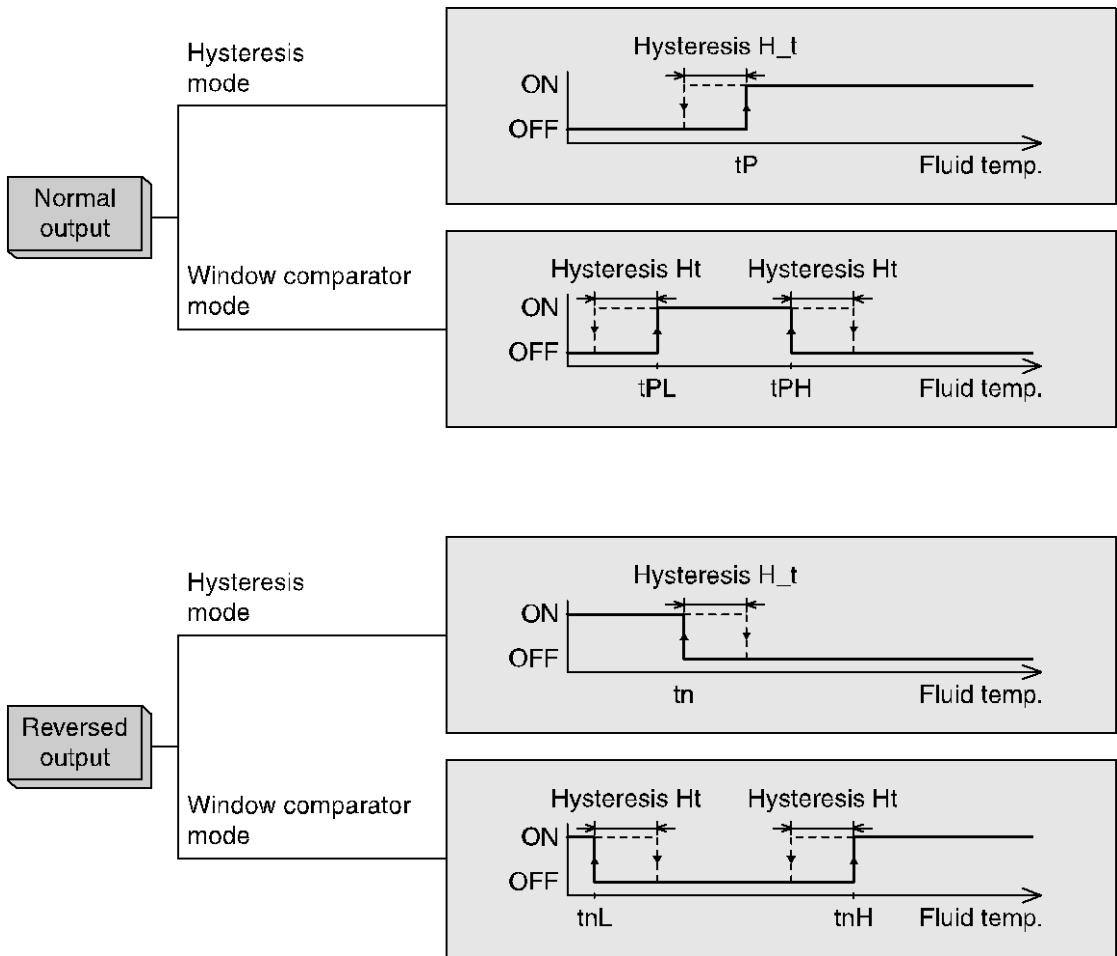



■[F 3] Response Time



The response time of the switch output can be set.

Appropriate setting of the response time can prevent the switch output from chattering.

<Operation>

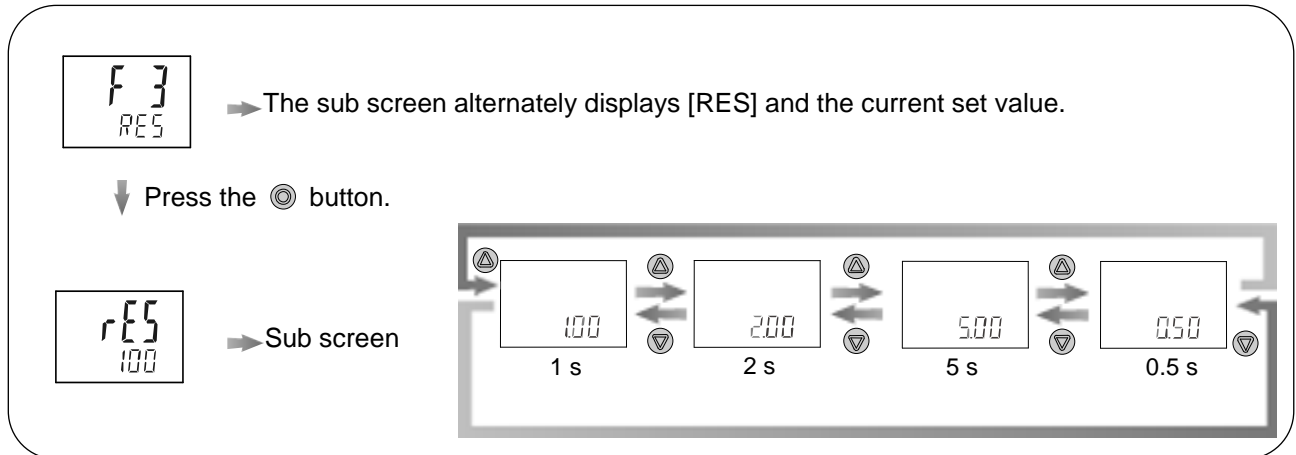
Press the  or  button in function selection mode to display [F 3] on the main screen.



Press the  or  button to select the response time.

Press the  button to set. ↓ Return to function selection mode.

[F3] Response time setting complete.

■[F10] Sub screen display

The sub display indication during measurement mode can be selected from the following:

- Set value display: Displays the set value of OUT1 (The set values of OUT2 cannot be displayed.)
- Accumulated flow display: Displays the accumulated flow of OUT1 (The accumulated flow of OUT2 cannot be displayed.)
- Bottom display: The bottom value of fluid is displayed.
- Peak display: The peak value of fluid is displayed.
- Line name display: Displays the line name
- Fluid temperature display: Shows fluid temperature.
- Temperature bottom display: The bottom value of fluid temperature is displayed.
- Temperature peak display: The peak of fluid temperature is displayed.
- OFF: Displays nothing

<Operation>

Press the or button in function selection mode to display [F10] on the main screen.

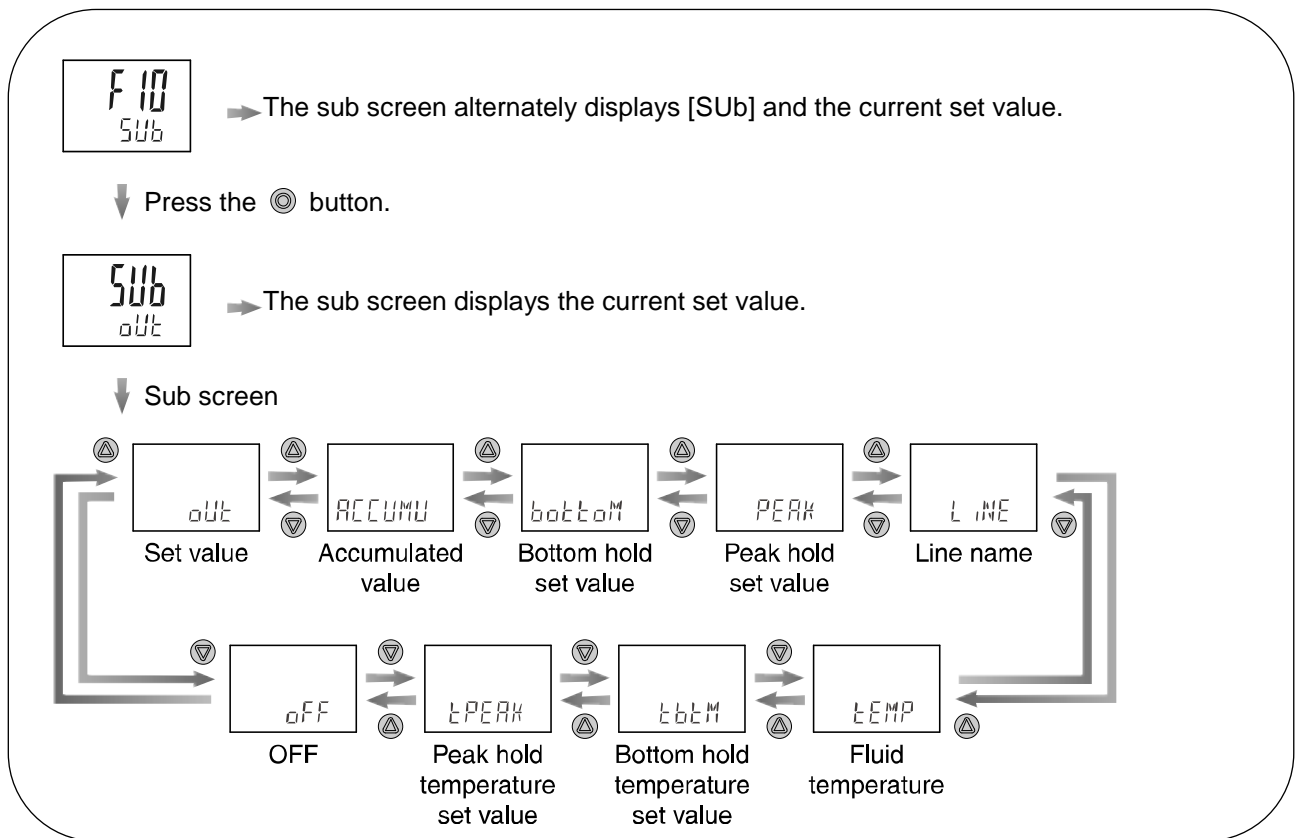

Press the or button to select the desired display.

Press the button to set. ↓ Return to function selection mode.

[F10] Sub screen display is complete.

* Temperature peak, temperature bottom, and fluid temperature display are features which are not used for this product.

<Example of sub screen display>

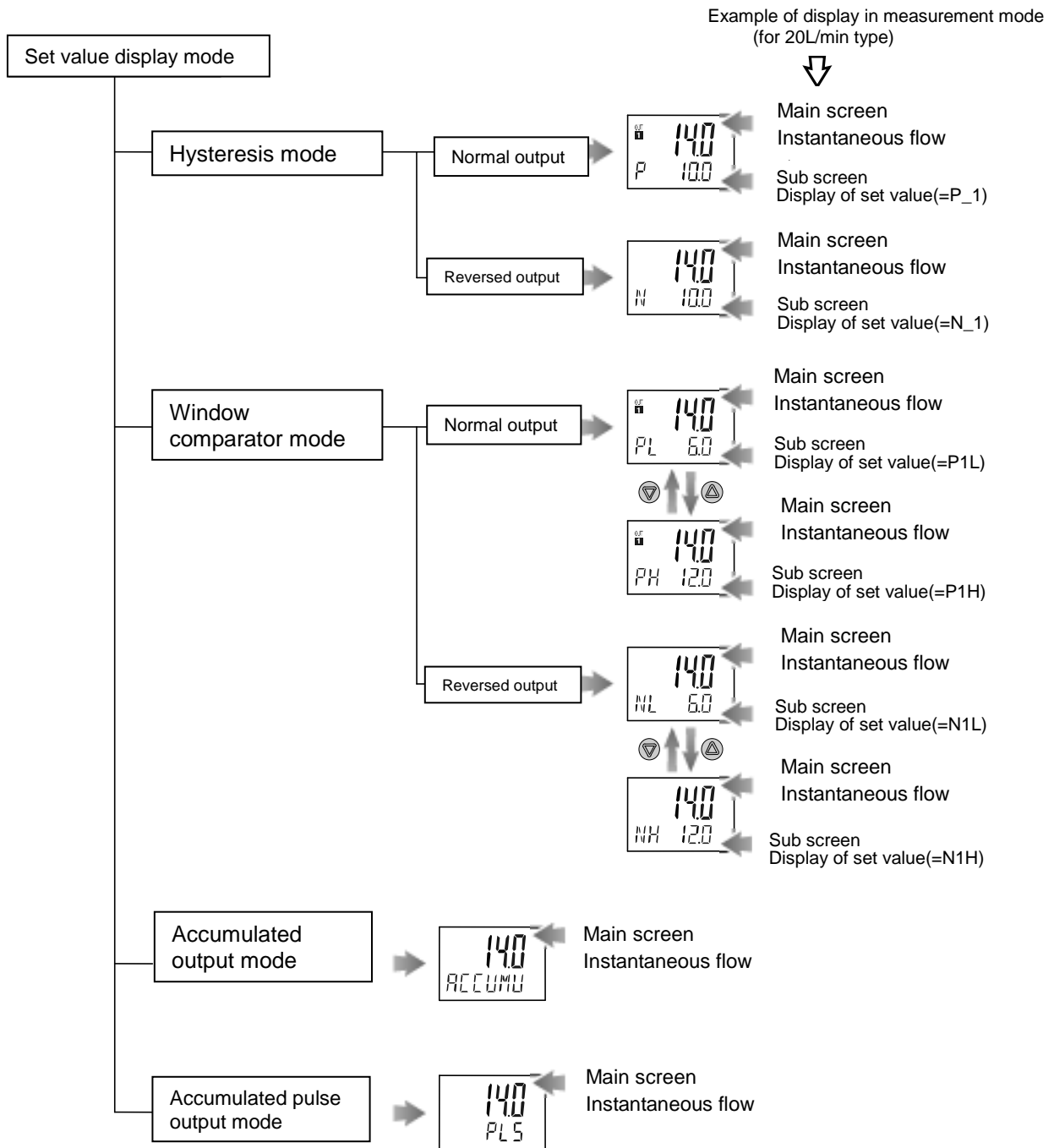

<Example of sub screen display (continued)>

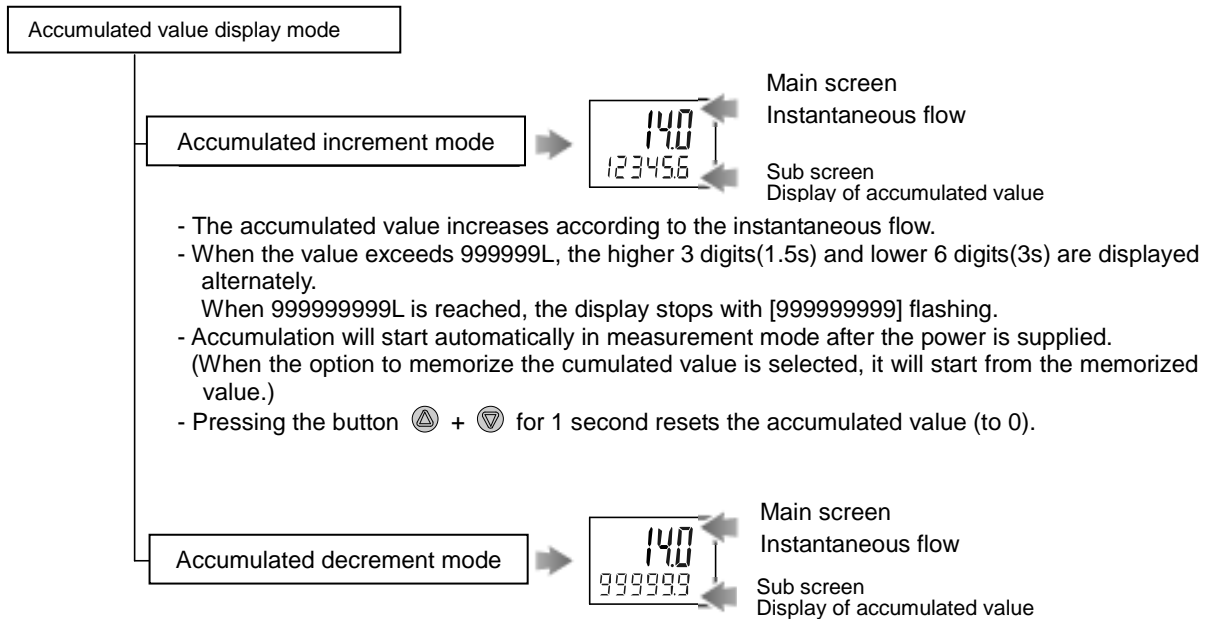

- The cumulative value decreases from the set value according to the instantaneous flow.
- When the value exceeds 999999L, the higher 3 digits(1.5s) and lower 6 digits(3s) are displayed alternately.
- Below 999999L, only the lower 6 digits are displayed.
- When the accumulated value decreases to 0, the display stops with [0] flashing.
- Accumulation will start automatically in measurement mode after the power is supplied. (When the option to memorize the cumulated value is selected, it will start from the memorized value.)
- Pressing the button + for 1 second resets the accumulated value (returns to the set value).



Displays the maximum flow rate (= peak value) or minimum flow rate (= bottom value) from the time power is supplied to current time.

Pressing + for 1 second clears the peak and bottom.

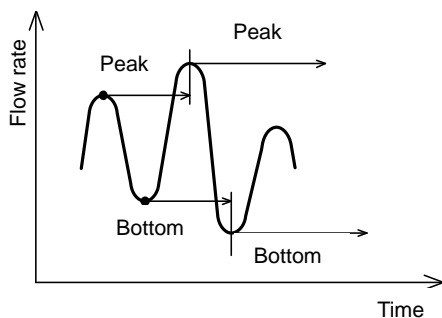

<Example of sub screen display (continued)>



The name of the piping line where the product is installed can be displayed.
Refer to [F82] Input of line names on page for how to input the line name (page 47).

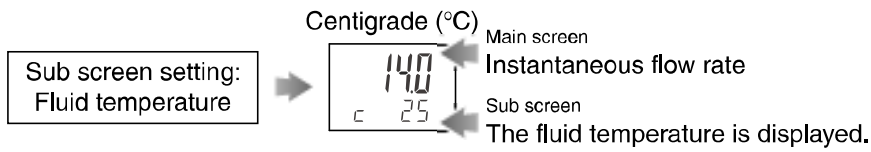

If a fluid temperature sensor is attached, the fluid temperature can be displayed as well.
The left most digit shows Centigrade (°C).

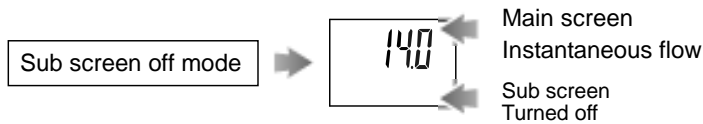

The sub display can be turned off.

■ [F20] External input

This item is not used for this specification.

■ [F22] Analogue output in free range

This function can be used only when the optional analogue output is present.

If the optional temperature sensor is fitted, the analogue output of fluid temperature can be selected.

The maximum value of analogue outputs can be set as any flow rate value within the rated range.

<Operation>

Press the or button in function selection mode to display [F22] on the main screen.

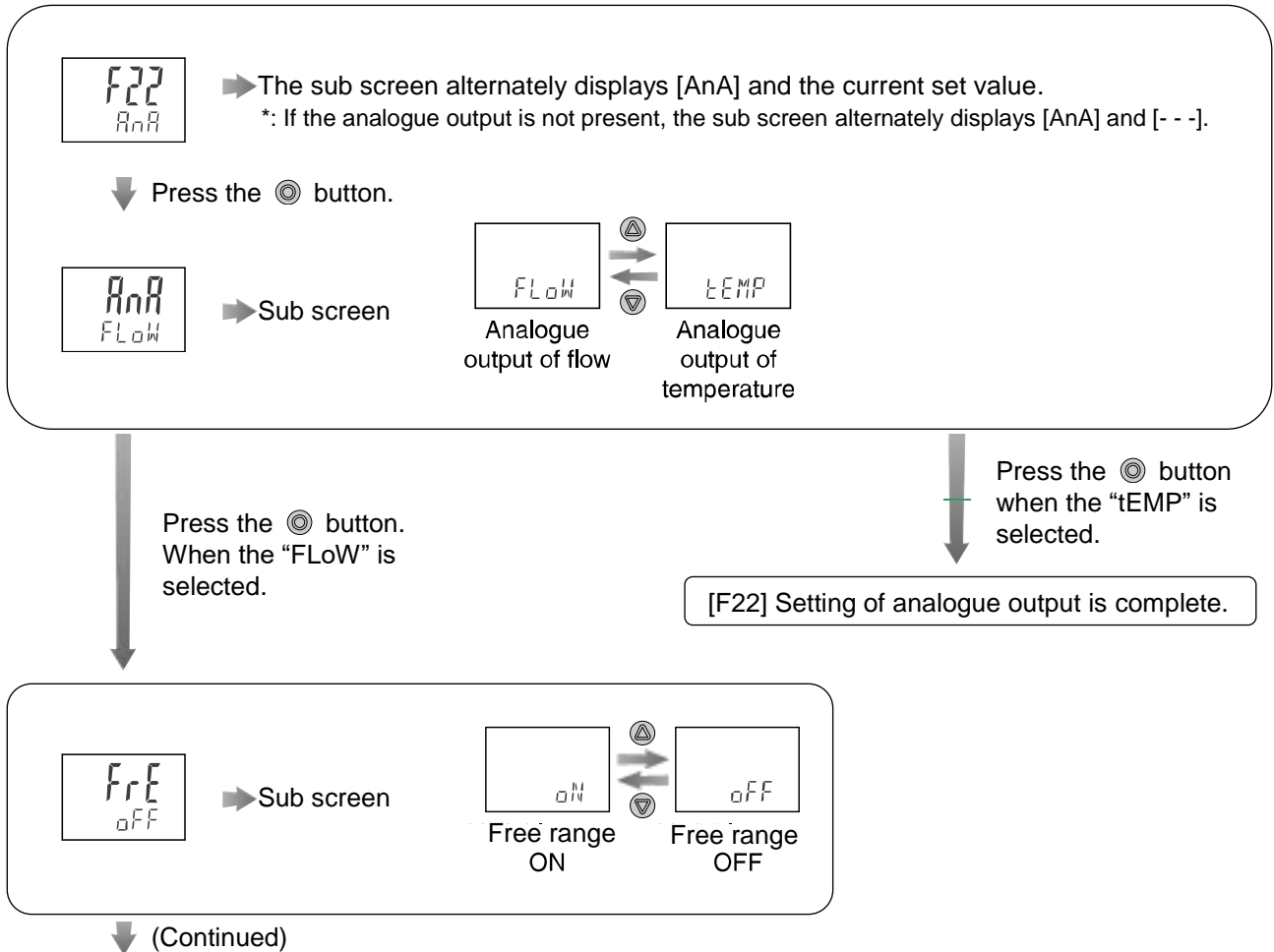

* Temperature analogue output is not used for this product.



Press the  button.

OFF

ON



Sub screen

Use the  and  buttons to enter the flow value that will generate 5 V or 20 mA. The entered flow value can be in the range: 10% rated flow, to the upper display limit.

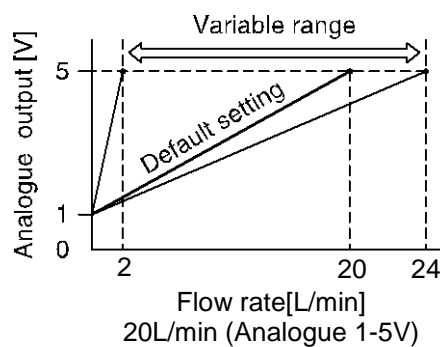

Press the  button to set.  Return to function selection mode.

[F22] Analogue output setting complete.

Turn the power off and turn it on again if the setting of analogue output is changed.

■[F30] Accumulated flow value hold

The default setting is to clear the accumulated flow value when the power supply is turned off. This function enables the accumulated flow value to be stored in permanent memory every 2 or 5 minutes. The maximum writable limit of the memory device is 1 million cycles. Therefore, calculate the number of times and use within the life.

If the product is operated 24 hours per day, the product life will be as follows:

Data memorized every 5 minutes --- 5 minutes x 1 million cycles = 5 million minutes = 9.5 years

Data memorized every 2 minutes --- 2 minutes x 1 million cycles = 2 million minutes = 3.8 years

<Operation>

Press the or button in function selection mode to display [F30] on the main screen.

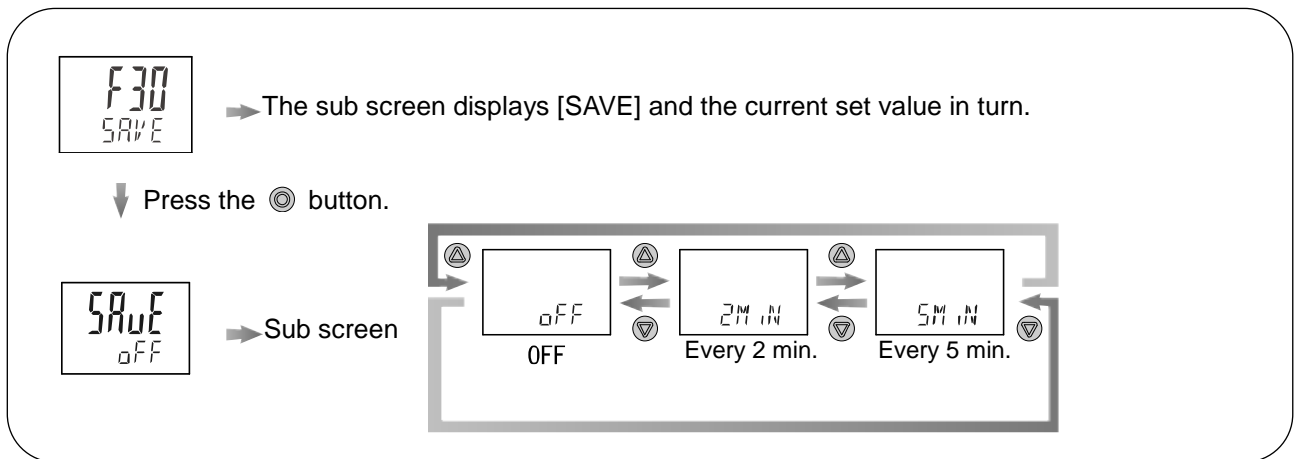

Press the or button to select the accumulate flow value hold.

Press the button to set. Return to function selection mode.

[F30] Setting of accumulated flow value hold complete.

*: Data is stored every 2 or 5 minutes (depending upon the setting chosen). This means that the accumulated flow value for up to 2 or 5 minutes before the power supply is turned off will not be added to the device memory.

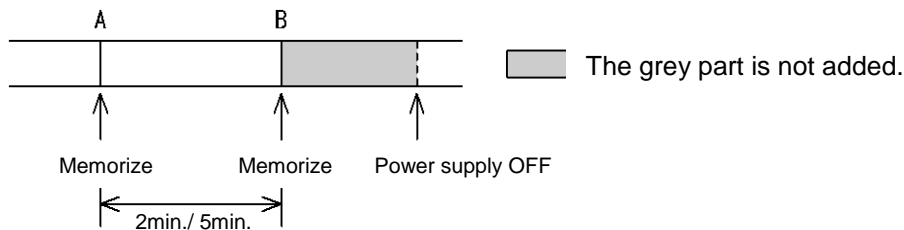

When the power supply is turned on again, the accumulated flow count will start from the last value recorded at B

■[F80] Power saving mode

The display can be turned off to reduce power consumption. (Reduced by approx. 12%)

When this function is selected, if no buttons are pressed for 30 seconds, the display will enter power saving mode.

In the default setting, power saving mode is OFF (display is ON).

<Operation>

Press the  or  button in function selection mode to display [F80] on the main screen.

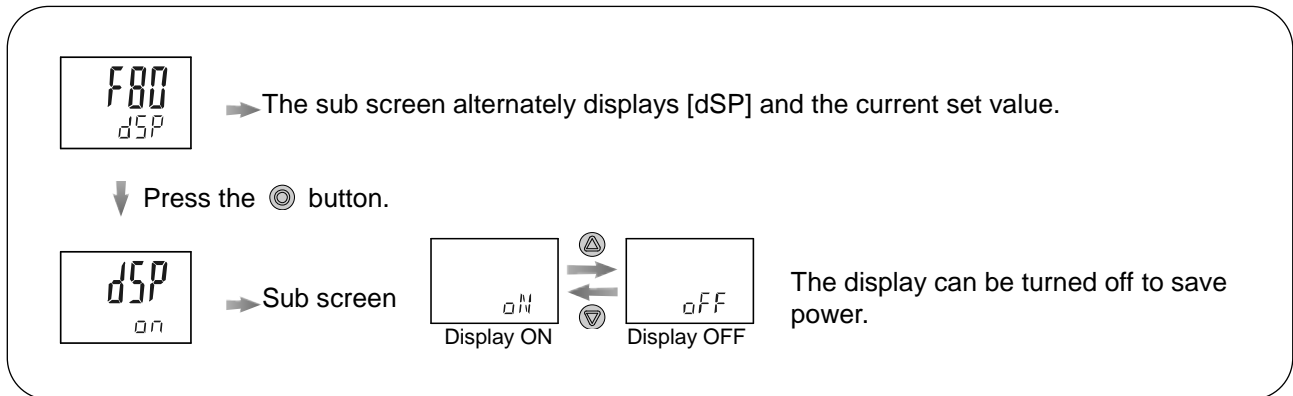

Press the  or  button to select the power saving mode setting.

Press the  button to set. ↓ Return to function selection mode.

[F80] Setting of power saving mode complete.

In power saving mode, the decimal points on the main display will flash.

When any button is activated, the display will turn on. If no button operation is performed within 30 seconds, the display will turn off again.



■ [F81] Security Code Request

You can set it to require a security code when unlocking the key.

For the key-lock function, refer to page 55.

In the default setting, the security code is set to [000], and security code request is invalid.

<Operation>

Press the  or  button in function selection mode to display [F81] on the main screen.



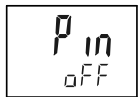

→ The sub screen displays [PiN] and the current set value in turn.

↓ Press the  button.

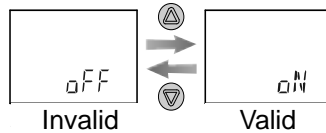

→ Sub screen



Press the  or  button to select valid or invalid for the security code request.

Press the  button to set. ↓ Return to function selection mode.

[F81] Setting of security code request complete.

■ [F82] Input of line names

A line name can be input (up to 6 characters and/or numbers). The sub display setting can be changed to show a line name. (Refer to [F10] Sub screen display on page 37.)

<Operation>

Press the or button in function selection mode to display [F82] on the main screen.



→ The sub screen alternately displays [LINE] and the line name.

↓ Press the button.

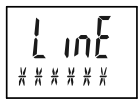

→ Sub screen

The leftmost digit flashes. Operate with or button.

The digit changes like *→Space→A→b→C· · · X→y→Z→0→1· · ·
8→9→_→_→_→_→/_→*

Select the letter you want to display.

Press the button. (Less than 1 sec.) ↓ The next digit to the right will flash and can be edited.
(Follow the same procedure for the remaining digits.)

After inputting 6 digits

Press the button for 1 seconds or longer. ↓ Flashing stops.

Press the button to set. ↓ Return to function selection mode.

[F82] Line name setting complete.

<When a dot [.] is displayed at the bottom left of each digit>



To set the dot: During , when the appropriate digit is flashing, press the and buttons simultaneously for 1 second or longer.

To remove the dot: Perform the same button operation as described above.

■ [F90] Setting of all functions

All functions can be set one after the other, without having to select each one separately from the function selection mode.

<Operation>

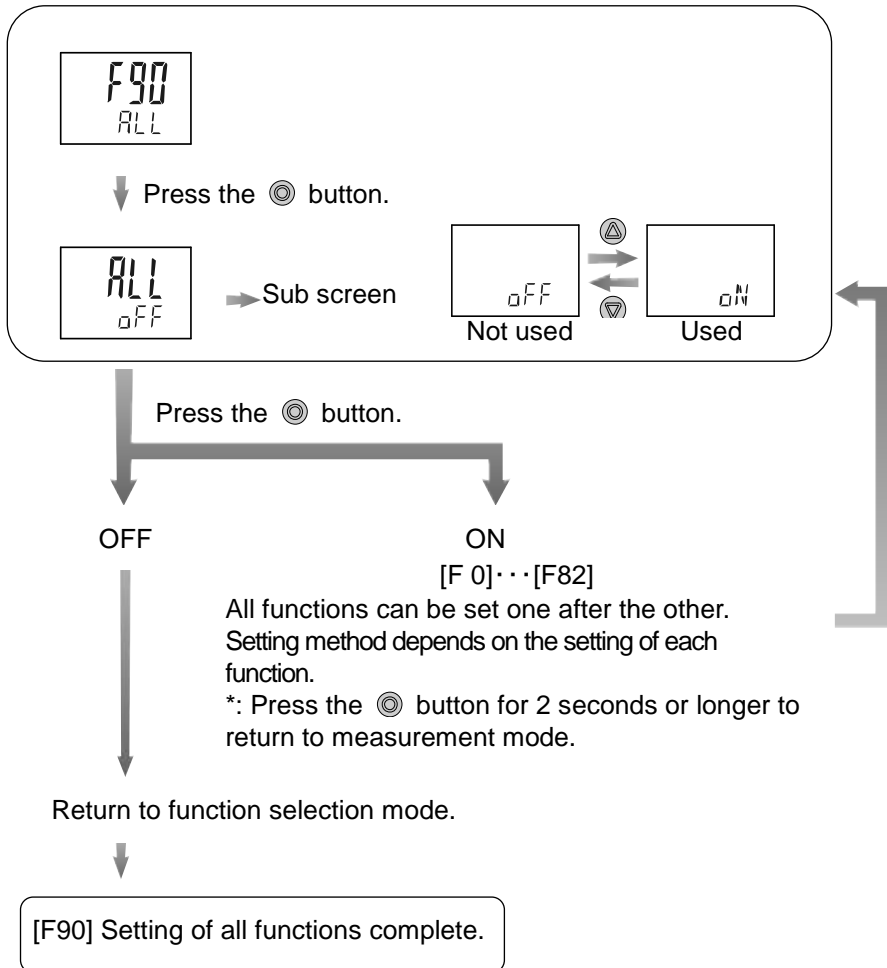

Press the  or  button in function selection mode to display [F90] on the main screen.





■[F96] Input value check

It is possible to check the voltage values (sensor output values) input to INPUT 1.

<Operation>

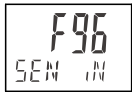
Press the  or  button in function selection mode to display [F96] on the main screen.



↓ Press the  button.

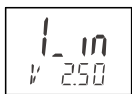

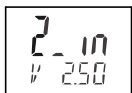

Displays the voltage value currently selected on the sub screen.

↓ Press the  button.



Displays the voltage value currently selected on the sub screen.

Press the  button to select INPUT 1 or INPUT2.

Press the  button to confirm. ↓ Return to the function selection mode.

[F96] Input value check is complete.

*: This product uses only INPUT1.In INPUT2, the sensor signal is not connected.

*: If zero is input to INPUT1 and INPUT2, the input displayed may not be zero due to the adjustment error of the electric circuit.
However, this is not an error. When input values are entered, they will be displayed correctly.

■[F97] Selection of copy function

The set values can be copied. The set values of flow rate and functions (except for fine adjustment of display value) can be copied. When the output specifications (switch output or analogue output) and/or unit specifications are the same, this function becomes available. The set value can be copied up to 10 units simultaneously.

<Connection>

The power supply should be turned off before connecting the flow monitors.

Connect the copy source flow monitor and the copy destination flow monitors with copy lead wire (ZS-40-Y), and turn on the power supply.

The copy source flow monitor is the flow monitor from which the setting is copied.

The copy destination flow monitor is the flow monitor to which the setting is copied.

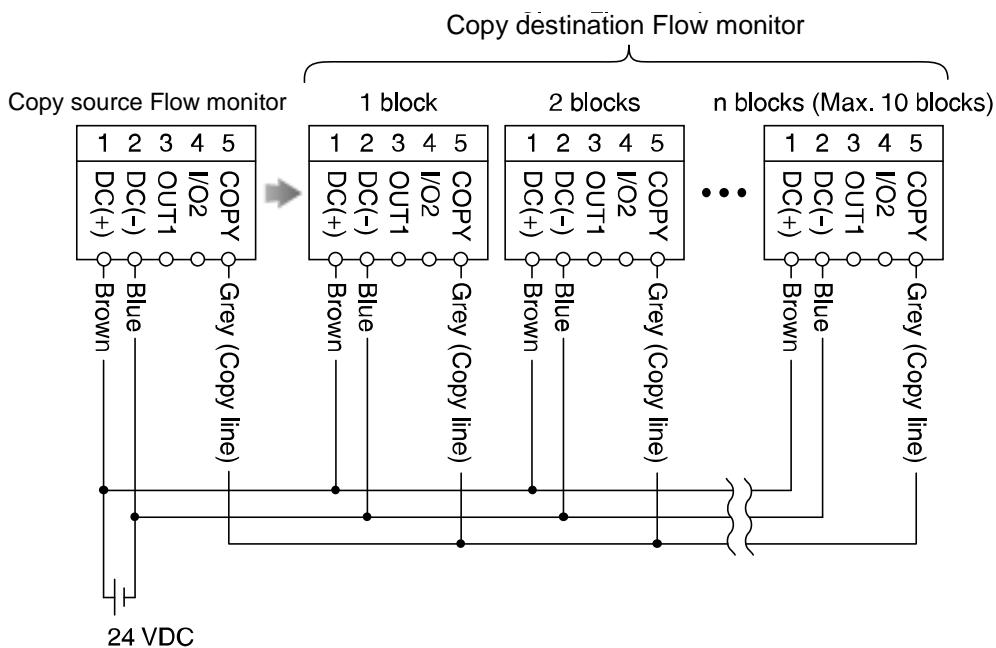

<Operation>



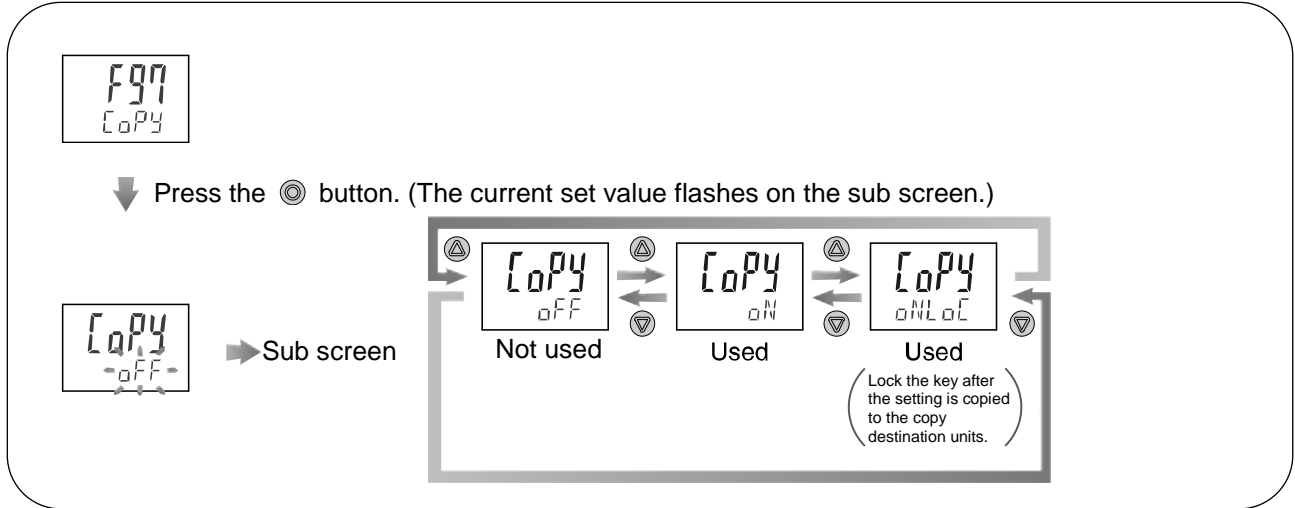

Press the or buttons to operate the copy source flow monitor in the function selection mode, and display [F97] on the main screen.

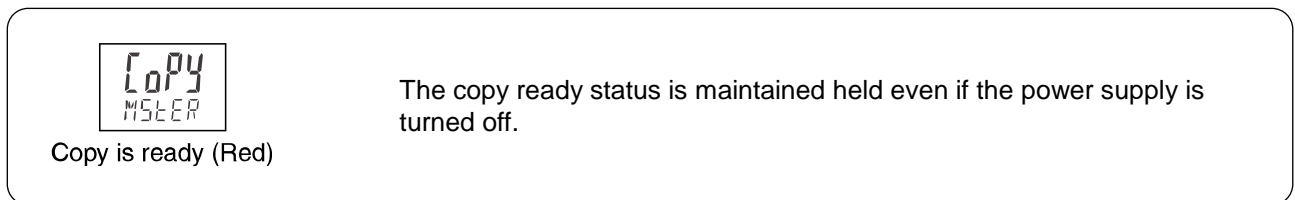
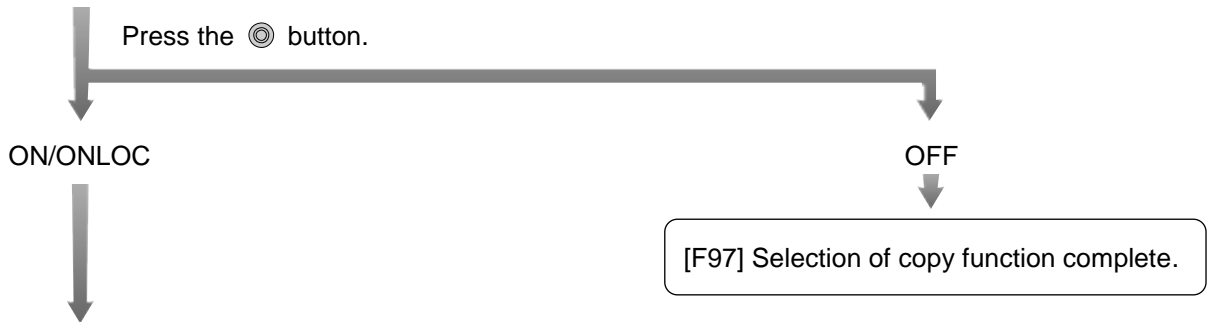

Press the or button to select copy function.

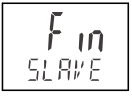

Press the button to start copying. ↓ (continued on next page)

	Copy source flow monitor	Copy destination flow monitor
Sending/ Receiving	 Blinks* (Red)	 Blinks* (Green)
Copy completed	 ON (Red)	Displayed alternately  ↔  (Green)



*They may not flash due to the timing.



Press the  button

Successive copying is possible.
The copy ready status is maintained held
even if the power supply is turned off.



Copy is ready (Red)



When completing copy function, press
the  and  buttons simultaneously
for 1 second at least.

*:Press the  and 
buttons simultaneously
for 1 seconds at least.

Press the  button

[F97] Selection of copy function is complete.

Return to measurement mode.

*: If the copy to the copy destination flow monitor is not completed, it is detected as a copying function sending/receiving error.
Press the  and  buttons simultaneously for 1 second at least to return to measurement mode.
Then check the wiring of the flow monitors and retry the copy function.

■ [F98] Output check

You can check the output operation by performing forced output.

For the analogue output type: When ON the output will be 5 V or 20 mA, and when OFF 1 V or 4 mA.

<Operation>

Press the or button in function selection mode to display [F98] on the main screen.

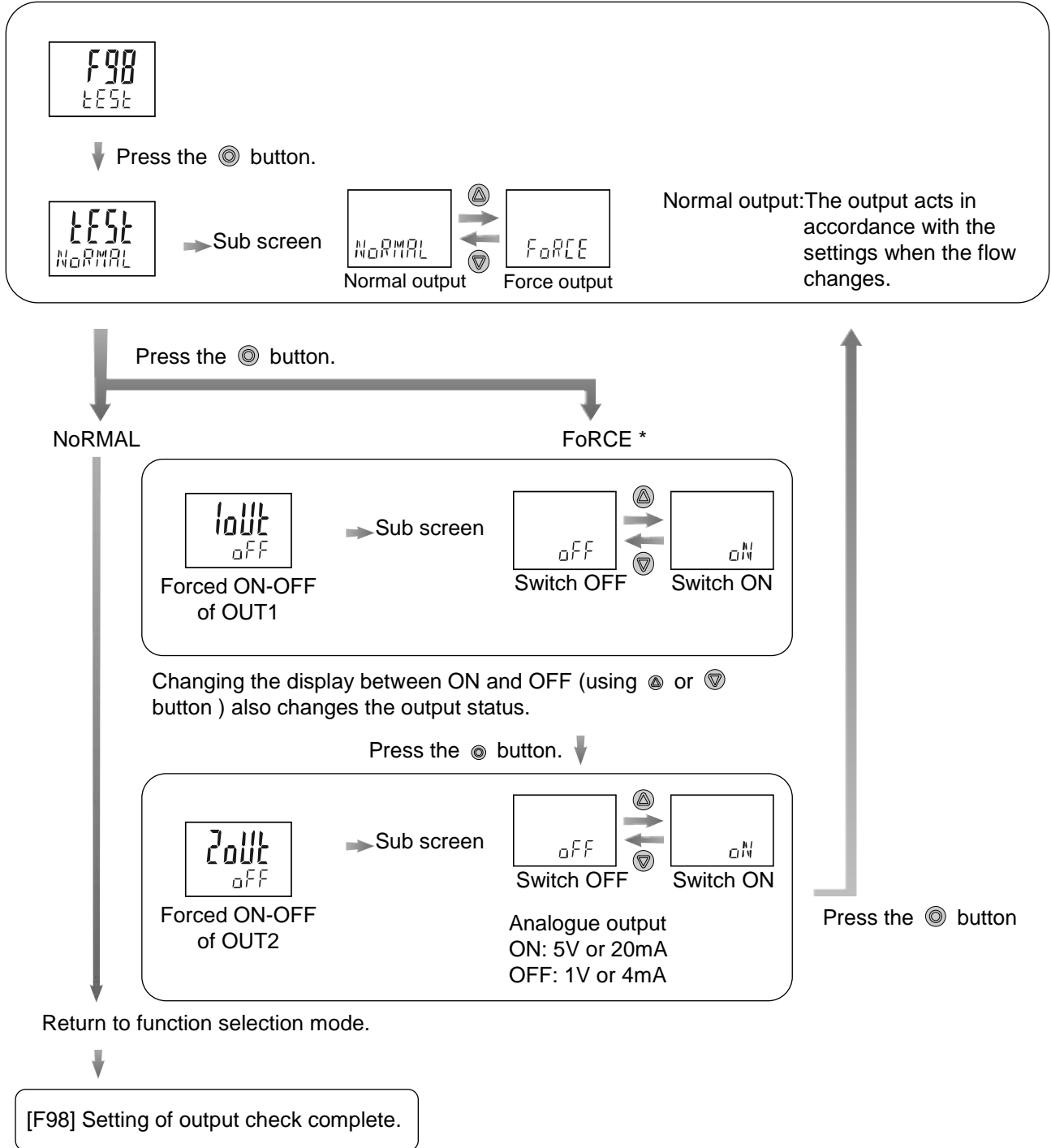



*: Press the button for 2 seconds or longer to return to measurement mode.

*: An increase or decrease in flow will have no effect on the output while the output check is being performed.



■[F99] Reset to the default settings

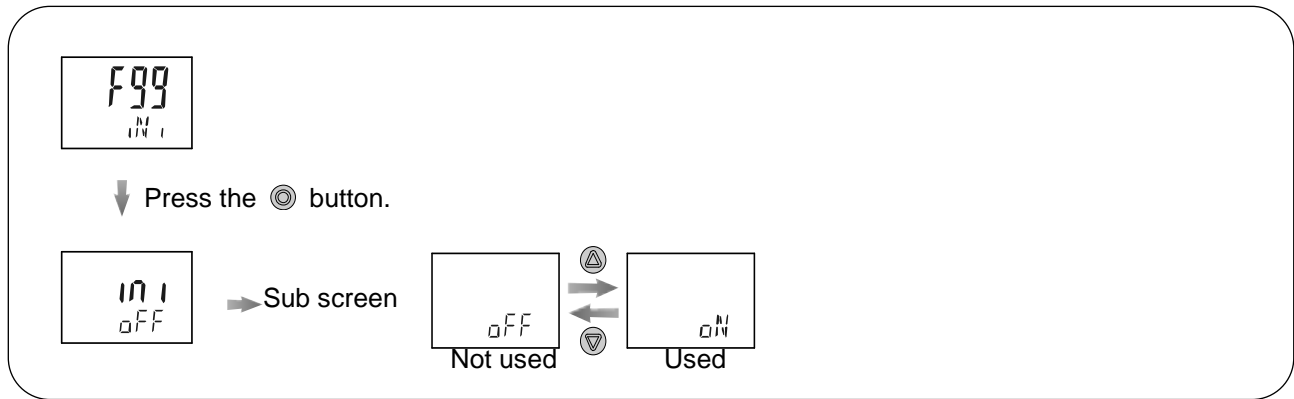

The product can be returned to the default settings.

<Operation>

Press the  or  button in function selection mode to display [F99] on the main screen.



Press the  or  button to display "ON".

Press the  and  button simultaneously for 5 seconds to restore the default settings.

*: Press the  button for 1 second or longer, the display returns to measurement mode without changing the setting.

The device automatically returns to function selection mode.

[F99] Reset to the default settings complete.



Other Settings

• Key-lock function

The key-lock function is used to prevent errors occurring due to unintentional changes of the set values. Even after the key lock has been set, the display switch is active between the simple display of the set value and the sub screen.

< Screen display during key lock >

[LoC] appears for 1 second by pressing the  button. The sub screen will scroll through the OUT1 set values. It will return to measurement mode in about 10 seconds.

Pressing the  or  buttons will change the sub screen display.

The peak and bottom hold values and the accumulated flow can be viewed, but not cleared.

<Operation when unlocking the key>

The operation for unlocking the key differs depending on the security code request [F81] (page 46).



[F81] Security code request	Security code used to cancel key lock
Invalid	Not required
Valid	Required

<When setting a key lock>

* The following key lock settings are the same for enabling / disabling the security code request [F81].

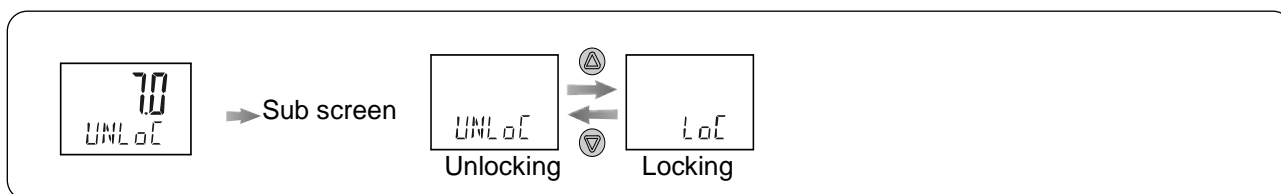
- (1) Press the  button for 5 seconds or longer in measurement mode. The current setting [UNLoC] flashes on the sub screen.







- (2) Press the  or  button to select locking [LoC].
- (3) Press the  button to select the setting. Return to measurement mode.

<When unlocking the key lock>

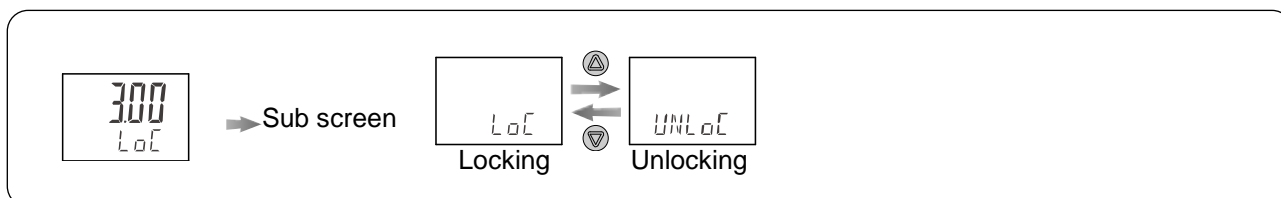
* The following procedure of cancelling the key lock should be followed when [F81] Security code request is set to invalid.

- (1) Press the  button for 5 seconds or longer in measurement mode. The current setting [LoC] flashes on the sub display.



- (2) Press the  or  button to select unlocking [UNLoC].
- (3) Press the  button to select the setting. Return to measurement mode.



*: During simple display of the set value, setting and release of key-lock is not available. Operate in measurement mode.

<When unlocking the key lock>

* The following procedure of cancelling the key lock should be followed when [F81] Security code request is set to valid.

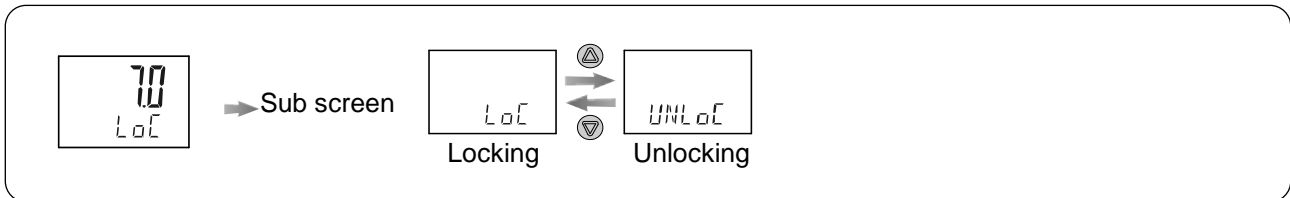
- (1) Press the  button for 5 seconds or longer in measurement mode.
The current setting [LoC] flashes on the sub display.





- (2) Press the  or  button to select unlocking [UNLoC].
- (3) After the  button is pressed, the security code must be entered.

- (4) Input of security code (3 digit setting)

The first digit will start flashing.

Press the  or  button to change the value.

Press the  button to make the next value to the right flash.

(If the  button is pressed on the far right digit, the hundreds digit will flash)

- (5) After the input is complete, press and hold the  button for 1 second or longer. The security code will be confirmed.

(If no key operation is performed for 30 seconds during input or change of the security code, the display will return to measurement mode with LoC status.)

If the security code entered is wrong, [FAL] will be indicated on the sub display.

In this case, retry inputting the security code.

If an incorrect security code is entered 3 times, the display will return to measurement mode with LoC status.



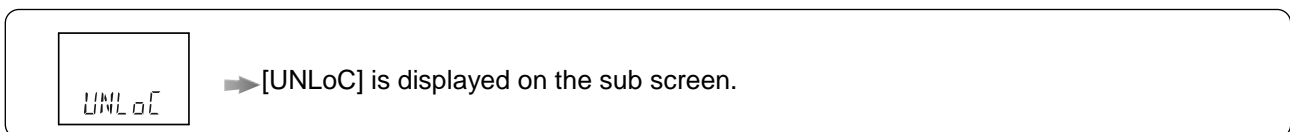
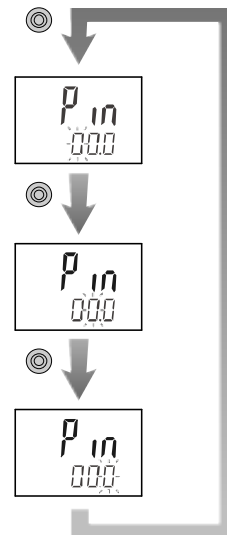







Enter 000 for the default setting.



- (6) Press the  button to complete the unlocking operation. Return to measurement mode.

■ Setting and change of security code

By the default, the security code is set to [000]. You can change the security code from [000] to any number by the following operations.

1. Suppose that [F81] Security code request is set to valid (page 46).
2. Activate the key-lock setting.
 - (1) Press and hold the  button for 5 seconds or longer in measurement mode.
The current setting will flash as [UNLoC] on the sub screen.
 - (2) Press the  or  button to select Lock [LoC].
 - (3) Press the S button to activate the key lock.
3. Deactivate the key-lock setting.
 - (1) Press and hold the  button for 5 seconds or longer in measurement mode.
The current setting will flash as [LoC] on the sub screen.
 - (2) Press the  or  button to select Unlock [UnLoC].
 - (3) After the  button is pressed, the system prompts you to enter the security code.
 - (4) Key in your security code.
 - (5) Press and hold the  button for 1 second or longer to enter the security code.
 - (6) When [UNLoC] is displayed in the sub screen, press the  and  buttons simultaneously for 5 seconds or longer.



→ [000] is displayed on the sub screen and the new security code should be entered.
Refer to page 56, (4) for input method.

↓ Press the  button for 1 seconds or longer.



→ The new security code is displayed on the sub screen.

↓ Press the  button for 1 seconds or longer. The change of security code is complete.

After the change, the status is [UNLoC]. To [LoC], perform key-lock setting again (page 55).

Maintenance and Inspection

How to reset the product after a power cut or when the power has been unexpectedly removed

The settings for the product are retained in memory prior to the power loss or de-energizing of the product. The output condition is also recoverable to that prior to the power loss or de-energizing. However, this may change depending on the operating environment. Therefore, check the safety of the whole installation before operating the product.

Troubleshooting

Applicable products: LFE series

If an operation failure occurs with the product, use the chart below to find out the cause of problem.

If a cause applicable to the failure cannot be identified and normal operation can be recovered by replacement with a new product, this indicates that the product itself was faulty. The damage to the product may have been caused by operating environment (installation location, etc.). Consult with SMC separately to obtain countermeasures.

Troubleshooting list

Fault	Detail	Possible cause	Item to check / Recommended action
Display failure / Output signal abnormal	No display / No output	Incorrect wiring / Disconnection	Check to see that the brown wire DC(+), blue wire DC(-), black wire (OUT1), and white wire (OUT2) are correctly connected to the product and that there are no broken wires.
		Loose connector	Check the Power supply/output connector is connected.
	Unstable display / output	Foreign matter in the sensor fluid passage	Check the fluid passage for any foreign matter. Remove foreign matter if necessary.
		Water supply shortage	Check to see if the fluid passage is completely filled with fluid.
		There are bubbles in the fluid path.	Place the piping in the correct position for helping discharge air bubbles.
		Pulsation in the flow.	It is recommended to place a component to reduce pulsating flow or a tank to reduce pressure fluctuation or replace the piping with elastic tubing, such as a rubber hose.
		Installed in area not suitable for mounting.	Check the products installed close together for sufficient clearance and keep a distance of 50 mm or more between them. Enabling the close proximity setting allows you to install the products in the area closer than 50 mm.
	Unstable output	Noise	Keep the wiring route away from any power or high voltage cables which may be a source of noise.
		Narrow hysteresis width, accompanied with chattering	Adjust the product so that the hysteresis width is increased to avoid the chattering.
	Incorrect display	The piping is connected in the wrong direction	Check the mounting direction of the product.
		Output load is not appropriate	Check to see if a load is correctly connected, and especially for the analogue output type, check it for correct impedance.
		Leakage occurs	Check the piping connections for insufficient torque or defective sealing which has caused the leakage.
		The sensor flow range selection is incorrect.	Select the correct flow rate range.

Fault	Detail	Possible cause	Item to check / Recommended action
The push buttons do not work	The push buttons do not react.	Key-lock mode is activated.	Press a button and check to see if the [LoC] appears in the screen. If it appears, deactivate the key-lock setting. (See page 55.)
Cannot be set	OUT1/OUT2 set value does not go down.	Hysteresis is too large.	Check the detected flow rate setting and the hysteresis, and verify that the hysteresis width is not too large for the detected flow. The detected flow rate has been set to 50% of the rated value and the hysteresis set to 5% of the rated value before shipment of the product from the factory. When setting the hysteresis width to a narrower range, take account of the occurrence of unstable display and outputs due to pulsating flow.

Error display function

Error Name	Display	Description	Troubleshooting
OUT1 over current error	Er1	A load current of 80 mA or more is flowing to the switch output (OUT1).	Turn the power off and remove the cause of the over current. Then turn the power on again.
OUT2 over current error	Er2	A load current of 80 mA or more is flowing to the switch output (OUT2).	
Excessive instantaneous flow	HHH	The flow rate is exceeding the flow rate range (the rated flow rate x 1.2).	Reduce the flow within the display flow range.
Reverse flow error / Sensor disconnection error	LLL	The flow is flowing in the reverse direction of the setting. The remote sensor is not connected to the monitor.	Apply flow in the correct direction. Connect the sensor.
Excessive accumulated flow	9999999999 (Alternately displays [999] and [999999].)	The accumulated flow range has been exceeded.	Reset the accumulated flow. (This measure is not necessary unless accumulated flow is used)
System error	Er0 Er4 Er6 Er8	Displayed if an internal data error has occurred.	Turn the power off and on again.

If the error cannot be solved after the above instructions are performed, please contact SMC for investigation.

Specifications

■ Specifications

Model	LFE0□		
Display range	0.4 to 24.0 L/min (Displays 0.0 when the value is below 0.4 L/min.)	2.0 to 120.0 L/min (Displays 0.0 when the value is below 2.0 L/min.)	4 to 240 L/min (Displays 0 when the value is below 4 L/min.)
Set point range	0.4 to 24.0 L/min	2.0 to 120.0 L/min	4 to 240 L/min
Min. setting unit	0.1 L/min	0.5 L/min	1 L/min
Accumulated volume per pulse (Pulse width=50ms)	0.1 L/pulse	0.5 L/pulse	1 L/pulse
Display unit	Instantaneous flow L/min, accumulated flow L		
Accuracy	Display value: $\pm 0.5\%$ F.S. Analogue output: $\pm 0.5\%$ F.S.		
Repeatability	$\pm 0.5\%$ F.S.		
Temperature characteristics	$\pm 0.5\%$ F.S.(25 °C reference)		
Accumulated flow range*1	99999999.9 L	999999999 L	
	By 0.1L	By 1L	
Switch output	NPN or PNP open collector output		
Maximum load current	80 mA		
Maximum applied voltage	28 VDC		
Internal voltage drop	NPN: 1 V max. (at 80 mA load current) PNP: 1.5 V max. (at 80 mA load current)		
Response time *2	Can be selected from 0.5 s,1 s,2 s,5 s		
Output protection	Short circuit protection		
Output Mode	Select from Hysteresis mode, Window comparator mode, Accumulated output mode or Accumulated pulse output mode		
Analogue output	Response time *3	Linked with the switch output	
	Voltage output	Output voltage: 1 to 5 V Output impedance: 1 k Ω min.	
	Current output	Output current: 4 to 20 mA Max. load impedance 600 Ω	
Hysteresis	Variable		
Input and output	Input for copy mode		
Display type	2 screen display (Main screen: 4 digit, 7-segment, 2 colour; red/green, Sub screen: 6 digit, 11 segment, White) Display updating interval 5 times/sec.		
Operation LED	Output 1 and 2: Orange		
Power supply voltage	24VDC $\pm 10\%$		
Current consumption	50 mA or less		
Connection method	Power supply output 5P connector, sensor connection 4P connector (e-con)		

Model		LFE0□
Environmental	Enclosure	IP40 (Note that the display front is only certified as IP65 by using optional parts (panel mount adapter and waterproof seal).
	Operating temperature range	0 to 50°C (No condensation or freezing)
	Ambient humidity range	Operation, Storage: 35 to 85%RH (No condensation)
	Withstand voltage	1000 V AC for 1 minute between external terminals and FE
	Insulation resistance	50 MΩ or more (at 500VDC) between external terminals and case
Standards		CE marking, UL (CSA), RoHS
Weight	Without lead wire	50 g
	With lead wire	100 g

- *1: The accumulated value will be cleared when the power supply is turned off. It is possible to select the function to memorize it. (Select the interval of 2 min. or 5min.)
When a 5min. interval is selected, the maximum life of the electronic memory element is 1 million writes (if energized for 24 hours, 5min. x 1 million times = 5 million minutes = Approx. 9.5 years). If accumulated value hold is used, calculate the life based on the operating conditions not to exceed the life of the product.
- *2: The response time is when the set value is 63% in relation to the step input.
- *3: The response time is when the set value reaches 63% in relation to the step input.

Specifications of lead wire (ZS-40-W)

Item		Specifications
Conductor	Nominal cross section	AWG26
	O.D.	Approx. 0.51 mm
Insulator	Material	Bridge vinyl
	O.D.	Approx. 1.00 mm
	Colours	Brown, blue, black, white, grey
Sheath	Material	Heat and oil resistant plastic
Finished O.D.		ø3.5 mm

■ Analogue output

Flow/Analogue output

	A	B	C
Voltage output	1 V	1.1 V	5 V
Current output	4 mA	4.4 mA	20 mA

Model	Rated flow [L/min]	
	Minimum	Maximum
LFE1	0.5	20
LFE2	2.5	100
LFE3	5	200

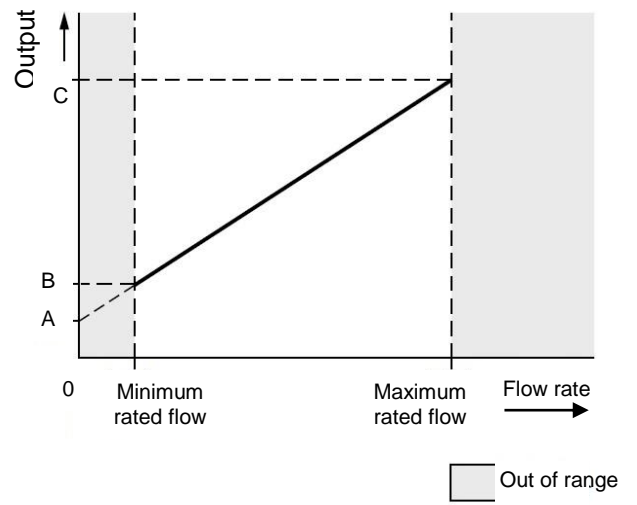

■ Dimensions

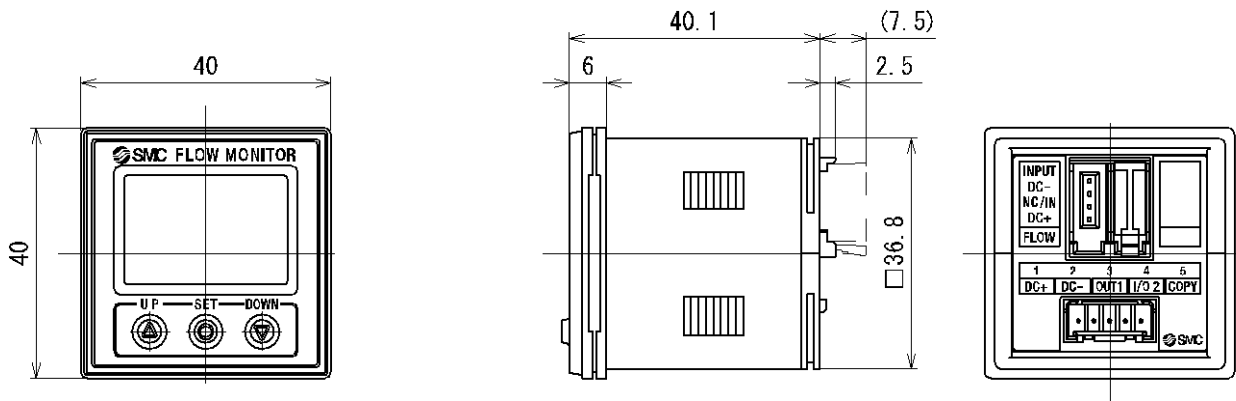

Front protective cover + Panel mount adapter

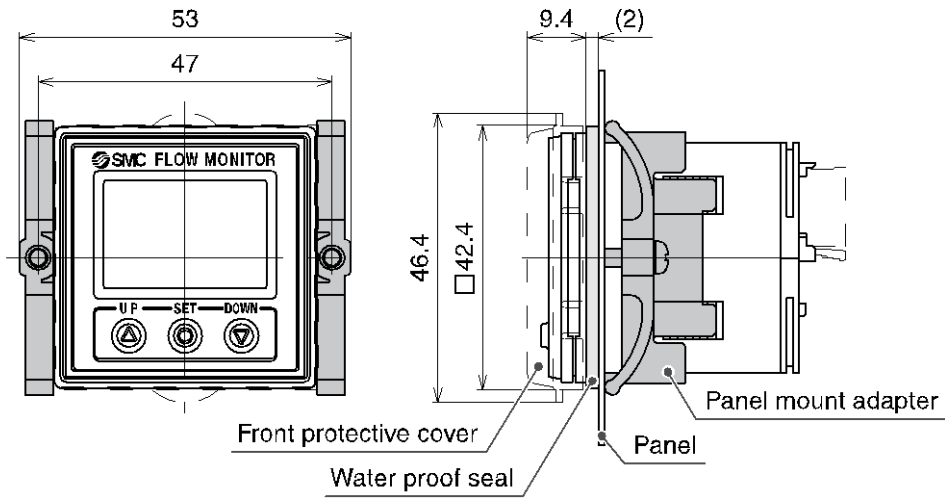

R

Cut-out dimensions for panel mounting

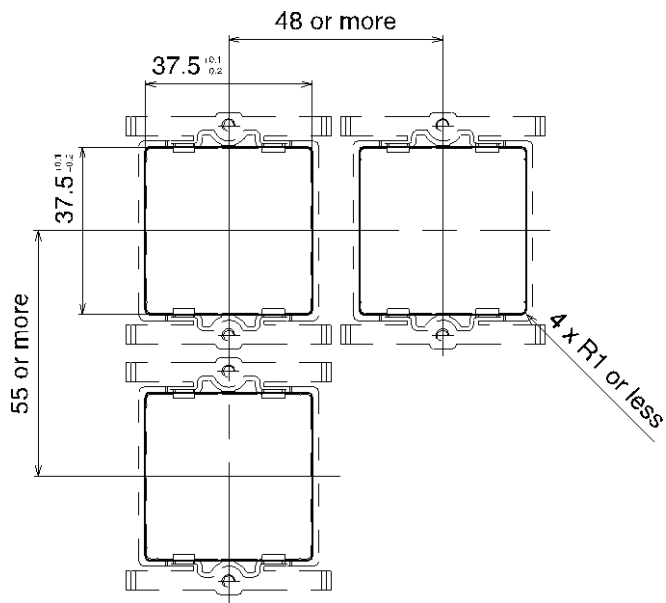

*: The thickness of the panel is 0.5 to 0.8mm (with a waterproof seal: 0.5 to 6mm).

Dimensions of power supply/output lead wire (ZS-40-W)

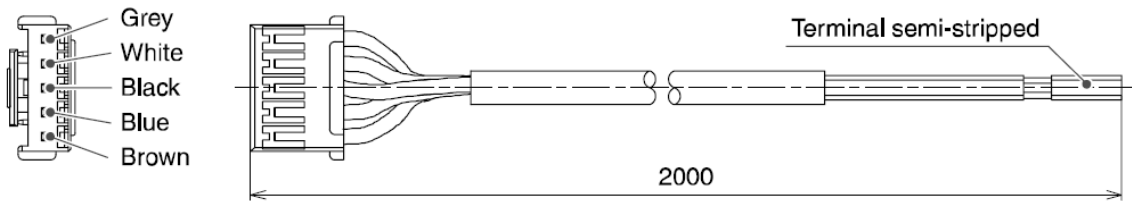

Revision

SMC Corporation

4-14-1, Sotokanda, Chiyoda-ku, Tokyo 101-0021 JAPAN

Tel: + 81 3 5207 8249 Fax: +81 3 5298 5362

URL <https://www.smcworld.com>

Note: Specifications are subject to change without prior notice and any obligation on the part of the manufacturer.
© 2022 SMC Corporation All Rights Reserved