



# Operation Manual

Product Name

Electromagnetic Digital Flow Switch

Model/ Series/ Product Number

*LFE####*

## SMC Corporation

## Contents

Safety Instructions	2
Model Indication and How to Order	11
Summary of Product Parts	13
Definitions and Terminology	14
Mounting and Installation	15
Installation	16
Piping Method	17
Wiring	19
Maintenance and Inspection	21
Troubleshooting	22
Specifications	23
Applicable Fluids	24
Characteristics Chart	25
Analogue Output	28
Dimensions	29



# Safety Instructions

These safety instructions are intended to prevent hazardous situations and/or equipment damage. These instructions indicate the level of potential hazard with the labels of "Caution," "Warning" or "Danger." They are all important notes for safety and must be followed in addition to International Standards (ISO/IEC)\*1), and other safety regulations.

\*1) ISO 4414: Pneumatic fluid power -- General rules relating to systems.

ISO 4413: Hydraulic fluid power -- General rules relating to systems.

IEC 60204-1: Safety of machinery -- Electrical equipment of machines .(Part 1: General requirements)

ISO 10218: Manipulating industrial robots -Safety.

etc.



## Caution

**Caution** indicates a hazard with a low level of risk which, if not avoided, could result in minor or moderate injury.



## Warning

**Warning** indicates a hazard with a medium level of risk which, if not avoided, could result in death or serious injury.



## Danger

**Danger** indicates a hazard with a high level of risk which, if not avoided, will result in death or serious injury.

## Warning

### 1. The compatibility of the product is the responsibility of the person who designs the equipment or decides its specifications.

Since the product specified here is used under various operating conditions, its compatibility with specific equipment must be decided by the person who designs the equipment or decides its specifications based on necessary analysis and test results.

The expected performance and safety assurance of the equipment will be the responsibility of the person who has determined its compatibility with the product.

This person should also continuously review all specifications of the product referring to its latest catalog information, with a view to giving due consideration to any possibility of equipment failure when configuring the equipment.

### 2. Only personnel with appropriate training should operate machinery and equipment.

The product specified here may become unsafe if handled incorrectly.

The assembly, operation and maintenance of machines or equipment including our products must be performed by an operator who is appropriately trained and experienced.

### 3. Do not service or attempt to remove product and machinery/equipment until safety is confirmed.

1. The inspection and maintenance of machinery/equipment should only be performed after measures to prevent falling or runaway of the driven objects have been confirmed.

2. When the product is to be removed, confirm that the safety measures as mentioned above are implemented and the power from any appropriate source is cut, and read and understand the specific product precautions of all relevant products carefully.

3. Before machinery/equipment is restarted, take measures to prevent unexpected operation and malfunction.

### 4. Contact SMC beforehand and take special consideration of safety measures if the product is to be used in any of the following conditions.

1. Conditions and environments outside of the given specifications, or use outdoors or in a place exposed to direct sunlight.

2. Installation on equipment in conjunction with atomic energy, railways, air navigation, space, shipping, vehicles, military, medical treatment, combustion and recreation, or equipment in contact with food and beverages, emergency stop circuits, clutch and brake circuits in press applications, safety equipment or other applications unsuitable for the standard specifications described in the product catalog.

3. An application which could have negative effects on people, property, or animals requiring special safety analysis.

4. Use in an interlock circuit, which requires the provision of double interlock for possible failure by using a mechanical protective function, and periodical checks to confirm proper operation.



# Safety Instructions

## Caution

### **1. The product is provided for use in manufacturing industries.**

The product herein described is basically provided for peaceful use in manufacturing industries. If considering using the product in other industries, consult SMC beforehand and exchange specifications or a contract if necessary.  
If anything is unclear, contact your nearest sales branch.

## **Limited Warranty and Disclaimer/ Compliance Requirements**

The product used is subject to the following "Limited warranty and Disclaimer" and "Compliance Requirements".

Read and accept them before using the product.

### **Limited Warranty and Disclaimer**

#### **1. The warranty period of the product is 1 year in service or 1.5 years after the product is delivered, whichever is first.\*2)**

Also, the product may have specified durability, running distance or replacement parts. Please consult your nearest sales branch.

#### **2. For any failure or damage reported within the warranty period which is clearly our responsibility, a replacement product or necessary parts will be provided.**

This limited warranty applies only to our product independently, and not to any other damage incurred due to the failure of the product.

#### **3. Prior to using SMC products, please read and understand the warranty terms and disclaimers noted in the specified catalog for the particular products.**

\*2) Vacuum pads are excluded from this 1 year warranty.

A vacuum pad is a consumable part, so it is warranted for a year after it is delivered.

Also, even within the warranty period, the wear of a product due to the use of the vacuum pad or failure due to the deterioration of rubber material are not covered by the limited warranty.

### **Compliance Requirements**

#### **1. The use of SMC products with production equipment for the manufacture of weapons of mass destruction(WMD) or any other weapon is strictly prohibited.**

#### **2. The exports of SMC products or technology from one country to another are governed by the relevant security laws and regulation of the countries involved in the transaction. Prior to the shipment of a SMC product to another country, assure that all local rules governing that export are known and followed.**

## Caution

### **SMC products are not intended for use as instruments for legal metrology.**

Measurement instruments that SMC manufactures or sells have not been qualified by type approval tests relevant to the metrology (measurement) laws of each country.

Therefore, SMC products cannot be used for business or certification ordained by the metrology (measurement) laws of each country.

## ■ Explanation of Symbols

Symbol	Definition
	Things you must not do. Actual instructions are provided as a drawing or sentence close to this mark.
	Things you must do Actual instructions are provided as a drawing or sentence close to this mark.



## ■ Operator

<p>(1) This Operation Manual is intended for those who have knowledge of machinery using pneumatic equipment, and have sufficient knowledge of assembly, operation and maintenance of such equipment. Only those persons are allowed to perform assembly, operation and maintenance.</p> <p>(2) Read and understand this Operation Manual carefully before assembling, operating or providing maintenance to the product.</p>
---

## ■ Safety Instructions

Warning	
 Disassembly prohibited	Do not disassemble, modify (including the replacement of board) or repair. Otherwise, an injury or failure can result.
 Do not	Do not operate the product outside of the specifications. Do not use for flammable or harmful fluids. Fire, malfunction, or damage to the product can result. Please check the specifications before use.
 Do not	Do not use in an atmosphere containing flammable or explosive gases. Fire or an explosion can result. The product is not designed to be explosion proof.
 Do not	Do not use the product for flammable or highly permeable fluids. Fire, explosion, breakage or corrosion can result.
 Do not	Do not use the product in a place where static electricity is a problem. Otherwise failure or malfunction of the system can result.
 Instruction	If using the product in an interlocking circuit: - Provide a double interlocking system, for example a mechanical system. - Check the product for proper operation. Otherwise malfunction can result, causing an accident.
 Instruction	The following instructions must be followed during maintenance : - Turn off the power supply - Stop supplying fluid before maintenance. It may cause an injury.

## ⚠ Caution

 Do not touch	Do not touch the terminals and connectors while the power is on. Otherwise electric shock, malfunction or damage to the switch can result.
 Do not touch	Do not touch the piping joint or piping when hot fluid is used. It may lead to burn. Check that the piping is cooled down before touching it.
 Instruction	<ul style="list-style-type: none"> <li>■ After maintenance is complete, perform appropriate functional inspections and leak test.</li> <li>Stop operation if the equipment does not function properly or there is leakage of fluid.</li> <li>When leakage occurs from parts other than the piping, the product itself may be damaged.</li> <li>Cut off the power supply and stop the fluid supply.</li> <li>Do not apply fluid if the system is leaking.</li> <li>Safety cannot be assured in the case of unexpected malfunction.</li> </ul>

### ■ Handling Precautions

-Follow the instructions given below for selecting and handling.

- The instructions on design and selection (installation, wiring, environment, adjustment, operation, maintenance, etc.) described below must be followed.

\*Product specifications

- Use the specified voltage.

Otherwise failure or malfunction can result.

Insufficient supply voltage may not drive a load due to a voltage drop inside the product.

Check the operating voltage of the load before use.

Do not exceed the specified maximum allowable load.

This may cause damage or shorten the lifetime of the product.

Data stored by the product is not deleted, even if the power supply is cut off. (Write limit: 1000000 cycles, Data duration: 20 years after power off.)

- Confirm the pressure loss at the sensor according to the flow rate characteristics (pressure loss) graph before designing piping.

Confirm pressure loss of the sensor from the flow characteristics chart.

- Take care that pressure exceeding the specified range will not be applied due to water pulsation.

<Examples of measures for reducing water pulsation>

(1) Use a water pulsation resistant valve.

(2) Use elastic piping material such as rubber hose etc. and an accumulator to absorb impact pressure.

(3) Keep wiring length to a minimum.

- Use the product within the specified operating pressure and temperature range.

Withstand pressure is 2.0MPa. Withstand pressure depends on fluid temperature. Refer to the chart of the operating pressure range.

- Reserve a space for maintenance.

When designing an application, allow sufficient clearance for maintenance and inspection.

- Product handling

- \* Mounting

- Tighten to the specified tightening torque.

- If the tightening torque is exceeded, the mounting screws and brackets may be damaged. Insufficient torque can cause displacement of the product from its proper position and the looseness of the mounting screws.

- (Refer to Mounting and Installation (page 15 to 20).)

- If a commercially available switching power supply is used, be sure to ground the frame ground (FG) terminal.

- Do not use where the product is subjected to vibration or impact.

- Otherwise damage to the internal components may result, causing malfunction.

- Do not pull the lead wire forcefully, or lift the product by the lead wire.

- (Tensile strength 49 N or less)

- Hold the product body when handling to prevent damage, failure or malfunction.

- The product will be damaged, leading to failure and malfunction.

- When multiple sensors are used in parallel, the accuracy is deteriorated if they are mounted too closely together.

- For piping of the pressure switch, hold the piping with a wrench on the metal part of the product (piping attachment).

- Holding other parts of the product with a tool may damage the product.

- Specifically, make sure that the spanner does not damage the M12 connector.

- This will damage the connector.

- Any dust left in the piping should be flushed out by air before connecting the piping to the product.

- It will cause failure or malfunction.

- Refer to the flow direction of the fluid indicated on the product label for installation and piping.

- Avoid piping in which the piping size of the IN side of the switch changes suddenly.

- If the piping size is reduced suddenly, or there is a restrictor such as a valve on the IN side, the fluid velocity distribution in the piping will be disturbed, leading to improper measurement. Therefore, the above mentioned piping reduction or restrictor should be connected on the OUT side.

- If the OUT side is opened, or the flow rate is excessive, cavitations may be generated, which may result in improper measurement. As a measure against this, it is possible to reduce the cavitations by increasing the fluid pressure.

- Take action such as mounting an orifice on the OUT side of the switch, and confirm that there is no malfunction before handling.

- If the orifice of the OUT side is fully closed to operate the pump, the switch may malfunction due to the effect of pulsation (pressure fluctuation). Ensure that there is no malfunction before use.

- Do not insert metal wires or other foreign matter into the flow path.

- This can damage the sensor causing failure or malfunction.

- Never mount the product in a place that will be used as a scaffold during piping.

- The product may be damaged if excessive force is applied by stepping or climbing onto it.

## **- Design and install the product so that fluid always fills the detection passage.**

- 1, If the product is used when the detection passage is not filled, correct detection signal is not output from the electrodes, making correct measurement impossible.

For vertical mounting, apply fluid from the bottom to the top. Bubbles may be generated when applying fluid from the top to the bottom, leading to operation failure.

(There should not be a problem as long as the fluid passage is completely filled with fluid)

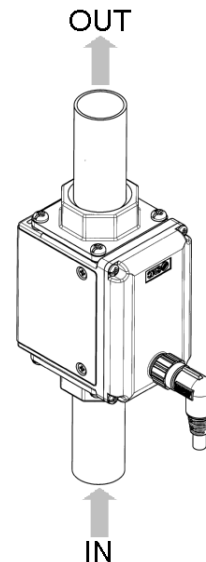

2. When the product is mounted vertically, place the display perpendicular to the floor (to place the electrodes on the right and the left) to prevent bubbles from occurring.

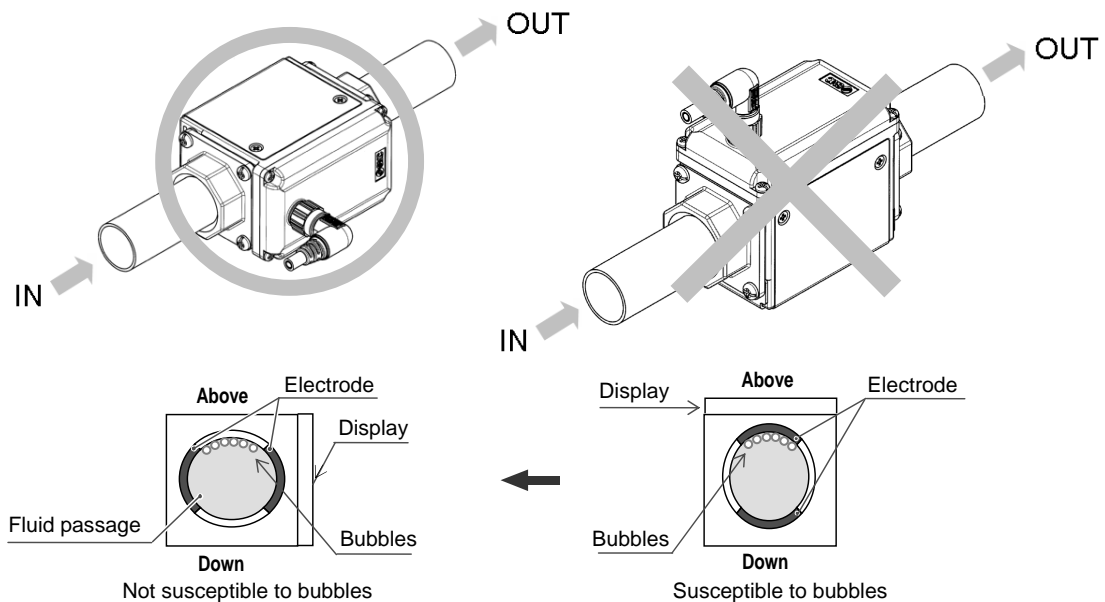



\* Wiring (Including connecting/disconnecting of the connectors)

Do not pull hard on the lead wire, or lift the product by holding the lead wires (Tensile strength 49 N or less). Especially never lift the product equipped with fitting and piping by holding the lead wires.

Damage to the connector, circuit board, cover or internal components may result, causing failure or malfunction.

- Avoid repeatedly bending, stretching or applying a heavy object or force to the lead wire.

Repetitive bending stress or tensile stress can cause the sheath of the wire to peel off, or breakage of the wire.

If the lead wire can move, fix it near the body of the product.

The recommended bend radius of the lead wire is 6 times the outside diameter of the sheath, or 33 times the outside diameter of the insulation material, whichever is larger.

Replace the damaged lead wire with a new one.

- Wire correctly.

Incorrect wiring can cause malfunction or damage the product.

- Do not perform wiring while the power is on.

Otherwise damage to the internal components may result, causing malfunction.

- Do not route wires and cables together with power or high voltage cables.

Route the wires of the product separately from power or high voltage cables to prevent noise and surge from entering the product.

- Confirm proper insulation of wiring.

Poor insulation (interference with other circuits, poor insulation between terminals etc.) can apply excessive voltage or current to the product causing damage.

- Design the system to prevent reverse current when the product is performing an operational check.

Depending on the circuit used, insulation may not be maintained when operation is forced, allowing reverse current to flow, which can cause malfunction and damage to the product.

- Keep wiring to a minimum to prevent interference from electromagnetic noise and surge voltage.

Do not use a cable longer than 10 m.

Wire the DC (-) line (blue) as close as possible to the power supply.

- When analogue output is used, install a noise filter (line noise filter, ferrite element, etc.) between the switch-mode power supply and the product.

#### \*Operating environment

- Do not use the product in an environment where the product is constantly exposed to water splashes.  
Otherwise failure or malfunction can result. Take measures such as using a cover.
- Do not use in an environment where the product could be exposed to corrosive gas or liquids.  
Otherwise damage to the internal parts can result, causing malfunction.
- Do not use the product in a place where the product could be splashed by oil or chemicals.  
If the product is to be used in an environment containing oils or chemicals such as coolant or cleaning solvent, even for a short time, it may be adversely affected (damage, malfunction, or hardening of the lead wires).
- Do not use in an area where surges are generated.  
When there are machines or equipment that generate large surges near the product (magnetic type lifter, high frequency inductive furnace, motor, etc.), this can result in deterioration and damage of the internal elements. Take measures against the surge sources, and prevent the lines from coming into close contact.
- Do not use a load which generates surge voltage.  
When a surge-generating load such as a relay or solenoid is directly driven, use the product with a surge absorbing element built-in.
- The product is CE marked, but not immune to lightning strikes. Take measures against lightning strikes in the system.
- Mount the product in a location that is not affected by vibration or impact.  
Failure or malfunction may result.
- Do not use the product in the presence of a magnetic field.  
Malfunction can result.
- Do not let foreign matter, such as wire debris, get inside the product.
  - In order to avoid failure and malfunction, do not let foreign matter, such as wire debris, get inside the product.
- Do not use the product in an environment that is exposed to temperature cycle.  
Heat cycles other than ordinary changes in temperature can adversely affect the internal components of the product.
- Do not expose the product to direct sunlight.  
If using in a location directly exposed to sunlight, protect the product from the sunlight.  
Failure or malfunction may result.
- Keep within the specified operating fluid and ambient temperature range.  
The operating fluid temperature range is 0 to 85 °C, and ambient temperature range is 0 to 50°C.  
If the fluid freezes, it may cause damage and malfunction of the switch, so please take measures to prevent freezing.  
If the temperature of the fluid is lower than the ambient temperature, condensation will be generated which may damage the product or cause malfunction.  
Protection against freezing is necessary.  
Avoid abrupt temperature changes even within the specified temperature range.  
Failure or malfunction may result.
- Do not operate close to a heat source, or in a location exposed to radiant heat.  
Insufficient air quality may cause operation failure.

#### \* Adjustment and Operation

- Connect the load before turning the power supply on.  
If the power supply is turned on with no load, over current may occur, causing the product to break instantly.
- Do not short-circuit the load.  
Although error is displayed when the product load has a short circuit, generated over current may lead to the damage of the product.
- Supply power under no flow conditions,.
- There will be a drift on the display / analogue output of approx 2 to 3% for 5 minutes after the power supply is turned on.
- The product doesn't produce and output signal for 3 seconds after the power is supplied.

#### \* Maintenance

- Confirm safety by turning off the power supply and stopping the flow before performing maintenance.  
There is a risk of unexpected malfunction.
- Perform regular maintenance and inspections.  
There is a risk of unexpected failure of components due to the malfunction of equipment and machinery.
- Do not use solvents such as benzene, thinner etc. to clean the product.  
This may damage the surface of the body or erase the markings on the body.  
Use a soft cloth to remove stains.  
For heavy stains, use a cloth soaked with diluted neutral detergent and fully squeezed, then wipe up the stains again with a dry cloth.

## Model Indication and How to Order

LFE□□□□□

Body size (Flow rate range)

Symbol	Content
1	0.5~ 20L/min
2	2.5~100L/min
3	5~200L/min

Option

Symbol	Lead wire	Bracket
Nil	Yes	-
1	-	-
2	Yes	Yes
3	-	Yes

Output Specifications

Symbol	OUT2
J	Analogue 1 to 5V
K	Analogue 4 to 20mA

Piping port size

Symbol	Port size	Rated flow range		
		1	2	3
3	3/8	Yes	-	-
4	1/2	Yes	-	-
6	3/4	-	Yes	-
8	1	-	-	Yes

Thread type

Symbol	Description
Nil	Rc
N	NPT
F	G

### Lead wire

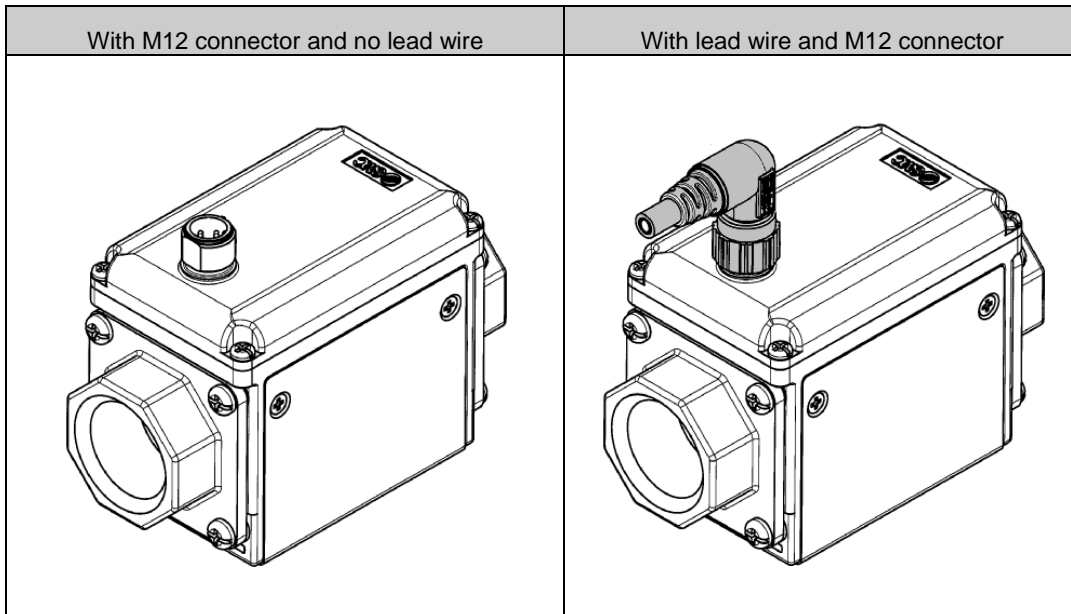

### Bracket

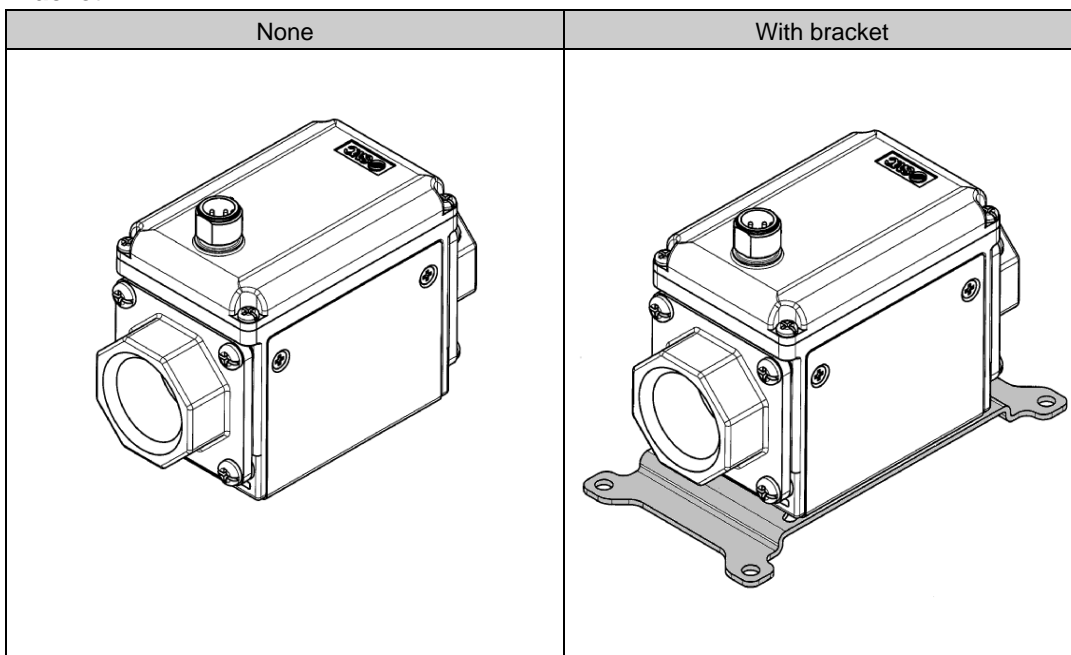

### Accessories/ Part numbers

If an accessory is required, order using the following part number.

Option	Part number	Remarks	Weight
With lead wire and M12 connector	LFE-1-A3	Lead wire length: 3 m	Approx. 175 g
Bracket	LFE-1-D	Tapping screw 3 x 10, 4 pcs.	Approx. 45 g
	LFE-2-D	Tapping screw 3 x 10, 4 pcs.	Approx. 70 g
	LFE-3-D	Tapping screw 3 x 10, 4 pcs.	Approx. 70 g

## Summary of product parts

### Body

With lead wire and M12 connector (4 pins)

(Options)

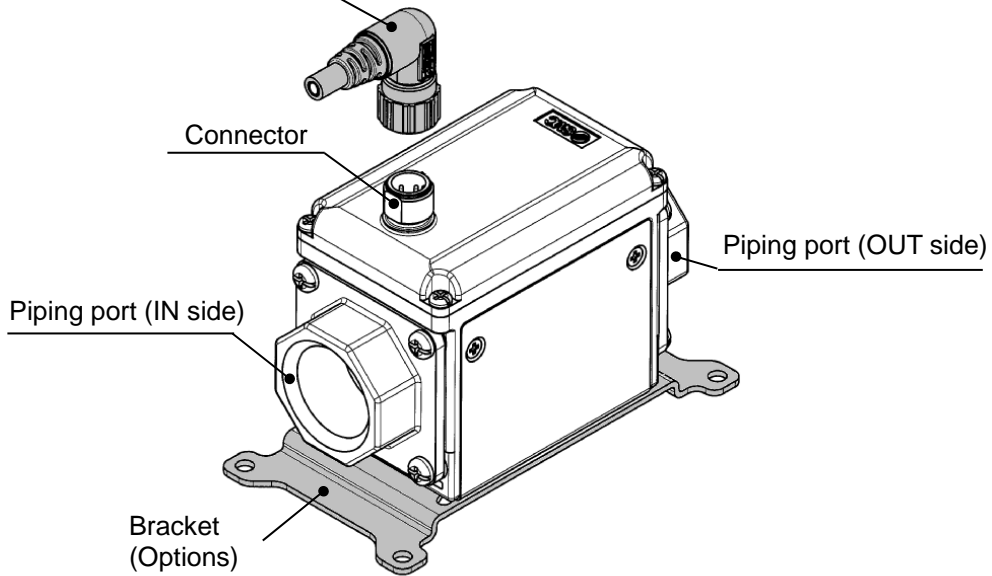

Description	Function
Connector	The part to which lead wires are connected.
With lead wire and M12 connector	This is a cable that supplies power to the product and receives output.
Piping port	For piping connections.
Bracket	This is a mounting bracket used to install the product.

■ Definition and terminology

	Term	Meaning
A	Ambient temperature range	Ambient temperature range in which the product can operate.
	Analogue output	Outputs a value proportional to the flow rate. When the analogue output is in the range 1 to 5V, it will vary between 1 to 5V according to the rate of flow. The same for analogue output of 4 to -20 mA.
	Attachment	The metal part of both sides of the product to which piping is connected.
C	Cavitation	A phenomenon that may occur in a fluid moving at a high speed. In the areas within the fluid where the pressure is low, vapor bubbles form and then rapidly collapse. If cavitation is present for a prolonged period, exposed surfaces will be damaged; this is referred to as cavitation damage or, erosion.
E	Electric conductivity	The electric conductivity is a ratio which shows how easily the electricity flows. The unit is [S/cm] (siemens/centimeter). The lower the electric conductivity, the more difficult the electricity flows in the fluid. On the contrary, the higher the electric conductivity, the easier the electricity flows in the fluid. The minimum electrical conductivity for fluids for this sensor is 5uS/cm. Conductivity of tap water is 100 to 200uS/cm.
F	F.S.(full span/full scale)	This means "full span" or "full scale", and indicates varied analogue output range at rated value. For example, when analogue output is 1 to 5 V, F.S.=5[V] – 1[V]=4[V]. (Reference: 1%F.S. = 4[V] × 1% = 0.04[V])
I	Instantaneous flow	The flow passing per unit of time. If it is 10 L/min, there is a flow of 10 L passing through the device in 1 minute.
M	Measured fluid	The fluid(s) that the product can measure.
O	Operating fluid temperature	Range of fluid temperature that can be measured by the product.
	Operating pressure range	The pressure range in which the product can be used.
P	Part in contact with fluid (wetted part)	A part that comes into physical contact with the fluid.
	Pressure characteristics	Indicates the change in the display value and analogue output when fluid pressure changes.
R	Rated flow range	The flow range within which the product will meet all published specifications.
	Rated pressure range	The pressure range that satisfies the specifications.
	Repeatability	Reproducibility of the display or analogue output value, when the measured quantity is repeatedly increased and decreased.
	Response time	Time from when the target flow is applied until the flow reaches 63% of the set value.
T	Temperature characteristics	Indicates the change in the display value and analogue output caused by ambient temperature or fluid temperature changes.
W	Water hammer	Water hammer is a pressure surge due to pressure spread. It occurs when a fluid in motion is forced to stop or change direction when equipment, such as valve is opened/closed.
	Withstand pressure	Burst pressure at which the product is electrically or mechanically damaged.

## Mounting and Installation

### Installation

- Use the product within the specified operating pressure and temperature range.

Withstand pressure is 2MPa.

Withstand pressure depends on fluid temperature. Refer to the chart of the operating pressure range.

### Mounting

- Never mount the switch in a location that will be used as a scaffold.

- Mount the product so that the fluid flows in the direction indicated by the arrow on the side of the body.

- Check the flow characteristics data for pressure loss and the straight inlet pipe length effect on accuracy (page 25), to determine inlet piping requirements.

- Do not suddenly reduce the piping diameter.

- Piping port and the metal part of the body are grounded to DC(-)/blue line.

Do not use the power supply with positive ground.

- When multiple sensors are used in parallel, install them outside of the area shown below. (Uninstallable area)

If the product is mounted in the area where installation is prohibited, the accuracy will decrease.

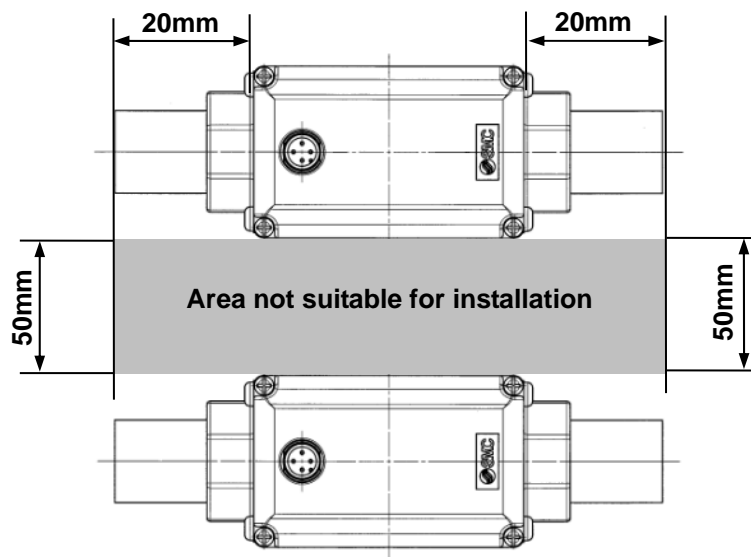



## ■ Installation

### Bracket mounting

Fix the bracket using the mounting screws (Equivalent to M4: 4 pcs.).

Bracket thickness is approx. 1.6mm

Refer to the outline dimension drawing (page 29) for mounting hole sizes.

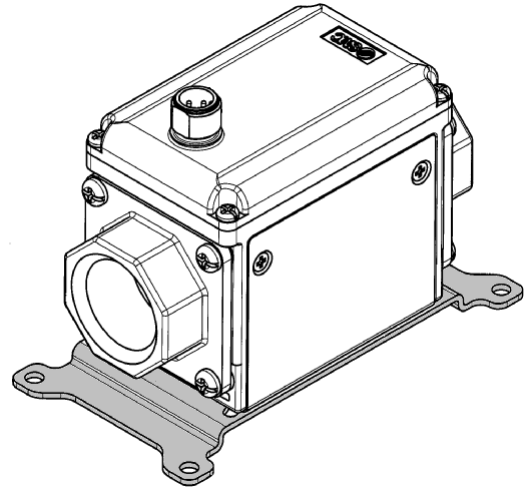

### Direct mounting

Mount the product with the screw stated below.

Thread type	Nominal thread size	Tightening torque
Tapping screw	3	0.7 to 0.8 Nm

Refer to the outer dimensional drawing (page 29) for the diameter and depth of the mounting screw holes.

- If you are installing directly, choose the self tapping screw screw-in depth is to 8mm.
- The self tapping screws cannot be reused.

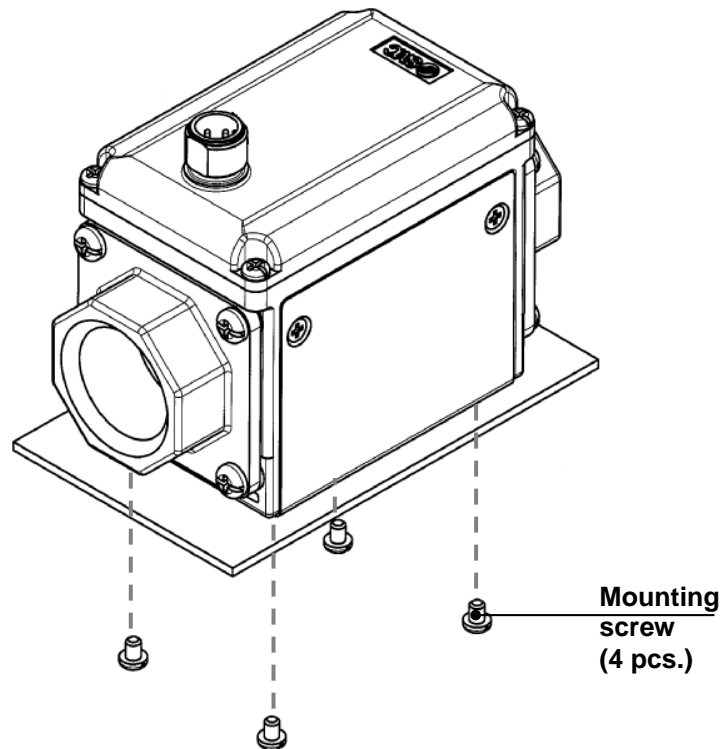

■ Piping method

When connecting the piping to the product, do not rotate the switch. Apply a spanner to the metal part of the piping port to turn the fitting.”

Using a spanner on other parts may damage the product.

Specifically, make sure that the tool does not damage the M12 connector.

This will damage the connector.

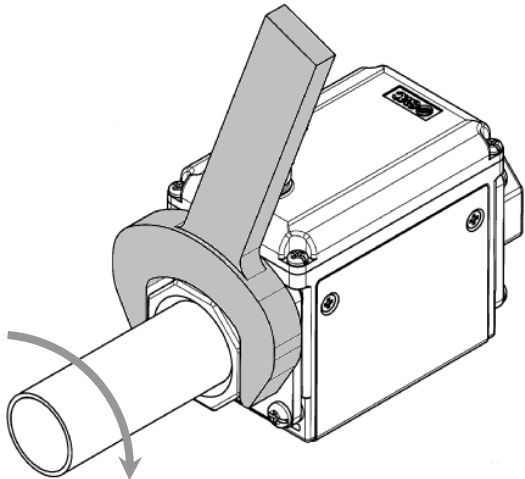

Width across flats of attachment

3/8	24 mm
1/2	28 mm
3/4	35 mm
1	41 mm

- Ensure that the piping is tightened to the required torque.

The tightening torque for connection threads is shown in the table below.

Nominal thread size	Appropriate tightening torque
Rc(NPT)3/8	22 to 24 Nm
Rc(NPT)1/2	28 to 30 Nm
Rc(NPT)3/4	28 to 30 Nm
Rc(NPT)1	36 to 38 Nm

If the tightening torque is exceeded, the product can be damaged. If the tightening torque is insufficient, the mounting screws and brackets may become loose.

The product body is made of resin. Do not apply direct stress, vibration or impact during piping to avoid malfunction, damage or water leakage. Never mount the product in a location that will be used as a scaffold.

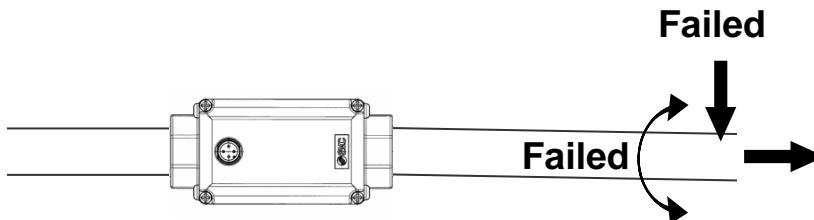

-Affix the piping as close to the product as possible (both before and after the product) to avoid direct stress, vibration or impact.

If the stress, vibration or impact cannot be reduced, affix the product at multiple locations.

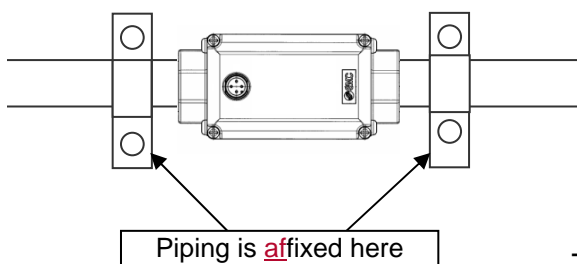

Non-flexible piping materials such as steel piping will be subject to excessive moment load, vibration and impact from the piping side, so use a flexible tube for intermediate connection. Misaligned piping may apply long-term load after piping, causing malfunction, damage, or water leakage.

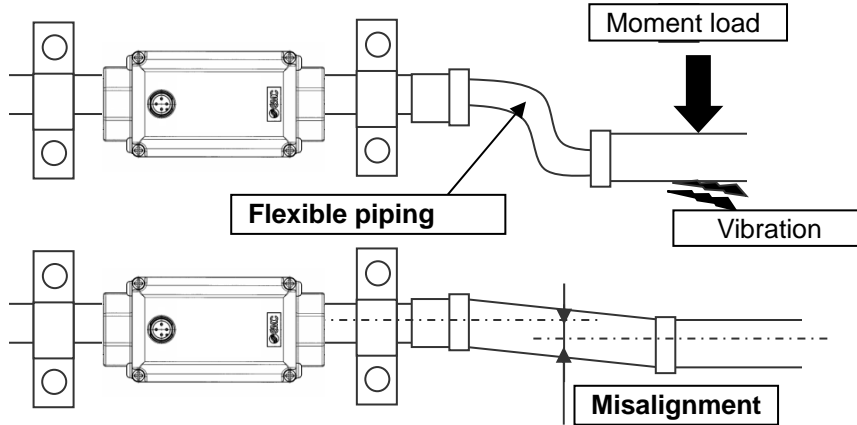

If one-touch fitting is used, hold the fitting **by** hand so that the load for mounting and removing the tube will not be applied to the product.

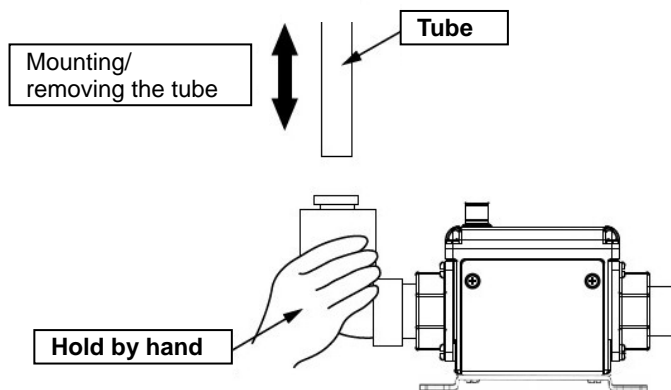

The IN side straight piping length shall be a minimum of 5 times (5D) the piping size to achieve a stable measurement. (page 26)

Avoid any sealing tape getting inside the piping.  
 - Ensure that there is no leakage from loose piping.

■ Wiring

**Connector**

Attaching/detaching the connector should be done while the power supply is turned off.

Use a separate route for the product wiring and any power or high voltage wiring.

If wires and cables are routed together with power or high voltage cables, -malfunction may result due to noise.

If a commercially available switching power supply is used, be sure to ground the frame ground (FG) terminal. If the product is connected to the commercially available switching power supply, switching noise will be superimposed and the product specifications will not be satisfied. In that case, insert a noise filter such as a line noise filter/ ferrite between the switching power supplies or change the switching power supply to the series power supply.

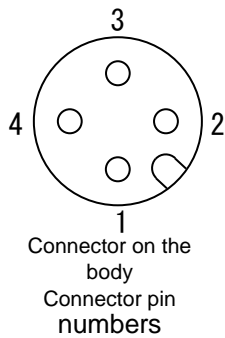

1	DC polar indication
2	OUT2
3	DC (-)
4	OUT1

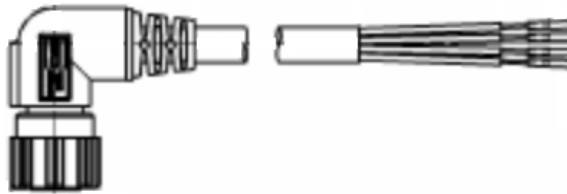
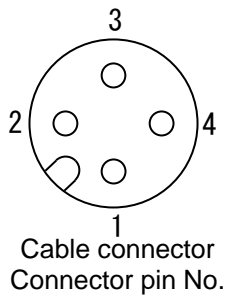

1	DC (+): Brown
2	OUT2: White
3	DC (-): Blue
4	OUT1: Black

\*: When using the lead wire with M12 connector included with the LFE series.

## Internal Circuit and Wiring examples

Analogue output (voltage) type

LFE□J□□□

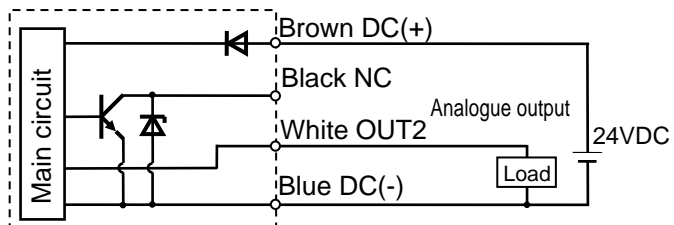

Analogue output 1 to 5 V  
Output impedance 1 k $\Omega$

Analogue output (current) type

LFE□K□□□

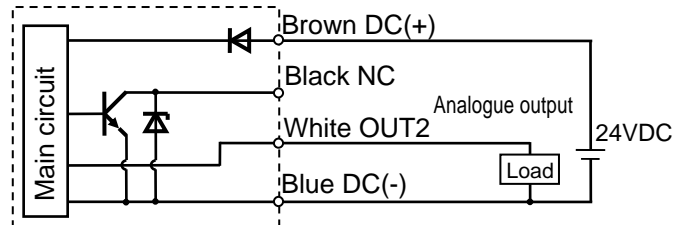

Analogue output 4 to 20mA  
Max. load impedance 600  $\Omega$

## Maintenance and Inspection

### **How to reset the product after a power cut or when the power has been unexpectedly removed**

The settings of the product are retained from before the power cut or de-energizing.

The output condition also recovers to that before power cut or de-energizing, but may change depending on the operating environment. Therefore, check the safety of the whole installation before operating the product.

## Troubleshooting

### Troubleshooting

Applicable Flow switch: LFE series

If an operation failure of the flow switch occurs, please confirm the cause of failure from the flow chart below. If a cause applicable to the failure cannot be identified and normal operation can be recovered by replacement with a new flow switch, this indicates that the flow switch itself was faulty. The damage to the Flow switch may have been caused by operating environment (network construction, etc.). Consult with SMC separately to obtain countermeasures.

### Troubleshooting list

Fault	Problem	Possible cause	Investigation method	Countermeasure
Output signal is abnormal	No output	Incorrect wiring	Check that the brown line (DC+) and the blue line DC(-) are connected to the black line (OUT1) and the white line (OUT2) respectively .	Check and correct the wiring.
		Loose connector	Check the connection of the connector.	Connect the connectors.
	Unstable output	Foreign matters in the sensor fluid path.	Check the presence of foreign matter	Remove foreign matter.
		The piping is connected in the wrong direction.	Confirm if the mounting direction is aligned with the flow direction.	Align the direction of the mounting and flow.
		Water supply shortage	Confirm whether the fluid path is full.	Fill the fluid path with fluid.
		There are bubbles in the fluid path.	Check there are no air bubbles in the tank.	Change the layout of piping to prevent air bubbles from occurring in the fluid path.
		Pulsation in the flow.	Check if there is supply pressure fluctuation or pressure pulsation due to the characteristics of the compressor or pump acting as the pressure source.	Change to a pump with less pulsation. Install a tank to reduce the pressure fluctuation. Change to elastic piping such as rubber hoses.
		Leakage occurs	Check for air leakage due to insufficient tightening of the screw of the piping and/or improper sealing.	Reconnect the pipes with the specified tightening torque and rewrap the sealant tape.
		Noise	Check if there is a power line or a high voltage line which generates noise in the wiring route.	Route wiring separately from power lines and high voltage lines.

## Specifications

### ■ Specifications

#### Specifications

Model		LFE1	LFE2	LFE3
Applicable Fluids <sup>*1</sup>		Conductive fluids which do not corrode the fluid contact materials. <sup>*1</sup>		
Applicable fluid conductivity <sup>*1</sup>		5μS/cm or more (micro Siemens/cm)		
Detecting method		Electro static capacity		
Ground <sup>*5</sup>		Negative ground		
Fluid temperature <sup>*2</sup>		0 to 85 °C (No condensation or freezing)		
Repeatability		Analogue output: +/-1.5%F.S.		
Temperature characteristics	Ambient temperature characteristics	+/-5%F.S.(25 °C reference)		
	Fluid temperature characteristic	+/-5%F.S.(25 °C reference)		
Operating pressure range <sup>*2</sup>		0 to 1 MPa		
Withstand pressure <sup>*2</sup>		2 MPa		
Analogue output	Response <sup>*3</sup> time	0.5 s		
	Voltage output	Output voltage: 1 to 5 V, Output impedance: 1 kΩ min.		
	Current output	Output current : 4 to 20 mA Max. load impedance 600 Ω		
Power supply voltage		24 VDC +/-10%		
Current consumption		42mA or less (Load current is not included)		
Environmental	Enclosure	IP65		
	Operating temperature range	0 to 50°C (No condensation or freezing)		
	Operating humidity range	Operation, Storage: 35 to 85%RH (No condensation)		
Standards		CE marking, RoHS		
Material of fluid contact parts		PPS, FKM, C37		
Port size		3/8(10 A)	1/2(15 A)	3/4(20 A) 1(25 A)
Weight(Body) <sup>*4</sup>		Approx. 335 g	Approx. 395 g	Approx. 515g Approx. 675 g

\*1: Refer to page 24 [Applicable fluids list].

\*2: When fluids with high temperature are used, the available pressure range will be reduced. (See [Operating pressure range] on page 27 for details.

\*3: The response time is when the set value is 63% in relation to the step input.

\*4: When options are used, add the weight of the option parts.

\*5: Piping port of the body is grounded to DC(-)/blue line. A power supply with positive ground cannot be used.



■ Applicable Fluids

**Applicable fluid list**

Substance description	Judgment	Remarks
Water	○	Conductivity of tap water: 100 to 200 $\mu$ S/cm
Deionized water	X	The electric conductivity is too low.
Water base coolant	○	When the ratio of water is 50% or more.
Oil	X	The electric conductivity is too low.
Oil base coolant	X	The electric conductivity is too low.
Sea water	X	Corrosive to the product.
Ethylene glycol	X	The electric conductivity is too low.
Ethanol	X	The electric conductivity is too low.
Methanol	X	The electric conductivity is too low.
Chloride water (Hypochlorous acid)	X	Corrosive to the product.

\*: The applicable fluid list should be used as a guide.

(1) Operate fluids with electric conductivity of 5 $\mu$ S/cm or more.

Note that this product can not be used for fluids with low conductivity.

This product cannot be used for fluids that do not conduct electricity such as De-ionized water and oil.

The electric conductivity is a ratio which shows how easily the electricity flows.

(2) If insulating material gets stuck inside of the piping, it may cause an error.

Remove the foreign material stuck inside of the piping with a brush for washing test tubes so that internal rubber piping will not be damaged.

(3) If conductive materials such as metal get stuck to the interior surface in the piping, the switch may malfunction.

Remove the foreign material as mentioned above.

(4) If stray electrical currents are flowing through the fluid to be measured, the switch may malfunction.

Beware that electrical leakage currents may be generated by equipment around the flow sensor such as pumps, valves and metal piping when this equipment is at different electrical potentials in relation to earth ground.

**Cable with M12 connector lead wire (LFE-1-A3)**

Item		Specifications
Conductor	Nominal cross section	AWG21
	O.D.	Approx. 0.9 mm
Insulator	Material	Lead free heat resistant PVC
	O.D.	Approx. 1.7 mm
	Colours	Brown, White, Black, Blue
Sheath	Material	Lead free heat and oil resistant PVC
Finished O.D.		$\Phi$ 6

■ Characteristics Chart

**Flow characteristics (Pressure loss)**

LFE1

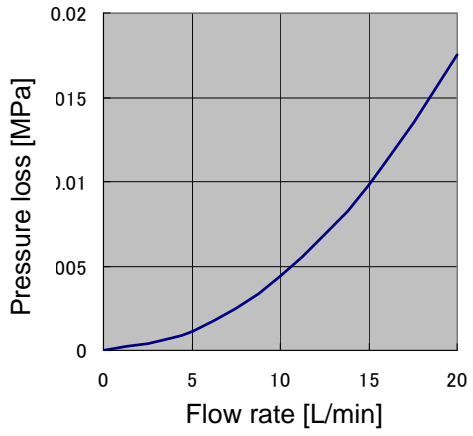

LFE2

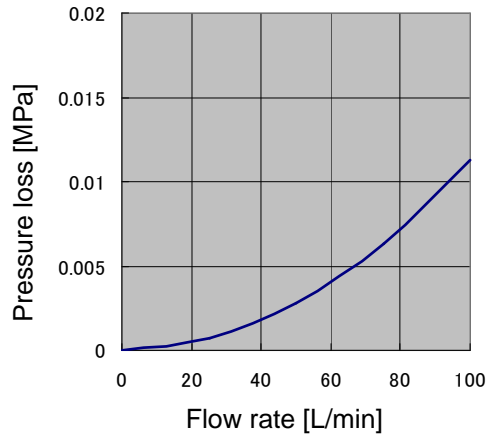

LFE3

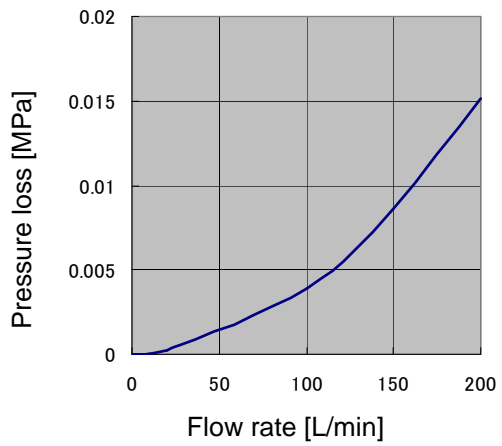

### IN side straight pipe length (reference value)

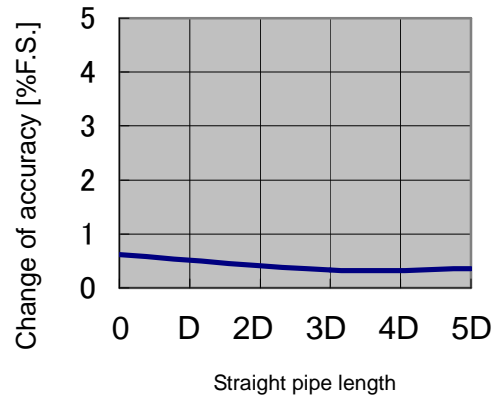
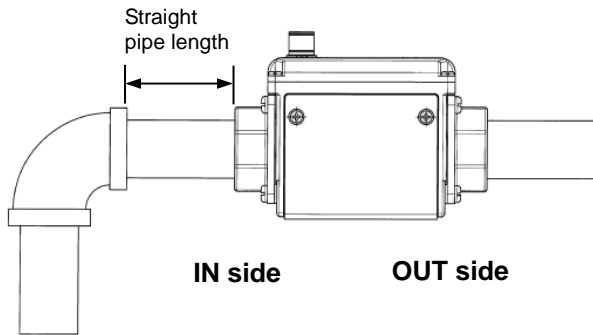

[Measurement condition]	[Port size]
Measurement: Tap water	LFE1 : 3/8 inch
Pressure: 0.2 MPa	LFE2 : 3/4 inch
	LFE3 : 1 inch

The smaller the piping size, the more the product is affected by the length of straight piping. The straight piping length shall be a minimum of 5 times (5D) the piping size to achieve a stable measurement.

Model	Straight pipe length (mm)	
	D	5 D
LFE1	11	55
LFE2	21	105
LFE3	27	135

### ■ Stability

Fluctuation of the display and the analogue output can be reduced by lengthening the response time setting.

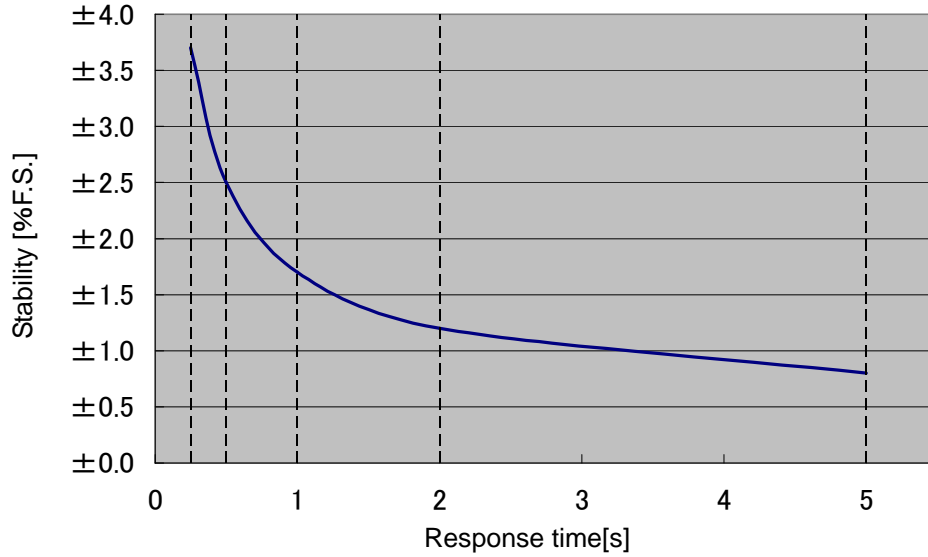

### ■ Operating pressure range

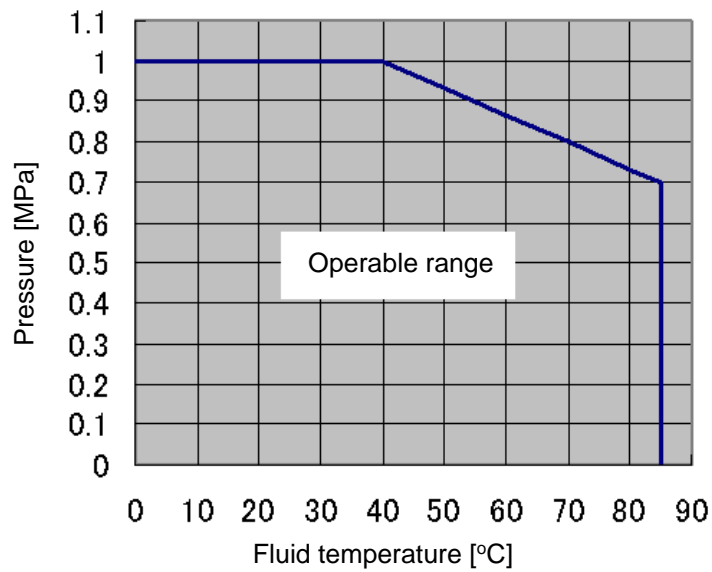

When high temperature fluids are used, the operating pressure range will be reduced. Operate within the range given above.

The proof pressure is double the operating pressure range.

■ Analogue output

**Flow rate/Analogue output**

	A	B	C
Voltage output	1 V	1.1 V	5 V
Current output	4 mA	4.4 mA	20 mA

Model	Rated flow rate[L/min]	
	Minimum	Maximum
LFE1	0.5	20
LFE2	2.5	100
LFE3	5	200

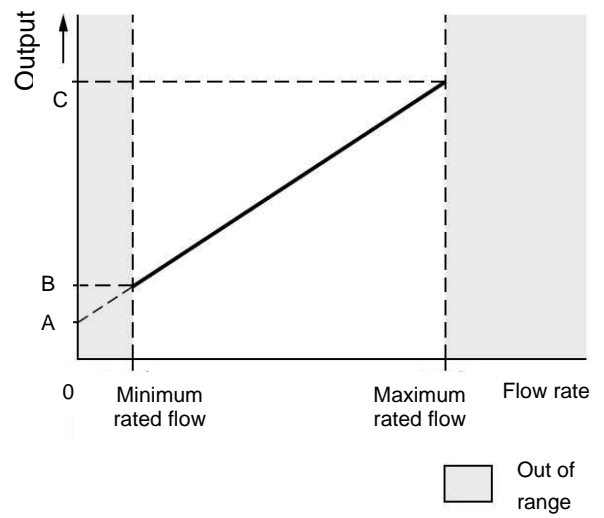

■ Dimensions

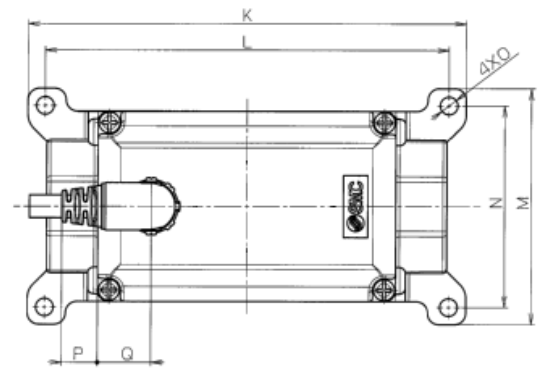
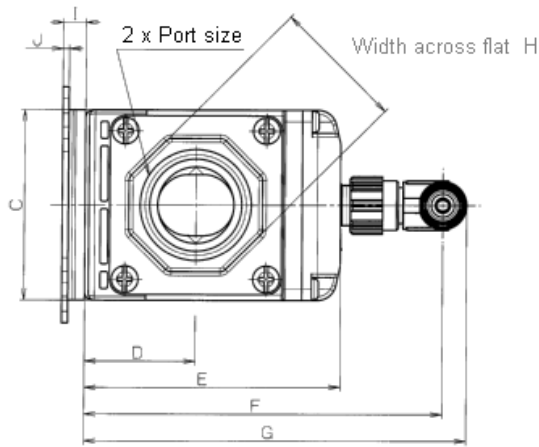

Note) The electrical entry for lead wire with M12 connector does not rotate and is limited to only one entry direction.

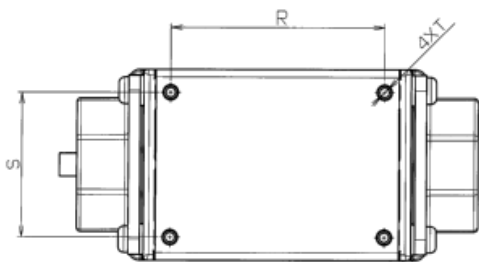

Without bracket ( Bottom view )

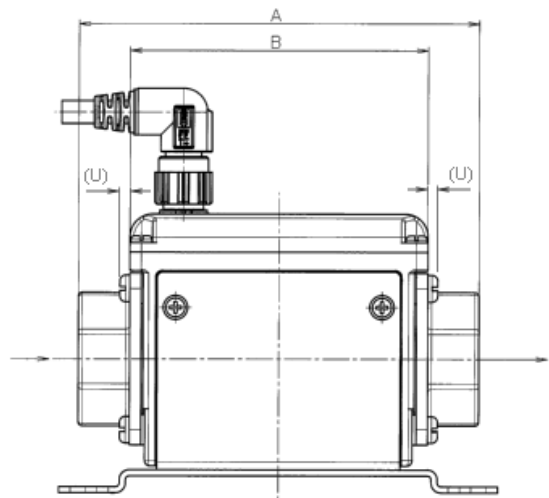

Bracket thickness is approx. 1.6mm

Model	Piping port size	A	B	C	D	E	F	G	H	I	J	K	L
LFE1□3□□	3/8	90	73	40	23.5	56	83	89	24	6	1.6	96	87
LFE1□4□□	1/2	104	73	40	23.5	56	83	89	28	6	1.6	96	87
LFE2□6□□	3/4	105	78	50	29	67	94	100	35	6	1.6	115	106
LFE3□8□□	1	120	90	55	32	73	100	106	41	6	1.6	115	106

Model	M	N	O	P	Q	R	S	T	U	Bracket weight
LFE1□3□□	48	39	4.6	12	11.5	52	28	2.5 depth 8.5	2	Approx. 45g
LFE1□4□□	48	39	4.6	12	11.5	52	28	2.5 depth 8.5	2	Approx. 45g
LFE2□6□□	62	53	4.6	9.5	14	56	38	2.5 depth 8.5	2.6	Approx. 70g
LFE3□8□□	62	53	4.6	3.5	20	68	43	2.5 depth 8.5	2.6	Approx. 70g

Dimension of the cable with M12 connector lead wire (LFE-1-A3)

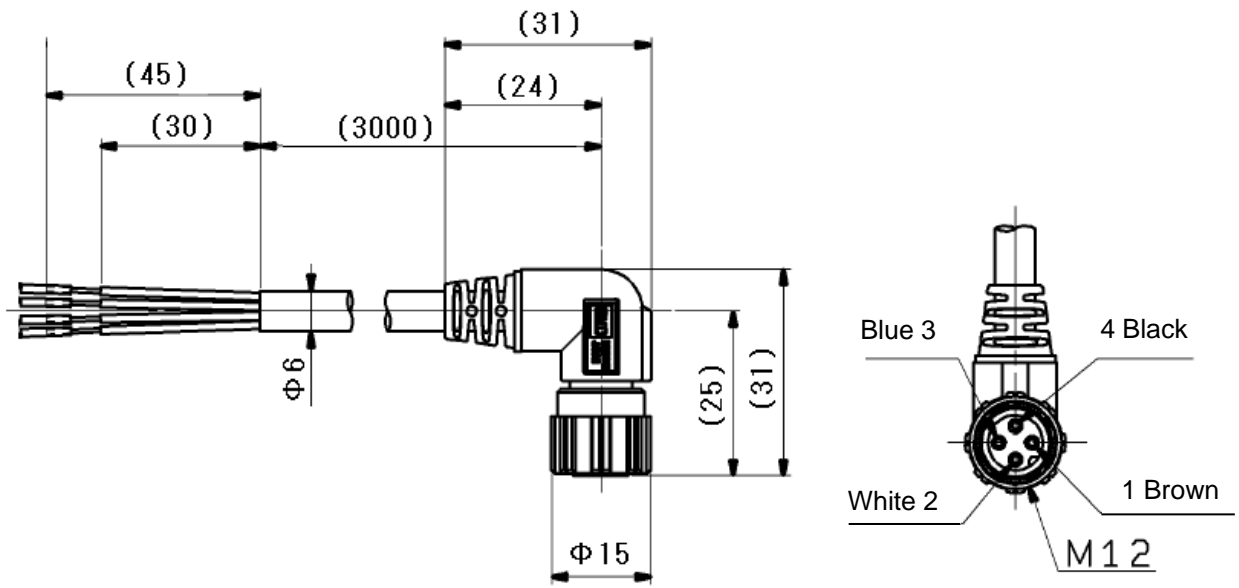

Revision
A : Contents revised in several places.
B : Contents revised in several places.
C : Contents revised in several places.
D : Contents revised in several places.
E : Contents revised in several places.
F : Contents revised in several places.

## SMC Corporation

4-14-1, Sotokanda, Chiyoda-ku, Tokyo 101-0021 JAPAN

Tel: + 81 3 5207 8249 Fax: +81 3 5298 5362

URL <https://www.smcworld.com>

---

Note: Specifications are subject to change without prior notice and any obligation on the part of the manufacturer.

© 2020 SMC Corporation All Rights Reserved