

PNEUMATIC GRIPPER "AIR CHUCK"  
MH SERIES  
INSTRUCTION MANUAL

HOW TO ORDER

MH P 20 D - Y59A

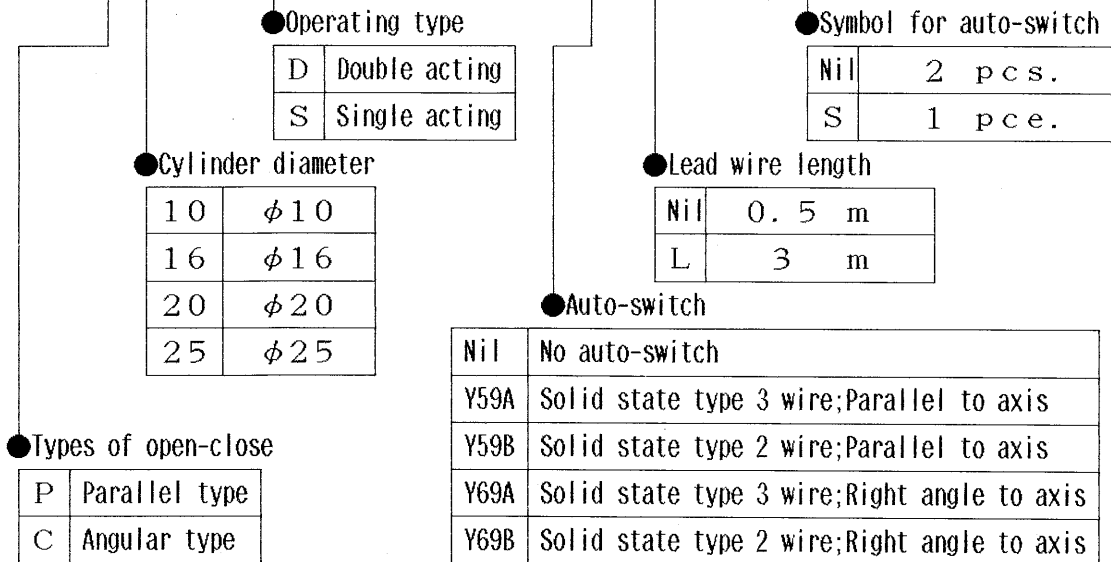

= INDEX =

1. Mounting style of Air Chuck. . . . .	Page 1
2. Mounting procedure of auto-switch. . . . .	Page 2
3. Piping. . . . .	Page 2
4. Installation adjustment of Air Chuck. . . . .	Page 3
5. Gripping point. . . . .	Page 5
6. Effective gripping force for parallel type gripper. . . . .	Page 6
7. Effective gripping force for angular type gripper. . . . .	Page 7

### 1. Mounting style of Air Chuck.

MH series Air Chuck can be mounted from 3 directions.

Appropriate direction can be selected to suit intended machinery or workpiece.

#### ① To mount direct axis type (body tap)

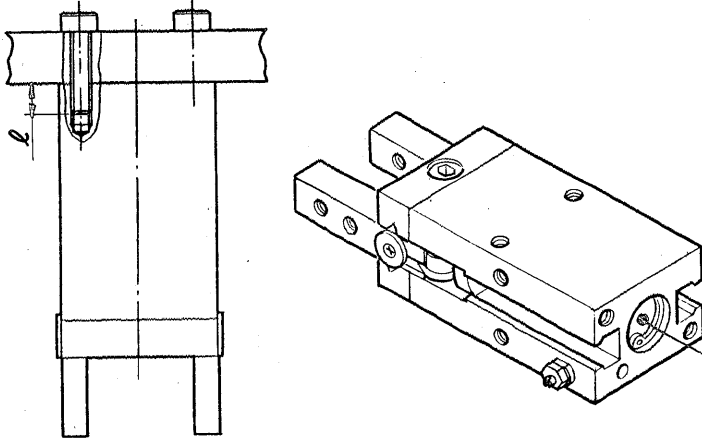

Model	using bolt	MAX. tightening torque kgf·cm	MAX. length of engagement; ℓ mm
MHP10, MHC10	M3x0.5	9	6
MHP16, MHC16	M4x0.7	21	8
MHP20, MHC20	M5x0.8	44	10
MHP25, MHC25	M6x 1	74	12

• Holes at end of body can be used for positioning.

Model	Hole dia.	Hole depth
MHP10, MHC10	Φ11H9 <sup>+0.043</sup> <sub>0</sub>	1.5
MHP16, MHC16	Φ17H9 <sup>+0.043</sup> <sub>0</sub>	1.5
MHP20, MHC20	Φ21H9 <sup>+0.052</sup> <sub>0</sub>	1.5
MHP25, MHC25	Φ26H9 <sup>+0.052</sup> <sub>0</sub>	1.5

#### ② Side mounting type (body tap, body through hole)

Body tap use

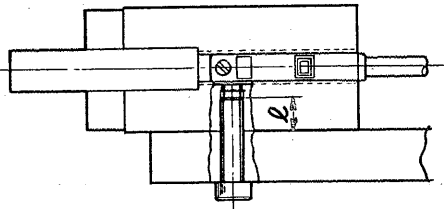

• In case, body tap is used.

Model	using bolt	MAX. tightening torque kgf·cm	MAX. length of engagement; ℓ mm
MHP10, MHC10	M3x0.5	7	5
MHP16, MHC16	M4x0.7	21	8
MHP20, MHC20	M5x0.8	44	10
MHP25, MHC25	M6x 1	74	12

Body through hole use

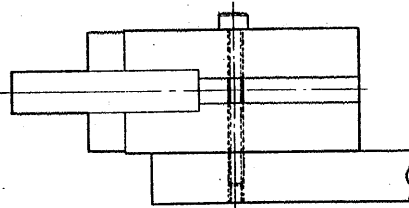

• In case, body through hole is used.

Model	using bolt	MAX. tightening torque kgf·cm
MHP10, MHC10	M2.5x0.45	5
MHP16, MHC16	M 3 x0.5	9
MHP20, MHC20	M 4 x0.7	21
MHP25, MHC25	M 5 x0.8	44

Note) When auto-switch is desired, only body tap type can be used. Care should be taken not to push main body of the switch by end of bolt, length of engagement; ℓ should be no more than figures stated in table as shown.

Model	MAX. length of engagement; ℓ mm
MHP10, MHC10	5
MHP16, MHC16	8
MHP20, MHC20	10
MHP25, MHC25	12

#### ③ Vertical mounting type (body tap)

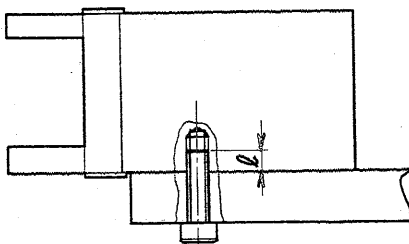

Model	using bolt	MAX. tightening torque kgf·cm	MAX. length of engagement; ℓ mm
MHP10, MHC10	M3x0.5	9	6
MHP16, MHC16	M4x0.7	16	6.5
MHP20, MHC20	M5x0.8	34	8
MHP25, MHC25	M6x 1	60	10

## 2. Mounting procedure of auto-switch.

To mount auto-switch, insert auto-switch into mounting groove of Air Chuck as shown in lower illustration. After mounting position is determined, secure by tightening fitting screw provided.

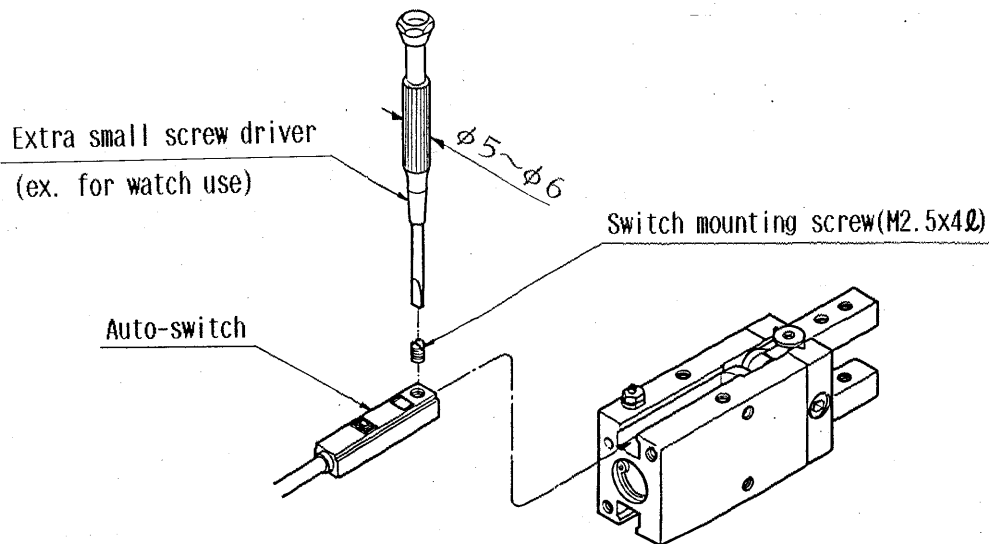

Note) To tighten auto-switch fitting screw, use extra small screw driver of grip dia.

approx. 5—6mm. Advised tightening torque is approx. 0.5—1kgf·cm. When touch feeling is obtained, rotate 90° to reach the required torque.

## 3. Piping.

Double acting type.

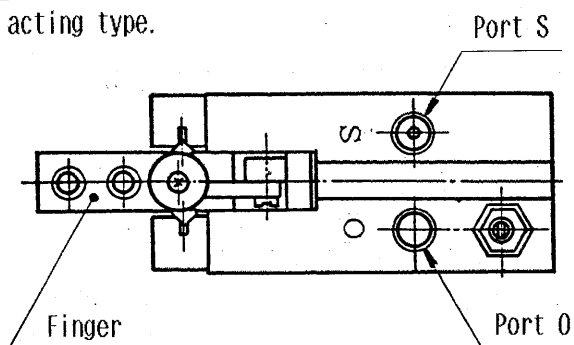

Single acting type.

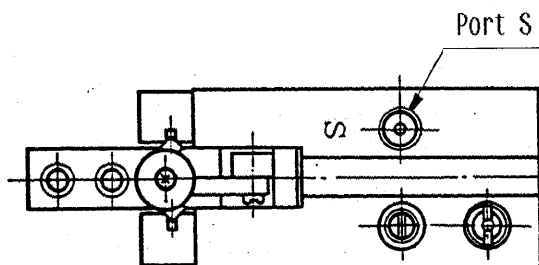

- Piping port

Port S; Port to close finger

Port O; Port to open finger

- Piping port size

Model	Piping port size
MHP10D, MHC10D	M3x0.5
MHP16D, MHC16D	M5x0.8
MHP20D, MHC20D	
MHP25D, MHC25D	

- Piping port

Port S; Port to close finger

- Piping port size

Model	Piping port size
MHP10S, MHC10S	M3x0.5
MHP16S, MHC16S	M5x0.8
MHP20S, MHC20S	
MHP25S, MHC25S	

- Pipe fittings.-use SMC miniature pipe fittings (M3, M5 series) or one-touch fittings (M5 size).
- Pipes to be connected should be air-flushed thoroughly and care should be taken to ensure dirt or cutting-chips do not enter into Air Chuck assembly.

#### 4. Installation adjustment of Air Chuck.

##### 1) Precautions to fit attachment.

When mounting attachment to finger, it should be carried out holding finger by spanner or other means so that the tightening force is not transmitted to the finger guide mechanism. For tightening torque of bolts, refer to the following table.

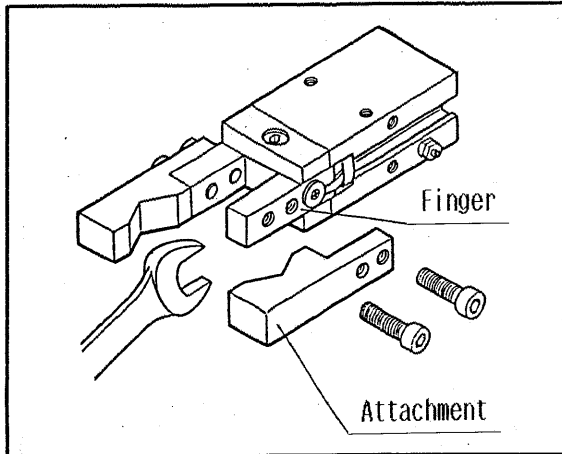

Model	Fixing bolt	Max. tightening torque kgf·cm
MHP10, MHC10	M2.5x0.45	3.2
MHP16, MHC16	M3x0.5	6
MHP20, MHC20	M4x0.7	14
MHP25, MHC25	M5x0.8	29

2) Adjust the device not to receive external force on its finger and some clearance should be kept at stroke end of the finger between finger and the other object.

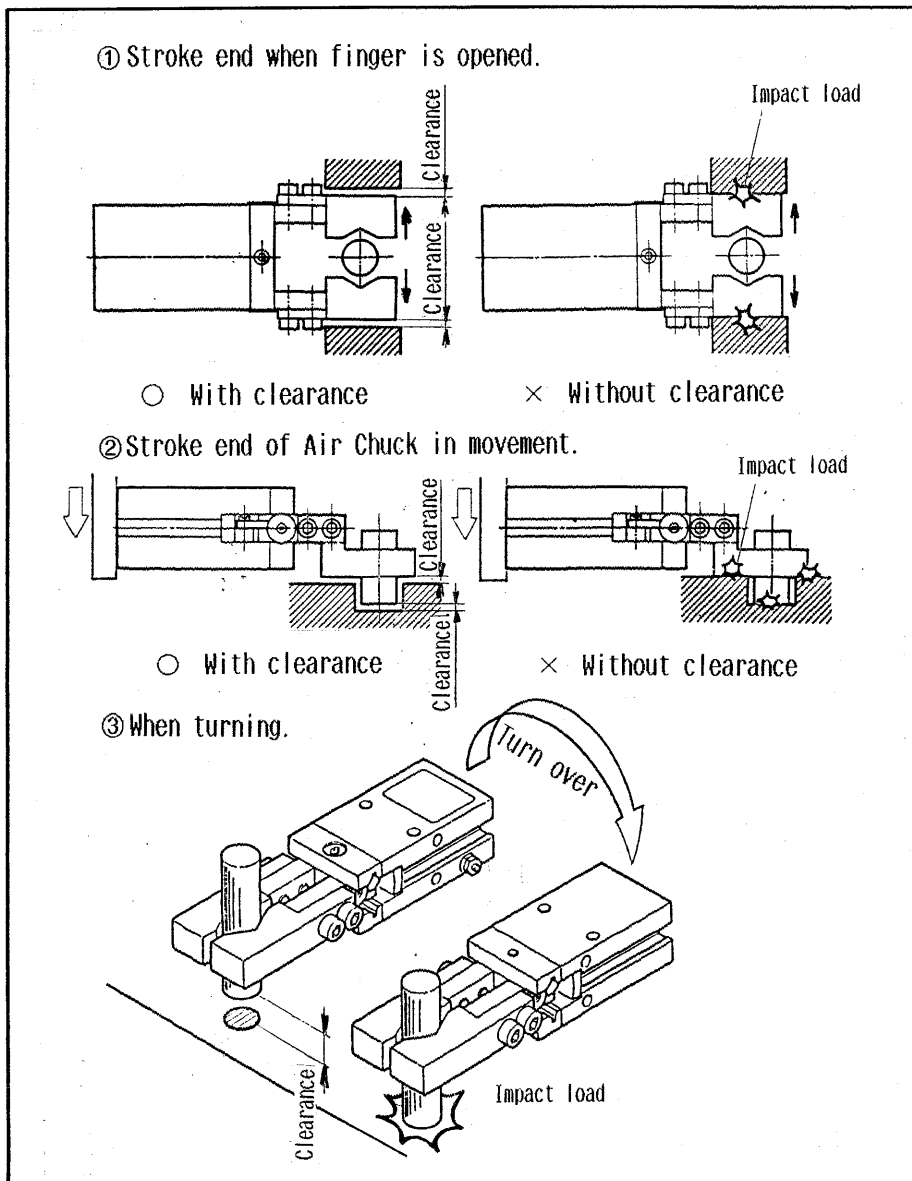

Appropriate clearance should be kept at finger not to receive force except gripping workpiece, particularly when workpiece is gripped, not to crash to other object at stroke end of Air Chuck movement. Lateral load comes on to finger repeatedly or impact load comes on may cause finger to loosening or damage. It is often happens when Air Chuck is turned little variation of length of workpiece may cause to crash at downward stroke end of turning movement. It should be cared.

Before inserting workpiece, centering should be carried out thoroughly not to add unnecessary force to finger. Particularly in test run, keep manual force or air cylinder pressure low to operate and make sure no existence of shock and safety.

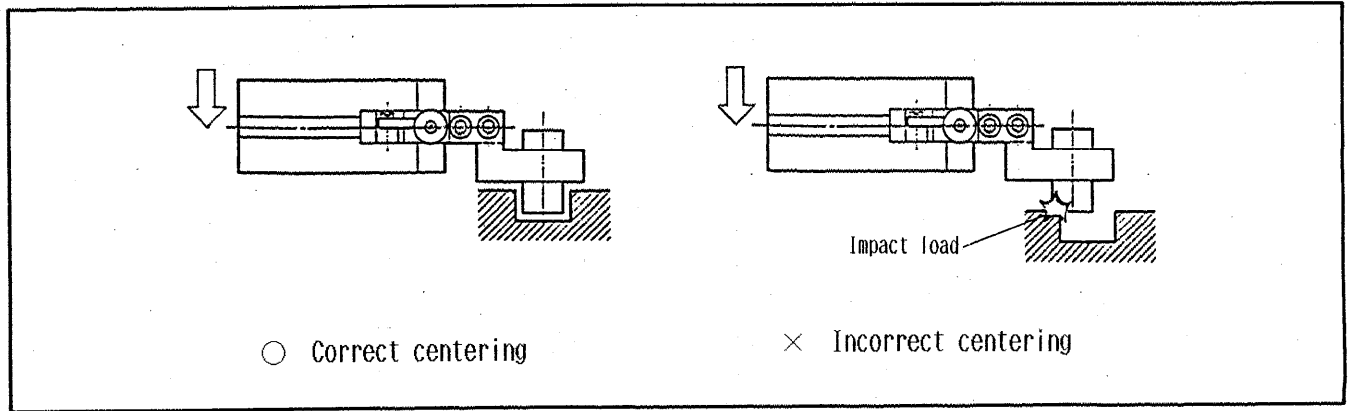

### 3) Adjustment of open-close speed of the finger.

Adjust open-close finger speed not to unnecessarily fast.

- How to adjust open-close finger speed.

Double acting type	Speed can be adjusted by built-in needle. Table below can be referred as a guide.
Single acting type	Connect speed controller * <sub>1</sub> to close side port of the finger and use it as meter-in style.
	* <sub>1</sub> SMC's speed controller AS1000F or equivalent.
	* <sub>2</sub> When needle is tightened to slightly touch bottom
Model	Back turns from the needle fully closed. (* <sub>2</sub> )
MHP10D, MHC10D	1/4 - 1/2
MHP16D, MHC16D	1/2 - 1
MHP20D, MHC20D	1 - 1 1/2
MHP25D, MHC25D	1 1/2 - 2

· In case angular type, in order to avoid impact to the portion of finger base due to inertia moment, adjustment may be needed for making operating speed slower according to the length of attachment.

- If open-close speed is unnecessarily fast, impact force on finger becomes too great and will shorten its life.

#### ◎Adjusting procedure for needle.

- Rotate needle valve clockwise to close and anti-clockwise to open.  
Rotate needle valve clockwise to decrease finger closing speed and anti-clockwise to increase.
- Rotate needle anti-clockwise, drop-preventing function to stop it.  
Do not attempt to rotate further.
- Upon completing adjustment, ensure lock-nut is tightened correctly.

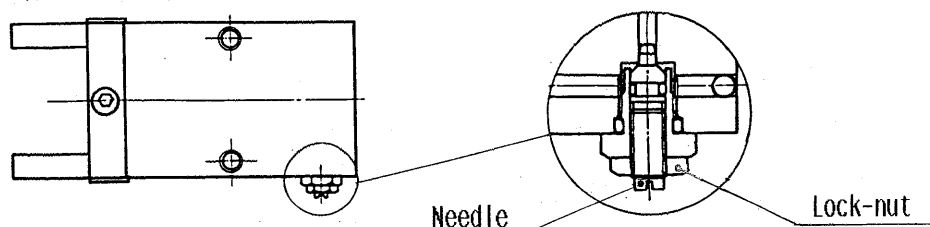

5. Gripping point.

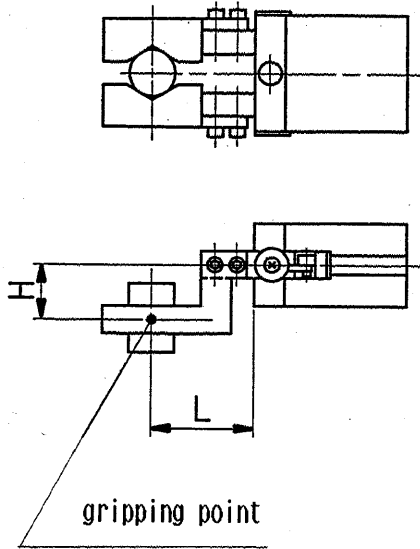

L ; length of gripping point

H ; length of overhang

● Holding point of workpiece is recommended to follow conditions stated in graphs right hand side for L; holding distance subject to working pressure, and H; over-hang quantity.

● Used Chuck outside of recommended area stated in graphs for holding point of workpiece, load coming on finger and guide part becomes excessively great and so may cause to malfunction of the finger or shorten its life.

The products are designed for external work holding. For internal work holding applications please contact us.

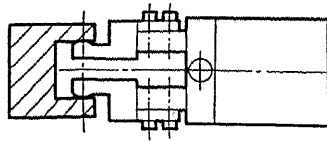
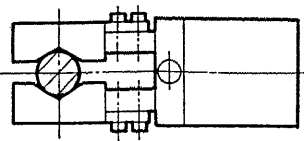

○ external work holding

× internal working holding

Limiting range of gripping point.

MHP10D, MHP10S

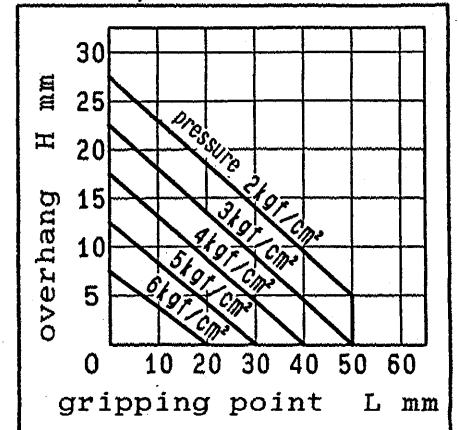

MHP16D, MHP16S

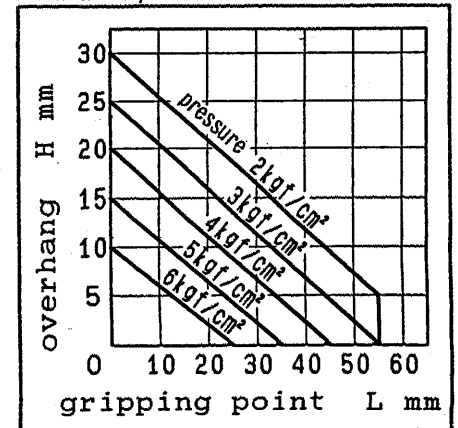

MHP20D, MHP20S

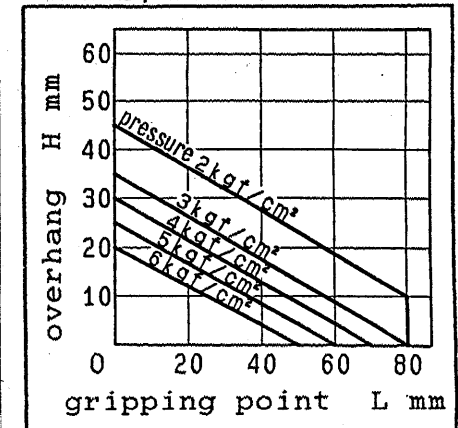

MHP25D, MHP25S

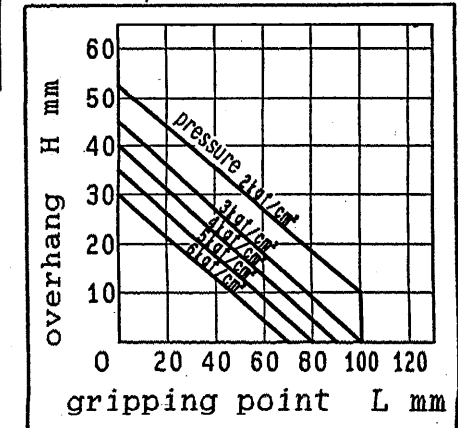

## 7. Effective gripping force for parallel type gripper.

### Gripping Point

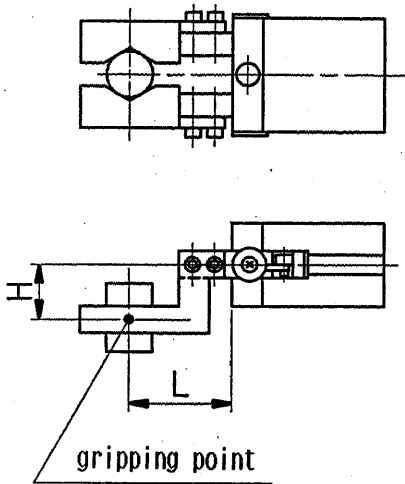

Gripping point ; The length of L and length of H should be used within the limits described on P5.

### Guidelines for The Selection of Air Chuck Model with Respect to Component Weight

- Selection of the correct model depends upon the component weight, the coefficient of friction between the chuck attachment and the component, and their respective configurations. A model should be selected with a gripping force of 10 to 20 times of the component weight.
- If high acceleration, high deceleration or impact are encountered during component transportation then a further margin of safety should be considered.

### Effective Gripping Force

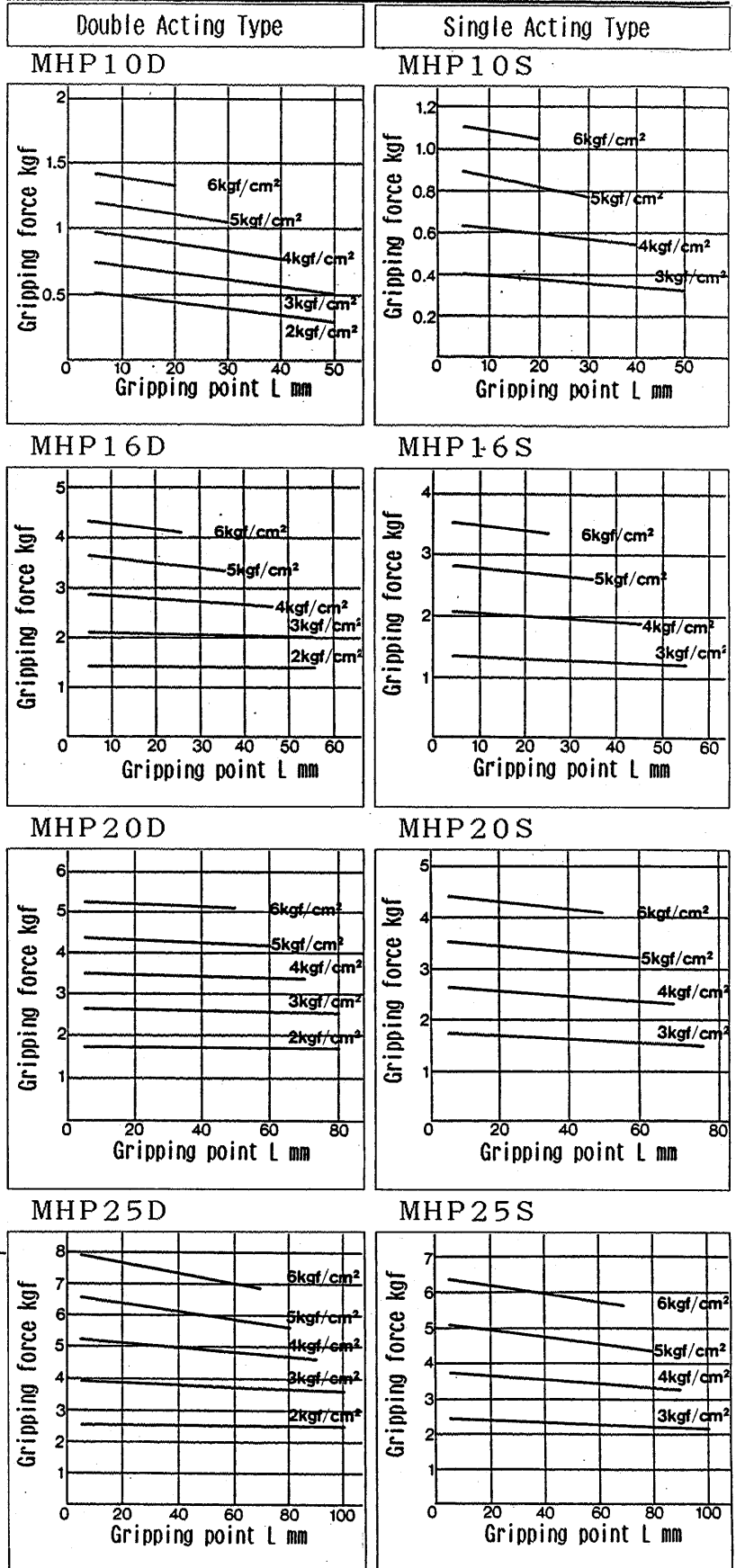

## 8. Effective gripping force for angular type gripper.

Gripping Point

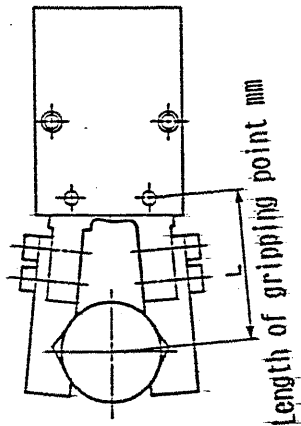

Effective Gripping Force

Double Acting Type

MHC10D

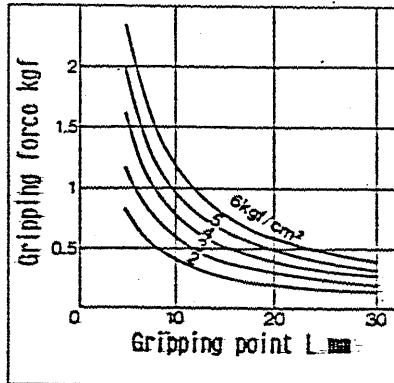

Single Acting Type

MHC10S

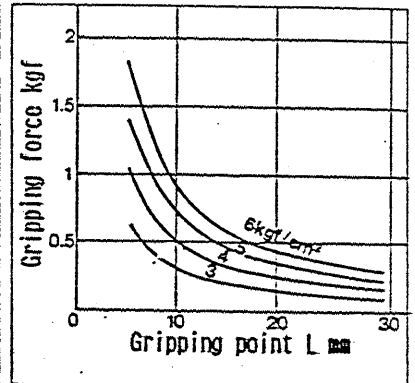

MHC16D

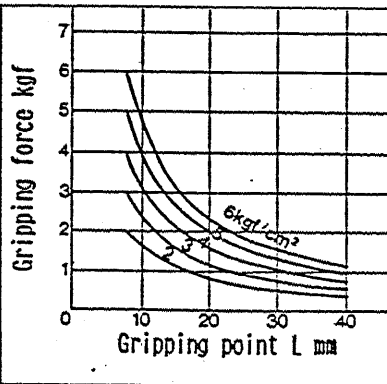

MHC16S

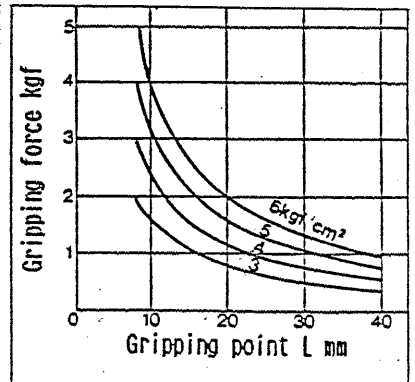

Guidelines for The Selection of Air Chuck Model with Respect to Component Weight

- Selection of the correct model depends upon the component weight, the coefficient of friction between the chuck attachment and the component, and their respective configurations. A model should be selected with a gripping force of 10 to 20 times of the component weight.
- If high acceleration, high deceleration or impact are encountered during component transportation then a further margin of safety should be considered.

MHC20D

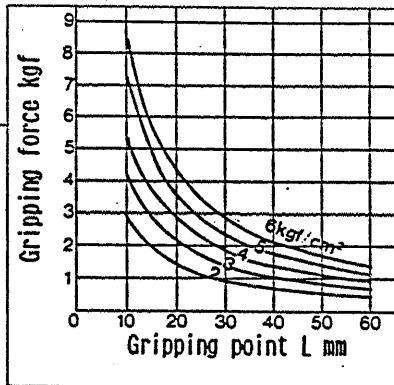

MHC20S

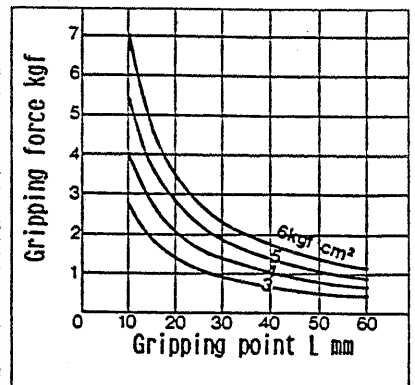

MHC25D

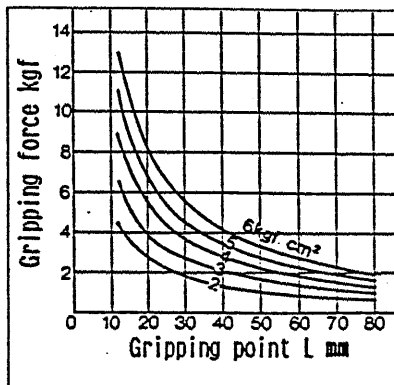

MHC25S

