

Digital Flow Switch Operation Manual



PF2A7□□/PF2W7□□

Thank you for purchasing an SMC PF2A7□□/PF2W7□□ Series Digital Flow Switch. Please read this manual carefully before operating the product and make sure you understand its capabilities and limitations. Please keep this manual handy for future reference.

To obtain more detailed information about operating this product, please refer to the SMC website (URL <http://www.smworld.com>) or contact SMC directly.

Safety Instructions

These safety instructions are intended to prevent hazardous situations and/or equipment damage. These instructions indicate the level of potential hazard with the labels of "Caution", "Warning" or "Danger". They are all important notes for safety and must be followed in addition to International standards (ISO/IEC) and other safety regulations.

- Caution:** CAUTION indicates a hazard with a low level of risk which, if not avoided, could result in minor or moderate injury.
- Warning:** WARNING indicates a hazard with a medium level of risk which, if not avoided, could result in death or serious injury.
- Danger:** DANGER indicates a hazard with a high level of risk which, if not avoided, will result in death or serious injury.

Operator

- This operation manual is intended for those who have knowledge of machinery using pneumatic equipment, and have sufficient knowledge of assembly, operation and maintenance of such equipment. Only those persons are allowed to perform assembly, operation and maintenance.
- Read and understand this operation manual carefully before assembling, operating or providing maintenance to the product.

Safety Instructions

- Warning**
 - Do not disassemble, modify (including changing the printed circuit board) or repair. An injury or failure can result.
 - Do not operate the product outside of the specifications. Do not use for flammable or harmful fluids. Fire, malfunction, or damage to the product can result. Verify the specifications before use.
 - Do not operate in an atmosphere containing flammable, explosive or corrosive gas. Fire or an explosion can result. This product is not designed to be explosion proof.
 - Do not use the product for flammable or highly permeable fluids. A fire or explosion can result.
 - Do not use the product in a place where static electricity is a problem. Otherwise it can cause failure or malfunction of the system.
- Using the product in an interlocking circuit:**
 - Provide a double interlocking system, for example a mechanical system
 - Check the product regularly for proper operation
 - Otherwise malfunction can result, causing an accident.
- The following instructions must be followed during maintenance:**
 - Turn off the power supply
 - Ensure the flow is shut off before performing maintenance
 - Otherwise an injury can result.
- Caution**
 - Do not touch the terminals and connectors while the power is on. Otherwise electric shock, malfunction or damage to the product can result.
 - Do not touch the piping or its connected parts when the fluid is at high temperature. It may lead to burn. Ensure the piping cools sufficiently before touching.
 - After maintenance is complete, perform appropriate functional inspections and leak tests. Stop operation if the equipment does not function properly or there is a leakage of fluid. When leakage occurs from parts other than the piping, the product might be faulty. Disconnect the power supply and stop the fluid supply. Do not apply fluid under leaking conditions. Safety cannot be assured in the case of unexpected malfunction.

Maintenance

How to reset the product after a power cut or forcible de-energizing
The setting of the product will be retained as it was before a power cut or de-energizing. The output condition is also basically recovered to that before a power cut or de-energizing, but may change depending on the operating environment. Therefore, check the safety of the whole installation before operating the product.

Summary of Product parts

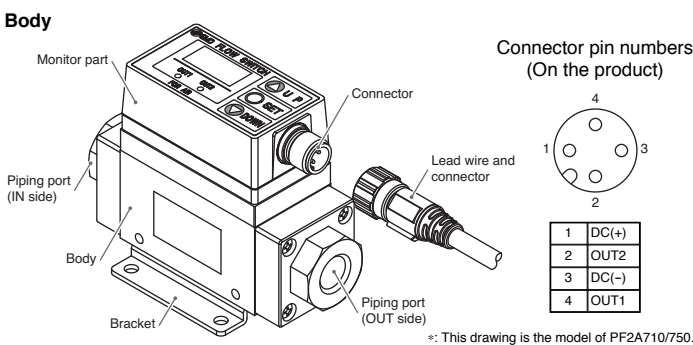

| Item | Description |
|-------------------------|--|
| Monitor part | See below. |
| Piping port | Connected to the fluid inlet at IN side and to the fluid outlet at OUT side. |
| Body | The body of the product. |
| Bracket | Bracket for mounting the product. |
| Connector | Connector for electrical connections. |
| Lead wire and connector | Lead wire to supply power and transmit output signals. |

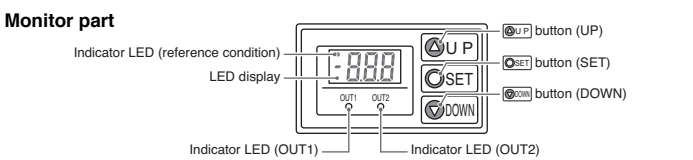

| Item | Description |
|-------------------------------------|---|
| Indicator LED (reference condition) | Indicates the reference condition selected. LED is ON (Red) when normal condition is selected. (Only the PF2A7□□) |
| LED display | Displays the flow value, setting mode, and error indication. |
| Indicator LED (OUT1) | Indicates the output status of OUT1. LED is ON (Green) when OUT1 is ON. The LED flashes when an over current error occurs. When the accumulated pulse output mode is selected, the indicator LED will turn OFF. |
| Indicator LED (OUT2) | Indicates the output status of OUT2. LED is ON (Red) when OUT2 is ON. The LED flashes when an over current error occurs. When the accumulated pulse output mode is selected, the indicator LED will turn OFF. |
| UP button (UP) | Selects the mode or increases the ON/OFF Set value. |
| SET button (SET) | Press this button to change to another mode and to set a value. |
| DOWN button (DOWN) | Selects the mode or decreases the ON/OFF Set value. |

Mounting and Installation

- Never mount the product in a location that will be used as a foothold.
- The rotation angle of the monitor is 270°, in steps of 90°. Rotating the display part with excessive force will damage the end stop.

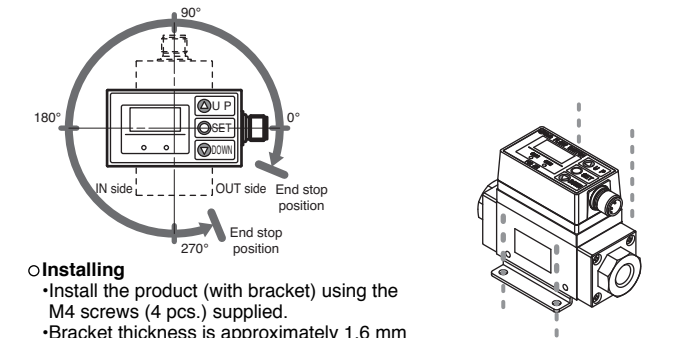

Refer to the product catalogue or SMC website (URL <http://www.smworld.com>) for more information about mounting hole dimensions.

Piping

- Use the product within the specified operating pressure range and temperature range.
- Proof pressure is 1.0 MPa for air and 1.5 MPa for water.
- Connect the piping to the fittings.
- Mount the product so that the fluid direction is the same as the arrow indicated on the product.
- Never mount the product for air upside down.
- The piping on the IN side must have a straight section of piping whose length is 8 times the piping diameter or more.
- Avoid sudden changes in the piping size on the IN side of the product.

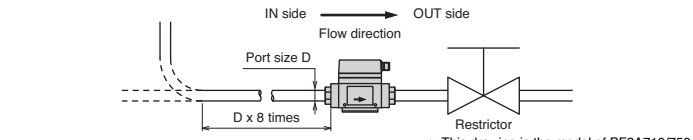

If the product for water is mounted vertically, let the liquid flow from bottom to top. In case of the product for water trapped air bubbles can cause errors in measurement accuracy. (If the fluid detection path is always filled with liquid, there will be no problem.)

Connecting the piping

- Ensure that the metal piping attachments are tightened to the required torque (refer to the table below).
- If the tightening torque is exceeded, the product can be broken. If the tightening torque is insufficient, the fittings may become loose.
- When connecting piping to the product, a spanner should be used on the metal piping attachment only. Using a spanner on other parts may damage the product.
- Avoid any sealing tape from entering inside the piping.
- Ensure that there is no leakage from loose piping.

| Nominal thread size | Required torque | Model | Width across flats of attachment |
|---------------------|-----------------|------------|----------------------------------|
| Rc(NPT)1/8 | 7 to 9 Nm | PF2A710 | 24 mm |
| Rc(NPT)1/4 | 12 to 14 Nm | PF2A751 | 30 mm |
| Rc(NPT)3/8 | 22 to 24 Nm | PF2W704(T) | 34 mm |
| Rc(NPT)1/2 | 28 to 30 Nm | PF2W711 | 30 mm |

Wiring

- Connections should only be made with the power supply turned off.
- Use separate routes for the product wiring and any power or high voltage wiring. Otherwise, malfunction may result due to noise.
- Ensure that the FG terminal is connected to ground when using a commercially available switch-mode power supply. When a switch-mode power supply is connected to the product, switching noise will be superimposed and the product specification can no longer be met. This can be prevented by inserting a noise filter, such as a line noise filter and ferrite core, between the switch-mode power supply and the product, or by using a series power supply instead of a switch-mode power supply.

- Connecting the wiring**
 - Align the lead wire connector with the connector key groove, and insert vertically.
 - Connection is complete when the knurled part is fully tightened. Check that the connection is not loose.

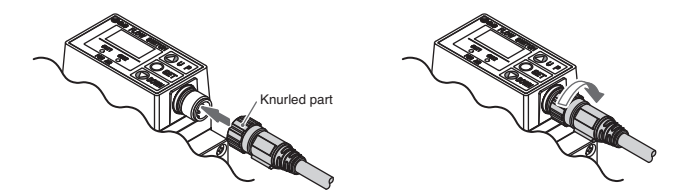

Connector Pin numbers

When the lead wire with connector designated for the PF2A7/PF2W7 is used, the wire colours will apply as shown in the diagram.

| Pin number | Content | Colour |
|------------|---------|--------|
| 1 | DC(+) | Brown |
| 2 | OUT2 | White |
| 3 | DC(-) | Blue |
| 4 | OUT1 | Black |

Outline of setting

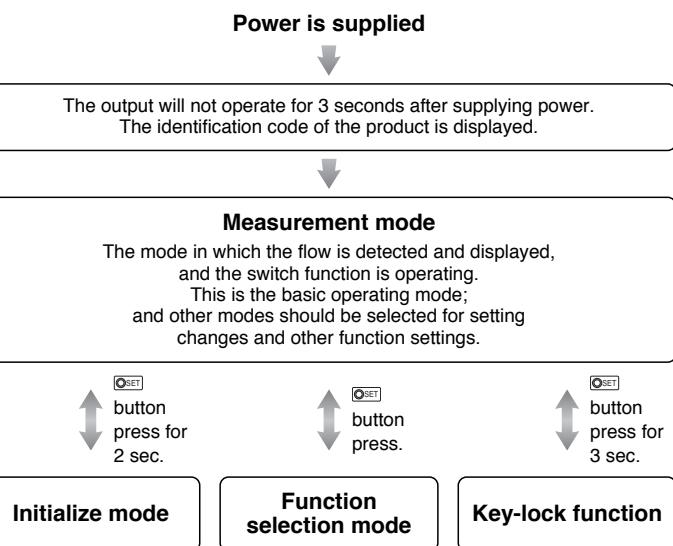

Initialize mode

- Items below can be set.
 - Display mode
 - Output mode (OUT1)
 - Switch operation (OUT1)
 - Reference condition *2
- Unit selection function *1
- Output mode (OUT2)
- Switch operation (OUT2)

Default settings
The default settings are as follows. If this condition is acceptable, then keep these settings.

| Item | Default settings |
|--------------------------------------|----------------------------------|
| Selection of display mode | [d_1] Display instantaneous flow |
| Unit selection function *1 | [U_1] L/min |
| Selection of output mode (OUT1) | [o10] Instantaneous output mode |
| Selection of output mode (OUT2) | [o20] Instantaneous output mode |
| Selection of switch operation (OUT1) | [1_n] Reverse output |
| Selection of switch operation (OUT2) | [2_n] Reverse output |
| Selection of reference condition *2 | [Anr] Standard condition |

- *1: Operate only the product with unit selection function.
- *2: Operate only the PF2A7□□ series.

Key-lock function

This function is used to prevent errors occurring due to unintentional changes of the Set values.

Setting flow chart

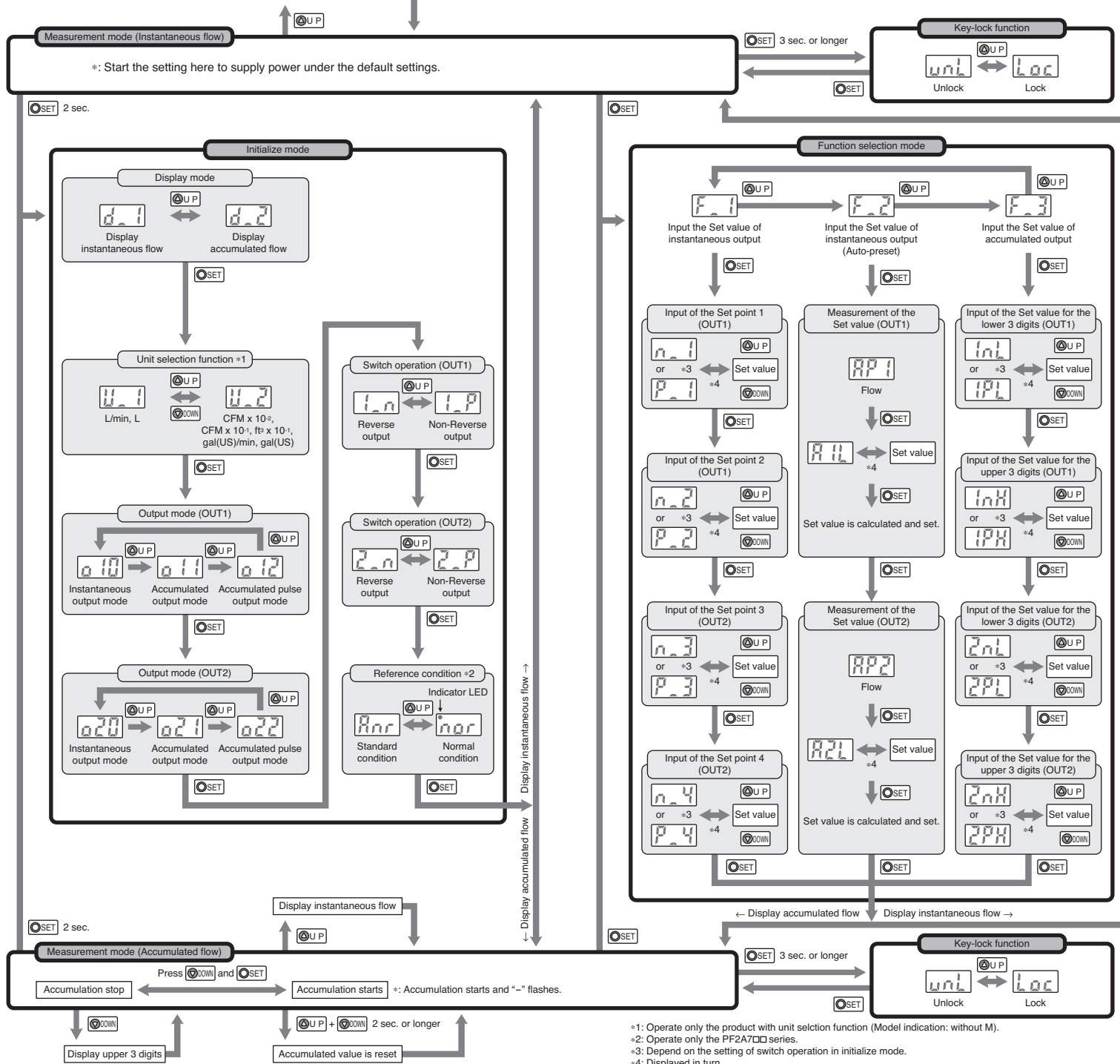

Function selection mode

In measurement mode, press the [F_□] button, to display [F_□]. This [F_□] indicates the mode for changing each functional setting.

- *: When OUT1 or OUT2 is assigned to be instantaneous output mode during initialize mode, [F_1] and [F_2] are displayed.
- When OUT1 or OUT2 is assigned to be accumulated output mode, [F_3] is displayed.

Default settings

The default settings are as follows. If this condition is acceptable, then keep these settings.

| Item | Default setting |
|---|---|
| [F_1] Input the Set value of instantaneous output | [n_1] Input of the Set point 1 (OUT1) 50% of max. rated flow |
| | [n_2] Input of the Set point 2 (OUT1) 50% of max. rated flow |
| | [n_3] Input of the Set point 3 (OUT2) 50% of max. rated flow |
| | [n_4] Input of the Set point 4 (OUT2) 50% of max. rated flow |
| [F_2] Input the Set value of instantaneous output (Auto-preset) | - |
| [F_3] Input the Set value of accumulated output | [1nL] Input of the Set value for the lower 3 digits (OUT1) [0] |
| | [1nH] Input of the Set value for the upper 3 digits (OUT1) [0] |
| | [2nL] Input of the Set value for the lower 3 digits (OUT2) [0] |
| | [2nH] Input of the Set value for the upper 3 digits (OUT2) [0] |

- *: When Non-Reverse output is selected as the switching operation, n becomes P.

List of outputs

Find the diagram of the output you require in the table below. Perform settings following the Set value column on the right. Characters in () are for OUT2.

| Switch output diagram | Output mode | Switch operation | Set value |
|--|---------------------------|---------------------------------|--|
| ON/OFF with hysteresis (P_2, P_1, P_4, P_3) flow | Non-Reverse output | Non-Reverse output | Set point 2 \leq Set point 1 Hysteresis mode *2 |
| ON/OFF with hysteresis (P_1, P_2) flow | Instantaneous output mode | Non-Reverse output | Set point 1 \leq Set point 2 Window comparator mode |
| ON/OFF with hysteresis (n_2, n_1, n_4, n_3) flow | Reverse output | Reverse output | Set point 2 \leq Set point 1 Hysteresis mode *2 |
| ON/OFF with hysteresis (n_1, n_3) flow | Reverse output | Reverse output | Set point 1 $<$ Set point 2 Window comparator mode |
| Accumulated flow (1PH+1PL, 2PH+2PL) flow | Non-Reverse output | Upper 3 digits / Lower 3 digits | Upper 3 digits: $(1PH) + (1PL)$ Lower 3 digits: $(2PH) + (2PL)$ |
| Accumulated flow (1nH+1nL, 2nH+2nL) flow | Reverse output | Upper 3 digits / Lower 3 digits | Upper 3 digits: $(1nH) + (1nL)$ Lower 3 digits: $(2nH) + (2nL)$ |

| Accumulated pulse | Non-Reverse output | Reverse output |
|------------------------|-------------------------------|-------------------------------|
| ON/OFF with 50ms pulse | Accumulated pulse output mode | Accumulated pulse output mode |
| ON/OFF with 50ms pulse | Reverse output | Reverse output |

- *1: In window comparator mode, the hysteresis is fixed at 3 digits. When setting, allow 7 digits or more between Set point 1 and Set point 2 (Set point 3 and Set point 4).
- *2: When Set point 1 = Set point 2 (Set point 3 = Set point 4), chattering may occur.

Troubleshooting

Error indication

| Error name | Error display | Error type | Troubleshooting method |
|------------------------------|---------------|---|--|
| Excessive instantaneous flow | - - - | Flow has exceeded the upper limit of the display flow range. | Reduce the flow. |
| OUT1 over current error | E r 1 | The switch output load current is more than 80 mA (OUT1). | Turn the power off and remove the cause of the over current. Then turn the power on again. |
| OUT2 over current error | E r 2 | The switch output load current is more than 80 mA (OUT2). | Turn the power off and remove the cause of the over current. Then turn the power on again. |
| System error | E r 4 | The set data has been changed unexpectedly. | To reset, press [UP] and [DOWN] buttons simultaneously for 2 seconds or longer. Then set all data again. |
| Excessive accumulated flow | 99.9 | The display flow range of accumulated flow has been exceeded. | To reset the accumulated flow value, press [UP] and [DOWN] buttons simultaneously for 2 seconds or longer. |

*: If the error cannot be reset after the above measures are taken, then please contact SMC.

Refer to the SMC website (URL <http://www.smworld.com>) for more information about troubleshooting.

Specifications / Outline with Dimensions

Refer to the product catalogue or SMC website (URL <http://www.smworld.com>) for more information about the product specifications and outline dimensions.