



Operation Manual

PRODUCT NAME

Digital Gap Checker

MODEL / Series / Product Number

ISA3-##A/B-#

- 2 switch outputs (NPN or PNP)
OUT1: Distance detection
OUT2: Pressure or distance detection

SMC Corporation

Table of Contents

1 Before Use	Safety Instructions 2
2 About this product	Features 7 Model Indication and How to Order 8 Summary of Product parts 14 Specification 15 Specifications (ISA3) 15 Specifications (Regulator) 17 Specifications (2 port solenoid valve) 17 Characteristics graph 18 Dimensions 21
3 Installation	Mounting and Installation 27 Piping 27 Installation 30 Wiring 35 Part structure 39
4 How to use	Outline of setting 42 Measurement mode 43 Switch Point Setting 45 OUT1: Switch point OUT2: Pressure setting 45 Default settings of OUT1 45 Default settings of OUT2 46 Preparation before setting 47 Setting 47 Function Setting 48 Function selection mode 48 Table of default settings 48 Key lock (Security code setting) 62
5 Troubleshooting	Maintenance 63 Forgotten the security code 64 Troubleshooting 65 Error indication 66 Relationship between Supply Pressure and Display 67



Safety Instructions

These safety instructions are intended to prevent hazardous situations and/or equipment damage. These instructions indicate the level of potential hazard with the labels of "Caution", "Warning" or "Danger". They are all important notes for safety and must be followed in addition to International Standards (ISO/IEC)*1), and other safety regulations.

*1) ISO 4414: Pneumatic fluid power -- General rules relating to systems.

ISO 4413: Hydraulic fluid power -- General rules relating to systems.

IEC 60204-1: Safety of machinery -- Electrical equipment of machines .(Part 1: General requirements)

ISO 10218: Manipulating industrial robots -Safety.

etc.



Caution

Caution indicates a hazard with a low level of risk which, if not avoided, could result in minor or moderate injury.



Warning

Warning indicates a hazard with a medium level of risk which, if not avoided, could result in death or serious injury.



Danger

Danger indicates a hazard with a high level of risk which, if not avoided, will result in death or serious injury.

Warning

1. The compatibility of the product is the responsibility of the person who designs the equipment or decides its specifications.

Since the product specified here is used under various operating conditions, its compatibility with specific equipment must be decided by the person who designs the equipment or decides its specifications based on necessary analysis and test results.

The expected performance and safety assurance of the equipment will be the responsibility of the person who has determined its compatibility with the product.

This person should also continuously review all specifications of the product referring to its latest catalog information, with a view to giving due consideration to any possibility of equipment failure when configuring the equipment.

2. Only personnel with appropriate training should operate machinery and equipment.

The product specified here may become unsafe if handled incorrectly.

The assembly, operation and maintenance of machines or equipment including our products must be performed by an operator who is appropriately trained and experienced.

3. Do not service or attempt to remove product and machinery/equipment until safety is confirmed.

1. The inspection and maintenance of machinery/equipment should only be performed after measures to prevent falling or runaway of the driven objects have been confirmed.

2. When the product is to be removed, confirm that the safety measures as mentioned above are implemented and the power from any appropriate source is cut, and read and understand the specific product precautions of all relevant products carefully.

3. Before machinery/equipment is restarted, take measures to prevent unexpected operation and malfunction.

4. Contact SMC beforehand and take special consideration of safety measures if the product is to be used in any of the following conditions.

1. Conditions and environments outside of the given specifications, or use outdoors or in a place exposed to direct sunlight.

2. Installation on equipment in conjunction with atomic energy, railways, air navigation, space, shipping, vehicles, military, medical treatment, combustion and recreation, or equipment in contact with food and beverages, emergency stop circuits, clutch and brake circuits in press applications, safety equipment or other applications unsuitable for the standard specifications described in the product catalog.

3. An application which could have negative effects on people, property, or animals requiring special safety analysis.

4. Use in an interlock circuit, which requires the provision of double interlock for possible failure by using a mechanical protective function, and periodical checks to confirm proper operation.



Safety Instructions

! Caution

1. The product is provided for use in manufacturing industries.

The product herein described is basically provided for peaceful use in manufacturing industries. If considering using the product in other industries, consult SMC beforehand and exchange specifications or a contract if necessary. If anything is unclear, contact your nearest sales branch.

Limited warranty and Disclaimer/Compliance Requirements

The product used is subject to the following "Limited warranty and Disclaimer" and "Compliance Requirements".

Read and accept them before using the product.

Limited warranty and Disclaimer

1. The warranty period of the product is 1 year in service or 1.5 years after the product is delivered, whichever is first.*2)

Also, the product may have specified durability, running distance or replacement parts. Please consult your nearest sales branch.

2. For any failure or damage reported within the warranty period which is clearly our responsibility, a replacement product or necessary parts will be provided.

This limited warranty applies only to our product independently, and not to any other damage incurred due to the failure of the product.

3. Prior to using SMC products, please read and understand the warranty terms and disclaimers noted in the specified catalog for the particular products.

*2) Vacuum pads are excluded from this 1 year warranty.

A vacuum pad is a consumable part, so it is warranted for a year after it is delivered.

Also, even within the warranty period, the wear of a product due to the use of the vacuum pad or failure due to the deterioration of rubber material are not covered by the limited warranty.

Compliance Requirements

1. The use of SMC products with production equipment for the manufacture of weapons of mass destruction (WMD) or any other weapon is strictly prohibited.

2. The exports of SMC products or technology from one country to another are governed by the relevant security laws and regulation of the countries involved in the transaction. Prior to the shipment of a SMC product to another country, assure that all local rules governing that export are known and followed.

! Caution

SMC products are not intended for use as instruments for legal metrology.

Products that SMC manufactures or sells are not measurement instruments that are qualified by pattern approval tests relating to the measurement laws of each country.

Therefore, SMC products cannot be used for business or certification ordained by the measurement laws of each country.

■ Important

In order to use this product safely, be sure to read and follow the instructions given in "Pressure switches/Flow switches common precautions" which can be found under "Handling Precautions for SMC Products" on the SMC website, before use.

■ Operator

- ◆ This operation manual is intended for those who have knowledge of machinery using pneumatic equipment, and have sufficient knowledge of assembly, operation and maintenance of such equipment. Only those persons are allowed to perform assembly, operation and maintenance.
- ◆ Read and understand this operation manual carefully before assembling, operating or providing maintenance to the product.

■ Specific product precautions

⚠ Warning

About this product

- **This product is not designed to be explosion proof.**
- **Do not use a fluid containing chemicals, synthetic oils including organic solvent, salt and corrosive gases.**
Otherwise damage to the product, malfunction and failure can result.
- **Writing time of input data to product is 1000000 times.**

Design

- **The product should be positioned higher than the detection nozzle.**
If the product is positioned lower than the detection nozzle, water or oil may enter the detection port, causing a malfunction or operational failure.

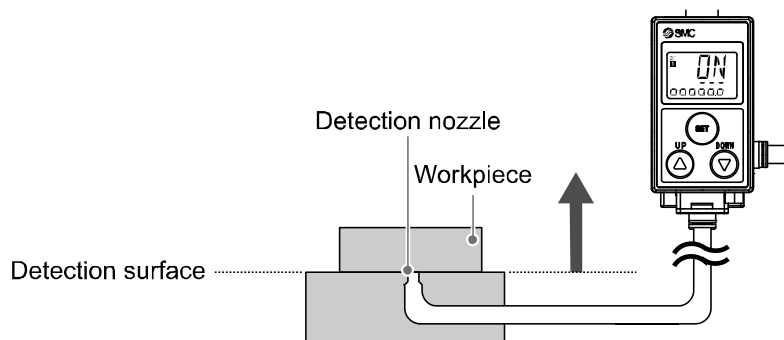

- **Do not use multiple detection nozzles with one product.**
Correct measurement may not be possible. If multiple nozzles are to be used, please test them on the actual equipment. It is necessary for the user to verify correct operation.

Warning

Mounting/Installation

- **If the entering of foreign material to the fluid is possible, install the filter (5 μm or less) or the mist separator to the upstream side.**
- **If compressed air containing condensate is used, install the air dryer or the drain catch before the filter, and perform drainage regularly.**

If regular drainage is difficult, the use of a filter with an auto drain is recommended.

Piping

- **Eliminate any dust left in the piping by air blow before connecting the piping to the product.**

Otherwise it can cause damage to the product, malfunction or failure.

- **Perform function and leakage inspection after piping.**

Safety cannot be assured in the case of unexpected malfunction. Disconnect the power supply and stop the fluid supply if the equipment does not function properly or if there is leakage of fluid.

- **Do not use equipment or fittings that may leak or obstruct the air flow between the product and the detection nozzle.**

Wiring

- **The product is CE marked, but not immune to lightning strikes. Take measures against lightning strikes in the system.**

- **Limit of the lead wire tensile force is 50 N.**

Do not lift or carry the product by holding the lead wire.

- **If the lead wire can move, fix it near the body of the product.**

- **Keep wiring as short as possible to prevent interference from electromagnetic noise and surge voltage.**

Do not use a lead wire longer than 30 m.

Wire the DC (-) line (blue) as close as possible to the power supply.

Operating environment

- **Do not use the product in an environment where the product is constantly exposed to water or oil splashes.**

Otherwise it can cause failure or malfunction. Take measures such as using a cover.

- **Do not use in an atmosphere containing oil, corrosive gases, chemicals, sea water, or where there is direct contact with any of these.**

Even exposure for a short period of time, will have adverse effects including damage, failure, malfunction and hardening of the lead wire.

- **Do not use the product in the presence of a magnetic field.**

Otherwise malfunction can result.

- **Do not operate close to a heat source, or in a location exposed to radiant heat.**

Otherwise malfunction can result.

- **When the product is contained in a box for use, provide an exhaust port for constant release of pressure to atmosphere.**

If the pressure in the box is not atmospheric pressure, correct inspection will not be available and malfunction may result.

- **The enclosure of the switch conforms to IP67 and that for the solenoid valve to IP65. The pressure gauge and the regulator have open constructions. Take proper protection measures in an environment where water splashes, oil or spatters from welding may adhere to the product.**

 **Warning**Usage**•Do not short-circuit the load.**

When the load is short circuit, generated excess current lead to cause the damage of the product.

•Do not press the setting buttons with a sharp pointed object.

It may damage the setting buttons.

•During the any setting, the product will switch the output according to the existing settings until the changes are complete.

Confirm the output has no adverse effect on machinery and equipment before setting.

Stop the control system before setting if necessary.

•Perform settings suitable for the operating conditions.

Incorrect setting can cause operation failure.

For details of each setting, refer to each "Setting" 42 page of this manual.

•Do not touch the LCD during operation.

The display can vary due to static electricity.

Maintenance Service**•Drain system regularly.**

If condensate enters the secondary side, it may cause malfunction of pneumatic equipment.

◆Please read and understand the cautions in the Operation Manuals for VX2 series (2 port solenoid valve) and AR20 series (Regulator) before use.

Features

The Gap between the detection surface and the workpiece (0.01 mm to 0.03 mm, 0.02 mm to 0.15 mm, 0.05 mm to 0.30 mm) can be detected.

The Gap condition is indicated on the main screen in Green (ON) or Orange (OFF). *: Default setting.

The sub screen indicates the distance between the detection surface and the workpiece using a level meter.

This product is a non-contact switch which will not scratch the workpiece.

(A) The Workpiece is not seated in the correct position due to a foreign object.

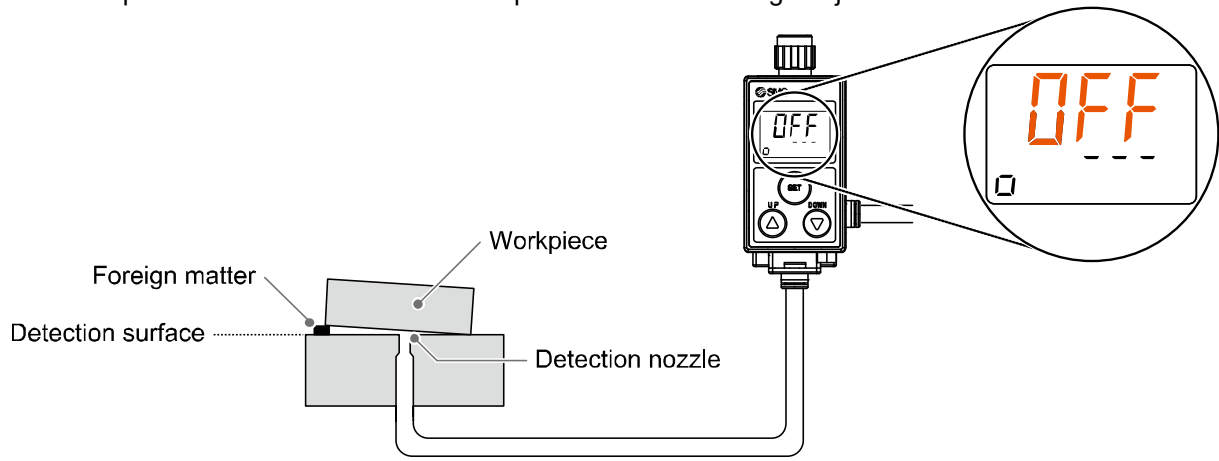

(B) Within the acceptable range (Seats correctly).

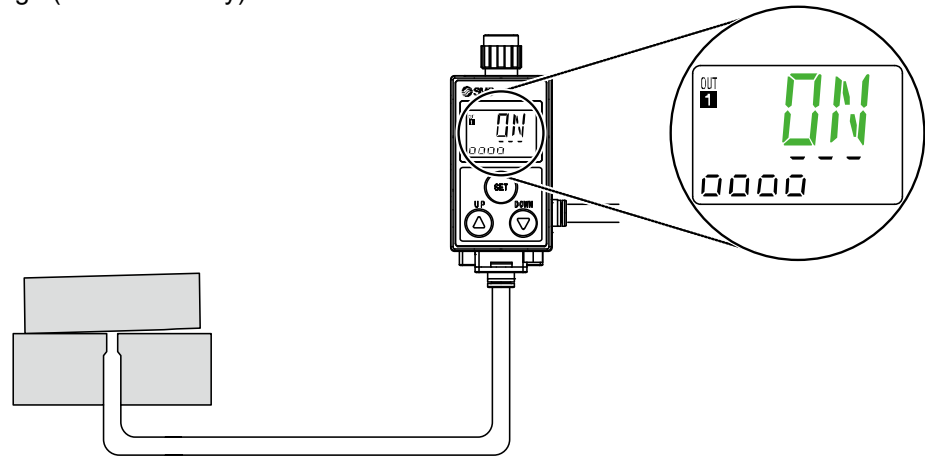

(C) The Workpiece is more closely in contact than in (B).

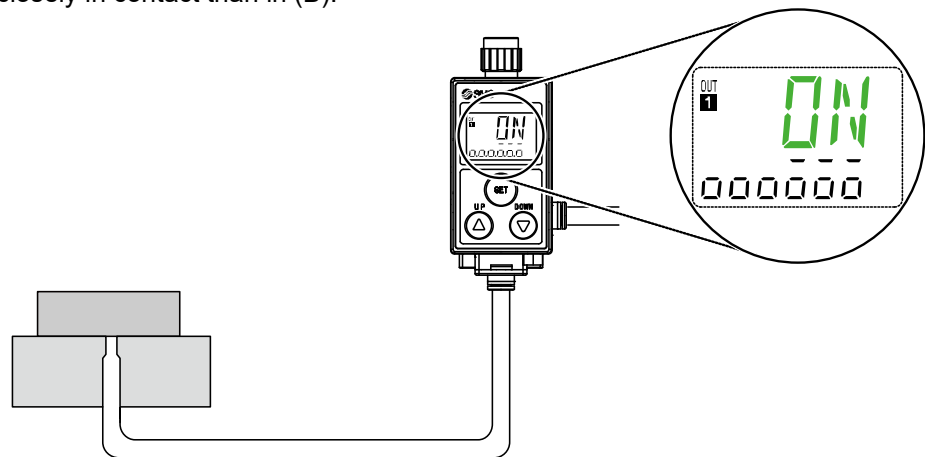

Model Indication and How to Order

○Without control unit

ISA3 - **G** **C** **A** - **M** **1** **□** **□**

Rated distance range

F	0.01 to 0.03 mm
G	0.02 to 0.15 mm
H	0.05 to 0.30 mm

Piping specifications

C	Supply side: Rc1/8 Detection side: φ 4 One-touch fitting *1 φ 6 One-touch fitting *2
	F
F	Supply side: G1/8 *3 Detection side: G1/8 *3

Output specifications

A	NPN 2 output
B	PNP 2 output

Unit specifications

Nil	With units selection function *4
M	Fixed SI unit *5

Number of stations

1	1 Station
2	2 Stations
3	3 Stations
4	4 Stations
5	5 Stations
6	6 Stations

Option 2 (Bracket)

Nil	None (DIN rail mounting) *9
B	With bracket *7 *10

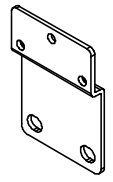

Option 1 (Lead wire)

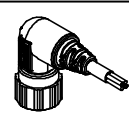
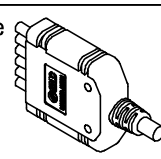
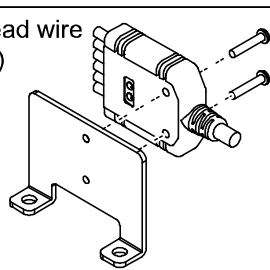
Nil	Straight *7	
L	Right angle *7	
N	None	
S	Centralized lead wire (Lead wire only) *6 *7 *8	
T	Centralized lead wire (With bracket) *6 *7 *8	

*1: To be used for the rated distance range of "F".

*2: To be used for the rated distance range of "G" or "H".

*3: ISO1179-1

*4: The new Measurement Law prohibits the use of pressure switch with the units selection function in Japan.

*5: Fixed unit: kPa

*6: Cannot be selected for 1 station.

*7: At the factory, the options are not attached to the product, but packed together with it for shipment.

*8: Refer to *8 (page 10).

*9: DIN rail must be ordered separately.

*10: About the number of brackets.

1 station: 1 piece is packed

More than 2 stations: 2 pieces is packed

○With control unit

ISA3 - **G** **C** **A** - **M** **2** **□** **B** - **L** **1** **□**

Rated distance range

F	0.01 to 0.03 mm
G	0.02 to 0.15 mm
H	0.05 to 0.30 mm

Piping specifications

C	Supply side: Rc1/8 Detection side: φ 4 One-touch fitting *1 φ 6 One-touch fitting *2
	F
F	Supply side: G1/8 *3 Detection side: G1/8 *3

Control unit piping *11

Gap checker piping	Supply port piping
C	Rc1/4
F	G1/4 *12

Output specifications

A	NPN 2 output
B	PNP 2 output



Unit specifications

Nil	With units selection function *4
M	Fixed SI unit *5

Number of stations

1	1 Station
2	2 Stations
3	3 Stations
4	4 Stations
5	5 Stations
6	6 Stations

Option 1 (Lead wire)

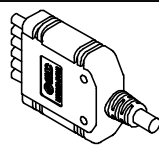
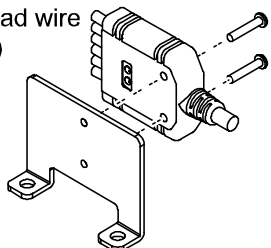
Nil	Straight *7	
L	Right angle *7	
N	None	
S	Centralized lead wire (Lead wire only) *6 *7 *8	
T	Centralized lead wire (With bracket) *6 *7 *8	

Rated voltage
2 port solenoid valve

Nil	24 VDC
1 *10	100 VAC
2 *10	110 VAC

Regulator

N *10	Without regulator
0 *10	Without pressure gauge
1	Round pressure gauge MPa only, 0.4 MPa max.
2	Square pressure gauge MPa only, 0.4 MPa max.
3	Round pressure gauge MPa only, 0.2 MPa max.
4	Square pressure gauge MPa only, 0.2 MPa max.
5 *10	With regulator Round pressure gauge MPa/psi, 0.4 MPa max.
6 *10	Square pressure gauge MPa/psi, 0.4 MPa max.
7 *10	Round pressure gauge MPa/psi, 0.2 MPa max.
8 *10	Square pressure gauge MPa/psi, 0.2 MPa max.

Control unit

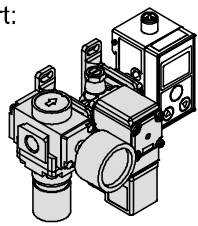
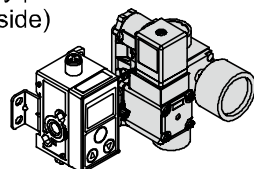
L	With control unit (Supply port: Left side)	
R	With control unit (Supply port: Right side)	

Option 2 (Bracket)

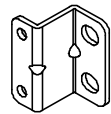
B	With bracket *9	
---	-----------------	---

- *1: To be used for the rated distance range of "F".
- *2: To be used for the rated distance range of "G" or "H".
- *3: ISO1179-1
- *4: The new Measurement Law prohibits the use of pressure switch with the units selection function in Japan.
- *5: Fixed unit: kPa
- *6: Cannot be selected for 1 station.
- *7: At the factory, the options are not attached to the product, but packed together with it for shipment.
- *8: The electrical entry of centralized lead wire for M12 connector is on the right side.

If the supply port on the right side is used, arrange the centralized lead wire so that it does not interfere with the control unit.

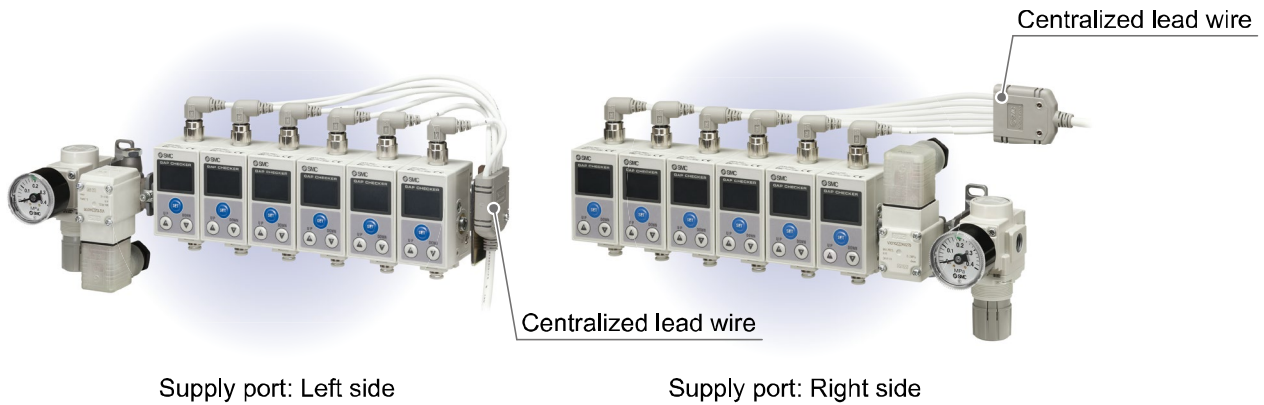

- *9: The bracket for control unit will be assembled before shipment.
- *10: Made to order
- *11: When the control unit is mounted, the piping specifications of the supply port will be changed due to piping specification of the gap checker.
- *12: ISO16030

○ Option/Part number

Joint screws
(2 screws, 2 spacers *, 2 nuts)

ISA-16-□

Number of stations	Part number
2	ISA-16-2
3	ISA-16-3
4 *	ISA-16-4
5	ISA-16-5
6 *	ISA-16-6

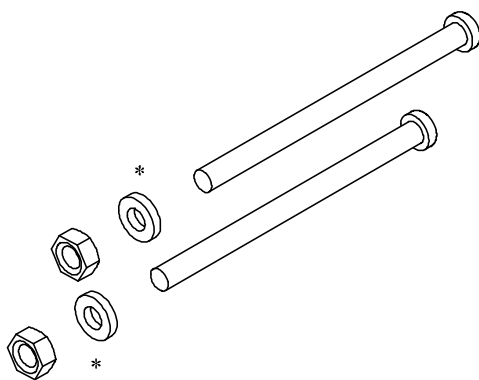

*: Spacers are included for 4 and 6 stations.

Bracket (when control unit not fitted)
(Nominal size: 3 x 8, 3 screws)

ISA-14

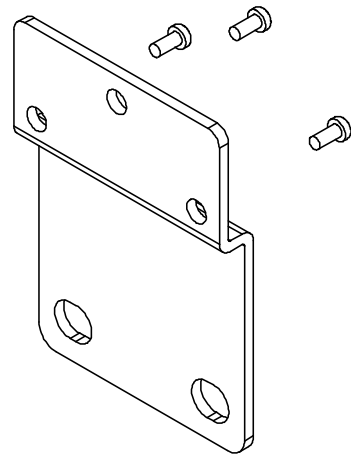

With connector lead wire
ZS-31-B

With connector lead wire
ZS-31-C

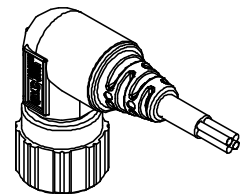

DIN rail

ISA-5-□

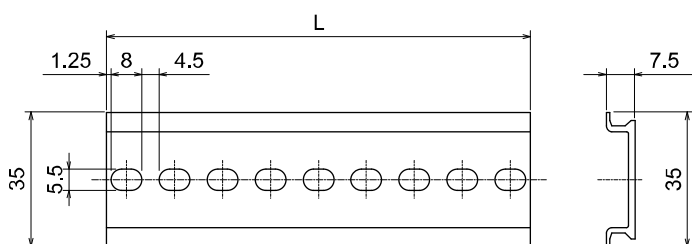

Part number	L	Number of stations
ISA-5-1	73.0	1
ISA-5-2	135.5	2
ISA-5-3	173.0	3
ISA-5-4	210.5	4
ISA-5-5	248.0	5
ISA-5-6	285.5	6

Threaded plug with seal

ISA-12-□

Piping type	Part number
Rc1/8	ISA-12-A
G1/8	ISA-12-C



Seal for extra station *

ISA-15



*: This is applicable in both piping specification C and F.

Centralized lead wire

ISA-21-□

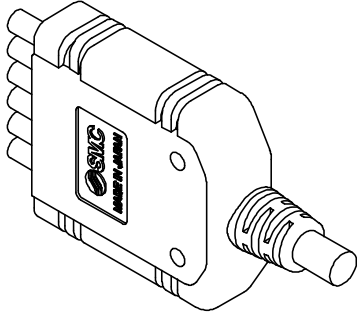

Stations	Model
2	ISA-21-2
3	ISA-21-3
4	ISA-21-4
5	ISA-21-5
6	ISA-21-6

Bracket for centralized lead wire

ISA-20

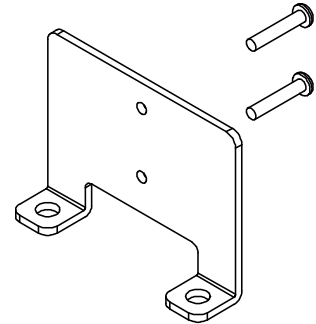

Regulator

AR20-□02□-1□-B□

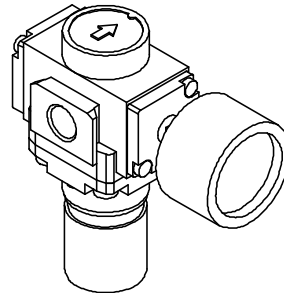
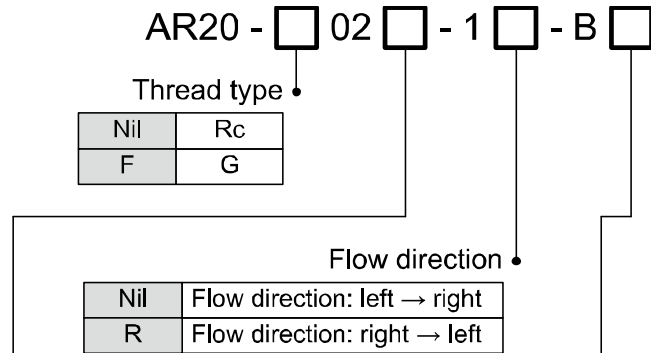

• Option (Pressure gauge type)

• Maximum pressure display of the pressure gauge

Nil	Without pressure gauge	Nil	-
E	With square embedded gauge (with limit indicator)	Nil	Max. pressure display: 0.4 MPa
		-X2105	Max. pressure display: 0.2 MPa
		-X2176	Max. pressure display: 60 PSI (0.4 MPa) ^{*2}
G ^{*1}	With round pressure gauge (with limit indicator, display in MPa only)	Nil	Max. pressure display: 0.4 MPa
		-X2105	Max. pressure display: 0.2 MPa
		-X2175	Max. pressure display: 30 PSI (0.2 MPa) ^{*2}
P ^{*1}	With round pressure gauge (with limit indicator, display in MPa/psi) ^{*2}	Nil	Max. pressure display: 0.4 MPa
		-X2105	Max. pressure display: 0.2 MPa

*1: The mounting thread of the pressure gauge is Rc1/8. The pressure gauge is shipped together with the product, but not assembled.

*2: This product will not be sold for use in Japan.

2 port solenoid valve

VX210□□X276

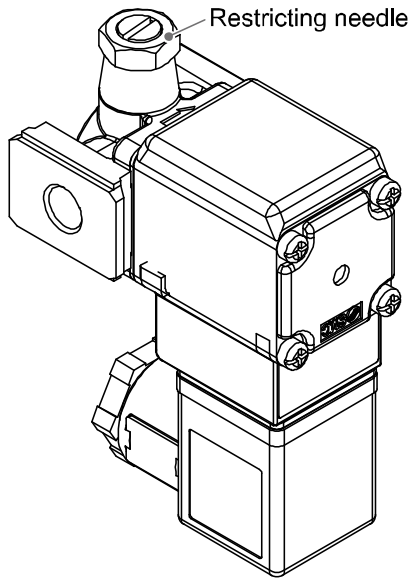

VX210□□X276

Specifications

Symbol	Specification
X276	With restrictor

Voltage and Electrical entry

Symbol	Voltage	Electrical entry
Z2A	24 VDC	With DIN terminal and light (with surge voltage suppressor)
Z2B *2	100 VAC	
Z2C *2	110 VAC	

*2: Made to order. When AC100 V and AC110 V are selected, the product without thread machining (symbol: Z) cannot be selected.

Body material, Port size, Orifice size

Symbol	Body material	Port size	Orifice size
Z	Al	Without thread machining (1/8)	φ 4
B *1		Rc1/4	
D *1		G1/4	

*1: Made to order

Bracket (when control unit fitted)
(Nominal size:3 x 8, 2 screws)

ISA-17

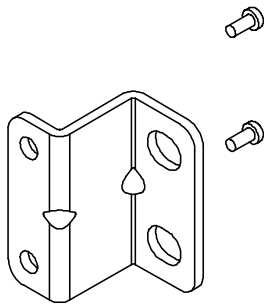

Spacer with bracket

Y200T-A

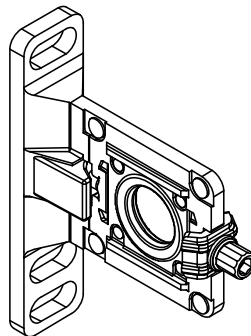

Modular adapter

E210-U01

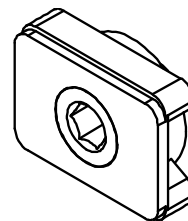

Spacer

ISA-18



With O-ring

*: When a 2 port solenoid valve is connected to the right.

Summary of Product parts

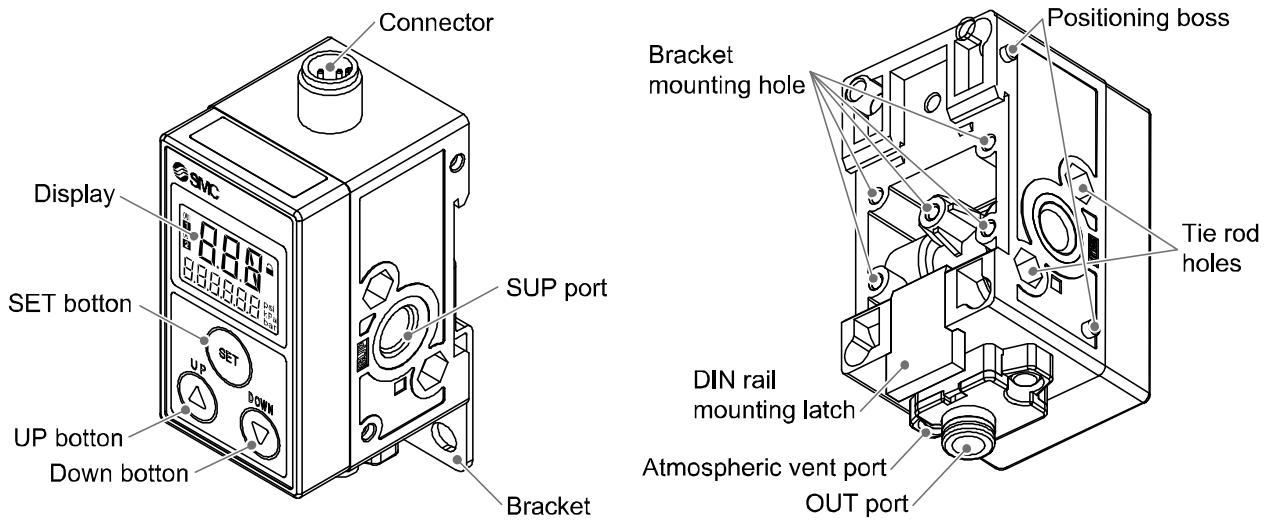

Element	Description
Display	See below
UP button (▲ button)	Selects the mode and the display shown on the sub screen, or increases the switch point.
SET button (SET button)	Press this button to change the mode and to fix the settings.
DOWN button (▼ button)	Selects the mode and the display shown on the sub screen, or decreases the switch point.
Connector	Electrical connection.
SUP port (Supply port)	Port to supply pressure.
Bracket mounting hole	Used to attach the bracket to the product.
Tie rod holes	Used to connect additional products.
OUT port (Detection port)	Port to be connected to the detection nozzle.
Atmospheric vent port	Port to vent exhaust air to the atmosphere.
DIN rail mounting latch	Used to mount the product on a DIN rail.

Display

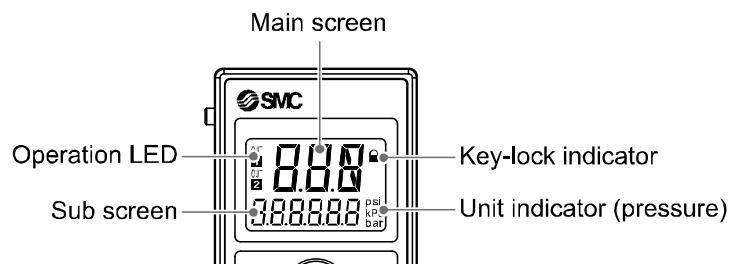

Element	Description
Main screen	ON/OFF, display value, error code and pressure are displayed. (2 colour display)
Operation LED	Indicates the switch output status. Turns ON (orange) when the switch output is ON.
Sub screen	Level meter, display value, switch point, pressure etc. are displayed.
Key-lock indicator	Turns ON when keys are locked.
Unit indicator (pressure)	When pressure is displayed on the sub screen, indicates the pressure unit currently selected.

Specification

■ Specifications (ISA3)

Model		ISA3-F	ISA3-G	ISA3-H
Applicable fluid		Dry air (Filtered through a 5 µm filter)		
OUT1 OUT2*5	Rated distance range	0.01 to 0.03 mm	0.02 to 0.15 mm	0.05 to 0.30 mm
	Displayable/Settable range (Distance reference)*1	0 to 60*2	10 to 300*2	30 to 500*2
	Minimum display resolution (Distance reference)*1	1		
	Rated pressure range	100 to 200 kPa		
	Displayable range (Pressure value)*3	-20 to 220 kPa		
	Repeatability	0.005 mm or less	0.010 mm or less	0.020 mm or less
	Temperature characteristics (Reference: 25 °C)	0.010 mm or less	0.015 mm or less	0.030 mm or less
	Hysteresis	0 to variable (Default: 3)	0 to variable (Default: 20)	
OUT2*6	Rated pressure range	0 to 200 kPa		
	Setting pressure range	-20 to 220 kPa		
	Minimum display/setting resolution	1 kPa		
	Repeatability	±0.5%F.S. ±1 digit		
	Temperature characteristics (Reference: 25 °C)	±2%F.S.		
	Hysteresis	0 to variable*7		
Withstand pressure		600 kPa		
Detection nozzle		φ1.5*4		
Current flow		5 L/min or less	12 L/min or less	22 L/min or less
Power supply voltage		24 VDC ±10%, Ripple(p-p) 10% or less (with power supply polarity protection)		
Current consumption		25 mA or less		
Switch output		2 output (NPN or PNP)		
	Max. load current	10 mA		
	Max. applied voltage	26.4 V		
	Residual voltage	1 V or less (at 10 mA)		
	Short circuit protection	Provided		
Display		2-screen display LCD Main screen: 3-digit, 7-segment 2-colour (Orange/Green) Sub screen: 6-digit, 7-segment 1-colour (White)		
Environment	Enclosure	IP67 equivalent*8		
	Operating temp. range	Operation: 0 to 50 °C, Stored: -20 to 70 °C (No condensation or freezing)		
	Operating humidity range	Operation/Stored: 35 to 85% RH (No condensation)		
	Withstand voltage	1000 VAC or more (in 50/60 Hz) for 1 minute between terminals and housing		
	Insulation resistance	2 MΩ or more at 500 VDC, between terminals and housing		
Piping spec.	Piping option C	Supply port	Rc1/8	
		Detection port	φ4 One-touch fitting	φ6 One-touch fitting
	Piping option F	Supply port	G1/8 (ISO1179-1)	
		Detection port	G1/8 (ISO1179-1)	

Model		ISA3-F	ISA3-G	ISA3-H
Lead wire	Lead wire with connector	M12 lead wire with 4 pin connector, 4 cores, ϕ 4, 5 m Conductor O.D.: 0.72 mm, Insulator O.D.: 1.14 mm		
	Centralized lead wire	M12 lead wire with 4 pin connector part, 4 cores, ϕ 4, Insulator O.D.: 1.14 mm Centralized lead wire part, 2 to 3 stations: 8 cores, ϕ 6, 5 m 4 to 6 stations: 14 cores, ϕ 6, 5 m Conductor O.D.: 0.50 mm, Insulator O.D.: 1.00 mm (2 to 6 stations common)		
Weight		113 g (Lead wire not included, One-touch fitting)		
Standard		CE marked (EMC directive/RoHS directive)		

- *1: Refer to the Characteristics Curve on page 20 for the relationship between the display value and the detected distance.
- *2: For ISA3-F type, the range is up to 57, with a hysteresis of 3.
For ISA3-G type, the range is up to 280, with a hysteresis of 20.
For ISA3-H type, the range is up to 480, with a hysteresis of 20.
- *3: The Pressure value will be indicated on the sub screen.
- *4: Refer to page 28 for details of the detection nozzle.
- *5: When OUT2 is set to distance detection.
- *6: When OUT2 is set to pressure detection.
- *7: If the pressure fluctuates around the set value, the hysteresis must be set to a value more than the amount of fluctuation, otherwise chattering will occur.
- *8: Applies only to the digital gap checker body excluding the control unit.

■ Specifications (Regulator)

Refer to the standard regulator catalogue for detailed specifications.

■ Specifications (2 port solenoid valve)

Refer to "Option/Part number" (page [12](#)) or the catalogue of the standard 2 port solenoid valve for the detailed specifications of models other than X276.

■ Characteristics graph

○ Supply pressure dependence characteristics

The detection distance for turning ON the output depends on the supply pressure.

The graphs below show the variation of the distance for the product to turn ON, for 3 types of gap, by changing the supply pressure (± 50 kPa) when the product is set to turn ON at 150 kPa supply pressure.

Test conditions	Detection nozzle: $\phi 1.5$ Piping: F type: $\phi 4 \times \phi 2.5$ tube G, H type: $\phi 6 \times \phi 4$ tube Reference pressure: 150 kPa
-----------------	--

*: Use within the rated pressure range (100 kPa to 200 kPa).

It will be impossible to measure the gap when the operating pressure is less than 80 kPa or more than 220 kPa and the output will be OFF. (Refer to the relationship between the supply pressure and display on page 67.)

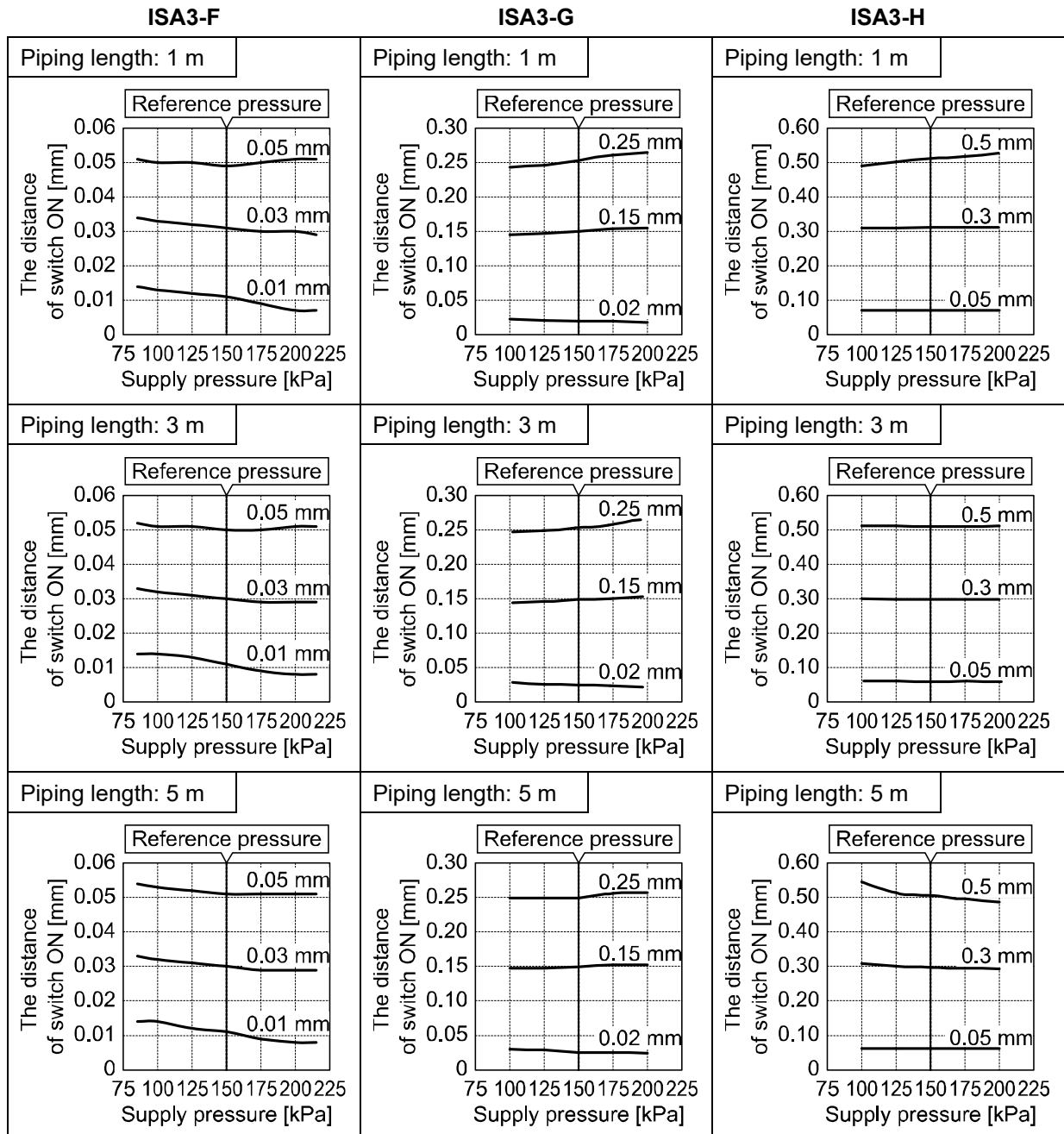

○ Response time

Response time is the elapsed time between the pressure supply and the turning ON of the switch output. The Response time varies depending on the piping length from the OUT port to the detection nozzle, and the seating condition of the workpiece.

The graphs below show the response time when the workpiece is approached at 90% distance and 0% distance (close contact). (*: The switch point is 100% distance)

(Example: When the switch point is set to 0.1 mm, the response time when the workpiece is at 0.09 mm and 0.00 mm are measured).

Test conditions	Detection nozzle: $\phi 1.5$ Piping: F type: $\phi 4 \times \phi 2.5$ tube G, H type: $\phi 6 \times \phi 4$ tube Supply pressure: 200 kPa
-----------------	---

— Response time when the workpiece is set at 90% distance.
— Response time for close contact of workpiece.

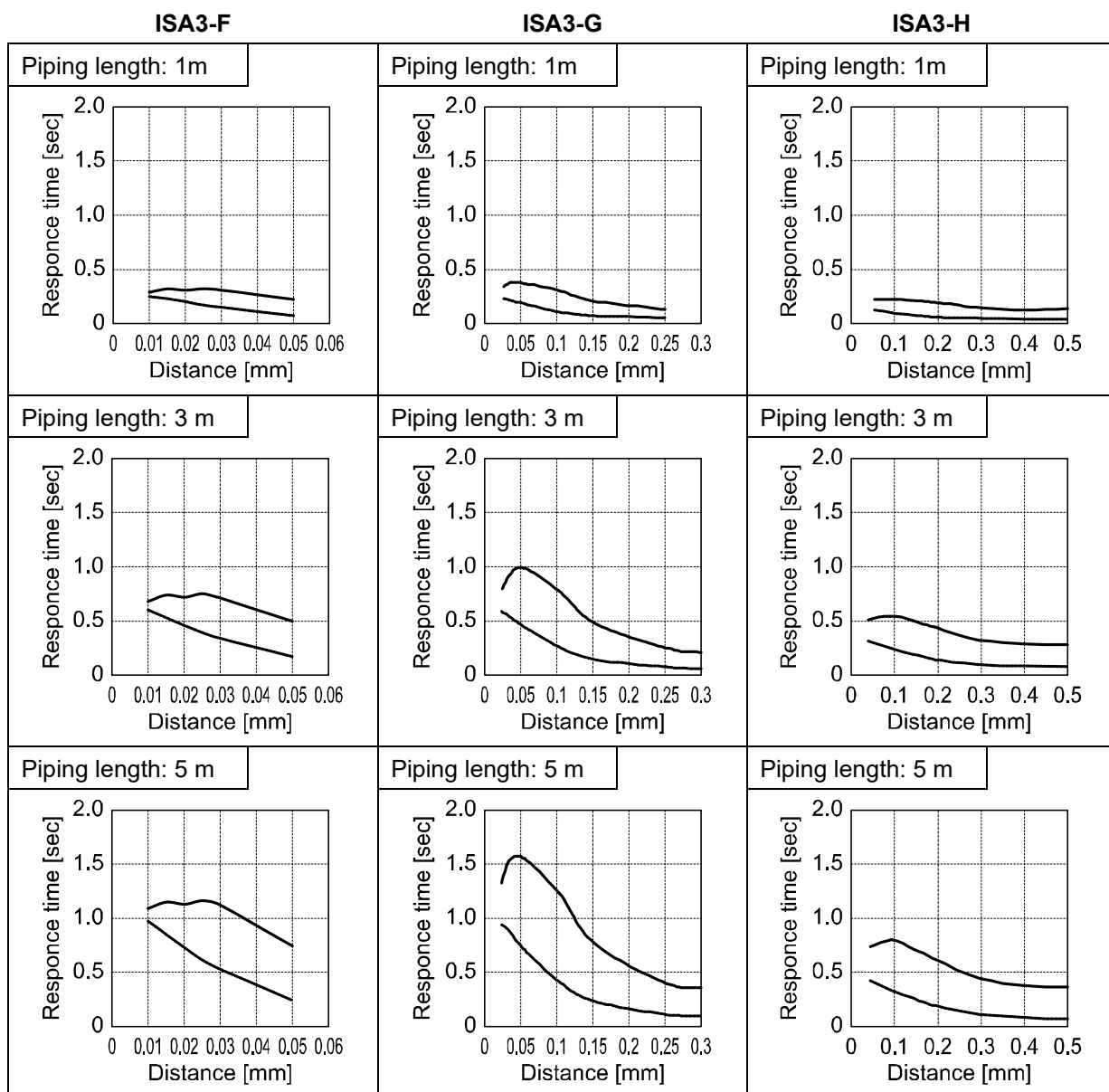

○ Relationship between the display value (switch point) and distance

The graphs below show the relationship between [display value (switch point) on the sub screen] and [the actual distance between the detection surface and the workpiece].

*: The values in the table are for reference only). The values will vary depending on the individual product difference and nozzle machining dimensions.

Test conditions	Detection nozzle: $\phi 1.5$ Piping: F type: $\phi 4 \times \phi 2.5$ tube 1 m, 3 m, 5 m G, H type: $\phi 6 \times \phi 4$ tube 1 m, 3 m, 5 m Supply pressure: 200 kPa
-----------------	---

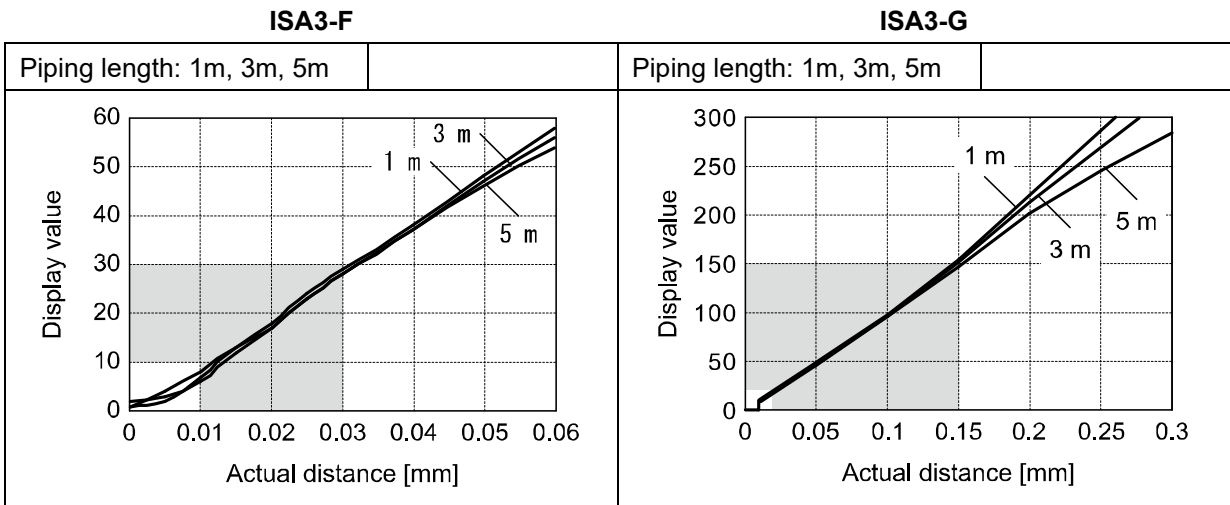

*: When the display value becomes 9 or lower, "0" is displayed.
 "0" and "10" are displayed near "10". This does not affect the performance.

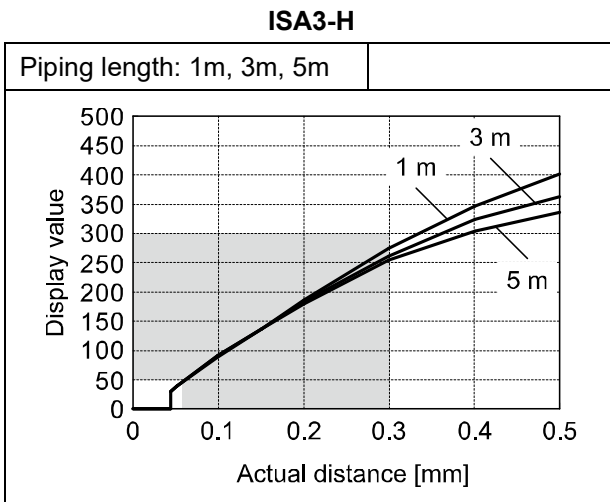

*: When the display value becomes 29 or lower, "0" is displayed.
 "0" and "30" are displayed near "30". This does not affect the performance.

■ Dimensions

●ISA3-□□ (Without control unit, Bracket mounting)

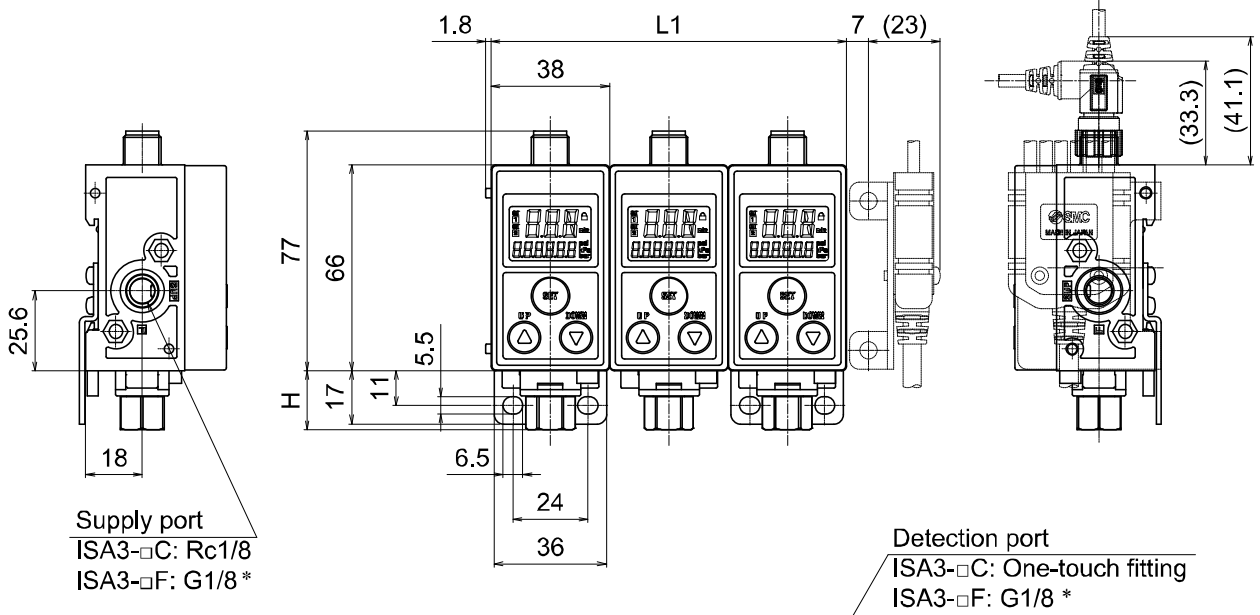

*: ISO1179-1

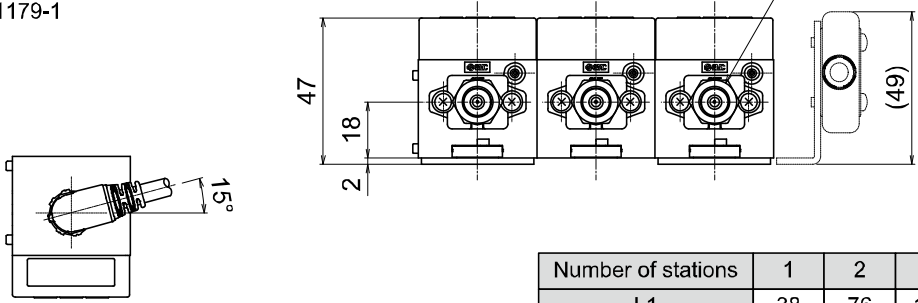

When centralized lead wire is used.

Number of stations	1	2	3	4	5	6
L1	38	76	114	152	190	228

Piping specifications	C (φ4 One-touch fitting)	C (φ6 One-touch fitting)	F (G-thread (screw))
H	13	13.6	19

●ISA-14 (Bracket when control unit not fitted)

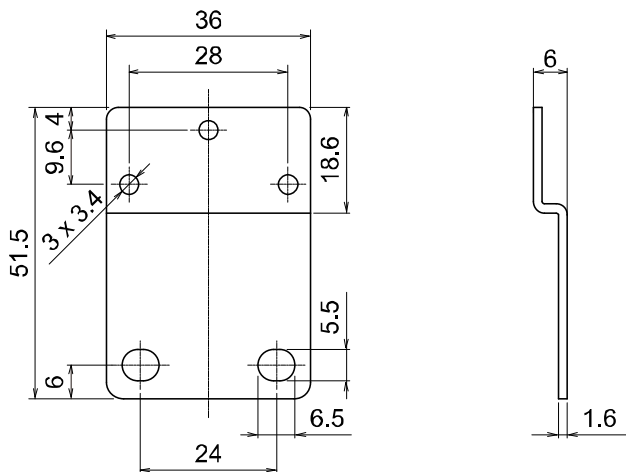

•ISA3-□□ (Without control unit, DIN rail mounting)

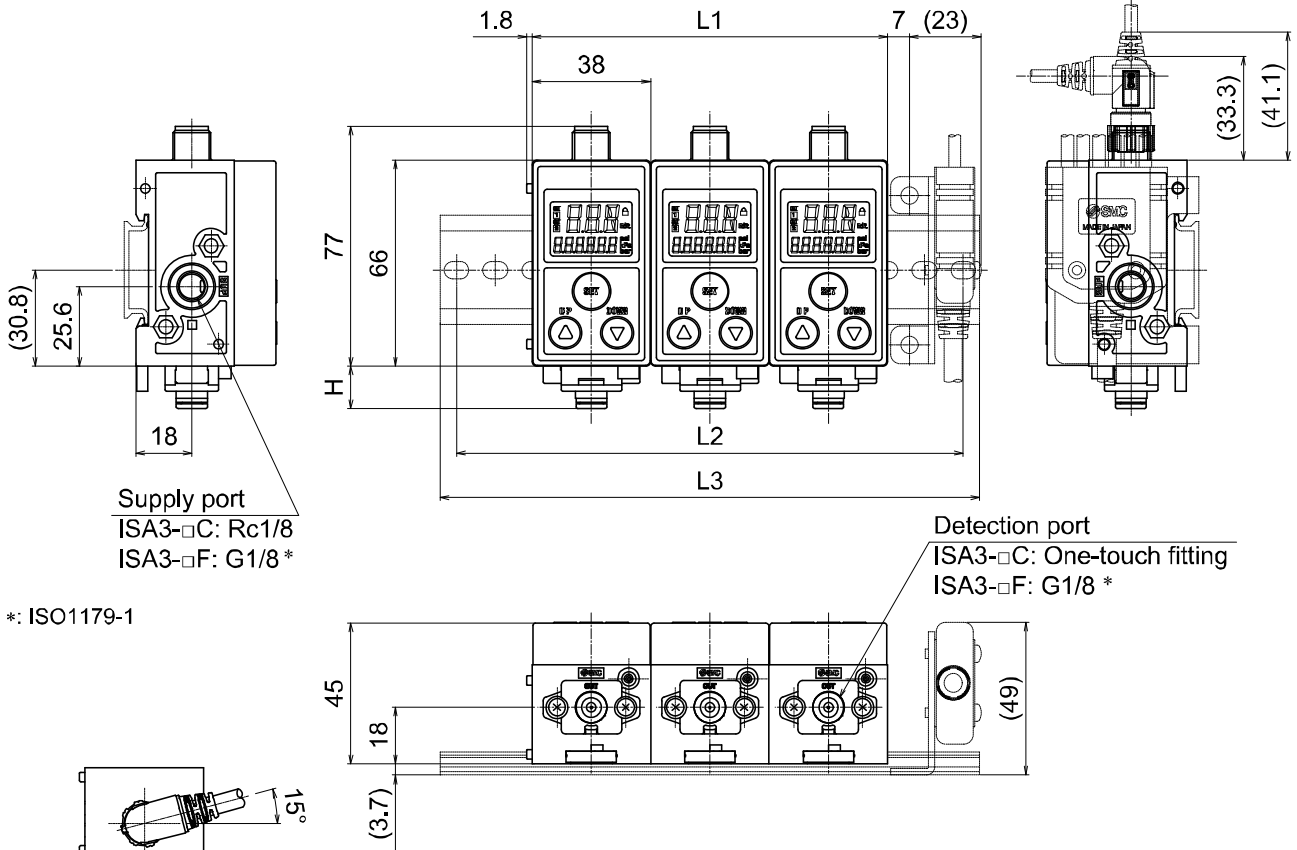

*: ISO1179-1

When centralized lead wire is used.

Number of stations	1	2	3	4	5	6
L1	38	76	114	152	190	228
L2	62.5	125	162.5	200	237.5	275
L3	73	135.5	173	210.5	248	285.5

Piping specifications	C (φ4 One-touch fitting)	C (φ6 One-touch fitting)	F (G-thread (screw))
H	13	13.6	19

•ISA3-□□□-□□□ B-L □ (With control unit, Bracket mounting)

•Regulator

Round pressure gauge

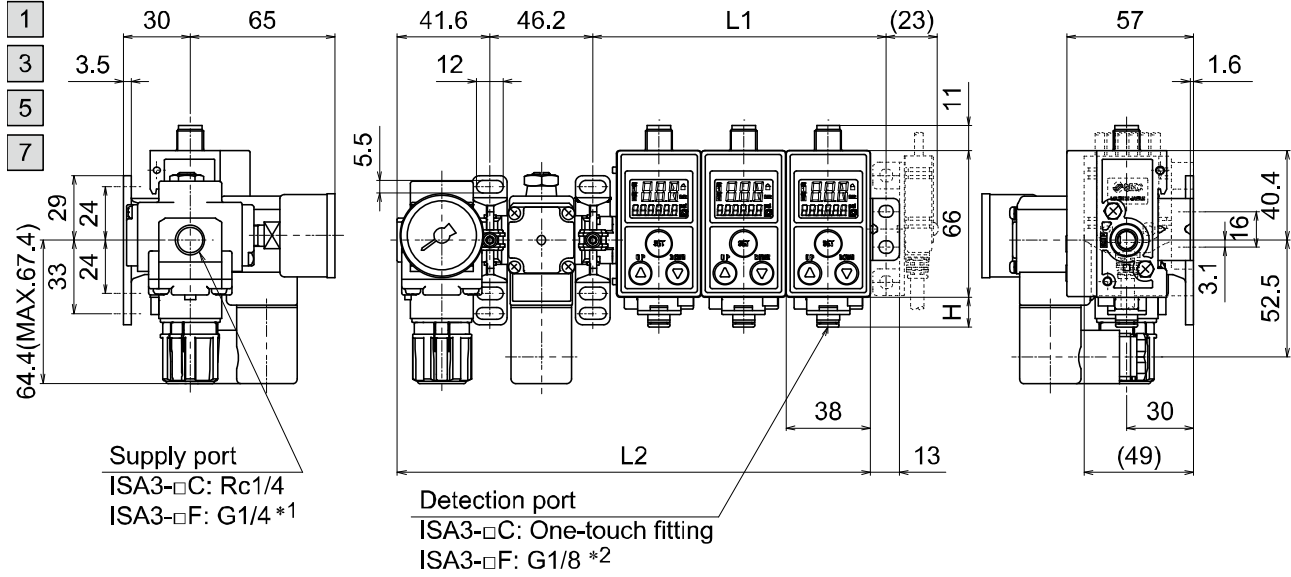

•ISA3-□□□-□□□ B-L □

•Regulator

Without pressure gauge

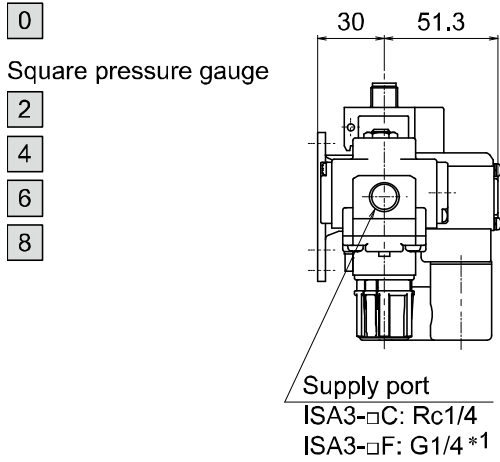

*: Only bracket mounting is applicable for use with a control unit.

*1: ISO16030
*2: ISO1179-1

Number of stations	1	2	3	4	5	6
L1	55.6	93.6	131.6	169.6	207.6	245.6
L2	136.4	174.4	212.4	250.4	288.4	326.4

Piping specifications	C (φ4 One-touch fitting)	C (φ6 One-touch fitting)	F (G-thread (screw))
H	13	13.6	19

•ISA3-□□□-□□□ B-R□□

Regulator

Round pressure gauge

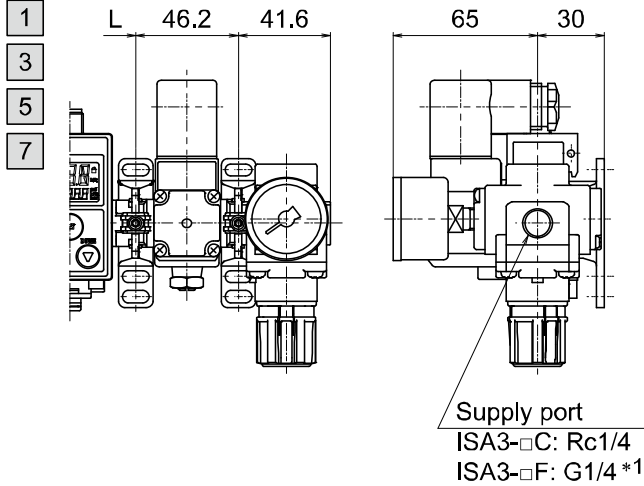

•ISA3-□□□-□□□ B-R□□

Regulator

Without pressure gauge

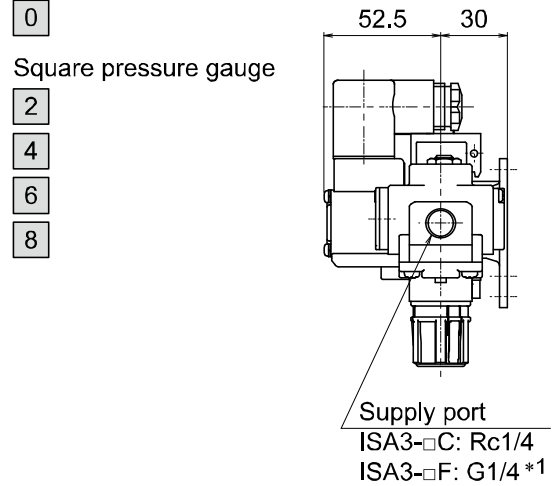

•ISA3-□□□-□□□-B-LN□

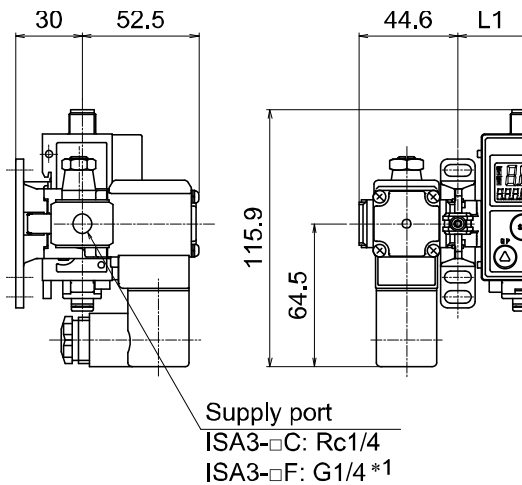

•ISA3-□□□-□□□-B-RN□

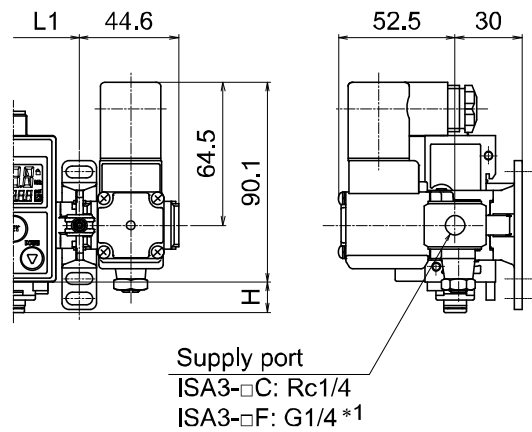

*: Only bracket mounting is applicable for use with a control unit.

*1: ISO16030

*2: ISO1179-1

Number of stations	1	2	3	4	5	6
L1	55.6	93.6	131.6	169.6	207.6	245.6

Piping specifications	C (φ 4 One-touch fitting)	C (φ 6 One-touch fitting)	F (G-thread (screw))
H	13	13.6	19

•ISA-17 (Bracket when control unit fitted)

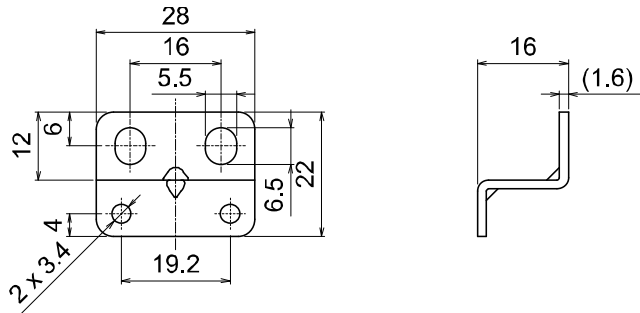

•Y200T-A (Spacer with bracket)

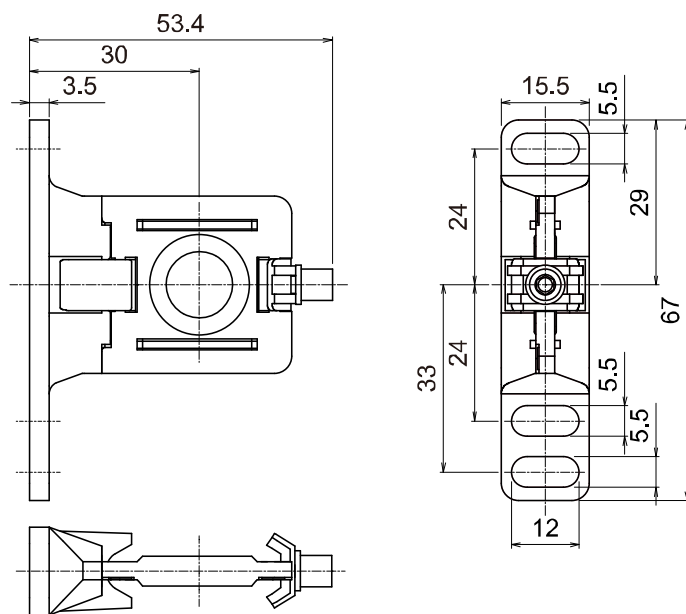

•ISA-20 (Bracket for centralized lead wire)

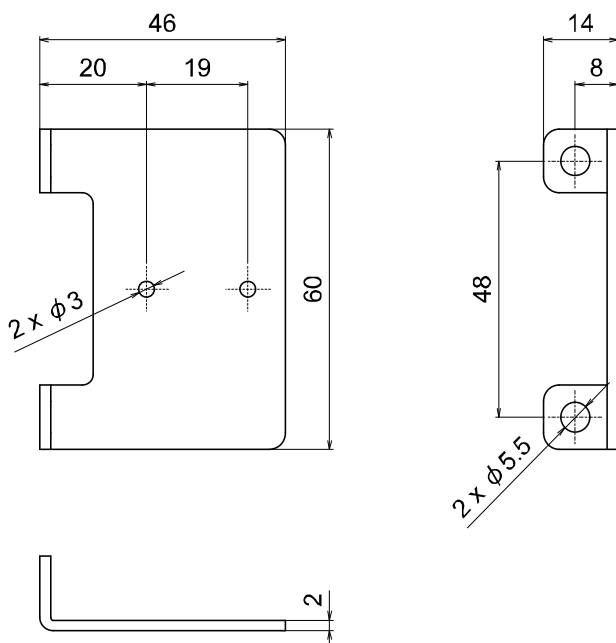

•ZS-31-B (Lead wire with connector (Straight))

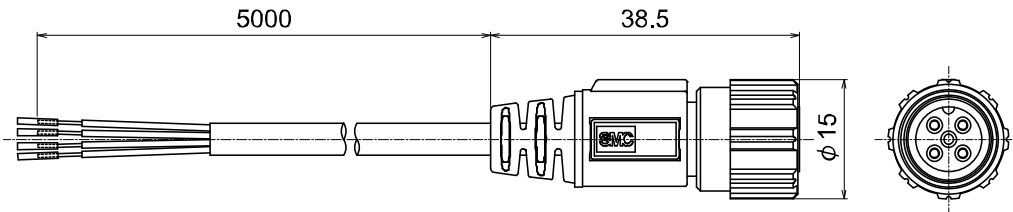

•ZS-31-C (Lead wire with connector (Right angle))

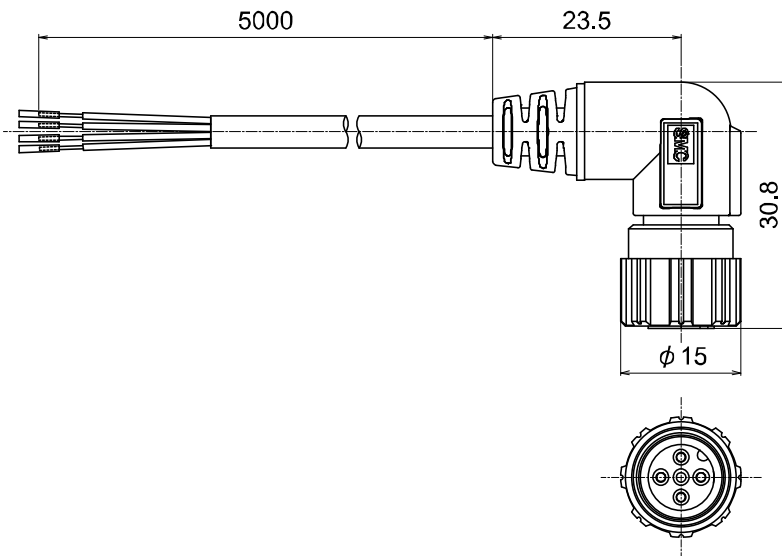

•ISA-21-□ (Centralized lead wire)

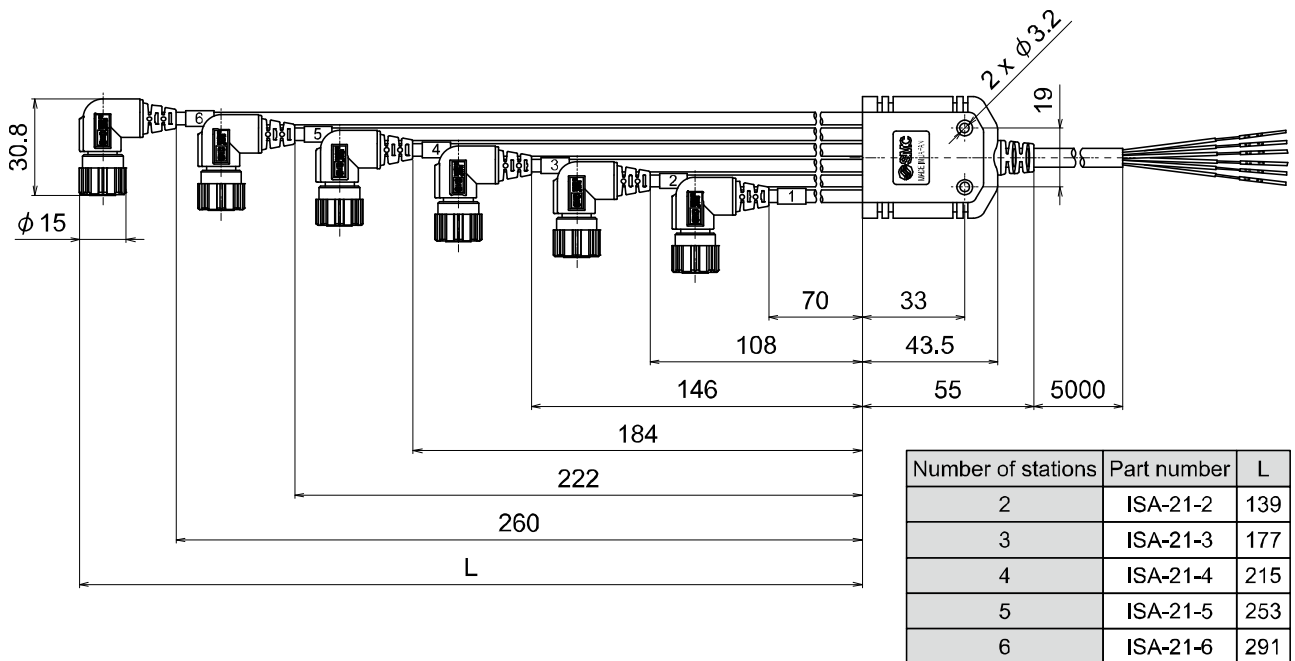

Mounting and Installation

■ Piping

○ SUP port (supply port)

- Use the correct tightening torque. Refer to the following table for the appropriate tightening torque.
- Fit the seal plug (supplied with the product) to the unused port.

Product	Nominal thread size	Proper tightening torque (N•m)	Product	Nominal thread size	Proper tightening torque (N•m)
ISA3	Rc1/8 • G1/8	3 to 5	Regulator	Rc1/4 • G1/4	8 to 12

○ OUT port (detection port)

- Use the correct tightening torque. Refer to the following table for the appropriate tightening torque.

Nominal thread size	Proper tightening torque (N•m)
G1/8	3 to 5

- For $\varnothing 4$ one-touch fitting, use tube with O.D. 4 mm, and I.D. 2.5 mm.
- For $\varnothing 6$ one-touch fitting, use tube with O.D. 6 mm, and I.D. 4 mm.

⚠ Warning

- Do not use equipment or fittings that may leak or obstruct the air flow between the product and the detection nozzle.
- The product should be positioned higher than the detection nozzle.

If the product is positioned lower than the detection nozzle, water or oil may enter the detection port, causing a malfunction or operational failure.

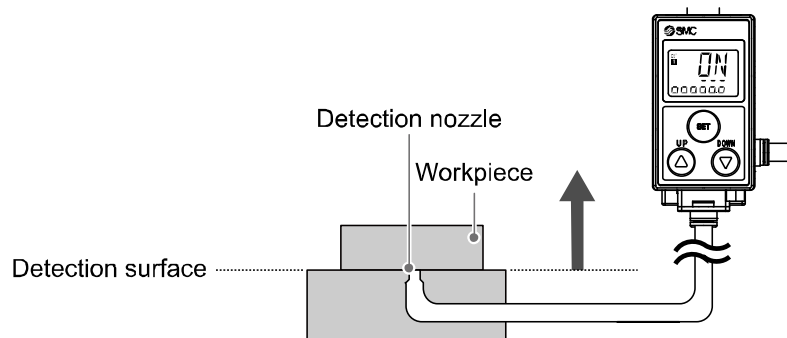

○ Atmospheric vent port

- Connect tubing (sold separately) to the atmospheric vent port if there is a possibility that the port could be blocked by water or dust.
- Recommended tube is TU0425 (material: polyurethane, O.D. $\varnothing 4$, I.D. $\varnothing 2.5$) made by SMC.
- The other end of the air tubing should be routed to a safe place to prevent it from being exposed to water or dust.
- Ensure the tubing has no sharp bends.

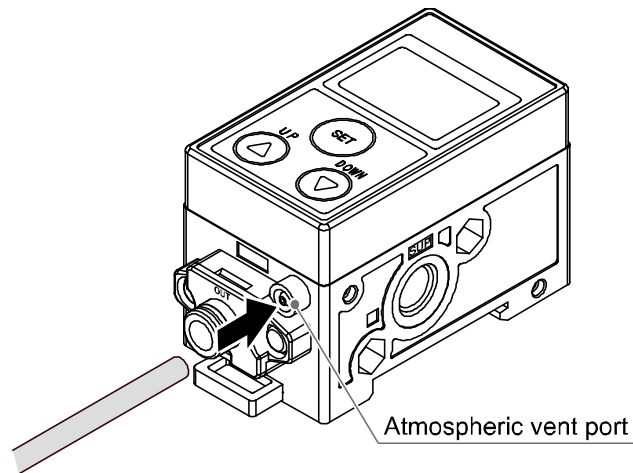

○ Detection Nozzle shape

The Nozzle shape must be similar to Figure 1.

Do not chamfer the nozzle as shown in Figure 2, as the characteristics will be affected.

Fig.1: Recommended nozzle shape

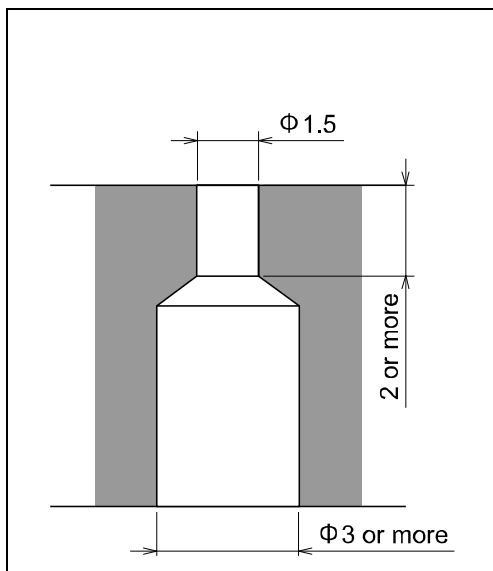
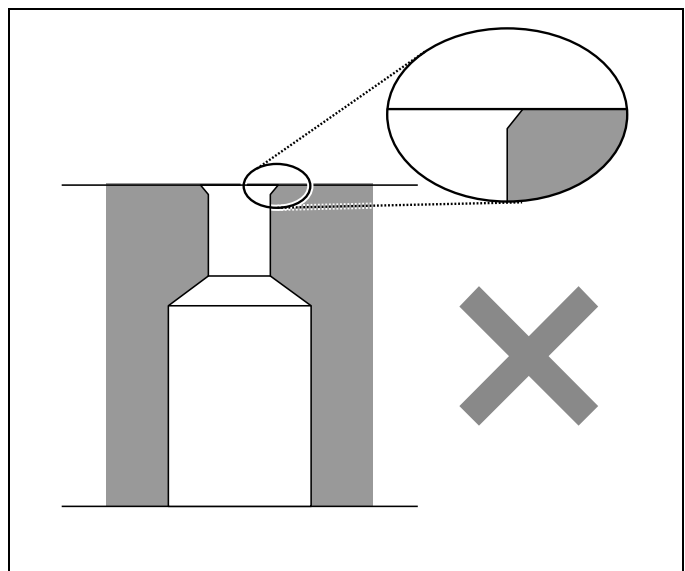

Fig.2: Unsuitable nozzle shape



○ Restrictor setting of 2 port solenoid valve

Air can be continuously supplied by adjusting the restrictor. This reduces the possibility of water or cutting oil etc. entering the 2 port solenoid valve from the OUT port (detection port).

- Turn off the power to the 2 port solenoid valve.
- Adjust the restrictor by turning the screw with a flat head screw driver etc.

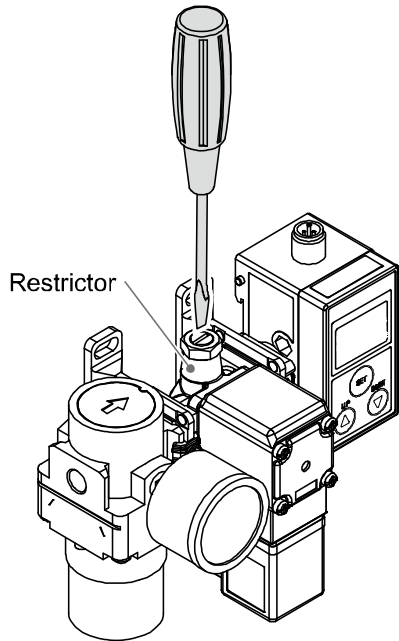

Clockwise: Restrictor closed
Counterclockwise: Restrictor opened

*: Do not turn the restrictor screw more than 5 rotations from the fully closed position as the screw will come out.

- Turn on the 2 port solenoid valve. Check that no water or cutting oil etc. is exhausted from the detection nozzle.
- When water or cutting oil etc. is exhausted, turn the restrictor screw in a clockwise direction (closing).

■ Installation

*: Connect piping before mounting to the DIN rail or bracket.

- (1) If the piping is connected while a bracket for single unit or DIN rail is mounted, the bracket or DIN rail might be bent.
- (2) If the piping is connected while the display is held with a vice, the display might be damaged.
- (3) If a tool comes into contact with the boss, it might be broken. Therefore, connect the piping carefully.

○ DIN rail

Mounting

- (1) Hook the claw part 1 to the DIN rail.
- (2) Push the claw part 2 down until it clicks.

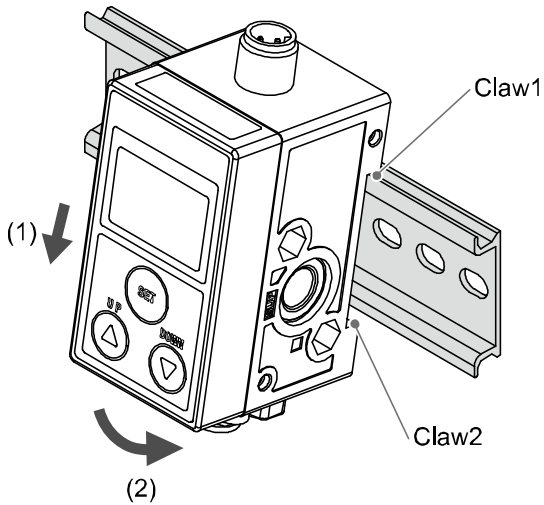

Removal

- (1) Pull the DIN rail mounting latch downward for unlocking.
- (2) Pull out the OUT port (detection port) side.

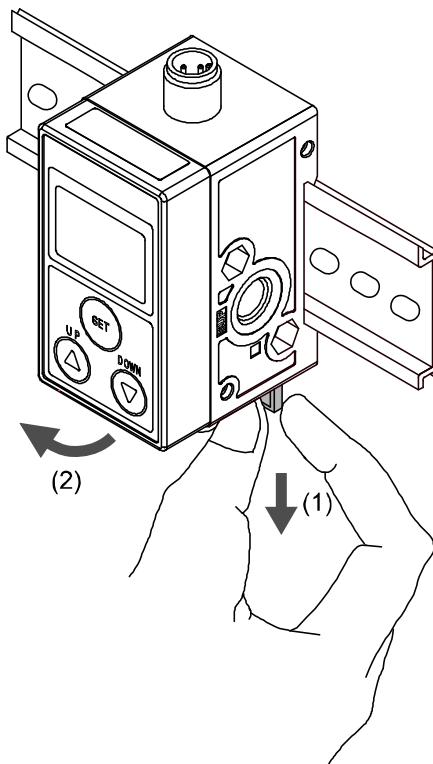

○ Bracket

- Mount the bracket using the mounting screws supplied.
- The tightening torque of the mounting screw must be $0.45 \text{ N}\cdot\text{m} \pm 10\%$.

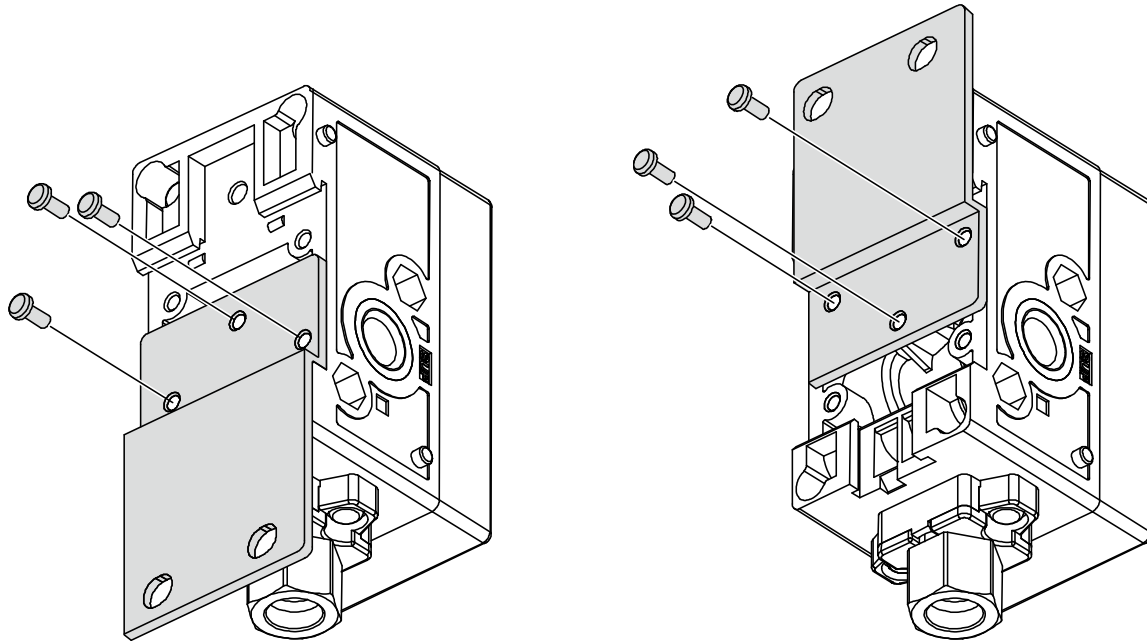

- When the product is mounted using the bracket, fix with M5 screws (2 pcs.) or equivalent.
- The Bracket thickness is approx. 1.6 mm.
- Refer to the bracket dimension drawing (page 21) for the mounting hole dimensions.

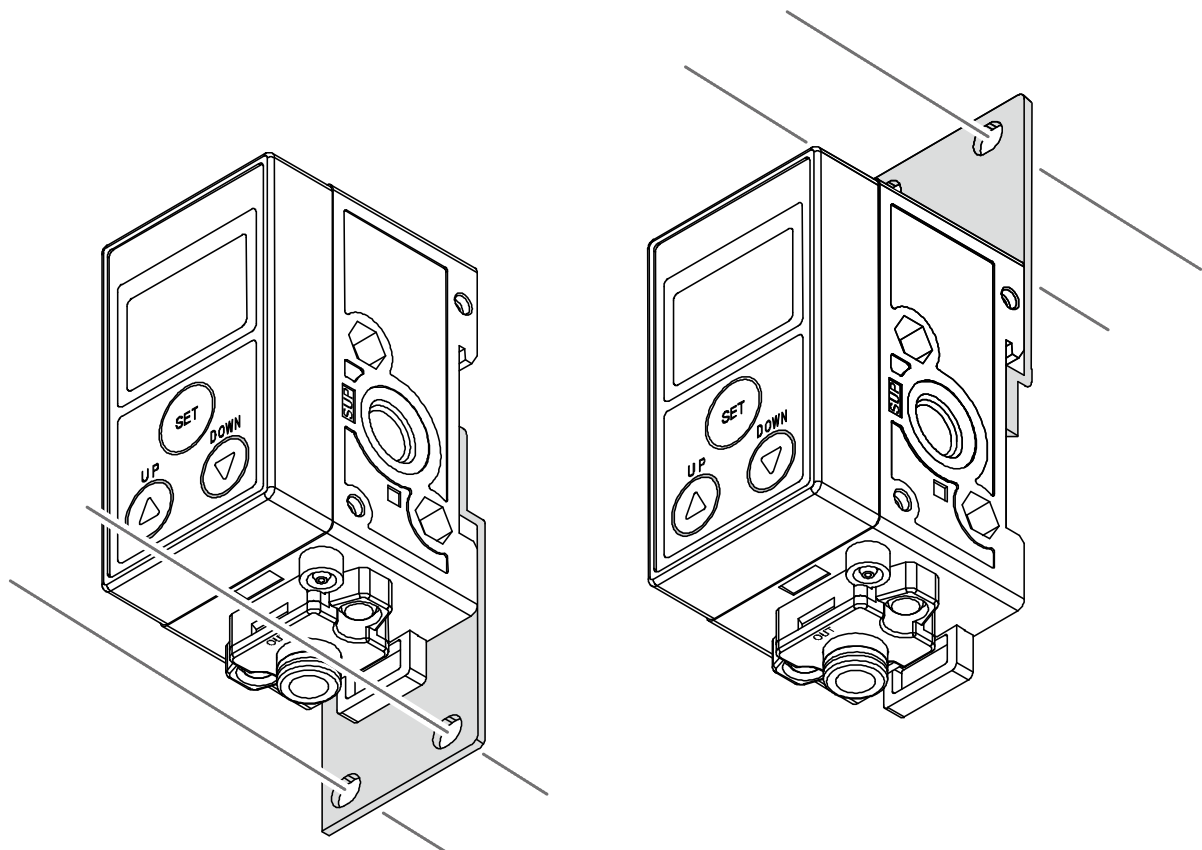

•Mounting position of the bracket

2 stations
(Mount to 1st. and 2nd. station)

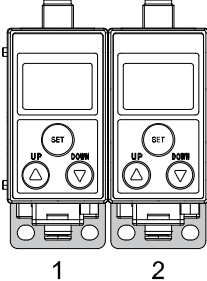

n stations
(Mount to 1st. and nth. station)

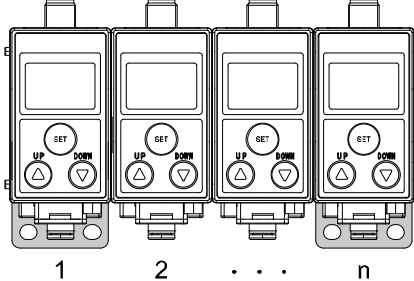

○ Bracket (when control unit fitted)

- When a product with control unit is ordered, the bracket will be mounted to the product before shipment.

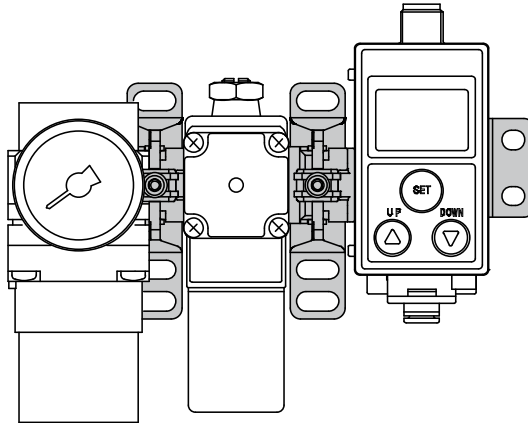

- Mount the spacer with bracket using an M5 mounting screw or equivalent.
- Thickness of the spacer with bracket is approximately 3.5 mm.
- Refer to the "Bracket mounting" dimensions (page 23) for the mounting hole dimensions.

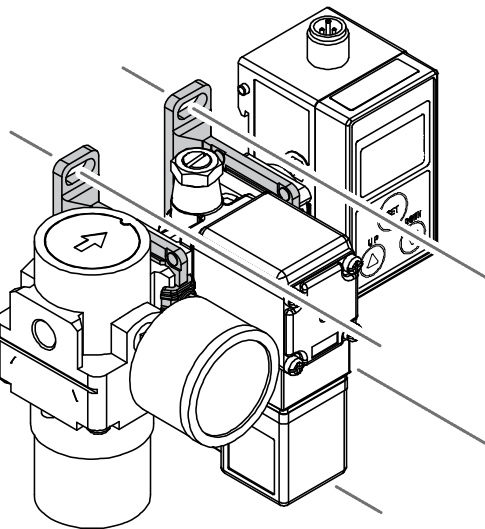

- Mount the bracket using M5 mounting screws (2 pcs.) or equivalent.
- The bracket plate thickness is approximately 1.6 mm.
- Refer to the "Bracket mounting" dimensions (page 23) for the mounting hole dimensions.

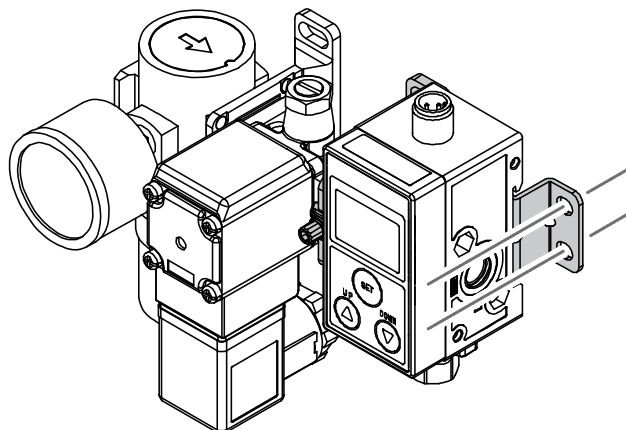

○ **Assembly procedure to increase/decrease the number of product.**

- Remove the joint screws of product using a Phillips head screwdriver and separate the Product body.

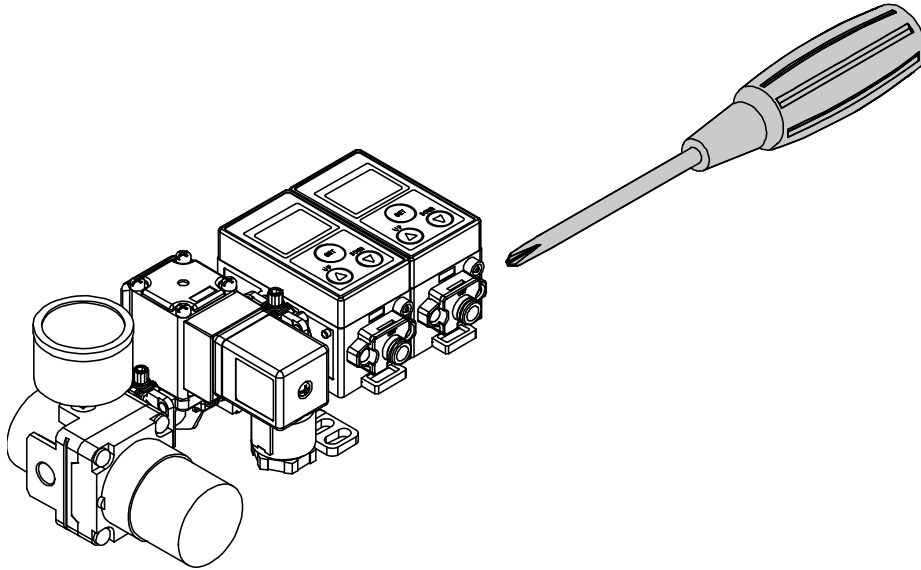

*: Take care not to lose the seals.

- Insert a product and the seal for extra station (ISA-15) between the products to increase the number of stations.
- Remove a product and the seal from the products to decrease the number of stations.

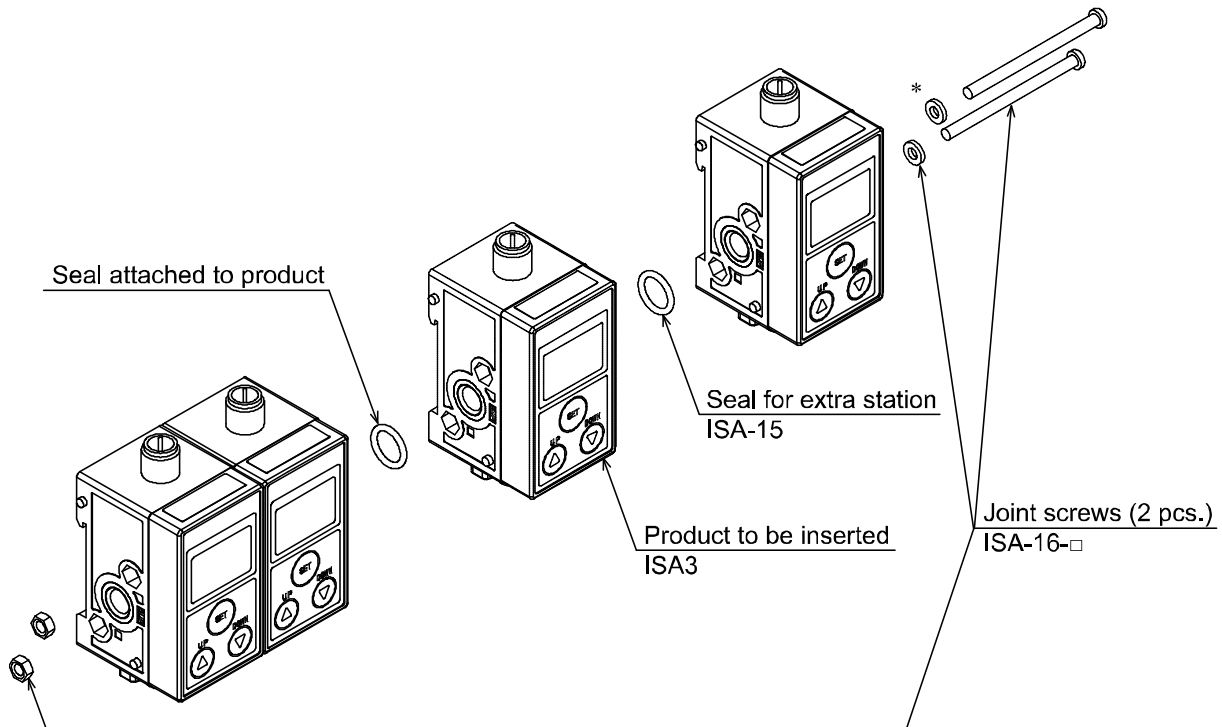

*: Spacers are included for 4 and 6 stations.

- Connect the products using the joint screws. (Tightening torque: 0.75 N•m ±10%)

■ Wiring

○ Mounting and removal of connector

- Tighten the connector by hand.
- Align the body connector key and the lead wire connector key groove to insert vertically.
- Turn the knurled part of the lead wire side connector clockwise.
- Connection is complete when the knurled part is fully tightened. Check that the connection is not loose.

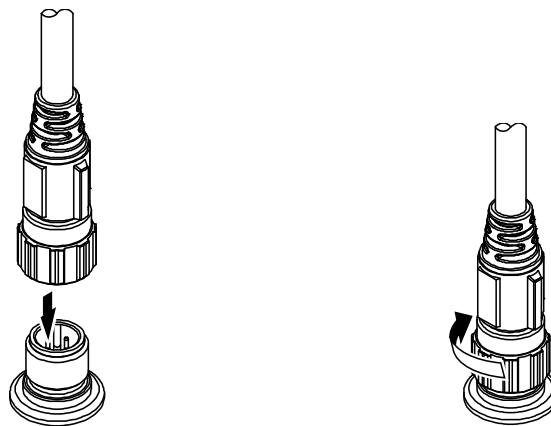

○ Connector pin No. (Body side)

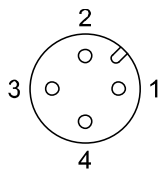

Connector pin No.	Description
1	DC(+)
2	OUT2
3	DC(-)
4	OUT1

○ Connector pin No. (Lead wire side)

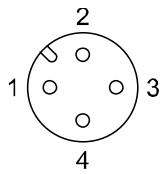

Connector pin No.	Lead wire colour	Description
1	Brown	DC(+)
2	White	N.C.
3	Blue	DC(-)
4	Black	OUT1

● ZS-31-B (Lead wire with connector)

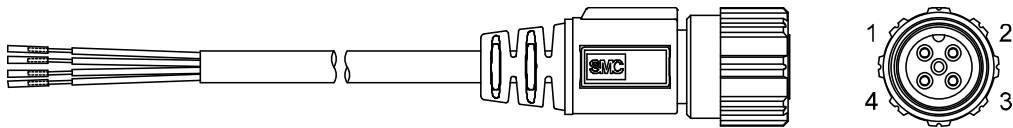

● ZS-31-C (Lead wire with connector)

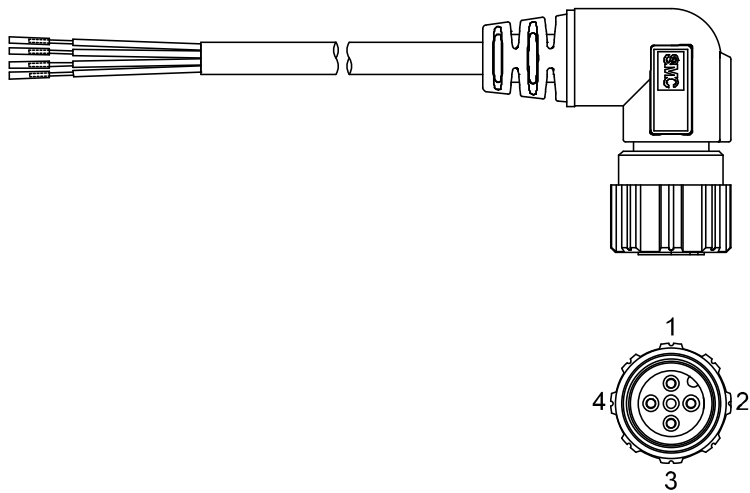

•ISA-21-□ (Centralized lead wire)

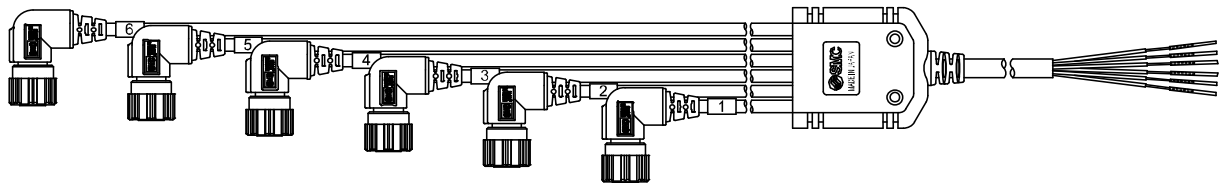

Pin layout

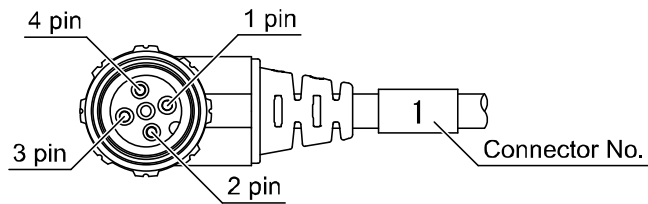

ISA-21-2/3 (8 cores)

Connector No.	Pin No.	Color
1	1	DC(+): Brown
	2	OUT2: Orange
	3	DC(-): Blue
	4	OUT1: Black
2	1	OUT2: Red
	2	OUT1: White
	3	OUT2: Green
	4	OUT1: Gray

ISA-21-4/5/6 (14 cores)

Connector No.	Pin No.	Color
1	1	DC(+): Brown
	2	OUT2: Yellow
	3	DC(-): Blue
	4	OUT1: Black
2	1	OUT2: Purple
	2	OUT1: White
	3	OUT2: Gray/Black
	4	OUT1: Gray
3	1	OUT2: Orange/Black
	2	OUT1: Orange
	3	OUT2: Red/Black
	4	OUT1: Red
4	1	OUT2: Green/Black
	2	OUT1: Green
	3	OUT2: Gray/Black
	4	OUT1: Gray

Caution

The electrical entry of centralized lead wire for M12 connector is on the right side. If the supply port on the right side is used, arrange the centralized lead wire so that it does not interfere with the control unit.

○ **Internal circuit and wiring examples (for lead wire with connector)**

Wire the product according to the circuit diagram below.

● **ISA3-□□A**

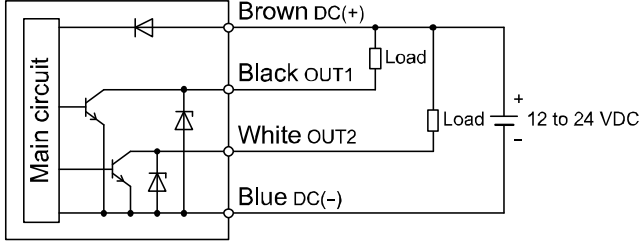

● **ISA3-□□B**

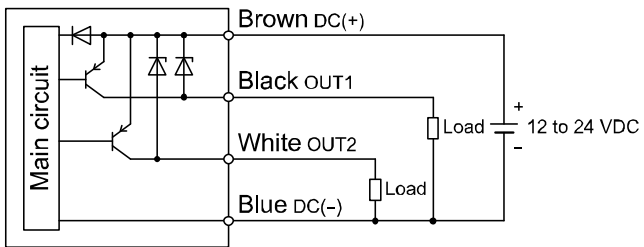

◆ Refer to the VX2 series Operation Manual for wiring details of the VX2 series (2 port solenoid valve).

■ Part structure

○ Without control unit

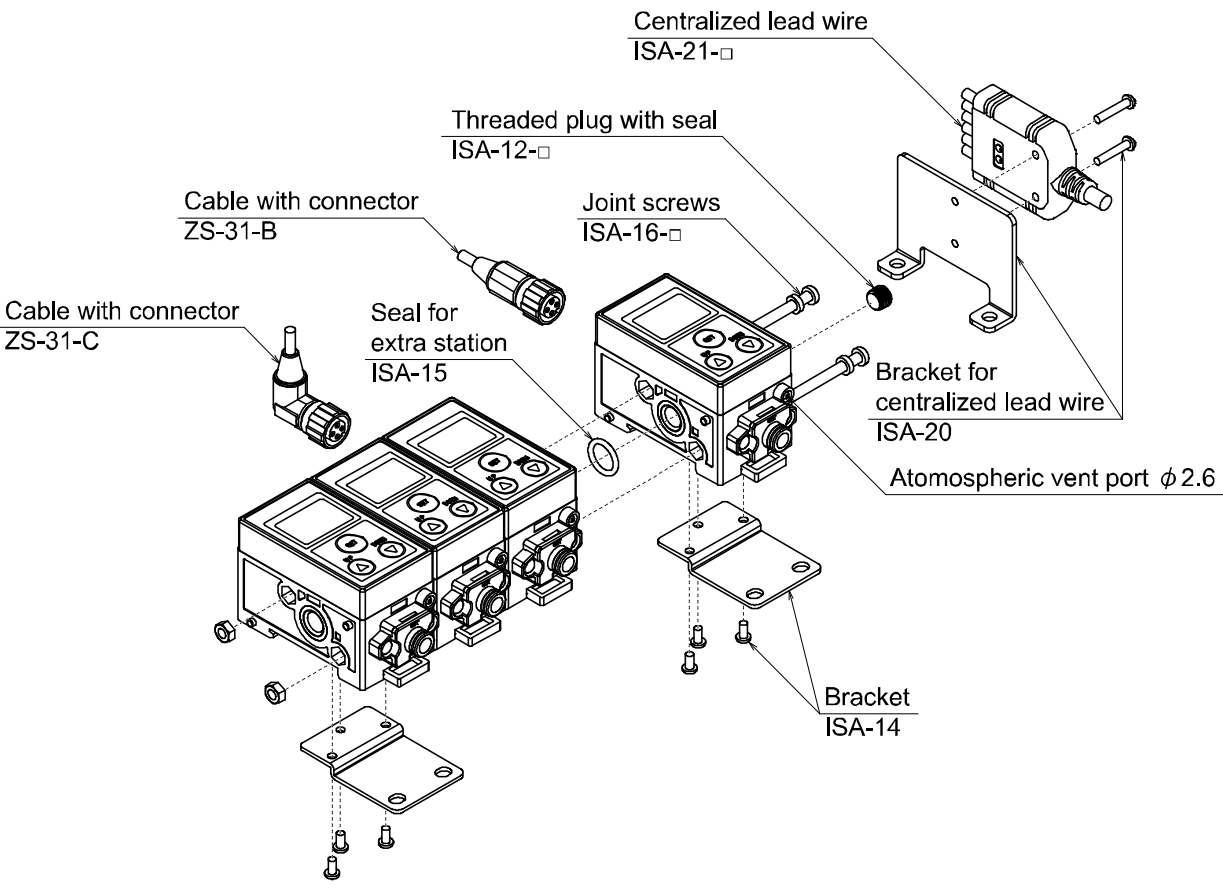

○With control unit (Supply port: Left side)

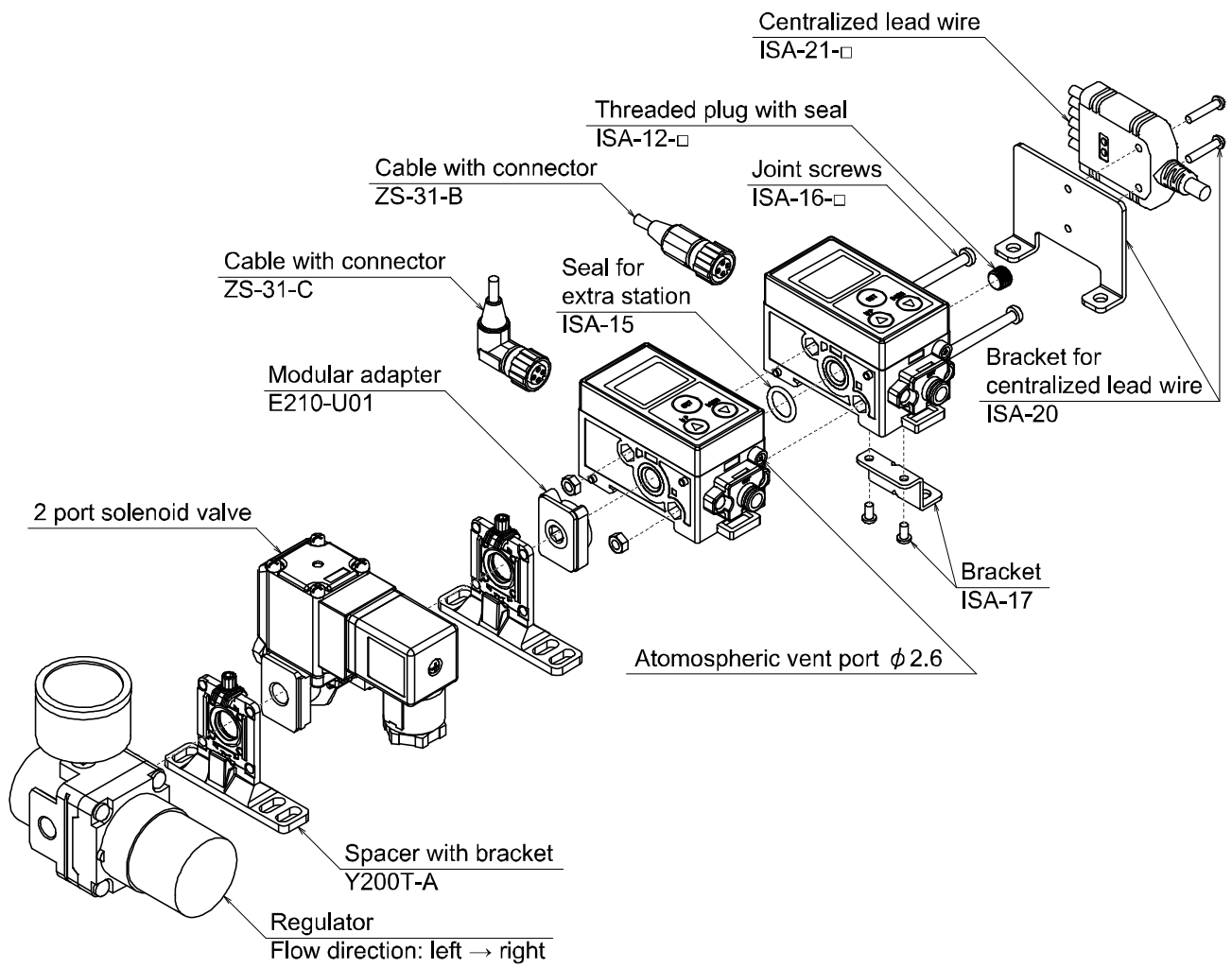

○With control unit (Supply port: Right side)

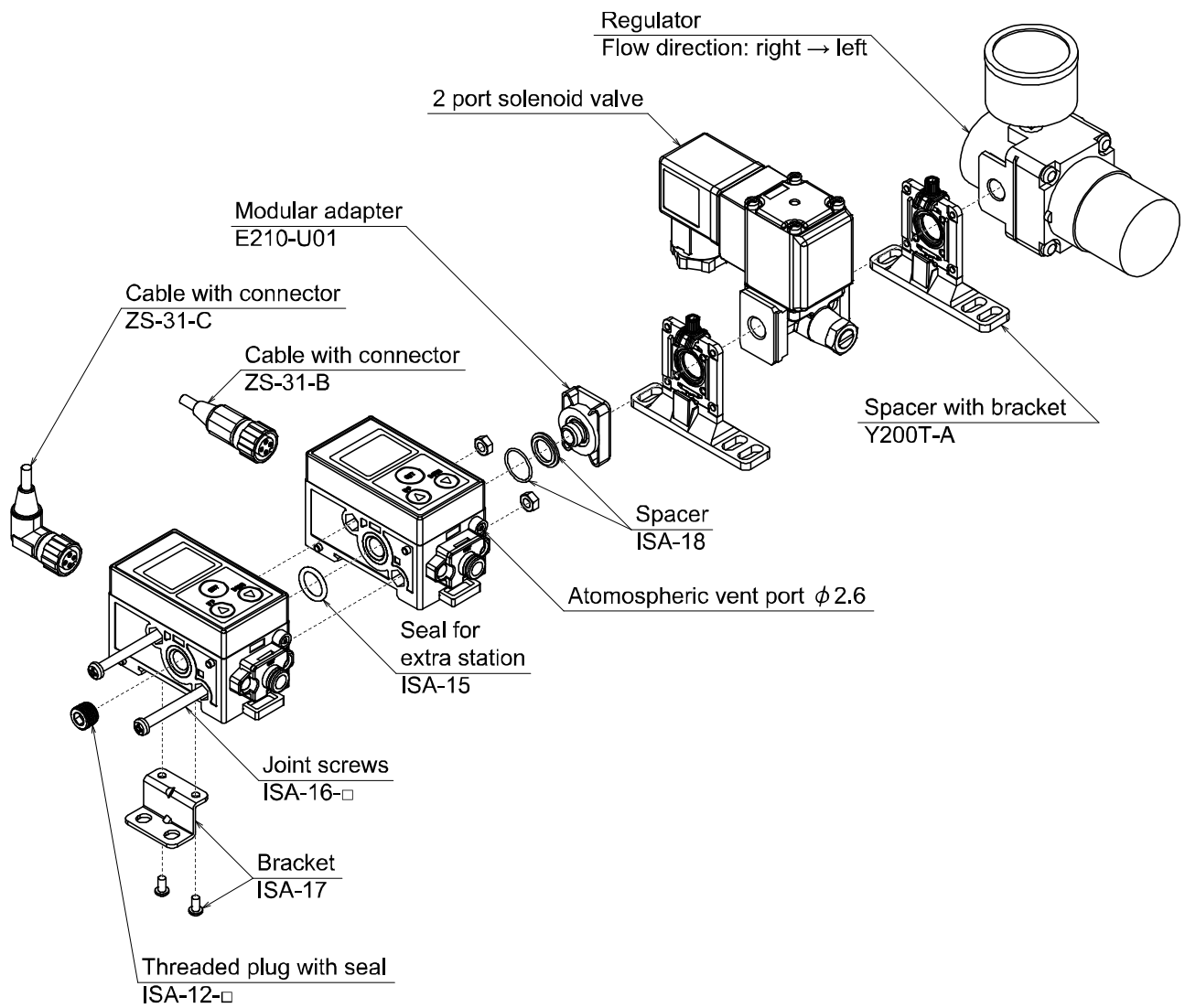

Outline of setting

Power is supplied

The identification code of the product is displayed.

Measurement mode

Measurement mode starts automatically when supply pressure is between 80 and 220 kPa.
Switch status ON or OFF will be displayed on the main screen.
Level meter will be displayed on the sub screen (default setting). *



OFF displayed

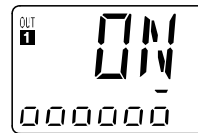

ON displayed

(Refer to page 43)

Press button once.

Press button for 2 seconds or longer.

Press button for 5 seconds or longer.

Switch point change mode

OUT:1 Switch point
OUT:2 Pressure set value/switch point can be changed.

(Refer to page 45)

Function selection mode

Each function can be changed individually.

(Refer to page 48)

Key lock mode

(Refer to page 62)

*: Parameters other than the level meter can be displayed, by selecting the parameter using function selection mode [F10]. (Refer to page 56)

■ Measurement mode

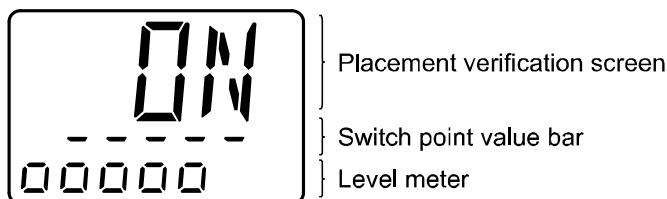

● Placement verification screen (Main screen)

The Placement condition is indicated by the switch output status (ON/OFF).

● Level meter (Sub screen)

Element	Description
Switch point value bar	A bar to indicate the switch point value which has been set, is automatically displayed. Refer to how to change the switch point value (page 45). *: OUT1: Switch point only
Level meter	The workpiece gap condition approaching the nozzle is indicated by the number of "0" displayed. This display is a reference only. It is not an accurate distance measurement.

○ Relationship between the display and the placement status (Example)

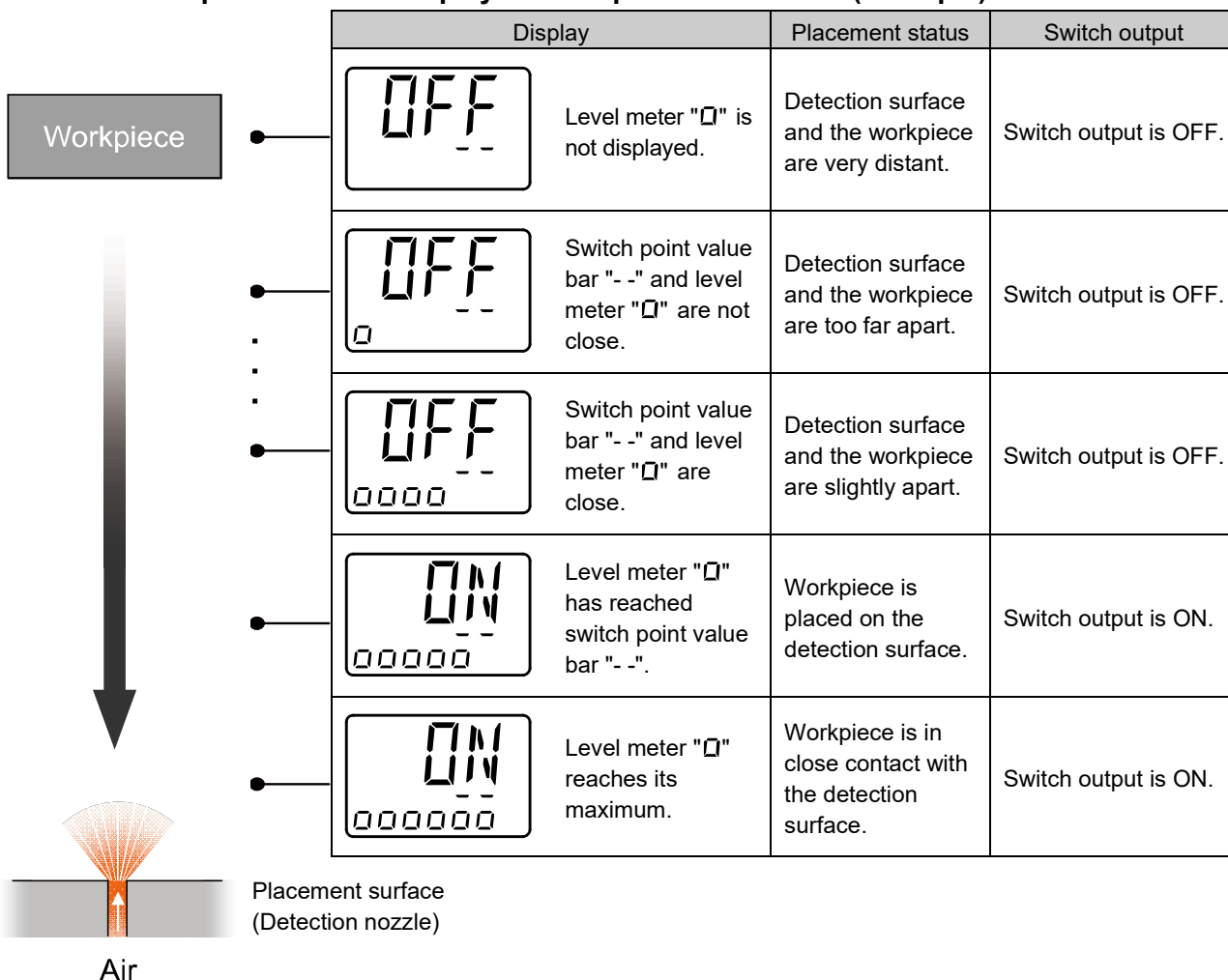

○ Change of sub screen

In measurement mode, the display of the sub screen can be temporarily changed by pressing the ▲ or ▼ buttons

30 seconds after changing, the display will automatically return to the screen set in [F10] of function selection mode. (Refer to page 56)

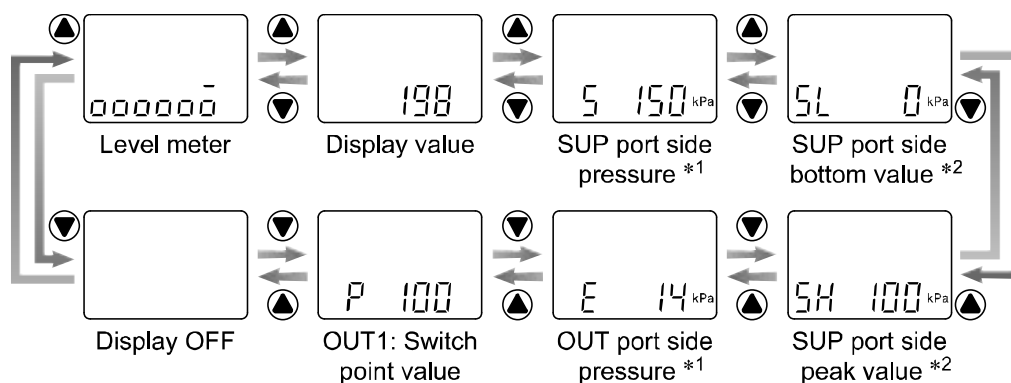

- Level meter: Displays the measured distance (reference) by figure.
- Display value: Displays the measured distance (reference) by value.
- SUP port side pressure: Displays the pressure value supplied to the SUP port (supply port). *1
- SUP port bottom value: Displays the bottom pressure value at the SUP port (supply port). *2
- SUP port peak value: Displays the peak pressure value at the SUP port (supply port). *2
- OUT port side pressure: Displays the pressure value supplied to the OUT port (detection port). *1
- Switch point value: Displays the switch point value.
- Display OFF: Displays nothing

*1: Zero-clear operation

When the SUP port pressure value or OUT port pressure value is indicated on the sub screen, the display can be cleared to zero [0 kPa] by pressing the ▲ and ▼ button for 1 second or longer at atmospheric pressure.

*2: Peak/bottom clear operation

When the SUP port peak or bottom value is displayed on the sub-screen, the display can be cleared by pressing ▲ and ▼ buttons for 1 second or more.

Switch Point Setting

■ OUT1: Switch point OUT2: Pressure set value/switch point changing mode

OUT1: Switch point OUT2: Pressure set value/switch point can be changed in this mode.

To change the hysteresis etc., refer to the function selection mode on page 50.

OUT2 is set to pressure setting mode (pressure detection mode) as a default. When changing to switch point setting mode (distance setting mode), set in the function selection mode (page 52).

■ Default settings of OUT1

Refer to the figure below for the default settings of OUT1.

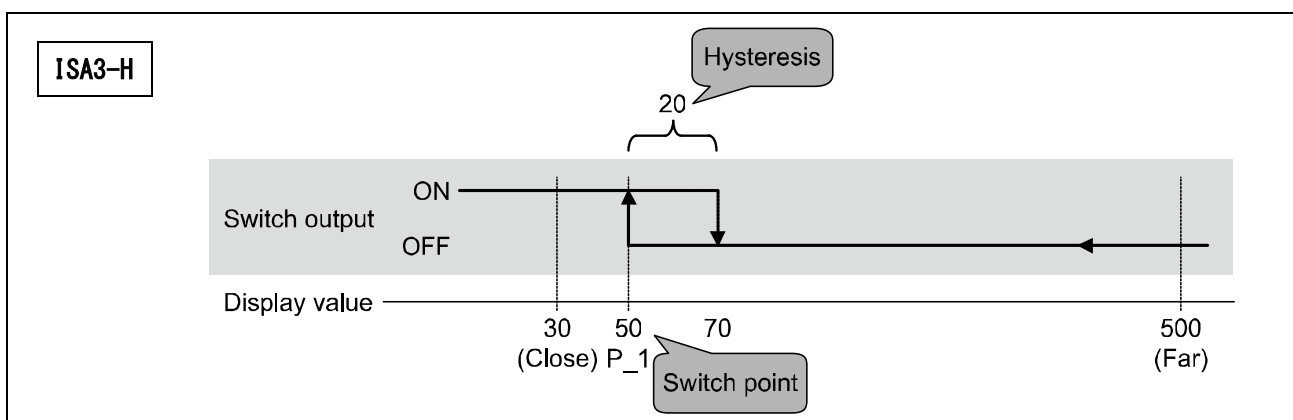
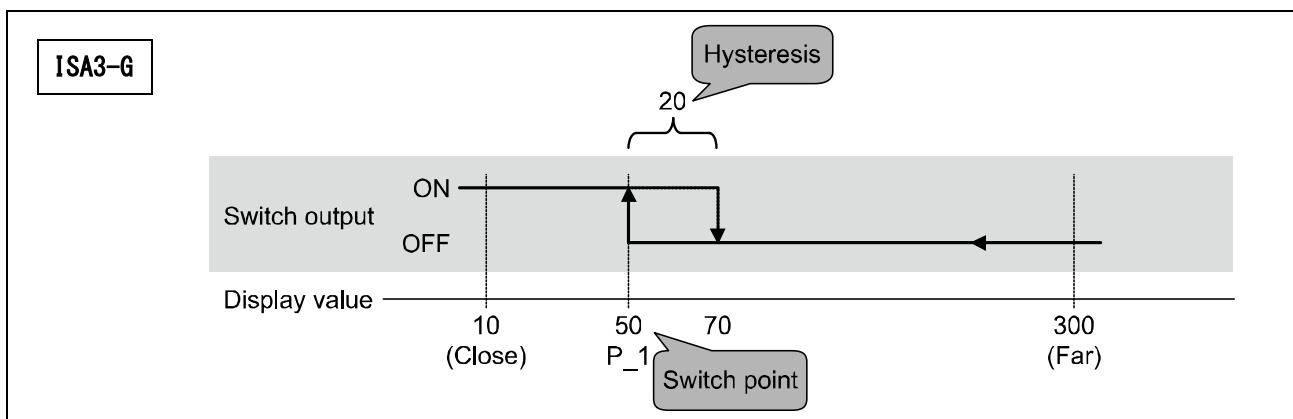
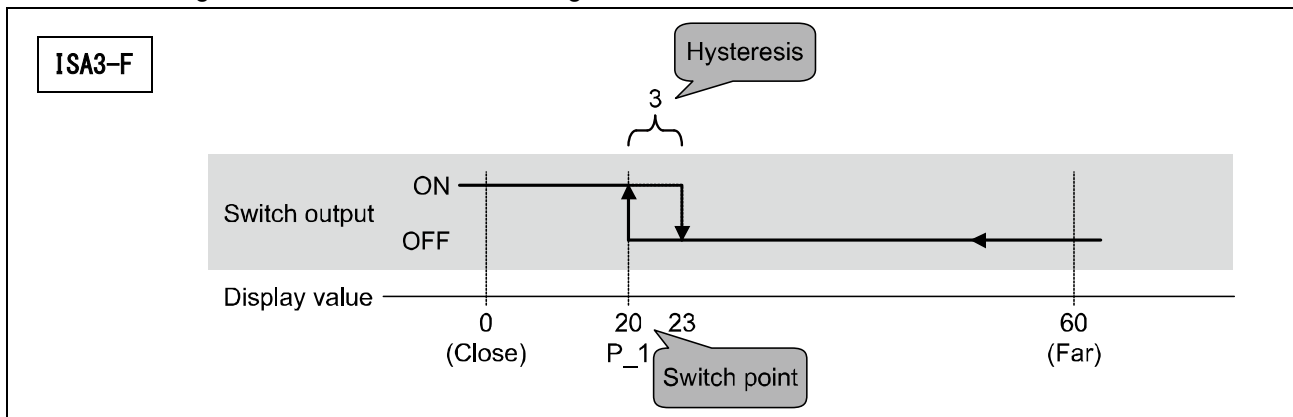

The switch output turns ON when the display value is less than switch point. (Solid line in the chart)

The switch output turns OFF when the display value is greater than the switch point added to the hysteresis value. (Dashed line in the chart)

■ Default settings of OUT2

The default setting is as shown below. It is possible to adjust the pressure setting.
 (Output mode: OUT port window comparator mode, Setting of reverse output: normal output)

Switch output

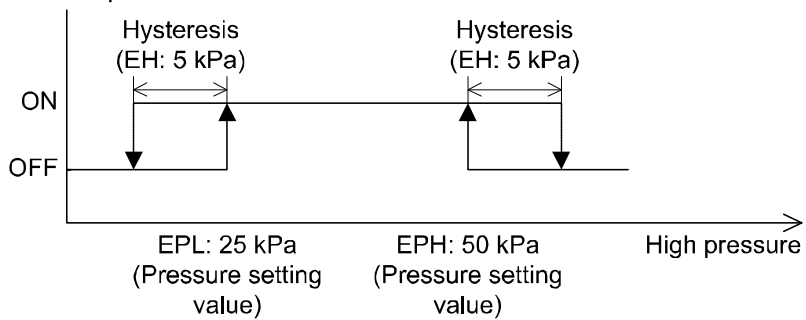

Refer to the following pages for how to change the settings.

■ Preparation before setting

- (1) Supply pressure to the product. (100 to 200 kPa)
- (2) Insert a acceptable clearance gauge between the detection surface and the workpiece.
Alternatively, place a sample workpiece (non-defective workpiece) on the detection nozzle.

■ Setting

- (1) Press the **SET** button while in measurement mode. The display value will be displayed in the main screen and the switch point of OUT1 in the sub screen.
- (2) Press the **▲** or **▼** buttons to adjust the switch point value.
*: Pressing the **▲** and **▼** buttons simultaneously for a minimum of 1 second, then releasing the buttons when the displayed switch point value disappears, will make the switch point the same as the current display value. (Snap shot function)
Then, it is possible to adjust the switch point value by pressing the **▲** or **▼** buttons.

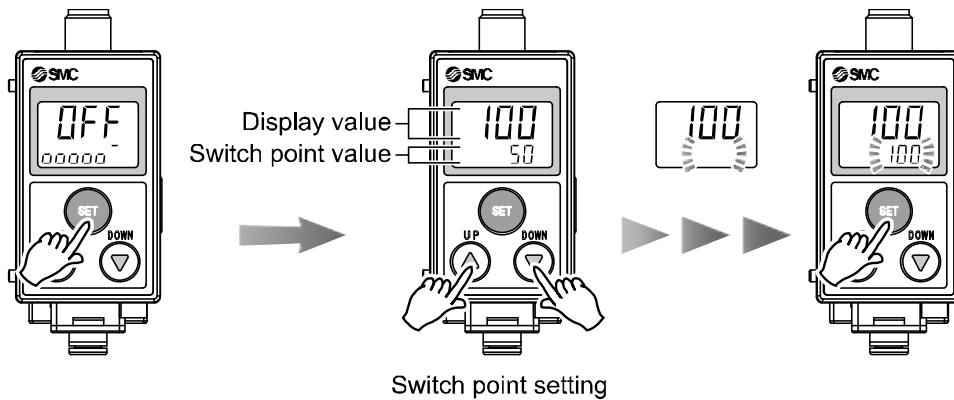

- (3) Press the **SET** button to complete the switch point setting. The product will return to OUT2 setting mode.
- (4) Press the **▲** or **▼** buttons to adjust the set value.

*: Press [F 2] in function selection mode to change the output mode, normal or reverse output and hysteresis settings.
(Refer to page 52)
(Snap shot function) can be used during pressure setting.

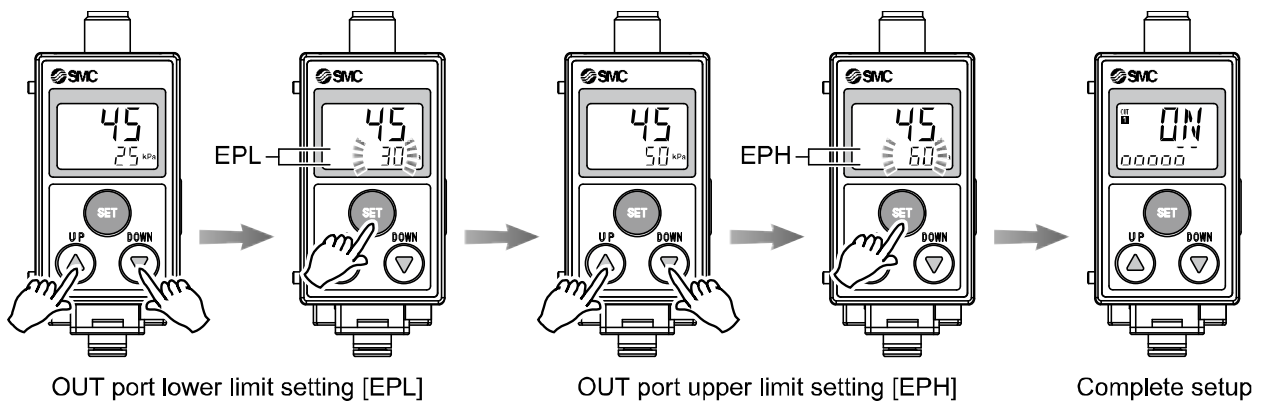

- (5) Press the **SET** button to complete the setting. The product will return to measurement mode.

Function Setting

Function selection mode

In measurement mode, press the **SET** button for 2 seconds or longer to display [F 0].

Select to display the function to be changed, [F□□].

Press the **SET** button for 2 seconds or longer in function selection mode to return to measurement mode.

<Operation>

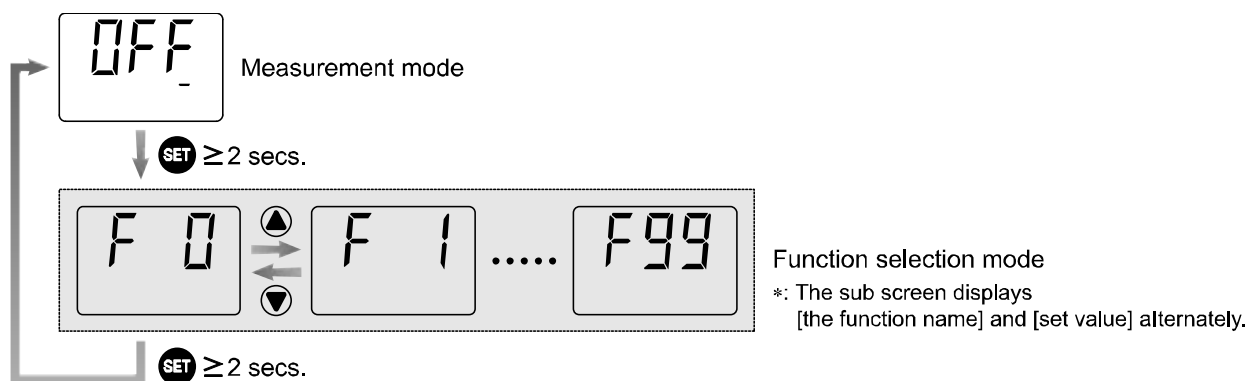

Table of default settings

Refer to the table below for the default settings.

Function number	Function name	Default setting	Page
F 0 (Unit)	Unit selection □	[PA] kPa	Page 49
F 1 (oUt1)	OUT1 setting	Switch point ISA3-F: [20] ISA3-G: [50] ISA3-H: [50]	Page 50
		Hysteresis ISA3-F: [3] ISA3-G: [20] ISA3-H: [20]	
		Display colour [SoG] Green when ON, Orange when OFF	
F 2 (oUt2)	OUT2 setting	Output mode out2: [Ewin] OUT port side pressure detection Window comparator mode	Page 52
		Reversed output 2ot: [2_P] Normal output	
		Pressure setting EPL: [25] kPa EPH: [50] kPa	
		Hysteresis EH: [5] kPa	
		Response time rES: [1000]	
F 6 (FSt)	Display value compensation	[0.0] Compensated value: 0.0	Page 55
F10 (SUB)	Sub screen	[LEVEL] Level meter	Page 56
F80 (dSP)	Display OFF mode	[on] Normal operation mode	Page 57
F81 (Pin)	Security code	[oFF] Security code is not set	Page 58
F90 (ALL)	Setting of all functions	[oFF] Not set all items	Page 59
F98 (tESt)	Forced output	[normAL] Normal output	Page 60
F99 (ini)	Reset to default settings	[oFF] Not return to default settings	Page 61

*: This setting is only available for models with the unit selection function.

○ [F 0] Unit selection for pressure value

Select the units for the pressure value to be indicated on the sub screen.

This setting is only available for models with the unit selection function. Units cannot be selected with the product number "-M".

When models other than the unit selection type are used, "---" will be indicated on the sub screen.

<Operation>

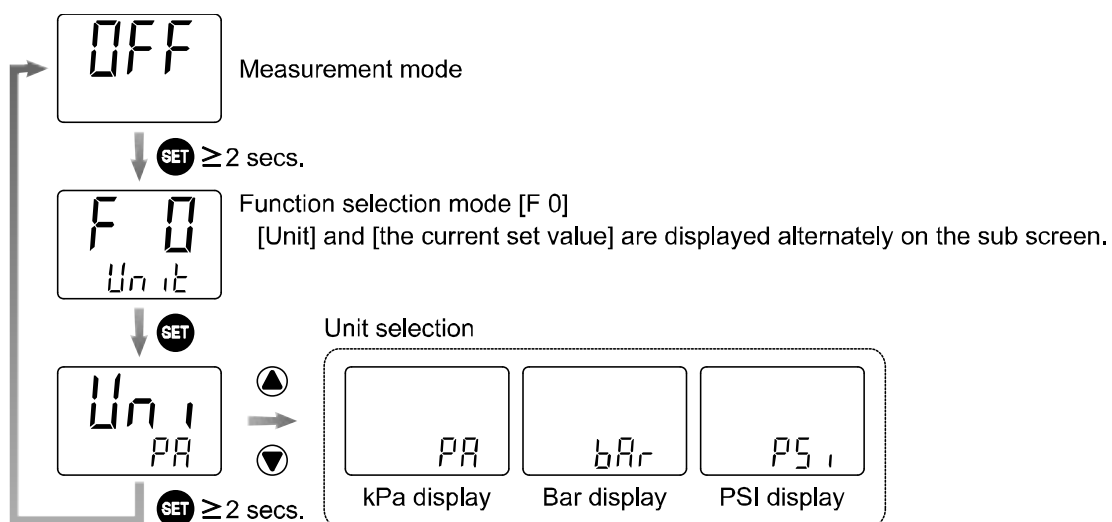

○[F 1]Setting the switch point, hysteresis, display colour (OUT1)

Setting the switch point (P_1), hysteresis (H_1), and display colour.
Refer to the figure below for the default settings.

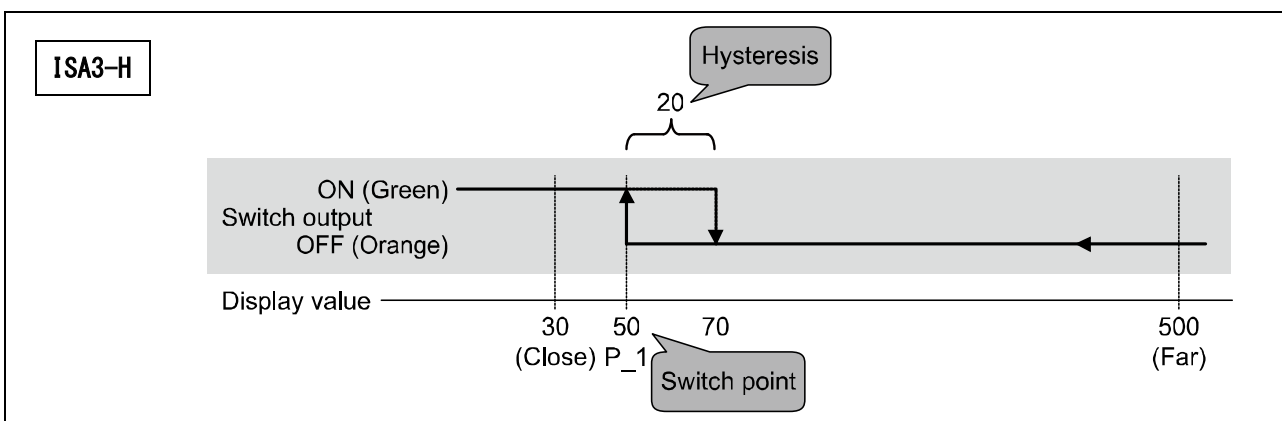
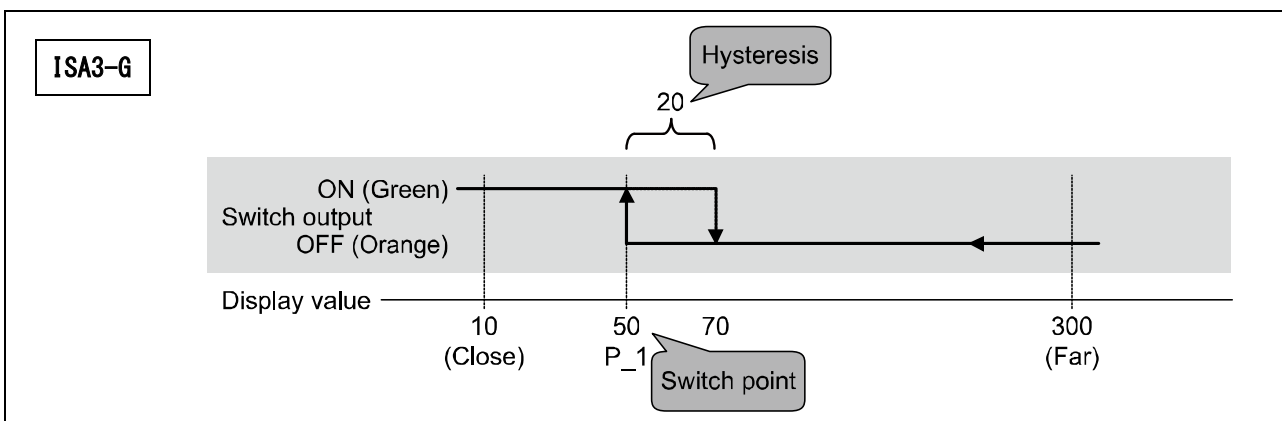
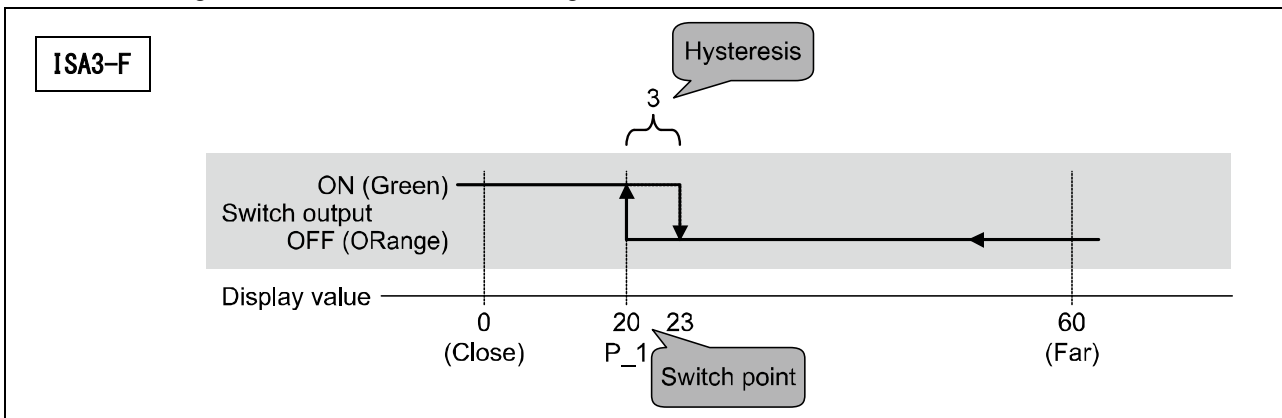

The switch output turns ON when the display value is less than switch point. (Solid line in the chart)
The switch output turns OFF when the display value is greater than the switch point added to the hysteresis value. (Dashed line in the chart)

Refer to the following pages for how to change the settings.

<Operation>

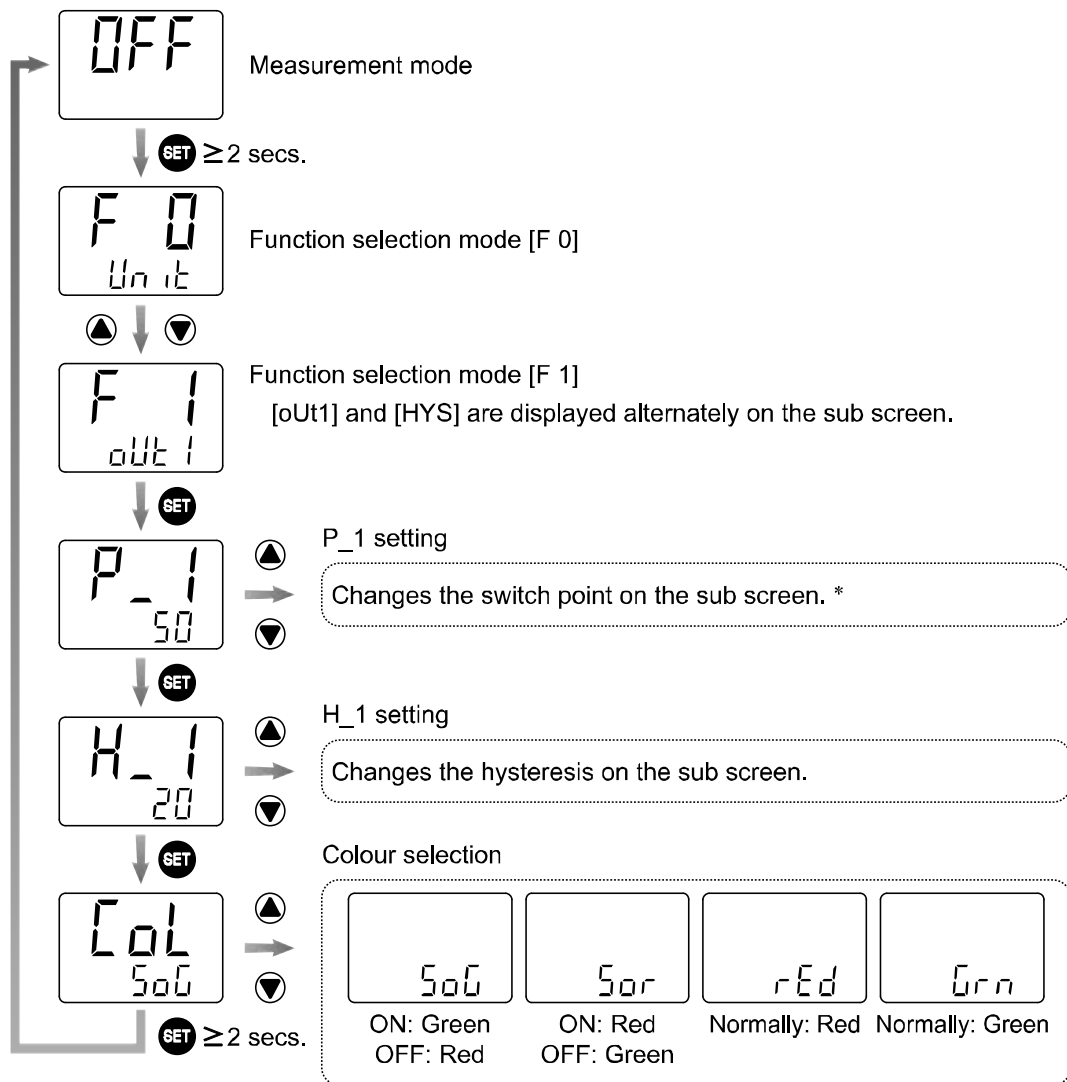

*: The display value on the main screen can be converted to the switch point setting by pressing the ▲ and ▼ buttons simultaneously for 1 second or longer and releasing them (To reduce the setting operation).

○ [F 2] Setting of OUT2

The setting of output OUT2 (pressure detection) can be performed.

Pressure detection on the OUT port or pressure detection or distance detection on the SUP port can be set. Select the pressure detection for either the OUT port or SUP port, pressure set value or switch output of distance detection and hysteresis mode from the list of output modes below.

○ List of output modes

● OUT port pressure detection

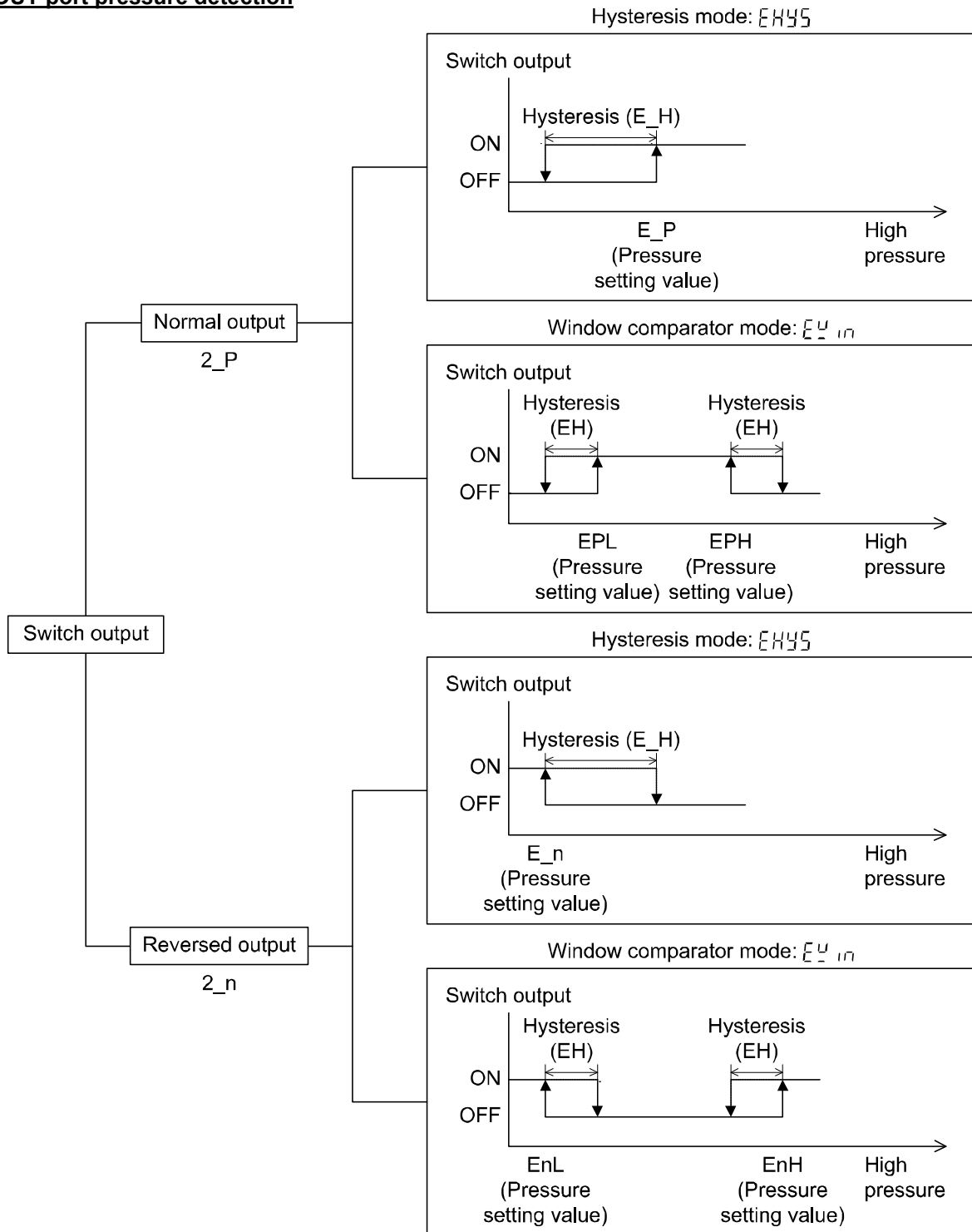

If the set value when the switch output is changed is outside the set pressure range due to switching between normal and reversed output, the hysteresis will automatically be compensated.

•SUP port pressure detection

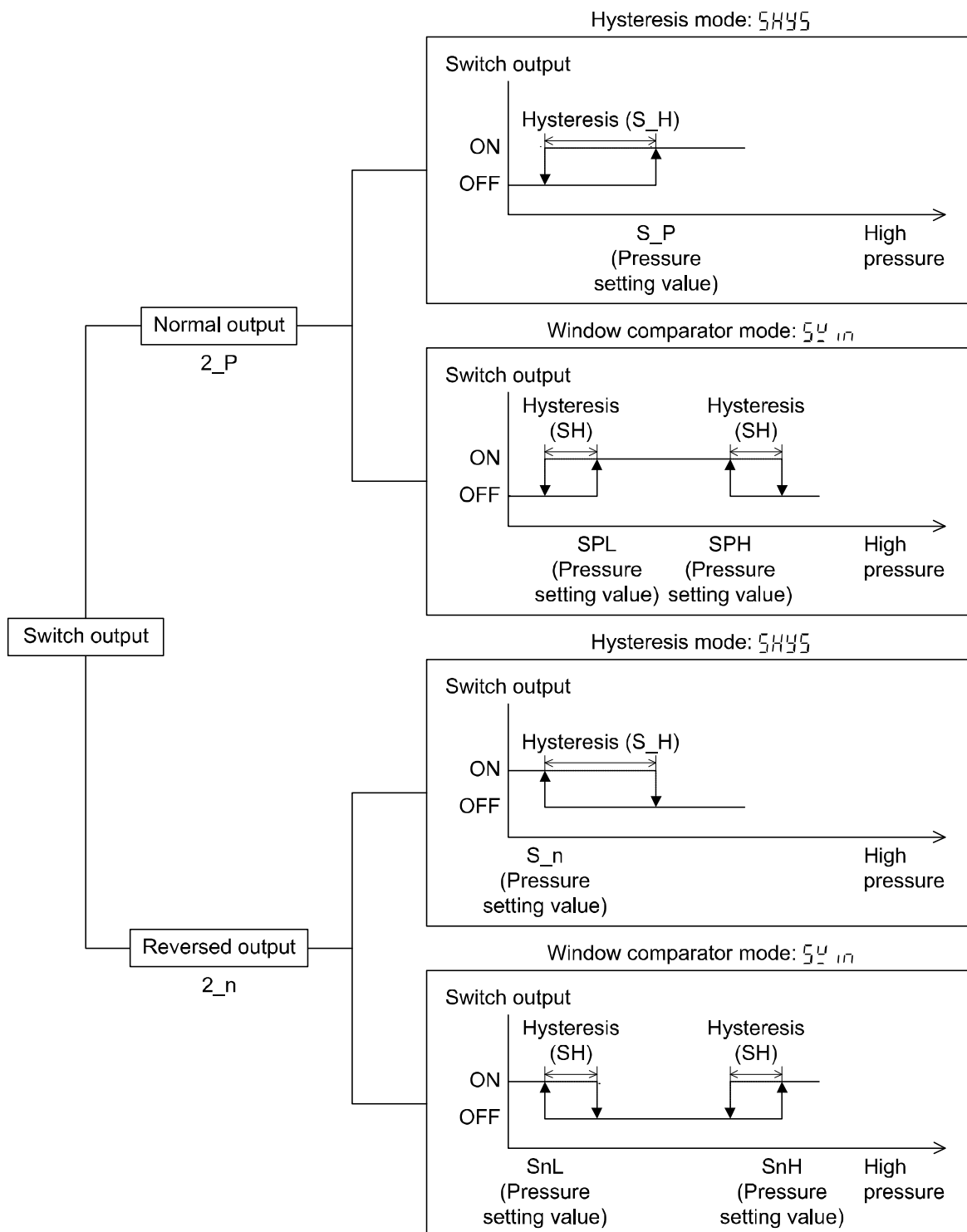

If the set value when the switch output is changed is outside the set pressure range due to switching between normal and reversed output, the hysteresis will automatically be compensated.

•For distance detection

Same as the setting of switch point and hysteresis of OUT1.

<Operation>

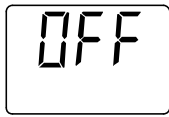

Measurement mode

SET ≥ 2 secs.

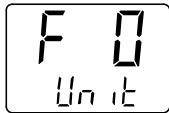

Function selection mode [F 0]

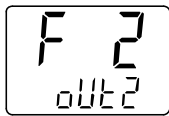

Function selection mode [F 2]
[oUt2] and [current output mode] are displayed alternately on the sub screen.

Select output mode

E_U in

E_{HYS}

S_U in

S_{HYS}

d.i.st

Window comparator mode on the OUT port pressure Hysteresis mode on the OUT port pressure Window comparator mode on the SUP port pressure Hysteresis mode on the OUT port pressure Distance detection mode

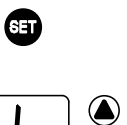
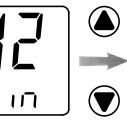

Select normal or reversed output

2_P

2_n

Normal output Reversed output

*: Only for pressure detection setting.
Skip this for distance detection setting.

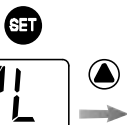

Change the pressure value/switch point and hysteresis on the sub screen. *
*: The Snap shot function can be used during pressure setting (excluding while the hysteresis is being changed.)
The setting and display will be changed depending on the output mode selection.

	OUT port selection				SUP port selection				Distance detection mode
	Window comparator mode		Hysteresis mode		Window comparator mode		Hysteresis mode		
	Normal output	Reversed output	Normal output	Reversed output	Normal output	Reversed output	Normal output	Reversed output	
Change in pressure value	E _{PL}	E _{nL}	E _P	E _n	S _{PL}	S _{nL}	S _P	S _n	P_2
Change in hysteresis	E _H	E _H	E _H	E _H	S _H	S _H	S _H	S _H	H_2

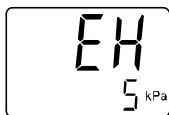
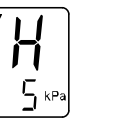

Select response time

1000
1 s

500
500 ms

100
100 ms

20
20 ms

25
2.5 ms

2000
2 s

*: Only for pressure detection setting.
Skip this for distance detection setting.

○ [F 6] Display value compensation

The display value can be corrected within $\pm 20\%$ R.D. of the display value, at the time of shipment.

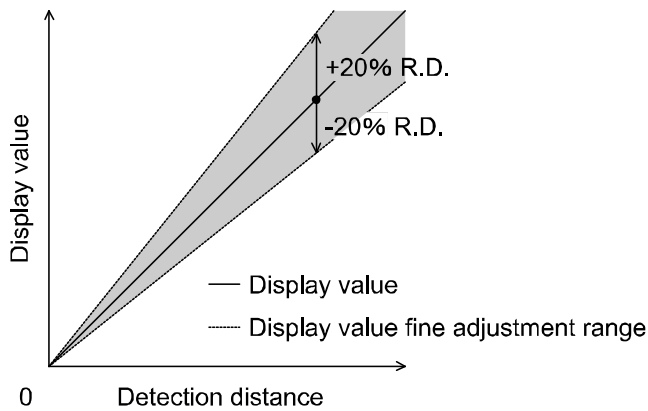

<Operation>

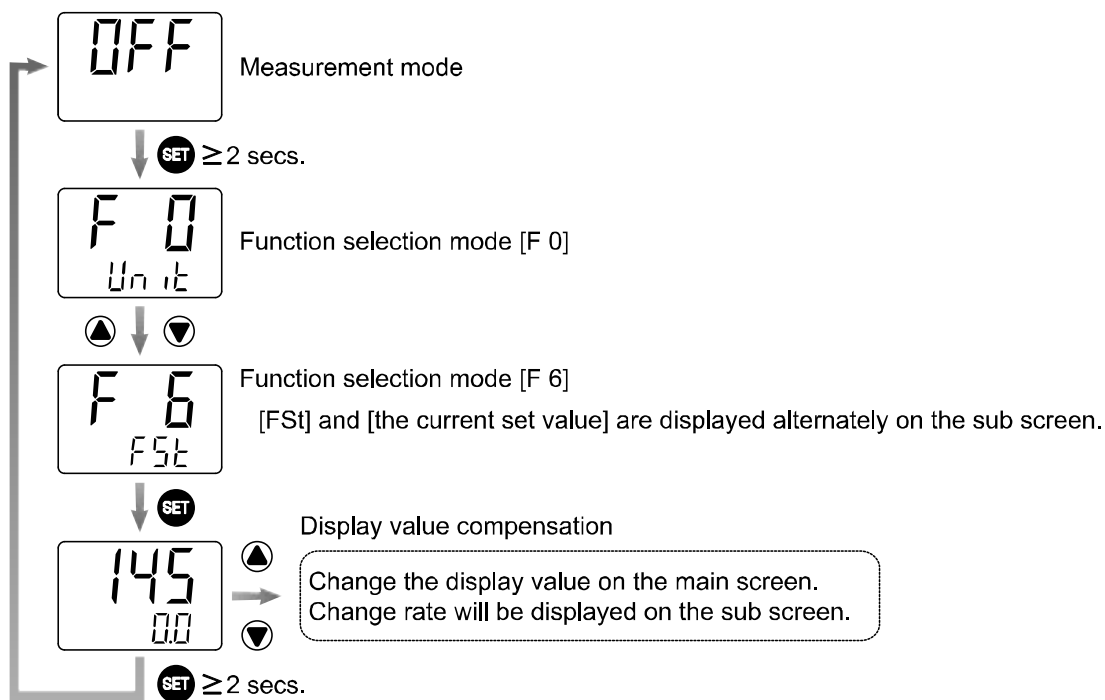

○ [F10] Sub screen setting

The sub screen indication during measurement mode can be selected from the following: Level meter, display value, SUP port pressure, SUP port bottom value, SUP port peak value, OUT port pressure, switch point and display OFF can be selected.

<Operation>

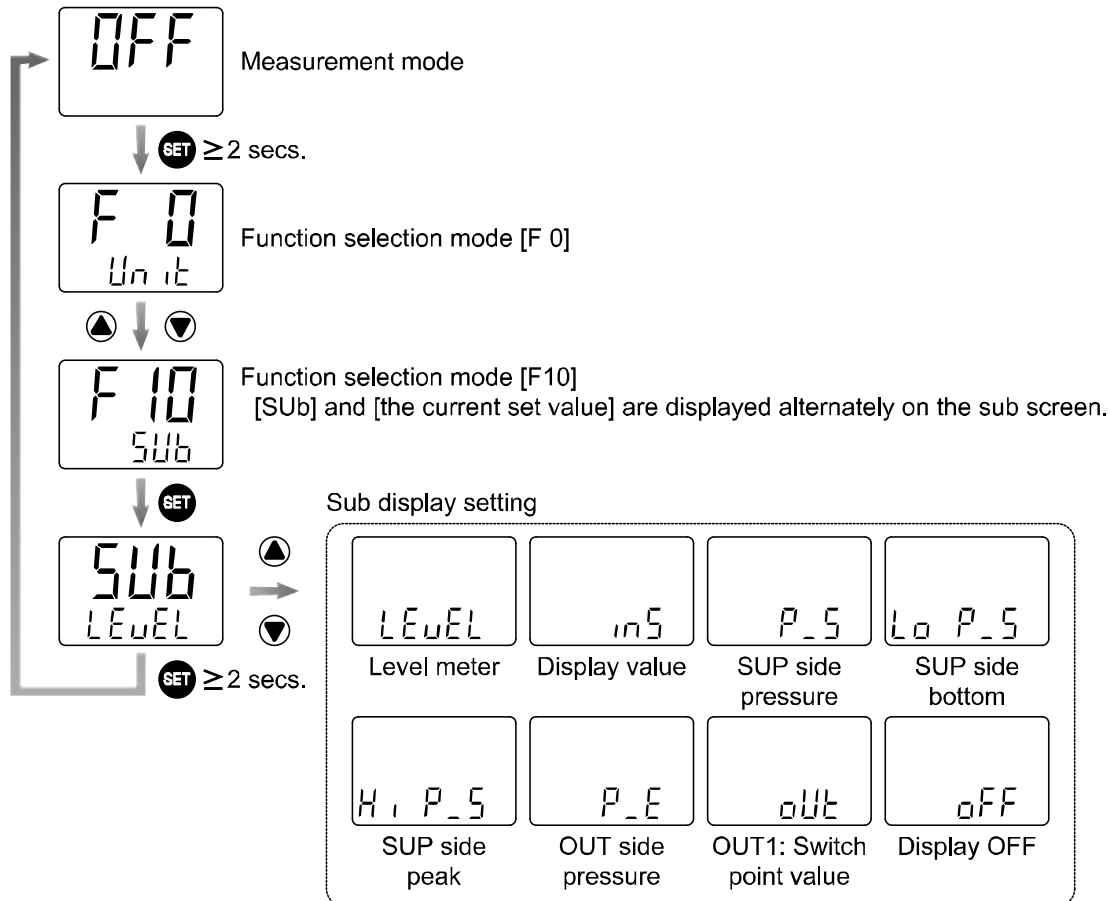

○ **[F80] Display OFF mode**

The display can be turned OFF to reduce power consumption.
 When no buttons have been pressed for 30 seconds, the display will shift to display OFF mode.
 While the display is OFF, the decimal points of the sub screen will flash.
 The default setting is "Display ON" (Normal operation mode).

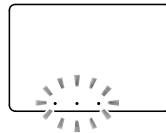

Display OFF mode.

<Operation>

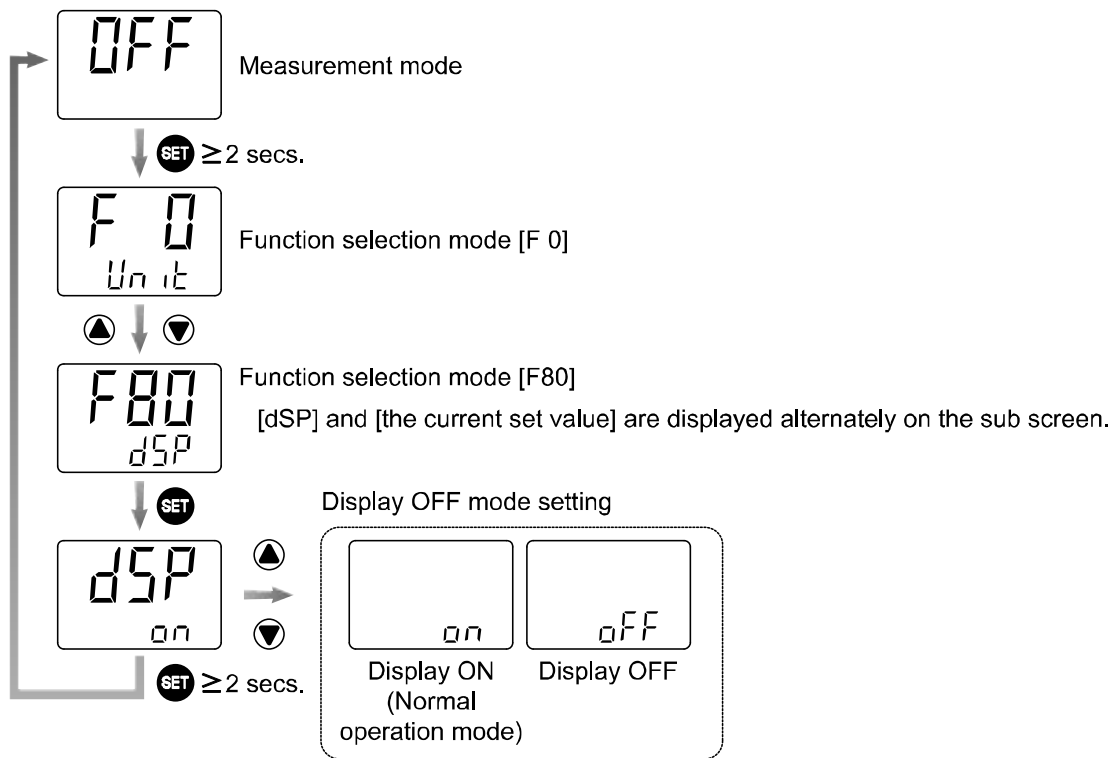

○[F81] Setting the security code for key-lock

A security code can be selected, which must be entered to unlock the keys.
 When the security code has been set, the code entry is required to unlock the keys.
 Refer to page 62 for key-lock and changing of the security code.
 The default setting is “Security code is not set”.

<Operation>

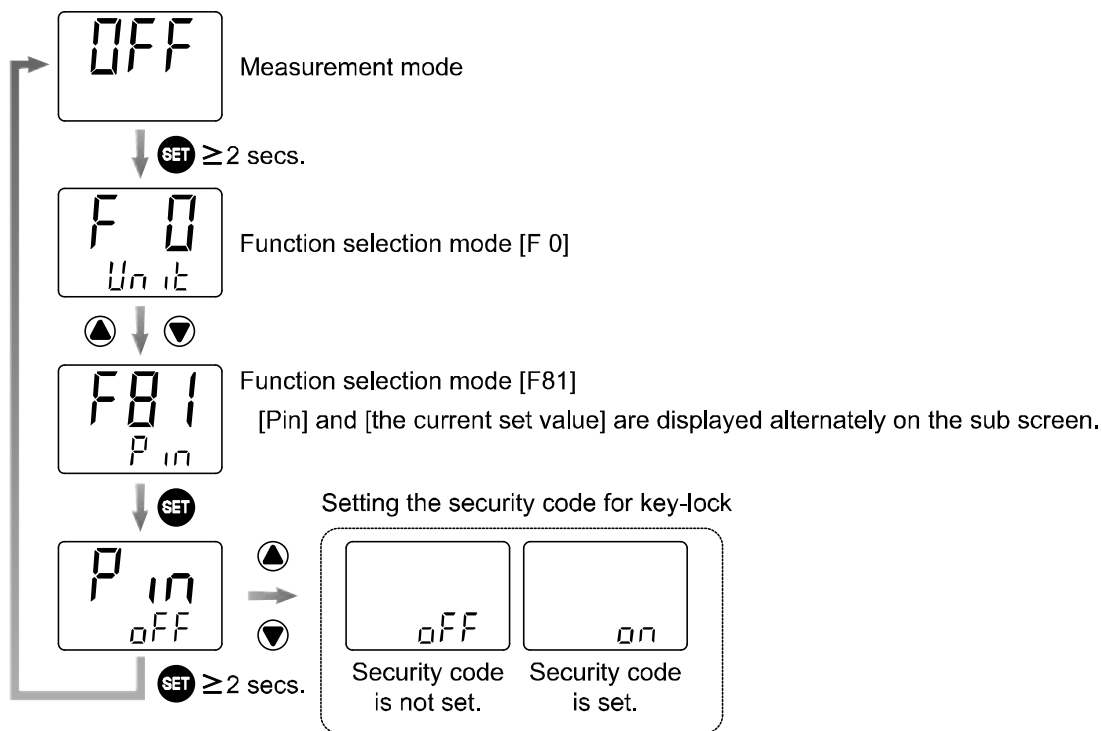

○ [F90] Setting of all functions

The setting of all functions in function selection mode is available.

<Operation>

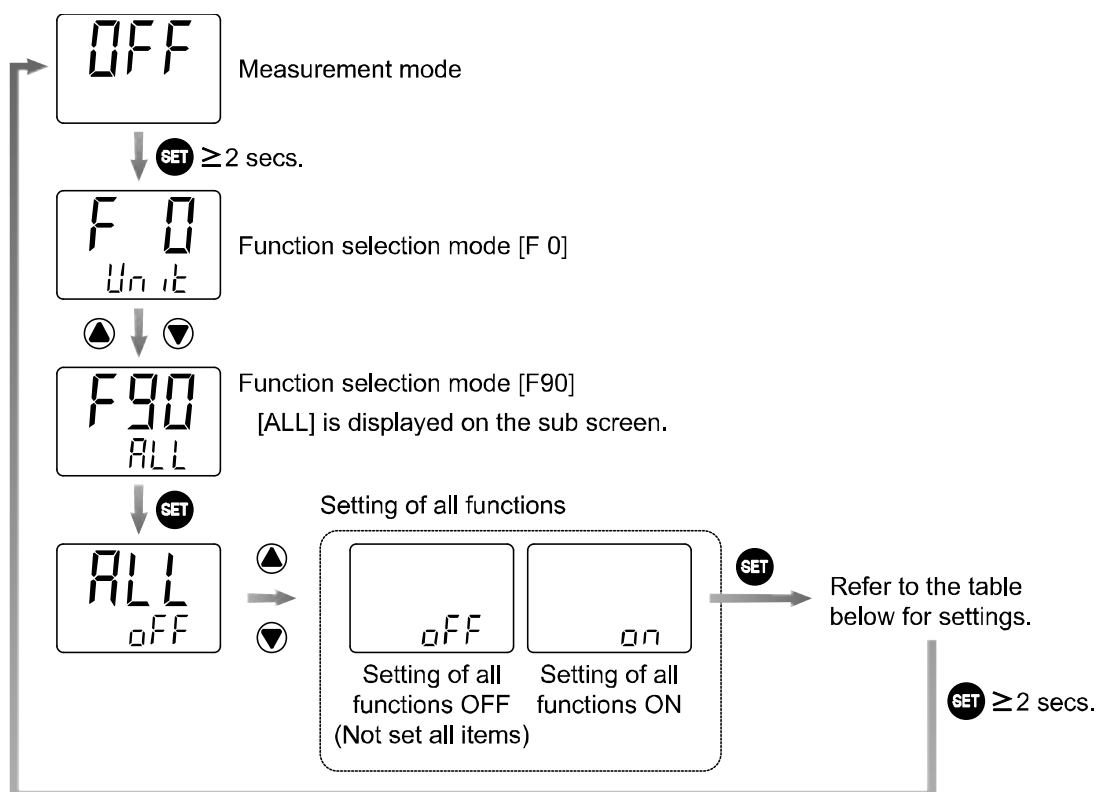

● Order of function settings

Order	Function	Applicable model
1	[Uni] Setting of pressure value units.	This setting is only available for models with the unit selection function.
2	[P_1] Switch point	All models
3	[H_1] Hysteresis	All models
4	[CoL] Setting display colour.	All models
5	[oU2] OUT2 mode setting	All models
6	[2ot] Output mode	For pressure detection mode only
7	[] Pressure value/switch point setting	All models
8	[] OUT2 hysteresis setting	All models
9	[rES] OUT2 response time	For pressure detection mode only
10	[] display value compensation	All models
11	[SUb] Sub screen	All models
12	[dSP] Display OFF mode	All models
13	[P in] Reset to default settings.	All models

○[F98] Forced output

Forced output to test the product and the wiring.

<Operation>

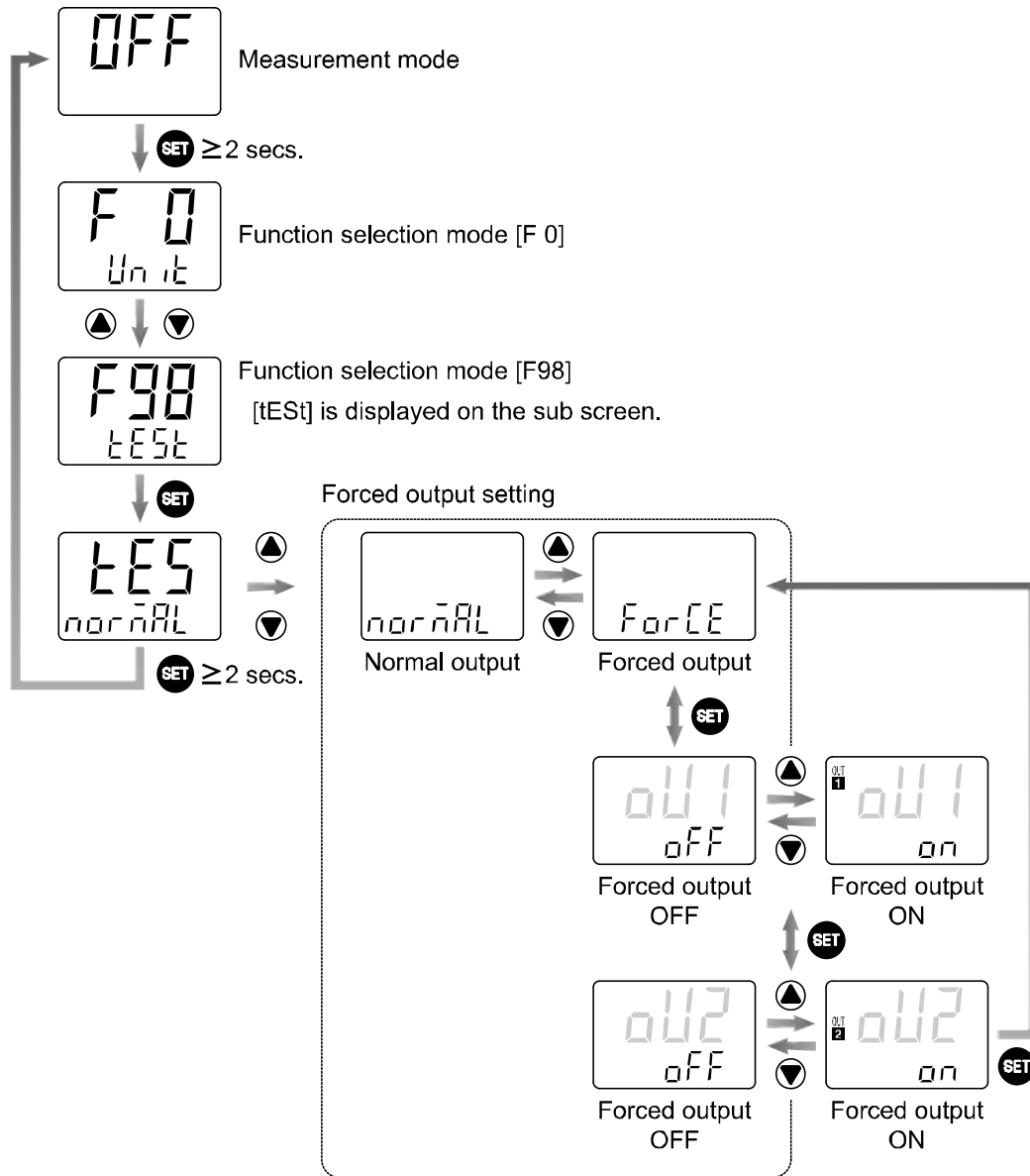

○ [F99] Reset to default settings

The product can be returned to its factory default settings.

<Operation>

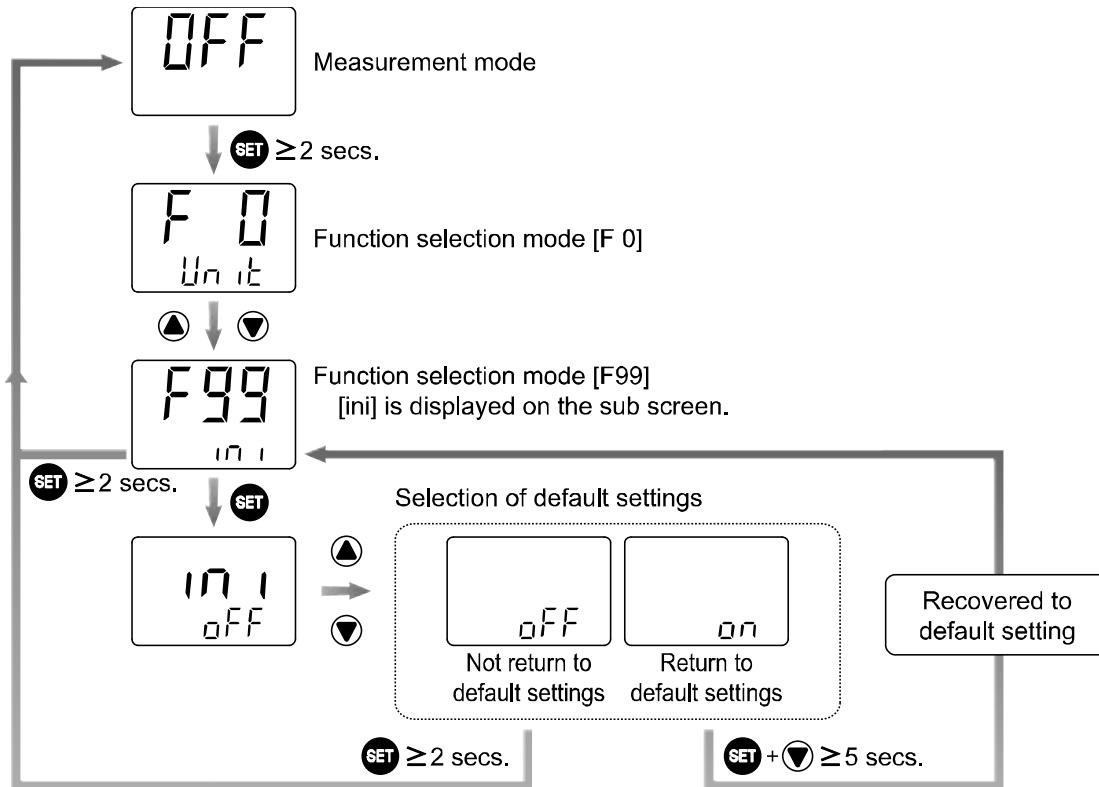

Key lock (Setting security code)

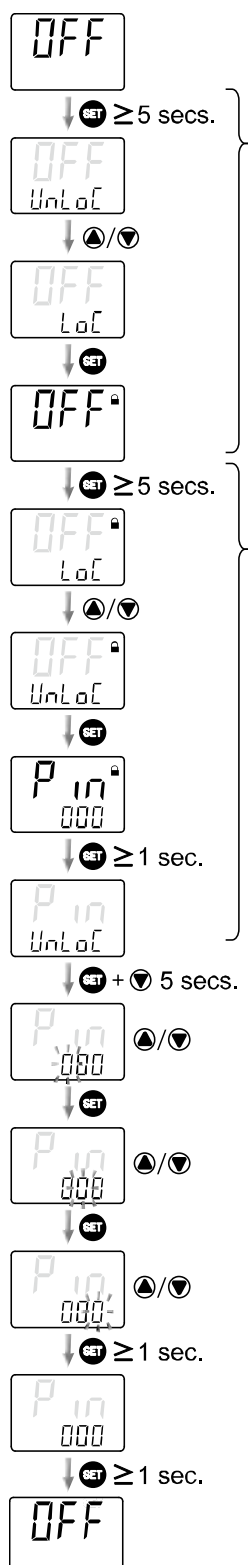

<Operation>

- Select security code [on] in function selection mode [F81]
- Perform key-lock in measurement mode.
- Release the key-lock.
- The security code is requested. The default setting is [000]. Press the **SET** button for 1 second when the security code is [000].
- When the key-lock is released, [UnLoC] will be displayed. A new security code can be set by pressing the **SET** and **▼** buttons simultaneously for 5 seconds or longer.
- Press the **▲** or **▼** button to change the “100” digit. When the required number is determined, press the **SET** button.
- Press the **▲** or **▼** button to change the “10” digit. When the required number is determined, press the **SET** button.
- Press the **▲** or **▼** button to change the “1” digit. When the required number is determined, press the **SET** button.
- The display will stop flashing. Check the new security code. Press the **SET** button for 1 second or longer when the new security code is confirmed.
- Return to measurement mode. The security code setting is complete.

*: If no key operation is performed for 30 seconds during input or change of the security code, the display will return to measurement mode with [LoC] status.

*: If the security code entered is wrong, [FAL] will be indicated on the sub screen. If an incorrect security code is entered 3 times, the display will return to measurement mode with [LoC] status.

Maintenance

Nozzle Cleaning

The OUT port orifice can be removed for cleaning by removing the retaining screw.

Flush inside the orifice with air or wipe off foreign matter with a soft clean cloth. Correct detection may not be possible if the orifice is dirty or scratched.

- (1) Remove the screw (2 pcs.) at the side of the OUT port.
- (2) Remove the OUT port with a flat head screw driver as shown in the figure below. Take care to keep the direction of removal straight.
- (3) Remove the O-ring from the orifice for cleaning. Clean the orifice.

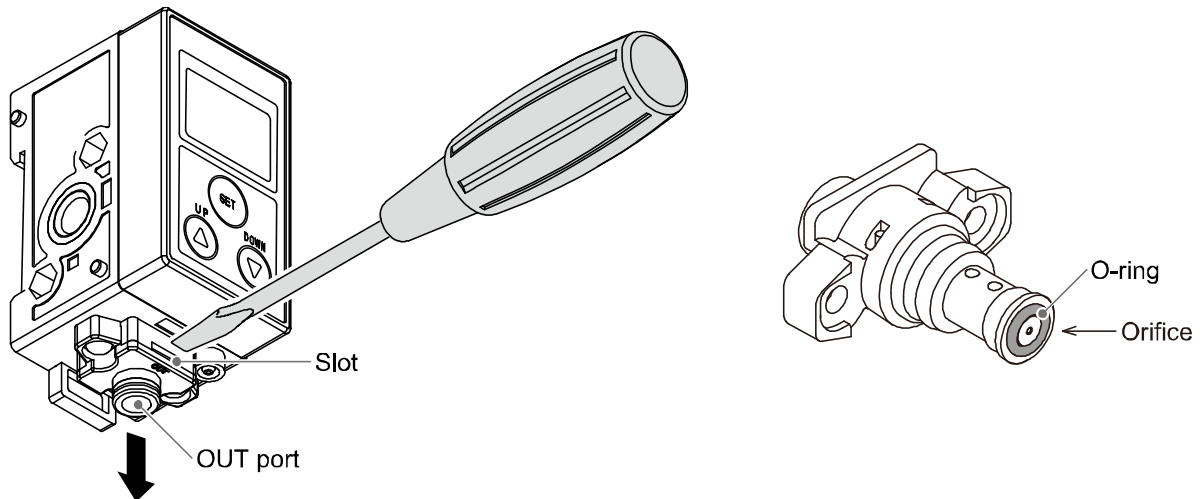

- (4) Place the O-ring back into the orifice.
- (5) Ensure correct orientation of the OUT port, and insert it straight into the body.

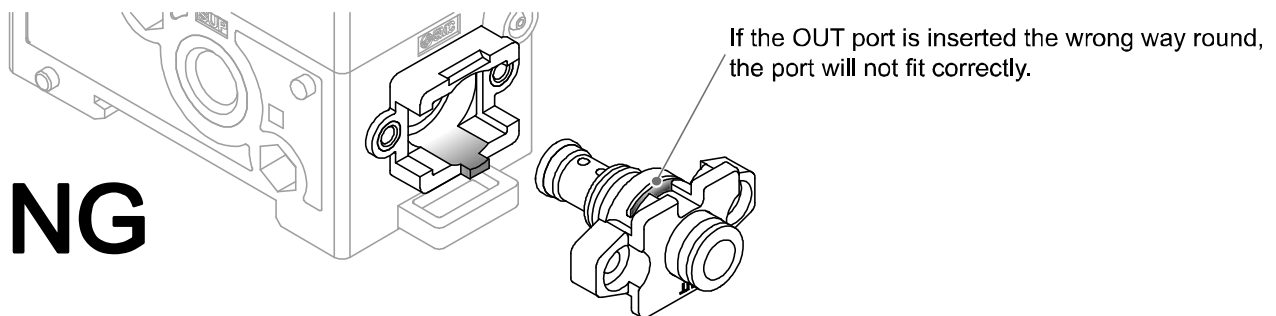
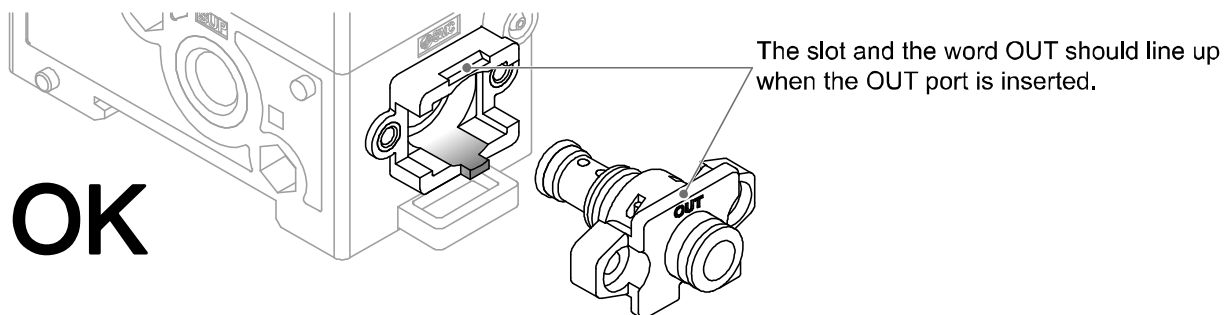

- (6) Tighten the screws on the OUT port side. (Tightening torque: 0.3 N•m).

*: If the orifice is taken out, perform set-up again.

Forgotten the security code

If you have forgotten your security code, please contact SMC directly.

Troubleshooting

If an operation failure of the product occurs, please confirm the cause of the failure from the following table. If a cause applicable to the failure cannot be identified and normal operation can be recovered by replacement with a new product, this indicates that the product itself was faulty. Problems with the product may be due to the operating environment (installation etc). Please consult SMC.

●Cross-reference for troubleshooting

Fault	Possible cause	Countermeasures
Output does not turn ON	Supply pressure error	Supply rated pressure. (100 kPa to 200 kPa)
	Setting is not correct	Perform setting correctly. (Refer to Page 42)
	Air leakage	Connect piping correctly and eliminate any air leakage.
Output stays ON (Does not turn OFF)	Setting is not correct	Perform setting correctly. (Refer to Page 42)
	Clogged piping	Apply pressure lower than the withstand pressure to eliminate the cause of clogging of piping.
The indicator LED operates correctly. Output does not turn ON	Incorrect wiring	Connect wires correctly. (Refer to Page 35)
	Selected product is not correct.	Check if the output specification (NPN / PNP) is correct.
The Gap cannot be detected correctly.	Incorrect supply pressure.	Supply rated pressure. (100 kPa to 200 kPa)
	Nozzle shape is not correct.	Correct the nozzle shape. (Refer to Page 28)
	Multiple detection nozzles are used.	Do not use multiple detection nozzles with one product. If multiple nozzles are to be used, please test them on the actual equipment. It is necessary for the user to verify correct operation.
	Equipment or fittings causing leakage or resistance are used.	Do not use equipment or fittings that may leak or obstruct the air flow between the product and the detection nozzle.
	The product is not higher than the detection nozzle.	The product should be positioned higher than the detection nozzle.

If the troubleshooting of ISA3 does not solve the problems, it is possible that the regulator or 2 port solenoid valve has problems. Take appropriate corrective action by referring the troubleshooting for the regulator and 2 port solenoid valve.

■ Error indication

Main screen	Error Name	Description	Measures
- - -	Supply pressure error	Displayed when supply pressure is less than 80 kPa or more than 220 kPa. Measurement is not possible.	Supply rated pressure. (100 kPa to 200 kPa) The product will return to measurement mode automatically.
- - -	Display value outside of the displayable range (Switch point setting mode)	The workpiece is outside the displayable range.	Move the workpiece closer to the detection nozzle.
Er 1	OUT1 over current error	The switch output (OUT1) load current has exceeded 80 mA.	Turn the power OFF and remove the cause of the over current. Then turn the power ON again.
Er 2	OUT2 over current error	The switch output (OUT2) load current has exceeded 80 mA.	Turn the power OFF and remove the cause of the over current. Then turn the power ON again.
Er 3	Zero clear error	Zero clear was performed in non-atmospheric pressure (Pressure outside of ± 14 kPa was supplied present.)	Perform zero clear at atmospheric pressure.
Er 0	System error	An internal data error has occurred.	Turn the power OFF and turn it ON again.
Er 4			
Er 9			
Sub screen	Error Name	Description	Measures
HHH	Supply pressure error (When pressure is displayed on the sub screen)	Pressure exceeding 220 kPa is supplied.	Keep the supply pressure within the display range of -20 kPa to 220 kPa.
LLL		Vacuum pressure (-20 kPa or less) is supplied.	

■ Relationship between supply pressure and display

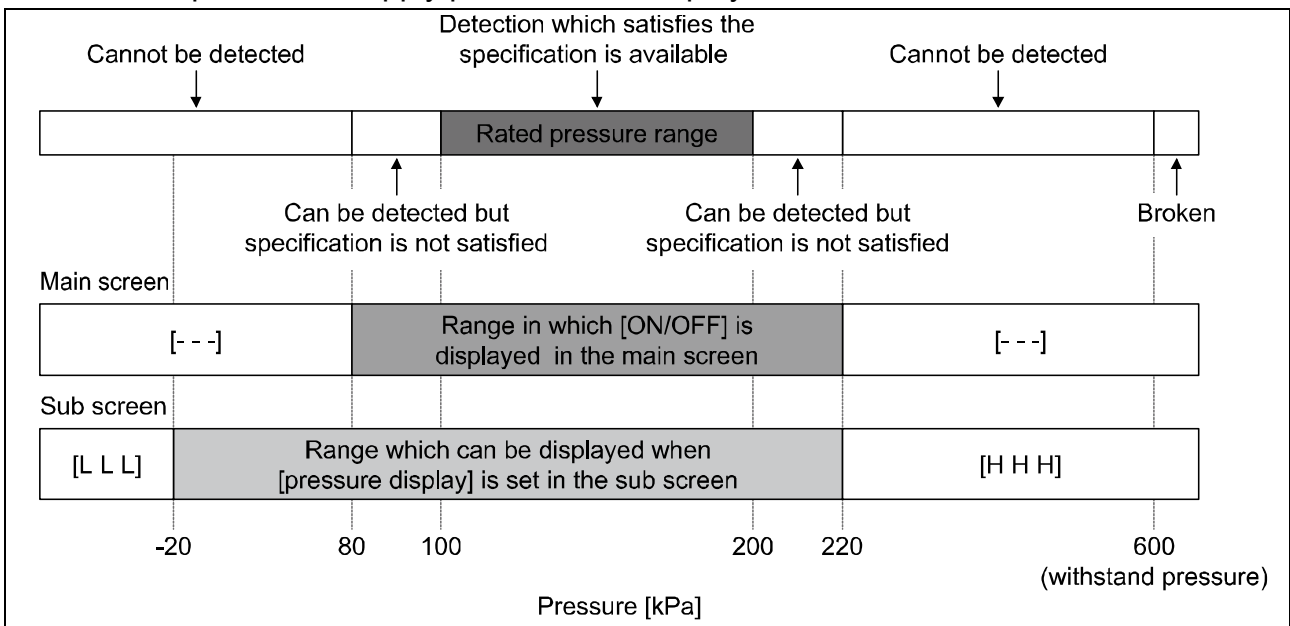

Revision history

A: Contents are added.[March 2018]
B: Contents revised in several places. [June 2018]
C: Contents revised in several places.
[September 2019]
D: Contents revised in several places.
[October 2021]
E: Contents revised in several places.
[June 2022]

SMC Corporation

4-14-1, Sotokanda, Chiyoda-ku, Tokyo 101-0021 JAPAN

Tel: + 81 3 5207 8249 Fax: +81 3 5298 5362

URL <https://www.smcworld.com>

Note: Specifications are subject to change without prior notice and any obligation on the part of the manufacturer.
© 2015-2022 SMC Corporation All Rights Reserved

