



Operation Manual

Solenoid Valve

PRODUCT NAME

SJ1000/2000/3000 Series

MODEL/ Series

SMC Corporation

Contents

Contents	1
Safety Instructions	2,3
Design / Selection	4 to 6
Mounting	6
Piping	6
Wiring	7
Lubrication	7
Air Supply	7
Operating Environment	8
Maintenance	8
UL approved	8
Specific Product Precautions	9 to 15
Valve Construction	16 to 23
Trouble shooting	24,25



Safety Instructions

These safety instructions are intended to prevent hazardous situations and/or equipment damage. These instructions indicate the level of potential hazard with the labels of "Caution," "Warning" or "Danger." They are all important notes for safety and must be followed in addition to International Standards (ISO/IEC)*1), and other safety regulations.

*1) ISO 4414: Pneumatic fluid power -- General rules relating to systems.

ISO 4413: Hydraulic fluid power -- General rules relating to systems.

IEC 60204-1: Safety of machinery -- Electrical equipment of machines .(Part 1: General requirements)

ISO 10218: Manipulating industrial robots -Safety.

etc.



Caution

Caution indicates a hazard with a low level of risk which, if not avoided, could result in minor or moderate injury.



Warning

Warning indicates a hazard with a medium level of risk which, if not avoided, could result in death or serious injury.



Danger

Danger indicates a hazard with a high level of risk which, if not avoided, will result in death or serious injury.

Warning

1. The compatibility of the product is the responsibility of the person who designs the equipment or decides its specifications.

Since the product specified here is used under various operating conditions, its compatibility with specific equipment must be decided by the person who designs the equipment or decides its specifications based on necessary analysis and test results.

The expected performance and safety assurance of the equipment will be the responsibility of the person who has determined its compatibility with the product.

This person should also continuously review all specifications of the product referring to its latest catalog information, with a view to giving due consideration to any possibility of equipment failure when configuring the equipment.

2. Only personnel with appropriate training should operate machinery and equipment.

The product specified here may become unsafe if handled incorrectly.

The assembly, operation and maintenance of machines or equipment including our products must be performed by an operator who is appropriately trained and experienced.

3. Do not service or attempt to remove product and machinery/equipment until safety is confirmed.

1. The inspection and maintenance of machinery/equipment should only be performed after measures to prevent falling or runaway of the driven objects have been confirmed.

2. When the product is to be removed, confirm that the safety measures as mentioned above are implemented and the power from any appropriate source is cut, and read and understand the specific product precautions of all relevant products carefully.

3. Before machinery/equipment is restarted, take measures to prevent unexpected operation and malfunction.

4. Contact SMC beforehand and take special consideration of safety measures if the product is to be used in any of the following conditions.

1. Conditions and environments outside of the given specifications, or use outdoors or in a place exposed to direct sunlight.

2. Installation on equipment in conjunction with atomic energy, railways, air navigation, space, shipping, vehicles, military, medical treatment, combustion and recreation, or equipment in contact with food and beverages, emergency stop circuits, clutch and brake circuits in press applications, safety equipment or other applications unsuitable for the standard specifications described in the product catalog.

3. An application which could have negative effects on people, property, or animals requiring special safety analysis.

4. Use in an interlock circuit, which requires the provision of double interlock for possible failure by using a mechanical protective function, and periodical checks to confirm proper operation.



Safety Instructions

Caution

The product is provided for use in manufacturing industries.

The product herein described is basically provided for peaceful use in manufacturing industries.

If considering using the product in other industries, consult SMC beforehand and exchange specifications or a contract if necessary.

If anything is unclear, contact your nearest sales branch.

Limited warranty and Disclaimer/Compliance Requirements

The product used is subject to the following "Limited warranty and Disclaimer" and "Compliance Requirements".

Read and accept them before using the product.

Limited warranty and Disclaimer

1. The warranty period of the product is 1 year in service or 1.5 years after the product is delivered, whichever is first. *2)

Also, the product may have specified durability, running distance or replacement parts. Please consult your nearest sales branch.

2. For any failure or damage reported within the warranty period which is clearly our responsibility, a replacement product or necessary parts will be provided.

This limited warranty applies only to our product independently, and not to any other damage incurred due to the failure of the product.

3. Prior to using SMC products, please read and understand the warranty terms and disclaimers noted in the specified catalog for the particular products.

*2) Vacuum pads are excluded from this 1 year warranty.

A vacuum pad is a consumable part, so it is warranted for a year after it is delivered.

Also, even within the warranty period, the wear of a product due to the use of the vacuum pad or failure due to the deterioration of rubber material are not covered by the limited warranty.

Compliance Requirements

1. The use of SMC products with production equipment for the manufacture of weapons of mass destruction (WMD) or any other weapon is strictly prohibited.

2. The exports of SMC products or technology from one country to another are governed by the relevant security laws and regulation of the countries involved in the transaction. Prior to the shipment of a SMC product to another country, assure that all local rules governing that export are known and followed.

Caution

SMC products are not intended for use as instruments for legal metrology.

Measurement instruments that SMC manufactures or sells have not been qualified by type approval tests relevant to the metrology (measurement) laws of each country.

Therefore, SMC products cannot be used for business or certification ordained by the metrology (measurement) laws of each country.



Precautions for 4 Port Solenoid Valve 1

Be sure to read before handling. Refer to main text for detailed precautions on every series.

Design / Selection

Warning

1. Confirm the specifications

Products represented in this instruction manual are designed only for use in compressed air systems (including vacuum).

Do not operate at pressures or temperatures, etc., beyond the range of specifications, as this can cause damage or malfunction.

We do not guarantee against any damage if the product is used outside of the specification range.

2. Actuator drive

When an actuator, such as a cylinder, is to be driven using a valve, take appropriate measures (such as the installation of a cover or the restricting of access to the product) to prevent potential danger caused by actuator operation.

3. Intermediate stops

For 3-position closed center, it is difficult to make a piston stop at the required position accurately due to the compressibility of air.

Furthermore, since valves and cylinders are not guaranteed for zero air leakage, it may not be possible to hold a stopped position for an extended period of time. Please contact SMC if it is necessary to hold a stopped position for an extended period of time.

4. Effect of back pressure when using a manifold.

When the air operated valve or single acting cylinder is operated, they may malfunction due to the exhaustion of other actuator. If back pressure is possible to be present, use the valve with back pressure prevention valve, or use air SUP./EXH. block assembly and EXH. block disk to divide air exhaustion.

5. Holding pressure (including vacuum).

Since the valve are subject to air leakage, they cannot be used for applications such as holding pressure (including vacuum) in a pressure vessel.

6. Not suitable for use as an emergency shut-off valve, etc.

The valves listed in this instruction manual are not designed for safety applications such as an emergency shutoff valve. If the valves are used for the mentioned applications, additional safety measures should be adopted.

7. Release of residual pressure

For maintenance and inspection purposes install a system for releasing residual pressure. Especially in the case of 3-position closed center valve, ensure that the residual pressure between the valve and the cylinder is released.

8. Operation for vacuum

When a valve is used for switching a vacuum, take measures to install a suction filter or similar to prevent external dust or other foreign matter from entering inside the valve.

In addition, at the time of vacuum adsorption, be sure to supply a constant supply of vacuum. Failure to do so may result in foreign matter sticking to the adsorption pad or air leakage, causing the workpiece to drop.

9. Regarding a vacuum switch valves and vacuum release valves

If a non-vacuum valve is installed in the middle of a piping system that contains a vacuum, the vacuum condition will not be maintained. Use a valve designed for use under vacuum conditions.

10. Double solenoid type

When using the double solenoid type for the first time, actuators may travel in an unexpected direction depending on the switching position of the valve.

Implement measures to prevent any danger from occurring when operating the actuator.

11. Ventilation

Provide ventilation when using a valve in a confined area, such as in a closed control panel. For example, install a ventilation opening, etc. in order to prevent pressure from increasing inside of the confined area and to release the heat generated by the valve.

12. Extended periods of continuous energization

- If a valve will be continuously energized for an extended period of time, the temperature of the valve will increase due to the heat generated by the coil. This will likely adversely affect the performance of the solenoid valve and any nearby peripheral equipment. Therefore, when it is continuously energized or the energized period per day is longer than the de-energized period, use the valve with a power saving circuit. In addition, it is possible to shorten the energized time by using a valve with an N.O. (normally open) specification.
- For applications such as mounting a valve in a control panel, take the measure to keep the temperature not to exceed valve specification. Please mind it especially in case energizing more than 3 adjacent stations in the same manifold for an extended period of time or energizing both A and B coil of dual 3 port valve for an extended period of time.

13. Do not disassemble the product of make any modifications, including additional machining.

Doing so may cause human injury and/or an accident.

14. Resumption after a long period of holding time

When resuming operation after a long period of holding time, there are cases in which, regardless of whether the product is in an ON or OFF state, there is a delay in the initial response time due to adhesion. Conducting several cycles of running-in operation will solve this problem. Please consider implementing this before resumption.



Precautions for 4 Port Solenoid Valve 2

Be sure to read before handling. Refer to main text for detailed precautions on every series.

Design / Selection

Caution

1. Precautions for 2-position double solenoid valves

If a double solenoid valve is operated with momentary energization, it should be energized for at least 0.1 second. However, depending on the piping conditions, the cylinder may malfunction even when the double solenoid valve is energized for 0.1 seconds or longer. In this case, energize the double solenoid valve until the cylinder is exhausted completely.

2. Leakage voltage

Take note that the leakage voltage will increase when a resistor is used in parallel with switching element or a C-R circuit (surge voltage suppressor) is used for protecting a switching device because of the passing leakage voltage through the C-R circuit.

The suppressor residual leakage voltage should be as 3% or less of the rated voltage.

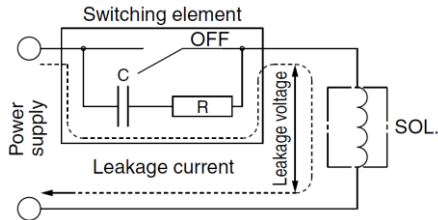

3. Surge voltage suppressor

1) The surge voltage suppressor built into the valve is intended to protect the output contacts so that the surge generated inside valve does not adversely affect the output contacts. Therefore, if an overvoltage or overcurrent is received from an external peripheral device, the surge voltage protection element inside the valve is overloaded, causing the element to break. In the worst case, the breakage causes the electric circuit to enter short-circuit status. If energizing continues while in this state, a large current flows. This may cause secondary damage to the output circuit, external peripheral device, or valve, and may also cause a fire. So, take appropriate protective measures, such as the installation of an overcurrent protection circuit in the power supply or a drive circuit to maintain a sufficient level of safety.

2) If a surge protection circuit contains nonstandard diodes, such as Zener diodes or varistor, a residual voltage that is in proportion to the protective circuit and the rated voltage will remain. Therefore, take into consideration the surge voltage protection of the controller. In the case of diodes, the residual voltage is approximately 1V.

4. Surge voltage intrusion

With non-polar type solenoid valves, at times of sudden interruption of the loading power supply, such as emergency shutdown, surge voltage intrusion may be generated from loading equipment with a large capacity (power consumption), and a solenoid valve in a de-energized state may switch over (see Figure 1). When installing a breaker circuit for the loading power supply, consider using a solenoid valve with polarity (with polarity protection diode), or install a surge absorption diode between the loading equipment COM line and the output equipment COM line (see Figure 2).

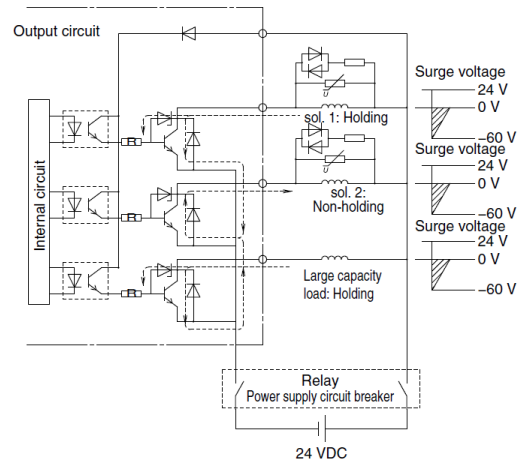

Figure 1. Surge intrusion circuit example (NPN outlet example)

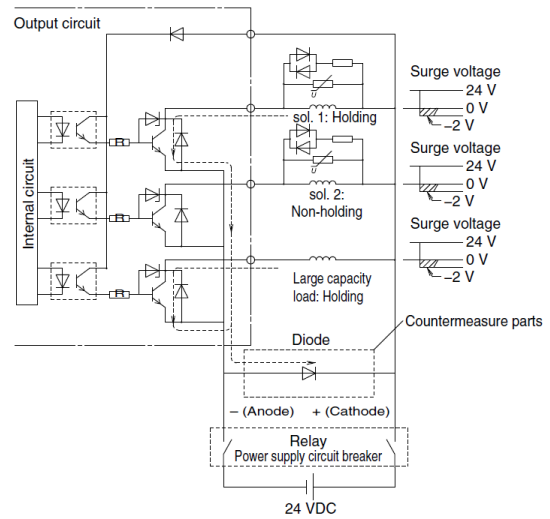

Figure 2. Surge intrusion countermeasure example (NPN outlet example)

5. Operation in low temperature conditions

It is possible to operate a valve in extreme temperatures, as low as -10°C. Take appropriate measures to avoid the freezing of drainage, moisture, etc., in low temperatures.



Precautions for 4 Port Solenoid Valve 3

Be sure to read before handling. Refer to main text for detailed precautions on every series.

Design / Selection

⚠ Caution

6. Operation for air blowing

When using a solenoid valve for air blowing, use an external pilot type. Use caution because the pressure drop caused by the air blowing can have an effect on the internal pilot type valve when internal pilot type valves and external pilot type valves are used on the same manifold.

Additionally, when compressed air within the pressure range of the established specifications is supplied to the external pilot type valve's port, and a double solenoid valve is used for air blowing, the solenoids should be energized when air is being blown.

7. Mounting orientation

Mounting orientation is free.

8. Initial lubrication of main valve

The initial lubricant (Grease) has already been applied to the main valve.

Please consult with SMC, as there are some standard valve products that use fluorine grease for food processing equipment (NSF H-1).

9. For the pilot EXH. (PE) port

If the solenoid valve and the manifold's pilot EXH (PE) port is restricted extremely or blocked, abnormal operation of the solenoid valve may occur.

Mounting

⚠ Warning

1. Operation manual

Install the products and operate them only after reading the operation manual carefully and understanding its contents. Also, keep the manual where it can be referred to as necessary.

2. Ensure sufficient space for maintenance activities.

When installing the products, allow access for maintenance and inspection.

3. Tighten threads with the proper tightening torque.

When installing the products, follow the listed torque specifications.

4. If air leakage increases or equipment does not operated properly, stop operation.

Check mounting conditions when air and power supplies are connected. Initial function and leakage tests should be performed after installation.

5. Painting and coating

Warnings or specifications printed or affixed to the product should not be erased, removed or covered up. Please consult with SMC before applying paint to resinous parts, as this may have an adverse effect due to the solvent in the paint.

Piping

⚠ Caution

1. Refer to the Fittings and Tubing Precautions for handling one-touch fittings.

2. Preparation before piping

Before piping is connected, it should be thoroughly blown out with air (flushing) or washed to remove chips, cutting oil, and other debris from inside the pipe.

3. Winding of sealant tape

When screwing piping or fittings into ports, ensure that chips from the pipe threads or sealing material do not enter the piping.

Also, if sealant tape is used, leave 1 thread ridge exposed at the end of the threads.

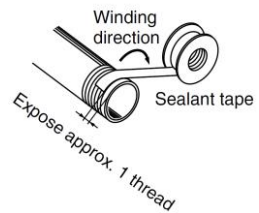

4. Closed center

For closed center, check the piping to prevent air leakage from the piping between the valve and the cylinder.

5. Piping to products

When piping to a product, avoid mistakes regarding the supply port, etc.

1) When using SMC's M3 or M5 fittings, follow the procedures below to tighten them.

• Connection thread: M3

First, tighten by hand, then use a suitable wrench to tighten the hexagonal portion of the body an additional 1/4 turn. The reference value for the tightening torque is 0.4 to 0.5 N·m.

• Connection thread: M5

First, tighten by hand, then use a suitable wrench to tighten the hexagonal portion of the body an additional 1/6 to 1/4 turn. The reference value for the tightening torque is 1 to 1.5 N·m.

* Excessive tightening may damage the thread portion or deform the gasket and cause air leakage. Insufficient tightening may loosen the threads or cause air leakage.

2) When using a fitting other than an SMC fitting, follow the instructions given by the fitting manufacturer.

6. Piping to products

When piping to a product, refer to the operation manual to avoid mistakes regarding the supply port, etc.



Precautions for 4 Port Solenoid Valve 4

Be sure to read before handling. Refer to main text for detailed precautions on every series.

Wiring

Warning

1. The solenoid valve is an electrical product. For safety, install an appropriate fuse and circuit breaker before use.

Caution

1. Polarity

When connecting power to a solenoid valve with a DC specification and equipped with a light or surge voltage suppressor, check for polarity. If there is polarity, take note of the following.

No diode to protect polarity.

If a mistake is made regarding the polarity, damage may occur to the diode in the valve, the switching element in a control device or power supply equipment, etc.

With diode to protect polarity.

If polarity connection is wrong, the valve will not operate.

2. Applied voltage

When electric power is connected to a solenoid valve, be careful to apply the proper voltage. Improper voltage may cause malfunction or coil damage.

3. Check the connections.

Check if the connections are correct after completing all wiring.

4. External force applied to the lead wire

If an excessive force is applied to the lead wire, this may cause faulty wiring. Take appropriate measures so that a force of 30 N or more is not applied to the lead wire. When instructions are given in the Specific Product Precautions, follow these specifications.

Lubrication

Warning

1. Lubrication

- 1) The valve has been lubricated for life by the factory and does not require any further.
- 2) If a lubricant is used in the system, use class 1 turbine oil (no additives), ISO VG32. For details about lubricant manufacturers' brands, refer to the SMC website. Additionally, please contact SMC for details about class 2 turbine oil (with additives) ISO VG32. Once lubricant is utilized within the system, since the original lubricant applied within the product during manufacturing will be washed away, please continue to supply lubrication to the system. Without continued lubrication, malfunctions could occur. If turbine oil is used, refer to the Safety Data Sheet (SDS) of the oil.

2. Lubrication amount

If the lubrication amount is excessive, the oil may accumulate inside the pilot valve, causing malfunction or response delay. So, do not apply a large amount of oil. When a large amount of oil needs to be applied, use an external pilot type to put the supply air on the pilot valve side in the non-lube state.

This prevents the accumulation of oil inside the pilot valve.

Air Supply

Warning

1. Type of fluids

Please consult with SMC when using the product in applications other than compressed air.

2. When there is a large amount of drainage.

Compressed air containing a large amount of drainage can cause malfunction of pneumatic equipment. An air dryer or water separator should be installed upstream from filters.

3. Drain flushing

If condensation in the drain bowl is not emptied on a regular basis, the bowl will overflow and allow the condensation to enter the compressed air lines. It causes malfunction of pneumatic equipment. If the drain bowl is difficult to check and remove, installation of a drain bowl with an auto drain option is recommended.

For compressed air quality, refer to SMC's Best Pneumatics catalog.

4. Use clean air

Do not use compressed air that contains chemicals, synthetic oils including organic solvents, salt or corrosive gasses, etc., as it can cause damage or malfunction.

Caution

1. When extremely dry air is used as the fluid, degradation of the lubrication properties inside the equipment may occur, resulting in reduced reliability (or reduced service life) of the equipment. Please consult with SMC.
2. Install an air filter.

Install an air filter upstream near the valve. Select an air filter with a filtration size of 5 μm or smaller.

3. Take measures to ensure air quality, such as by installing an aftercooler, air dryer, or water separator.

Compressed air that contains a large amount of drainage can cause the malfunction of pneumatic equipment, such as valves. Therefore, take appropriate measures to ensure air quality, such as by providing an aftercooler, air dryer, or water separator.

4. If an excessive amount of carbon powder is present, install a mist separator on the upstream side of the valve.

If excessive carbon dust is generated by the compressor, it may adhere to the inside of a valve and cause it to malfunction.

For compressed air quality, refer to the SMC Best Pneumatics catalog.



Precautions for 4 Port Solenoid Valve 5

Be sure to read before handling. Refer to main text for detailed precautions on every series.

Operating Environment

Warning

1. Do not use in an atmosphere containing corrosive gases, chemicals, sea water, water, water steam, or where there is direct contact with any of these.
2. Do not use in an environment where flammable gas or explosive gas exists. Usage may cause a fire or explosion. The products do not have an explosion proof construction.
3. Do not use in a place subject to heavy vibration and/or shock.
4. The valve should not be exposed to prolonged sunlight. Use a protective cover. Note that the valve is not for outdoor use.
5. Remove any sources of excessive heat.
6. If it is used in an environment where there is possible contact with oil, weld spatter, etc., exercise preventive measures.
7. When the solenoid valve is mounted in a control panel or it's energized for a long period of time, make sure the ambient temperature is within the specifications of the valve.

Caution

- 1. Temperature of ambient environment**
Use the valve within the range of the ambient temperature specification of each valve. In addition, pay attention when using the valve in environments where the temperature changes drastically.
- 2. Humidity of ambient environment**
 - When using the valve in environments with low humidity, take measures to prevent static.
 - If the humidity rises, take measures to prevent the adhesion of water droplets on the valve.

Maintenance

Warning

- 1. Perform maintenance and inspection according to the procedures indicated in the operation manual.**
If handled improperly, human injury and/or malfunction or damage of machinery and equipment may occur.
- 2. Removal of equipment, and supply/exhaust of compressed air**
Before components are removed, first confirm that measures are in place to prevent workpieces from dropping, run-away equipment, etc. Then, cut off the supply air and electric power, and exhaust all air pressure from the system using the residual pressure release function.
For the 3-position closed center, exhaust the residual pressure between the valve and the cylinder. When the equipment is operated after remounting or replacement, first confirm that measures are in place to prevent the lurching of actuators, etc. Then, confirm that the equipment is operating normally. In particular, when a 2-position double solenoid valve is used, releasing residual pressure rapidly may cause the spool valve to malfunction, depending on the piping conditions, or the connected actuator to operate.

3. Low-frequency operation

Valves should be operated at least once every 30 days to prevent malfunction. (Use caution regarding the air supply.)

4. Manual override

When a manual override is operated, connected equipment will be actuated.

Operate only after safety is confirmed.

5. If the volume of air leakage increases or the valve does not operate normally, do not use the valve.

Perform periodic maintenance on the valve to confirm the operating condition and check for any air leakage.

Caution

1. Drain flushing

Remove drainage from the air filters regularly.

2. Lubrication

In the case of rubber seals, once lubrication has been started, it must be continued.

Use class 1 turbine oil (with no additives), VG32. If other lubricant oil is used, it may cause a malfunction. Please contact SMC for information on the suggested class 2 turbine oil (with additives), VG32.

3. Manual override operation

When switching a double solenoid valve via the manual override operation, instantaneous operation may cause the malfunction of the cylinder. It is recommended that the manual override be held until the cylinder reaches the stroke end position.

UL approved

Caution

When conformity to UL is required, the SI unit should be used with a UL 1310 Class 2 power supply.

The SI unit is a UL approved product only if they have a  mark on the body.



SJ1000/2000/3000 series

Specific Product Precautions 1

Be sure to read this before handling.

Manual Override Switch Operation

Warning

For manual override operation, move the manual override switch to a position where letters A and B can be seen. [Manual override switch release status (refer to the figure below)] Operation with the manual override switch in a locked status can cause damage to the manual override and air leakage, so be sure to release the manual override switch before use. After manual override operation, lock the manual switch for use (when the manual override of the push-turn locking slotted type is locked, a manual override switch cannot be locked).



Manual override switch locked status

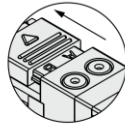

Manual override switch unlocked status

Manual override switch slide direction

Manual Override Operation

Warning

When the manual override is operated, connected equipment will be actuated. Confirm safety before operating.

Non-locking push type

Press in the direction of the arrow.

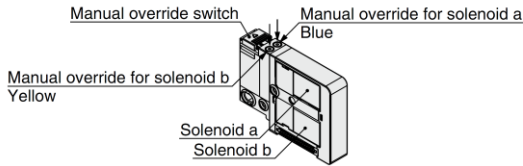

Push-turn locking slotted type

While pressing, turn in the direction of the arrow (90° clockwise). If it is not turned, it can be used in the same way as the non-locking push type.

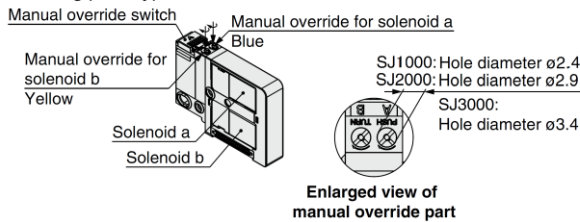

Slide locking type (manual override)

Slide the manual override all the way to the ON side in the arrow direction. The manual override is then locked. To unlock the manual override, slide it toward the OFF side in the arrow direction.

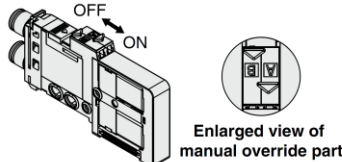

Caution

When you operate the D type with a screw driver, turn it gently using a precision screwdriver. [Torque: under 0.05 N·m] When you lock the manual override of the D type, be sure to push it before turning. [Load: 10 N or less] Turning without pushing can cause damage to the manual override and trouble such as air leakage, etc.

Valve with Switch

Warning

When turning OFF the valve using the switch, move it to the position where the valve is locked. If the switch is at an improper position and is energized, equipment connected to the valve could be actuated. Also, if the switch is turned OFF on the valve in the energized state, be careful because any actuators connected to a single solenoid, a dual 3 port valve or a 3 position valve will actuate.

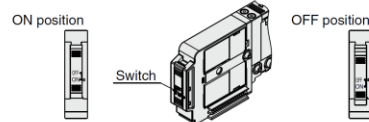

Normal operation: The valve is switched according to electric signals from the connector on the manifold side.

The valve coil is kept in a deenergized state even when there is an electric signal from the connector on the manifold side.

Electric circuit diagram (with positive common and light/surge voltage suppressor)

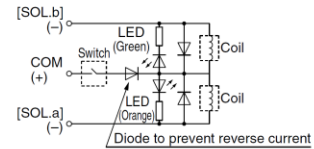

(with negative common and light/surge voltage suppressor)

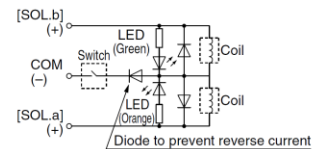

Built-in Back Pressure Check Valve Type

Caution

1. Valves with built-in back pressure check valve is to protect the back pressure inside a valve. For this reason, use caution the valves with external pilot specification cannot be pressurized from exhaust port [3/5(E)]. As compared with the types which do not integrate the back pressure check valve, C value of the flow rate characteristics (sonic conductance) goes down. For details, please contact SMC.
2. Do not switch valves when A or B port is open to the atmosphere, or while the actuators and air operated equipment are in operation. The back pressure prevention seal may be peeled off, which may cause air leakage or malfunctions. Use caution especially when performing a trial operation or maintenance work.



SJ1000/2000/3000 series Specific Product Precautions 2

Be sure to read this before handling.

Exhaust Restriction

Caution

Since the SJ series is a type in which the pilot valve exhaust joins the main valve exhaust inside the valve, use caution, so that the piping from the exhaust port is not restricted.

When Using a 4 Port Valve as a 3 Port Valve

Caution

When using a 4 port valve as a 3 port valve

The SJ1000/2000/3000 series can be used as normally closed (N.C.) or normally open (N.O.) 3 port valves by plugging one of the cylinder ports 4(A) or 2(B). However, exhaust ports should be left open. It is convenient when a double solenoid 3 port valve is required.

Plug position		2(B) port	4(A) port
Type of actuation		N.C.	N.O.
Number of solenoids	Single		
	Double		

Light/Surge Voltage Suppressor

Caution

Non-polar type

Single solenoid

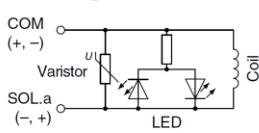

Double solenoid, 3 position type

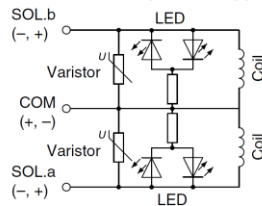

Positive common

Single solenoid

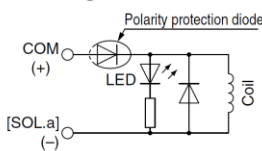

Double solenoid, 3 position type

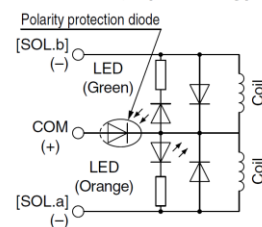

Negative common

Single solenoid

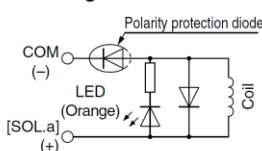

Double solenoid, 3 position type

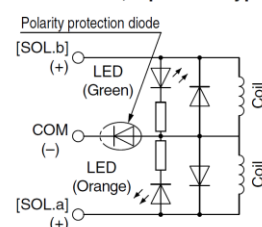

With power saving circuit

Caution

With power saving circuit

Compared to the standard products, power consumption is reduced down to approx. 1/3 (in case of SJ3□60T) by cutting the unnecessary wattage required to hold the valve in an energized state. (Effective energizing time is over 67 ms at 24 VDC.)

Electric circuit diagram (with power saving circuit) In case of positive common, single solenoid

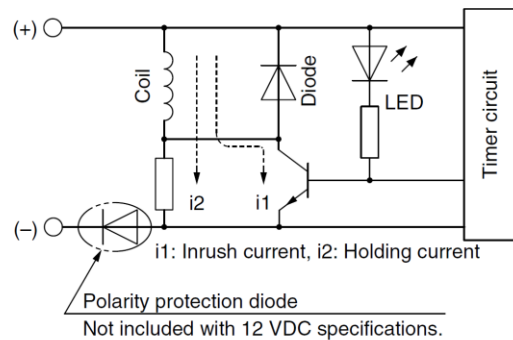

In case of negative common, single solenoid

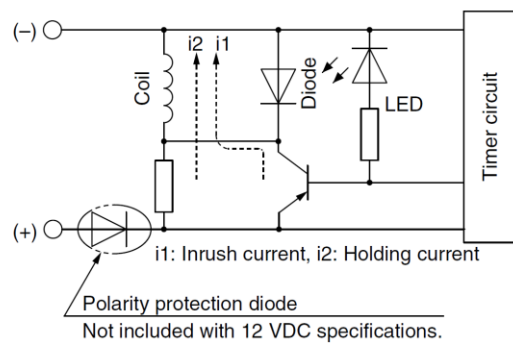



SJ1000/2000/3000 series Specific Product Precautions 3

Be sure to read this before handling.

Working Principle

With the circuit of page 9, the current consumption, when holding, is reduced to save energy. Please refer to the electric wave form data below.

In case of SJ3□60T, electric waveform of energy saving type

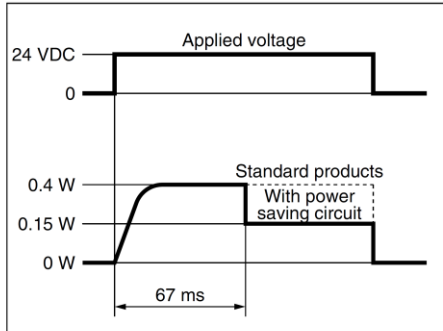

In case of SJ $\frac{1}{2}$ □60T, electric waveform of energy saving type

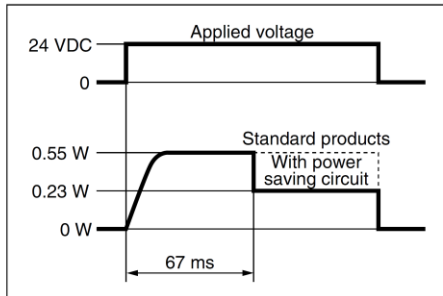

- When a power saving circuit is installed, a diode to prevent reverse current is not available for 12 VDC spec. Therefore, use caution not to connect in reverse.
- Be careful about the allowable voltage fluctuation since a voltage drop of about 0.5 V occurs due to a transistor. (Refer to the solenoid specifications of each valve for details.)

Measures to prevent detours of surge voltage

When the DC power supply is shut off, by the emergency breaking circuit for example, valve misoperation may occur due to surge voltage produced by other electrical parts (such as electromagnetic coils). Please take measures to prevent surges from detouring to the valve (surge protection diode etc.), or use a valve with diode to prevent reverse current (polar: Z type).

However, surge countermeasures are provided on the serial unit side of the serial type.

Circuit example

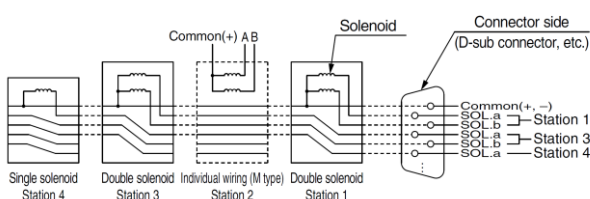

Light Indication

Caution

When equipped with light/surge voltage suppressor, the light window turns orange when solenoid a is energized, and it turns green when solenoid b is energized.

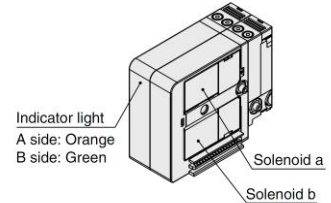

Changing the Connector Entry Direction

Caution

To change the connector's entry direction, set the switch on the top of the connector block to the FREE position, before turning the connector. Make sure to set the switch back to the LOCK position before connecting the connector. (When the switch is difficult to slide, move the connector a little so that it will slide easier.)

If an excessive force is applied on the connector in the LOCK position, the connector block may be damaged. Also, using in such a way that the connector floats in the FREE position, it may cause the lead wire, etc. to break. Thus, refrain from using in these ways.

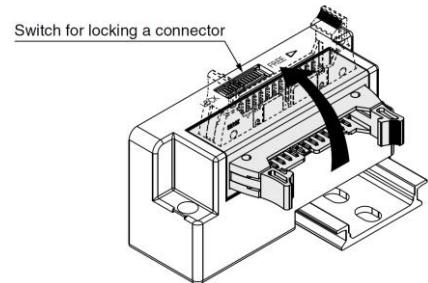

Manifold Mounting

When attaching a manifold to a mounting surface, etc., with bolts, if the entire bottom surface of the DIN rail contacts the mounting surface in a horizontal mounting, it can be used by simply securing both ends of the DIN rail. However, for any other mounting method or for side facing and down facing, etc., secure the DIN rail with bolts at uniform intervals using the following as a guide: 2 to 5 stations at 2 locations, 6 to 10 stations at 3 locations, 11 to 15 stations at 4 locations, 16 to 20 stations at 5 locations, 21 to 25 stations at 6 locations, 26 to 30 stations at 7 locations and more than 30 stations at 8 locations.

In addition, even in the case of a horizontal mounting, if the mounting surface is subject to vibration, etc., take the same measures indicated above. If secured at fewer than the specified number of locations, warping or twisting may occur in the DIN rail and manifold, causing trouble such as air leakage.



SJ1000/2000/3000 series

Specific Product Precautions 4

Be sure to read this before handling.

Fitting Replacement

Caution

By replacing a valve's fitting assembly, it is possible to change the port size of the 4(A), 2(B), 1(P), and 3/5(E) ports. When replacing it, pull out the fitting assembly after removing the clip with a flat blade screw driver, etc. To mount a new fitting assembly, insert it into place and then fully reinsert the clip.

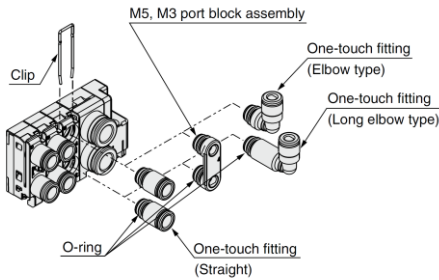

Fitting Assembly Part No.

Metric Size

Port	Port size	Part no.
SJ1000 4(A) 2(B)	ø2 One-touch fitting (Straight)	KQSY10-C2
	ø4 One-touch fitting (Straight)	KQSY10-C4-X1336
SJ2000 4(A) 2(B)	ø2 One-touch fitting (Straight)	KJH02-C1
	ø4 One-touch fitting (Straight)	KJH04-C1
	ø2 One-touch fitting (Elbow type)	KJL02-C1
	ø4 One-touch fitting (Elbow type)	KJL04-C1-N
	ø2 One-touch fitting (Long elbow type)	KJW02-C1
	ø4 One-touch fitting (Long elbow type)	KJW04-C1-N
	M3 port block assembly	SJ2000-56-1A
SJ3000 4(A) 2(B)	ø2 One-touch fitting (Straight)	KJH02-C2
	ø4 One-touch fitting (Straight)	KJH04-C2
	ø6 One-touch fitting (Straight)	KJH06-C2
	ø2 One-touch fitting (Elbow type)	KJL02-C2
	ø4 One-touch fitting (Elbow type)	KJL04-C2
	ø6 One-touch fitting (Elbow type)	KJL06-C2-N
	ø2 One-touch fitting (Long elbow type)	KJW02-C2
	ø4 One-touch fitting (Long elbow type)	KJW04-C2
	ø6 One-touch fitting (Long elbow type)	KJW06-C2-N
		M5 port block assembly
1(P) 3/5(E)	ø6 One-touch fitting (Straight)	VVQ1000-51A-C6
	ø6 One-touch fitting (Elbow type)	SZ3000-74-1A-L6
	ø6 One-touch fitting (Long elbow type)	SZ3000-74-2A-L6
	ø8 One-touch fitting (Straight)	VVQ1000-51A-C8
	ø8 One-touch fitting (Elbow type)	SZ3000-74-1A-L8
	ø8 One-touch fitting (Long elbow type)	SZ3000-74-2A-L8

Inch Size

Port	Port size	Part no.
SJ2000 4(A) 2(B)	ø1/8" One-touch fitting (Straight)	KJH01-C1
	ø5/32" One-touch fitting (Straight)	KJH03-C1
	ø1/8" One-touch fitting (Elbow type)	KJL01-C1
	ø5/32" One-touch fitting (Elbow type)	KJL03-C1
	ø1/8" One-touch fitting (Long elbow type)	KJW01-C1
	ø5/32" One-touch fitting (Long elbow type)	KJW03-C1
SJ3000 4(A) 2(B)	ø1/8" One-touch fitting (Straight)	KJH01-C2
	ø5/32" One-touch fitting (Straight)	KJH03-C2
	ø1/4" One-touch fitting (Straight)	KJH07-C2
	ø1/8" One-touch fitting (Elbow type)	KJL01-C2
	ø5/32" One-touch fitting (Elbow type)	KJL03-C2
	ø1/4" One-touch fitting (Elbow type)	KJL07-C2
	ø1/8" One-touch fitting (Long elbow type)	KJW01-C2
	ø5/32" One-touch fitting (Long elbow type)	KJW03-C2
	ø1/4" One-touch fitting (Long elbow type)	KJW07-C2
	1(P) 3/5(E)	ø1/4" One-touch fitting (Straight)
ø5/16" One-touch fitting (Straight)		VVQ1000-51A-N9

Note 1) To change the port size of the 1(P), 3/5(E) ports into the port sizes other than ø8 (straight), specify the change by means of the manifold specification sheet.

Note 2) Be careful to avoid damage or contamination to the O-rings, as this can cause air leakage.

Note 3) When removing a straight-type fitting from a valve, after removing the clip, attach tubing or a plug (KJP-02, KQ2P-□□) to the One-touch fitting, and pull it out while holding the tubing or plug. If it is pulled out while holding the release button of the fitting (resin part), the release button may be damaged.

Note 4) Be sure to turn off the power and stop the supply of air before disassembly. Furthermore, since air may remain inside the actuator, piping and manifold, confirm that the air is completely exhausted before starting any work.

Note 5) While inserting a tubing into an elbow-type fitting, hold the main body of the fitting by hand. Failure to do so will exert an undue force on the valve or the fitting, resulting in air leakage or damage.

Note 6) Each fitting assembly part no. contains 1 pc. Additionally, when the piping is constructed in the same direction using the elbow-type fitting, order the elbow-type and/or long elbow-type fitting.

Clip Part No.

Part no.			Note
SJ1000	SJ2000	SJ3000	
SJ1000-CL-1	SJ2000-CL-1	SJ3000-CL-1	These part numbers contain 10 pcs. each.

O-ring for Valve Connection (Common to SJ1000/2000/3000)

Part no.	Note
SJ3000-96-1A	The part numbers shown on the left includes parts for 5 units. (10 pcs. each for P, E port and X, PE port)



SJ1000/2000/3000 series Specific Product Precautions 5

Be sure to read this before handling.

One-touch Fittings

Caution

The pitch of the SJ series piping ports (A, B etc.) has been set assuming the use of KJ series One-touch fittings. Therefore, when using fittings with an M3 or M5 port block assembly, there may be some interference between fittings, depending on the type and size, so please use after checking dimensions in the catalog for the pipe fitting being used.

1. Tube attachment/detachment for One-touch fittings

1) Tube attachment

(1) Take a tube having no flaws on its periphery and cut it off at a right angle. When cutting the tube, use tube cutters TK-1, 2 or 3. Do not use pinchers, nippers or scissors, etc. If cutting is done with tools other than tube cutters, the tube may be cut diagonally or become flattened, etc., making a secure installation impossible, and causing problems such as the tube pulling out after installation or air leakage.

Also allow some extra length in the tube.

(2) Grasp the tube and push it in slowly, inserting it securely all the way into the fitting.

(3) After inserting the tube, pull on it lightly to confirm that it will not come out. If it is not installed securely all the way into the fitting, this can cause problems such as air leakage or the tube pulling out.

2) Tube detachment

(1) The 4(A) and 2(B) ports use the KJ series, so the tube can be removed by pressing on part of the release button. However, for the 1(P) and 3/5(E) ports, please press the release button evenly as before.

(2) Pull out the tube while holding down the release button so that it does not come out. If the release button is not pressed down sufficiently, there will be increased bite on the tube and it will become more difficult to pull it out.

(3) When the removed tube is to be used again, cut off the portion which has been chewed before reusing it. If the chewed portion of the tube is used as is, this can cause trouble such as air leakage or difficulty in removing the tube.

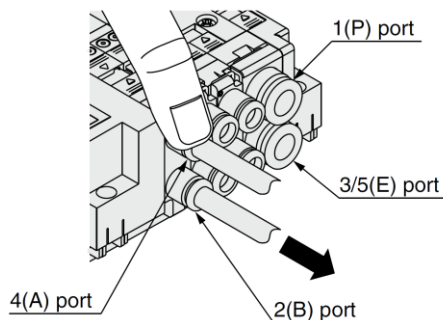

Hold down part of the release button with your finger or a similar tool, as shown in the diagram, and pull out in the direction indicated by the arrow.

Other Tube Brands

Caution

1. When using other than SMC brand tube, confirm that the following specifications are satisfied with respect to the tube outside diameter tolerance.

- 1) Nylon tube within ± 0.1 mm
- 2) Soft nylon tube within ± 0.1 mm
- 3) Polyurethane tube within $+0.15$ mm, within -0.2 mm

Do not use tube which does not meet these outside diameter tolerances. It may not be possible to connect them, or they may cause other trouble, such as air leakage or the tube pulling out after connection.

How to Use Plug Connector

Caution

When attaching and detaching a connector, first shut off the electric power and the air supply. Also, crimp the lead wires and sockets securely.

1. Connector attachment/detachment

- To attach a connector, hold the lever and connector unit between your fingers and insert straight onto the pins of the solenoid valve so that the lever's pawl is pushed into the groove and locks.
- To detach a connector, remove the pawl from the groove by pushing the lever downward with your thumb, and pull the connector straight out.

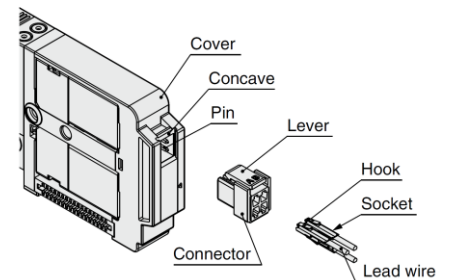

2. Crimping of lead wires and sockets

Peel 3.2 to 3.7 mm of the tip of lead wire, enter the core wires neatly into a socket and crimp it with a special crimp tool. Be careful so that the cover of lead wire does not enter into the crimping part. (Please contact SMC for the dedicated crimping tools.)

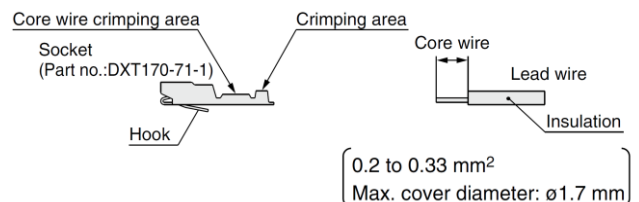



SJ1000/2000/3000 series Specific Product Precautions 6

Be sure to read this before handling.

How to Use Plug Connector

Caution

3. Lead wires with sockets attachment/detachment

· Attachment

Insert the sockets into the square holes of the connector (with A, B, C, and N indication), and continue to push the sockets all the way in until the lock by hooking into the seats in the connector. (When they are pushed in, their hooks open and they are locked automatically.) Next, confirm that they are locked by pulling lightly on the lead wires.

· Detachment

To detach a socket from a connector, pull out the lead wire while pressing the socket's hook with a stick having a thin tip (approx. 1 mm). If the socket is used again, spread the hook outward.

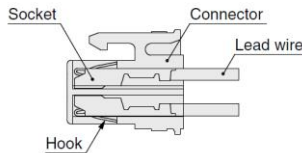

<Positive common>

Single solenoid

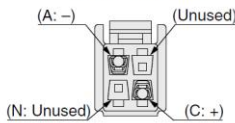

Double solenoid

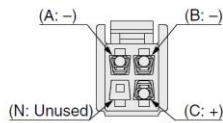

<Negative common>

Single solenoid

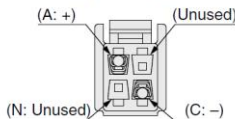

Double solenoid

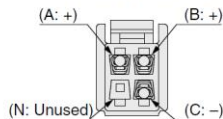

Plug Connector Lead Wire Length

Caution

Plug connector lead wires have a standard length of 300 mm, however, the following lengths are also available.

Connector Assembly Part No.

Single solenoid

SJ3000-46-S-□ (for positive common)

SJ3000-47-S-□ (for negative common)

Double solenoid, 3 position type, 4 position type

SJ3000-46-D-□ (for positive common)

SJ3000-47-D-□ (for negative common)

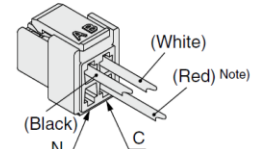
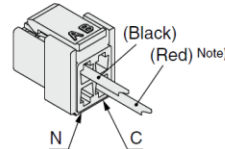
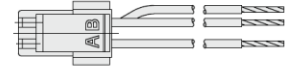
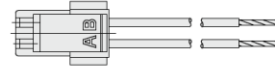

Note) In case of negative common, the lead wire changes from red to yellow.

For single solenoid:

SJ3000-46-S-□

For double solenoid

SJ3000-46-D-□

For 3 position type :

For 4 position type

Common specifications

46	For positive common
47	For negative common

Lead wire length

Nil	300 mm
6	600 mm
10	1000 mm
15	1500 mm
20	2000 mm
25	2500 mm
30	3000 mm
50	5000 mm

For single solenoid

Without lead wire : SJ3000-46-S-N (positive/negative common)

(Connector, Socket x 2 pcs. only)

For double solenoid

Without lead wire : SJ3000-46-D-N (positive/negative common)

(Connector, Socket x 3 pcs. only)

How to Order

Include the connector assembly part number together with the part number for the plug connector's solenoid valve without connector.

(Example) In case of lead wire length 2000 mm and positive common
 SJ3160-5MOZ-C6
 SJ3000-46-S-20

Connector Assembly for Manifolds (for Junction Common)

Caution

Using the connector assembly (for junction common) for solenoid valves installed in the manifold reduces the labor involved in wiring work because common wiring for all solenoid valves is integrated into a single wire.



SJ1000/2000/3000 series Specific Product Precautions 7

Be sure to read this before handling.

Connector Assembly Part No. (for Junction Common)

Single solenoid

SJ3000-46-SC-□ (for positive common)
SJ3000-47-SC-□ (for negative common)

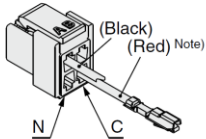
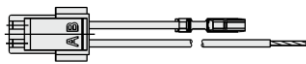

Double solenoid,
3 position type, 4 position type

SJ3000-46-DC-□ (for positive common)
SJ3000-47-DC-□ (for negative common)

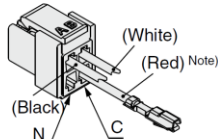
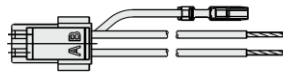

Note) In case of negative common, the lead wire changes from red to yellow.

For single solenoid:	SJ3000-46-SC-□	Lead wire length
		Nil 300 mm
		6 600 mm
		10 1000 mm
		15 1500 mm
		20 2000 mm
		25 2500 mm
		30 3000 mm
		50 5000 mm

For double solenoid	SJ3000-46-DC-□
For 3 position type :	
For 4 position type	

Common specifications	
46	For positive common
47	For negative common

For junction common

How to Order

Indicate the part no. of the connector assembly with the part numbers of the manifold and solenoid valves.

If the arrangement is complicated, please specify them by means of the manifold specification sheet.

Note 1) Applications like connectors not wired to a valve is not possible.

Note 2) For the solenoid valve, please designate "No connector (MOZ)" for the connector type.

Note 3) Connector assembly with lead wire for place where the signals are transmitted to the common wiring. (Only the valves of first station and/or last station of manifold are compatible to connector with lead wire for common.)

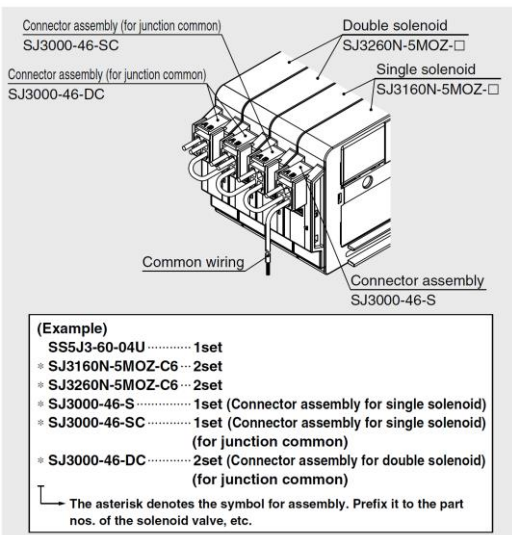

Wiring Instructions for Connector Assembly (for Junction Common)

Caution

If only connector assembly (for junction common) is ordered, please wire according to the instructions in the diagram below. For details on socket mounting, please refer to "How to Use Plug Connector" on page 13.

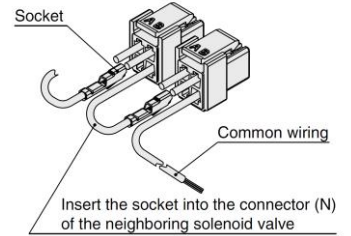

One-touch Fittings

Caution

When fittings are used, they may interfere with one another depending on their types and sizes. Therefore, the dimensions of the fittings to be used should first be confirmed in their respective catalogs. Fittings whose compliance with the SJ series is already confirmed are stated below. If the fitting within the applicable range is selected, there will not be any interference.

Applicable Fittings: KQ2H, KQ2S Series
KJH, KJS Series

Series	Model	Piping port	Port size	Fitting	Applicable tubing O.D.			
					e2	e3.2	e4	e6
SJ3000 (10 mm pitch)	SJ3□60-□□-M5	4A, 2B	M5	KQ2H KJH	[Shaded area]			
				KQ2S KJS	[Shaded area]			
SJ2000 (7.5 mm pitch)	SJ2□60-□□-M3	4A, 2B	M3	KQ2H KJH	[Shaded area]			
				KQ2S KJS	[Shaded area]			
SJ3A6 (10 mm pitch)	SJ3A6-□□	2B	M5	KQ2H KJH	[Shaded area]			
				KQ2S KJS	[Shaded area]			

How to Wire to PC Wiring System Compliant Power Supply Terminal

Caution

Wire connection instructions

- Strip 6.5 to 7.5 mm from the tip of the lead wire.
- Loosen the terminal screws (slotted screws) of the power supply terminal connectors, plug the core wire of the lead wire into the square holes of the connector, tighten terminal screws at the proper torque, and fasten them securely. (Gently pull the lead wire and check that it is fastened.)

Precautions

- To remove the power supply terminal connector, pull it upward as is. When mounting, push it in until it makes a snapping noise.
- When connecting wire, be careful because using lead wire that is outside of compatible lead wire ranges, or that are tightened to anything other than the proper torque, creates a risk of defective contact and other problems.

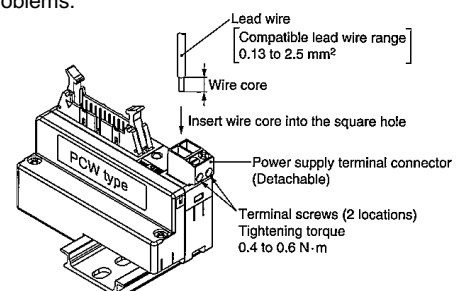

SJ1000/2000/3000 Series Construction 1

SJ1000/2000: Connector Type

Symbol

2 position single

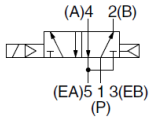

2 position single with back pressure check valve

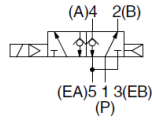

2 position double

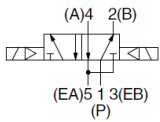

2 position double with back pressure check valve

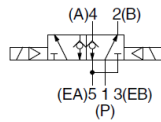

3 position closed center

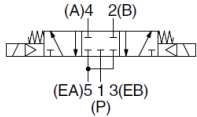

3 position exhaust center

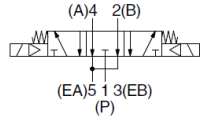

3 position pressure center

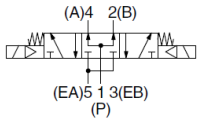

2 position single

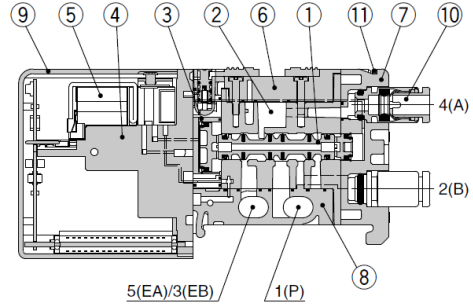

2 position double

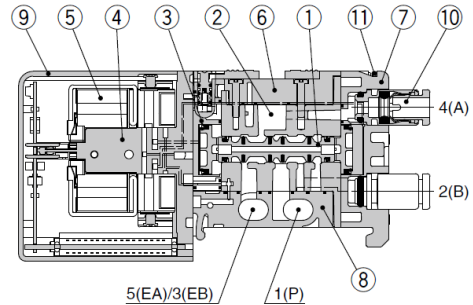

3 position closed center/exhaust center/pressure center

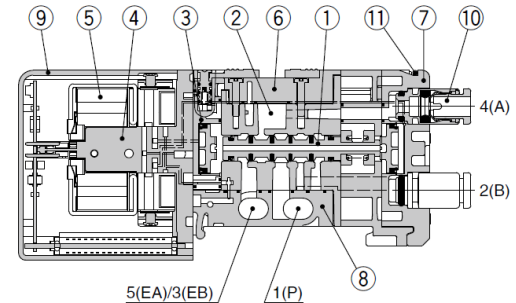

Component Parts

No.	Description	Material	Note
1	Spool valve assembly	Resin/HNBR (3 position solenoid valve: Aluminum/HNBR)	—
2	Body	Zinc die-cast	—
3	Adapter plate	Resin	White
4	Pilot adapter	Resin	White
5	Pilot valve assembly	—	—
6	Body cover	Resin	White
7	Port block	Resin	White
8	Bottom cover	Resin	White
9	Light cover	Resin	Light blue

Replacement Parts

No.	Description	Part no.
10	One-touch fitting	Refer to the One-touch fitting part no. on page 11.
11	Clip	SJ1000: SJ1000-CL-1 (10 pcs.) SJ2000: SJ2000-CL-1 (10 pcs.)

SJ₂260K with back pressure check valve

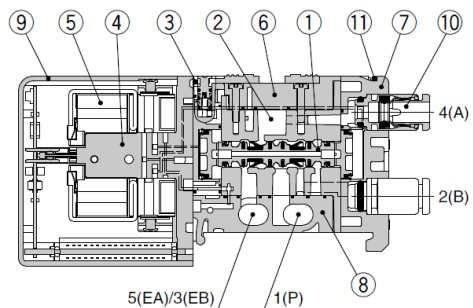

SJ1000/2000/3000 Series Construction 2

SJ1000/2000: Connector Type

Symbol

4 position dual 3 port valve
SJ $\frac{1}{2}$ A60 [N.C. valve x 2]

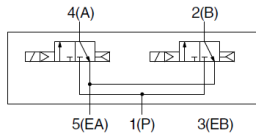

SJ $\frac{1}{2}$ A60K with back pressure check valve

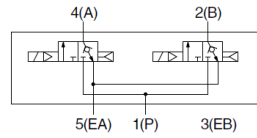

SJ $\frac{1}{2}$ B60 [N.O. valve x 2]

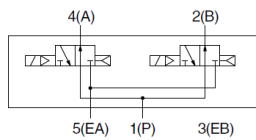

SJ $\frac{1}{2}$ B60K with back pressure check valve

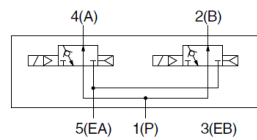

SJ $\frac{1}{2}$ C60 [N.C., N.O. valve x 1 (each)]

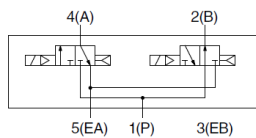

SJ $\frac{1}{2}$ C60K with back pressure check valve

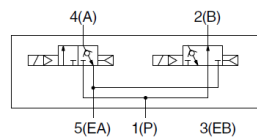

SJ $\frac{1}{2}$ A60 [N.C. valve x 2]

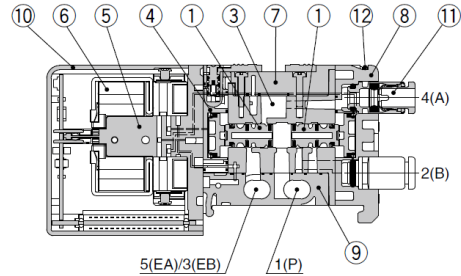

SJ $\frac{1}{2}$ B60 [N.O. valve x 2]

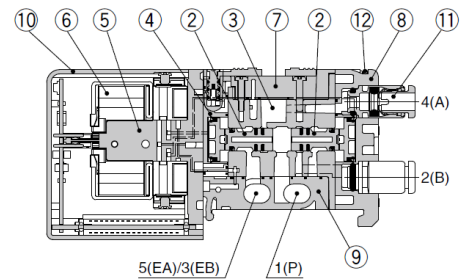

SJ $\frac{1}{2}$ C60 [N.C. valve, N.O. valve x 1 (each)]

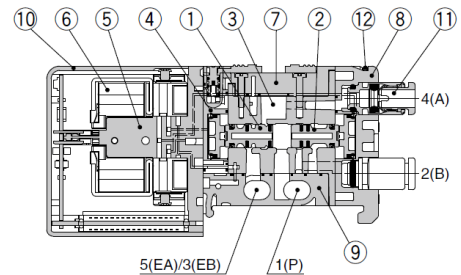

Component Parts

No.	Description	Material	Note
1	Spool valve assembly	Resin/HNBR	N.C. (Normally closed)
2	Spool valve assembly	Resin/HNBR	N.O. (Normally open)
3	Body	Zinc die-cast	—
4	Adapter plate	Resin	White
5	Pilot adapter	Resin	White
6	Pilot valve assembly	—	—
7	Body cover	Resin	White
8	Port block	Resin	White
9	Bottom cover	Resin	White
10	Light cover	Resin	Light blue

Replacement Parts

No.	Description	Part no.
11	One-touch fitting	Refer to the One-touch fitting part no. on page 11.
12	Clip	SJ1000: SJ1000-CL-1 (10 pcs.) SJ2000: SJ2000-CL-1 (10 pcs.)

SJ $\frac{1}{2}$ A60K with back pressure check valve

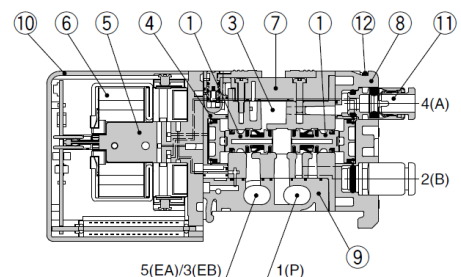

SJ3000: Connector Type

Symbol

2 position single

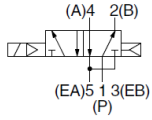

2 position single with back pressure check valve

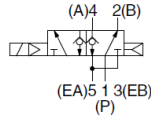

2 position double

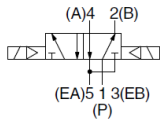

2 position double with back pressure check valve

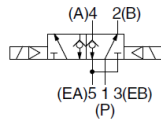

3 position closed center

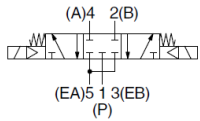

3 position exhaust center

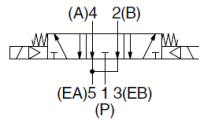

3 position pressure center

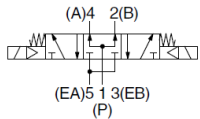

2 position single

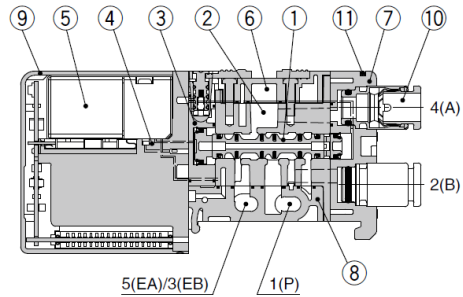

2 position double

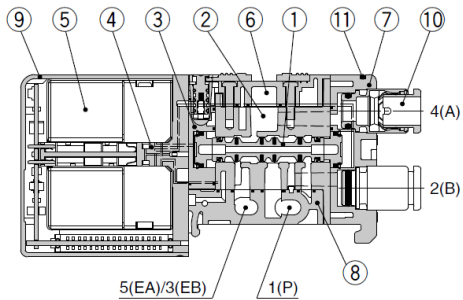

3 position closed center/exhaust center/pressure center

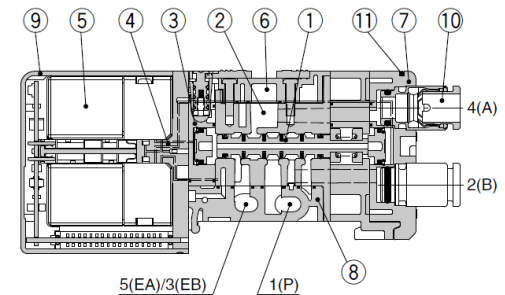

Component Parts

No.	Description	Material	Note
1	Spool valve assembly	Resin/HNBR (3 position solenoid valve: Aluminum/HNBR)	—
2	Body	Zinc die-cast	—
3	Adapter plate	Resin	White
4	Pilot adapter	Resin	White
5	Pilot valve assembly	—	—
6	Body cover	Resin	White
7	Port block	Resin	White
8	Bottom cover	Resin	White
9	Light cover	Resin	Light blue

Replacement Parts

No.	Description	Part no.
10	One-touch fitting	Refer to the One-touch fitting part no. on page 11.
11	Clip	SJ3000-CL-1 (10 pcs.)

SJ3260K with back pressure check valve

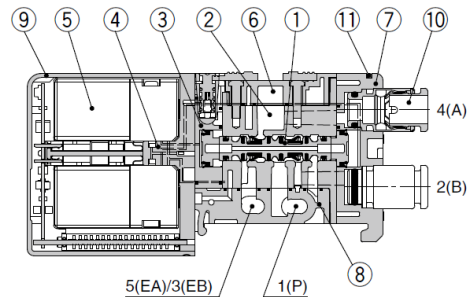

SJ1000/2000/3000 Series Construction 3

SJ3000: Connector Type

Symbol

4 position dual 3 port valve
SJ3A60 [N.C. valve x 2]

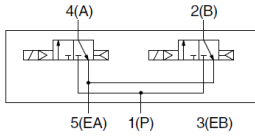

SJ3A60K with back pressure
check valve

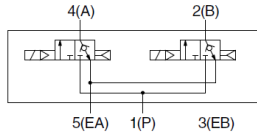

SJ3A60 [N.C. valve x 2]

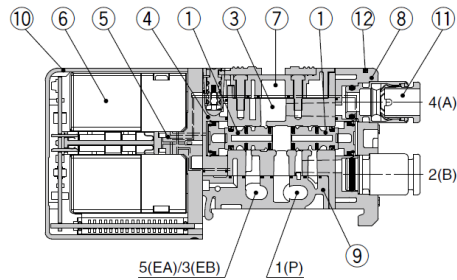

SJ3B60 [N.O. valve x 2]

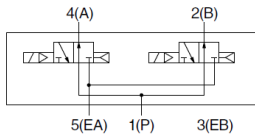

SJ3B60K with back pressure
check valve

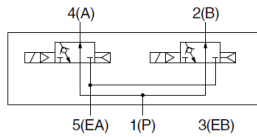

SJ3B60 [N.O. valve x 2]

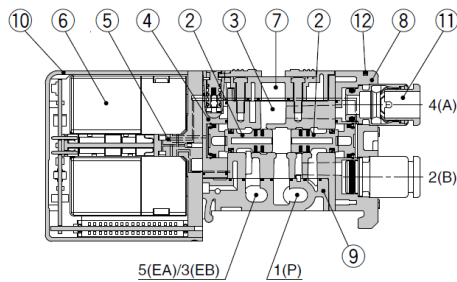

SJ3C60 [N.C., N.O. valve x 1
(each)]

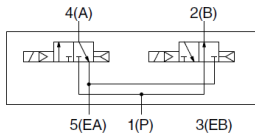

SJ3C60K with back pressure
check valve

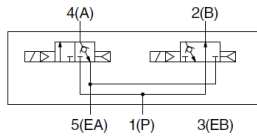

SJ3C60 [N.C. valve, N.O. valve x 1 (each)]

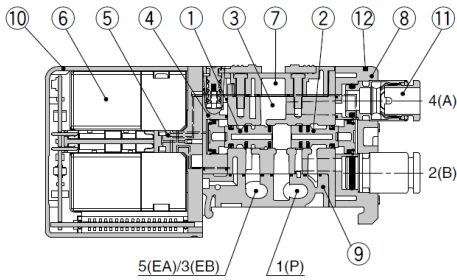

Component Parts

No.	Description	Material	Note
1	Spool valve assembly	Resin/HNBR	N.C. (Normally closed)
2	Spool valve assembly	Resin/HNBR	N.O. (Normally open)
3	Body	Zinc die-cast	—
4	Adapter plate	Resin	White
5	Pilot adapter	Resin	White
6	Pilot valve assembly	—	—
7	Body cover	Resin	White
8	Port block	Resin	White
9	Bottom cover	Resin	White
10	Light cover	Resin	Light blue

Replacement Parts

No.	Description	Part no.
11	One-touch fitting	Refer to the One-touch fitting part no. on page 11.
12	Clip	SJ3000-CL-1 (10 pcs.)

SJ3A60K with back pressure check valve

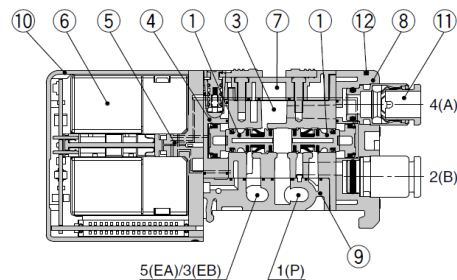

SJ2000: Cable Type

Symbol

2 position single

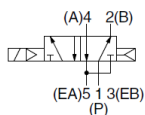

2 position single with back pressure check valve

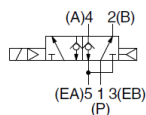

2 position double

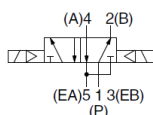

2 position double with back pressure check valve

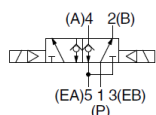

3 position closed center

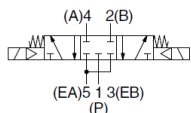

3 position exhaust center

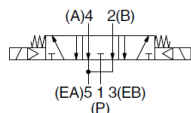

3 position pressure center

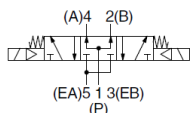

2 position single

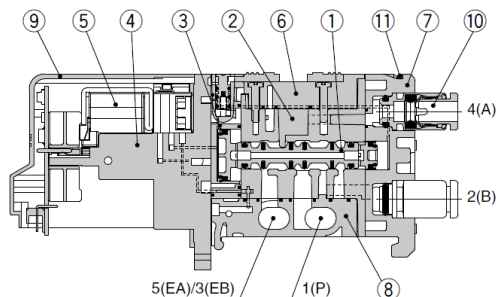

2 position double

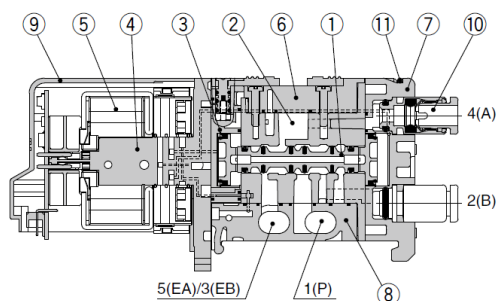

3 position closed center/exhaust center/pressure center

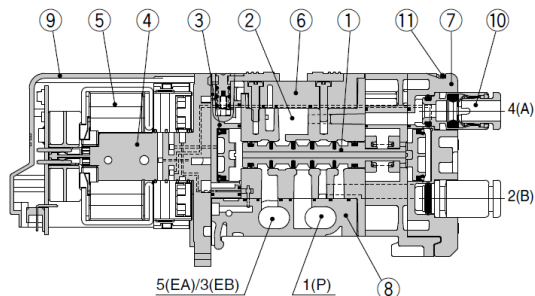

Component Parts

No.	Description	Material	Note
1	Spool valve assembly	Resin/HNBR (3 position solenoid valve: Aluminum/HNBR)	—
2	Body	Zinc die-cast	—
3	Adapter plate	Resin	White
4	Pilot adapter	Resin	White
5	Pilot valve assembly	—	—
6	Body cover	Resin	White
7	Port block	Resin	White
8	Bottom cover assembly	Resin	White
9	Light cover	Resin	Light blue

Replacement Parts

No.	Description	Part no.
10	One-touch fitting	Refer to the One-touch fitting part no. on page 11.
11	Clip	SJ2000-CL-1 (10 pcs.)

SJ2260K with back pressure check valve

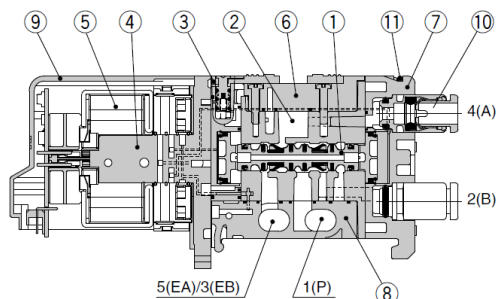

SJ1000/2000/3000 Series Construction 4

SJ2000: Cable Type

Symbol

4 position dual 3 port valve
SJ2A60 [N.C. valve x 2]

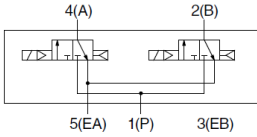

SJ2A60K with back pressure
check valve

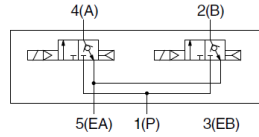

SJ2B60 [N.O. valve x 2]

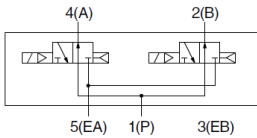

SJ2B60K with back pressure
check valve

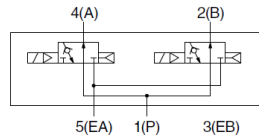

SJ2C60 [N.C., N.O. valve x 1
(each)]

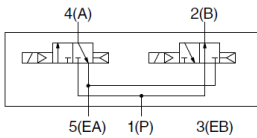

SJ2C60K with back pressure
check valve

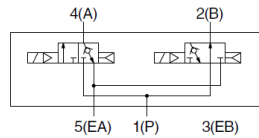

SJ2A60 [N.C. valve x 2]

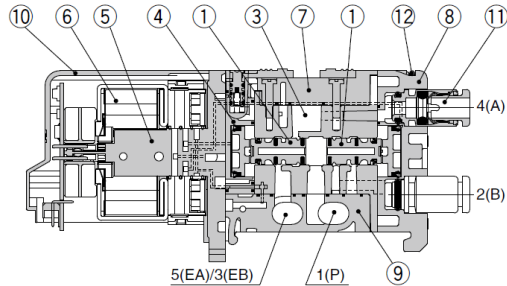

SJ2B60 [N.O. valve x 2]

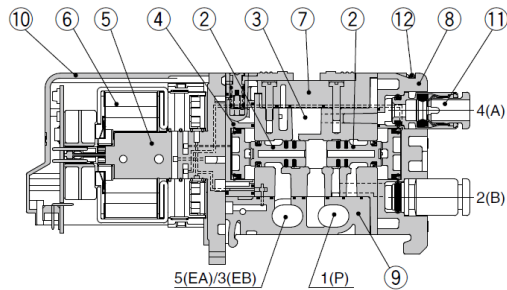

SJ2C60 [N.C. valve, N.O. valve x 1 (each)]

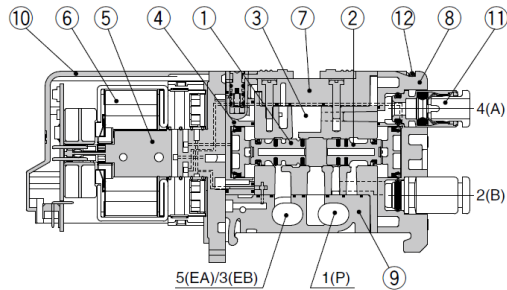

Component Parts

No.	Description	Material	Note
1	Spool valve assembly	Resin/HNBR	N.C. (Normally closed)
2	Spool valve assembly	Resin/HNBR	N.O. (Normally open)
3	Body	Zinc die-cast	—
4	Adapter plate	Resin	White
5	Pilot adapter	Resin	White
6	Pilot valve assembly	—	—
7	Body cover	Resin	White
8	Port block	Resin	White
9	Bottom cover assembly	Resin	White
10	Light cover	Resin	Light blue

Replacement Parts

No.	Description	Part no.
11	One-touch fitting	Refer to the One-touch fitting part no. on page 11.
12	Clip	SJ2000-CL-1 (10 pcs.)

SJ2A60K with back pressure
check valve

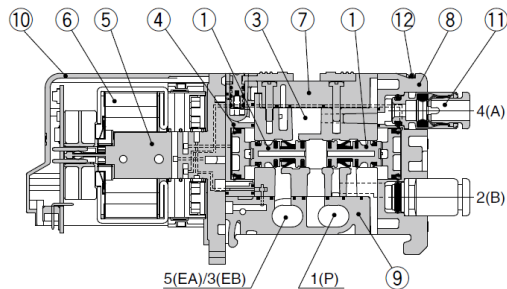

SJ3000: Cable Type

Symbol

2 position single

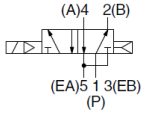

2 position single with back pressure check valve

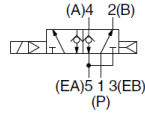

2 position double

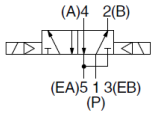

2 position double with back pressure check valve

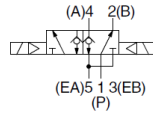

3 position closed center

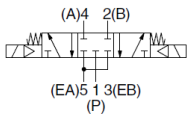

3 position exhaust center

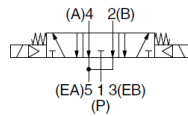

3 position pressure center

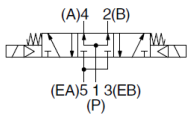

2 position single

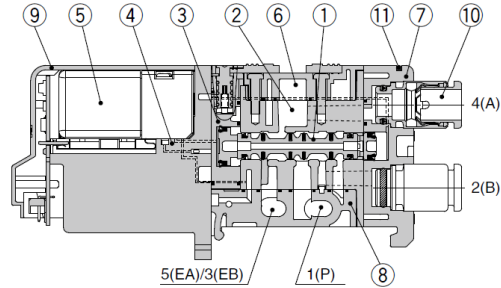

2 position double

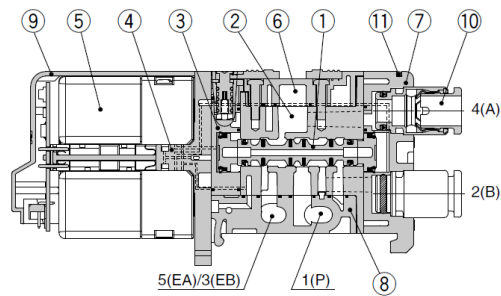

3 position closed center/exhaust center/pressure center

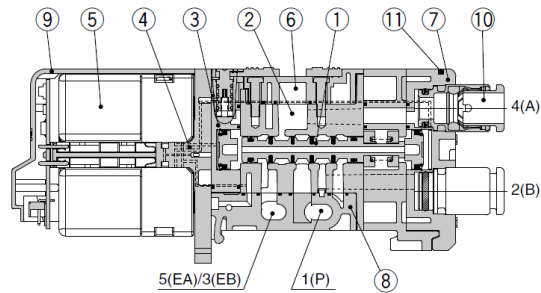

Component Parts

No.	Description	Material	Note
1	Spool valve assembly	Resin/HNBR (3 position solenoid valve: Aluminum/HNBR)	—
2	Body	Zinc die-cast	—
3	Adapter plate	Resin	White
4	Pilot adapter	Resin	White
5	Pilot valve assembly	—	—
6	Body cover	Resin	White
7	Port block	Resin	White
8	Bottom cover assembly	Resin	White
9	Light cover	Resin	Light blue

Replacement Parts

No.	Description	Part no.
10	One-touch fitting	Refer to the One-touch fitting part no. on page 11.
11	Clip	SJ3000-CL-1 (10 pcs.)

SJ3260K with back pressure check valve

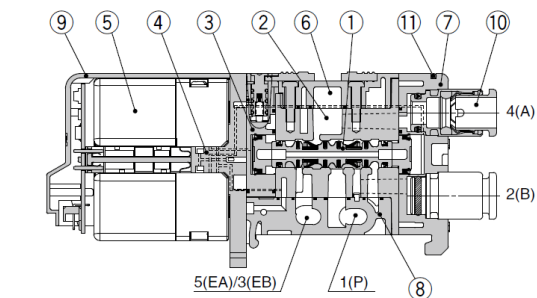

SJ1000/2000/3000 Series Construction 5

SJ3000: Cable Type

Symbol

4 position dual 3 port valve
SJ3A60 [N.C. valve x 2]

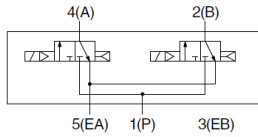

SJ3A60K with back pressure
check valve

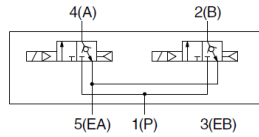

SJ3B60 [N.O. valve x 2]

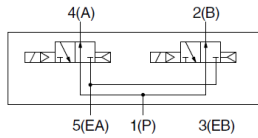

SJ3B60K with back pressure
check valve

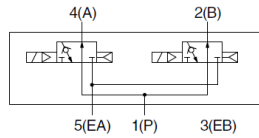

SJ3C60 [N.C., N.O. valve x 1
(each)]

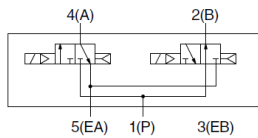

SJ3C60K with back pressure
check valve

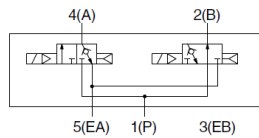

SJ3A60 [N.C. valve x 2]

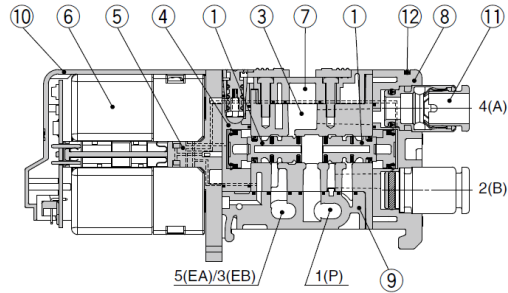

SJ3B60 [N.O. valve x 2]

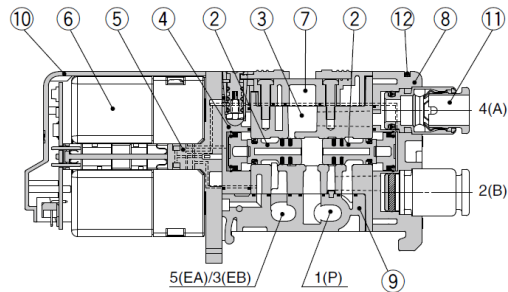

SJ3C60 [N.C. valve, N.O. valve x 1 (each)]

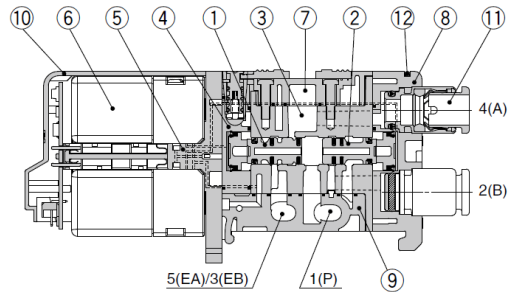

Component Parts

No.	Description	Material	Note
1	Spool valve assembly	Resin/HNBR	N.C. (Normally closed)
2	Spool valve assembly	Resin/HNBR	N.O. (Normally open)
3	Body	Zinc die-cast	—
4	Adapter plate	Resin	White
5	Pilot adapter	Resin	White
6	Pilot valve assembly	—	—
7	Body cover	Resin	White
8	Port block	Resin	White
9	Bottom cover assembly	Resin	White
10	Light cover	Resin	Light blue

Replacement Parts

No.	Description	Part no.
11	One-touch fitting	Refer to the One-touch fitting part no. on page 11.
12	Clip	SJ3000-CL-1 (10 pcs.)

SJ3A60K with back pressure check valve

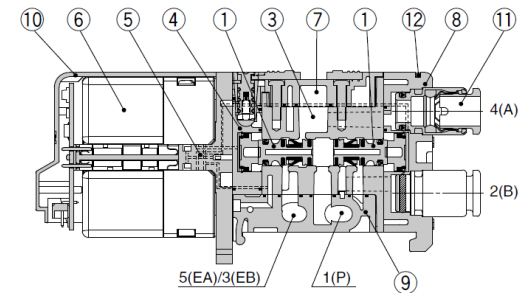

TROUBLESHOOTING

Should any trouble be found during operation, trace the source of the trouble in the following order and take corrective action.

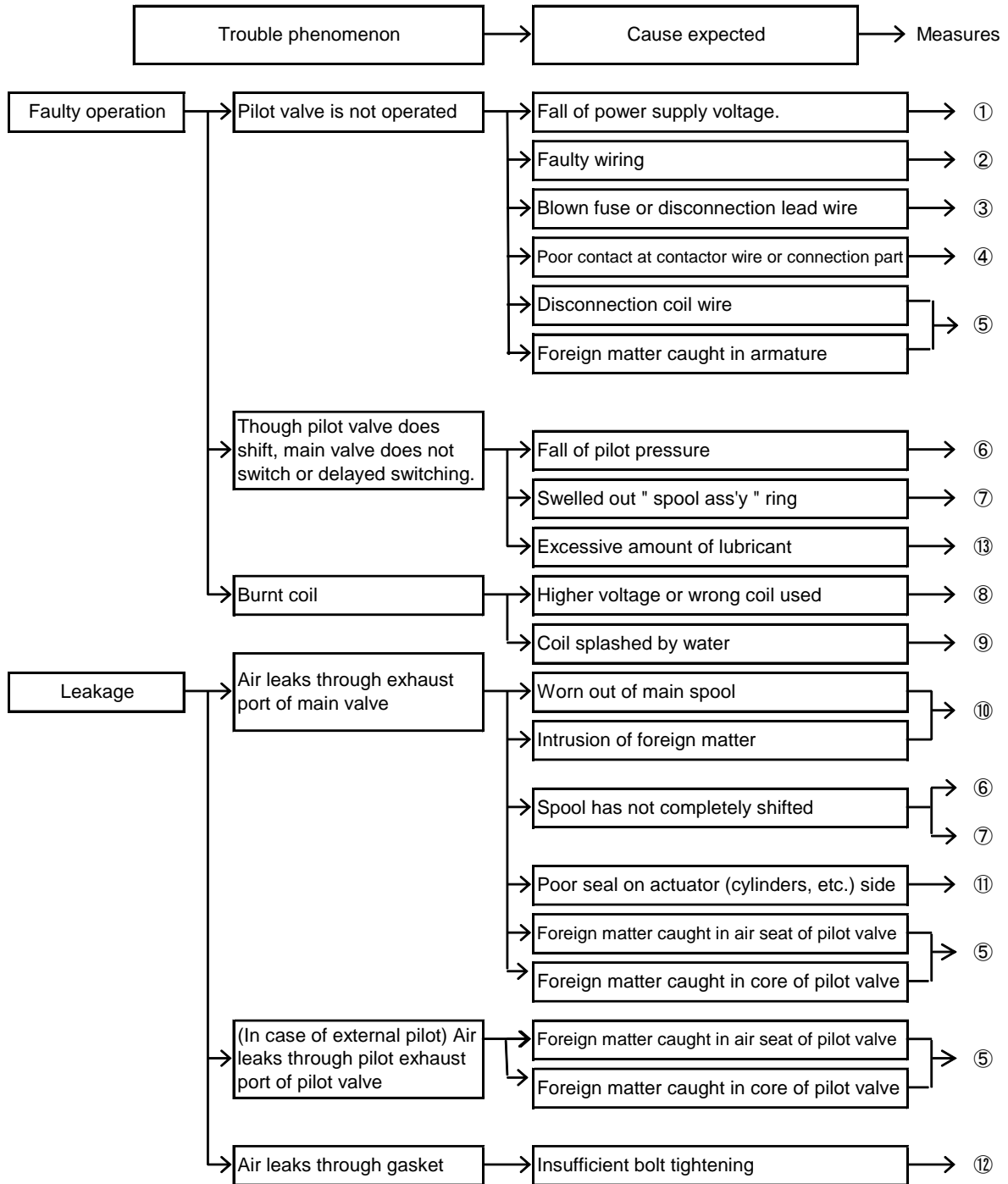

Remedy

No.	Remedy
①	Regulate voltage, so that the voltage at the time of the operation becomes specifications range.
②	Re-wire correctly.
③	Replace part.
④	Replace part or re-wire positively.
⑤	Replace valve.
⑥	Regulate pressure so that pilot pressure will fall within operating pressure range during operation.
⑦	· If wrong oil is used, completely air blow to remove oil, and replace valve. After valve is replaced, use turbine oil class 1 (ISO VG32). · When a large quantity of drain is given and cannot carry out drain omission surely, install either an auto-drain or a dryer. The valve should be replaced.
⑧	Check voltage. Replace valve (pilot valve).
⑨	Protect the valve so that water does not splash the coil.
⑩	In case of intrusion of foreign matter, to remove foreign matter by air blow of piping and then replace valve.
⑪	Repair or replace actuators.
⑫	After stopping air and re-tighten the bolts.
⑬	Reduce the amount of lubricant to the degree that no oil splashes out of the air exhaust (E) port.

If any of followings are carried out, inside of the valve may have some failure. In this case, stop using the valve immediately.

- ① Voltage out of rated voltage has been used.
- ② Oil other than the specified one has been lubricated.
- ③ Lubrication has been stopped intermediately, or lubrication was suspended temporary.
- ④ Water splashed directly. (Except IP65/67 protected product.)
- ⑤ Strong impact was given.
- ⑥ Alien substance such as drain and particle got into. Drain or garbage invaded a valve.
- ⑦ Prohibited way of using the valve which is written at "Precautions" section in this operation manual was carried out excluding above-mentioned.

In addition, in the case of trouble, please send it back to the supplier for repair or replacement.

Revision history	
RENEWAL	2020.7

SMC Corporation

4-14-1, Sotokanda, Chiyoda-ku, Tokyo 101-0021 JAPAN
Tel: + 81 3 5207 8249 Fax: +81 3 5298 5362
URL <https://www.smcworld.com>

Note: Specifications are subject to change without prior notice and any obligation on the part of the manufacturer.
© 2020 SMC Corporation All Rights Reserved