



# Operation Manual

High Vacuum Angle Valve / Straight Valve

PRODUCT NAME

XMC/XYC Series

MODEL/ Series

Thank you for purchasing SMC product.

For appropriate operation of this product, please read this operation manual thoroughly to understand.

Also, refer to the drawing, product information for structure and specification of this product, Confirm operating environment is within specifications.

Keep this operation manual with care so that it can be used at any time.

Contents of this operation manual is subject to change without notice.

## SMC Corporation

# Contents

Safety Instructions	-----	2
1. Product Specific Precautions 1 (Precautions on Design, Selection, Mounting, Piping, Maintenance)	-----	4
2. Product Specific Precautions 2 (Maintenance parts)	-----	6
3. Specifications	-----	7
4. Construction / Dimensions	-----	8
5. Warranty period and guaranteed range	-----	11
6. Parts replacement procedure	-----	12



# Safety Instructions

These safety instructions are intended to prevent hazardous situations and/or equipment damage. These instructions indicate the level of potential hazard with the labels of “Caution,” “Warning” or “Danger.”

They are all important notes for safety and must be followed in addition to International Standards (ISO/IEC)\*1), and other safety regulations.

- \*1) ISO 4414: Pneumatic fluid power -- General rules relating to systems
- ISO 4413: Hydraulic fluid power -- General rules relating to systems
- IEC 60204-1: Safety of machinery -- Electrical equipment of machines (Part 1: General requirements)
- ISO 10218-1992: Manipulating industrial robots -- Safety



## Caution

**Caution** indicates a hazard with a low level of risk which, if not avoided, could result in minor or moderate injury.



## Warning

**Warning** indicates a hazard with a medium level of risk which, if not avoided, could result in death or serious injury.



## Danger

**Danger** indicates a hazard with a high level of risk which, if not avoided, will result in death or serious injury.

## Warning

### 1. The compatibility of the product is the responsibility of the person who designs the equipment or decides its specifications.

Since the product specified here is used under various operating conditions, its compatibility with specific equipment must be decided by the person who designs the equipment or decides its specifications based on necessary analysis and test results.

The expected performance and safety assurance of the equipment will be the responsibility of the person who has determined its compatibility with the product.

This person should also continuously review all specifications of the product referring to its latest catalog information, with a view to giving due consideration to any possibility of equipment failure when configuring the equipment.

### 2. Only personnel with appropriate training should operate machinery and equipment.

The product specified here may become unsafe if handled incorrectly.

The assembly, operation and maintenance of machines or equipment including our products must be performed by an operator who is appropriately trained and experienced.

### 3. Do not service or attempt to remove product and machinery/equipment until safety is confirmed.

1. The inspection and maintenance of machinery/equipment should only be performed after measures to prevent falling or runaway of the driven objects have been confirmed.

2. When the product is to be removed, confirm that the safety measures as mentioned above are implemented and the power from any appropriate source is cut, and read and understand the specific product precautions of all relevant products carefully.

3. Before machinery/equipment is restarted, take measures to prevent unexpected operation and malfunction.

### 4. Contact SMC beforehand and take special consideration of safety measures if the product is to be used in any of the following conditions.

1. Conditions and environments outside of the given specifications, or use outdoors or in a place exposed to direct sunlight.

2. Installation on equipment in conjunction with atomic energy, railways, air navigation, space, shipping, vehicles, military, medical treatment, combustion and recreation, or equipment in contact with food and beverages, emergency stop circuits, clutch and brake circuits in press applications, safety equipment or other applications unsuitable for the standard specifications described in the product catalog.

3. An application which could have negative effects on people, property, or animals requiring special safety analysis.

4. Use in an interlock circuit, which requires the provision of double interlock for possible failure by using a mechanical protective function, and periodical checks to confirm proper operation.



# Safety Instructions

## Caution

### **1.The product is provided for use in manufacturing industries.**

The product herein described is basically provided for peaceful use in manufacturing industries. If considering using the product in other industries, consult SMC beforehand and exchange specifications or a contract if necessary. If anything is unclear, contact your nearest sales branch.

## **Limited warranty and Disclaimer/Compliance Requirements**

The product used is subject to the following “Limited warranty and Disclaimer” and “Compliance Requirements”.

Read and accept them before using the product.

### **Limited warranty and Disclaimer**

**1.The warranty period of the product is 1 year in service or 1.5 years after the product is delivered, whichever is first.\*2)**  
Also, the product may have specified durability, running distance or replacement parts. Please consult your nearest sales branch.

**2.For any failure or damage reported within the warranty period which is clearly our responsibility, a replacement product or necessary parts will be provided.**  
This limited warranty applies only to our product independently, and not to any other damage incurred due to the failure of the product.

**3.Prior to using SMC products, please read and understand the warranty terms and disclaimers noted in the specified catalog for the particular products.**

**\*2) Vacuum pads are excluded from this 1 year warranty.**

A vacuum pad is a consumable part, so it is warranted for a year after it is delivered.

Also, even within the warranty period, the wear of a product due to the use of the vacuum pad or failure due to the deterioration of rubber material are not covered by the limited warranty.

### **Compliance Requirements**

**1.The use of SMC products with production equipment for the manufacture of weapons of mass destruction(WMD) or any other weapon is strictly prohibited.**

**2. The exports of SMC products or technology from one country to another are governed by the relevant security laws and regulation of the countries involved in the transaction. Prior to the shipment of a SMC product to another country, assure that all local rules governing that export are known and followed.**

# 1. Product Specific Precautions 1



## Common Specific Precautions 1

Be sure to read before handling.

### Precautions on Design



#### Warning

- All models

1. The body material is SCS13, the bellows is SUS316L, and other metal seal material is SUS304. Standard seal material in the vacuum section is FKM that can be changed to the other materials (please refer "How to Order"). Use fluids that are compatible with using materials after confirming. Check material to select appropriate fluid.

The seal to attach the vacuum part of XMC-80,XYC-80 uses vacuum grease (Fluorine grease: Y-VAC2).

2. Select materials for the actuation pressure piping, and heat resistance for fittings that are suitable for the applicable operating temperatures.

- Models with auto switch

1. The switch section should be kept at the temperature no greater than 60 °C.

### Selection



#### Caution

- All models

1. When controlling valve responsiveness, take note of the size and length of piping, as well as the flow rate characteristics of the actuating solenoid valve.

2. Pilot pressure should be kept within the specified range.

0.3MPa to 0.5MPa is recommended for XMC/XYC-16, XMC/XYC-25, XMC/XYC-40.

0.4MPa to 0.5MPa is recommended for XMC/XYC-50, XMC/XYC-63, XMC/XYC-80.

3. Use within the limits of the operating pressure range.

- High temperature types

1. In the case of gases which cause a large amount of deposits, heat the valve body to prevent deposits in the valve.

### Mounting



#### Caution

- All models

1. In high humidity environments, keep valves packed until the time of installation.

2. In case with switches, secure the lead wires so that they have sufficient slack, without any unreasonable force applied to them.

3. Perform piping so that excessive force is not applied to the flange sections. In case there is vibration of heavy objects or attachments, secure them so that torque is not applied directly to the flanges.

4. Vibration resistance allows for normal operation of up to 30 m/s<sup>2</sup> (45 to 250Hz), but continuous vibration may cause a decline in durability.

Arrange piping to avoid excessive vibration or impacts.

- High temperature types; (Temperature specifications/H0)

1. When a valve is to be heated, only the body section should be heated, excluding the bonnet section.

## Piping



### Caution

1. Before mounting, clean the surface of the flange seal and the O-ring with ethanol, etc.
2. There is an indentation of 0.1 to 0.2mm in order to protect the flange seal surface, and it should be handled so that the seal surface is not damaged in any way.

## Maintenance



### Warning

If the fluid or reaction product (deposit) may cause the valve to become unsafe, the valve should be disassembled, cleaned and re-assembled by an operator who has sufficient knowledge and experience (e.g. a specialist).



### Caution

1. When removing deposits from the a valve, take care not to damage any part of its parts.
2. Replace the bonnet assembly and the O-ring when the end of its service life is approached.  
\* For details regarding endurance cycles, please reference Section 5 of this Operation manual titled Period and scope of warranty . (pages 11)
3. If damage is suspected prior to the end of the service life, perform early maintenance.
4. SMC specified parts should be used for service. Refer to the Construction / Maintenance parts table.
5. When removing the valve seal and external seal, take care not to damage the sealing surfaces. When installing the valve seal and external seal, be sure that the O-ring is not twisted. (Refer to Section 6 Parts Replacement Procedure (pages 12 to 15) for details.)

## 2. Product Specific Precautions 2



### Common Specific Precautions 2

Be sure to read before handling

Maintenance Parts



### Caution

Only SMC specified parts should be used. Please refer to operation manual.

The bonnet assembly should also be replaced when changing the seal material. Due to the different materials used, changing only the seal may prove inadequate.

#### Bonnet assembly/construction part number:1

Temperature specifications	Valve size			
	16	25	40	50
General use	XLC16-30-1	XLC25-30-1	XLC40-30-1	XLC50-30-1-1
High temperature	XLC16-30-1H	XLC25-30-1H	XLC40-30-1H	XLC50-30-1H-1

Temperature specifications	Valve size	
	63	80
General use	XLC63-30-1-1	XLC80-30-1-1
High temperature	XLC63-30-1H-1	XLC80-30-1H-1

Note1) The magnet for auto switch is not provided. When the magnet for auto switch is necessary, add "-M9//" at the suffix of the part number.(Not available for high temperature models)

Note2) An auto switch for high temperature is available with a different part number.

Note3) List the optional seal material symbol after the model number, except for the standard seal material (FKM: compound No. 1349-80).

Note4) The bonnet assembly includes the valve seal.

#### External seal, valve seal

Description Constructions No.	Material	Valve size			
		16	25	40	50
External seal 3	Standard	AS568-025V	AS568-030V	AS568-035V	AS568-039V
	Specific	AS568-025 **	AS568-030 **	AS568-035 **	AS568-039 **
Valve seal 2	Standard	B2401-V15V	B2401-V24V	B2401-P42V	AS568-227V
	Specific	B2401-V15 **	B2401-V24 **	B2401-P42 **	AS568-227 **

Description Construction No.	Material	Valve size	
		63	80
External seal 3	Standard	AS568-043V	AS568-045V
	Specific	AS568-043 **	AS568-045 **
Valve seal 2	Standard	AS568-233V	B2401-V85V
	Specific	AS568-233 **	B2401-V85 **

Note1) List the optional seal material symbol after the model number, except for the standard seal material (FKM: compound no. 1349-80).

Note2) Refer to the Construction on the page 8 for the construction numbers.

Note3) Please contact SMC if you would like to change the material of the valve seal from ULTIC ARMOR to another material, or from another material to ULTIC ARMOR..

### Optional seal material

Seal material	EPDM (Note 3)	Barrel Perfluoro®	Kalrez®	Chemraz®			VMQ (Note 3)	FKM for PLASMA (Note 3)	ULTIC ARMOR®
Compound No.	2101-80.	70W	4079	SS592	SS630	SSE38	1232-70.	3310-75.	UA4640
Symbol	<b>-XN1</b>	<b>-XP1</b>	<b>-XQ1</b>	<b>-XR1</b>	<b>-XR2</b>	<b>-XR3</b>	<b>-XS1</b>	<b>-XT1</b>	<b>-XU1</b>

Note1) Due to the different materials used, changing only the seal may prove inadequate.

Note2) Barrel Perfluoro® is a registered trademark of MATSUMURA OIL Co.,Ltd.

Kalrez® is a registered trademark of Dupont Co.,Ltd.

Chemraz® is a registered trademark of Greene, Tweed & Co.,

ULTIC ARMOR® is a registered trademark of NIPPON VALQUA INDUSTRIES, LTD.

Note3) MITSUBISHI CABLE INDUSTRIES, LTD.

## 3. Specifications

Model Note 1		XMC-16	XMC-25 XYC-25	XMC-40 XYC-40	XMC-50 XYC-50	XMC-63 XYC-63	XMC-80 XYC-80	
Flange (valve) size		16,CF034	25	40,CF070	50	63,CF114	80	
Actuating type	Double acting(Dual operation) , pressurize to open/close							
Fluid	Inactive gas under vacuum							
Operating temperature °C	5 to 60 (High temperature type:5 to 150)							
Operating pressure Pa (abs)	Atmospheric pressure to $1 \times 10^{-6}$							
Conductance l/s Note 2		5	14	45	80	160	200	
Leakage Pa m <sup>3</sup> /s	Internal	$1.3 \times 10^{-10}$ for the standard material (FKM) at ambient temperatures , excluding gas permeation						
	External	$1.3 \times 10^{-11}$ for the standard material (FKM) at ambient temperatures , excluding gas permeation						
Flange type	XMC	KF(NW),CF	KF(NW)	KF(NW),CF	KF(NW)	KF(NW),K(DN) ,CF	KF(NW),K(DN)	
	XYC	-	KF(NW)	KF(NW)	KF(NW)	KF(NW) K(DN)	KF(NW) K(DN)	
Main material	Body: SCS13(Stainless) Bellows: SUS316L, Main part: SUS304 and FKM (standard sealing material)							
Actuation pressure MPa (G)	0.3 to 0.6				0.4 to 0.6			
Air consumption cm <sup>3</sup> Note 3	At 0.5MPa	38	91	430	280	500	1000	
Port size	M5			Rc 1/8				
Mass Note 4	kg	XMC	0.36 (0.40)	0.62	1.40(1.76)	2.10	3.80 (5.16)	6.30
		XYC	-	0.67	1.42	2.50	4.50	7.80

Note1) XYC-16 is not available. (Interference due to the flange shape)

Note2) The conductance is "molecular flow" measured with an elbow pipe which has the same dimension with each flange.

Note3) Air consumed by a reciprocating motion of a cylinder.

Note4) Figures in ( ) indicates the mass of CF (conflate) fittings.



## 4. Construction / Dimensions

### 4-1. Construction

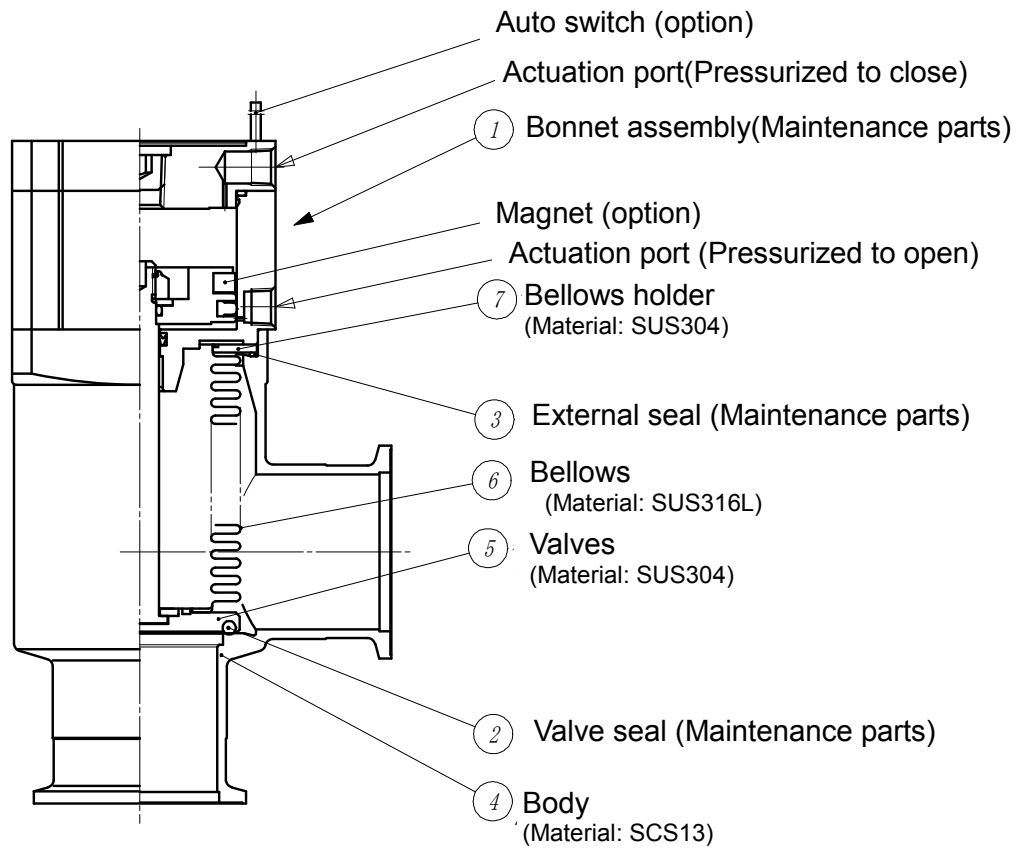

XMC series / Angled Valve

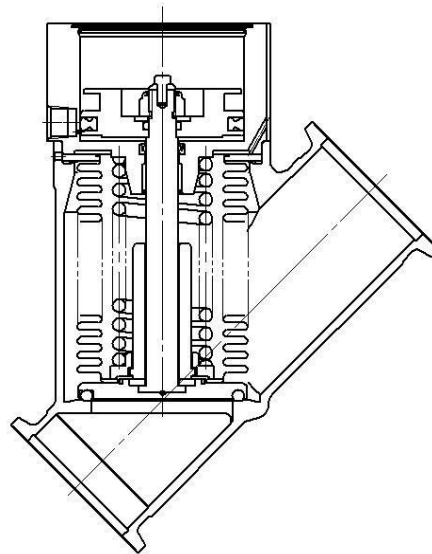

XYC series / Straight Valve

Construction of XMC series and XYC series are the same except the Body shape.

## 4-2. XMC Exterior dimensions

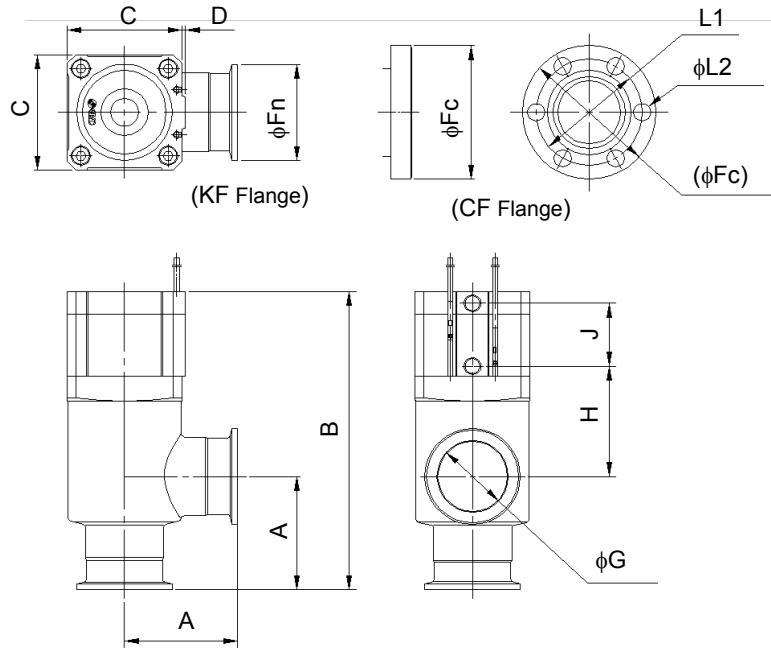

Unit:mm

Model	A	B	C	D	Fn	Fc	G	H	J	P.C.D L1	L2
XMC-16	40	110	38	1	30	34	17	40	26	P.C.D 27	6xφ4.4
XMC-25	50	120	48	1	40	-	26	39	28	-	-
XMC-40	65	171	66	2	55	70	41	63	36	P.C.D. 58.7	6xφ6.6

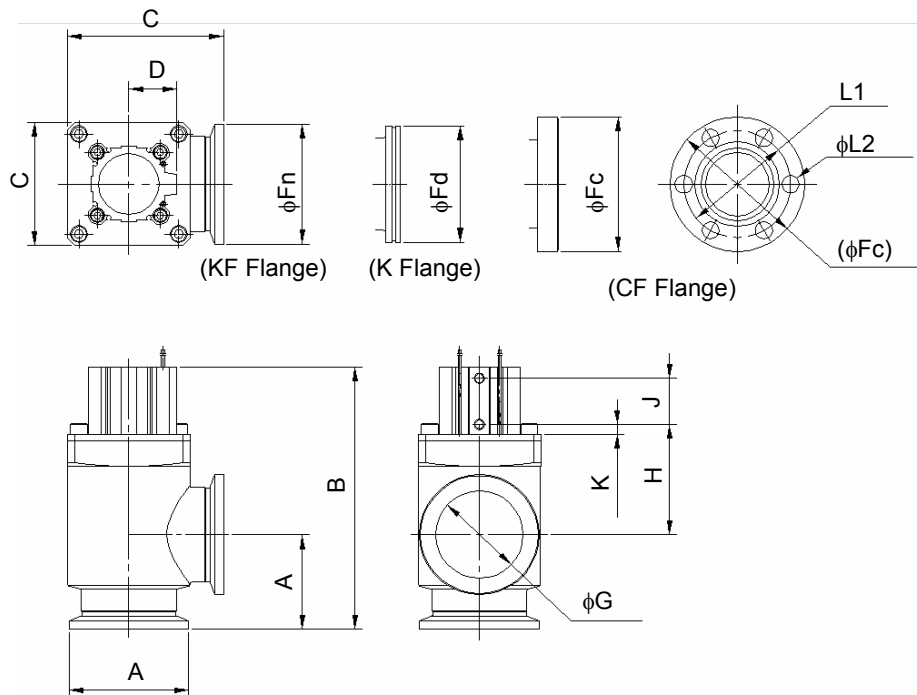

Unit:mm

Model	A	B	C	D	Fn	Fc	Fd	G	H	J	K	P.C.D L1	L2
XMC-50	70	183	80	31	75	-	-	52	77	29	10.5	-	-
XMC-63	88	209	100	39	87	114	95	70	76.5	36	9	P.C.D 92.1	8xφ8.4
XMC-80	90	250	117	45.5	114	-	110	83	105	44	9	-	-

### 4-3. XYC Exterior dimensions

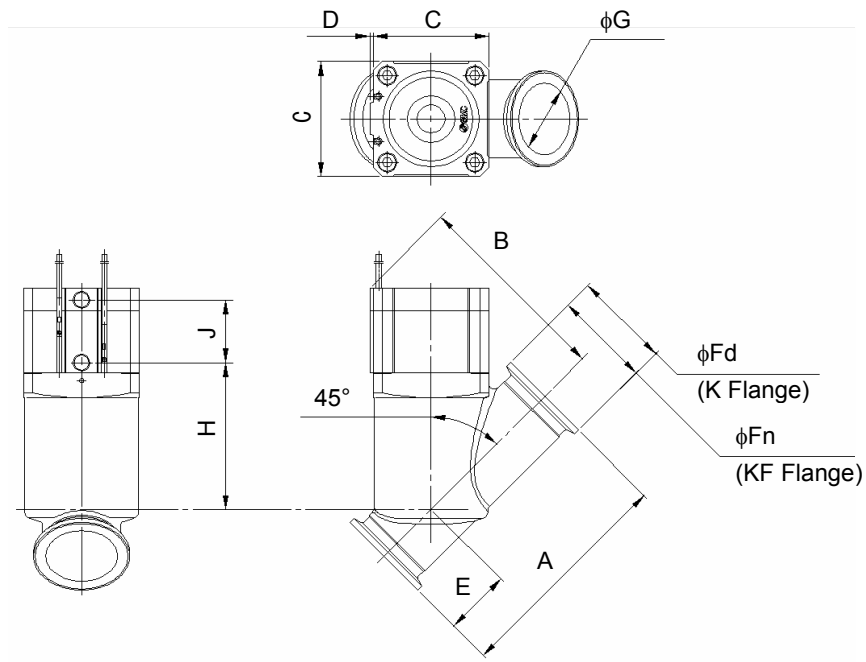

Unit:mm

Model	A	B	C	D	E	Fn	Fd	G	H	J
XYC-25	100.2	85	48	1	23.5	40	-	26	64	28
XYC-40	130	115	66	2	38	55	-	41	84	36

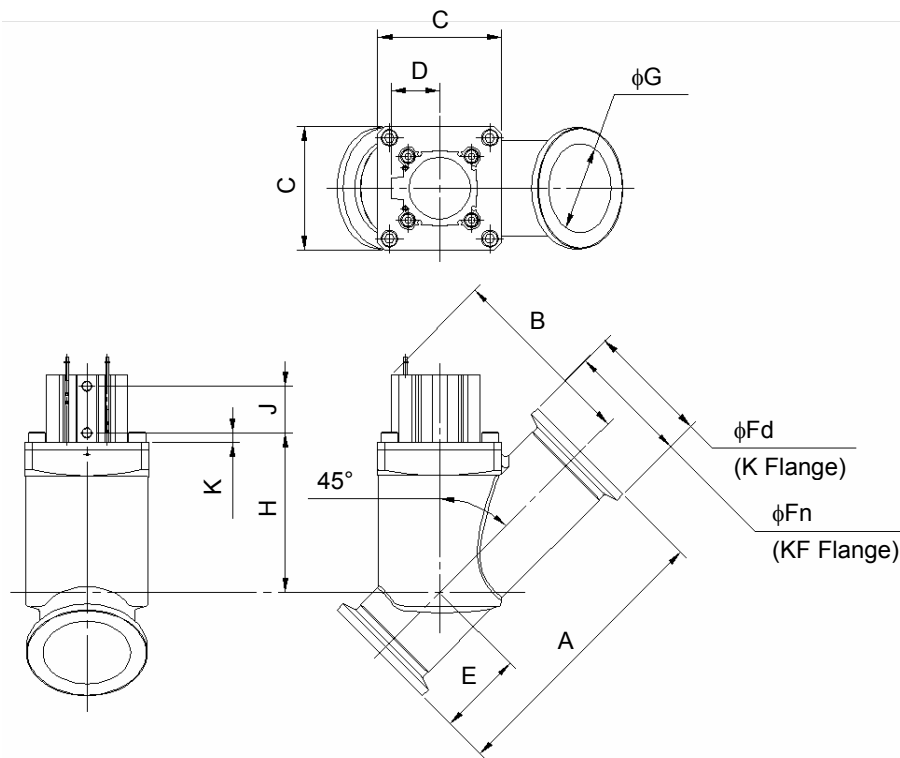

Unit:mm

Model	A	B	C	D	E	Fn	Fd	G	H	J	K
XYC-50	178	121	80	31	53	75	-	52	104	29	10.5
XYC-63	209	148	100	39	61	87	95	70	126	36	9
XYC-80	268	177	117	45.5	80	114	110	83	105	44	9

## 5. Warranty period and guaranteed range

The guaranteed period covers the period which finishes the earliest among 2 million operating cycles [with our durability test conditions], 18 months after shipping from us, and 12 months after starting the use of the product at your place or your customer's place.

If the specification is not kept, or any non-conformance derived from mounting or replace of a device, an assembly, or an O-ring at your place occurs, the guarantee cannot be applied.

Note: The product durability is varied depending on the operating conditions (such as a use with large flow rate).

If any failure occurs due to our fault during the guaranteed period, we will guarantee the non-conformance by delivering a substitute in the worst case. However, responsibility of any damage which is led by the product failure is not taken by us.

Result of durability test (with the circuit shown on the right)

Internal/ external leakage and operation were checked by opening and closing a valve in internally evacuated condition at ordinary temperature (room temperature).

It was confirmed that this product satisfied the specification up to 2 million cycles.

The test was performed with FKM, the standard sealing material.

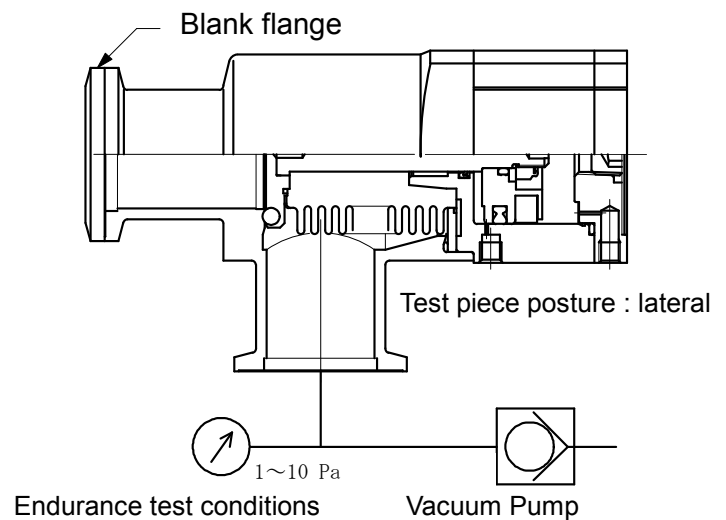

### <Reference>

The pumping direction is not limited, but if the pumping creates a flow stream, the durability of the product could be impaired.

Therefore, the pumping direction shown on the right figure (bellows side pumping) is recommended. Also, the operating conditions should be checked beforehand because it affects the life.

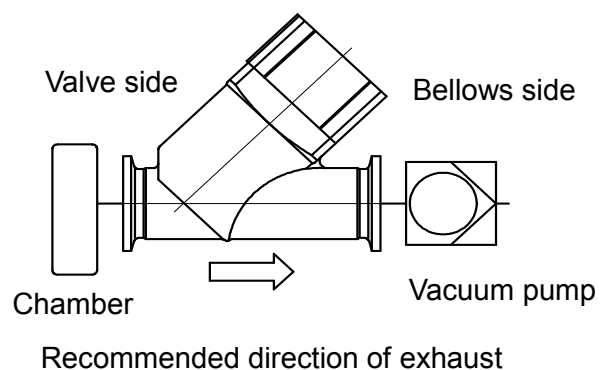
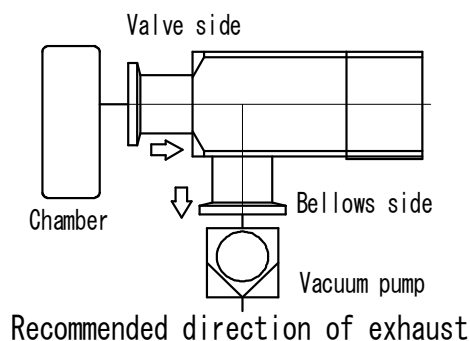

## 6. Parts replacement procedure

### 6-1. Precautions

Be sure to follow [1. Precautions 1] when disassembling the product for maintenance. Along with the precautions above, comply with the following precautions too.

#### **Warning**

- If it is expected that product materials may get stuck to the product, ensure safety is assured before handling. It is recommended to wear gloves and a mask.
- Pay attention to the handling of components according to the procedure in the next item onwards. Do not apply excessive force or impact. This will not only damage the product but also decrease its performance and life expectancy.
- It is not possible to disassemble the bonnet assembly of this product. If the components and assembly are damaged, or damage is expected, exchange the bonnet assembly itself.
- Do not disassemble the parts that are not explained in this operation manual. The performance and life may decrease. Also, it may cause danger.

## 6-2. Disassembly procedure

### Step 1

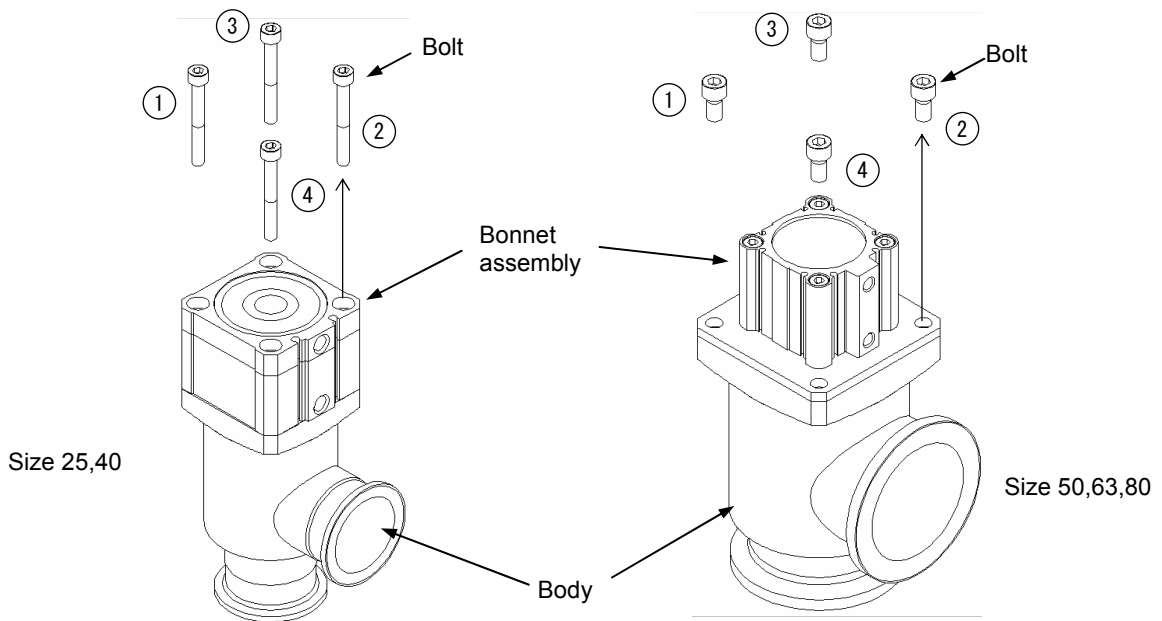

Disassemble the Body and the Bonnet assembly by gradually loosening the hexagon socket head cap screws.

Note) When the valve size is over 50, be careful with the location of the hexagon socket head cap screws to be removed. (Those mounted outermost should be removed.)

### Step 2

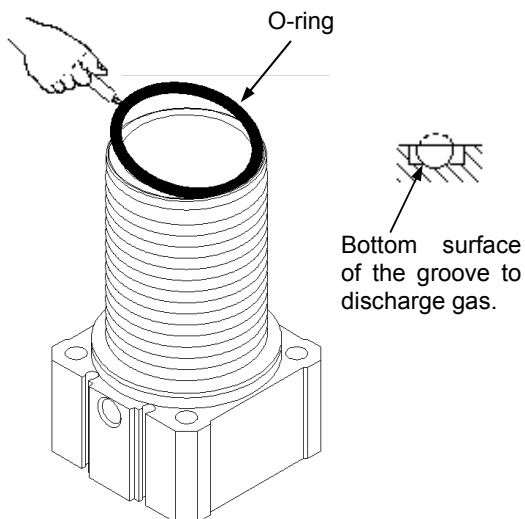

Remove the O ring from the groove for discharging gas using a tool (plastic) whose height is the same as the groove for discharging gas. <Take care not to damage the O ring groove>

### Step 3

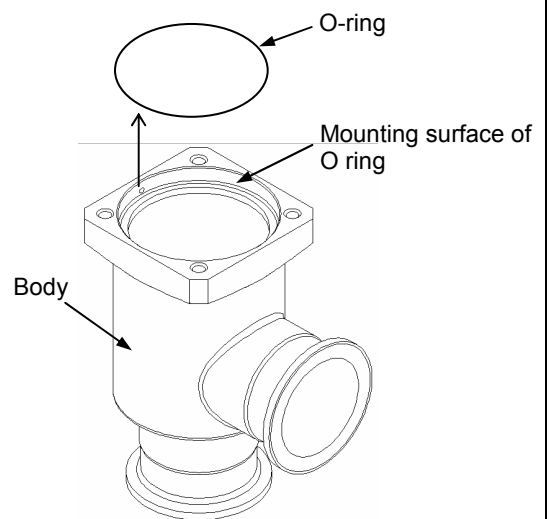

Remove the external seal O ring from the body  
<Take care to prevent the mounting surface of O ring from being damaged>

## 6-3. Assembly Procedure

### Step 1

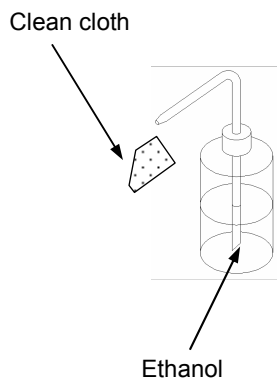

Assemble parts eliminating dust. Wipe off dust with a clean cloth soaked with ethanol. Blow parts with clean air if necessary. <Ensure there is no fiber or dust>

### Step 2

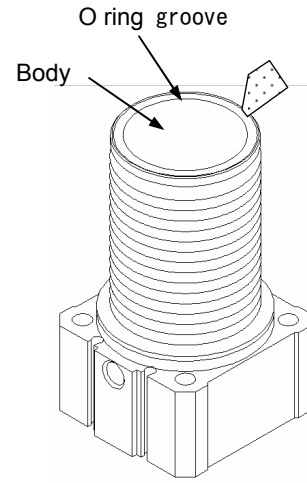

Eliminate the dust of O ring groove of pilot valve.

### Step 3

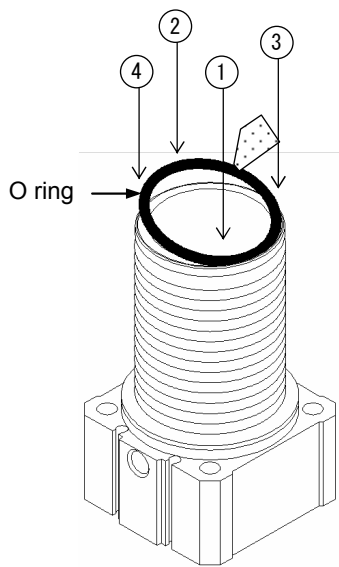

Wipe off the dust on the valve seal O ring surface. Place the O ring on the O ring groove. Press the O-ring into the groove in numerical order (press diagonally) to fit the O-ring into the groove. Take care not to twist the O ring.  
<Use dust-free gloves>

### Step 4

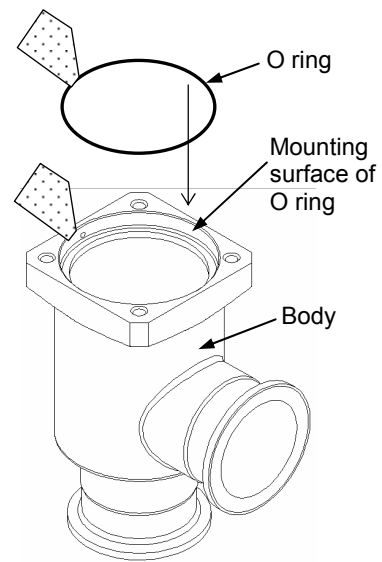

Wipe off the dust from the external seal O ring surface and the mounting surface of the body O ring. Place the O ring on the O ring mounting surface.

### Step 5

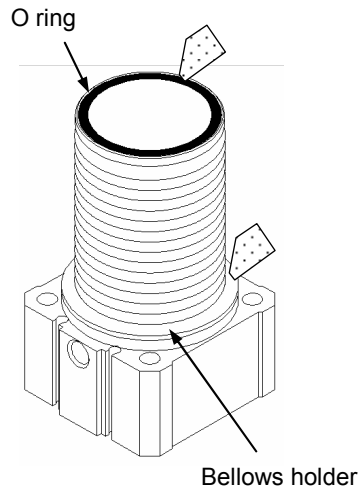

Wipe off any dust from the valve seal O-ring and the bellows holder surface.

### Step 6

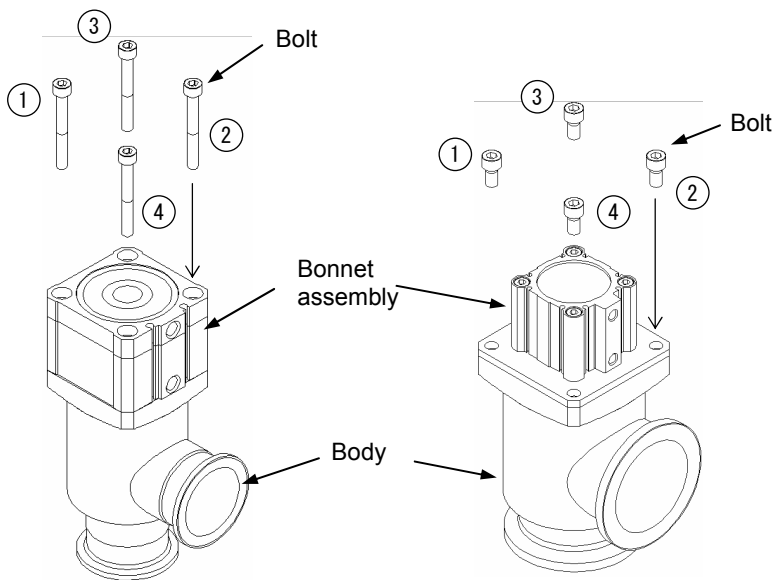

Tightening torque  
N · m

Valves Size	Tightening Torque
X*C-25	1.5
-40	2.5
-50	6
-63	6
-80	15

Assemble Body and Bonnet assembly by tightening the bolt in numerical order. Manually tighten bolts until O-ring is compressed. Perform final torque with same numerical order.



Revision history

A	Limited warranty and Disclaimer	Ro
---	---------------------------------	----

1st Printing :PU

## SMC Corporation

4-14-1, Sotokanda, Chiyoda-ku, Tokyo 101-0021 JAPAN  
Tel: + 81 3 5207 8249 Fax: +81 3 5298 5362  
URL <http://www.smcworld.com>

---

Note: Specifications are subject to change without prior notice and any obligation on the part of the manufacturer.  
© 2012 SMC Corporation All Rights Reserved