



Operation Manual

PRODUCT NAME

***Vacuum Unit
Ejector / Vacuum Pump System***

MODEL / Series / Product Number

ZK2*A Series

SMC Corporation

Contents

Safety Instructions	2
1. How to Order	9
2. Summary of Product Parts	14
3. Installation	16
3.1. Installation	16
3.2. Air Supply	18
3.3. Piping	19
4. Solenoid Valve	23
5. Pressure Sensor/Pressure Switch	30
6. Construction/Replacement Parts	31
6.1. Construction for Single Unit	31
6.2. Component Parts	31
6.3. Replacement Parts	32
6.4. Replacement Parts for Single Unit/How to Order	33
7. Exploded View of Manifold/Replacement Parts	37
7.1. Exploded View of Manifold	37
7.2. How to Increase Manifold Stations	38
7.3. Component Parts	40
7.4. Replacement Parts	41
7.5. Replacement Parts for Manifold/How to Order	41
8. Maintenance	48
8.1. Maintenance	48
8.2. Replacement Procedure	50
9. Specifications	55
10. Port Layout	60
11. Exhaust/Flow Rate Characteristics	70
11.1. Ejector Exhaust Characteristics/Flow Rate Characteristics	70
11.2. Vacuum Pump System Flow Rate Characteristics	72
11.3. Vacuum Release Flow Rate Characteristics	72
12. Limitations of Use	74
13. Troubleshooting	76



Safety Instructions

These safety instructions are intended to prevent hazardous situations and/or equipment damage. These instructions indicate the level of potential hazard with the labels of "Caution," "Warning" or "Danger." They are all important notes for safety and must be followed in addition to International Standards (ISO/IEC)*1), and other safety regulations.

*1) ISO 4414: Pneumatic fluid power -- General rules relating to systems.
ISO 4413: Hydraulic fluid power -- General rules relating to systems.
IEC 60204-1: Safety of machinery -- Electrical equipment of machines .(Part 1: General requirements)
ISO 10218: Manipulating industrial robots -Safety.
etc.



Caution

Caution indicates a hazard with a low level of risk which, if not avoided, could result in minor or moderate injury.



Warning

Warning indicates a hazard with a medium level of risk which, if not avoided, could result in death or serious injury.



Danger

Danger indicates a hazard with a high level of risk which, if not avoided, will result in death or serious injury.

Warning

1. The compatibility of the product is the responsibility of the person who designs the equipment or decides its specifications.

Since the product specified here is used under various operating conditions, its compatibility with specific equipment must be decided by the person who designs the equipment or decides its specifications based on necessary analysis and test results.

The expected performance and safety assurance of the equipment will be the responsibility of the person who has determined its compatibility with the product.

This person should also continuously review all specifications of the product referring to its latest catalog information, with a view to giving due consideration to any possibility of equipment failure when configuring the equipment.

2. Only personnel with appropriate training should operate machinery and equipment.

The product specified here may become unsafe if handled incorrectly.

The assembly, operation and maintenance of machines or equipment including our products must be performed by an operator who is appropriately trained and experienced.

3. Do not service or attempt to remove product and machinery/equipment until safety is confirmed.

1. The inspection and maintenance of machinery/equipment should only be performed after measures to prevent falling or runaway of the driven objects have been confirmed.
2. When the product is to be removed, confirm that the safety measures as mentioned above are implemented and the power from any appropriate source is cut, and read and understand the specific product precautions of all relevant products carefully.
3. Before machinery/equipment is restarted, take measures to prevent unexpected operation and malfunction.

4. Contact SMC beforehand and take special consideration of safety measures if the product is to be used in any of the following conditions.

1. Conditions and environments outside of the given specifications, or use outdoors or in a place exposed to direct sunlight.
2. Installation on equipment in conjunction with atomic energy, railways, air navigation, space, shipping, vehicles, military, medical treatment, combustion and recreation, or equipment in contact with food and beverages, emergency stop circuits, clutch and brake circuits in press applications, safety equipment or other applications unsuitable for the standard specifications described in the product catalog.
3. An application which could have negative effects on people, property, or animals requiring special safety analysis.
4. Use in an interlock circuit, which requires the provision of double interlock for possible failure by using a mechanical protective function, and periodical checks to confirm proper operation.



Safety Instructions

Caution

1. The product is provided for use in manufacturing industries.

The product herein described is basically provided for peaceful use in manufacturing industries. If considering using the product in other industries, consult SMC beforehand and exchange specifications or a contract if necessary.
If anything is unclear, contact your nearest sales branch.

Limited warranty and Disclaimer/Compliance Requirements

The product used is subject to the following “Limited warranty and Disclaimer” and “Compliance Requirements”. Read and accept them before using the product.

Limited warranty and Disclaimer

1. The warranty period of the product is 1 year in service or 1.5 years after the product is delivered, whichever is first.*2)

Also, the product may have specified durability, running distance or replacement parts. Please consult your nearest sales branch.

2. For any failure or damage reported within the warranty period which is clearly our responsibility, a replacement product or necessary parts will be provided.

This limited warranty applies only to our product independently, and not to any other damage incurred due to the failure of the product.

3. Prior to using SMC products, please read and understand the warranty terms and disclaimers noted in the specified catalog for the particular products.

***2) Vacuum pads are excluded from this 1 year warranty.**

A vacuum pad is a consumable part, so it is warranted for a year after it is delivered.

Also, even within the warranty period, the wear of a product due to the use of the vacuum pad or failure due to the deterioration of rubber material are not covered by the limited warranty.

Compliance Requirements

1. The use of SMC products with production equipment for the manufacture of weapons of mass destruction(WMD) or any other weapon is strictly prohibited.

2. The exports of SMC products or technology from one country to another are governed by the relevant security laws and regulation of the countries involved in the transaction. Prior to the shipment of a SMC product to another country, assure that all local rules governing that export are known and followed.









Caution

SMC products are not intended for use as instruments for legal metrology.



Measurement instruments that SMC manufactures or sells have not been qualified by type approval tests relevant to the metrology (measurement) laws of each country.

Therefore, SMC products cannot be used for business or certification ordained by the metrology (measurement) laws of each country.

Safety Instructions

 Warning	
 Disassembly prohibited	Do not disassemble, modify (including the replacement of board) or repair other than instructed in this manual. Otherwise, an injury or failure can result.
 Do not	Do not operate the product outside of the specifications. Do not use for flammable or harmful fluids. Fire, malfunction, or damage to the product can result. Please check the specifications before use.
 Do not	Do not use in an atmosphere containing flammable or explosive gases. Fire or an explosion can result. The product is not designed to be explosion proof.
 Do not	Do not use the product in a place where static electricity is a problem. Otherwise failure or malfunction of the system can result.
 Do not	Do not cut off the power and compressed air supplied to this product while it is operating. Otherwise it can cause injury due to dropping of workpieces or damage to the system.
 Instruction	If using the product in an interlocking circuit - Provide a double interlocking system, for example a mechanical system. - Check the product for proper operation. Otherwise malfunction can result, causing an accident.
 Instruction	The following instructions must be followed during maintenance - Turn off the power supply - Stop the air supply, exhaust the residual pressure in piping and verify that the air is released before performing maintenance work. It may cause an injury.

⚠ Caution

 Do not touch	<p>Do not touch the terminals and connectors while the power is on.</p> <p>Otherwise electric shock, malfunction or damage to the switch can result.</p>
 Instruction	<p>Perform sufficient trial run.</p> <p>Otherwise, injury or damage to the system can result due to suction failure depending on the conditions of the suction of the workpiece or the pressure switch settings.</p> <p>Perform sufficient verification before using this product.</p>
 Instruction	<p>After maintenance is complete, perform appropriate functional inspections and leak test.</p> <p>Stop operation if the equipment does not function properly or there is leakage of fluid.</p> <p>If there is leakage from parts other than the piping, the product might be broken.</p> <p>Cut off the power supply and stop the fluid supply.</p> <p>Do not supply fluid if there is leakage.</p> <p>Safety cannot be assured in the case of an unexpected malfunction.</p>

■ Handling Precautions

Follow the instructions given below for selecting and handling of the vacuum unit.

- The instructions on design and selection (installation, wiring, environment, adjustment, operation, piping, maintenance, etc.) described below must be followed.

*Product specifications

- It is recommended to use compressed air which purity class is 2:6:3 of ISO8573-1:2010.
If compressed air containing condensate is used, install an air dryer or drain catch before the filter and perform draining regularly.
If draining is not performed regularly and condensate enters the secondary side, it can cause operating failure of pneumatic equipment.
When it is difficult to control drainage, the use of a filter with an auto drain is recommended.
- The applicable fluid is air.
Do not use a fluid containing chemicals, synthetic oils including organic solvent, salt and corrosive gases.
Otherwise, damage to the vacuum unit and malfunction can result.
Check the details of the specifications before use.
- Use the specified operating pressure.
Otherwise it can cause damage to the vacuum unit or inability to adsorb correctly.
The parts around the vacuum port of this product are designed to be used with vacuum pressure. With the vacuum pump system, since air is not released to the atmosphere from a silencer, the applied air for vacuum release increases the internal pressure of the vacuum port. Select the vacuum pad which shape allows smooth exhaust of release air to the atmosphere and avoid clogging.
- Reserve a space for maintenance.
Design the system allowing the required space for maintenance.
- Use the specified voltage.
Otherwise failure or malfunction can result.
- Do not exceed the specified maximum allowable load.
Otherwise it can cause damage or shorten the life of the product.
- Design the product to prevent reverse current when the circuit is opened or the product is forced to operate for operational check.
Reverse current can cause malfunction or damage the product.

●Product handling

* Installation

- Tighten to the specified tightening torque.
If the tightening torque is exceeded, the product, the mounting screws, brackets and the pressure switch can be broken. Insufficient torque can cause displacement of the product and the pressure switch from each proper position and loosening of the mounting screws.
- If a commercially available switching power supply is used, be sure to ground the frame ground (FG) terminal.
- Do not drop, hit or apply excessive shock to the product.
Otherwise damage to the internal parts of the product, solenoid valve and internal parts of the pressure switch/sensor can result, causing malfunction.
- Do not pull the lead wire forcefully, or lift the product by pulling the lead wire.
For tensile strength, refer to the following table.
Hold the product body when handling to prevent damage, failure or malfunction.
The solenoid valve and the pressure switch/sensor will be damaged, leading to failure and malfunction.
- Eliminate any dust left in the piping by using a blast of air before connecting the piping to the product.
It will cause failure or malfunction.
- Do not insert metal wires or other foreign objects into the pressure port of the pressure sensor.
The pressure sensor may get damaged, leading to failure and malfunction.
- If the fluid may contain foreign matter, install and connect a filter or mist separator to the inlet.
It will cause failure or malfunction.

* Wiring (Including connecting/disconnecting of the connectors)

- Do not pull hard on the lead wire, or lift the product by holding the lead wires. In particular, never lift the product by the lead wire of the solenoid valve or the pressure switch/sensor when fittings and piping are built in.
Otherwise damage to the solenoid valve or the internal parts of the pressure switch/sensor can result, causing malfunction or causing the connector to come off.
For tensile strength, refer to the following table.
- Avoid repeatedly bending, stretching or applying a heavy object or force to the lead wire.
Repetitive bending stress or tensile stress to the lead wire can cause the sheath of the wire to peel off.
If the lead wire can move, fix it near the body of the product.
The recommended bend radius of the lead wire is 6 times the outside diameter of the sheath, or 33 times the outside diameter of the insulation material, whichever is larger.
Replace the damaged lead wire with a new one.
- Wire correctly.
Incorrect wiring can cause malfunction or breakage of the solenoid valve or the pressure switch/sensor.
- Do not perform wiring while the power is on.
Otherwise damage to the solenoid valve or the internal parts of the pressure switch/sensor can result, causing malfunction.
- Do not route wires and cables together with power or high voltage cables.
Route the wires (piping) of the solenoid valve or the pressure switch/sensor separately from power or high voltage cables in order to avoid noise or surge entering the signal line from the power or high voltage line.
- Confirm proper insulation of wiring.
Poor insulation (interference with other circuits, poor insulation between terminals etc.) can apply excessive voltage or current to the solenoid valve or the pressure sensor/sensor, causing damage.
- Design the system to prevent reverse current when the product is forced to operate for operational check.
Depending on the circuit used, insulation may not be maintained when operation is forced, allowing reverse current to flow, which can cause malfunction and damage to the solenoid valve or the pressure switch/sensor.
- Keep wiring as short as possible to prevent interference from electromagnetic noise and surge voltage.
Do not use a cable longer than 10 m.
Wire the DC (-) line as close as possible to the power supply.

Tensile strength of each lead wire

Cable type	Tensile strength
Connector Assembly (for solenoid valve)	25N or less
Lead wire with connector for pressure switch for vacuum	35N or less
Lead wire with connector for pressure switch with energy saving function	20N or less
Pressure sensor assembly	50N or less

*Operating environment

- Do not use in an environment where corrosive gases, chemicals, sea water, water or steam are present. These may cause failure or malfunction.
- Do not use the product in a place where the product could be splashed by oil or chemicals. If the product is to be used in an environment containing oils or chemicals such as coolant or cleaning solvent, even for a short time, the solenoid valve or pressure switch/sensor may be adversely affected (damage, malfunction, or hardening of the lead wires).
- Do not use in an area where surges are generated. When there are machines or equipment that generate large surge near the pressure switch/sensor (magnetic type lifter, high frequency inductive furnace, motor, etc.), this can result in deterioration and damage of the internal elements. Take measures against the surge sources, and prevent the lines from coming into close contact.
- Do not use a load which generates surge voltage. When a surge-generating load such as a relay or solenoid is directly driven, use the product with a surge absorbing element built-in.
- The product is CE marked, but not immune to lightning strikes, so take measures against lightning strikes. Be aware of excessive surrounding noise. The product is CE marked and has passed the EMC test, but excessive noises in the surrounding area may affect the functioning of the product.
- Mount the product in a location that is not affected by vibration or impact. It will cause failure or malfunction.
- Do not let foreign matter, such as wire debris, get inside the product. In order to avoid failure and malfunction, do not let foreign matter, such as wire debris, get inside the product.
- Do not use the product in an environment that is exposed to temperature cycle. Heat cycles other than ordinary changes in temperature can adversely affect the inside of the product.
- Do not expose the product to direct sunlight. If using in a location directly exposed to sunlight, protect the product from the sunlight. Failure or malfunction may occur.
- Keep within the specified operating fluid and ambient temperature range. Operation under low temperature may lead to damage or operation failure due to frozen moisture in the fluid or air. Protection against freezing is necessary. Mounting of an air dryer is recommended for elimination of drainage and water. Avoid abrupt temperature changes even within the specified temperature range.
- Do not use in a location where the product is exposed to radiant heat from surrounding heat sources. Insufficient air quality may cause operation failure.

* Adjustment and Operation

- Connect a load before turning the power supply on. If the power supply is turned on with no load, over current may flow, causing the pressure switch/sensor to break instantly.
- Do not short-circuit the load. An error is displayed when the load of the pressure switch/sensor is short circuited, but over current may flow, causing damage to the pressure switch.
- Do not press the setting buttons with a sharp pointed object. This may damage the setting buttons.
- If using the product to detect very small pressures, warm up the product for 10 to 15 minutes first. There will be a drift on the display of approximately 1% for 10 minutes after the power supply is turned on.
- Perform settings suitable for the operating conditions. Incorrect setting can cause operation failure. For details of each setting, refer to the Operation Manual of the pressure switch/sensor.
- Do not touch the LED during operation. The display can vary due to static electricity.

*Piping

- Preparation before piping

Before piping, perform air blow (flushing) or cleaning to remove any cutting chips, cutting oil, dust, etc. from the piping.

- Wrapping of pipe tape

When installing piping or a tube fitting into a port, prevent cutting chips and sealant material from getting inside the product.

If a sealant tape is used, leave 1 thread exposed at the end of threads.

- When connecting tubing, consider factors such as changes in the tubing length due to pressure, and allow a sufficient margin.

Otherwise, it can damage the fitting and cause the tube to come off. Refer to Fittings & Tubing Precautions from 1 to 4 shown in Best Pneumatics 6 on SMC's website (URL <http://www.smcworld.com>) for the recommended piping conditions.

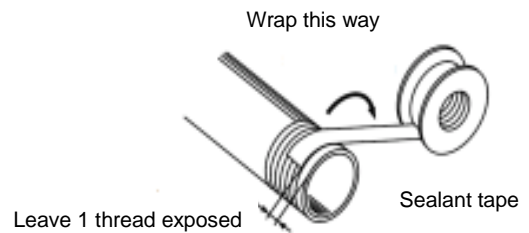

*Maintenance

- Turn off the power supply, stop the supplied air, exhaust the residual compressed air in the piping and verify the release of air before performing maintenance.

There is a risk of unexpected malfunction of component.

- Perform regular maintenance and inspections.

There is a risk of unexpected failure of components due to the malfunction of equipment and machinery.

- Perform draining regularly.

If condensate enters the secondary side, it can cause operating failure of pneumatic equipment.

- Do not use solvents such as benzene, thinner etc. to clean the product.

This may damage the surface of the body or erase the markings on the body.

Use a soft cloth to remove stains. For heavy stains, use a cloth soaked with diluted neutral detergent and fully squeezed, then wipe up the stains again with a dry cloth.

1. How to Order

■ Single Unit

Ejector System

ZK2 **A** **12** **K** **5** **A** **L** **A** - **08** - □

Vacuum Pump System

ZK2 **P** **00** **K** **5** **A** **L** **A** - **08** - □

(1) (2) (3) (4) (5) (6) (7) (8)

Remains blank when no option is selected.

(1) System/Body Type

Symbol	System	Body type	Exhaust type
A	Ejector system	Single unit	Silencer exhaust
B			Port exhaust ^{note 2)}
G			High-noise reduction silencer exhaust
C		For manifold	Complex exhaust ^{note 3)}
F			Individual port exhaust ^{note 2)}
H			High-noise reduction silencer exhaust
P	Vacuum pump system	Single unit ^{Note 1)}	-
Q		For manifold	-

Note 1) PS port size of vacuum pump system: mm: $\varnothing 4$, inch: $\varnothing 5/32$ "

Note 2) Port size of exhaust port: mm: $\varnothing 8$, inch: $\varnothing 5/16$ "

Note 3) The complex exhaust is a combined exhaust method of the common exhaust from the end plate and the direct exhaust from each station.

(2) Nominal Nozzle Size

Symbol	System	Nominal size
07	Ejector system ^{Note 4)}	$\varnothing 0.7$
10		$\varnothing 1.0$
12		$\varnothing 1.2$
15		$\varnothing 1.5$
00	Vacuum pump system	-

Note 4) Standard supply pressure for nozzle size 07 to 12 is 0.35MPa, 15 is 0.4 MPa.

(3) Combination of Supply Valve and Release Valve ^{Note 5, 6)}

Symbol	Supply valve	Release valve
K	N.C.	N.C.
J ^{Note 7)}	N.C.	None
R	Self-holding release valve linked ^{Note 8)}	N.C.
N	None	None

Note 5) Solenoid valve with light/surge voltage suppressor

Note 6) Only non-locking type is available for the manual override for "K, J, R".

Note 7) When "J" is selected for vacuum pump system, install a release valve or vacuum breaker.

Note 8) Supply valve maintains vacuum by energization (20 ms or more). Stopping the vacuum turns on the release valve.

Refer to Self-holding function of supply valve on [page 23](#)

(4) Rated Voltage ^{Note 9)}

Symbol	Voltage
5	24 VDC
6	12 VDC
0	When (3) is "N"

Note 9) Rated voltage for the supply and release valve

(5) Pressure Sensor/Pressure Switch for Vacuum

Symbol	Type	Pressure range [kPa]	Specifications	
P	Pressure sensor ^{Note 10)}	0 to -101	Analog output 1 to 5V	
T		-100 to 100	Analog output 1 to 5V	
A	Pressure switch for vacuum	0 to -101	NPN 2 outputs	Unit selection function ^{Note 12)}
B				SI unit only ^{Note 13)}
C			PNP 2 outputs	Unit selection function ^{Note 12)}
D				SI unit only ^{Note 13)}
E		-100 to 100	NPN 2 outputs	Unit selection function ^{Note 12)}
F				SI unit only ^{Note 13)}
H			PNP 2 outputs	Unit selection function ^{Note 12)}
J				SI unit only ^{Note 13)}
K	Pressure switch for vacuum with energy saving function ^{Note 11)}	-100 to 100	NPN 1 output	Unit selection function ^{Note 12)}
Q				SI unit only ^{Note 13)}
R			PNP 1 output	Unit selection function ^{Note 12)}
S				SI unit only ^{Note 13)}
N	Without pressure sensor and pressure switch for vacuum			

Note 10) When the pressure sensor "P, T" is selected, select "C, L, L1, Y" for (6) Wiring Combinations. Since only grommet type is available for the pressure sensor, sensor without lead wire cannot be selected.

Note 11) When "K, Q, R, S" is selected, select "K" for (3) Combination of Supply Valve and Release Valve, select "W" or "L3" for (6) Wiring Combinations.

Note 12) Unit selection function is not available in Japan due to new measurement law.

Note 13) Fixed unit: kPa

(6) Wiring Combinations

Symbol	For supply valve/release valve		Pressure sensor assembly/Lead wire with connector for pressure switch
	Wiring type	Connector assembly	
C	Common wiring for manifold	None	Lead wire length: 3m (pressure sensor) 2m (pressure switch)
C1			None ^{Note 15)}
L	Individual wiring	Lead wire length: 300mm ^{Note 14)}	Lead wire length: 3m (pressure sensor) 2m (pressure switch)
L1		None	Lead wire length: 3m (pressure sensor) 2m (pressure switch)
L2		Lead wire length: 300mm ^{Note 14)}	None ^{Note 15)}
L3		None	None ^{Note 15)}
W		Lead wire with connector for pressure switch with energy saving function Lead wire length: 2m	
Y	When "N" is selected for (3) (without supply and release valve)		Lead wire length: 3m (pressure sensor) 2m (pressure switch)
Y1			None
N	When "N" is selected for both (3) and (5) (without supply and release valve, without pressure sensor and pressure switch)		

Note 14) Select "L1, L3" when the connector assembly other than standard lead wire length (300mm) is ordered.
(Refer to Connector assembly on [page 33](#))

Note 15) Select when no pressure switch for vacuum, no pressure sensor or pressure switch for vacuum without Lead wire with connector is used.

(7) Vacuum (V) port ^{Note 16)}

Symbol	Standard	Port size
06	Metric size	ø6 One-touch fitting
08		ø8 One-touch fitting
07	Inch size	ø1/4" One-touch fitting
09		ø5/16" One-touch fitting

Note 16) Supply port (PV) size of single unit: ø6 (mm), ø1/4" (inch)

(8) Options ^{Note 17)}

Symbol	Type	Function/Application
Nil	Without option	-
B	With one bracket for mounting a single unit (Mounting screw is attached.)	Use when a single unit is mounted to the floor in an upright position is requested. (When ordering only bracket, refer to page 17.)
C	Vacuum pump system PE port female thread specification(M3) ^{Note 18)}	Use for pilot pressure exhaust piping. (Standard vacuum pump system is released to the atmosphere.) If (3) combination of supply valve and release valve is R, select the option with the relief pressure supply (PD) port . Single unit / Manifold: Option (D) Manifold: Option (P)
D	With individual release pressure supply (PD) port(M3) ^{Note 19)}	Use when supply pressure for vacuum release is individually requested.
E	Vacuum release flow adjusting needle. Driver type long lock nut type	For manifold, vacuum pump system or exhaust port type, tightening work of the needle is improved by lengthened lock nut which tighten the needle.
J	Vacuum break flow adjusting needle Round lock nut type	Thicker than standard hexagon type. More suitable for hand tightening. Round lock nut improves operability when manifold, vacuum pump system, or exhaust port type is used.
K	Vacuum break flow adjusting needle Screwdriver operation type	Slotted type improves fine adjustment performance when manifold, vacuum pump system, or exhaust port type is used.
L	Manifold individual supply specification ^{Note 20, 21, 22)}	Adjust the supply pressure individually for manifold in order to adjust the vacuum pressure reached by each ejector.
P	Manifold common release pressure supply specification	When selecting "D" (with common release pressure supply (PD) port) for manifold option, supplying a pressure which is different from for common PV to common PD is requested.
W	With exhaust interference prevention valve ^{Note 23, 24, 25)}	When ejectors are operated individually, exhausted air may flow backward from the V port of ejectors that are turned off. Exhaust interference prevention valve prevents backflow.

Note 17) When more than one option is selected, list the option symbols in an alphabetical order. Example) –BJ

Note 18) Use One-touch fitting (M-3AU-4) or barb fitting for piping. (O.D.: within ø5.8)

Note 19) Use One-touch fitting (M-3AU-4) or barb fitting for piping. (O.D.: within ø6.2)

Note 20) Select when a PV pressure of 0.3 MPa or lower is required.

Note 21) Select body for manifold. Select "L" for (5) Options for manifold model. When the common supply and individual supply are mixed, please contact SMC.

Note 22) When "F" or "H" is selected for (1) System/Body type and "L" is selected for (8) Options, the vacuum break flow-adjusting needle option "K" can be additionally selected for increased workability.

Note 23) To prevent backflow of the manifold common exhaust, not for holding vacuum. This option does not completely stop the backflow of the exhaust air. Select port exhaust type depending on purpose.

Note 24) When "J" is selected for (3) Combination of Supply Valve and Release Valve and "W" is selected for (8) Options, install a release valve or vacuum breaker.

Note 25) When "K, Q, R, S" is selected for (5) Pressure Sensor/Pressure Switch for Vacuum Specifications, models with exhaust interference prevention valve is provided. So, it is not necessary to select "W".

Manifold

ZZK2 04 A - A 1 L - -

(1) (2) (3) (4) (5) (6)

● Remains blank when
no option is selected.

(1) Number of stations ^{Note 1)}

Symbol	Stations
01	1 station
02	2 stations
⋮	⋮
10	10 stations

Note 1) In the case of an ejector, for an adequate performance, the number of stations when operated simultaneously depends on the nozzle diameter.

(Refer to Maximum Number of Manifold Stations that Can Operate Simultaneously on [page 75](#))

(2) System (Port combination) ^{Note 2)}

Symbol	System	Port	Standard
P	Vacuum pump system	Common PV: $\varnothing 8$, Common PS: $\varnothing 6$ ^{Note 3)}	Metric size
A	Ejector system	Common PV: $\varnothing 8$ ^{Note 4)}	
PN	Vacuum pump system	Common PV: $\varnothing 5/16''$, Common PS: $\varnothing 1/4''$ ^{Note 3)}	Inch size
AN	Ejector system	Common PV: $\varnothing 5/16''$ ^{Note 4)}	

Note 2) Refer to Port Layout on [pages 60 to 69](#) for the port layout of standard port combinations and options.

Note 3) Common PS port and common PD port are connected inside. Connected One-touch fitting to one of ports so that piping becomes easier. (Connected to PS port initially)

Note 4) Common PV = Common PS = Common PD. Pressure is equal.

(3) Exhaust

Symbol	System	Exhaust type
2	Vacuum pump system	Without silencer
1	Ejector system	Complex exhaust ^{Note 5)} (End plate on both sides) ^{Note 6)}
2		Individual exhaust (Individual port exhaust, High-noise reduction silencer exhaust) ^{Note 7)}

Note 5) The complex exhaust is a combined exhaust method of the common exhaust from the end plate and the direct exhaust from each station.

Note 6) Select "C" for (1) System/Body Type for the single unit model.

Air is exhausted not only from the end plate, but also from the exhaust of each station.

Note 7) Select "F" or "H" for (1) System/Body Type for the single unit model.

(4) Wiring ^{Note 8)}

Symbol	Type
L	Individual wiring ^{Note 9)}
F	D-sub connector (25 pins) ^{Note 10)}
P	Flat ribbon cable connector (26 pins) ^{Note 10)}
N	No wiring (No valve)

Note 8) Common wiring is available only solenoid valve wiring.

Individual wiring is specified for vacuum switches and sensors.

Note 9) Select "L", "L#", or "W" for (6) Wiring Combinations for the single unit model.

Note 10) Select "C", "C1" for (6) Wiring Combinations for the single unit model.

(5) Options ^{Note 11)}

Symbol	Type
Nil	Without option
B	With DIN rail mounting bracket ^{Note 12)}
D	With common release pressure supply (PD) port ^{Note 13)}
L	Manifold individual supply specification ^{Note 14)}

Note 11) When more than one option is selected, list the option symbols in an alphabetical order.

Example) -BD

Note 12) DIN rail should be ordered separately. (Refer to [page 43.](#))

Note 13) When "D" is selected, select "P" for (8) Options for the single unit model. Cannot be selected when (4) Wiring is N.

Note 14) When "L" is selected for (8) Options for the single unit model, specify "L" for manifold, too.

(6) Manifold Assembly

Symbol	Delivery condition
Nil	Individual units assembled delivered as a manifold
FA	Delivered as individual parts (not assembled) ^{Note 15, 16)}

Note 15) Kit consists of end plates for both ends and tension volts.

Note 16) Select when manifold parts are ordered for maintenance. When assembling the manifold, refer to [page 37.](#)

2. Summary of Product Parts

■ Single unit (Ejector system)

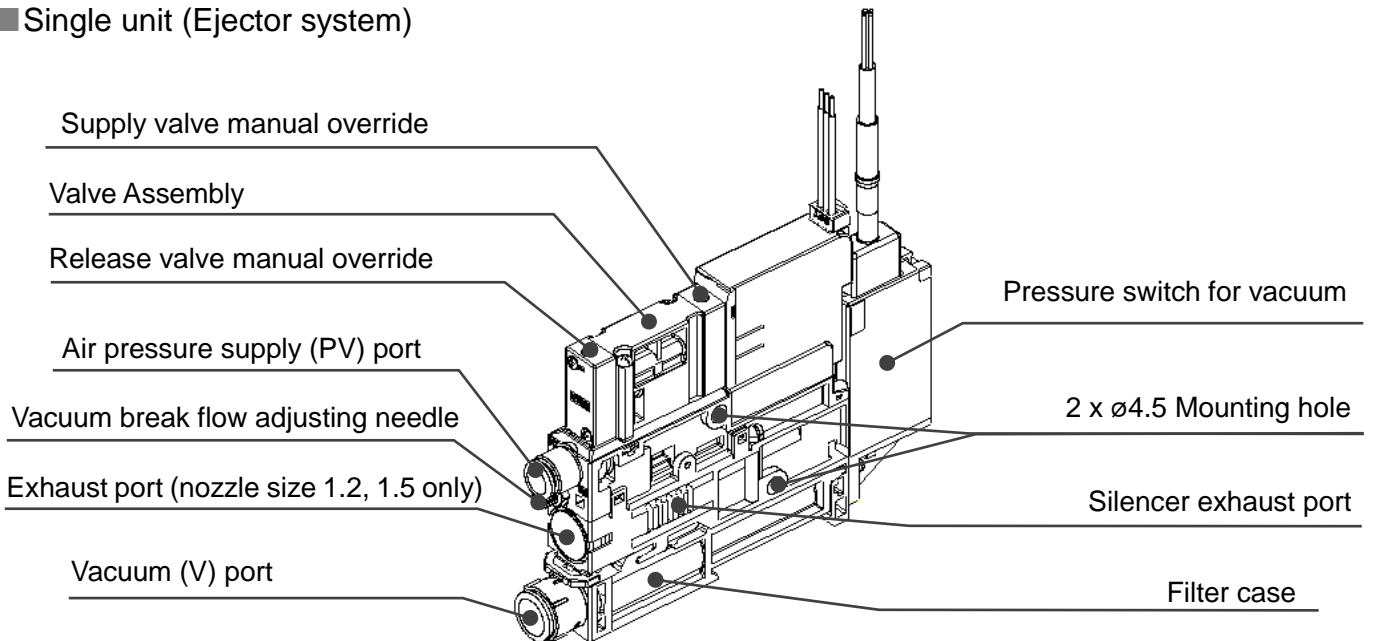

■ Single unit (Vacuum pump system)

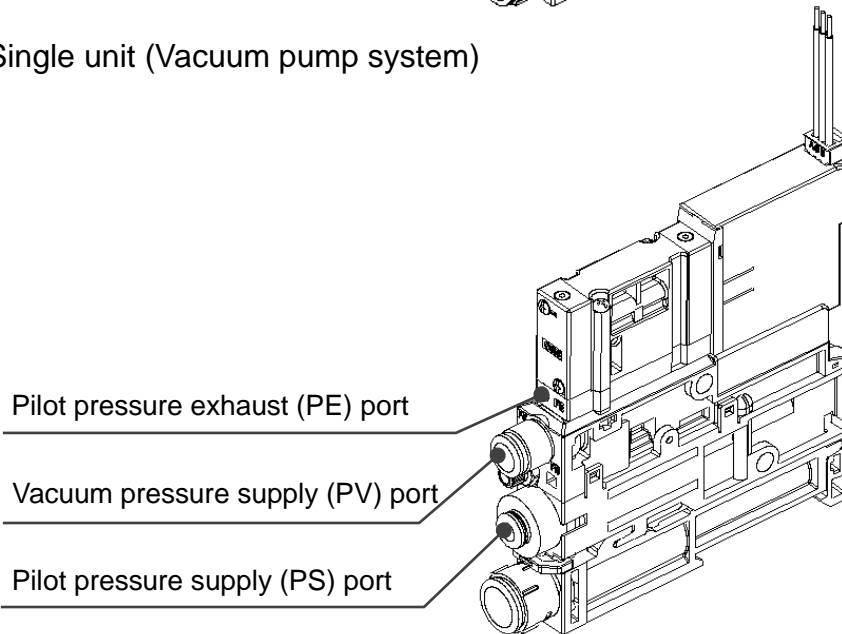

■ Manifold

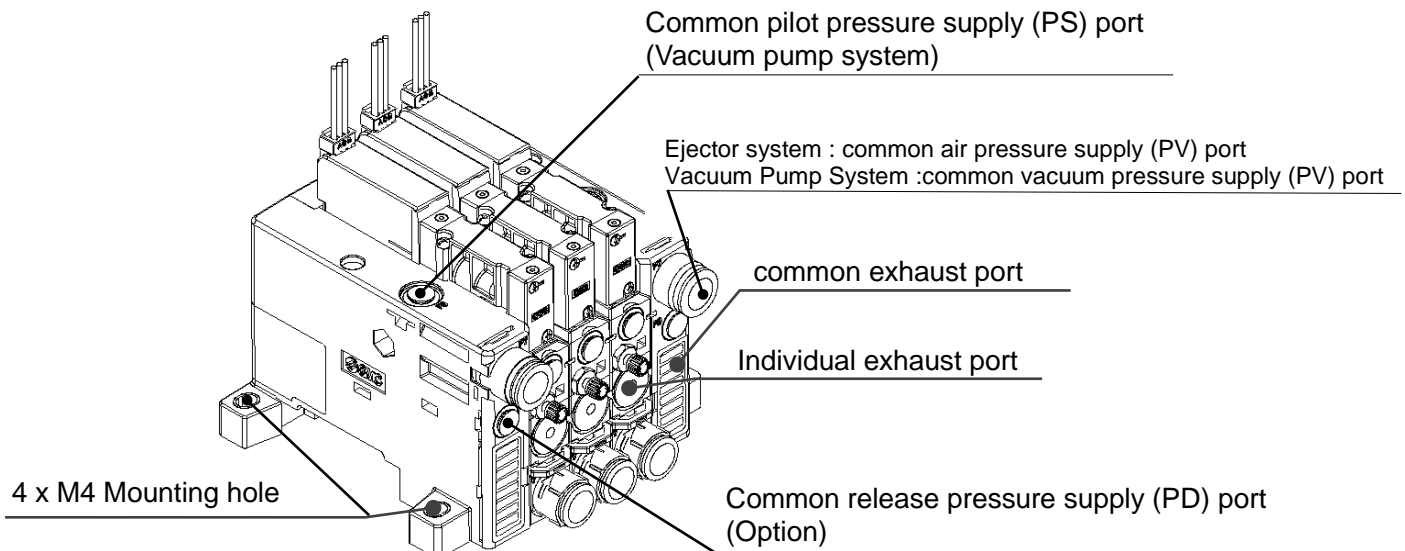

■ Pressure switch for vacuum

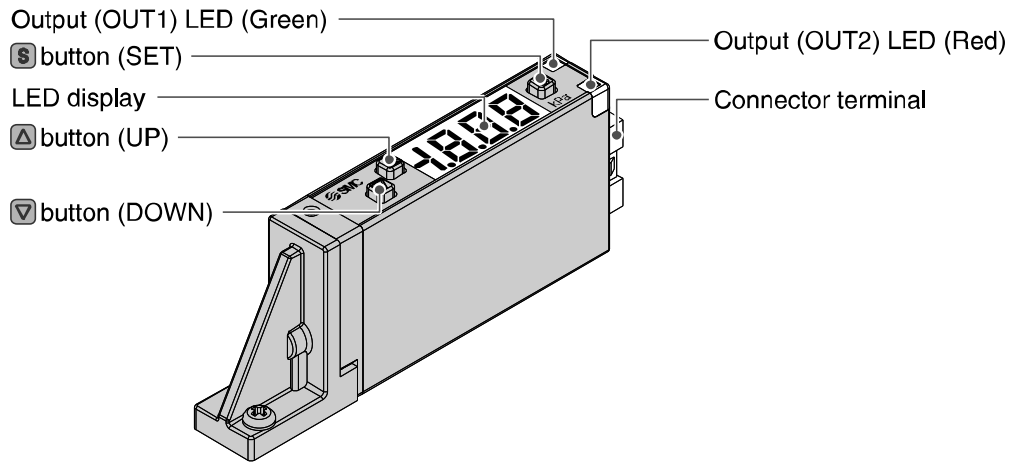

Name	Function
Output (OUT1) LED (Green)	LED (Green) is ON when the switch output (OUT1) is ON.
Output (OUT2) LED (Red)	Pressure switch for vacuum: LED (Red) is ON when the switch output (OUT2) is ON. Pressure switch for vacuum with energy saving function: LED (Red) is ON when the pilot valve for supply valve is energized.
LED display	Displays the current status of pressure, setting mode and error code.
⏴ button (UP)	Selects a mode and increases ON/OFF set value. Press this button to change to the peak display mode.
⏵ button (DOWN)	Selects a mode and decreases ON/OFF set value. Press this button to change to the bottom display mode.
Ⓢ button (SET)	Press this button to change to another mode and to set a value.

3. Installation

3.1. Installation

■ Single Unit

1. DIN rail mounting

- 1) Insert a precision screwdriver into the groove of the release lever and push in direction (1), and slide the filter case in direction (2).
- 2) Hook the ejector onto the DIN rail from direction (3) and mount the ejector onto the DIN rail by pushing it down in direction (4).
- 3) Push the filter case assembly in direction (5) until it is locked.

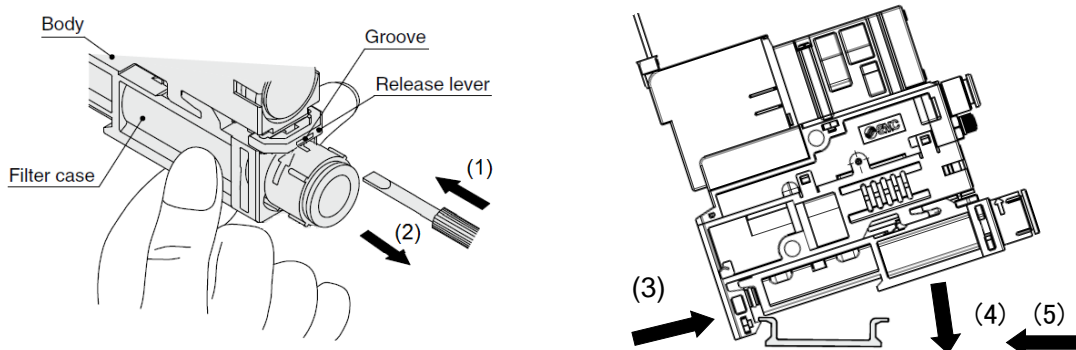

- 4) To hold the ejector onto the DIN rail, hold it from both sides using the stopper brackets.

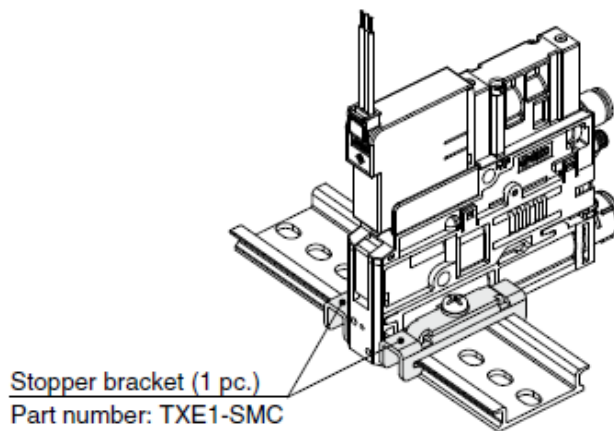

2. Direct mounting

- 1) Mount and tighten the body using the holes in the body (2 x $\phi 4.5$).
(Tightening torque : 0.75 N · m)

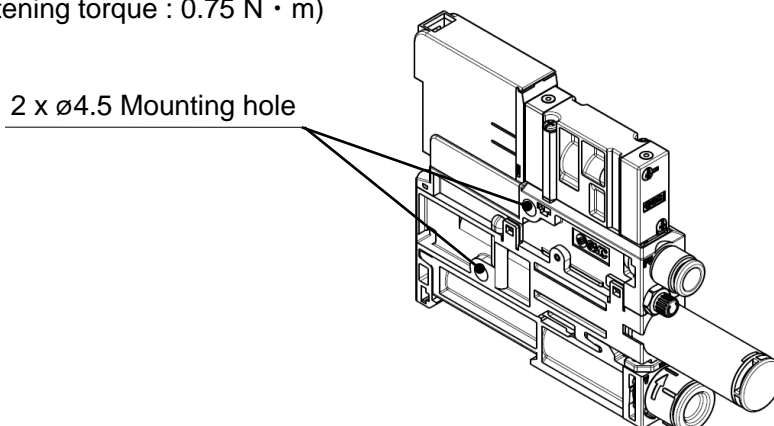

3. Bracket mounting

- 1) Fix the body with the brackets before mounting, using the holes in the body (2 x $\varnothing 4.5$).
- 2) Mount the body using the holes in the brackets.

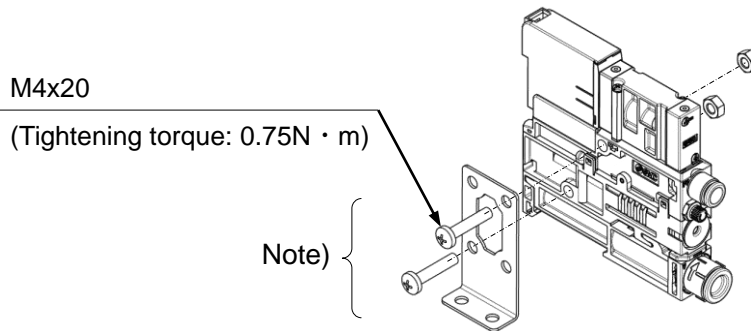

Note) Mounting bracket for single unit (Option) [Nuts and bolts are included.]

Part number: ZK2-BK1-A

■ Manifold

1. DIN rail mounting (Option)

- 1) Hook the mounting bracket of the end plate to DIN rail from direction (1).
 - 2) Mount the ejector onto the DIN rail by pushing it down in direction (2).
 - 3) Use a 50 mm or longer Phillips screwdriver to tighten the mounting bracket (3).
- (Tightening torque: 0.9 \pm 0.1 Nm)

Removal should be performed by following the mounting procedure in reverse.

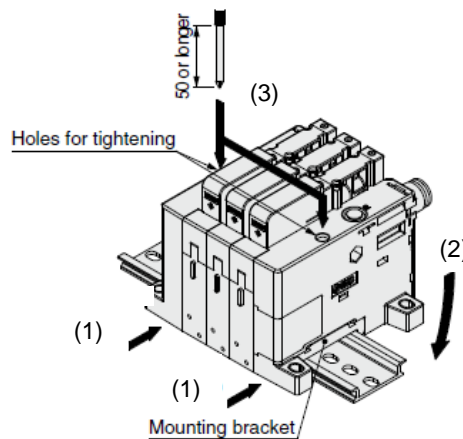

2. Direct mounting

- 1) Mount and tighten the manifold using the holes in the end plate (4 x M4).

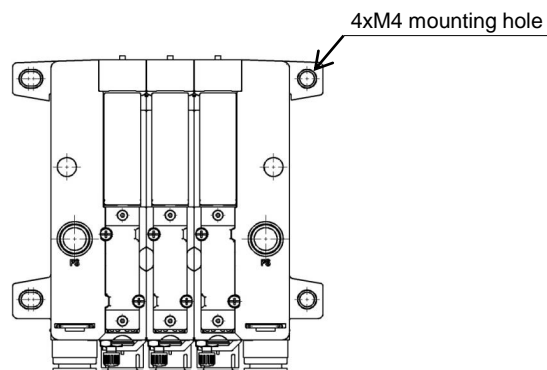

3.2. Air Supply

■ Use clean air

- (1) Using compressed air which contains chemicals, synthetic oils containing organic solvents, salts or corrosive gases, etc. can cause damage or malfunction. Do not use compressed air containing toxic impurities.
- (2) If the compressed air contains excessive drainage or carbon powder, it can stick to the vacuum generating part (the nozzle diffuser) or inside of the solenoid valve or the pressure switch for vacuum and cause deterioration of the performance or operation failure.
- (3) Quality of supply air

It is recommended to use compressed air which purity class is 2:6:3 of ISO8573-1:2010.

Supply air containing foreign matter, water, oil or condensate, etc. can cause malfunction of supply and release valve.

It is recommended that an air filter and a mist separator are connected to the upstream side of the ejector and the pump system to prevent foreign matter (drainage) from entering into the product, and perform periodic maintenance of the mist separator to keep supply air quality.

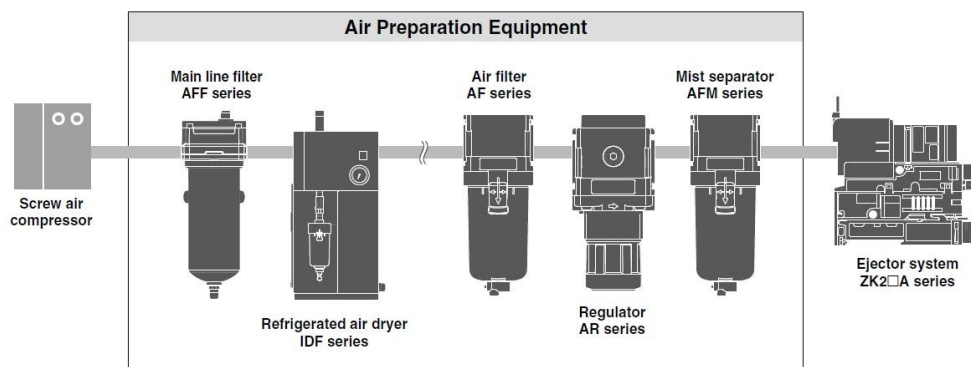

The purity class of compressed air quality based on ISO8573-1:2010

2 : 6 : 3

Solid particle

Class	Max number of particles per m ³ Particle size d (μm)		
	0.1 < d ≤ 0.5	0.5 < d ≤ 1.0	1.0 < d ≤ 5.0
1	≤ 20,000	≤ 400	≤ 10
2	≤ 400,000	≤ 6,000	≤ 100
3	Not specified	≤ 90,000	≤ 1,000
4	Not specified	Not specified	≤ 10,000
5	Not specified	Not specified	≤ 100,000

Moisture

Class	Pressure dew point (°C) at air pressure of 0.7 MPa
1	≤ -70
2	≤ -40
3	≤ -20
4	≤ +3
5	≤ +7
6	≤ +10

Oil

Class	Oil concentration (mg/m ³)
1	≤ 0.01
2	≤ 0.1
3	≤ 1
4	≤ 5

3.3. Piping

■ Single unit

The sizes of the each port are as follows. (Refer to Application and Operating Pressure Range on [page 20](#).)

Port	Size			
	Ejector System		Vacuum Pump System	
	Metric	Inch	Metric	Inch
PV	ø6	ø1/4"	ø6	ø1/4"
V	ø6, ø8	1/4", 5/16"	ø6, ø8	ø1/4", ø5/16"
EXH (Port exhaust)	ø8	ø5/16"	-	-
PE	EXH Common		Port open to atmosphere ^{Note 1)}	
PS	-	-	ø4	ø5/32"
PD ^{Note 2)}	M3	-	M3	-

- : Not applicable

Note 1) Piping for PE port is available as an option (M3). Refer to [page 11](#).

Note 2) A model with PD port (M3) is available as an option. Refer to [page 11](#).

■ Manifold

Manifold ports are common at the end plate. Port description and application are the same as the single unit. Refer to the number of stations that can operate simultaneously for each ejector size on [page 75](#). If one side is not used for air supply, plug the unused port or change to the dedicated port plug as shown below.

	Standard	Port plug assembly part number
Common PV port	ø8 One-touch fitting	VVQZ2000-CP
Common PS port	ø6 One-touch fitting	ZK2-MP1C6-A
Common PD port		

There are 4 types of port combinations depending on the manifold port specification.

	Common EXH port	Common PS/PD port	Application
ZZK2□-A□1□	Yes	PS = PD	Ejector complex exhaust PV = PS = PD
ZZK2□-A□1□-D	Yes	PS ≠ PD	Ejector complex exhaust PV = PS ≠ PD
ZZK2□-A□2□ ZZK2□-P2□	None	PS = PD	Ejector individual exhaust PV = PS = PD
			Vacuum pump system PV ≠ PS = PD
ZZK2□-A□2□-D ZZK2□-P2□-D	None	PS ≠ PD	Ejector individual exhaust PV = PS ≠ PD
			Vacuum pump system PV ≠ PS ≠ PD

When PS = PD, the common PS/PD ports on the end plate are used, PS port is equipped with One-touch fitting and PD port is plugged at the time of shipment from the factory. Since the PS and PD are connected inside the end plate, common supply location can be changed by exchanging the One-touch fitting and the plug.

When PS ≠ PD, PS and PD are not connected inside the end plate. (It is necessary to supply each port individually.)

■ Application and Operating Pressure Range

Port	Description	Ejector System	Vacuum Pump System
PV	Air pressure supply port (Operating pressure range)	Compressed air supply for operating ejector 0.3 to 0.6 MPa ^{Note 1)}	- -
	Vacuum pressure supply port (Operating pressure range)	- -	Vacuum source (vacuum pump) 0 to -100 kPa
PS	Pilot pressure supply port (Operating pressure range)	- -	Compressed air supply for pilot valve 0.3 to 0.6 MPa
	Individual release pressure supply port (Operating pressure range)	Release pressure, Compressed air supply for individual setting (Option) 0 to 0.6 MPa (PD ≤ PV)	0 to 0.6 MPa (PD ≤ PS)
V	Vacuum port	For connecting adsorption equipment including pad	
EXH	Exhaust port	Exhaust when ejector operates ^{Note 2)}	-
PE	Pilot pressure exhaust port	Exhaust when valve operates ^{Note 3)}	

Note 1) For models without valve, pressure can be 0.3 MPa or less. (Ejector system)

Note 2) Manifold can be used at 0.3MPa or less when the manifold is for individual SUP. For 0.2Mpa or less, select K or J for the valve type.

Set pressure as $PV \leq PS$.

Note 3) For ejectors with silencer, air exhausts from A (slit on both sides). For port exhaust type, air exhausts from B.

Note 4) Pilot pressure for ejectors is exhausted from the ejector and the common exhaust. Vacuum pump system exhausts air from PE port on the spacer. (Female thread type (M3) is available by option "C" for PE port of the pump system.)

Male thread type can be selected by option [C] for PE port of vacuum pump system. When option [C] is selected for valve type R, operating conditions below apply.

- Select the type with release pressure supply port (PD) as an option. Single unit / Manifold: Option (D)

Manifold: Option (P)

- Vacuum pressure for PV port: -60 to 100kPa

- Energization time for the relief pilot valve: 200ms or longer when the PD port is released to the atmosphere.

500ms or longer when the 0.1Mpa is supplied to the PD port.

If the product is used out of this operating condition, please contact your local sales office.

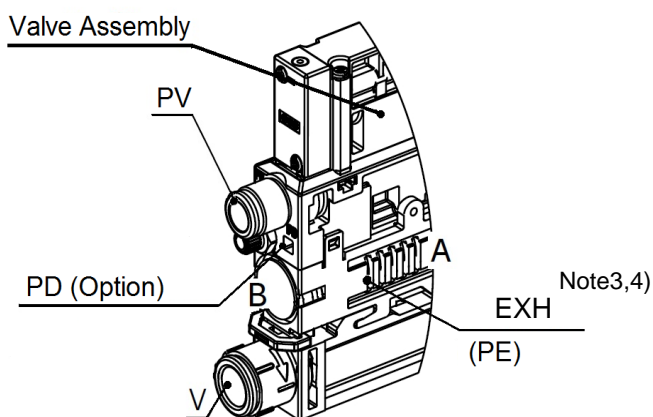

Ejector system

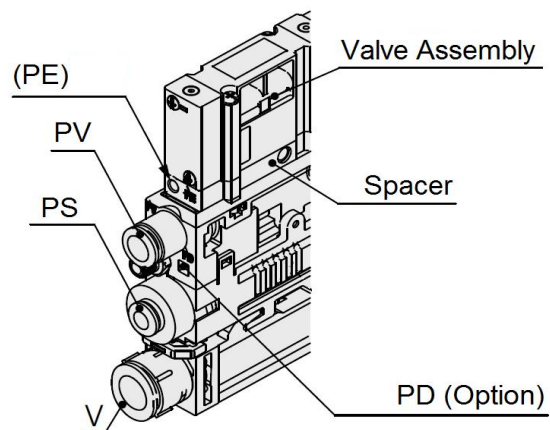

Vacuum pump system

■ Precautions

1. Insertion of the tube

- (1) Cut the tube perpendicularly, being careful not to damage the external surface. Use SMC's tube cutter TK-1, 2 or 3 for cutting. Do not cut the tube with pliers, nippers, scissors, etc. If the tube is cut by any tools other than a tube cutter, the cut surface of the tube will be slanted or flat, making it difficult to be connected securely, causing the tube to come off or air leakage after the tube is connected. Also, allow a sufficient margin of tube length.
- (2) Hold the tube and push it in slowly, inserting it securely all the way into the fitting.
- (3) After inserting the tubing, pull on it gently to confirm that it will not come out. If it is not installed securely all the way into the fitting, problems such as leakage or disconnection of the tube can occur.

2. Removal of the tube

- (1) Push the release button flange evenly and sufficiently to release the tube. Do not push in the tubing before pressing the release button.
- (2) Hold down the release button while pulling out the tube. If the release button is not held down fully, it will be more difficult to pull out the tube.
- (3) If the removed tubing is to be used again, cut off the section of the tubing which has been gripped. Re-using the gripped portion of the tube can cause problems such as air leakage or difficulty in removing the tube.

3. Other manufacturers' tubes

If tubes of brands other than SMC are used, confirm that the materials and tolerance of the tubing outside diameter will satisfy the following specifications.

- (1) Nylon tube: Within ± 0.1 mm
- (2) Soft nylon tube: Within ± 0.1 mm
- (3) Soft polyurethane tube: Within $+0.15$ mm, within -0.2 mm

Do not use tubing which does not meet these outside diameter tolerances.

It may not be possible to connect them, or they may cause other trouble, such as air leakage or the tube pulling out after connection.

4. Piping

(1) Allow a sufficient margin of tube length when piping, in order to prevent twisting, tensile, moment loads, vibration or impact being applied to the tubes and fittings.

This can cause damage to the tube fittings and crushing, bursting or disconnection of tubing.

(2) Piping to the product is assumed to be static piping.

If the tube moves, it may become worn, elongated or torn due to tensile forces, or disconnected from the fitting. Ensure the tube is in a static condition at all times before using.

(3) Prevent the connected tube from being rotated.

If the fittings are used in this way, the fitting may be broken.

(4) Do not lift the product by holding the piping after the tube is connected to the vacuum (V) port.

Otherwise, the filter case and/or the One-touch tube fitting will be damaged.

4. Solenoid Valve

Manual override operation

Manual override is non-locking push type. Push the manual override with a screwdriver of a diameter smaller than indicated in the diagram until it reaches the end.

Confirm that the product operates safely before the manual override is operated.

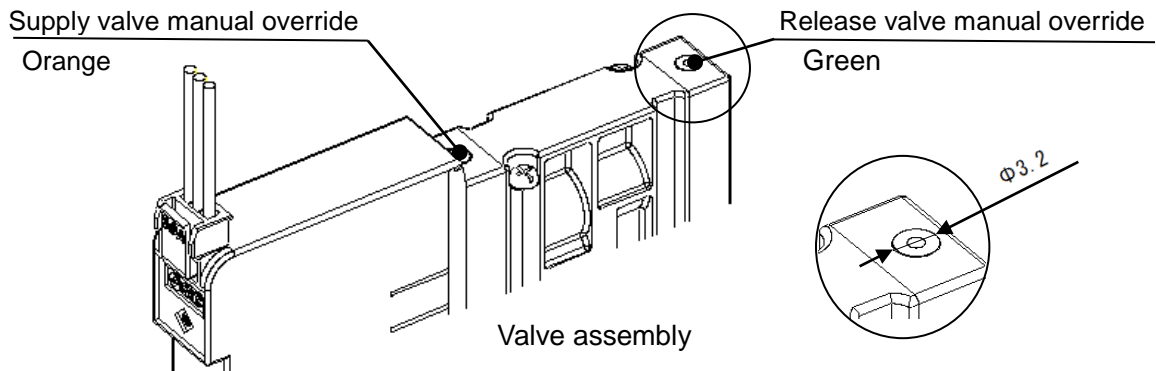

Note 1) When valve type R is selected, the supply valve can hold the position and will not switch off even if the supply valve manual override operation is finished unless the release valve manual override is pressed.

Self-holding function of supply valve (Valve type R) ^{Note 2) 3) 4)}

When the supply valve is energized (20 ms or more), the supply valve keep ON position even after energization is stopped. When release valve is energized, the supply valve is turned off in conjunction with the operation of the release valve.

Note 2) Main valve in the valve assembly is made of elastic seal. Self-holding is performed by friction resistance of the seal. Do not apply impact resistance in the direction of the main valve shaft during the installation to moving parts. When impact is applied, use valve type K. (For vibration and impact, refer to General Specifications on [page 55](#).)

Note 3) In a vacuum pump system, the workpiece may not be released when the vacuum break flow adjusting needle is closed during the use. In addition, the OFF operation of the supply valve may become unstable. Open the vacuum break flow adjusting needle during use. If the vacuum break flow adjusting needle is expected to close during use due to a light workpiece, please select PD port type (single unit: manifold option[D])(for manifold: option [P]). Release the PD port to the atmosphere and open the vacuum break flow adjusting needle.

Note 4) Valve type R cannot use a pressure switch for vacuum with energy saving function.

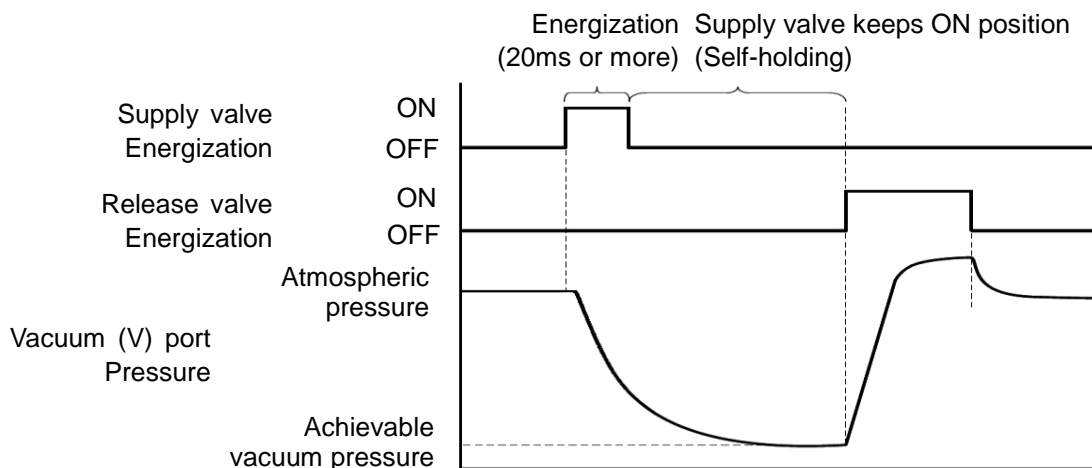

Default setting

When the valve assembly is delivered, the supply valve is on the OFF position, but it may be on the ON position due to the vibration or impact during transportation or device installation. Turn to the OFF position manually or by energizing before use.

■ Continuous duty

If a supply valve is energized continuously for a long time, the rise in temperature due to heat-up of the coil may cause a decline in solenoid valve performance, reduce service life, or have adverse effects on peripheral equipment. When the energizing time per day is longer than non-energizing time, use the self-holding function of valve type R. (Energized time should be 20ms or longer, and be as short as possible.)

■ Air leakage

Zero air leakage is not guaranteed for the supply valve or release valve. Be aware that because there is a chance of air and vacuum leakage, the pressure may change if the V port side is tightly sealed.

■ Electrical wiring

. Wiring

(1) Individual wiring

To install the connector, hold the cover and insert the connector straight pushing the connector lever with your finger. Ensure that the connector lever clip is properly inserted onto mating part.

To remove the connector, hold the cover and pull out the connector straight pushing the connector lever clip.

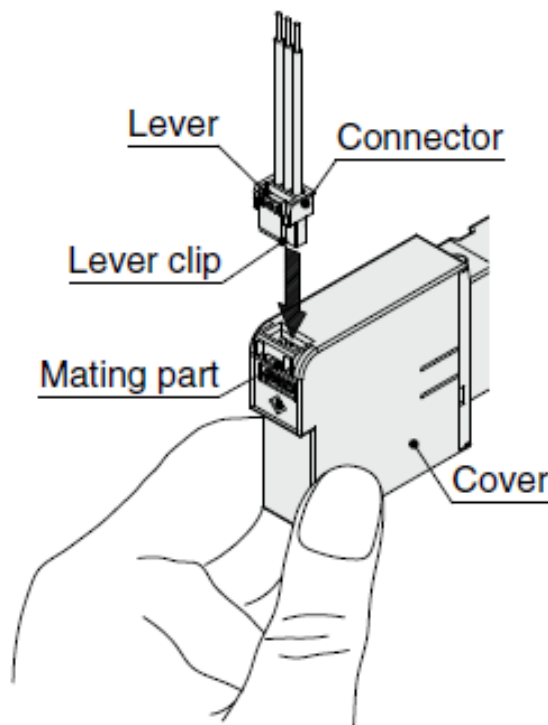

Note) Do not pull the lead wire excessively, as this damage the connector or cover.

(2) Common wiring

Align the socket connector of the cable and the plug connector of the manifold.

Insert the socket connector of the cable into the plug connector of the manifold vertically.

If the connector is pushed forcibly, the pin will bend and the connector cannot be joined.

Example) D-sub connector

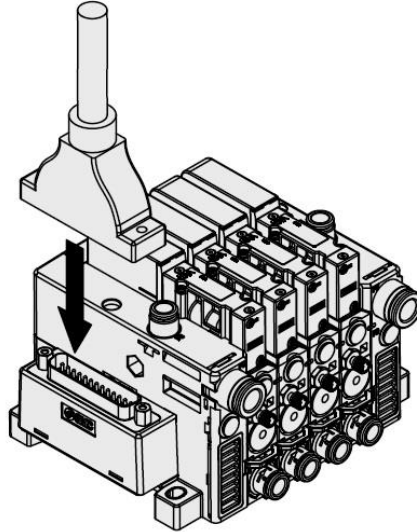

2. Internal Circuit

Wiring should be connected as shown below. Connect with the power supply respectively. Light/surge voltage suppressor circuit is equipped for the valve type J, K and R. Solenoid valve is non-polar type.

(1) Individual wiring

Valve type: J

(With supply valve, Without release valve)

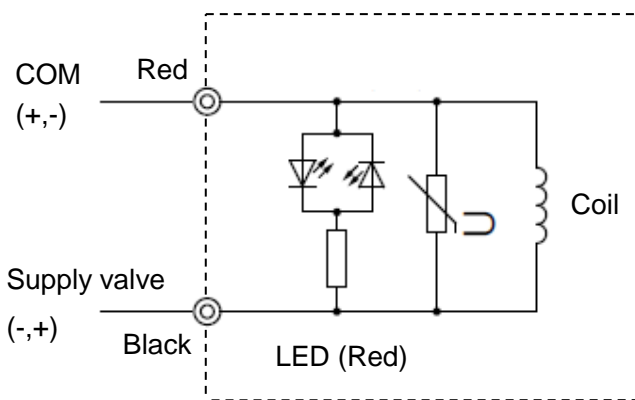

Valve type: K, R

(With supply valve, With release valve)

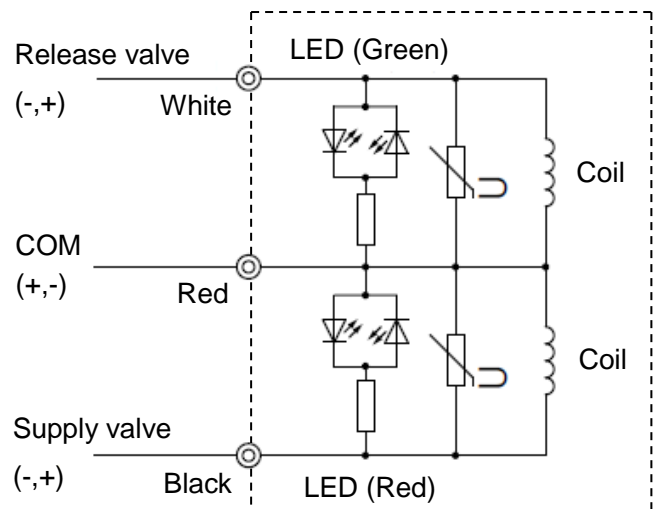

(2) Common wiring

2-1) D-sub connector

A D-sub connector conforming to MIL standards is used.

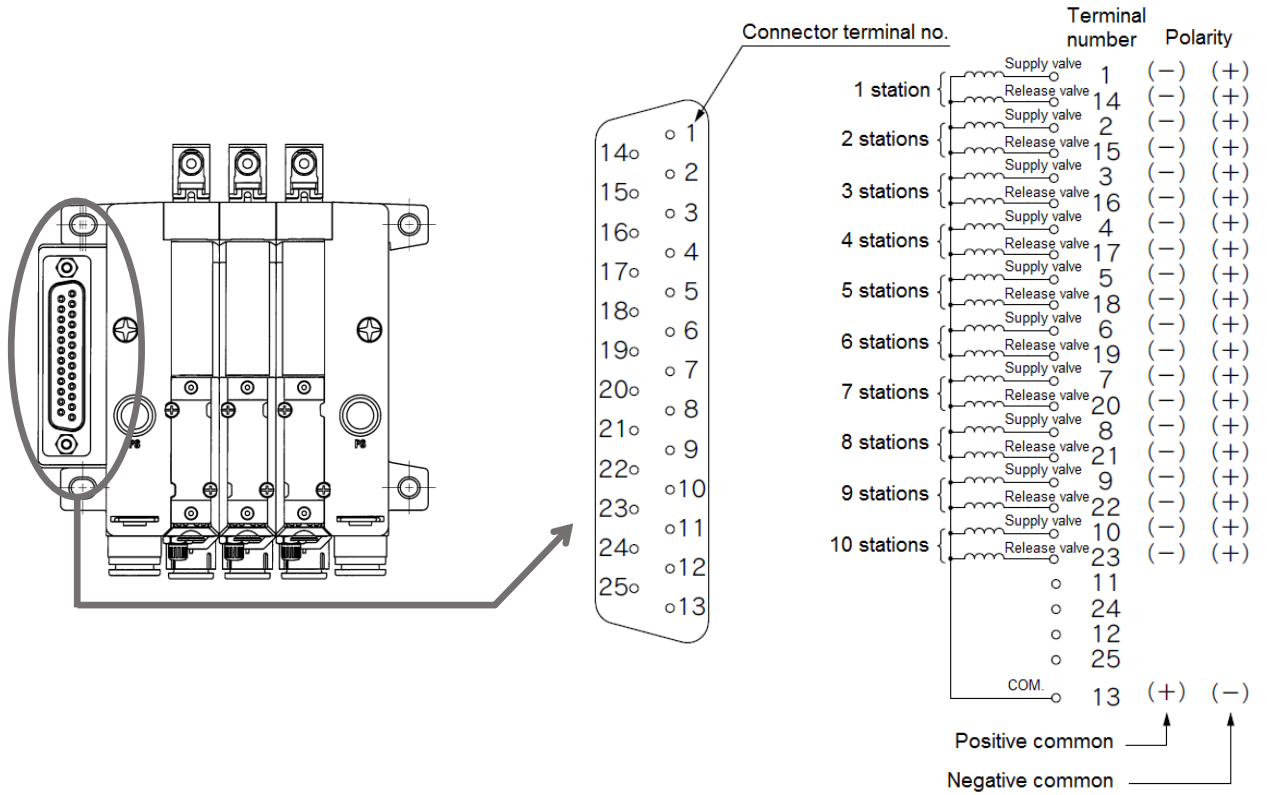

2-2) Flat ribbon cable connector

A flat ribbon cable connector conforming to MIL standards is used.

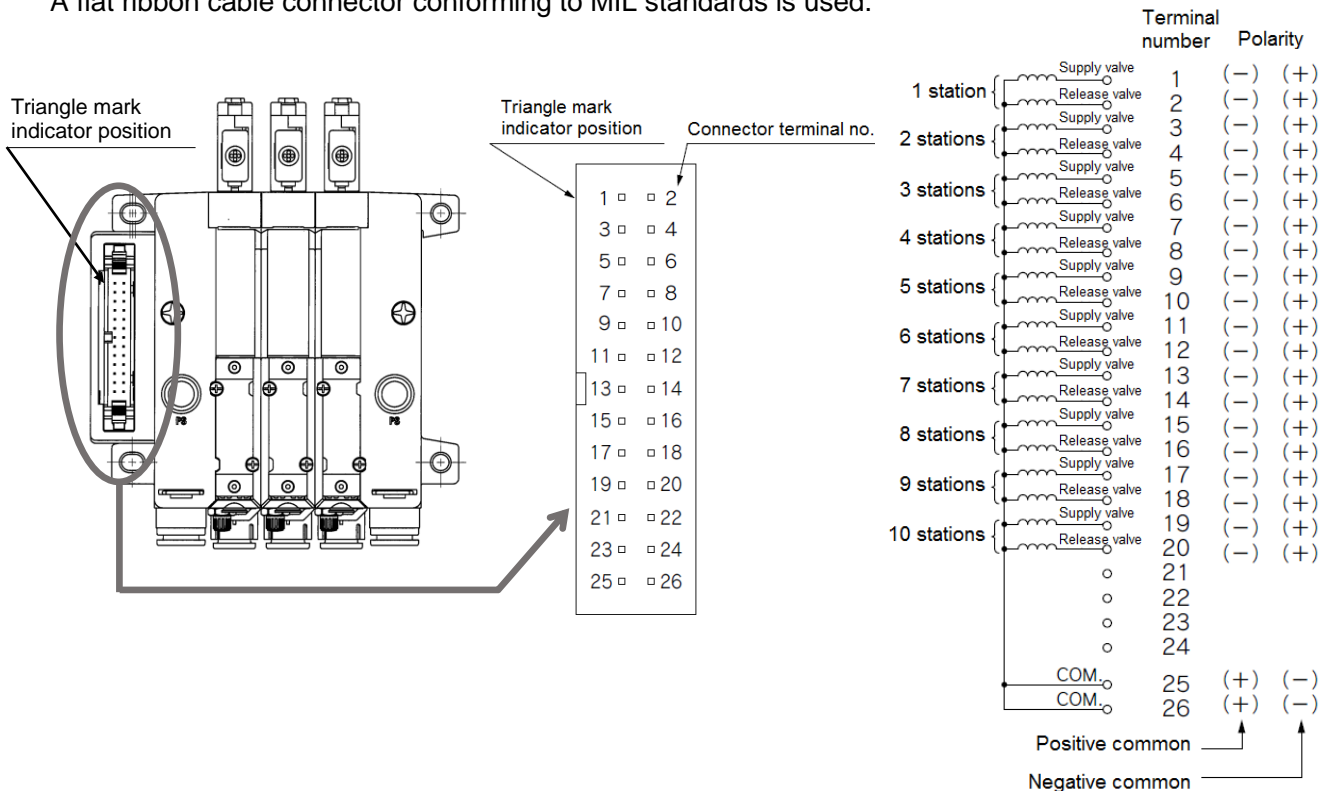

3. LED indication

Red LED turns on when supply valve is energized. Green LED turns on when release valve is energized.

(1) Individual wiring

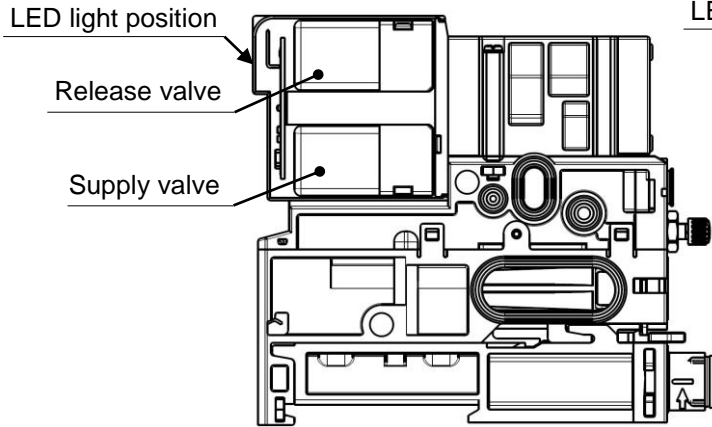

(2) Common wiring

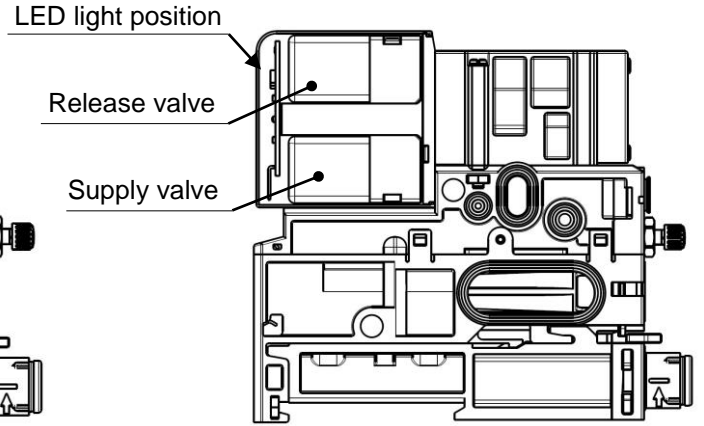

4. Cable assembly for common wiring

D-sub connector cable assembly

(1) Assembly part number

AXT100-DS25-□

Symbol(□)	Cable length L (m)	Note
015	1.5	Cable 0.3mm ² x 25 cores
030	3	
050	5	

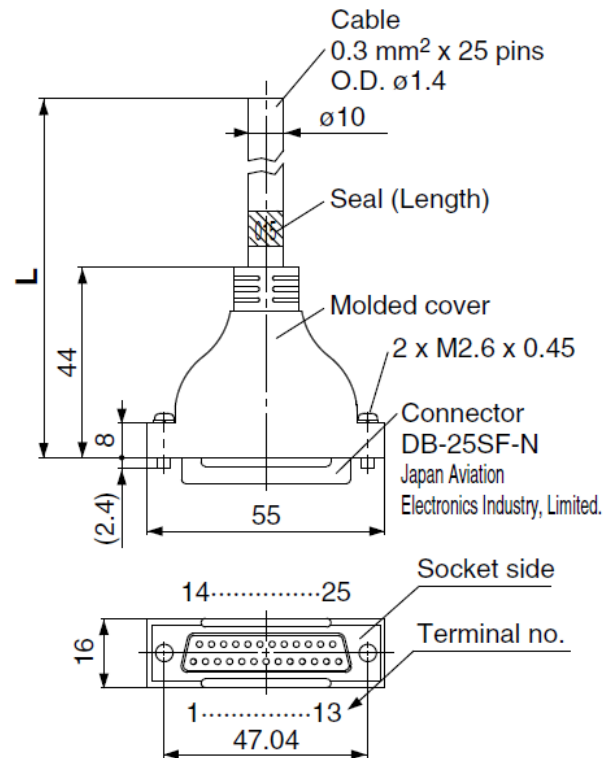

For other commercial connectors, use a 25-pin type with female connector conforming to MIL-C-24308.
Cannot be used for movable wiring.

(2) Terminal number and Wire color

Terminal number	Wire Color	Dot Marking	Terminal number	Wire Color	Dot Marking	Terminal number	Wire Color	Dot Marking
1	Black	None	11	White	Red	21	Brown	White
2	Brown	None	12	Yellow	Red	22	Pink	Red
3	Red	None	13	Orange	Red	23	Gray	Red
4	Orange	None	14	Yellow	Black	24	Black	White
5	Yellow	None	15	Pink	Black	25	White	None
6	Pink	None	16	Blue	White			
7	Blue	None	17	Purple	None			
8	Purple	White	18	Gray	None			
9	Gray	Black	19	Orange	Black			
10	White	Black	20	Red	White			

(3) Electrical Characteristics

Item	Property	Note
Conductor resistance	65Ω/km or less, 20°C	Cable 0.3mm ² x 25 cores
Voltage limit	AC 1000V, 1min	
Insulation resistance	5MΩ/km, 20°C	

Note) The minimum bending inner radius of D-sub connector cable is 20mm.

Connector manufacturers' example

Fujitsu Limited
 Japan Aviation Electronics Industry, Limited.
 J.S.T. Mfg. Co., Ltd.
 HIROSE ELECTRIC CO., LTD.

Flat ribbon cable connector assembly

(1) Assembly part number

AXT100-FC26-□

Symbol(□)	Cable length L (m)
1	1.5
2	3
3	5

For other commercial connectors, use a 26-pin type with strain relief conforming to MIL-C-83503.
 Cannot be used movable wiring.

(2) Terminal number

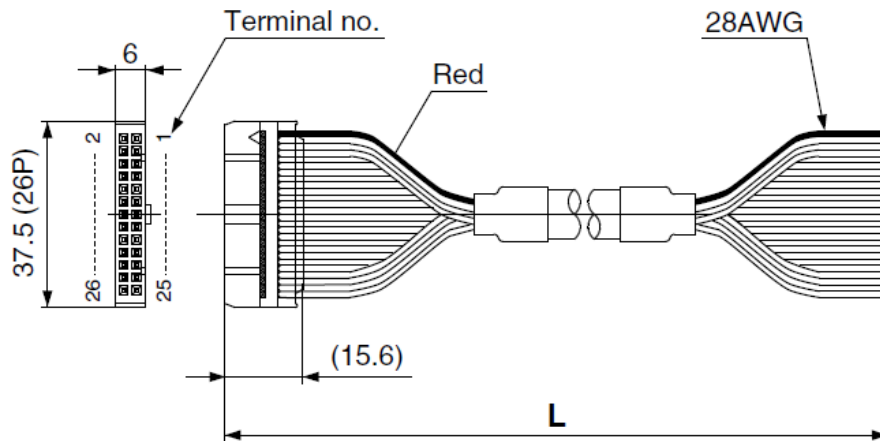

Connector manufacturers' example

- HIROSE ELECTRIC CO., LTD.
- Japan Aviation Electronics Industry, Limited.
- 3M Japan Limited
- J.S.T. Mfg. Co., Ltd.
- Fujitsu Limited
- Oki Electric Cable Co., Ltd.

5. Pressure Sensor/Pressure Switch

Internal circuit and wiring examples

Pressure sensor

ZK2-PS□-A

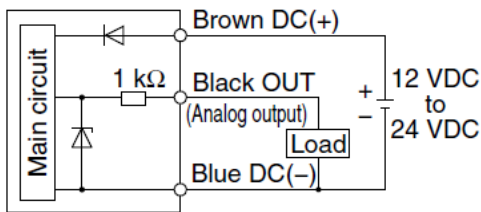

Voltage output type: 1 to 5 V
Output impedance: Approx. 1 kΩ

Pressure switch for vacuum

ZK2-ZS□A□□-A (NPN 2 outputs)

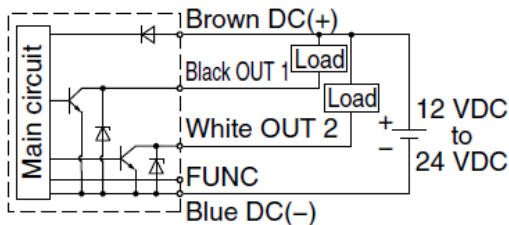

Max. 28 V, 80 mA
Residual voltage: 2 V or less

ZK2-ZS□B□□-A (PNP 2 outputs)

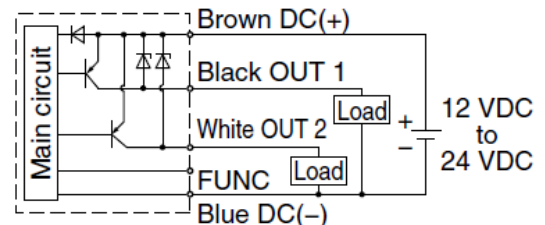

Max. 80 mA
Residual voltage: 2 V or less

The FUNC terminal is connected when using the copy function. (Refer to the ZSE10/ISE10 Operation Manual)

Pressure switch for vacuum with energy saving function

ZK2-ZSVA□□-A (NPN 1 output)

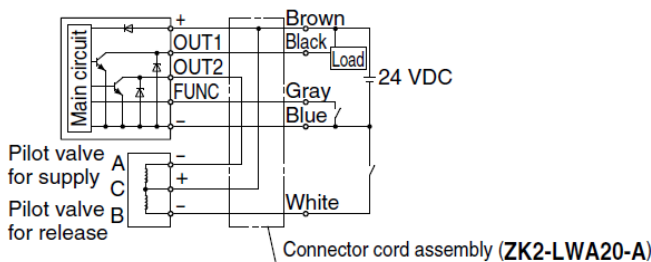

ZK2-ZSVB□□-A (PNP 1 output)

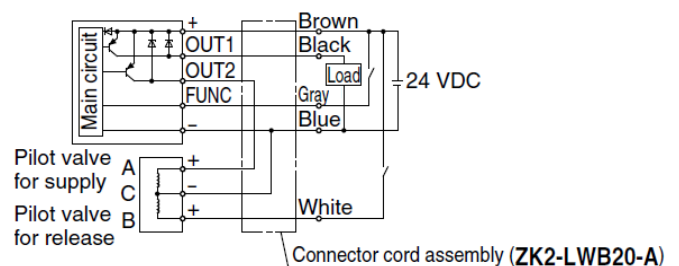

The FUNC terminal is connected when operating the supply valve by energy saving control (for workpiece adsorption).

(Refer to the ZK2-ZSV□□□-A Operation Manual)

6. Construction/Replacement Parts

6.1. Construction for Single Unit

(Including single unit for manifold)

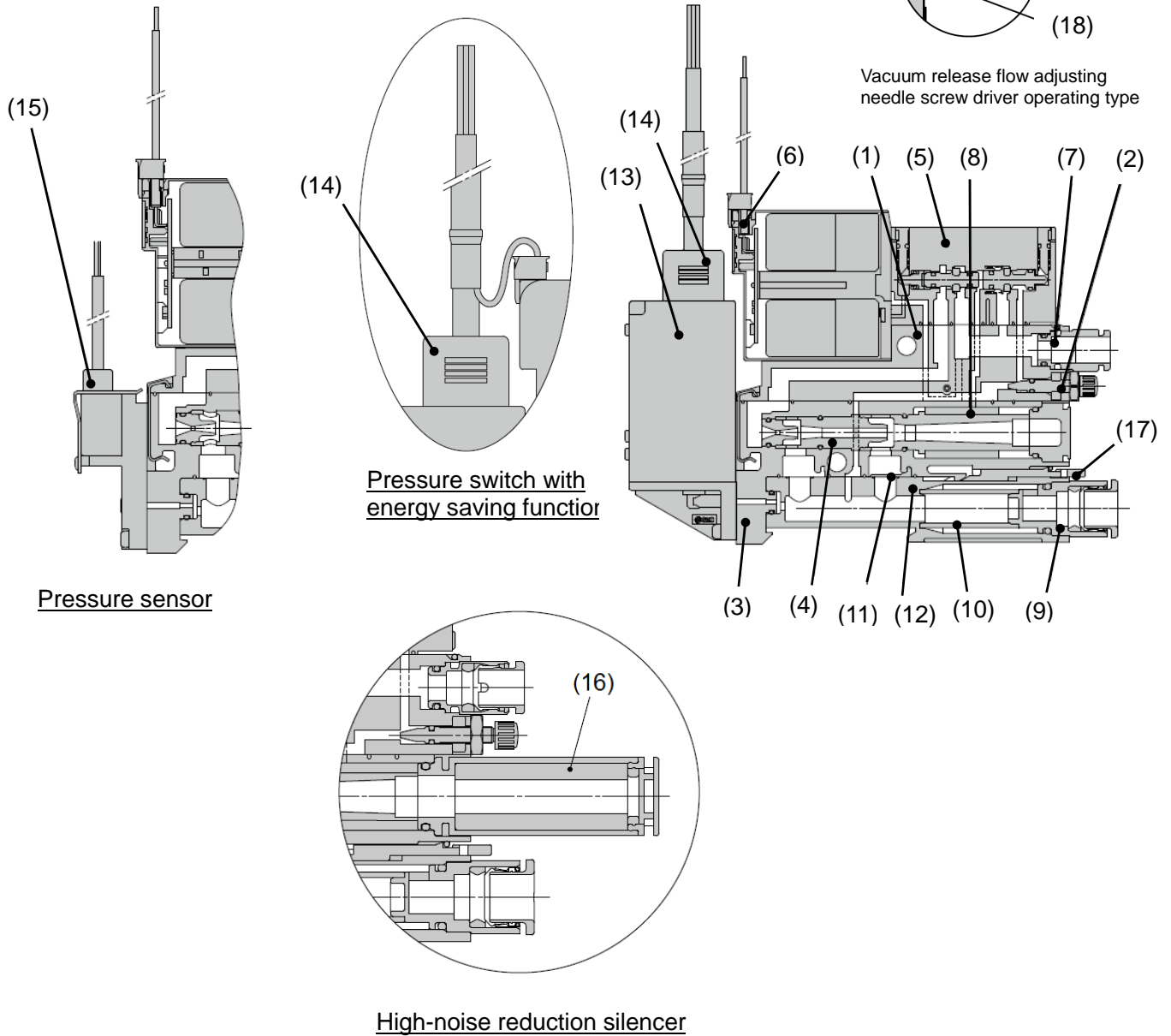

6.2. Component Parts

No.	Item	Material	Remarks
1	Valve body assembly	PBT	HNBR, NBR and steel are also used
2	Needle assembly	Brass	Electroless nickel plated brass, resin, steel and NBR are used
3	Ejector body assembly	PBT	HNBR, NBR and steel are also used
4	Ejector assembly	PBT	NBR is also used

6.3. Replacement Parts

No.	Item	Remarks
5	Valve assembly	-
6	Connector assembly	Connector for solenoid valve 3 wires (For valve type K, R), 2 wires (For valve type J)
7	One-touch fitting assembly	Standard supply (PV) port: $\varnothing 6, \varnothing 1/4''$
8	Sound absorbing material	10 pcs. per set
9	Vacuum port adapter assembly	With One-touch fitting and filter element
10	Filter element	Nominal filtration rating: 30 μm , 10 pcs. per set
11	Body gasket	Gasket integrated with the exhaust interference prevention valve. (10 pcs. per set)
12	Filter case	Case body: Polycarbonate (Refer to Note on P.53) Clear filter case: without a port for the pressure switch or sensor, Opaque filter case: with a port for the pressure switch or sensor.
13	Pressure switch for vacuum assembly	With 2 screws and 1 O-ring
14	Lead wire with connector	-
15	Pressure sensor assembly	With 2 screws and 1 O-ring
16	High-noise reduction silencer assembly	With sound absorbing material (High-noise reduction silencer)
17	Release lever	10 pcs. per set
18	lock nut	10 pcs. per set

6.4. Replacement Parts for Single Unit/How to Order

(Including single unit for manifold)

(5) Valve assembly

ZK2-VA A K 5 L **A-** **-A**
 [1] [2] [3][4] [5]

[1] Applicable system

A	Ejector system
P	Vacuum pump system

[2] Valve type

K	Supply valve: N.C., Release valve: N.C.
R	Supply valve: Self-holding release valve linked, Release valve: N.C.
J	Supply valve: N.C., Release valve: None

[3] Rated voltage

5	24 VDC
6	12 VDC

[4] Wiring

C	Manifold common wiring
L	Individual wiring, with connector assembly (lead wire length: 300mm)
LO	Individual wiring, without connector assembly connector

[5] Other specification

C	Vacuum pump system (Valve type:R) PE port female thread specification (M3)
Nil	Specification other than that listed above.

Select the ZK2-VAAK5LA- -A for a pressure switch with energy saving function.

This assembly does not include special cable assembly for a pressure switch with energy saving function.

(6) Connector assembly

ZK2-LV W **- A**

● Applicable valve type

W	Valve type K, R (With supply valve and release valve)
S	Valve type J (Supply valve only)

● Lead wire length

Nil	300 mm
6	600 mm
10	1000 mm
20	2000 mm
30	3000 mm

Valve type: K, R

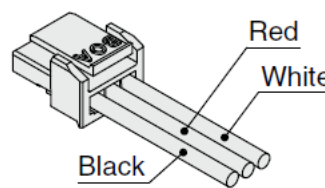

Valve type: J

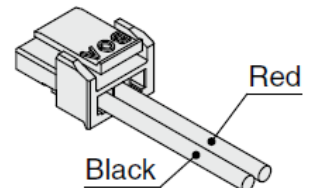

(7) One-touch fitting assembly

(Purchasing order is available in units of 10 pieces.)

KJH 06 **- C2**

● Port size

06	ø6 One-touch fitting (Straight)	Metric size
07	ø1/4" One-touch fitting (Straight)	Inch size

(8) Sound absorbing material
(10 pcs. per set)

ZK2-SE1-1-A

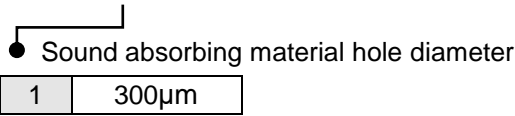

(9) Vacuum port adapter assembly
(Purchasing order is available in units of 1 piece.)

ZK2-VA1S 8 -A

● One-touch fitting size

6	ø6 One-touch fitting	Metric size
8	ø8 One-touch fitting	
7	ø1/4" One-touch fitting	Inch size
9	ø5/16" One-touch fitting	

(10) Filter element
(10 pcs. per set)

ZK2-FE1-3-A

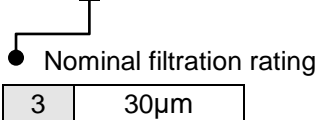

(11) Body gasket ^{Note)} (10 pcs. per set)

ZK2-BG5 1 -A

● Specification

1	One check valve type (All specifications other than vacuum switch with energy saving function and exhaust interference prevention valve)
2	Two check valve type (Vacuum switch with energy saving function and exhaust interference prevention valve)

Note) When ZK2-BG5-2-A is mounted, the workpiece cannot be removed until vacuum is released.

(12) Filter case ^{note)}

ZK2-FC□ -A

● Port for the pressure switch or sensor

Symbol	Port for the pressure switch or sensor	Filter case color
P	With port (type with pressure switch or sensor)	Smoke
T	Without port (type without pressure switch or sensor)	Clear

Note) Vacuum port adapter assembly is not included.

(13) Pressure switch for vacuum assembly

ZK2-ZS **E** **A** **M** **G** □ - A

[1] [2] [3] [4] [5]

[1] Rated pressure range and function

E	0 to -101 kPa	Pressure switch for vacuum	Open collector 2 outputs
F	-100 to 100 kPa		
V	-100 to 100 kPa	Pressure switch with energy saving function	Open collector 1 output

[2] Output specifications

A	NPN
B	PNP

[3] Unit specifications

Nil	Unit selection function ^{Note 1)}
M	SI unit only ^{Note 2)}

Note 1) The unit selection function is not available in Japan due to new measurement law.

Note 2) Fixed unit: kPa

[4] Lead wire with connector

Nil	None
G	When 1. Is "E" or "F": For pressure switch for vacuum ,lead wire with connector (Length 2m)
	When 1. Is "V": For pressure switch with energy saving function,lead wire with connector

[5] Mounting ^{Note)}

Nil	Mounted to the single unit
L	Mounted to the manifold

The length of the mounting screw ejector included in the package is different.

Note) When ordering an ejector without valve, select Nil for mounting.

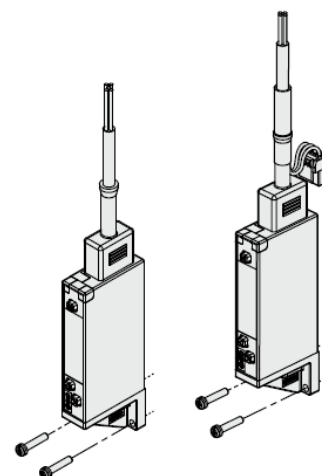

(14) Lead wire with connector

(When individual lead wire is necessary, order with the part number below.)

Lead wire with connector for pressure switch for vacuum

ZS-39-5G

Lead wire with connector for pressure switch with energy saving function

ZK2-LW A 20-A

● Output

A	NPN open collector
B	PNP open collector

(15) Pressure sensor assembly

ZK2-PS 1 - A

● Rated pressure range and specifications

1	0 to -101 kPa, Output: 1 to 5 V, Accuracy: ±2% F.S.
3	-100 to 100 kPa, Output: 1 to 5 V, Accuracy: ±2% F.S.

● Mounting ^{Note)}

Nil	Mounted to the single unit
L	Mounted to the manifold

The length of the mounting screw ejector included in the package is different.

Note) When ordering an ejector without valve, select Nil for mounting.

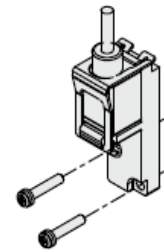

(16) High-noise reduction silencer assembly

ZK2-SC3- 4 -A

● Applicable nozzle size

4	Φ4	For nozzle size 07, 10
6	Φ6	For nozzle size 12, 15

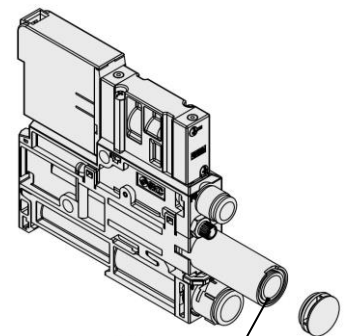

Sound absorbing material for high-noise reduction silencer

Part number : ZK2-SE4-6-A

(5 pcs. per set)

(17) Release lever(10 pcs. per set)

ZK2-RL1-A

(18) Lock nut(10 pcs. per set)

ZK2-LN1-A

7. Exploded View of Manifold/Replacement Parts

7.1. Exploded View of Manifold

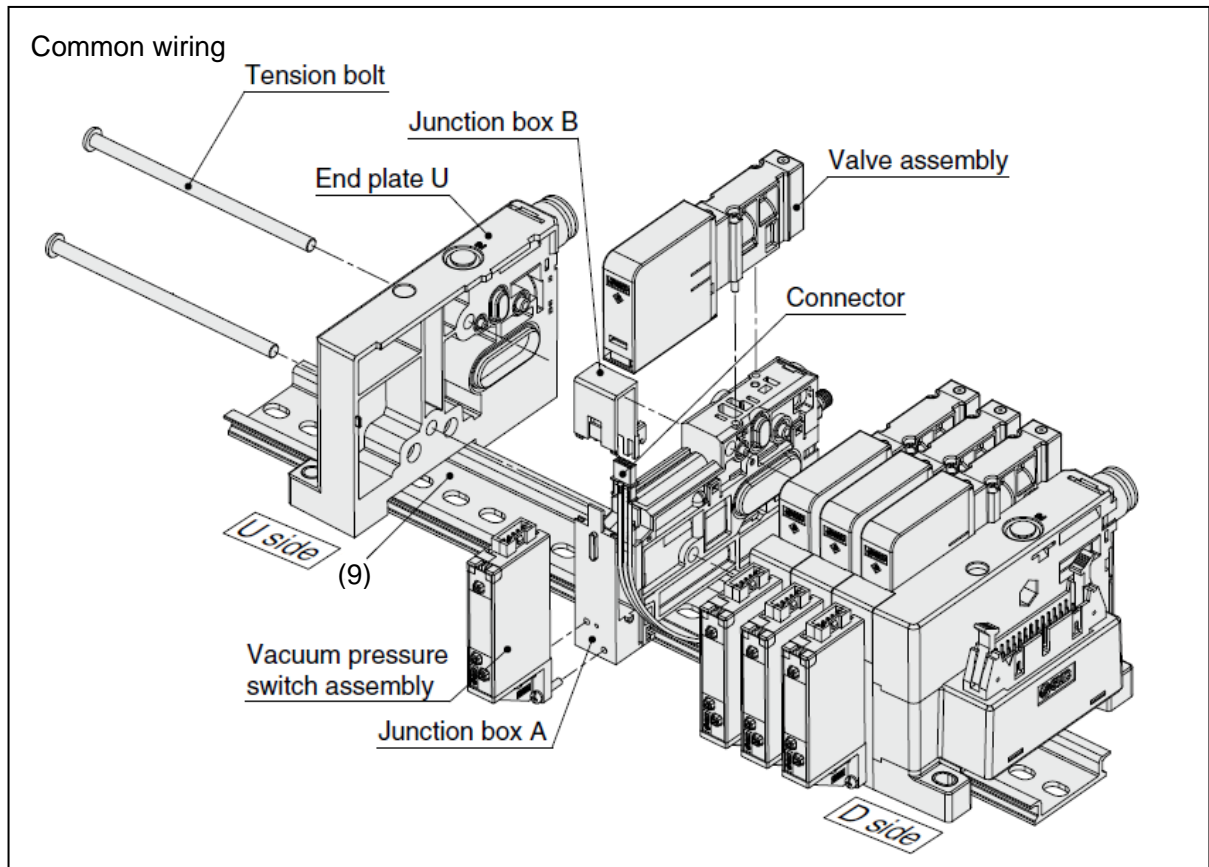
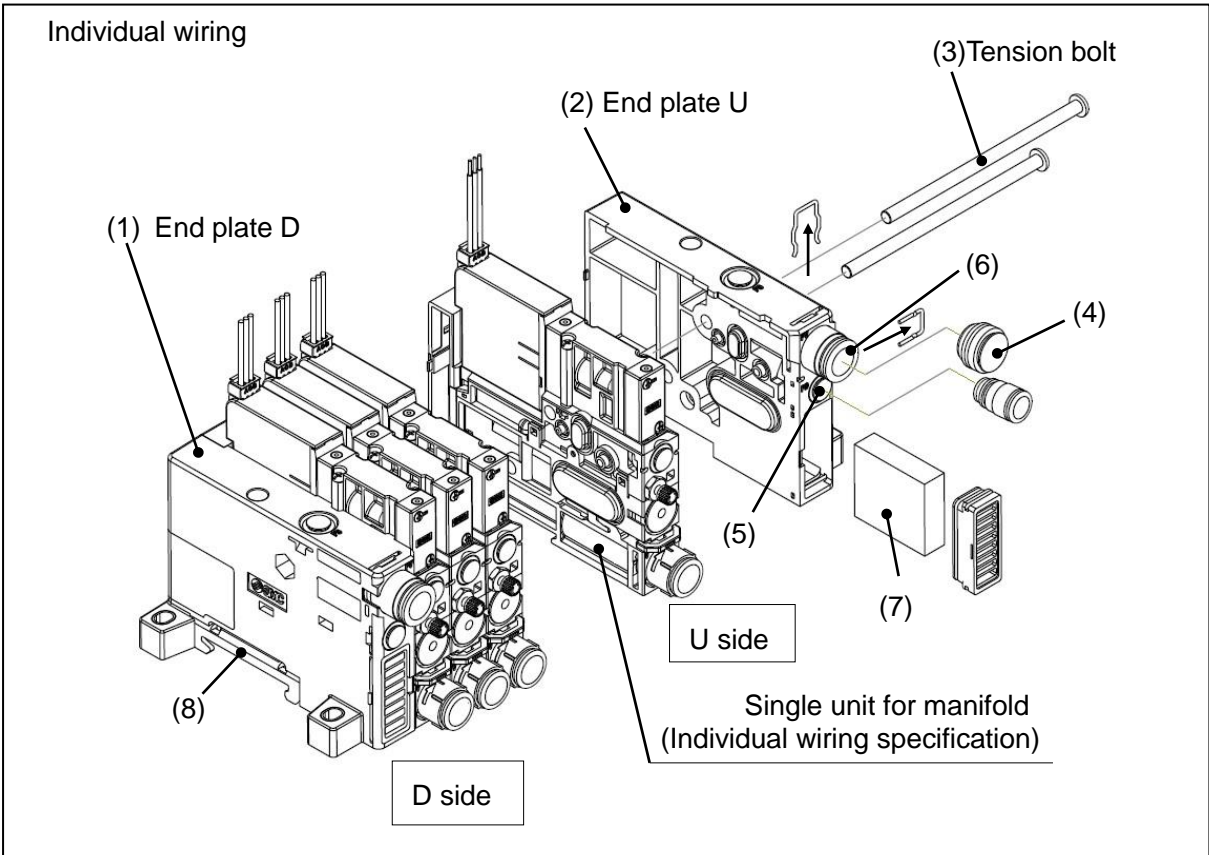

7.2. How to Increase Manifold Stations

7.2.1 Individual wiring specifications

- 1) Remove two tension bolts.
- 2) Remove the end plate U. (Be careful not to drop the gasket.)
- 3) Mount a single unit to the end surface of U side. (Do not let the gasket get caught.)
- 4) Mount the end plate U with the appropriate length of tension bolts for the number of stations required.
(Tightening torque: 0.75 Nm)

7.2.2 Common wiring specifications

■ To increase the number of stations from odd number (1, 3, 5, 7, 9) to even number (2, 4, 6, 8, 10)
(Common wiring of odd number station has a vacant connector for one station. Easy to add a station.)

- 1) Remove two tension bolts.
- 2) Remove the end plate U.
- 3) Remove the valve assembly of a single unit for extra station for manifold.
- 4) Remove the switch assembly if it is present. (Be careful not to drop the O-ring. Refer to **Fig.1**)
- 5) Remove the junction box B (top) using a precision screwdriver. (Refer to **Fig.2**)
- 6) Mount the extra connector to the junction box B. (Refer to **Fig.3**)
(Engage the recess of the connector and the protrusion of the junction box B. (Refer to **Fig.3-A**))
- 7) Mount a single unit for extra station for manifold to the end surface of U side.
(Do not let the gasket or lead wire get caught.)
- 8) Mount the end plate U with the appropriate length of tension bolts for the number of stations required.
(Tightening torque: 0.75 Nm.)
- 9) Mount the junction box B to the junction box A.
- 10) Assemble the valve assembly. (Tightening torque: 0.15 Nm)
- 11) For products with a switch, mount the switch assembly.
(Be careful not to drop the O-ring. Tightening torque: 0.08 to 0.10 Nm)

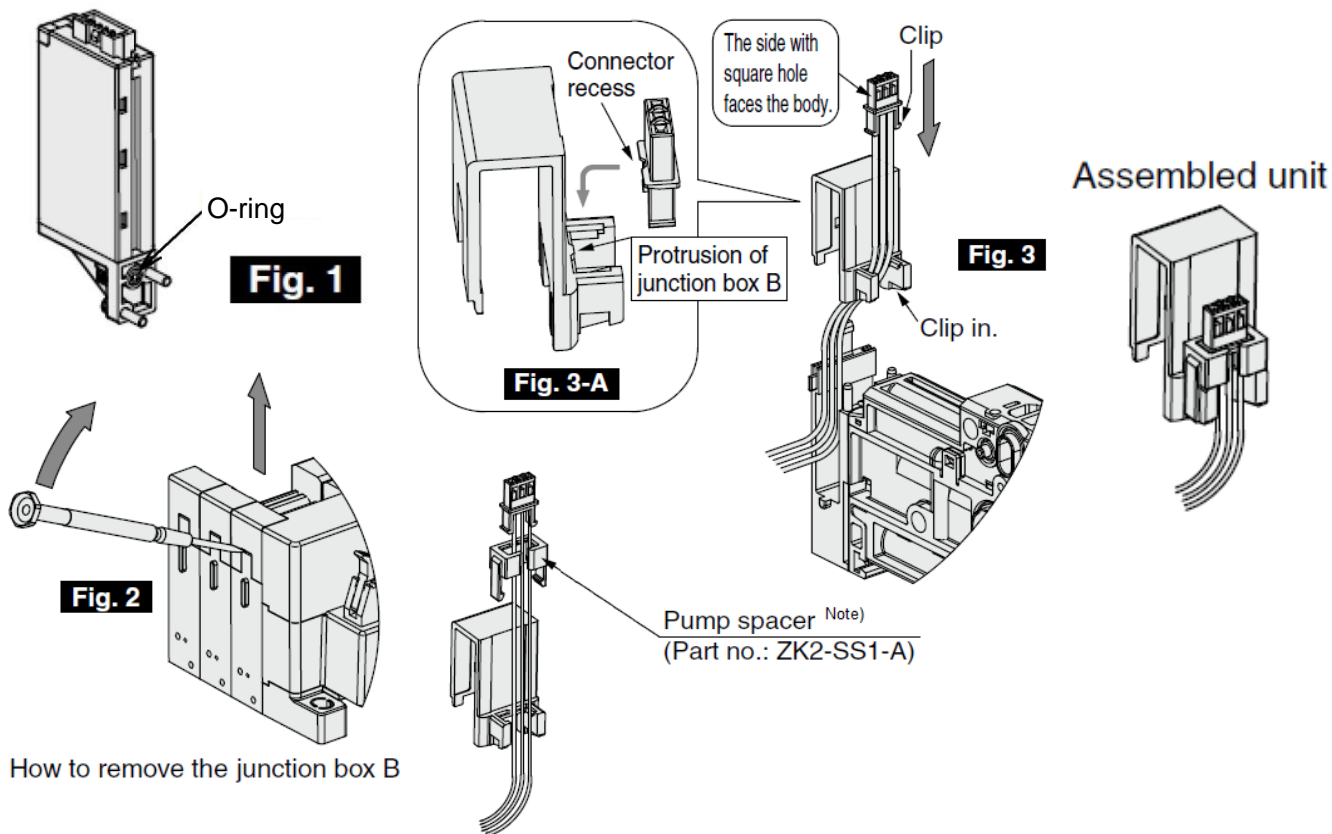

Note) When adding a vacuum pump system, the vacuum pump spacer for extra station is required separately.

■ To increase the number of stations from even number to odd number, or increase two stations or more

- 1) Remove the valve assembly for all stations. (Single unit for extra station is also removed.)
- 2) Remove the switch assembly if it is present. (Be careful not to drop the O-ring. Refer to Fig.1)
- 3) Remove the junction box B (top) for all stations using a precision screwdriver. (Refer to Fig.2)
(Remove the junction box B from D side.)
- 4) Remove all connectors mounted to the junction box B. (Be careful not to break the connector clip.)
- 5) Remove the tension bolt.
- 6) Remove the end plate D assembly.
- 7) Remove the connector housing assembly from the end plate D assembly. (Refer to Fig.4)
- 8) Mount the connector housing assembly for extra station(s) to the end plate D assembly. (Refer to Fig.4)
(Insert two clips of the housing mounting surface to the square holes of the end plate, and slide the connector housing assembly.)
- 9) Remove the end plate U. (Be careful not to drop the gasket.)
- 10) Mount a single unit for extra station(s) for manifold to the end surface of U side. Do not let the gasket get caught.
- 11) Mount the end plate U and D with the appropriate length of tension bolts for the number of stations required.
(Tightening torque: 0.75 Nm.)

- 12) Mount the connector for all stations to the junction box B. (Refer to Fig.3)
(Engage the recess of the connector and the protrusion of the junction box B. (Refer to Fig3-A))
- 13) Mount the junction box B to the junction box A. Push the wires down the side and mount the junction box B to the junction box A following a decreasing mark tube numbers from U side.
(Do not let the lead wire get caught.)
- 14) Assemble the valve assembly. (Tightening torque: 0.15 Nm)
- 15) For products with a switch, mount the switch assembly.
(Be careful not to drop the O-ring. Tightening torque: 0.08 to 0.10 Nm)

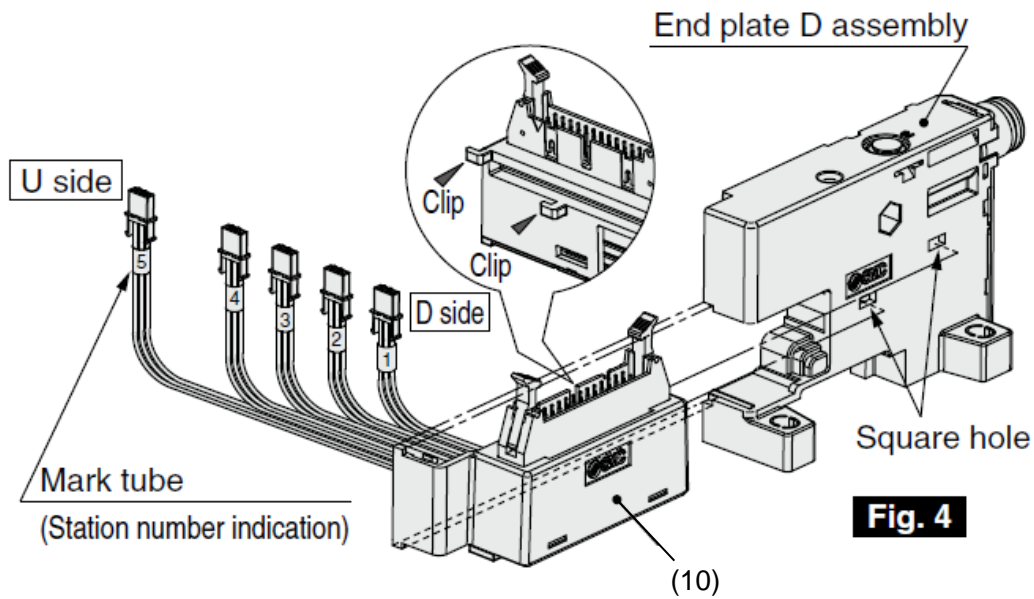

Fig. 4

7.3. Component Parts

No.	Item	Material	Remarks
1	End plate D assembly	PBT	HNBR, NBR and steel are also used
2	End plate U assembly	PBT	Electroless nickel plated brass, steel and NBR are also used

7.4. Replacement Parts

No.	Item	Remarks
3	Tension bolt assembly	2 pcs. per set
4	Port plug assembly	Plug for changing PV port to single side supply type (Common for mm and inch type)
5	Port plug assembly	Plug for changing PS or PD port to single side supply type (Common for mm and inch type)
6	One-touch fitting assembly	Metric size: ø8, Inch size: ø5/16"
7	Sound absorbing material	2 pcs. per set - Material: Non-woven cloth (Silencer cover is not included.)
8	DIN rail mounting bracket	1 piece for U side and D side
9	DIN rail	Refer to Dimensions in the Catalog for the recommended length for each number of manifolds stations.
10	Connector housing assembly	Available connector is even number only. (If you need a connector for odd number, specify the connector of the number you need +1 station.)

Note) When ordering a manifold “ZZK2□A-□□□□-A” on [page 12](#), 1 to 3 are delivered as a set.

7.5. Replacement Parts for Manifold/How to Order

(3) Tension bolt assembly

(2 pcs. per set)

ZK2-TB1-05-A

● Applicable stations

01	For 1 station manifold
⋮	⋮
10	For 10 stations manifold

(4) Port plug assembly

(Purchasing order is available in units of 1 piece.)

VVQZ2000-CP

(5) Port plug assembly

(Purchasing order is available in units of 1 piece.)

ZK2-MP1C6-A

- (6) One-touch fitting assembly
(Purchasing order is available in units of 10 pieces.)

VVQ1000-51A- C8

● Port size

C8	ø8 One-touch fitting
N9	ø5/16" One-touch fitting

- (7) Sound absorbing material
(2 pcs. per set)

ZK2-SE2-1-A

- (8) DIN rail mounting bracket (2pcs. for end plates U and D)

ZK2-DA4-A

Mounting of DIN rail bracket

- 1) Mount the DIN rail bracket to each end plate (Note 1).
- 2) Fix the DIN rail bracket using the mounting screws included in the package (tightening torque 0.35Nm).
- 3) Mount the bracket to the DIN rail. Refer to Page 17 for installation.

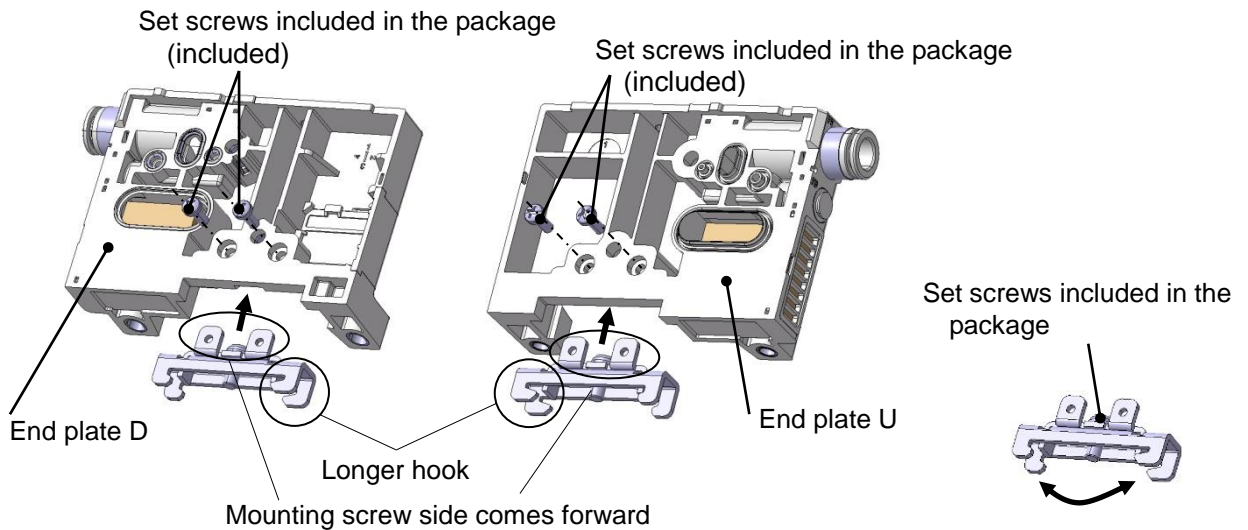

Note 1 : The direction of the DIN rail bracket can be changed by loosening the hook.

(9) DIN rail

AXT100-DR - 5

● Length symbols

1 to 40

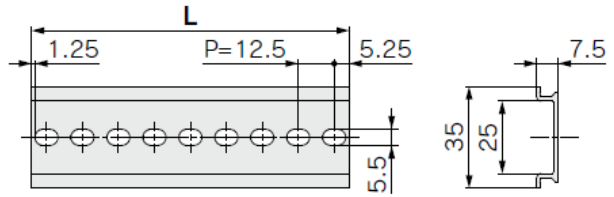

$$L = 12.5 \times \# + 10.5 \text{ (\#: Length symbols 1 to 40)}$$

L Dimension

(When selecting the number, refer to "L6" in dimension table in the Best Pneumatics No.4 catalog.)

No.	1	2	3	4	5	6	7	8	9	10
L Dimension	23	35.5	48	60.5	73	85.5	98	110.5	123	135.5

No.	11	12	13	14	15	16	17	18	19	20
L Dimension	148	160.5	173	185.5	198	210.5	223	235.5	248	260.5

No.	21	22	23	24	25	26	27	28	29	30
L Dimension	273	285.5	298	310.5	323	335.5	348	360.5	373	385.5

No.	31	32	33	34	35	36	37	38	39	40
L Dimension	398	410.5	423	435.5	448	460.5	473	485.5	498	510.5

(10) Connector housing assembly

ZK2-CH 2 04 -A

● Connector type

1	D-sub connector (25 pins)
2	Flat ribbon cable connector (26 pins)

● Applicable stations

02	For 2 stations manifold
04	For 4 stations manifold
06	For 6 stations manifold
08	For 8 stations manifold
10	For 10 stations manifold

■ Plug (For One-touch fitting)

(Purchasing order is available in units of 10 pieces.)

Mounted onto ports which are not used (PV, PS, PD, etc.)

KQ2P-06

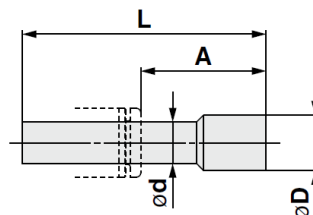
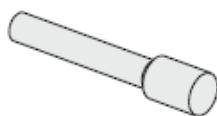

● Model and Dimensions

Symbol	Applicable size ød	A	L	øD	Weight (g)	Note
06	ø6	18	35	8	1	White
08	ø8	20.5	39	10	2	White
07	ø1/4"	18	35	8.5	1	Orange
09	ø5/16"	20.5	39	10	2	Orange

When existing product is used, please be careful with the interchangeability between existing product in the table below and ZK2□A.

○Single unit

New valve assembly of ZK2□A cannot be assembled with the existing products.

(Pilot valve dimension and valve body dimension are different)

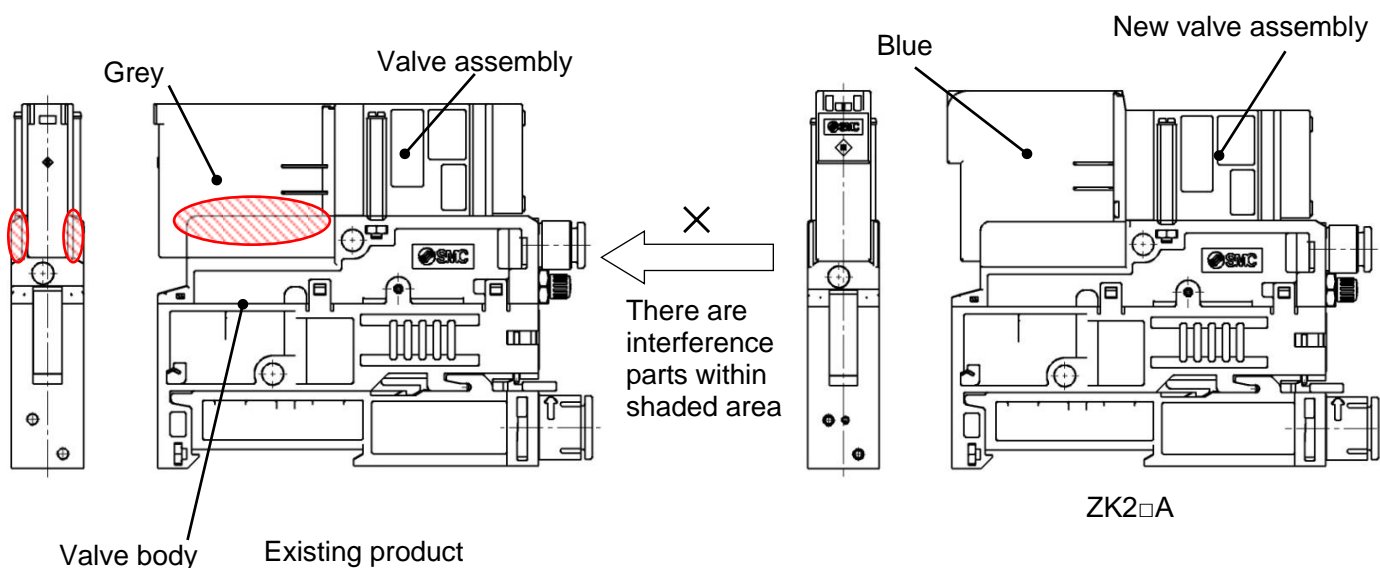

○Manifold of more than 3 stations.

Single unit of ZK2□A for manifold cannot be assembled with the existing manifold. (Pilot valve dimension and end plate dimension are different).

By replacing the manifold end plate assembly with the manifold end plate for ZK2□A, a single unit of ZK2□A for manifold can be assembled. Manifold end plate assembly number (see [Page 12](#)).

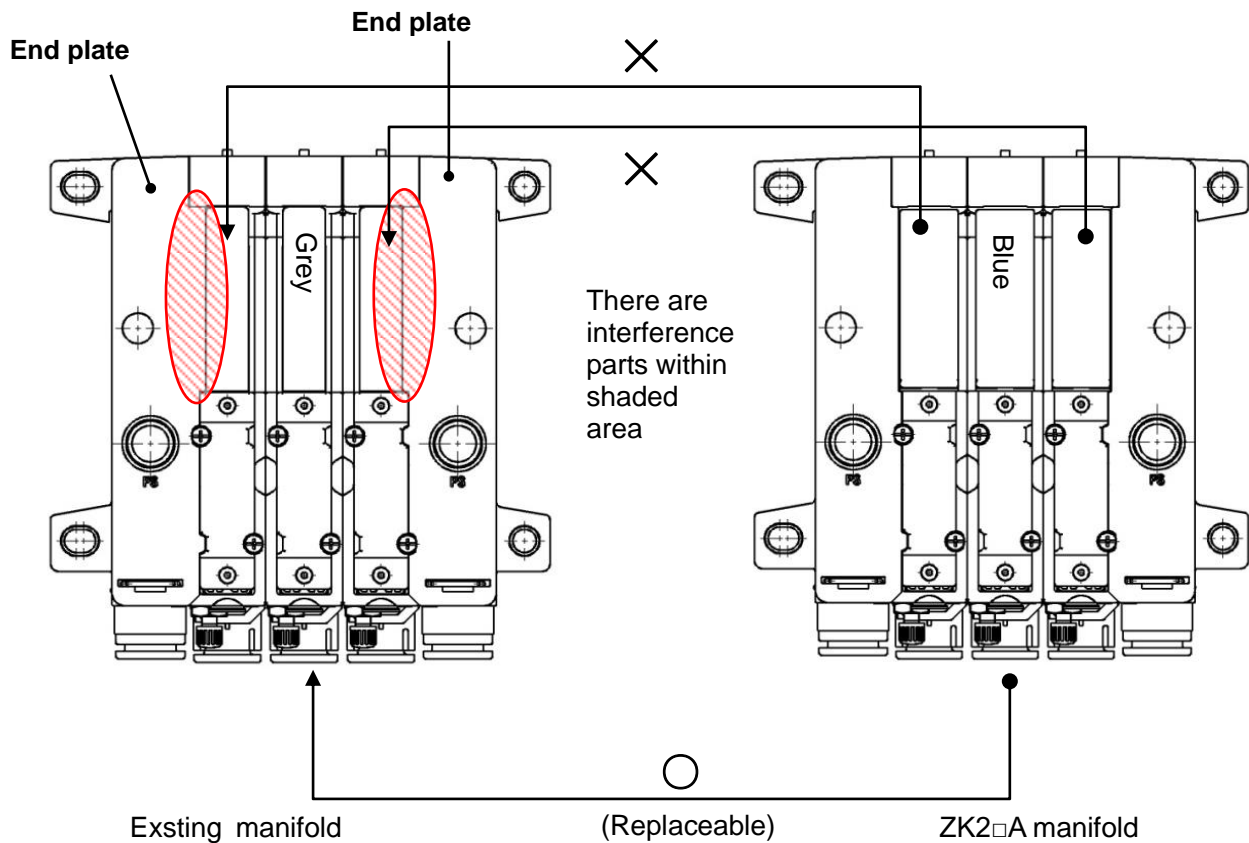

- Manifold of 1 or 2 stations.

A single unit ZK2□A for manifold cannot be assembled with the existing manifold.

(Pilot valve dimension and end plate dimension are different)

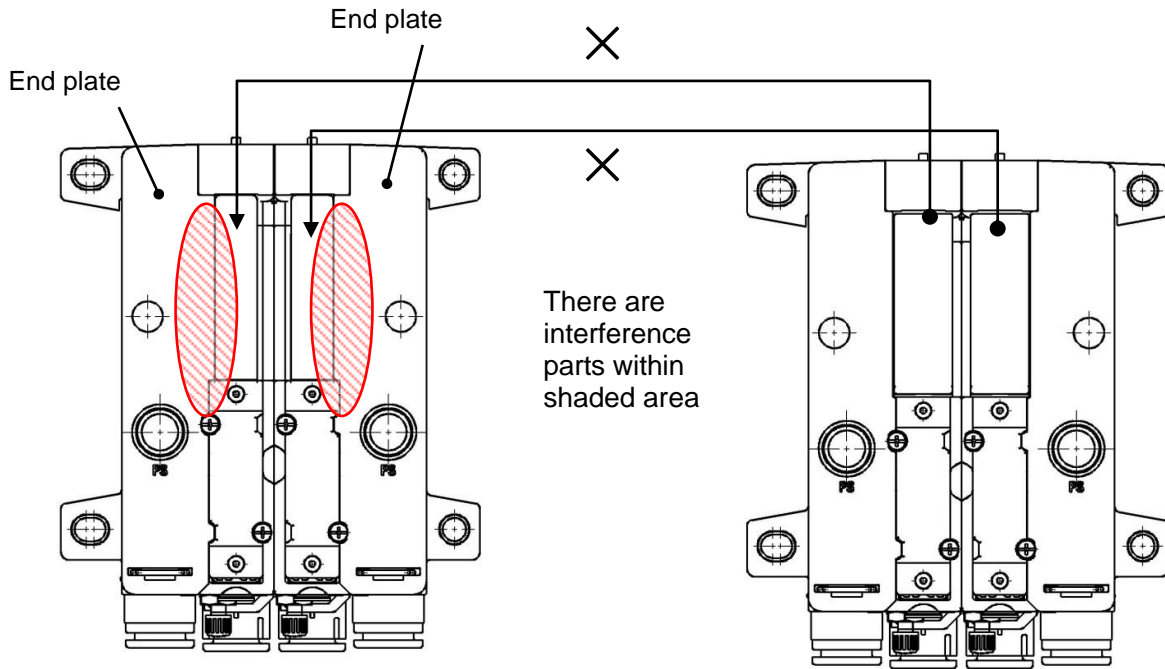

Existing Manifold

ZK2□A Manifold

- Replacement of the check valve

The ZK2□A body gasket (integrated with the check valve) cannot be mounted to the existing product.

The check valve and the body gasket are separate parts for the conventional product, but ZK2□A is not interchangeable because it is integrated.

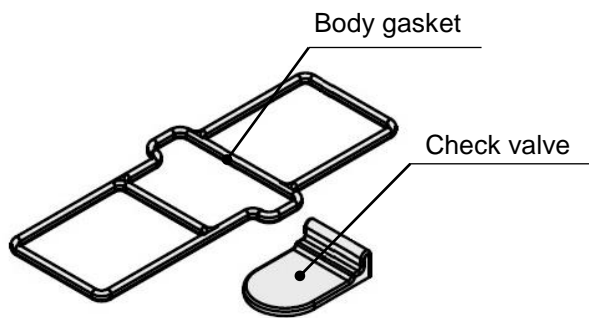

Current product Body gasket and check valve

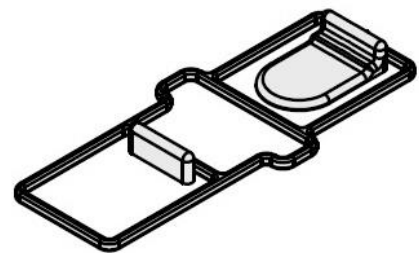

ZK2□A Body gasket

○Mounting the new product to the existing manifold

When the manifold consists of one or 2 stations of the existing valve, or if the 1st or last station need to be replaced, please replace entire manifold to the new product series.

No change in the position of the hole for mounting the end plate. For common wiring (D-sub connector, flat cable), wiring does not need to be changed. Only the end plate needs to be replaced.

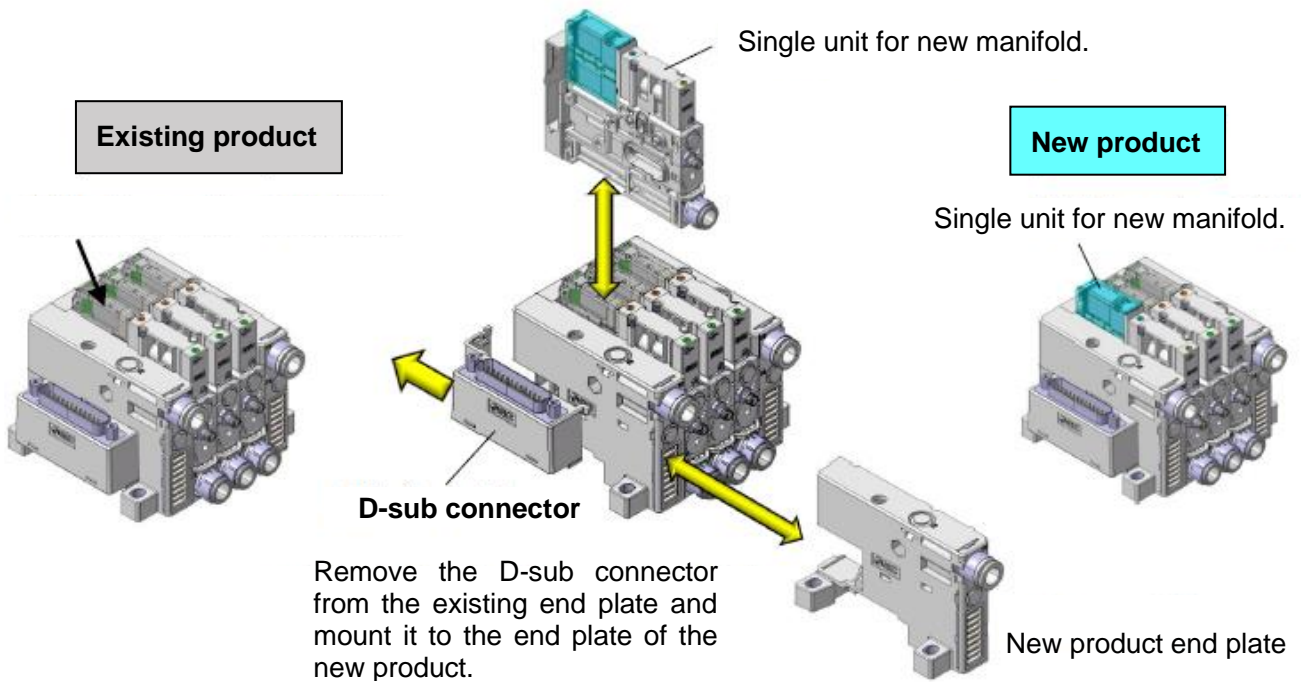

If anything is unclear about the end plate product number, contact your nearest sales office.

8. Maintenance

8.1. Maintenance

Implement the maintenance and check shown below in order to use the ejector and the vacuum pump system safely and in an appropriate way for a long period of time.

1) Maintenance should be performed according to the procedure indicated in the Operation Manual. Improper handling can cause damage and malfunction of equipment and machinery.

2) Maintenance work

Compressed air can be dangerous when handled incorrectly. Therefore, in addition to observing the product specifications, replacement of elements and other maintenance activities should be performed by personnel with sufficient knowledge and experience pertaining to pneumatic equipment.

3) Draining

Remove condensate from air filters and mist separators regularly. If the collected drainage is drained to the downstream side, it can stick inside of the product, causing operation failure and failure to reach the specified vacuum pressure.

4) Replace the filter element built into the ejector and the vacuum pump system and the silencer regularly. (Refer to the replacement procedure below.)

It is recommended to replace the filter element and the silencer when the pressure drop reaches 5kPa as a guideline. The replacement cycle varies depending on the operating conditions, operating environment and supply air quality.

However, if there is a vacuum pressure drop and/or delay in the vacuum (adsorption) response time which causes problem with the settings during operation, stop the operation of the product and replace the element regardless of the above mentioned replacement guideline.

5) Operation in an environment where there is a lot of dust in the air

The processing capacity of the filter element built into the product may be insufficient. It is recommended to use SMC's air suction filter (ZFA, ZFB, ZFC series) in order to avoid problems beforehand.

6) Check before and after the maintenance work

When the product is to be removed, turn off the power supply, and be sure to cut off the supply pressure and exhaust the compressed air. Confirm that the air is released to atmosphere.

When mounting the product after the maintenance work, supply compressed air, connect to the power, check if it functions properly and have a leakage inspection. Especially for valve type R, be sure to check that the supply valve is OFF in the initial condition because it is possible that it is ON due to vibration.

7) Do not disassemble or modify the product, other than the replacement parts specified in this manual.

8) Tighten to the specified tightening torque.

If the tightening torque is exceeded, the product, the mounting screws, brackets and the pressure switch can be broken. Insufficient torque can cause displacement of the product and the pressure switch from each proper position and loosening of the mounting screws.

- 9) Be sure to ground the frame ground (FG) terminal when using a commercially available switching power supply.
- 10) Eliminate any dust left in the piping by using a blast of air before connecting the piping to the product. Otherwise, failure or malfunction may occur.
- 11) If the fluid contains foreign matter, install and connect a filter or mist separator to the inlet. Otherwise, failure, malfunction or inaccurate measurements from the pressure switch may occur.

8.2. Replacement Procedure

8.2.1. Replacement procedure for filter element

- 1) To pull out the vacuum port adapter, rotate the adapter by about 90 degrees in direction A and pull in direction B. The adapter can be removed with the suction filter from the filter case.
- 2) Remove the suction filter from the vacuum port adapter and replace it with a new suction filter.

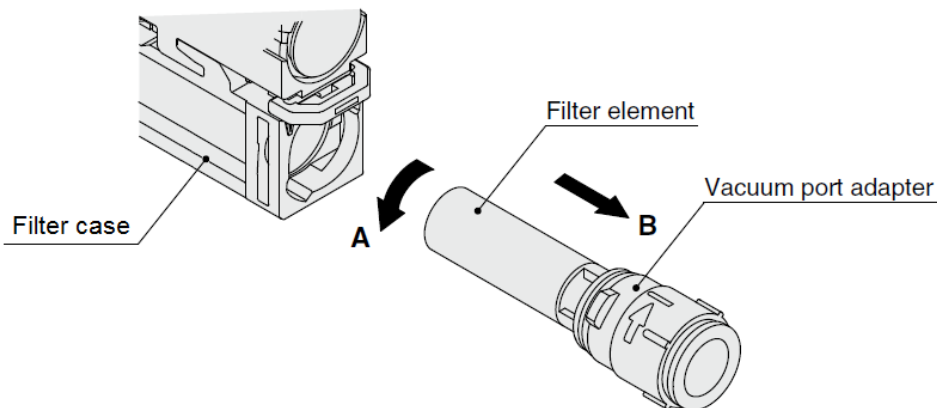

- 3) When installing the filter, insert the filter to the end so that there is no gap or bending between the filter and the vacuum port adapter. The gap or bending will cause the element to deform inside the case.

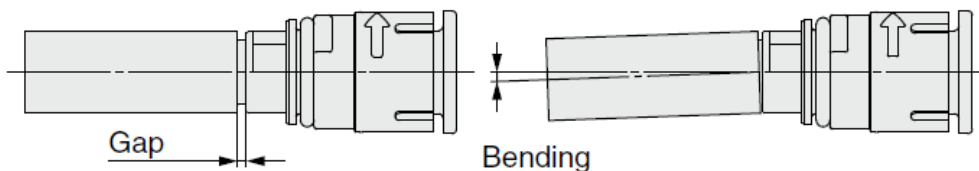

4) Put the filter back into the filter case following this procedure in reverse.

To mount the vacuum port adapter into the filter case, turn the adapter so that the mating mark of the adapter and the case are aligned. (Rotation stops there.)

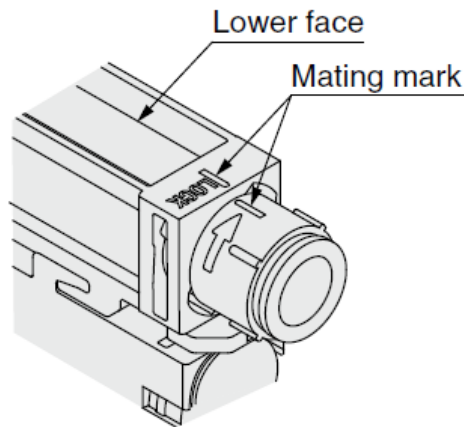

If it is difficult to remove the vacuum port adapter, you can remove the adapter with a hexagon wrench using the hexagonal hole in V port. The table shows the port size and the width across flats.

V port size	Width across flats
ø6	4
ø8, ø5/16"	6
ø1/4"	4.76

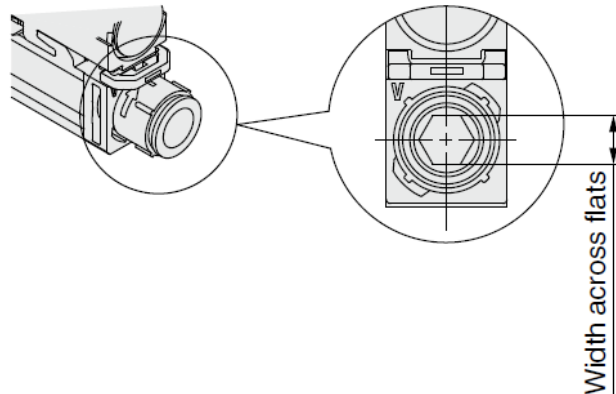

8.2.2. Replacement procedure for Sound Absorbing Material (for Silencer Exhaust)

- 1) Remove the filter case. Refer to Filter case maintenance on [page 53](#).
- 2) Flip the ejector, push the release lever again with a finger or precision screwdriver until the release lever stops.

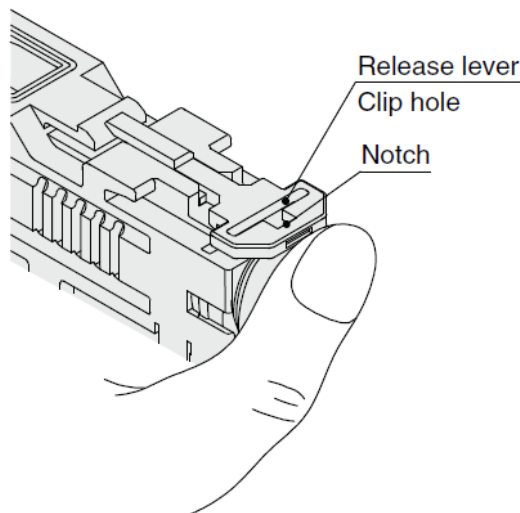

- 3) To remove the clip that holds the port plug, insert a precision screwdriver from the release lever notch. Move the screwdriver in direction (1) to pull out the clip in direction (2).

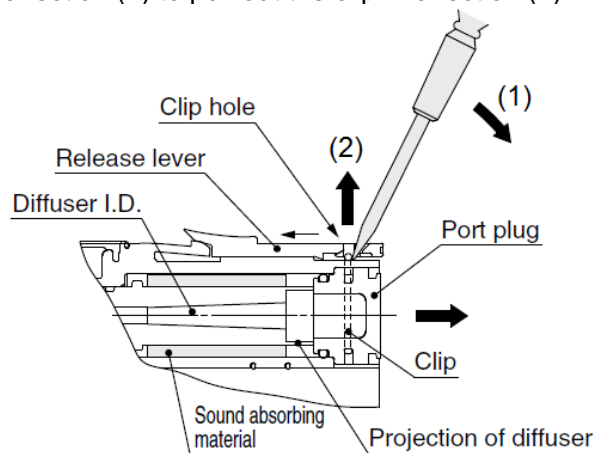

- 4) Remove the port plug. Slide back the release lever.
 5) Remove the sound absorbing material from the slit (hole) at the side of the body by using a precision screwdriver.
 6) Insert the new sound absorbing material. Be careful not to scratch the material with the projection of the diffuser assembly.

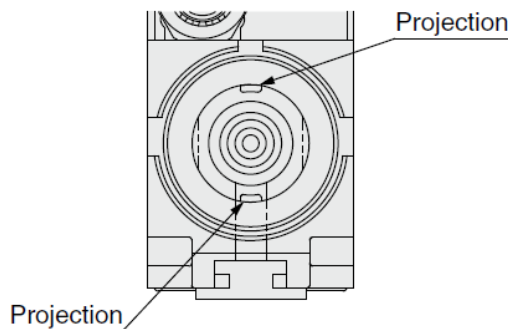

Diffuser hole viewed from the port plug

(Procedure to put parts back together)

- 7) Insert the port plug and insert the clip into the groove using the lever hole. (Push completely to the end.)
 8) Push the release lever until it stops in direction (3).

Note) Do not pull or bend the two projections at the end surface of the diffuser. These are spacers to prevent the displacement of the diffuser and they may break if force is applied.

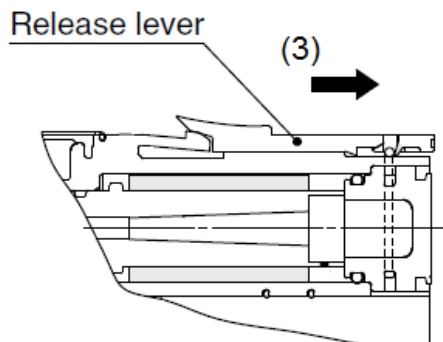

8.2.3. Replacement procedure for High-noise Reduction Silencer Assembly

Refer to Replacement procedure for Sound Absorbing Material (for Silencer Exhaust) on [page 50](#) to replace the assembly.

Note) When a high-noise reduction silencer assembly is attached to System/Body Type "A" (silencer exhaust), the silencing effect cannot be acquired.

When only replacing the Sound Absorbing Material (for High-noise Reduction Silencer exhaust)

- 1) Use the notch to remove the cap.
- 2) Use a precision screwdriver to remove the sound absorbing material.
- 3) Insert the new sound absorbing material, and return the cap.

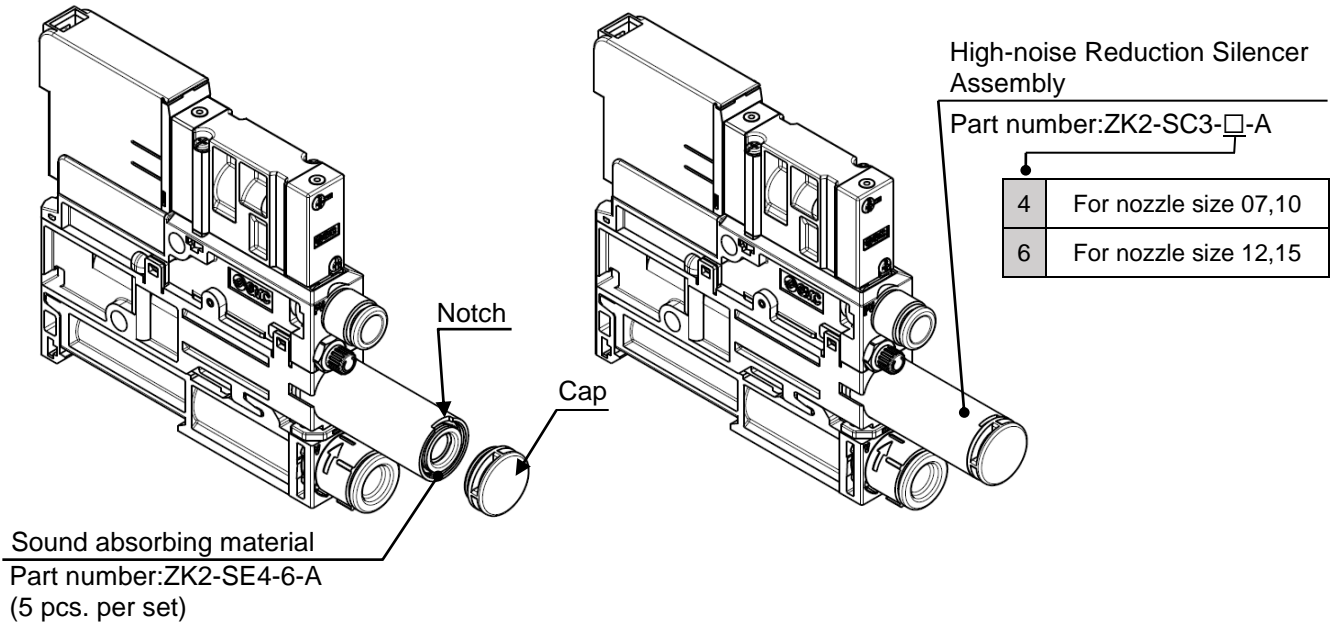

8.2.4. Replacement procedure for Manifold Sound Absorbing Material.

- 1) Insert a precision screwdriver to notch (A) of the end plate and remove a clip (L) (1).
- 2) Insert a precision screwdriver to notch (B) and remove the silencer cover (2).
- 3) Pull out the sound absorbing material from the silencer cover (3).
- 4) Mounting of a new sound absorbing material should be performed by following the removal procedure in reverse.

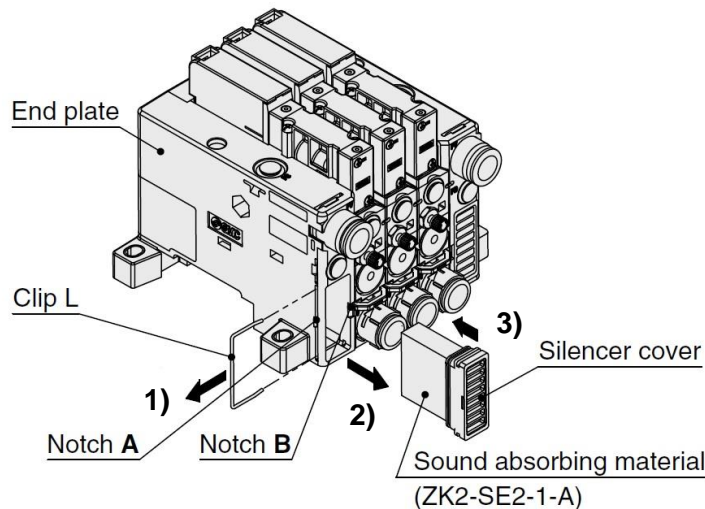

Ejector system manifold silencer common exhaust type has a sound absorbing material in the end plate. If the sound absorbing material is clogged, ejector performance is deteriorated, leading to suction failure or response delay. Regular replacement of the sound absorbing material is recommended.

8.2.5. Filter case maintenance

1) When the filter case is dirty, it can be removed and cleaned.

To remove the filter case, insert a precision screwdriver into the groove of the release lever and push in direction (1), and slide the filter case in direction (2).

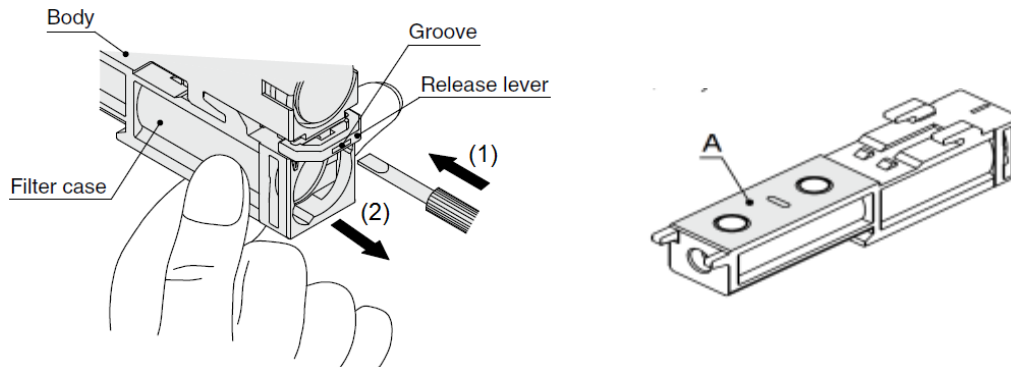

Note 1) Surface A of the filter case is the sealing surface when vacuum is generated. Handle with care so that the surface is not scratched or damaged.

Note 2) Filter case is made of polycarbonate. Avoid chemicals such as thinner, carbon tetrachloride, chloroform, acetic ester, aniline, cyclohexane, trichloroethylene, sulfuric acid, lactic acid, water base cutting fluid (alkaline).

Note 3) Do not expose the filter case to direct sunlight for a long period of time.

(Procedure to put parts back together)

2) Make sure that the body gasket that matches the product specifications is installed correctly onto the ejector. If they are out of the place, vacuum leakage may occur.

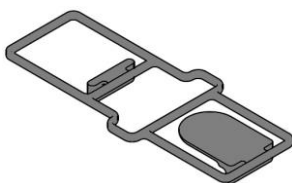
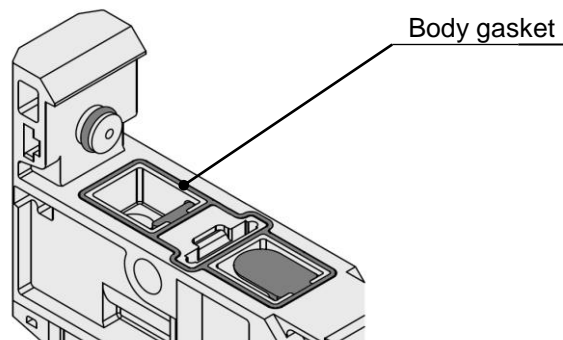

One check valve type

(All specifications other than vacuum switch with energy saving function and exhaust interference prevention valve)

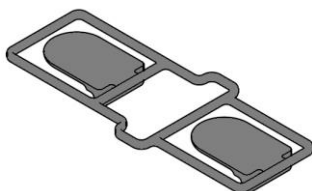

Two check valve type

(Vacuum switch with energy saving function and exhaust interference prevention valve)

- 3) Push the filter case in direction (1). Be careful the filter case hook (A) and hook (B) do not touch the body of the ejector.
- 4) Slide the filter case in direction (2) while pushing the filter case gently in contact with the ejector. Make sure that the clip (C) is locked and there is no gap in part (D).

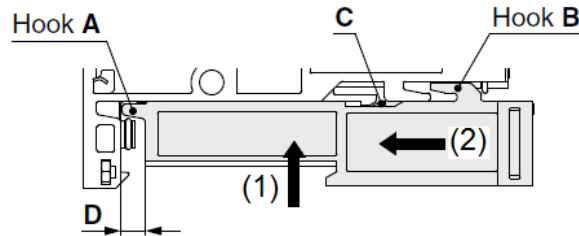

Note 4) If excess force is applied to the filter case, hook A and B may break. Handle with care.

9. Specifications

■ General Specifications

Ambient temperature range (No condensation)	-5 to 50°C (Without pressure sensor and pressure switch, With pressure switch, With pressure switch with energy saving function) 0 to 50°C (With pressure sensor)
Fluid	Air
Vibration resistance ^{Note 1)}	30m/s ² (Without pressure sensor and pressure switch, With pressure sensor) 20m/s ² (With pressure switch)
Impact resistance ^{Note 2,3)}	150m/s ² (Without pressure sensor and pressure switch, With pressure sensor) 100m/s ² (With pressure switch)
Standard	CE, RoHS

Note 1) The characteristics are satisfied when tested for 2 hours in each of the X, Y and Z directions at 10 to 500 Hz without energization. (Initial value)

Note 2) The characteristics are satisfied when tested one time in each of the X, Y and Z directions without energization. (Initial value)

Note 3) For valve type R (Self-holding release valve linked), impact resistance is 50m/s².

■ Valve Common Specifications

Valve model ^{Note 4)}	ZK2-VA□K□□A	ZK2-VA□R□□A	ZK2-VA□J□□A
Type of Actuation ^{Note 5)}	Supply valve: N.C. Release valve: N.C.	Supply valve: Self-holding release valve linked Release valve: N.C.	Supply valve: N.C. Release valve: None
Valve configuration	Pilot operated dual 2 port		Pilot operated 2 port
Operating pressure range	0.3 to 0.6 MPa		
Valve construction	Poppet seal		
Manual override	Push type		
Rated voltage	24 VDC, 12VDC		
Power consumption	0.35W		
Lead wire (ZK2-LV-□□-A)	Conductor cross section: 0.2 mm ² (AWG24)		
	Insulator O.D.: 1.4 mm		

Note 4) Refer to Valve assembly on [page 33](#) for the valve model number.

Note 5) ZK2-VA□R: When the supply valve is energized (20 ms or more), the supply valve keep ON position even after energization is stopped. When release valve is energized, the supply valve is turned off in conjunction with the operation of the release valve.

ZK2-VA□K: Supply valve turns off when is not energized. Select this type when pressure switch with energy saving function is used.

■ Noise Level (Reference values)

Model		ZK2□07	ZK2□10	ZK2□12	ZK2□15
Noise level [dB(A)]	ZK2G (High-noise reduction silencer exhaust)	46	55	63	69
	ZK2A (Silencer exhaust)	59	66	75	76

Ejector Specifications

Model		ZK2□07	ZK2□10	ZK2□12	ZK2□15	
Nozzle diameter	(mm)	0.7	1.0	1.2	1.5	
Max. suction flow ^{Note 6)}	Port exhaust	(L/min(ANR))	34	56	74	89
	Silencer exhaust/Complex exhaust	(L/min(ANR))	29	44	61	67
	High-noise reduction silencer exhaust	(L/min(ANR))	34	56	72	83
Air consumption ^{Note 6)}	(L/min(ANR))	24	40	58	90	
Max. vacuum pressure ^{Note 6)}	(kPa)	-91				
Supply pressure range ^{Note 7)}	(MPa)	0.3 to 0.6 (0.1 to 0.6)				
Standard supply pressure ^{Note 8)}	(MPa)	0.35			0.4(0.37)	

Note 6) Values at the standard supply pressure. Values are based on standard of SMC measurements. They depend on atmospheric pressure (weather, altitude, etc.) and measurement method.

Note 7) The value in () is for without valve.

Note 8) The value in () is for without valve. For nozzle size 07 to 12, the value is common to the ejectors with valve and without valve.

Suction Filter Specifications

Filtration rating	30 μm
Filtration area	510 mm ²

Pressure Sensor specifications

(For details, refer to the PSE series in the Best Pneumatics No. 8 catalog, and the Operation Manual.)

Model (Sensing unit: Standard model number)		ZK2-PS1-A (PSE541)	ZK2-PS3-A (PSE543)
Rated pressure range		0 to -101 kPa	-100 to 100 kPa
Proof pressure		500 kPa	
Output voltage		1 to 5 VDC	
Output impedance		Approx. 1 kΩ	
Power supply voltage		12 to 24 VDC ±10%, Ripple (p-p) 10% or less	
Current consumption		15 mA or less	
Accuracy		±2% F.S. (Ambient temperature at 25 °C)	
Linearity		±0.4% F.S.	
Repeatability		±0.2% F.S.	
Effect of power supply voltage		±0.8% F.S.	
Environmental resistance	Ambient temperature	Storage: -20 to 70 °C (No condensation or freezing)	
	Ambient humidity	Operation, Storage: 35 to 85% RH (No condensation)	
Temperature characteristics		±2% F.S. (Ambient temperature: 25 °C reference)	
Material	Case	Resin case: PBT	
	Pressure sensing section	Sensor pressure receiving area: Silicone, O-ring: HNBR	
Lead wire		Oilproof heavy-duty vinyl cable, 3 wires, Oval 2.7 x 3.2 mm, 3 m Conductor cross section 0.15 mm ² , insulator O.D.: 0.9 mm	

■ Pressure Switch for Vacuum

(For details, refer to the ZSE10/ISE10 series in the Best Pneumatics No. 8 catalog, and the Operation Manual.)

Model (Switch unit: Standard model number)		ZK2-ZSE□□□-A (ZSE10)	ZK2-ZSF□□□-A (ZSE10F)
Rated pressure range		0 to -101 kPa	-100 to 100 kPa
Set/Display pressure range		10 to -105 kPa	-105 to 105 kPa
Proof pressure		500 kPa	
Minimum setting unit		0.1 kPa	
Power supply voltage		12 to 24 VDC ±10%, Ripple (P-P) 10% or less (Protected against reverse connection)	
Current consumption		40 mA or less	
Switch output	Output type	NPN or PNP open collector 2 outputs (To be selected)	
	Maximum load current	80 mA	
	Maximum applied voltage	28 V (NPN output)	
	Residual voltage	2 V or less (at 80 mA load current)	
	Response time	2.5 ms or less (response time available for anti-chattering function: 20, 100, 500, 1000 or 2000 ms)	
	Short circuit protection	Provided	
Repeatability		±0.2% F.S. ±1 digit	
Hysteresis	Hysteresis mode	Variable from 0 ^{Note 9)}	
	Window comparator mode		
Display type		3 1/2 digits, 7-segment LED 1-color display (Red)	
Display accuracy		±2% F.S. ±1 digit (at ambient temperature 25 ± 3 °C)	
Indication LED		Lights up when output is turned on. OUT1: Green, OUT2: Red.	
Environmental resistance	Enclosure	IP40	
	Ambient temperature	Storage: -10 to 60 °C (No condensation or freezing)	
	Ambient humidity	Operation, Storage: 35 to 85% RH (No condensation)	
	Withstand voltage	1000 VAC for 1 minute between terminals and housing	
	Insulation resistance	50 MΩ or more between terminals and housing (with 500 VDC megger)	
Temperature characteristics		±2% F.S. (Ambient temperature: 25 °C reference)	
Lead wire		Oilproof heavy-duty vinyl cable, 5 wires, ø3.5, 2m Conductor cross section 0.15 mm ² (AWG26), insulator O.D.: 1.0mm	

Note 9) If the applied pressure fluctuates around the set value, the hysteresis must be set to a value more than the fluctuating width. Otherwise, chattering will occur.

■ Pressure Switch for Vacuum with energy saving function

(For details, refer to the ZK2-ZSV□□□-A Operation Manual.)

Model		ZK2-ZSV□□□-A
Rated pressure range		-100 to 100 kPa
Set/Display pressure range		-105 to 105 kPa
Proof pressure		500 kPa
Minimum setting unit		0.1 kPa
Power supply voltage		12 to 24 VDC $\pm 10\%$, Ripple (P-P) 10% or less (Protected against reverse connection)
Current consumption		40 mA or less
Switch output	Output type	NPN or PNP open collector OUT1: General purpose, OUT2: Valve control
	Maximum load current	80 mA
	Maximum applied voltage	26.4 VDC
	Residual voltage	2 V or less (at 80 mA load current)
	Response time	2.5 ms or less (response time available for anti-chattering function: 20, 100, 500, 1000 or 2000 ms)
	Short circuit protection	Provided
Repeatability		$\pm 0.2\%$ F.S. ± 1 digit
Hysteresis	Hysteresis mode	Variable from 0 ^{Note 10)}
Display type		3 1/2 digits, 7-segment LED 1-color display (Red)
Display accuracy		$\pm 2\%$ F.S. ± 1 digit (at ambient temperature 25 ± 3 °C)
Indication LED		Lights up when output is turned on. OUT1: Green, OUT2: Red.
Environmental resistance	Enclosure	IP40
	Operating temperature range	-5 to 50°C
	Withstand voltage	1000 VAC for 1 minute between terminals and housing
	Insulation resistance	50M Ω or more between terminals and housing (with 500 VDC megger)
Temperature characteristics		$\pm 2\%$ F.S. (at 25°C in an operating temperature range of -5 and 50°C)
Lead wire		5 wires, $\phi 3.5$, 2m Conductor cross section 0.15 mm ² (AWG26), insulator O.D.: 1.0mm

Note 10) If the applied pressure fluctuates around the set value, the hysteresis must be set to a value more than the fluctuating width. Otherwise, chattering will occur.

■ Weight

Single Unit

Model of a single unit	Weight (g)
ZK2P00K□N□A (Vacuum pump, without pressure sensor and pressure switch)	97
ZK2A□K□N□A (Ejector, without pressure sensor and pressure switch)	95
ZK2A□N0NNA (Ejector, without valve)	54
ZK2C□K□N□A (Ejector for manifold, without pressure sensor and pressure switch)	99

Pressure Sensor, Pressure switch for vacuum

Model of pressure sensor and pressure switch for vacuum	Weight (g)
ZK2-PS□-A (Weight excluding the cable)	5
ZK2-ZS□-A (Weight excluding the lead wire assembly with connector)	14

Manifold Base

Stations	1	2	3	4	5	6	7	8	9	10
Weight (g)	129	132	135	138	141	144	147	149	152	155

Calculation of Weight for the Manifold Type

(Single unit weight x Number of stations)
 + (Pressure sensor/Pressure switch for vacuum weight x Number of stations)
 + Manifold base

Example: 5-station manifold with pressure sensor

$$99\text{g} \times 5\text{pcs.} + 5\text{g} \times 5\text{pcs.} + 141\text{g} = 661\text{g}$$

10. Port Layout

■ Standard products (No Option)

Port Layout No. 1

Port combination: PV ≠ PS = PD

Single unit: **ZK2P00**□□□□**A-**□

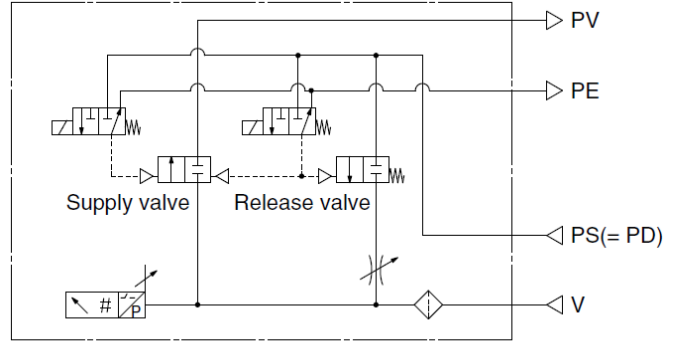
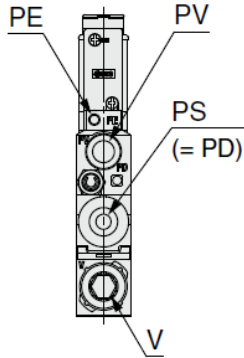

Supply valve: Self-holding type Release valve: N.C. (R type)

System	Vacuum pump	
Body type	Single unit	
Exhaust type	Without silencer	
Application and purpose	Vacuum pressure	-
	Exhaust	-
	Release pressure	Same pressure as PS

Port Layout No. 2

Port combination: Common PV ≠ Common PS = Common PD

Single unit: **ZK2Q00**□□□□**A-**□

Manifold: **ZZK2**□□**A-P2**□

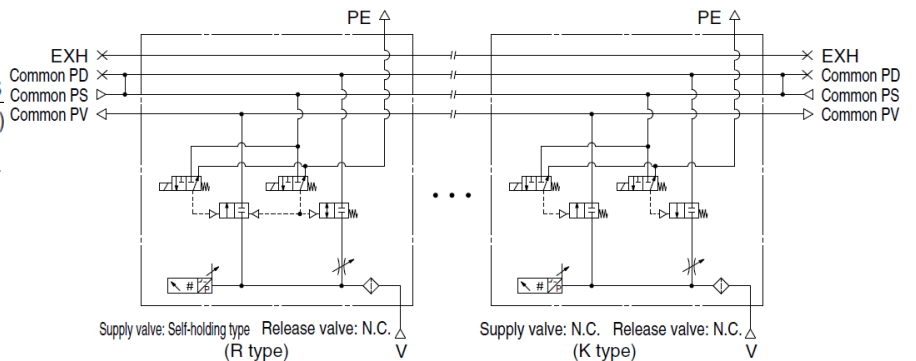
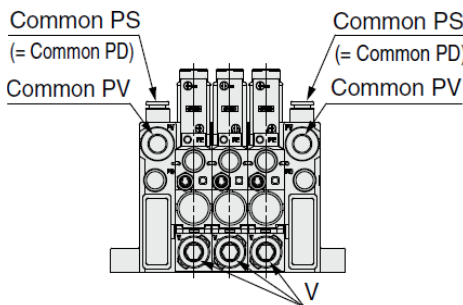

System	Vacuum pump	
Body type	Manifold	
Exhaust type	Without silencer	
Application and purpose	Vacuum pressure	Common for each station
	Exhaust	-
	Release pressure	Same pressure as common PS

Port Layout No. 3

Single unit: **ZK2A**□□□□□□**A**-□

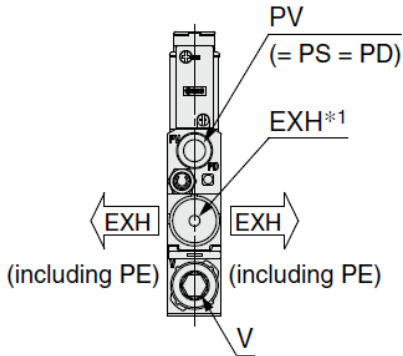

Port combination: PV = PS = PD

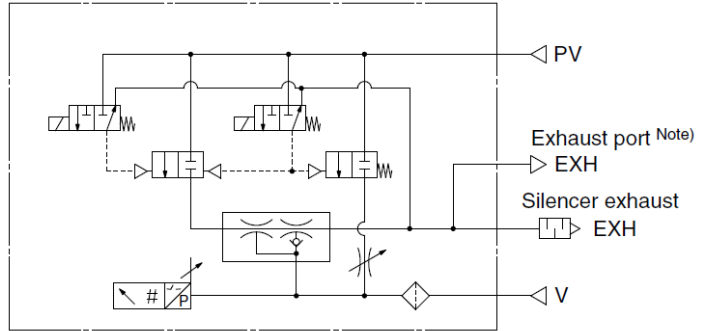

Supply valve: Self-holding type Release valve: N.C. (R type)

Note) Nozzle size: 12, 15

System	Ejector	
Body type	Single unit	
Exhaust type	Silencer exhaust	
Application and purpose	Vacuum pressure	-
	Exhaust	Released in operating environment
	Release pressure	Same pressure as PV

Port Layout No. 4

Single unit: **ZK2B**□□□□□□**A**-□

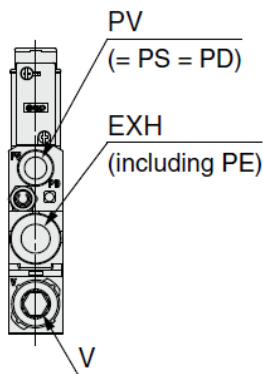

Port combination: PV = PS = PD

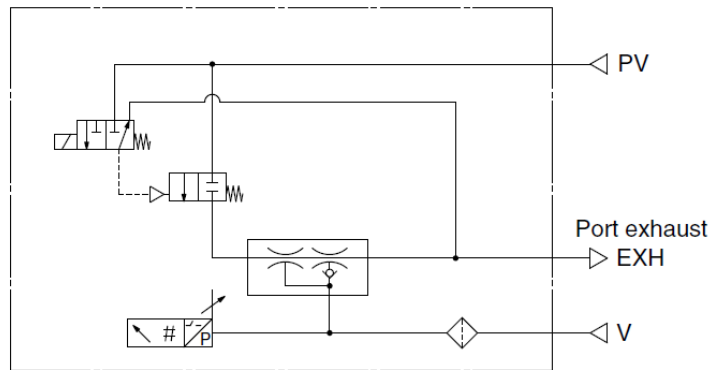

Supply valve: N.C. Release valve: Without release valve (J type)

System	Ejector	
Body type	Single unit	
Exhaust type	Port exhaust	
Application and purpose	Vacuum pressure	-
	Exhaust	After piping, individual exhaust is necessary.
	Release pressure	Same pressure as PV

Port Layout No. 5

Port combination: PV = PS = PD

Single unit: **ZK2G**□□□□□**A**-□

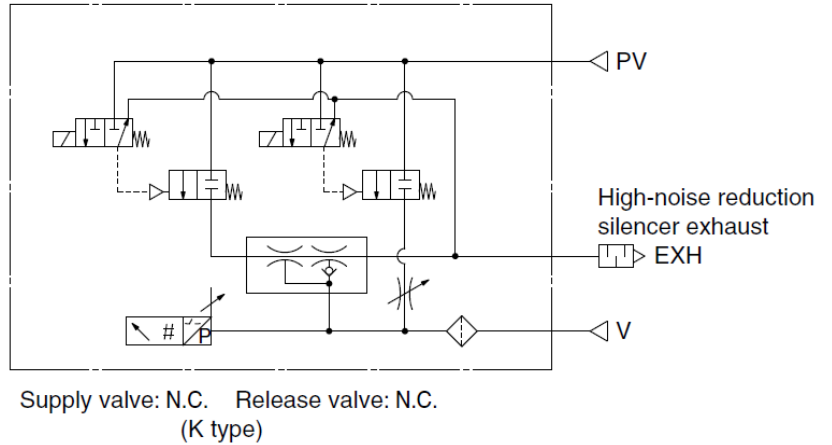
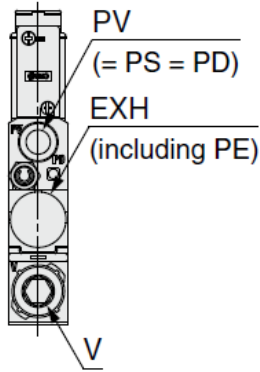

System	Ejector	
Body type	Single unit	
Exhaust type	High-noise reduction silencer exhaust	
Application and purpose	Vacuum pressure	-
	Exhaust	Released in operating environment
	Release pressure	Same pressure as PV

Port Layout No. 6

Port combination: Common PV = Common PS = Common PD

Single unit: **ZK2C**□□□□□□**A**-□

Manifold: **ZZK2**□□**A**-**A1**□

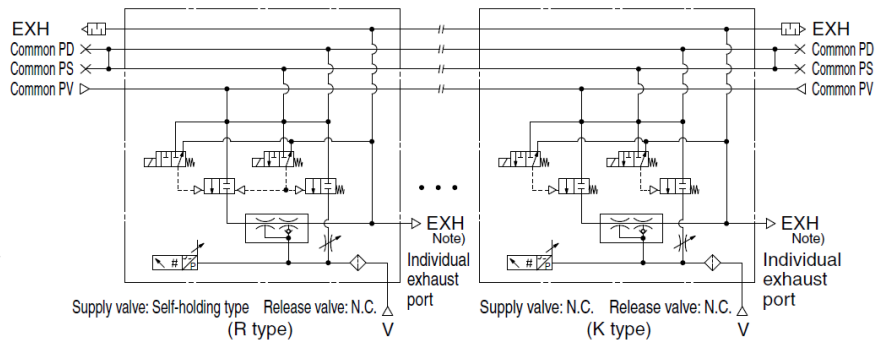
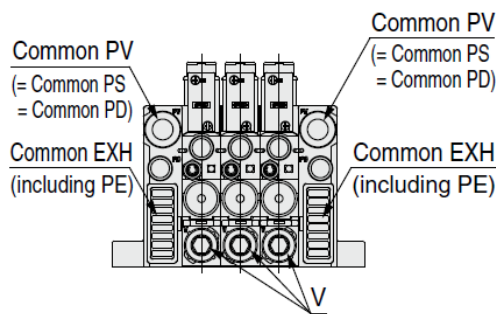

Note) For complex exhaust type, individual exhaust port is provided to each station.

System	Ejector	
Body type	Manifold	
Exhaust type	Complex exhaust	
Application and purpose	Vacuum pressure	Common for each station
	Exhaust	Released in operating environment
	Release pressure	Same pressure as common PV

Port
Layout No.

7

Port combination: Common PV = Common PS = Common PD

Single unit: ZK2F□□□□□A-□

Manifold: ZZK2□□A-A2□

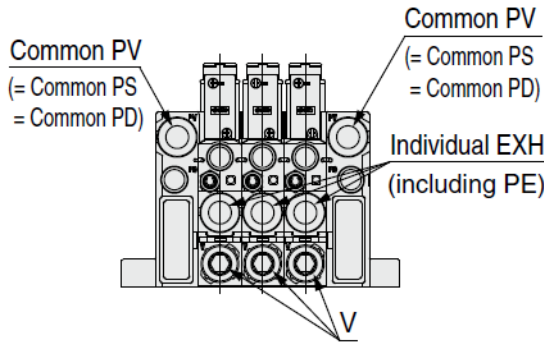

System		Ejector
Body type		Manifold
Exhaust type		Individual port exhaust
Application and purpose	Vacuum pressure	Common for each station
	Exhaust	After piping, individual exhaust is necessary.
	Release pressure	Same pressure as common PV

Port
Layout No.

8

Single unit: ZK2H□□□□□A-□ Port combination: Common PV = Common PS = Common PD

Manifold: ZZK2□□A-A2□

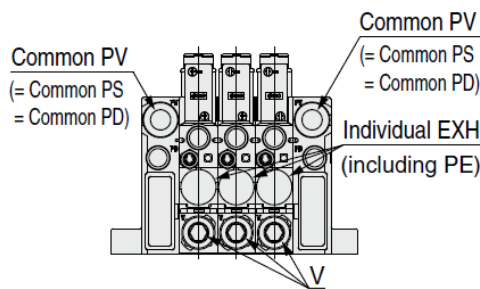

System		Ejector
Body type		Manifold
Exhaust type		High-noise reduction silencer exhaust
Application and purpose	Vacuum pressure	Common for each station
	Exhaust	Released in operating environment
	Release pressure	Same pressure as common PV

7

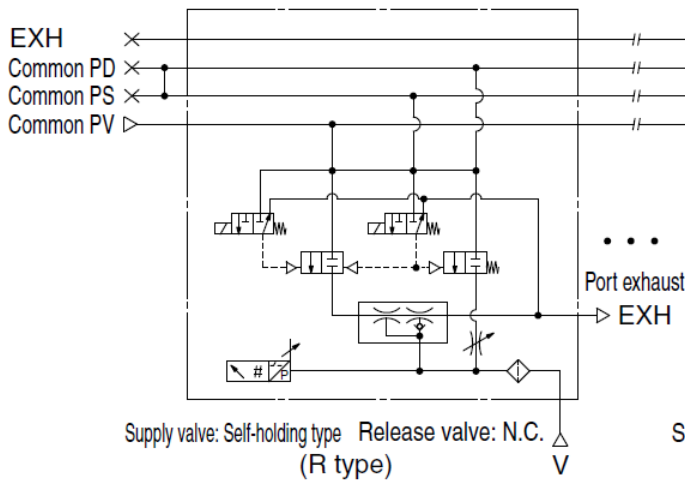

8

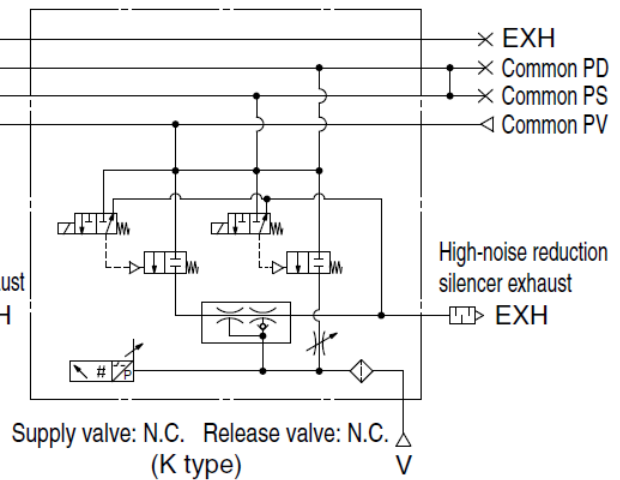

■ Option -D (With individual release pressure supply(PD) port)

Port Layout No. 9

Port combination: PV ≠ PS ≠ PD

Single unit: **ZK2P00**□□□□**A-□-D**

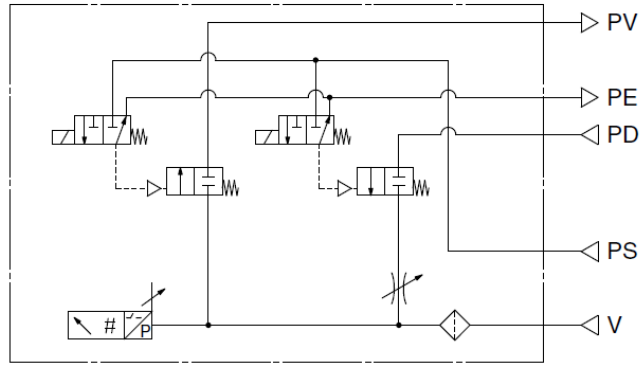
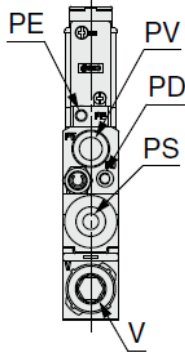

Supply valve: N.C. Release valve: N.C.
(K type)

System		Vacuum pump
Body type		Single unit
Exhaust type		Without silencer
Application and purpose	Vacuum pressure	-
	Exhaust	-
	Release pressure	PD pressure has to be supplied with PS pressure.

Port Layout No. 10

Port combination: Common PV ≠ Common PS ≠ Common PD

Single unit: **ZK2Q00**□□□□**A-□**

Manifold: **ZK2**□□**A-P2**□-**D**

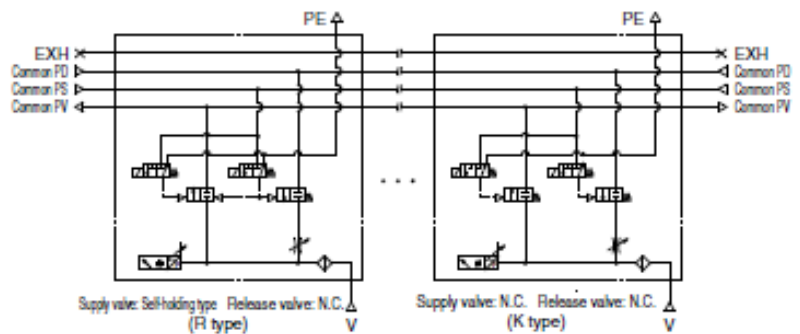
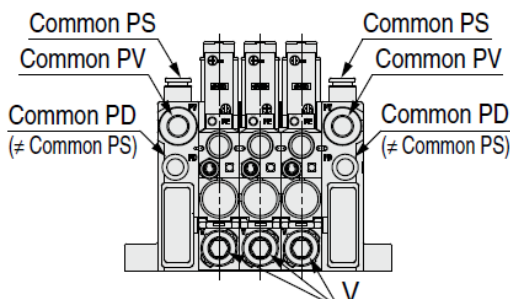

Supply valve: Self-holding type Release valve: N.C.
(R type)

Supply valve: N.C. Release valve: N.C.
(K type)

System		Vacuum pump
Body type		Manifold
Exhaust type		Without silencer
Application and purpose	Vacuum pressure	Common for each station
	Exhaust	-
	Release pressure	Common PD pressure has to be supplied with common PS pressure.

Port Layout No. **11**

Port combination: **PV = PS ≠ PD**

Single unit: **ZK2A**□□□□□□**A-□-D**

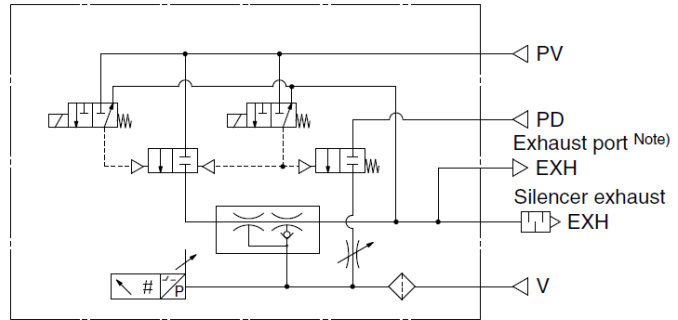
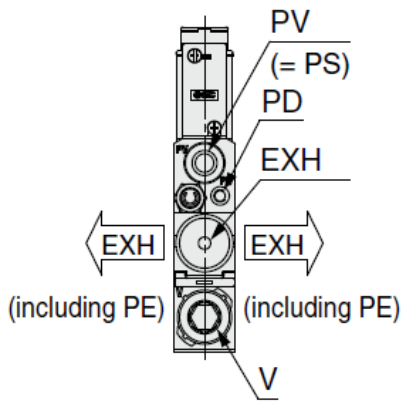

Supply valve: Self-holding type Release valve: N.C. (R type)

Note) Nozzle size: 12, 15

System		Ejector
Body type		Single unit
Exhaust type		Silencer exhaust
Application and purpose	Vacuum pressure	-
	Exhaust	Released in operating environment
	Release pressure	PD pressure has to be supplied with PV pressure.

Port Layout No. **12**

Port combination: **PV = PS ≠ PD**

Single unit: **ZK2B**□□□□□□**A-□-D**

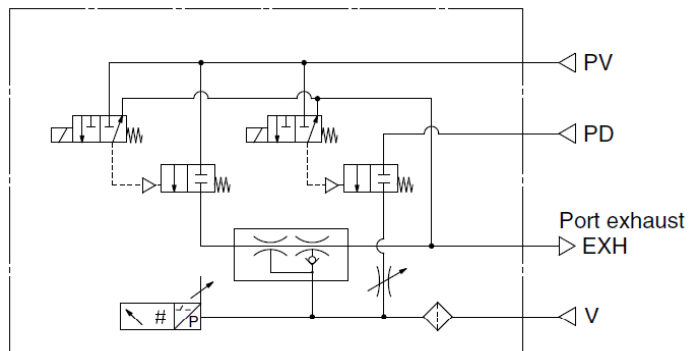
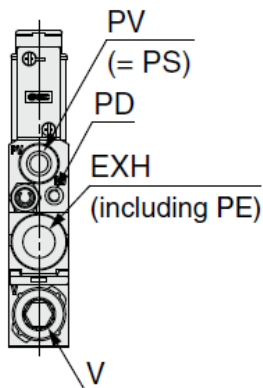

Supply valve: N.C. Release valve: N.C. (K type)

System		Ejector
Body type		Single unit
Exhaust type		Port exhaust
Application and purpose	Vacuum pressure	-
	Exhaust	After piping, individual exhaust is necessary.
	Release pressure	PD pressure has to be supplied with PV pressure.

Port
Layout No.

13

Port combination: PV = PS ≠ PD

Single unit: ZK2G□□□□□A-□-D

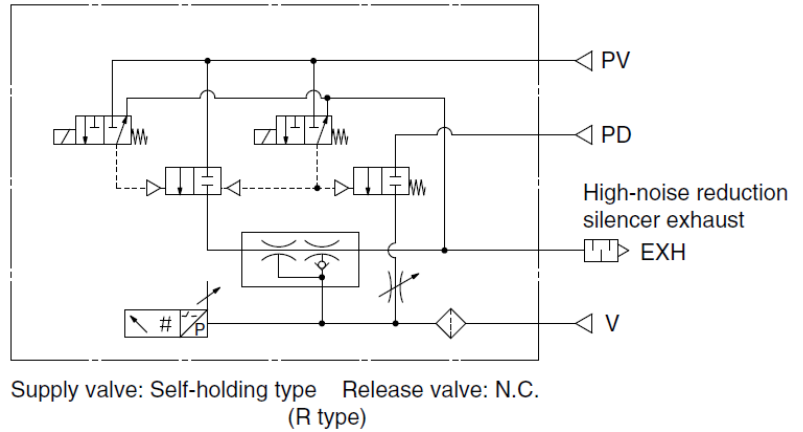
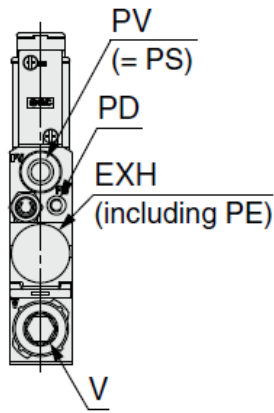

System		Ejector
Body type		Single unit
Exhaust type		High-noise reduction silencer exhaust
Application and purpose	Vacuum pressure	-
	Exhaust	Released in operating environment
	Release pressure	PD pressure has to be supplied with PV pressure.

Port
Layout No.

14

Port combination: Common PV = Common PS ≠ Common PD

Single unit: ZK2C□□□□□□A-□-P

Manifold: ZZK2□□A-A1□-D

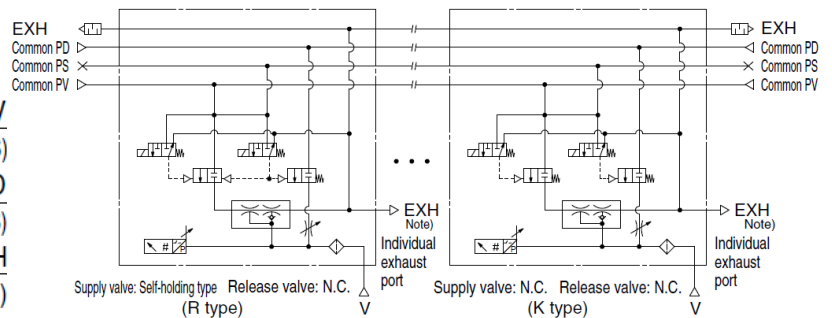
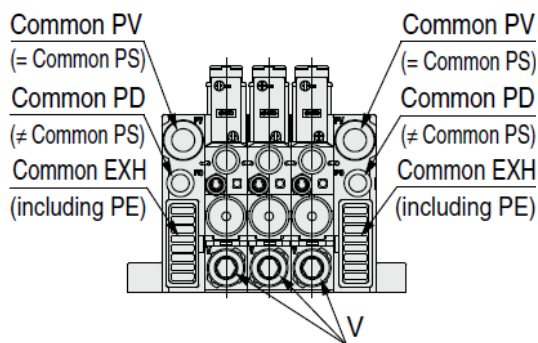

Note) For complex exhaust type, individual exhaust port is provided to each station.

System		Ejector
Body type		Manifold
Exhaust type		Complex exhaust
Application and purpose	Vacuum pressure	Common for each station
	Exhaust	Released in operating environment
	Release pressure	Common PD pressure has to be supplied with common PV pressure.

Port
Layout No.

15

Port combination: Common PV = Common PS ≠ Common PD

Single unit: ZK2F□□□□□A-□-P

Manifold: ZZK2□□A-A2□-D

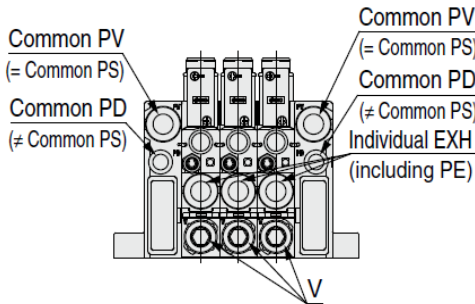

System		Ejector
Body type		Manifold
Exhaust type		Individual port exhaust
Application and purpose	Vacuum pressure	Common for each station
	Exhaust	After piping, individual exhaust is necessary.
	Release pressure	Common PD pressure has to be supplied with common PV pressure.

Port
Layout No.

16

Port combination: Common PV = Common PS ≠ Common PD

Single unit: ZK2H□□□□□A-□-P

Manifold: ZZK2□□A-A2□-D

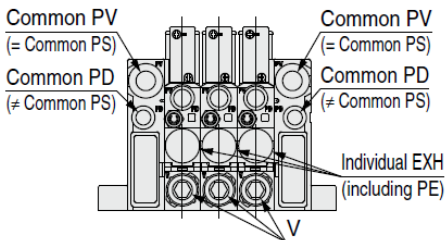

System		Ejector
Body type		Manifold
Exhaust type		High-noise reduction silencer exhaust
Application and purpose	Vacuum pressure	Common for each station
	Exhaust	Released in operating environment
	Release pressure	PD pressure has to be supplied with PV pressure.

15

16

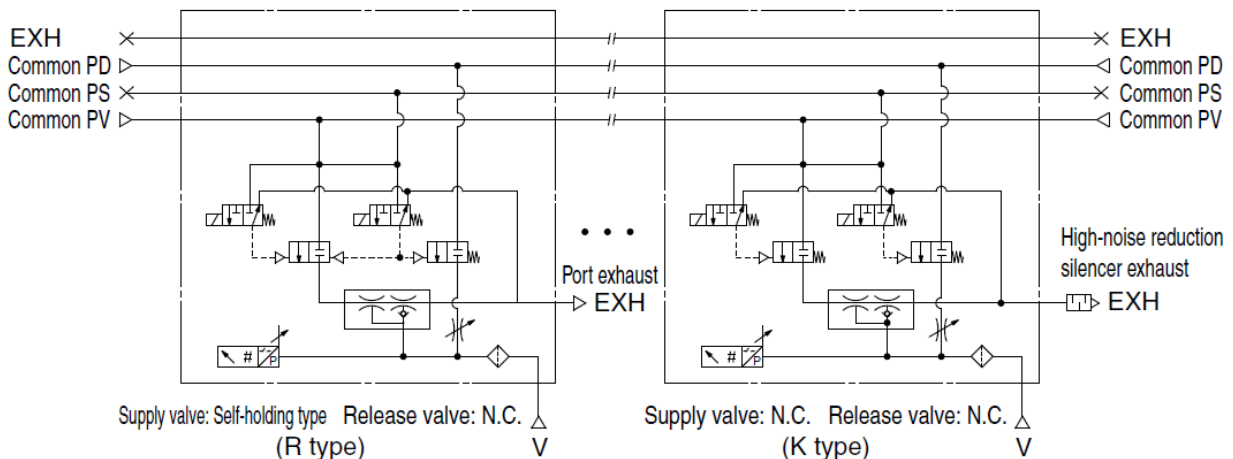

■ Option -L (Manifold individual supply specification)

Port Layout No. 17

Port combination: Individual PV ≠ Common PS = Common PD

Single unit: **ZK2C**□□□□□□**A**-□-**L**

Manifold: **ZZK2**□□**A-A1**□-**L**

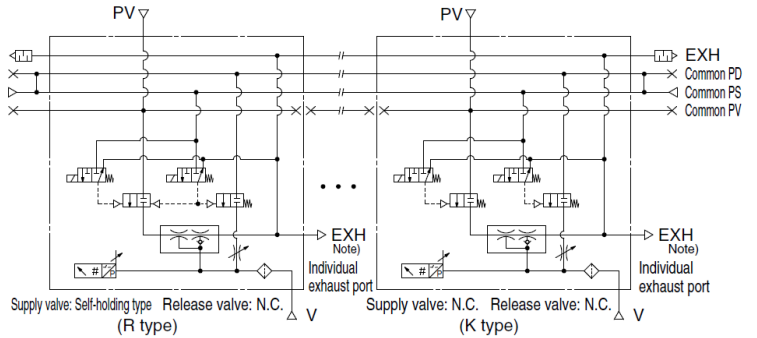
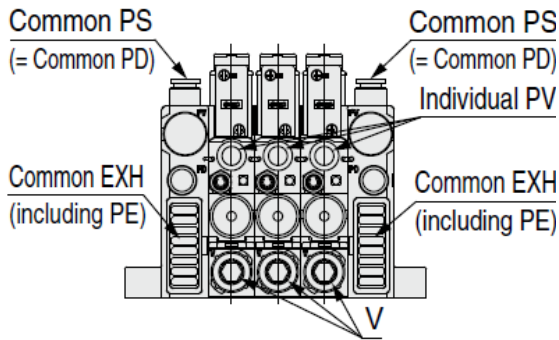

System		Ejector
Body type		Manifold
Exhaust type		Complex exhaust
Application and purpose	Vacuum pressure	PV pressure can be changed per station.
	Exhaust	Released in operating environment
	Release pressure	Same pressure for common PS pressure and common PD pressure.

Port Layout No. 18

Port combination: Individual PV ≠ Common PS = Common PD

Single unit: **ZK2F**□□□□□□**A**-□-**L**

Manifold: **ZZK2**□□**A-A2**□-**L**

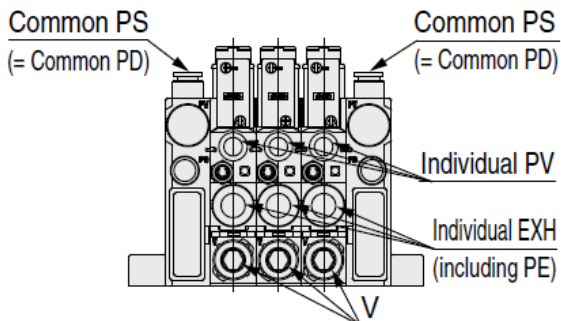

System		Ejector
Body type		Manifold
Exhaust type		Individual port exhaust
Application and purpose	Vacuum pressure	PV pressure can be changed per station.
	Exhaust	After piping, individual exhaust is necessary.
	Release pressure	Same pressure for common PS pressure and common PD pressure.

Port
Layout No.

19

Single unit: ZK2H□□□□A-□-L

Manifold: ZK2□□A-A2□-L

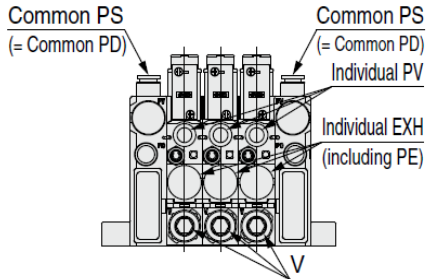

System		Ejector
Body type		Manifold
Exhaust type		High-noise reduction silencer exhaust
Application and purpose	Vacuum pressure	PV pressure can be changed per station.
	Exhaust	Released in operating environment
	Release pressure	Same pressure for common PS pressure and common PD pressure.

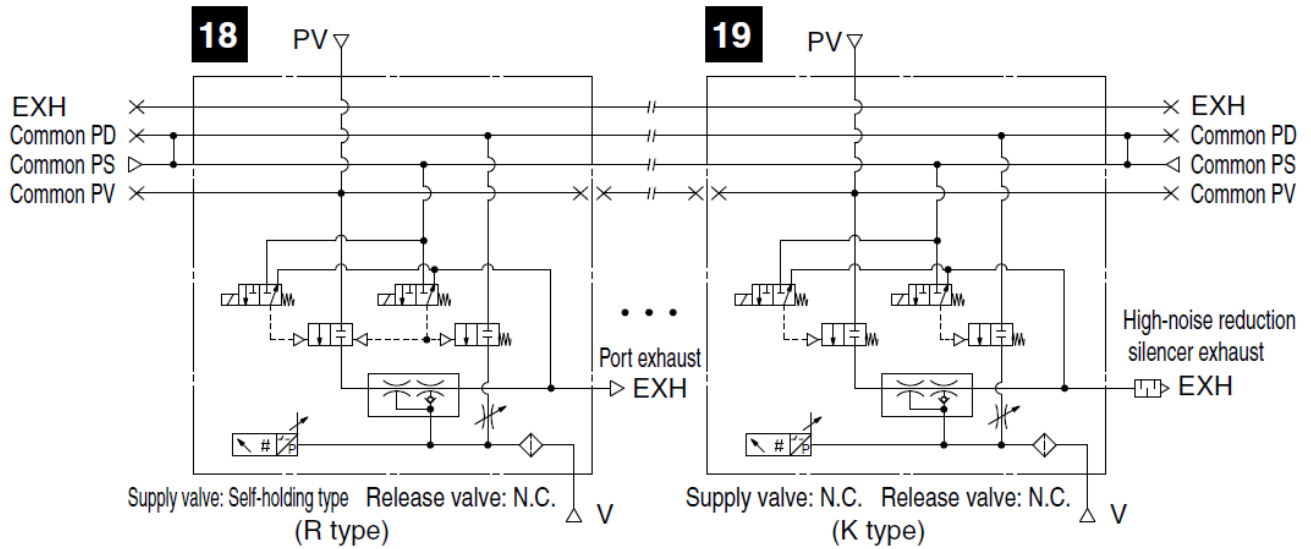

11. Exhaust/Flow Rate Characteristics

11.1. Ejector Exhaust Characteristics/Flow Rate Characteristics

The flow rate characteristics correspond to the standard supply pressure.

ZK2□07

Exhaust Characteristics

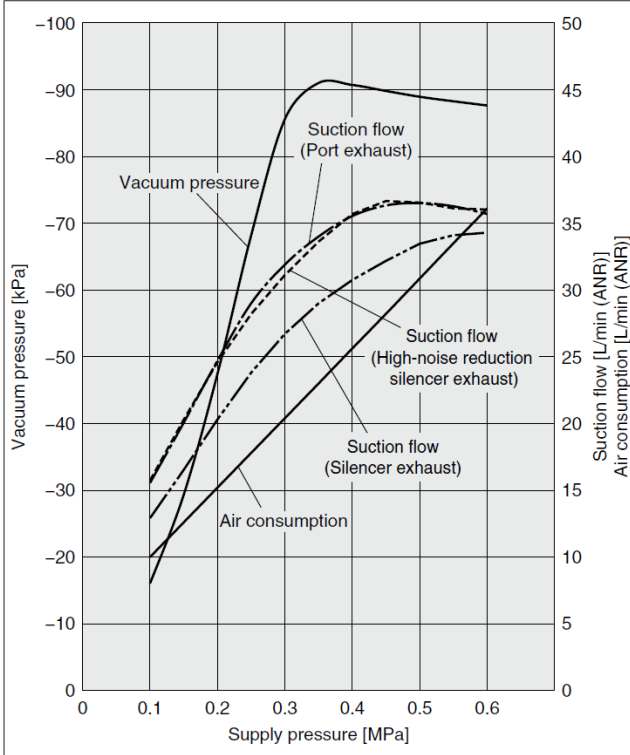

Flow Rate Characteristics

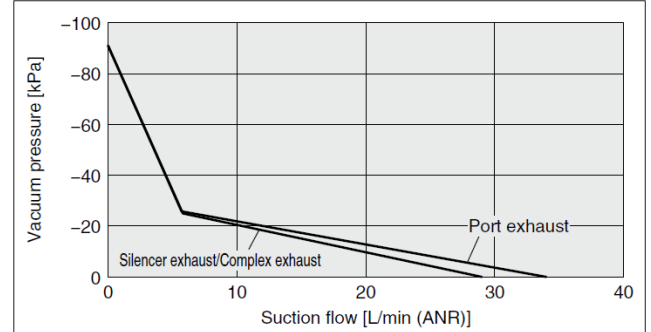

Flow Rate Characteristics

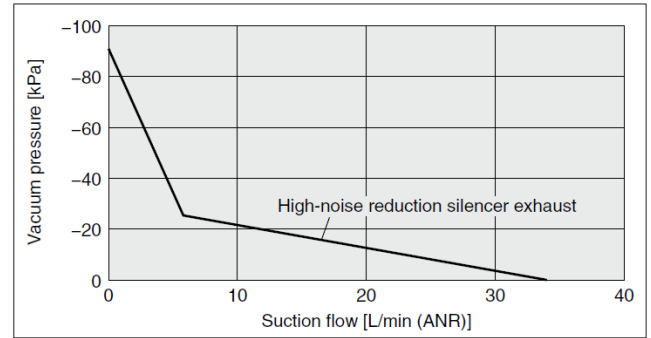

ZK2□10

Exhaust Characteristics

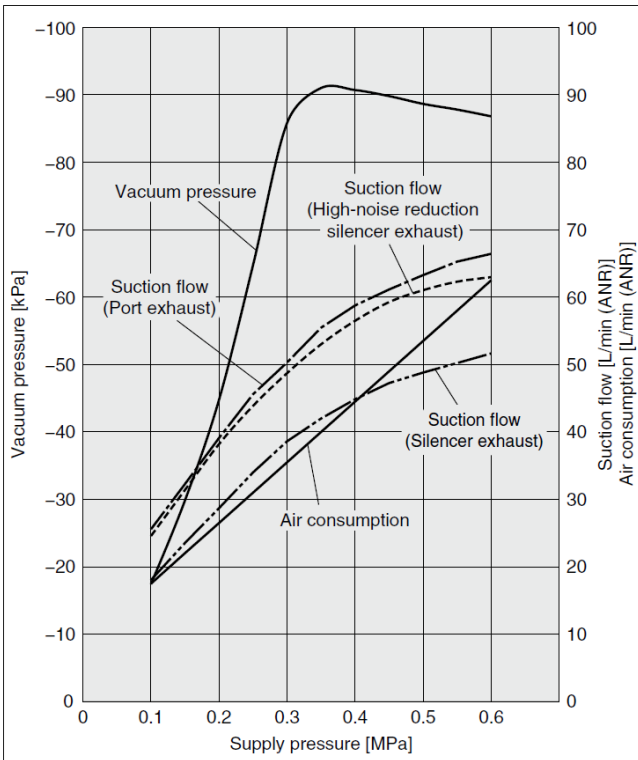

Flow Rate Characteristics

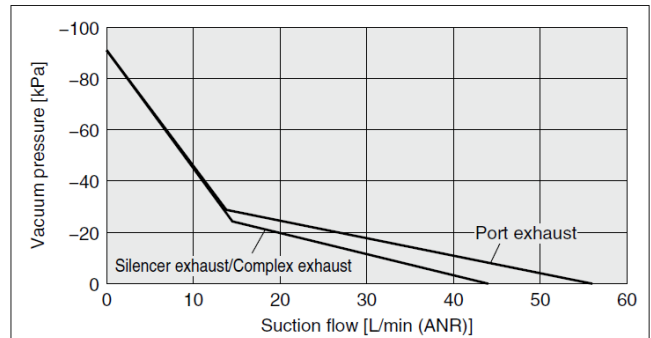

Flow Rate Characteristics

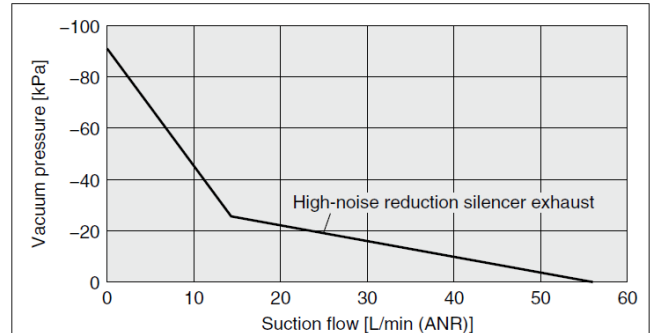

ZK2□12

Exhaust Characteristics

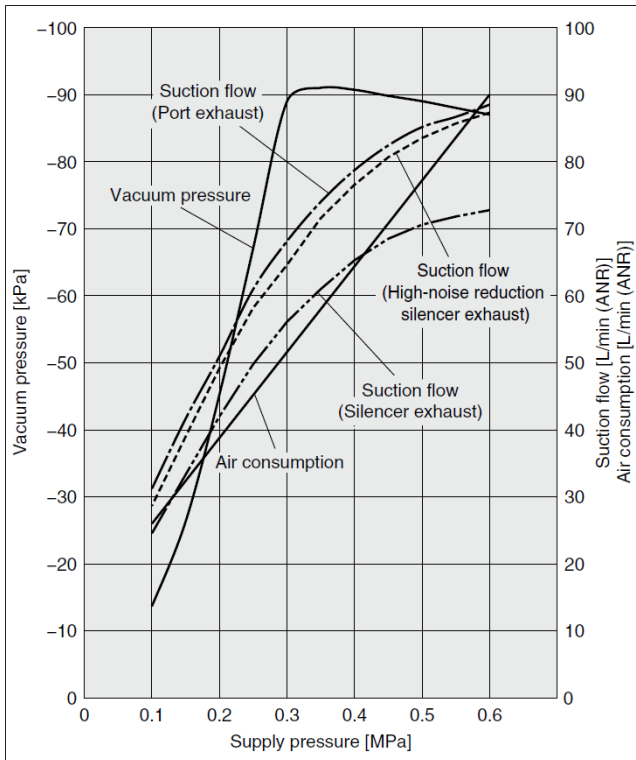

Flow Rate Characteristics

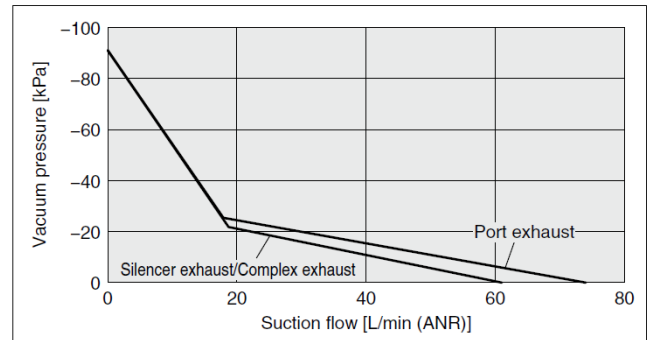

Flow Rate Characteristics

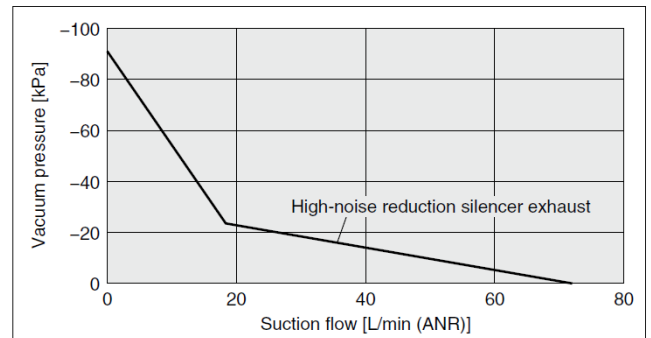

ZK2□15

The following graphs show the characteristics of the ejector with valve. (Please contact SMC for models without valve.)

Exhaust Characteristics

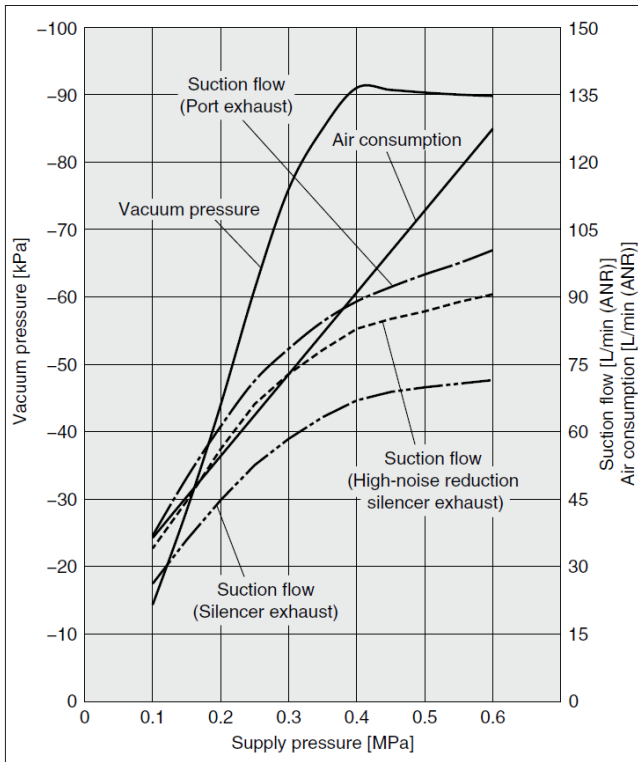

Flow Rate Characteristics

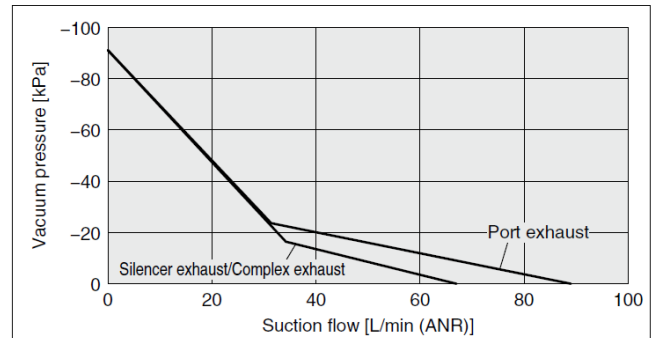

Flow Rate Characteristics

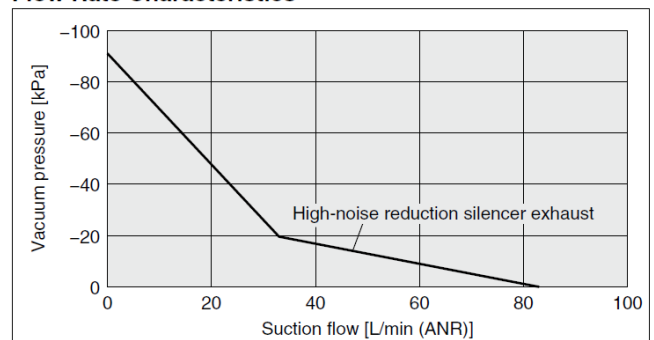

11.2. Vacuum Pump System Flow Rate Characteristics

The graph shows the suction flow rate characteristics of the vacuum pump system at different vacuum pressure.

ZK2P00

Flow rate characteristics of different vacuum pressure

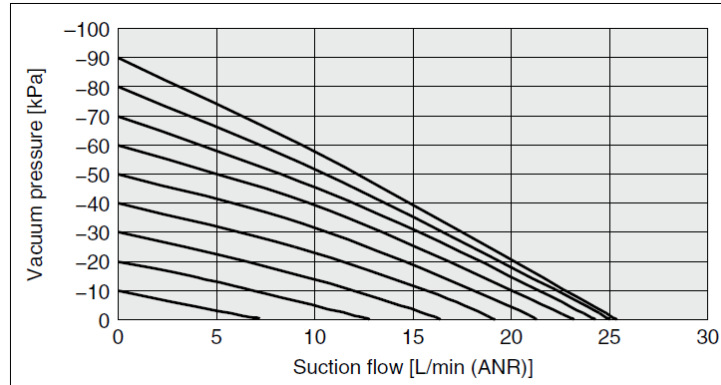

The actual suction flow at the point of suction varies depending on the piping conditions to the vacuum port. (The above graph shows the value when V port is $\varnothing 8$.)

Port size		Flow rate characteristics of V to PV (Vacuum side)		
PV port	V port	C[dm ³ /(s·bar)]	b	Cv
$\varnothing 6$	$\varnothing 8$	0.39	0.14	0.09

11.3. Vacuum Release Flow Rate Characteristics

The graph shows the flow rate characteristics at different supply pressures when the vacuum break flow adjusting needle is open from the fully closed state.

ZK2□□□ (Ejector)

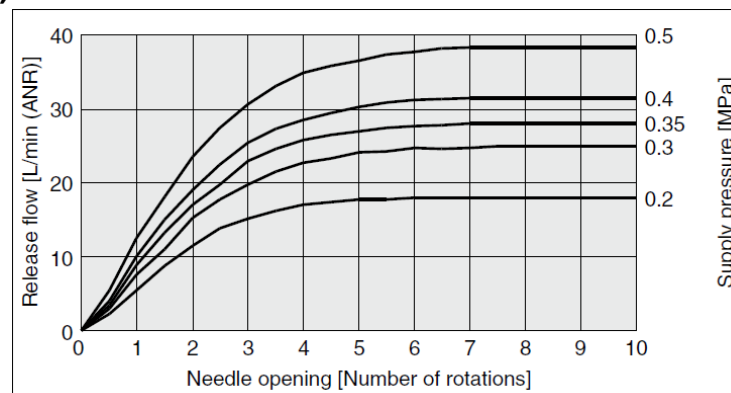

The actual suction flow at the point of suction varies depending on the piping conditions to the vacuum port. (The above graph shows the value of the ZK2B07)

■ ZK2□□□ (Vacuum Pump)

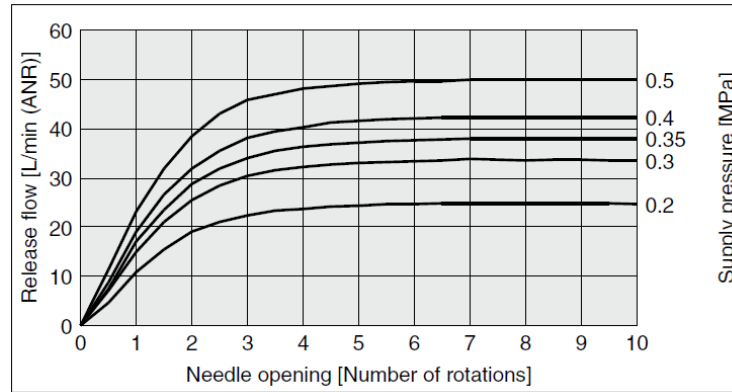

The actual suction flow at the point of suction varies depending on the piping conditions to the vacuum port.

Port size		Flow rate characteristics of PS to V (Vacuum release side) ^{Note)}		
PV port	V port	C[dm ³ /(s·bar)]	b	Cv
ø6	ø8	0.20	0.06	0.04

Note) When needle is fully open

■ Precautions

- The flow rate characteristics show the representative values of the product itself.
They may change depending on piping, circuit and pressure conditions, etc. The flow rate characteristics and the number of needle rotations vary due to the range of the specifications of the product.
- The needle has a retaining mechanism, so it will not turn further when it reaches the rotation stop position.
Turning the needle too far may cause damage.
- Do not tighten the handle with tools such as nippers.
This can result in breakage due to idle turning.
- Do not over tighten the lock nut.
It is possible to tighten the standard lock nut (hexagon) manually. When tightening further with tools, tighten by approximately 15° to 30°. Over tightening may cause breakage.
- When Vacuum break flow adjusting needle screwdriver operation type needle is selected as option (K), make sure the lock nut is not loose to prevent the nut from coming off due to vibration.

12. Limitations of Use

Exhaust from Ejector

The exhaust resistance should be as small as possible to obtain the full ejector performance. There should be no shield around the exhaust slit for silencer exhaust type. When the product is installed, one of the ports should be open to atmosphere.

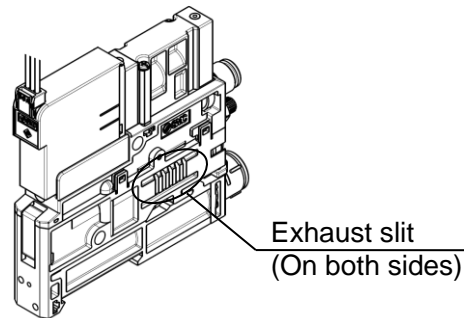

For port exhaust type, back pressure may increase depending on the piping size and length. Ensure that the back pressure does not exceed 0.005 MPa (5 kPa). For the nozzle products with a nozzle diameter for a large amount of exhaust air (air consumption + suction flow), such as $\varnothing 1.5$ (ZK[] 15), precaution should be taken on vacuum pressure decrease. Figure A below shows the relation between the exhaust piping (piping diameter and length) and vacuum pressure. When connecting pipes on port exhaust types with an outer diameter of $\varnothing 8$ or more, connect them so that the joints do not interfere with each other (Fig. B).

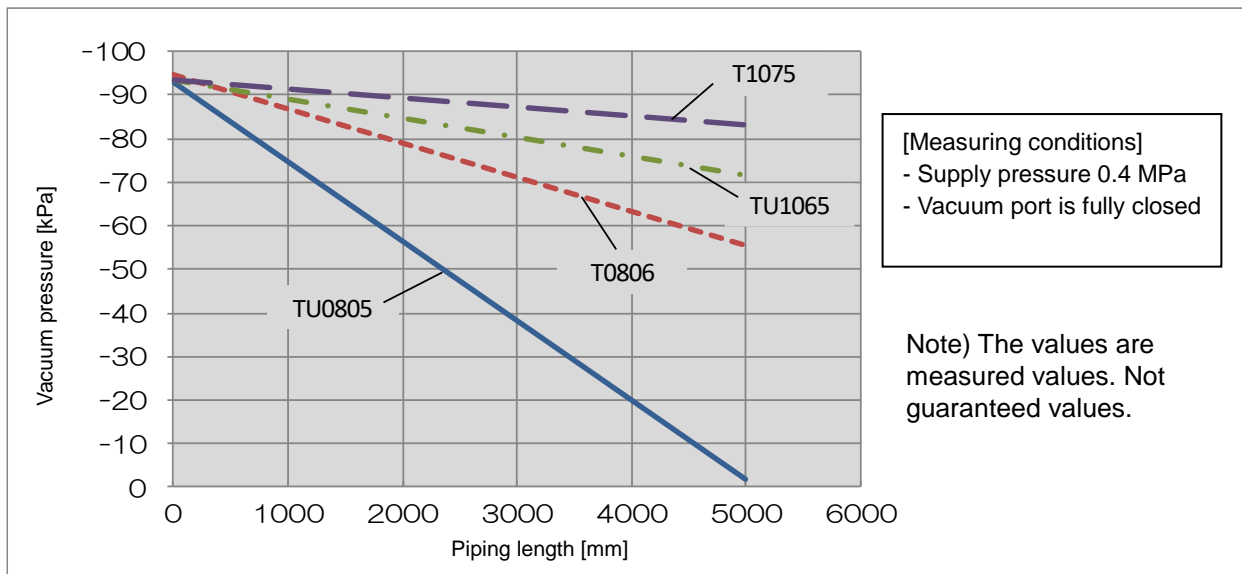

Fig. A. Vacuum pressure for piping (ZK \square 15)

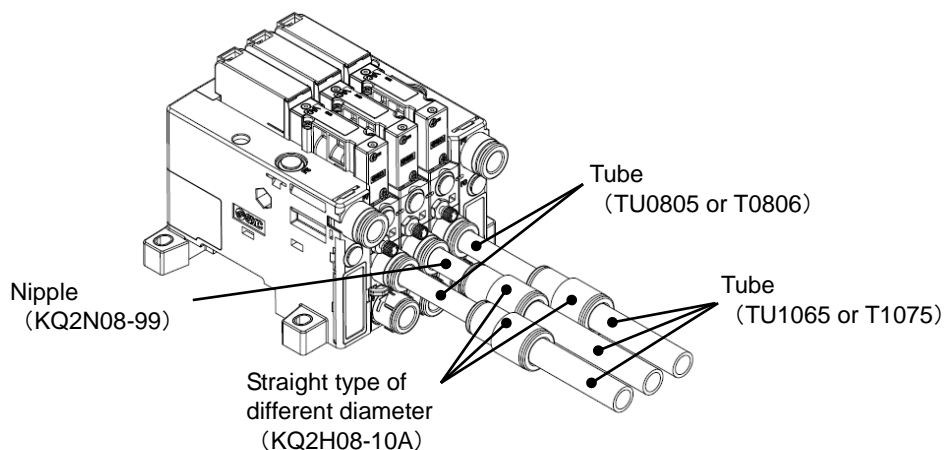

Fig. B Example of piping

In addition, the exhaust port should not be blocked or pressurized.

If the sound absorbing material is clogged, it will cause a reduction in the ejector performance.

Sometimes, if the operating environment contains a lot of particles or mist, the replacement of the filter element only is not enough to recover vacuum performance – as the sound absorbing material may be clogged. Replace the sound absorbing material. (Regular replacement of the filter element and sound absorbing material is recommended.)

■ Exhaust Noise

When vacuum ejector generates vacuum, noise can be heard from the exhaust port when the standard supply pressure is close to the pressure that generates peak vacuum pressure making vacuum pressure unstable. If the vacuum pressure range is adequate for adsorption, there should not be a problem. If the noise causes a problem or affects the setting of the pressure switch, change the supply pressure slightly to avoid the pressure range of the noise.

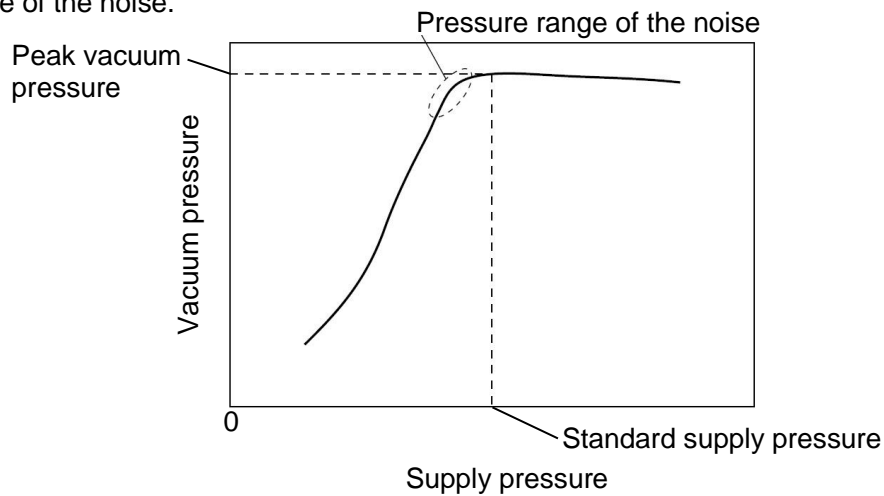

■ Maximum Number of Manifold Stations that Can Operate Simultaneously ^{Note)}

Item		ZK2□07	ZK2□10	ZK2□12	ZK2□15	
Air pressure supply (PV) port ø8, ø5/16"	Complex exhaust	Supply from one side	8	5	4	3
		Supply from both sides	10	7	5	5
	Individual port exhaust, High-noise reduction silencer exhaust	Supply from one side	8	6	6	3
		Supply from both sides	10	9	9	6

Note) As long as the number of stations operated simultaneously is the value on the table or less, then the manifold is available up to 10 stations.

13. Troubleshooting

■ Troubleshooting chart

When any malfunction is observed, it is recommended to perform the following troubleshooting.

Failure phenomenon		Possible causes		Countermeasures
Vacuum absorption failure	Vacuum is not generated	Clogging by foreign matter or particles		Refer to (1) and (2)
	Vacuum pressure decreased	Supply valve does not operate	Decline in the power supply voltage	Refer to (3) and (4)
			Electrical wire failure	Refer to (4) and (5)
			The supply pressure exceeds the operating pressure range	Refer to (6)
			Entry of oil mist	Refer to (16)
		Control failure	Simultaneous energization	Refer to (7)
			Leakage voltage	Refer to (8)
		Incorrect assembly during maintenance	Mounting failure of the gasket or check valve	Refer to (9)
		Insufficient supply pressure		Refer to (6) and (10)
	Deformation of the check valve		Refer to (9) and (11)	
Filter case gasket was protruded		Refer to (12)		
Fluctuation of vacuum pressure	Noise is generated intermittently when air is exhausted when absorbing by vacuum and vacuum pressure slightly fluctuates	Vibration of fluid when vacuum pressure is generated		Refer to (13)
Air leakage from vacuum port	Air leakage from the vacuum port when the release valve is OFF	Exhaust air flows to the vacuum port		Refer to (14)
Vacuum release failure	Release air is not output	Vacuum break flow adjusting needle is fully closed		Refer to (15)
		Release valve does not operate		Refer to (3), (4), (5), (6) and (16)
	Workpiece is not released smoothly	Decrease of release flow	Clogging of the suction filter	Refer to (17)
		Adhesion of the workpiece and pad		Refer to (18)
		Control failure	Simultaneous energization	Refer to (7)
			Leakage voltage	Refer to (8)
Operation failure of the pressure switch with energy saving function	Vacuum is not held. Supply valve chatters	Vacuum leakage		Refer to (19)
		Deformation of the check valve		Refer to (20)

■ Countermeasure

No.	Countermeasure
(1)	Oil mist in the supply air or particles in the piping cause clogging if they enter into the ejector. This may cause operation failure. Blow the air piping with air to eliminate particles. It is recommended installing the mist separator and air filter for cleaner supply air. Perform regular maintenance for mist separator and filter. Refer to the product catalogue or operation manual for details of the maintenance.
(2)	Substances adhere to the surface of the workpiece may enter into the ejector, causing clogging. Install an air suction filter with high filtration accuracy in the piping of the pad and ejector against foreign matter in the suction air (fine substances penetrating the built in filter element). Perform regular maintenance for the filter. Refer to the product catalogue or operation manual for details of the maintenance.
(3)	Adjust the rated voltage so that the supply voltage for the solenoid valve is within +/-10% of the rated voltage while the simultaneously energized equipment is ON. When the digital pressure switch is wired to the common power supply, the rated voltage shall be maintained while the switch is energized.
(4)	Check the correct connection of the power supply and wiring of plug connectors.
(5)	The connector assembly lead wire included in the product will be broken by repeated bending. When the ejector is installed to the moving part, use the wiring intended for moving parts. Fix the wiring to the device so that it is not affected by vibrations.
(6)	If the supply pressure is lower than the operating pressure range, it may cause operation failure of the main valve. If the supply pressure is higher than the operating pressure range, it may cause operation failure because of early defect due to wear of seals. Adjust the supply pressure appropriate for the specification for each port. Ejectors, especially the manifold products, consume a large amount of air during operation. Ensure that the supply pressure is within the operating range.
(7)	Vacuum pressure decreases if the release valve is energized while the supply valve operating. Check the control program and wiring.
(8)	Leakage voltage may cause the malfunction of the valve. Keep the leakage voltage at 0.48V or less.
(9)	The gasket or check valve came out or displaced during filter element maintenance or valve assembly replacement has to be put back to the correct position before reassembling in order to avoid the leakage of vacuum or air during operation. If the gasket or check valve is lost or broken, replace it with a new one.
(10)	If the supply pressure during the operation of the ejector decreases, the generated vacuum pressure decreases. Apply adequate flow rate so that the supply pressure is adequate when other air equipment operating simultaneously.
(11)	If the check valve has a problem, vacuum pressure does not increase adequately. In case of individual exhaust, if the ejector is operated with the exhaust port is pressurized or blocked, the check valve is deformed and held in the filter case vacuum path, making sealing impossible.
(12)	The parts around the vacuum port of this product are designed to be used with vacuum pressure. With the vacuum pump system, there is no release air to the atmosphere from a silencer. When the vacuum is released, the compressed air increases the pressure of the vacuum port and the filter case gasket may come out. Select the vacuum pad which shape allows smooth exhaust of release air to the atmosphere and avoid clogging.

No.	Countermeasure
(13)	<p>When the ejector vacuums the workpiece, high speed air coming out of the nozzle collides into the diffuser I.D. and bounces back, generating vibration in the exhaust air. Because of this, the vacuum pressure fluctuates slightly and is not stabilized.</p> <p>There should be no functional problem with the ejector. The phenomenon causes noise or could be a problem for the setting of vacuum switch. The noise can be eliminated by changing the supply pressure.</p> <p>Adjust the pressure regulating valve for supply pressure while checking the exhaust noise and vacuum pressure until the noise disappears.</p> <p>Ejector may generate noise due to the increase of exhaust resistance. When the silencer becomes dirty, the replacement of the silencer element may improve the condition.</p>
(14)	<p>In case of centralized piping, the exhausted air flows back into the ejector exhaust path which is not operating, and then exhausted from the vacuum port. In case of the manifold common exhaust, change it to the optional exhaust interference prevention valve type. It is possible to order a single exhaust interference prevention valve. When the individual exhaust type is a common piping, change it to individual exhaust piping, or change it to exhaust interference prevention valve type. Please refer to the product catalogue for mounting the exhaust interference prevention valve.</p>
(15)	<p>Release air is not output if the vacuum break flow adjusting needle is fully closed. Adjust the needle in an appropriate position.</p>
(16)	<p>If oil mist enters into the product, the grease of the valve assembly and main valve is washed away with the mist, adversely affect the valve operation. In addition, the life of the main valve may be shortened. Install the mist separator and air filter to the supply air piping for the ejector.</p>
(17)	<p>If the suction filter is clogged, relief air passing through the filter decreases. Liquid or fine particles enter into the filter element fibers. Periodic maintenance or installation of an external air suction filter with a large capacity is recommended.</p>
(18)	<p>The vacuum pad surface contacting with the workpiece is deteriorated over the number of contact. The workpiece may not be contacted correctly if the surface is deteriorated due to the increase of the rubber viscosity. If the rubber viscosity increases, replace the pad.</p>
(19)	<p>The product with pressure switch with energy saving function reduces air consumption by stopping air supply by creating vacuum between the check valve and pad in the ejector while adsorbing the workpiece. When the holding vacuum decreases, the supply valve turns on at the previously set threshold to supply vacuum pressure so that the workpiece does not fall.</p> <p>Therefore, if the holding time is very short, highly frequent ON/OFF operation will cause phenomenon like chattering. In this case, improve the leakage or release the setting of energy saving. Contact your sales representative for release method.</p>
(20)	<p>If the check valve is deformed, vacuum pressure is not maintained. In case of individual exhaust, if the ejector is operated with the exhaust port is pressurized or blocked, the check valve is deformed and held in the filter case vacuum path, making sealing impossible. When the deformed check valve does not return to flat, replace the check valve with a new one.</p>

Revision history

SMC Corporation

4-14-1, Sotokanda, Chiyoda-ku, Tokyo 101-0021 JAPAN

Tel: + 81 3 5207 8249 Fax: +81 3 5298 5362

URL <http://www.smcworld.com>

Note: Specifications are subject to change without prior notice and any obligation on the part of the manufacturer.

© 2019 SMC Corporation All Rights Reserved