

# Vacuum Pad

Flat type with ribs  $\varnothing 32, \varnothing 40, \varnothing 50$   
 Bellows type

**Suitable for the adsorption transfer of corrugated cardboard, etc., requiring abrasion resistance**

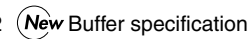
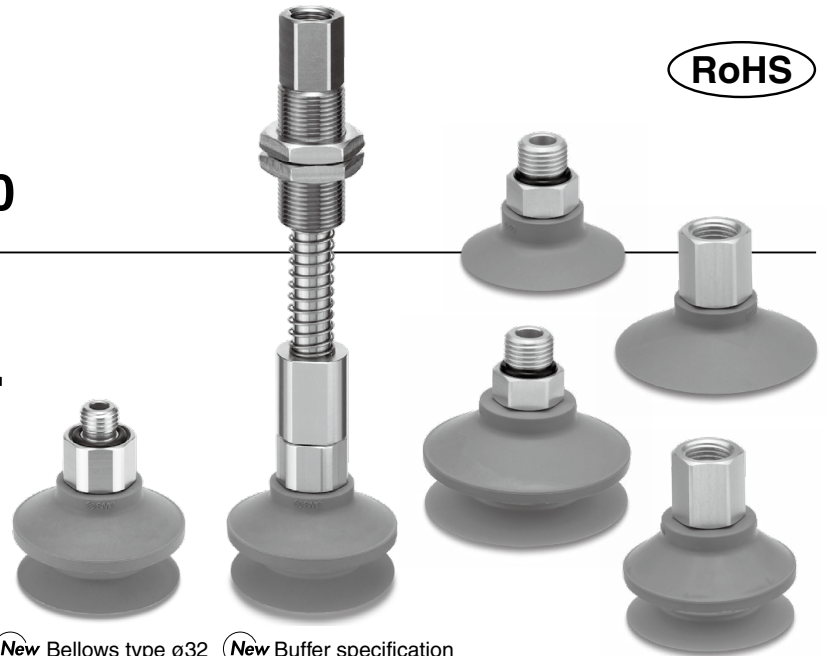

**Material: FS61 (Fluoro-based rubber) improves abrasion resistance**

\* More than twice the abrasion resistance of SMC's urethane pads

**Easier maintenance**

- Compatible with 2 types of mounting tools

① Mounting with a hexagon wrench

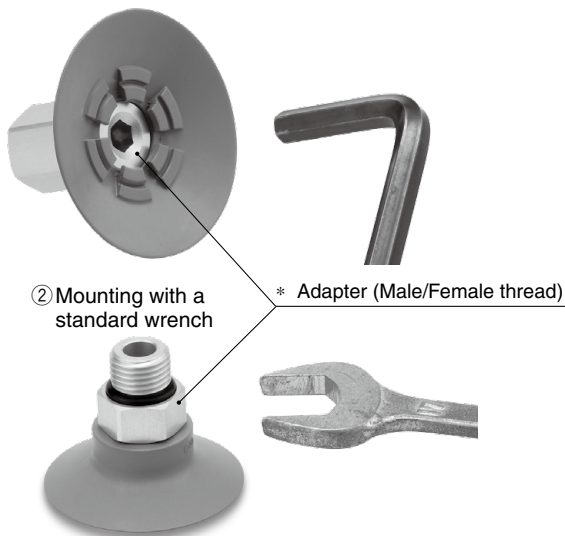

**Reduced suction of foreign matter due to mesh filter**

- Reduced suction of foreign matter into the vacuum pump and ejector
- The pad and mesh filter can be replaced without tools.
- The separation and disposal of the metal and rubber parts is possible.

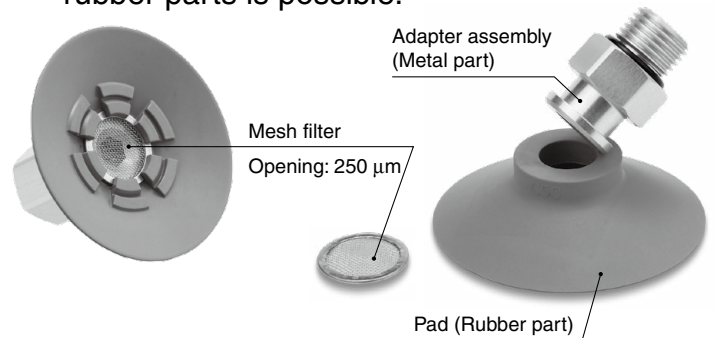

**Application example**

For the transfer of corrugated cardboard

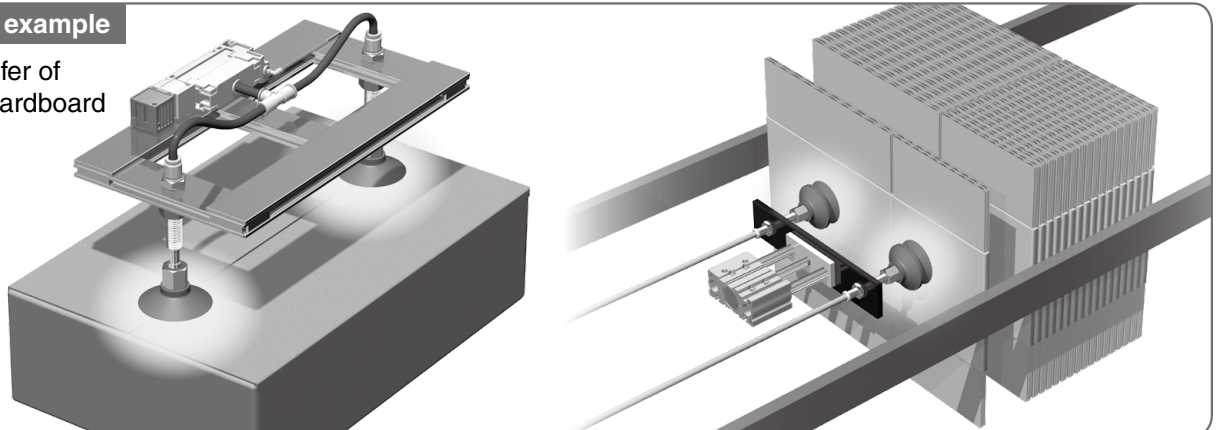

**ZP3C Series**





# Vacuum Pad

Flat Type with Ribs Bellows Type

# ZP3C Series

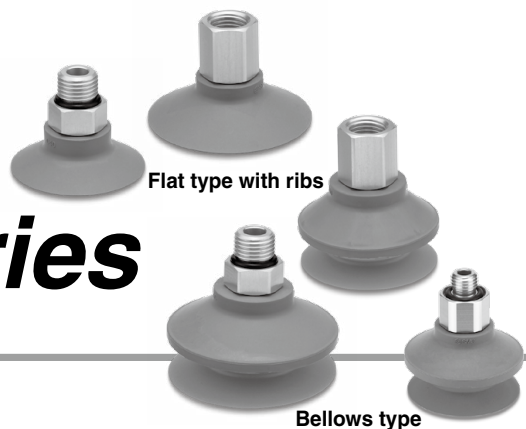

## How to Order

**Pad unit** ZP3C - **40** **C** **FS**

**With adapter** ZP3C - **T** **40** **C** **FS** - **MF** - **A10**

**With buffer** ZP3C - **T** **40** **C** **FS** **JB** **10** - **MF**

① ② ③ ④ ⑤ ⑥ ⑦

• Pad material: FS61

### ① Vacuum inlet direction

Nil	Pad unit
T	Vertical
Y*1	Lateral

\*1 Only selectable for the type with a buffer

### ② Pad diameter

32	ø32
40	ø40
50	ø50

### ③ Pad form

Symbol	Pad diameter	Pad diameter [mm]	
		ø32	ø40, ø50
C	Flat type with ribs	—	●
B	Bellows type	●	●

### ④ Buffer specifications

JB	Rotating, With bushing
----	------------------------

### ⑤ Buffer stroke

Stroke [mm]	Pad diameter [mm]	
	ø32	ø40, ø50
10	●	●
20	●	—
30	●	●
50	—	●

### ⑥ Mesh filter

Nil	Without mesh filter
MF	With mesh filter

### ⑦ Connection thread

Type	Thread	Symbol	Size	Pad diameter [mm]	
				ø32	ø40, ø50
Direct mounting	Male thread	A8	M8 x 1	●	—
		A10	M10 x 1	—	●
		AG01	G1/8	●	—
	Female thread	AG02	G1/4	—	●
		BG01	G1/8	●	—
		BG02	G1/4	—	●

\* Use the connection thread for the vacuum inlet.

## Pad/Mesh Filter Specifications

Pad	Material	FS61 (Fluoro-based rubber)
	Color	Green
	Hardness (Shore A: ±5°)	60
Mesh filter	Opening: 250 µm	

## Buffer Specifications

Pad diameter		ø20, ø25, ø32			ø40, ø50		
Non-rotating specification		Rotating, With bushing					
Stroke		10	20	30	10	30	50
Connection thread		M14 x 1			M18 x 1.5		
Spring reactive force [N]	At 0 stroke	3.0			5.0		
	At full stroke	4.5	5.0	5.2	6.5	8.5	10.5

## Dimensions

### Pad unit

Flat type with ribs

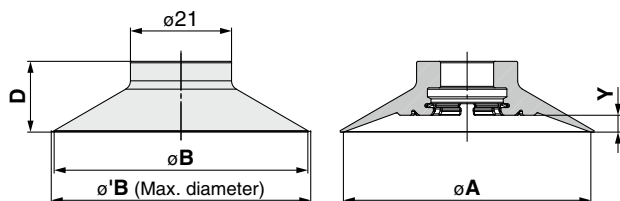

Bellows type

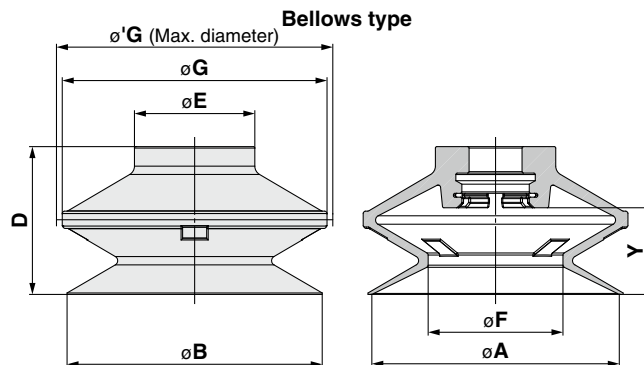

Model	Model			A	B	'B*1	D	E	F	G	'G*1	Y	Weight [g]
	② Pad dia.	③ Pad form	Pad material										
ZP3C	40	C	FS	41.4	43	44.2	13.7	—	—	—	—	2.5	7.9
	50			51.4	52.7	53.9	14.7	—	—	—	—	3.5	11.6
	32			31.4	33	—	21.8	17	18.5	35	37	12.8	8.4
	40	B		41.4	43	—	28.7	24	25	45	47.5	16	17.7
	50			51.4	53	—	30.7	25	28	55	57.5	18	26.6

\*1 Achieved vacuum pressure: Reference at -85 [kPa]

## Dimensions

**With adapter**  $\phi 40, \phi 50$  (Flat type with ribs)

Connection thread: Male thread

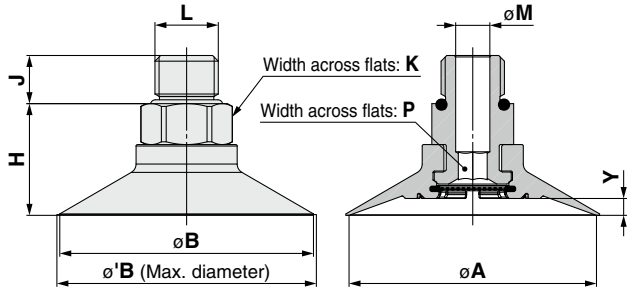

Connection thread: Female thread

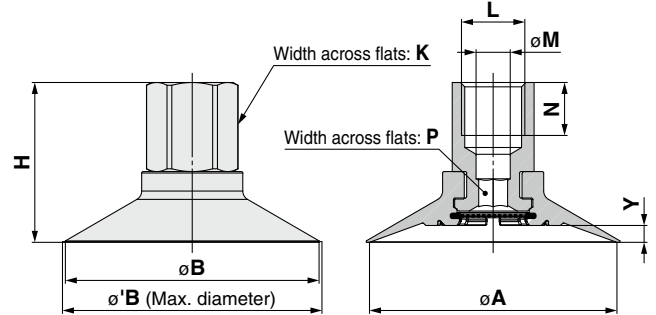

	Model					H	J	K	L	M	N	P	Weight [g]	
	② Pad dia.	③ Pad form	Pad material	⑥ Mesh filter	⑦ Connection thread									
ZP3C-T	40	C	FS	MF	A10	22.2	6.5	17	M10 x 1	6	—	6	16.7	
					AG02		10		G1/4	7.1	—		18.2	
					BG02		—		11	18.9				
	50				A10	23.2	6.5		17	M10 x 1	6		—	20.5
					AG02		10			—	21.9			
					BG02		—			11	22.6			

**With adapter**  $\phi 32$  to  $\phi 50$  (Bellows type)

Connection thread: Male thread

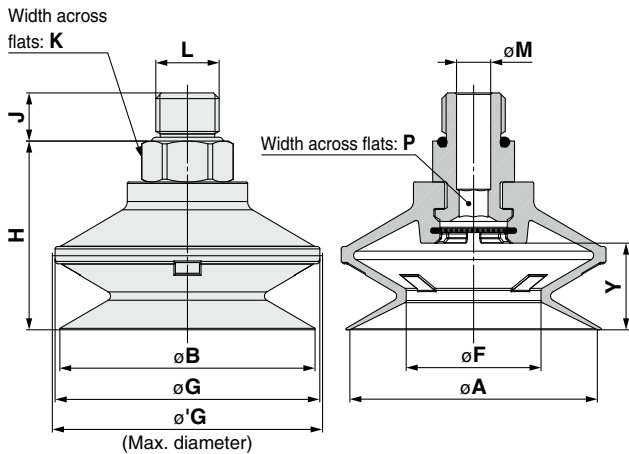

Connection thread: Female thread

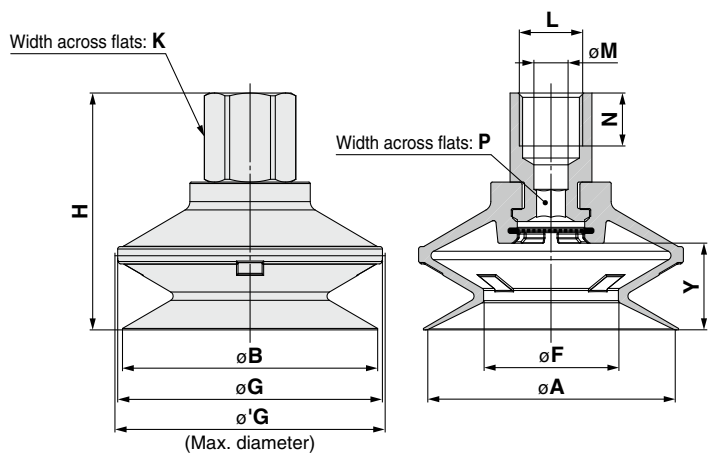

	Model					H	J	K	L	M	N	P	Weight [g]				
	② Pad dia.	③ Pad form	Pad material	⑥ Mesh filter	⑦ Connection thread												
ZP3C-T	32	B	FS	MF	A8	31.8	6.5	14	M8 x 1	4	—	4	14.2				
					AG01		7.5		G1/8		7.4		13.4				
					BG01		—		—		14.4						
	40				A10	37.2	6.5		17	M10 x 1	6		—	6	26.5		
					AG02		10			G1/4	7.1		—		28.0		
					BG02		—			11	28.7						
	50				A10	39.2	6.5			17	M10 x 1		6		—	6	35.4
					AG02		10				—		36.9				
					BG02		—				11		37.6				

# ZP3C Series

## Dimensions

**With buffer**  $\varnothing 40, \varnothing 50$  (Flat type with ribs)

Vacuum inlet direction **Vertical**

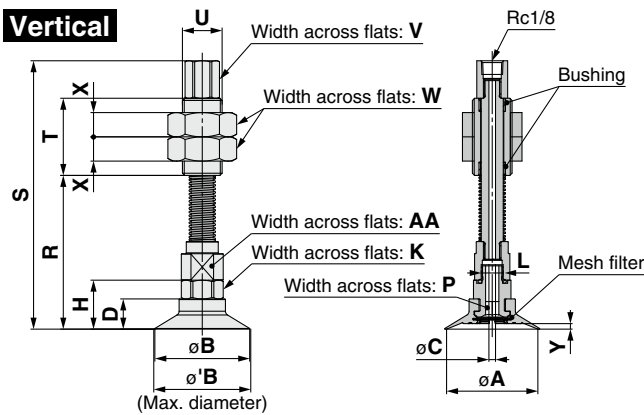

Model							C	H	K	L	P	R	S	T	U	V	W	X	AA
① Vacuum inlet direction	② Pad dia.	③ Pad form	④ Pad material	⑤ Buffer spec.	⑥ Buffer stroke	⑦ Mesh filter													
ZP3C	T	40	C	FS	JB	10	3	22.2	17	M10 x 1	6	69.7	121.7	35	M18 x 1.5	14	27	11	16
						30						94.7	146.7						
						50						114.7	166.7						
	50	Nil MF	10	70.7	122.7														
			30	95.7	147.7														
			50	115.7	167.7														

**With buffer**  $\varnothing 32$  to  $\varnothing 50$  (Bellows type)

Vacuum inlet direction **Vertical**

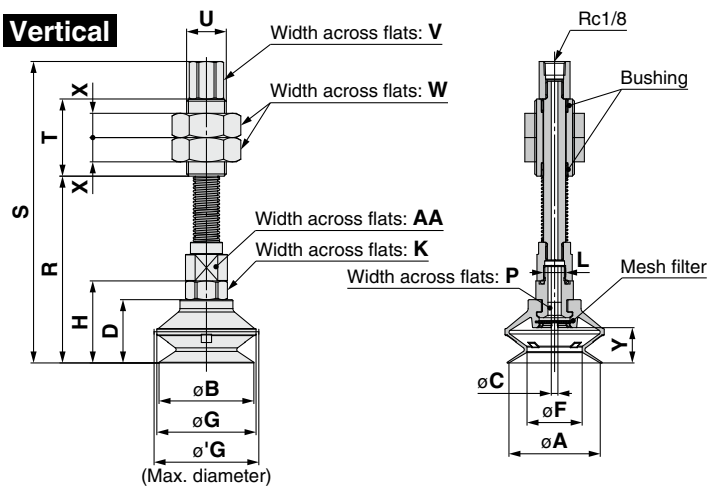

Model							C	H	K	L	P	R	S	T	U	V	W	X	AA
① Vacuum inlet direction	② Pad dia.	③ Pad form	④ Pad material	⑤ Buffer spec.	⑥ Buffer stroke	⑦ Mesh filter													
ZP3C	T	32	B	FS	JB	10	3	31.8	14	M8 x 1	4	77.8	122.8	30	M14 x 1	12	19	4	13
						20						89.8	134.8						
						30						102.8	147.8						
		10				84.7						136.7							
		30				109.7						161.7							
		50				129.7						181.7							
	50	Nil MF	10	39.2	17	M10 x 1	6	86.7	138.7	35	M18 x 1.5	14	27	11	16				
								30	111.7							163.7			
								50	131.7							183.7			

## Dimensions

**With buffer**  $\varnothing 40, \varnothing 50$  (Flat type with ribs)

Vacuum inlet direction **Lateral**

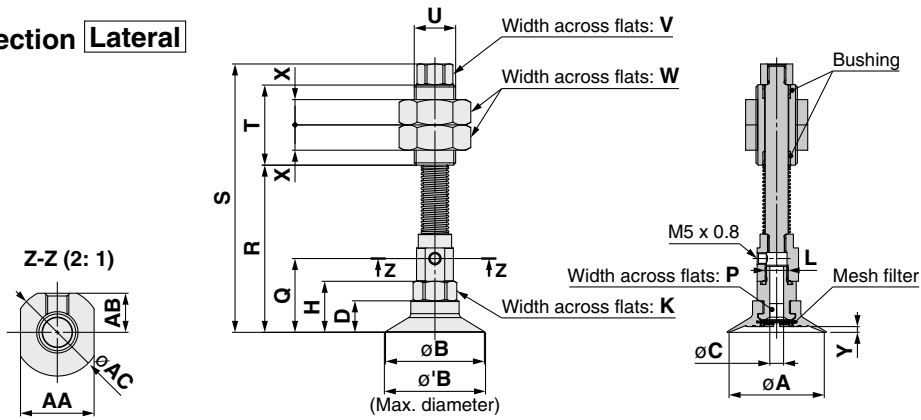

Model							C	H	K	L	P	Q	R	S	T	U	V	W	X	AA	AB	AC					
① Vacuum inlet direction	② Pad dia.	③ Pad form	④ Pad material	⑤ Buffer spec.	⑥ Buffer stroke	⑦ Mesh filter																					
ZP3C	Y	40	C	FS	JB	10	6	22.2	17	M10 x 1	6	32.1	72.7	116.7	35	M18 x 1.5	14	27	11	16	19	8.5					
						30							97.7	141.7													
						50							117.7	161.7													
		50				10							23.2	17									M10 x 1	6	33.1	73.7	117.7
						30																				98.7	142.7
						50																				118.7	162.7

**With buffer**  $\varnothing 32$  to  $\varnothing 50$  (Bellows type)

Vacuum inlet direction **Lateral**

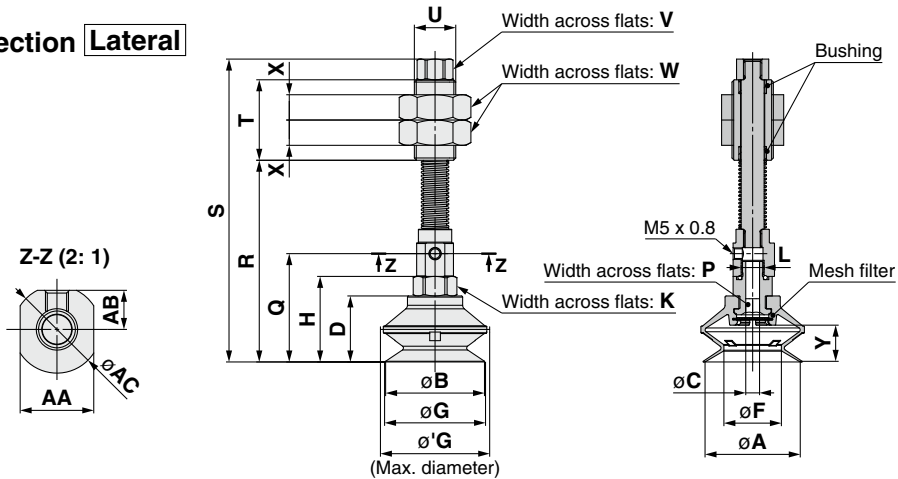

Model							C	H	K	L	Q	R	S	T	U	V	W	X	AA	AB	AC				
① Vacuum inlet direction	② Pad dia.	③ Pad form	④ Pad material	⑤ Buffer spec.	⑥ Buffer stroke	⑦ Mesh filter																			
ZP3C	Y	32	B	FS	JB	10	4	31.8	14	M8 x 1	40.8	77.8	115.8	30	M14 x 1	12	19	4	14	15	6.5				
						20						89.8	127.8												
						30						102.8	140.8												
		40				10						37.2	17									M10 x 1	47.1	87.7	131.7
						30																		112.7	156.7
						50																		132.7	176.7
		50	10	39.2	17	M10 x 1	49.1	89.7	133.7																
			30					114.7	158.7																
			50					134.7	178.7																

# Vacuum Pad **ZP3C Series**

## Construction

### With adapter

ZP3C-T□CFS-MF-(A10/AG02)

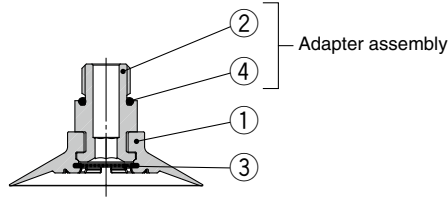

ZP3C-T□BFS-MF-(A8/A10/AG01/AG02)

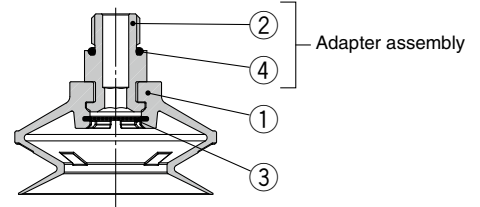

ZP3C-T□CFS-MF-BG02

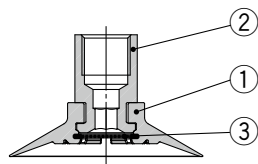

ZP3C-T□BFS-MF-(BG01/BG02)

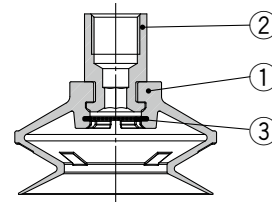

### Component Parts

No.	Description	Material	Note
1	Pad	FS61 (Fluoro-based rubber)	Color: Green
2	Adapter	Aluminum alloy (Clear anodized)	
3	Mesh filter	Stainless steel	With mesh filter
4	O-ring	NBR	

### With buffer

ZP3C-T□CFSJB□-□

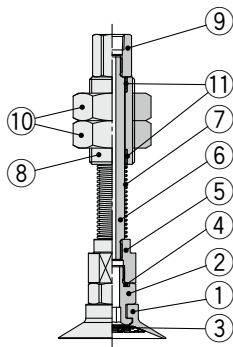

ZP3C-Y□CFSJB□-□

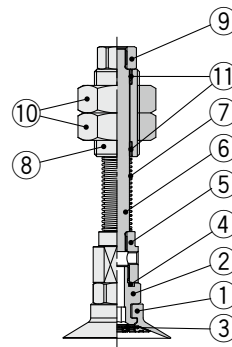

ZP3C-Y□BFSJB□-□

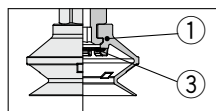

### Component Parts

No.	Description	Material	Note
1	Pad	FS61 (Fluoro-based rubber)	Color: Green
2	Adapter	Aluminum alloy (Clear anodized)	
3	Mesh filter	Stainless steel	With mesh filter
4	O-ring	NBR	
5	Adapter	Aluminum alloy (Clear anodized)	
6	Piston rod	Structural steel (Hard chrome plating)	
7	Return spring	Stainless steel	
8	Buffer body	Brass (Electroless nickel plating)	
9	Buffer adapter	Brass (Electroless nickel plating)	
10	Nut	Steel (Zinc chromated)	
11	Bushing	—	

### Replacement Parts

#### Mesh Unit

Part number	Applicable pad dia.
ZPMF-60-D11	ø32
ZPMF-60-D18	ø40, ø50

# Vacuum Pad *ZP3C Series* Mounting Bracket Assembly

## Adapter Assembly: Vacuum Inlet Direction **Vertical** T Type/ZP3C-T

Product part no.	<p style="text-align: center;"> <b>ZP3C - T</b> ① ② <b>FS</b> □ - ③          Pad diameter      Pad form      Pad material      Mesh filter      Connection thread (Male/Female thread)       </p>	
Component Parts	<p>ZP3C-T□(C/B)FS-□-A□</p> <p>① Adapter (With O-ring) Pad ② Mesh filter</p>	<p>ZP3C-T□(C/B)FS-□-BG□</p> <p>① Adapter Pad ② Mesh filter</p>

		Symbol	① Pad diameter symbol			
			32	40	50	
② Pad form	Flat type with ribs	<b>C</b>	—	●	●	
	Bellows type	<b>B</b>	●	●	●	
① Adapter (Single unit)	③ Connection thread	Male thread	M8 x 1	<b>A8</b>	ZP3CA-T3-A8	—
			M10 x 1	<b>A10</b>	—	ZP3CA-T4-A10
		Female thread	G1/8	<b>AG01</b>	ZP3CA-T3-AG01	—
			G1/4	<b>AG02</b>	—	ZP3CA-T4-AG02
	Female thread	G1/8	<b>BG01</b>	ZP3CA-T3-BG01	—	
		G1/4	<b>BG02</b>	—	ZP3CA-T4-BG02	
② Mesh filter (Single unit)			ZPMF-60-D11	ZPMF-60-D18		

Vacuum Pad  
Mounting Bracket Assembly **ZP3C Series**

■ Buffer Assembly: Vacuum Inlet Direction **Vertical** T Type/ZP3C-T, **Lateral** Y Type/ZP3C-Y

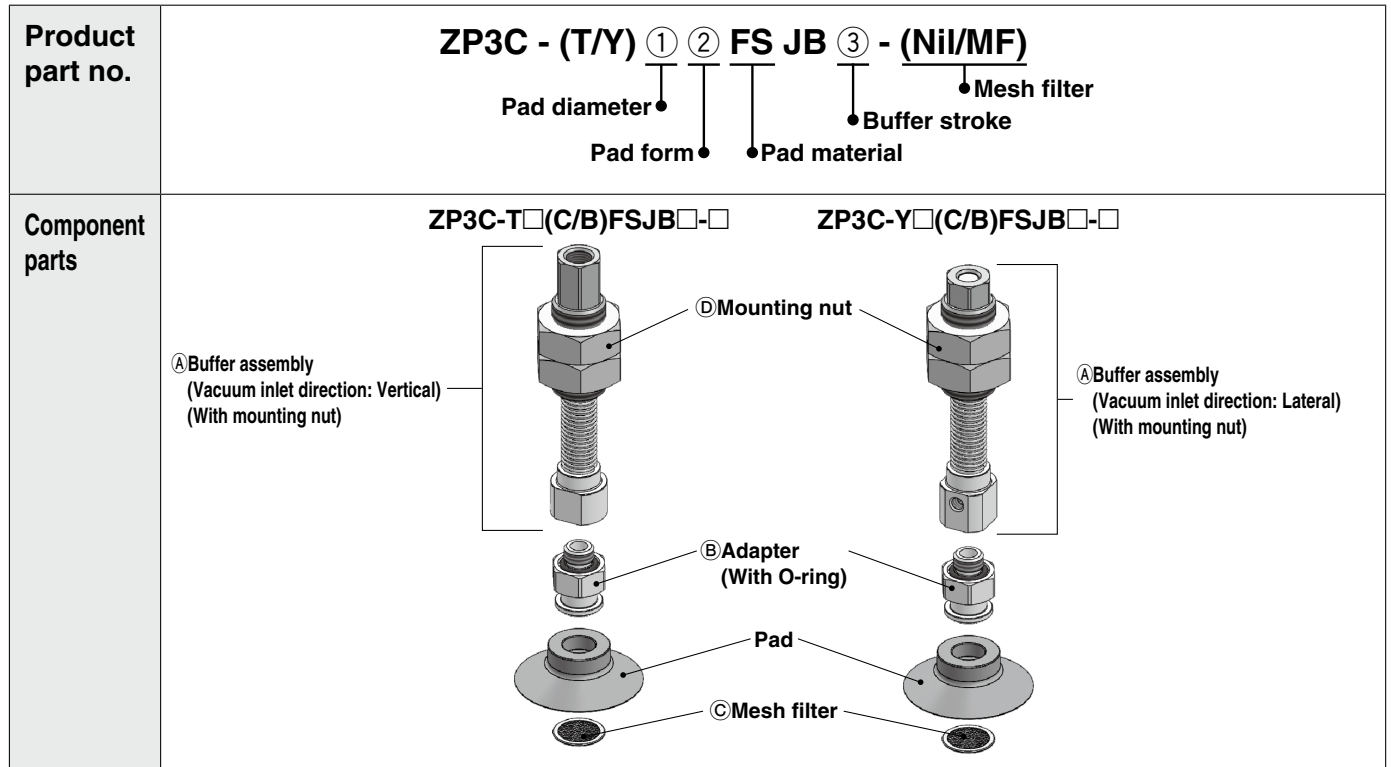

		Symbol	① Pad diameter symbol		
			32	40	50
② Pad form	Flat type with ribs	C	—	●	●
	Bellows type	B	●	●	●
③ Buffer stroke	Stroke	10	●	●	●
		20	●	—	—
		30	●	●	●
		50	—	●	●
A Buffer assembly (With mounting nut)			ZP3EB-(T/Y)JB③	ZP3EB-(T/Y)1JB③	
B Adapter (Single unit)			ZP3CA-T3-A8	ZP3CA-T4-A10	
C Mesh filter (Single unit)			ZPMF-60-D11	ZPMF-60-D18	
D Mounting nut (Single unit)		M14 x 1	ZPNA-M14	—	
		M18 x 1.5	—	NT-05	

[Buffer assembly part number example]

Product part no. ZP3C - T 40CFS JB 10

Buffer assembly ZP3EB - T 1 JB 10

③ Buffer stroke

**⚠ Safety Instructions** Be sure to read the "Handling Precautions for SMC Products" (M-E03-3) and "Operation Manual" before use.

# SMC Corporation

Akihabara UDX 15F,  
4-14-1, Sotokanda, Chiyoda-ku, Tokyo 101-0021, JAPAN  
Phone: 03-5207-8249 Fax: 03-5298-5362  
<https://www.smcworld.com>  
© 2022 SMC Corporation All Rights Reserved



D-G

④ Specifications are subject to change without prior notice and any obligation on the part of the manufacturer.