

Model with Residual Pressure Release Function

Pilot Check Valve Compact Type

New

RoHS

Model with Residual Pressure Release Function



Residual pressure exhaust button

Model without Residual Pressure Release Function



It is possible to construct a safety circuit!

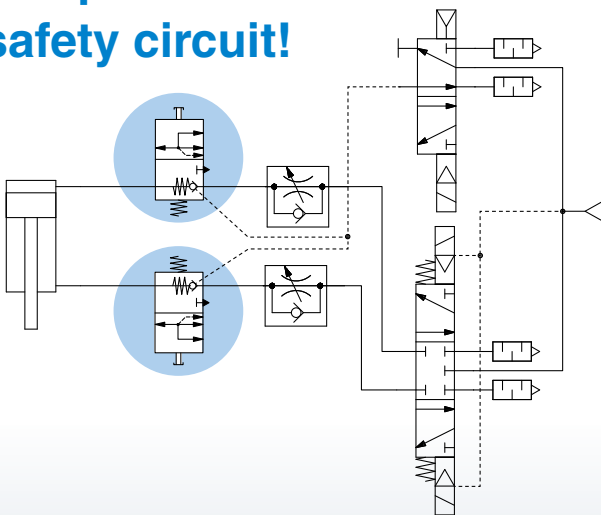

Temporary intermediate stops are possible.*1

*1 Precise intermediate stops are not guaranteed.

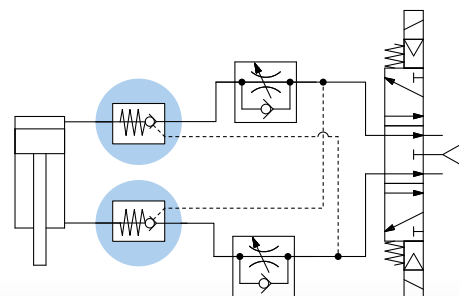

Variations

	Elbow	Universal	Port size	Pilot port size	Applicable tubing O.D.	
					Metric size	Inch size
Horizontal			1/8, 1/4 (R, NPT, G)	6, 8	4, 6, 8	5/32" 1/4" 5/16"
Vertical			1/8, 1/4 (G)	6, 8	4, 6, 8	—

AKP Series



CAT.ES20-274A

Vertical and horizontal types are available, which can be selected depending on the installation conditions.

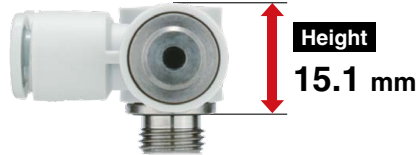
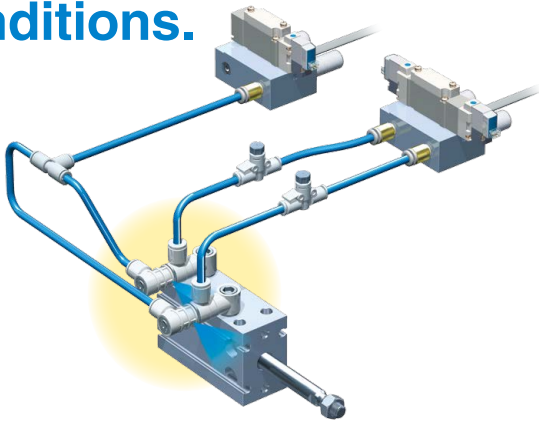

Horizontal Elbow type



Vertical Elbow type

Improved piping design flexibility (360°-rotation type)

Easily mounted using a hexagon wrench

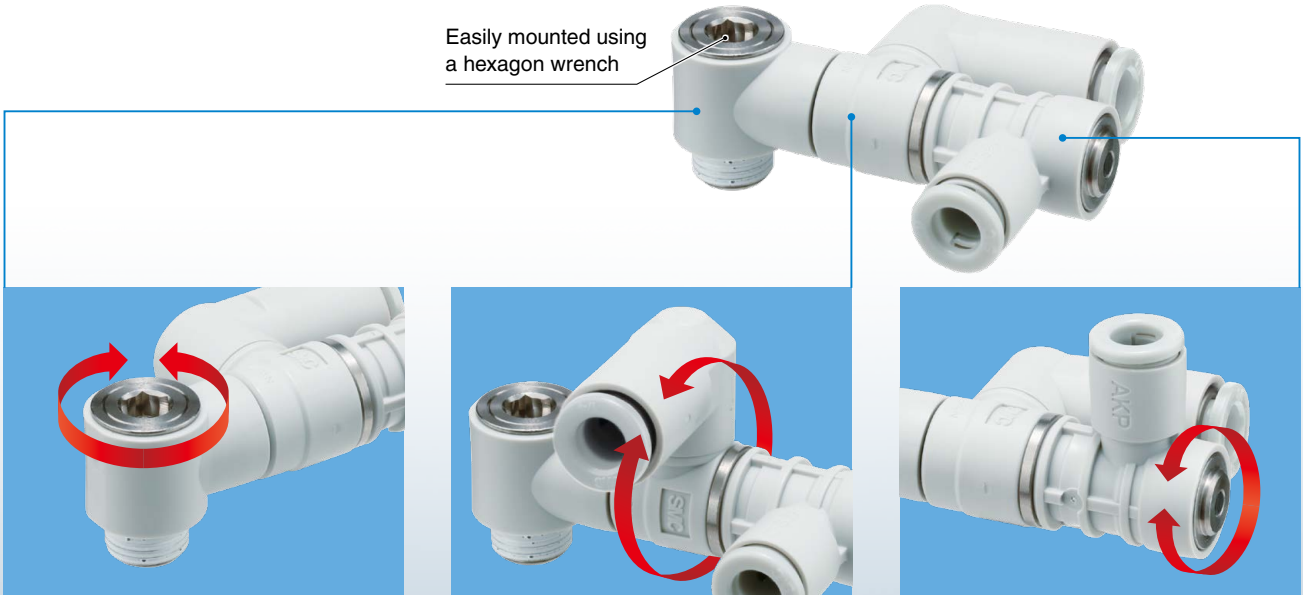

Model with Residual Pressure Release Function

Pilot Check Valve Compact Type

AKP Series

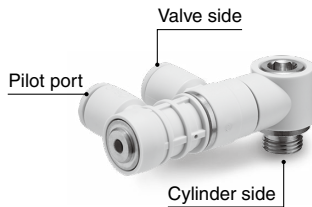
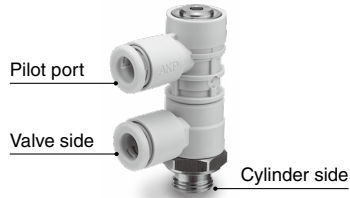

Model

Vertical type

Port size	Pilot port size	Applicable tubing O.D.					
		Metric size			Inch size		
		4	6	8	5/32"	1/4"	5/16"
G1/8	ø6	●	●	●	—	—	—
G1/4	ø8	—	●	●	—	—	—

Horizontal type

Port size	Pilot port size	Applicable tubing O.D.						
		Metric size			Inch size			
		4	6	8	5/32"	1/4"	5/16"	
R	1/8	ø6	●	●	●	—	—	—
NPT			—	—	—	●	●	—
G			●	●	●	—	—	—
R	1/4	ø8	—	●	●	—	—	—
NPT			—	—	—	—	●	●
G			—	●	●	—	—	—

Symbol

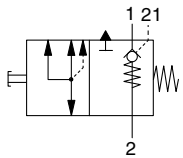

Model with residual pressure release function

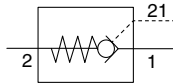

Model without residual pressure release function

Specifications

Fluid	Air
Proof pressure	1.05 MPa
Max. operating pressure	0.7 MPa
Min. operating pressure	0.1 MPa
Pilot check valve operating pressure	50% or more of the cylinder supply pressure (0.1 MPa or more)
Ambient and fluid temperatures	-5 to 60°C (No freezing)
Applicable tubing material	Nylon, Soft nylon, Polyurethane, FEP, PFA

* Use caution at the max. operating pressure when using soft nylon or polyurethane tubing. (Refer to the **Web Catalog** for details.)

Flow Rate and Sonic Conductance

Model		AKP-□-□01		AKP-□-□02	
Tubing O.D.	Metric size	ø4	ø6 ø8	ø6	ø8
	Inch size	ø5/32"	ø1/4"	ø1/4"	ø5/16"
C values: Sonic conductance dm ³ /(s·bar)	Free flow	0.51	0.68	1.17	1.29
	Controlled flow	0.51	0.68	1.17	1.29
b values: Critical pressure ratio	Free flow	0.35	0.25	0.45	0.45
	Controlled flow	0.40	0.25	0.40	0.40

⚠ Caution

Be sure to read this before handling the products. Refer to the back cover for safety instructions. For flow control equipment precautions, refer to the "Handling Precautions for SMC Products" and the "Operation Manual" on the SMC website: <https://www.smcworld.com>

How to Order



Vertical type

Vertical ●
AKP-L A 04 E - G 01



Horizontal type

AKP-L B 04 E - [] 01 S

● **Type**

L	Elbow
U	Universal

● **Seal method**

Nil	Without sealant
S	With sealant

* Face seal type is used for the G thread type.
 Select "Nil/Without sealant."
 Example) AKP-LA04E-G01

● **Horizontal**

● **Applicable tubing O.D.*1**

Metric size		Inch size*2	
04	ø4	03	ø5/32"
06	ø6	07	ø1/4"
08	ø8	09	ø5/16"

*1 For selecting applicable tubing O.D., refer to the "Model" on page 2.

*2 Only the metric size is available for the G thread type.

● **Port size**

01	1/8
02	1/4

● **Thread type**

Nil	R
N	NPT
G	G

● **Residual pressure release function**

Nil	Without
E	With

Construction

Horizontal Elbow type

Seal method: Sealant
For R, NPT

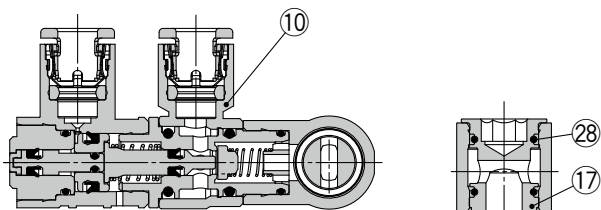

Model with residual pressure release function

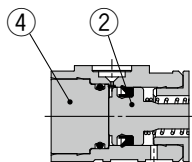

Model without residual pressure release function

Horizontal Universal type

Seal method: Sealant
For R, NPT

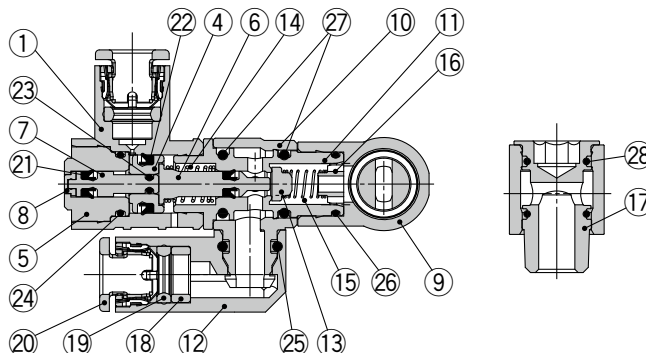

Model with residual pressure release function

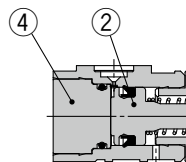

Model without residual pressure release function

Component Parts

No.	Description	Material	Note
1	Pilot body	PBT	
2	Piston A	Brass	Electroless nickel plating
3	Piston B	Brass	Electroless nickel plating
4	End cover A	Brass	Electroless nickel plating
5	End cover B	Brass	Electroless nickel plating
6	Piston rod	Brass	Electroless nickel plating
7	Push rod	Aluminum alloy	
8	Push rod cover	PBT	
9	End body	PBT	
10	Body A	PBT	
11	Body B	Brass	Electroless nickel plating
12	Elbow body	PBT	
13	Valve	NBR	
14	Spring	Stainless steel	
15	Spring	Stainless steel	

No.	Description	Material	Note
16	Guide	Brass	Electroless nickel plating
17	Stud	Brass	Electroless nickel plating
18	Spacer	POM/PBT	
19	Cassette seal	NBR	
20	Cassette	—	
21	DYP seal	NBR	
22	DYP seal	NBR	
23	O-ring	NBR	
24	O-ring	NBR	
25	O-ring	NBR	
26	O-ring	NBR	
27	O-ring	NBR	
28	O-ring	NBR	
29	Seal ring	NBR	

AKP Series

Construction

Vertical Elbow type

Seal method: Face seal
For G

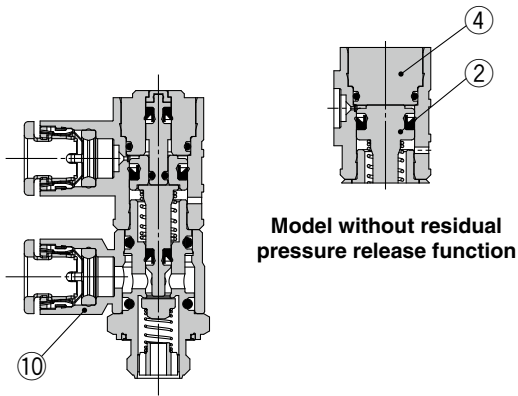

Model with residual pressure release function

Model without residual pressure release function

Vertical Universal type

Seal method: Face seal
For G

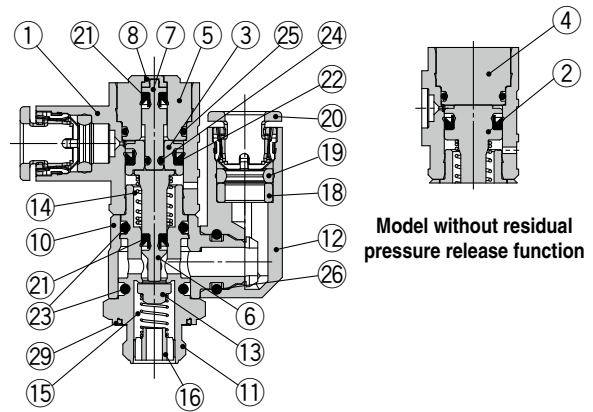

Model with residual pressure release function

Model without residual pressure release function

Horizontal Elbow type

Seal method: Face seal
For G

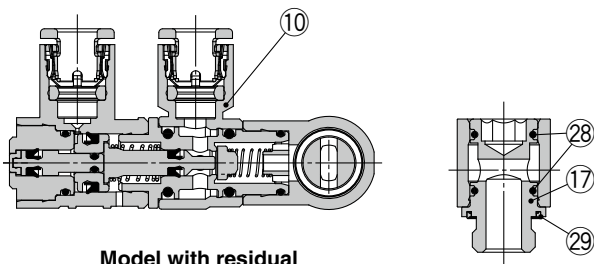

Model with residual pressure release function

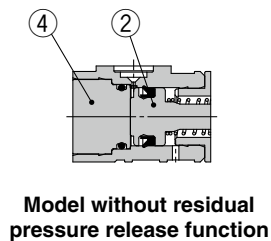

Model without residual pressure release function

Horizontal Universal type

Seal method: Face seal
For G

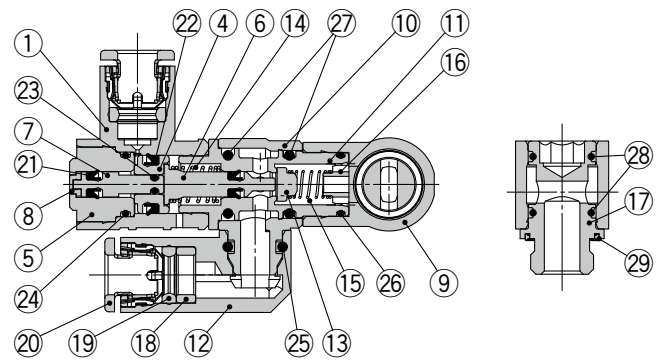

Model with residual pressure release function

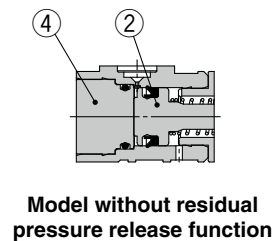

Model without residual pressure release function

Dimensions

Horizontal Elbow type

Seal method: Sealant
For R, NPT

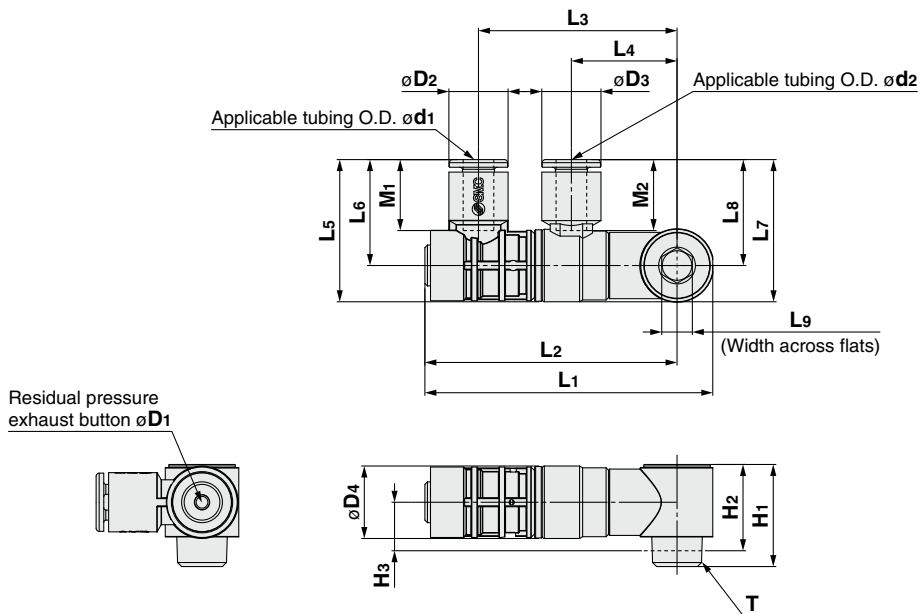

Metric Size

Model	d1	d2	T (R, NPT)	D1	D2	D3	D4	L1	L2	L3	L4	L5	L6	L7	L8	L9 (Width across flats)	H1	H2	H3	M1	M2	Weight [g]										
AKP-LB04E-01(S)	6	4	R1/8	2.9	11.6	9.3	14.2	56.4	49.4	38.9	20.7	27.9	20.8	27.5	20.4	6	20.0	16.9	9.5	13.9	12.7	35										
AKP-LB06E-01(S)	6	6				11.6								12.8	18.5						65.5	56.8	46.7	26.8	36.4	27.2	27.9	20.8	32.4	25.3	17.1	73
AKP-LB08E-01(S)	8	8				15.2								15.2	18.5						65.5	56.8	46.7	26.8	36.4	27.2	27.9	20.8	32.4	25.3	18.7	37
AKP-LB06E-02(S)	8	6	R1/4	—	15.2	12.8	18.5	64.6	55.9	46.7	26.8	36.4	27.2	34.8	25.5	8	30.0	25.3	14.8	18.7	17.1	73										
AKP-LB08E-02(S)	8	8				15.2								15.2	18.5						64.6	55.9	46.7	26.8	36.4	27.2	34.8	25.5	18.7	75		
AKP-LB04-01(S)	6	4	R1/8	—	11.6	9.3	14.2	55.3	48.3	38.9	20.7	27.9	20.8	27.5	20.4	6	20.0	16.9	9.5	13.9	12.7	35										
AKP-LB06-01(S)	6	6				11.6								12.8	18.5						64.6	55.9	46.7	26.8	36.4	27.2	27.9	20.8	32.4	25.3	17.1	37
AKP-LB08-01(S)	8	8				15.2								15.2	18.5						64.6	55.9	46.7	26.8	36.4	27.2	27.9	20.8	32.4	25.3	18.7	37
AKP-LB06-02(S)	8	6	R1/4	—	15.2	12.8	18.5	64.6	55.9	46.7	26.8	36.4	27.2	34.8	25.5	8	30.0	25.3	14.8	18.7	17.1	74										
AKP-LB08-02(S)	8	8				15.2								15.2	18.5						64.6	55.9	46.7	26.8	36.4	27.2	34.8	25.5	18.7	76		

Inch Size

Model	d1	d2	T (R, NPT)	D1	D2	D3	D4	L1	L2	L3	L4	L5	L6	L7	L8	L9 (Width across flats)	H1	H2	H3	M1	M2	Weight [g]
AKP-LB03E-N01(S)	6	5/32"	NPT1/8	2.9	11.6	9.3	14.2	56.4	49.4	38.9	20.7	27.9	20.8	27.5	20.4	5.56	20.0	16.8	9.4	13.9	12.7	35
AKP-LB07E-N01(S)	6	1/4"				11.6								13.2	18.5						65.5	56.8
AKP-LB07E-N02(S)	8	1/4"	NPT1/4	—	15.2	13.2	18.5	64.6	55.9	46.7	26.8	36.4	27.2	34.8	25.5	7.94	30.3	25.9	16.4	18.7	17.1	74
AKP-LB09E-N02(S)	8	5/16"				15.2								15.2	18.5						64.6	55.9
AKP-LB03-N01(S)	6	5/32"	NPT1/8	—	11.6	9.3	14.2	55.3	48.3	38.9	20.7	27.9	20.8	27.5	20.4	5.56	20.0	16.8	9.4	13.9	12.7	36
AKP-LB07-N01(S)	6	1/4"				11.6								13.2	18.5						64.6	55.9
AKP-LB07-N02(S)	8	1/4"	NPT1/4	—	15.2	13.2	18.5	64.6	55.9	46.7	26.8	36.4	27.2	34.8	25.5	7.94	30.3	25.9	16.4	18.7	17.1	75
AKP-LB09-N02(S)	8	5/16"				15.2								15.2	18.5						64.6	55.9

AKP Series

Dimensions

Horizontal Universal type

Seal method: Sealant
For R, NPT

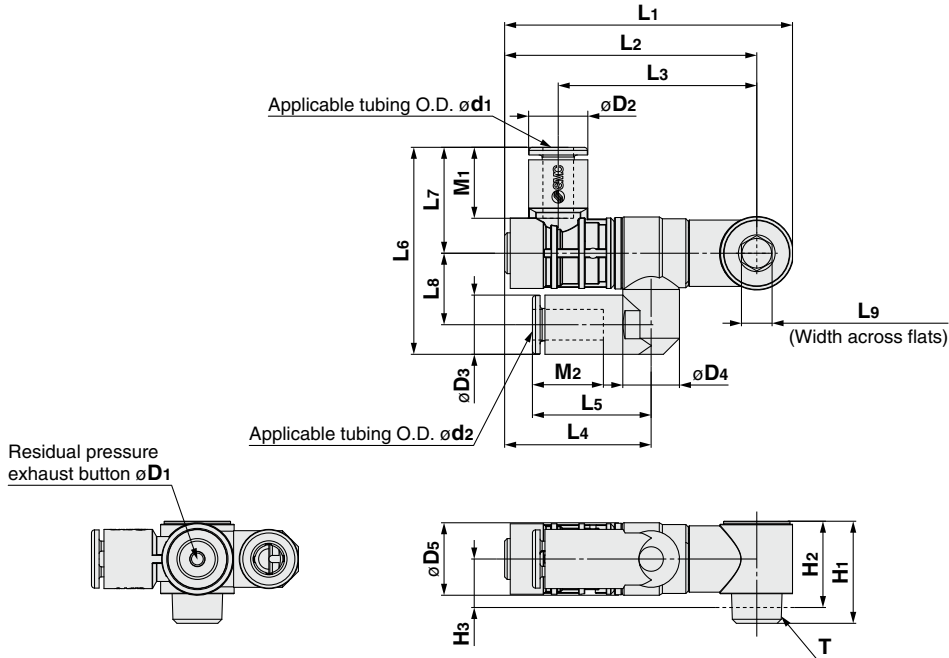
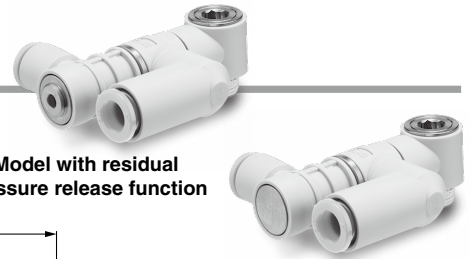

Metric Size

Model	d1	d2	T	D1	D2	D3	D4	D5	L1	L2	L3	L4	L5	L6	L7	L8	L9 (Width across flats)	H1	H2	H3	M1	M2	Weight [g]	
AKP-UB04E-01(S)	6	4	R1/8	2.9	11.6	9.3	9.3	14.2	56.4	49.4	38.9	28.7	17.5	38.5	20.8	13.1	6	20.0	16.9	9.5	13.9	12.9	36	
AKP-UB06E-01(S)		6				11.6	11.6						11.1	23.2		40.5						14.0	14.1	36
AKP-UB08E-01(S)		8				15.2	12.9						29.5	28.2		44.5						16.2	18.7	39
AKP-UB06E-02(S)	8	6	R1/4	15.2	12.8	12.9	18.5	65.5	56.8	46.7	30.8	25.5	52.0	27.2	18.4	8	30.0	25.3	14.8	18.7	17.1	75		
AKP-UB08E-02(S)		8										15.2	28.2								53.2	27.2	18.4	18.7
AKP-UB04-01(S)	6	4	R1/8	—	11.6	9.3	9.3	14.2	55.3	48.3	38.9	27.6	17.5	38.5	20.8	13.1	6	20.0	16.9	9.5	13.9	12.9	37	
AKP-UB06-01(S)		6				11.6	11.6						11.1	23.2		40.5						14.0	14.1	37
AKP-UB08-01(S)		8				15.2	12.9						28.4	28.2		44.5						16.2	18.7	40
AKP-UB06-02(S)	8	6	R1/4	15.2	12.8	12.9	18.5	64.6	55.9	46.7	29.9	25.5	52.0	27.2	18.4	8	30.0	25.3	14.8	18.7	17.1	76		
AKP-UB08-02(S)		8										15.2	28.2								53.2	27.2	18.4	18.7

Inch Size

Model	d1	d2	T	D1	D2	D3	D4	D5	L1	L2	L3	L4	L5	L6	L7	L8	L9 (Width across flats)	H1	H2	H3	M1	M2	Weight [g]	
AKP-UB03E-N01(S)	6	5/32"	NPT1/8	2.9	11.6	9.3	9.3	14.2	56.4	49.4	38.9	28.7	17.5	38.5	20.8	13.1	5.56	20.0	16.8	9.4	13.9	12.9	37	
AKP-UB07E-N01(S)		1/4"				13.2	12.9						29.5	25.9		43.5						16.2	17.1	37
AKP-UB07E-N02(S)		8				15.2	12.9						18.5	65.5		56.8						46.7	30.8	25.9
AKP-UB09E-N02(S)	8	5/16"	NPT1/4	15.2	15.2	12.9	18.5	64.6	55.9	46.7	29.9	28.2	53.2	27.2	18.4	8	30.0	25.3	14.8	18.7	18.7	80		
AKP-UB03-N01(S)	6	5/32"	NPT1/8	—	11.6	9.3	9.3	14.2	55.3	48.3	38.9	27.6	17.5	38.5	20.8	13.1	5.56	20.0	16.8	9.4	13.9	12.9	37	
AKP-UB07-N01(S)		1/4"				13.2	12.9						28.4	25.9		43.5						16.2	17.1	37
AKP-UB07-N02(S)		8				15.2	12.9						18.5	64.6		55.9						46.7	29.9	25.9
AKP-UB09-N02(S)	8	5/16"	NPT1/4	15.2	15.2	12.9	18.5	64.6	55.9	46.7	29.9	28.2	53.2	27.2	18.4	8	30.0	25.3	14.8	18.7	18.7	80		

Dimensions

Horizontal Elbow type

Seal method: Face seal
For G

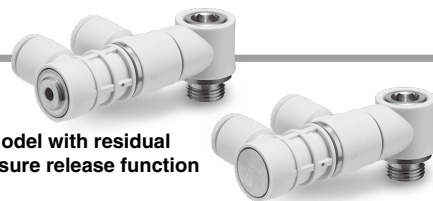
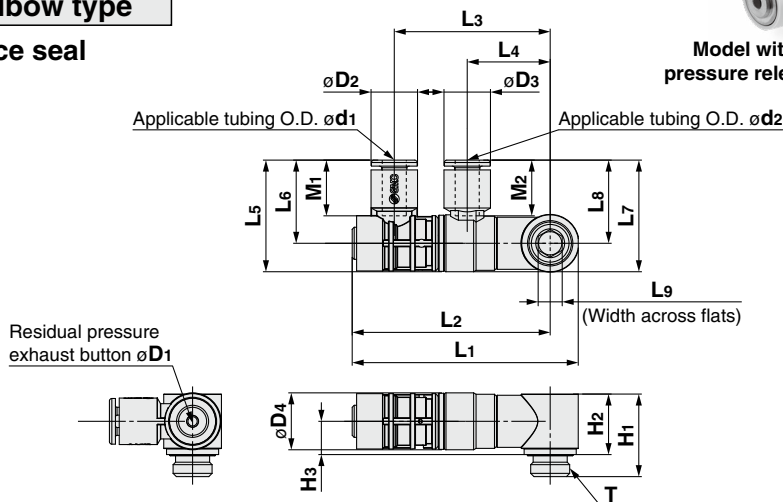

Model without residual pressure release function

Metric Size

Model	d1	d2	T (R, NPT)	D1	D2	D3	D4	L1	L2	L3	L4	L5	L6	L7	L8	L9 (Width across flats)	H1	H2	H3	M1	M2	Weight [g]	
AKP-LB04E-G01	6	4	G1/8	2.9	11.6	9.3	14.2	56.4	49.4	38.9	20.7	27.9	20.8	27.5	20.4	6	20.6	15.1	8.3	13.9	12.7	35	
AKP-LB06E-G01		6				11.6								14.2	27.9						20.8	13.9	35
AKP-LB08E-G01		8				15.2								18.5	27.9						20.8	18.7	37
AKP-LB06E-G02	8	6	G1/4	15.2	12.8	15.2	18.5	65.5	56.8	46.7	26.8	36.4	27.2	34.8	25.5	8	27.8	21.3	11.8	18.7	17.1	71	
AKP-LB08E-G02		8												15.2	18.5						27.2	18.7	73
AKP-LB04-G01		4												9.3	14.2						27.2	18.7	73
AKP-LB06-G01	6	6	G1/8	—	11.6	9.3	14.2	55.3	48.3	38.9	20.7	27.9	20.8	27.5	20.4	6	20.6	15.1	8.3	13.9	12.7	35	
AKP-LB08-G01		8				11.6								14.2	27.9						20.8	13.9	35
AKP-LB06-G02		6				11.6								14.2	27.9						20.8	13.9	35
AKP-LB08-G02	8	6	G1/4	15.2	12.8	15.2	18.5	64.6	55.9	46.7	26.8	36.4	27.2	34.8	25.5	8	27.8	21.3	11.8	18.7	17.1	72	
AKP-LB08-G02		8												15.2	18.5						27.2	18.7	74

Horizontal Universal type

Seal method: Face seal
For G

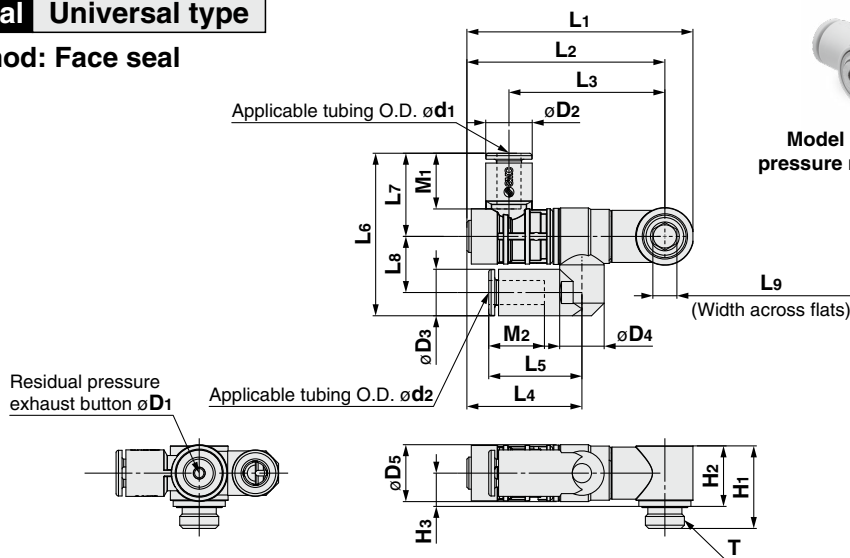

Model without residual pressure release function

Metric Size

Model	d1	d2	T	D1	D2	D3	D4	D5	L1	L2	L3	L4	L5	L6	L7	L8	L9 (Width across flats)	H1	H2	H3	M1	M2	Weight [g]					
AKP-UB04E-G01	6	4	G1/8	2.9	11.6	9.3	9.3	14.2	56.4	49.4	38.9	28.7	17.5	38.5	13.1	13.1	6	20.6	15.1	8.3	13.9	12.9	36					
AKP-UB06E-G01		6				11.6	11.1															14.2	28.7	17.5	38.5	12.9	36	
AKP-UB08E-G01		8				15.2	12.9															14.2	28.7	17.5	38.5	18.7	39	
AKP-UB06E-G02	8	6	G1/4	15.2	12.8	12.9	18.5	65.5	56.8	46.7	30.8	25.5	52.0	27.2	18.4	18.4	8	27.8	21.3	11.8	18.7	17.1	73					
AKP-UB08E-G02		8																				15.2	12.9	14.2	27.2	18.4	18.7	76
AKP-UB04-G01		4																				9.3	9.3	14.2	27.2	18.4	18.7	76
AKP-UB06-G01	6	6	G1/8	—	11.6	9.3	9.3	14.2	55.3	48.3	38.9	27.6	17.5	38.5	13.1	13.1	6	20.6	15.1	8.3	13.9	12.9	37					
AKP-UB08-G01		8				11.6	11.1															14.2	27.6	17.5	38.5	14.1	37	
AKP-UB06-G02		6				11.6	11.1															14.2	27.6	17.5	38.5	14.1	37	
AKP-UB08-G02	8	6	G1/4	15.2	12.8	12.9	18.5	64.6	55.9	46.7	29.9	25.5	52.0	27.2	18.4	18.4	8	27.8	21.3	11.8	18.7	17.1	73					
AKP-UB08-G02		8																				15.2	12.9	14.2	27.2	18.4	18.7	76

AKP Series

Dimensions

Vertical Elbow type

Seal method: Face seal
For G

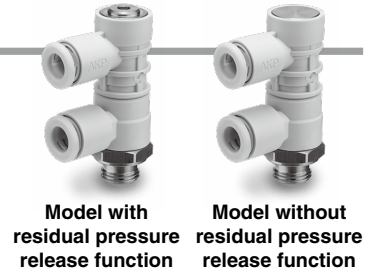
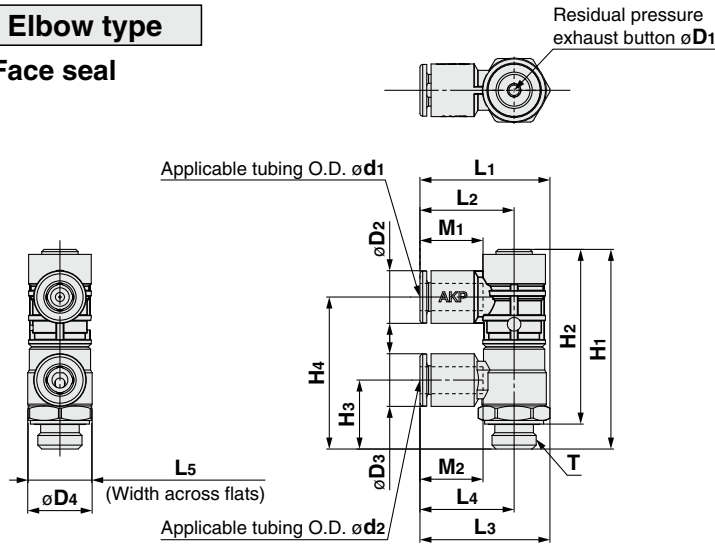

Metric Size

Model	d1	d2	T	D1	D2	D3	D4	L1	L2	L3	L4	L5 (Width across flats)	H1	H2	H3	H4	M1	M2	Weight [g]	
AKP-LA04E-G01	6	4	G1/8	2.9	11.6	9.3	14.2	28.6	20.8	28.3	20.4	14	44.0	38.5	15.2	33.5	13.9	12.7	27	
AKP-LA06E-G01		6				11.6				28.6	20.8							13.9	13.9	27
AKP-LA08E-G01		8				15.2				33.2	25.3							18.7	29	
AKP-LA06E-G02	8	6	G1/4	—	15.2	12.8	18.5	37.5	27.2	35.8	25.5	19	48.1	41.6	17.1	38.0	18.7	17.1	52	
AKP-LA08E-G02		8				15.2				37.5	27.2							18.7	18.7	53
AKP-LA04-G01		4				9.3				28.3	20.4							12.7	27	
AKP-LA06-G01	6	6	G1/8	—	11.6	11.6	14.2	28.6	20.8	28.6	20.8	14	42.9	37.4	15.2	33.5	13.9	13.9	27	
AKP-LA08-G01		8				15.2				33.2	25.3							18.7	29	
AKP-LA06-G02		6				12.8				35.8	25.5							17.1	50	
AKP-LA08-G02	8	15.2	37.5	27.2	18.7	18.7	52													

Vertical Universal type

Seal method: Face seal
For G

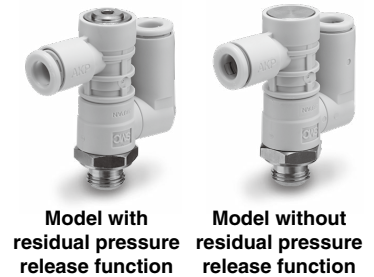
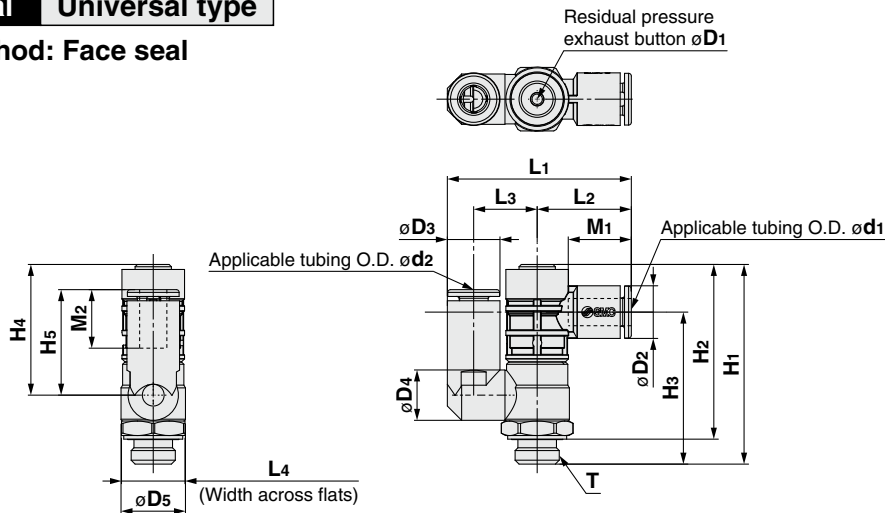

Metric Size

Model	d1	d2	T	D1	D2	D3	D4	D5	L1	L2	L3	L4 (Width across flats)	H1	H2	H3	H4	H5	M1	M2	Weight [g]
AKP-UA04E-G01	6	4	G1/8	2.9	11.6	9.3	9.3	14.2	38.5	20.8	13.1	14	44.0	38.5	33.5	28.8	17.5	13.9	12.9	28
AKP-UA06E-G01		6				11.6	11.1		40.5		14.0						23.2		14.1	28
AKP-UA08E-G01		8				15.2	44.5		16.2		18.7						31			
AKP-UA06E-G02	8	6	G1/4	—	15.2	12.8	12.9	18.5	52.0	27.2	18.4	19	48.1	41.6	38.0	30.2	25.5	18.7	17.1	51
AKP-UA08E-G02		8				15.2	53.2		18.7		18.7						54			
AKP-UA04-G01		4				9.3	38.5		13.1		12.9						29			
AKP-UA06-G01	6	6	G1/8	—	11.6	11.6	11.1	14.2	40.5	20.8	14.0	14	42.9	37.4	33.5	27.7	23.2	13.9	14.1	29
AKP-UA08-G01		8				15.2	44.5		16.2		18.7						32			
AKP-UA06-G02		6				12.8	52.0		18.4		17.1						51			
AKP-UA08-G02	8	15.2	53.2	27.2	18.7	18.7	54													



AKP Series Specific Product Precautions 1

Be sure to read this before handling the products. Refer to the back cover for safety instructions. For flow control equipment precautions, refer to the “Handling Precautions for SMC Products” and the “Operation Manual” on the SMC website: <https://www.smcworld.com>

Design

Warning

1. Confirm the specifications.

The products in this catalog are designed to be used in compressed air systems (including vacuum) only.

Do not operate at pressures, temperatures, etc., beyond the range of specifications, as this can cause damage or malfunction. (Refer to the specifications.)

Please contact SMC when using a fluid other than compressed air (including vacuum).

We do not guarantee against any damage if the product is used outside of the specification range.

2. Do not disassemble the product or make any modifications, including additional machining.

Doing so may cause human injury and/or an accident.

3. Sonic conductance (C) and critical pressure ratio (b) values for products are representative values.

4. Check if PTFE can be used in the application.

PTFE powder (Polytetrafluoroethylene resin) is included in the seal material of the male thread type piping taper thread.

Confirm that the use of it will not cause any adverse effects on the system.

Please contact SMC if the Safety Data Sheet (SDS) is required.

5. The pilot check valve is a product aimed at the control of the actuator via a temporary intermediate stop.

The pilot check valve is used for temporarily stopping the actuator. Until a pilot signal is input, the valve shuts off the flow path from 2 to 1 and the actuator stops. When a pilot signal is input, the flow path from 2 to 1 is opened. When the residual pressure exhaust button is operated, all flow paths (2 to 1, 21, and exhaust port) are opened.

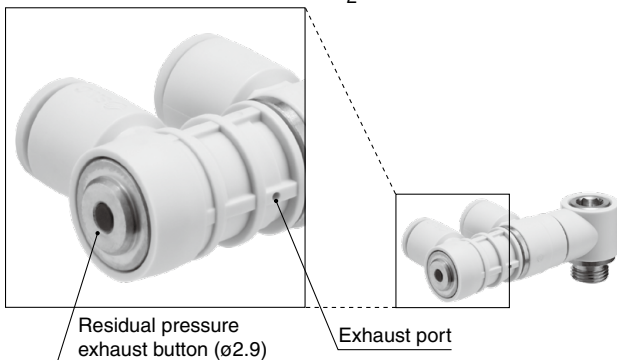
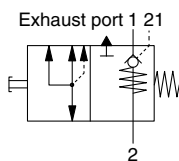

6. This product cannot be used for accurate and precise intermediate stops of the actuator.

Due to the compressibility of air as a fluid, the actuator will continue to move until it reaches a position of pressure balance, even though the pilot check valve closes with an intermediate stop signal.

7. This product cannot be used to hold a stop position for an extended period of time.

Pilot check valves and actuators are not guaranteed for zero air leakage. Therefore, it is sometimes not possible to hold a stop position for an extended period of time. In the event that holding for an extended time is necessary, a mechanical means for holding should be devised.

8. Pay attention to the residual pressure within the actuator at the time of intermediate stop.

When the actuator is stopped at the intermediate position by this product, there may be pressure contained inside the actuator, therefore the actuator may suddenly move when the residual pressure is released. Before operating the residual pressure exhaust button, confirm that the surrounding area is secure from any potential hazards or accidents occurring.

9. Use this product after checking the surrounding areas in advance before the release of residual pressure.

The actuator may move at a speed quicker than the intended speed from the original circuit set up when exhausting from the residual pressure release. Confirm this speed will not create additional hazards and pay attention to the air discharged from the exhaust port.

10. Pay attention to the motion of the actuator at the time of release of the residual pressure.

When operating the manual button or conducting maintenance or inspection, the actuator may start moving due to the residual pressure. Take appropriate measures in advance to prevent an actuator movement from posing a hazard.

Also pay attention to the operation speed and the movement of the cylinder during exhaust.

When an exhaust center valve is used on the actuator supply side (Figure A below), the residual pressure is released from port 1, 21, and the exhaust port. However, when using a closed center valve like the example shown in Figure B on page 11, air is discharged only from port 21 and the exhaust port.

For the moving direction of the actuator against the corresponding exhaust side, refer to the figure below.

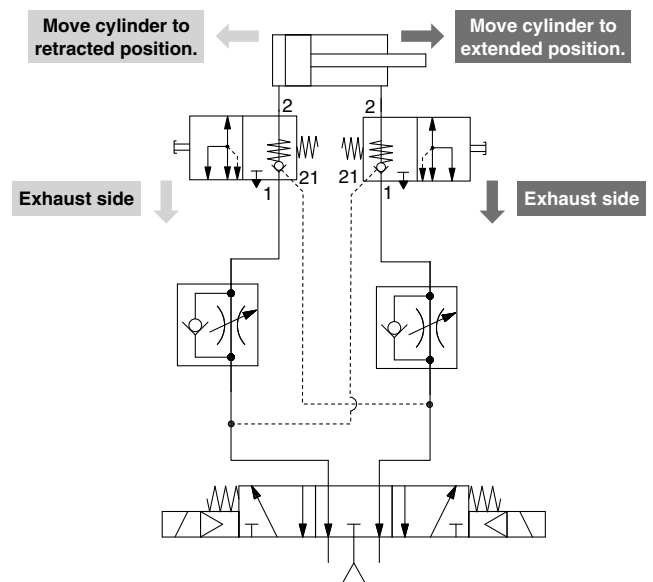

Figure A: Example of piping using exhaust center valve



AKP Series Specific Product Precautions 2

Be sure to read this before handling the products. Refer to the back cover for safety instructions. For flow control equipment precautions, refer to the “Handling Precautions for SMC Products” and the “Operation Manual” on the SMC website: <https://www.smcworld.com>

Design

Warning

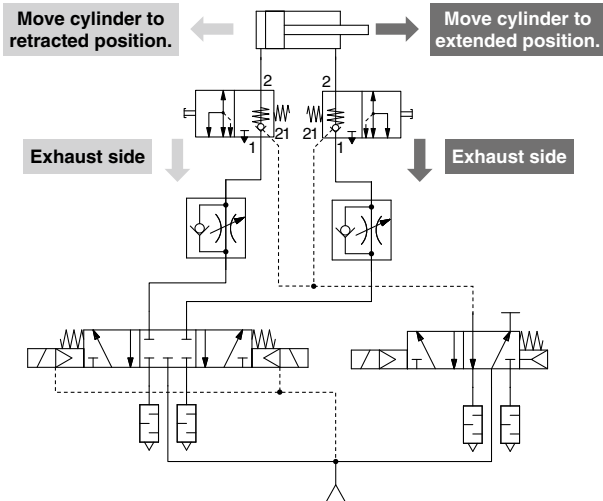

Figure B: Example of piping using closed center valve (Recommended example)

11. Push the manual button all the way to the end position by using a tool.

Push the manual button all the way to the end position by using a tool having a tip diameter of $\phi 2.8$ or below. For the insertion depth and insertion force, refer to the table below.

Operating pressure [MPa]	Insertion force [N] (Reference value)		Insertion depth [mm] (Reference value)
	AKP-□-□01	AKP-□-□02	
0.1	5.1	6.6	2.4
0.3	7.5	11.3	
0.5	10.0	16.0	
0.7	12.4	20.8	

12. After operating the manual button, confirm that the button has returned to the normal position.

Make sure that the manual button has returned to the end face of the product before operating again. If the button cannot return to the normal position, the intermediate stop function of the actuator will not work. Therefore, replace the product with a new one.

13. Pay attention to the motion of the actuator at the time of restart after the release of residual pressure.

When restarting the product after releasing the residual pressure, check the initial driving direction, confirm that the work area is secured, and then restart the product. Failure to follow this instruction may cause the actuator to suddenly move.

14. When the product is used in a balance control circuit, the check valve may not be released even when the pilot pressure is 50% of the operating pressure. In this case, obtain the pilot pressure from a position so that the pilot pressure is equivalent to the operating pressure.

When using the product at the minimum operating pressure, set the pilot pressure to 0.1 MPa or higher.

15. As a reference, we have confirmed through our durability tests that the check valve has a durability against 10 million cycles of ON and OFF operations and the residual pressure exhaust button has a durability against 10,000 cycles of operation at the maximum operating pressure.

However, note that the tests were conducted under limited conditions.

16. In the following cases, malfunctioning or noise due to oscillation may occur.

- When the differential pressure between the port 1 side and port 2 side is smaller than the min. operating pressure
- When the IN side piping of the product or the effective area of the directional control valve is smaller than that of the product
- When the pressure drop on the port 1 side is slower than that of the port 2 side during operation of the product
- When the supply pressure at the port 21 is reduced (Refer to the piping diagram below.)
- When the port 1 side piping (tube) is bent or crushed

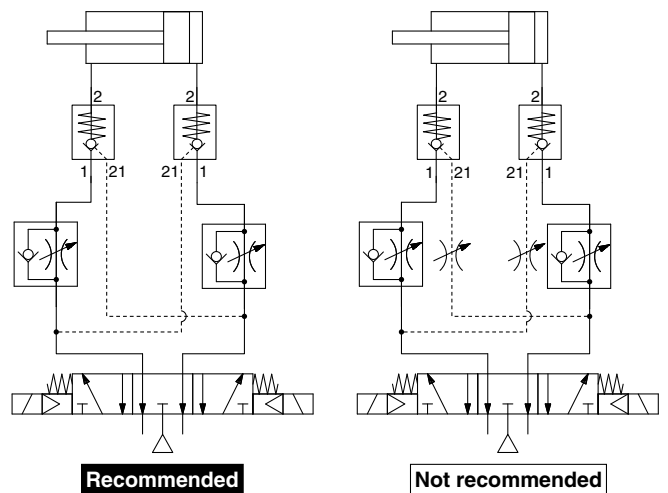



AKP Series

Specific Product Precautions 3

Be sure to read this before handling the products. Refer to the back cover for safety instructions. For flow control equipment precautions, refer to the "Handling Precautions for SMC Products" and the "Operation Manual" on the SMC website: <https://www.smcworld.com>

Mounting

Warning

1. Operation manual

Install the product and operate it only after reading the operation manual carefully and understanding its contents. Also, keep the manual where it can be referred to as necessary.

2. Ensure sufficient space for maintenance activities.

When installing the products, allow access for maintenance and inspection.

3. Tighten threads with the proper tightening torque.

When installing the products, follow the listed torque specifications.

4. Screw the R screw into the Rc thread, the NPT screw into the NPT thread and the G screw into the G thread.

5. Mount after confirming the piping direction.

Connect the IN side to the directional control valve and OUT side to the actuator.

6. Do not apply excessive force or shock to the cover (pilot port portion), fittings, or other parts of the product with tools. Also, do not apply any moment, twisting, pulling, or other external force when connecting a fitting to the cover (pilot port portion) or after mounting.

Doing so may result in damage or air leakage.

When connecting piping, use a tube of sufficient length, in accordance with the recommended piping conditions described in Fig. 1 on page 14. When binding the piping together with a tying band, etc., be sure that external force is not being applied to the piping. (Refer to Fig. 2 on page 14.)

7. Refer to the Fittings and Tubing Precautions in the Web Catalog for handling One-touch fittings.

8. To install and remove the product with hexagonal hole, use an appropriate hex key and push it into the hexagon hole of the stud.

Do not apply torque at other points, as the product may be damaged. Rotate Body A or B manually for positioning after installation. Refer to the applicable dimension of the hexagon wrench.

Connection thread size	Hexagon wrench (Nominal width across flats)	
	Metric size	Inch size
R1/8, G1/8	6	—
NPT1/8	—	7/32"
R1/4, G1/4	8	—
NPT1/4	—	5/16"

9. Do not use this product in the operating condition where moment loads will be constantly applied to the product.

The fitting section and the product may be damaged.

Caution

R, NPT and G Thread

1) Tightening method

When tightening the stud, insert an appropriate hexagon wrench to the hexagonal hole after tightening it by hand.

Use the tightening torque shown in the table below as a guide.

Connection thread size	Proper tightening torque [N·m]
1/8	3 to 5
1/4	8 to 12

2) Chamfered area for female thread

By chamfering as shown in the following table, machining of threads is easier and effective for burr prevention.

Connection thread size	Chamfer dimension ϕD (Recommended value)		
	Rc	NPT	G
1/8	10.2 to 10.4	10.5 to 10.7	9.8 to 10.2
1/4	13.6 to 13.8	14.1 to 14.3	13.3 to 13.7

* G thread (face seal) complies with ISO 16030-2001.

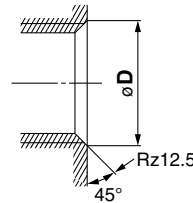



AKP Series

Specific Product Precautions 4

Be sure to read this before handling the products. Refer to the back cover for safety instructions. For flow control equipment precautions, refer to the “Handling Precautions for SMC Products” and the “Operation Manual” on the SMC website: <https://www.smcworld.com>

Piping Threads with Sealant

⚠ Caution

1. If the fitting is tightened with excessive torque, a large amount of sealant will seep out. Remove the excess sealant.
2. Insufficient tightening may loosen the threads or cause air leakage.
3. For reuse
 - 1) Normally, fittings with a sealant can be reused up to 2 to 3 times.
 - 2) To prevent air leakage through the sealant, remove any loose sealant stuck to the fitting by blowing air over the threaded portion.
 - 3) If the sealant no longer provides effective sealing, wind sealant tape over the sealant before reusing. Do not use any form other than the tape type of sealant.
4. Once the fitting has been tightened, backing it out to its original position often causes the sealant to become defective. Air leakage will occur.
5. Use R external threads with Rc internal threads and NPT external threads with NPT internal threads.
6. Winding of sealant tape

When screwing piping or fittings into ports, ensure that chips from the pipe threads or sealing material do not enter the piping. Also, if sealant tape is used, leave 1 thread ridge exposed at the end of the threads.

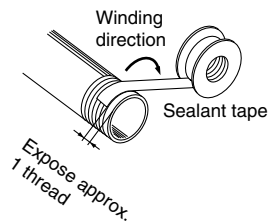

Piping

⚠ Caution

1. Refer to the Fittings and Tubing Precautions in the Web Catalog for handling One-touch fittings.
2. Preparation before piping

Before piping is connected, it should be thoroughly blown out with air (flushing) or washed to remove chips, cutting oil, and other debris from inside the pipe.

One-touch Fittings Mounting / Piping

⚠ Caution

1. Installation and removal of tubing for One-touch fittings

1) Installation of tubing

- (1) Cut the tubing perpendicularly, being careful not to damage the outside surface. Use an SMC tube cutter TK-1, 2, or 3. Do not cut the tubing with pliers, nippers, scissors, etc., otherwise the tubing will be deformed and problems may result.
- (2) The outside diameter of the polyurethane tubing swells when internal pressure is applied to it. Therefore, it may be impossible to re-insert the tubing into the One-touch fitting. Check the tubing outside diameter, and when the accuracy of the outside diameter is +0.07 mm or larger for $\varnothing 2$, +0.15 mm or larger for other sizes, re-insert it into the One-touch fitting without cutting the tubing. When the tubing is re-inserted into the One-touch fitting, confirm that the tubing goes through the release button smoothly.
- (3) Grasp the tube and push it in slowly, inserting it securely all the way into the fitting.
- (4) Pull the tubing back gently to make sure it has a positive seal. Insufficient installation may cause air to leak or the tubing to release.

2) Removal of tubing

- (1) Push the release button flange evenly and sufficiently to release the tube.
- (2) Pull out the tubing while keeping the release button depressed. If the release button is not held down sufficiently, the tubing cannot be withdrawn.
- (3) To reuse the tubing, remove the previously lodged portion of the tubing. If the lodged portion is left on without being removed, it may result in air leakage and make the removal of the tubing difficult.

2. Connecting products with metal rods

After attaching products with attached metal rods such as the KC series, to the One-touch fitting, please do not use tubes, resin plugs, or reducers, etc. This may cause releasing.

3. When attaching tubes, resin plugs, metal rods, etc., do not push the release button while attaching.

Also, do not push the release button before attaching. This may cause releasing.



AKP Series

Specific Product Precautions 5

Be sure to read this before handling the products. Refer to the back cover for safety instructions. For flow control equipment precautions, refer to the "Handling Precautions for SMC Products" and the "Operation Manual" on the SMC website: <https://www.smcworld.com>

Recommended Piping Conditions

1. When connecting piping to the One-touch fitting, use a pipe length with sufficient margin, in accordance with the piping conditions shown in Fig. 1.

Also, when using a tying band, etc., to bind the piping together, make sure that external force does not come to bear on the fitting. (See Fig. 2.)

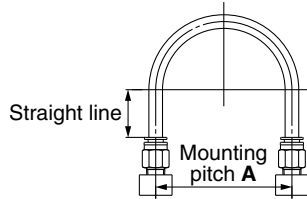

Fig. 1 Recommended piping

Unit: [mm]

Tubing size	Mounting pitch A			Straight line length
	Nylon tubing	Soft nylon tubing	Polyurethane tubing	
ø4, 5/32"	56 or more	44 or more	26 or more	20 or more
ø6	84 or more	66 or more	39 or more	30 or more
ø1/4"	89 or more	70 or more	57 or more	32 or more
ø8, 5/16"	112 or more	88 or more	52 or more	40 or more

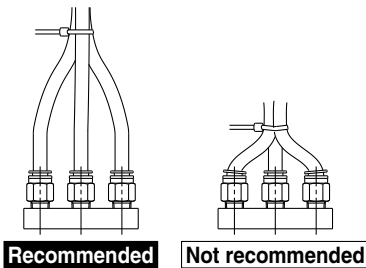

Fig. 2 When using a tying band to bind the piping together

Air Supply

Warning

1. **Type of fluids**
Please consult with SMC when using the product in applications other than compressed air.
2. **When there is a large amount of drainage**
Compressed air containing a large amount of drainage can cause the malfunction of pneumatic equipment. An air dryer or water separator should be installed upstream from filters.
3. **Drain flushing**
If condensation in the drain bowl is not emptied on a regular basis, the bowl will overflow and allow the condensation to enter the compressed air lines. This causes the malfunction of pneumatic equipment.
If the drain bowl is difficult to check and remove, the installation of a drain bowl with an auto drain option is recommended.
For compressed air quality, refer to the **Web Catalog**.
4. **Use clean air.**
Do not use compressed air that contains chemicals, synthetic oils that include organic solvents, salt, corrosive gases, etc., as it can cause damage or malfunction.

Air Supply

Caution

1. **Install an air filter.**

Install an air filter upstream near the valve.

For the filtration rating, select 5 µm or below, or select a rating equivalent to or lower than ISO 8573-1:2010 [6:4:4]*1.

*1 This is equivalent to the filtration performance achieved when an air filter is attached for inlet side compressed air with purity class of [7:4:4].

2. **Ensure that the fluid and ambient temperatures are within the specified range.**

If the fluid temperature is 5°C or less, the moisture in the circuit could freeze, causing damage to the seals or leading to equipment malfunction. Therefore, take appropriate measures to prevent freezing.

For compressed air quality, refer to the **Web Catalog**.

Operating Environment

Warning

1. **Do not use in an atmosphere containing corrosive gases, chemicals, sea water, water, water steam, or where there is direct contact with any of these.**
2. **Do not expose the product to direct sunlight for an extended period of time.**
3. **Do not mount the product in locations where it is exposed to radiant heat.**

Maintenance

Warning

1. **Perform maintenance and inspection according to the procedures indicated in the operation manual.**
If handled improperly, malfunction or damage of machinery and equipment may occur.
2. **Maintenance work**
If handled improperly, compressed air can be dangerous. Assembly, handling, repair, and element replacement of pneumatic systems should be performed by a knowledgeable and experienced person.
3. **Drain flushing**
Remove drainage from air filters regularly.
4. **Removal of equipment, and supply/exhaust of compressed air**
Before components are removed, first confirm that measures are in place to prevent workpieces from dropping, run-away equipment, etc. Then, cut off the supply pressure and electric power, and exhaust all compressed air from the system using the residual pressure release function. When machinery is restarted, proceed with caution after confirming that appropriate measures are in place to prevent sudden movement.

Safety Instructions

These safety instructions are intended to prevent hazardous situations and/or equipment damage. These instructions indicate the level of potential hazard with the labels of “**Caution**,” “**Warning**” or “**Danger**.” They are all important notes for safety and must be followed in addition to International Standards (ISO/IEC)*1), and other safety regulations.

 **Caution:** **Caution** indicates a hazard with a low level of risk which, if not avoided, could result in minor or moderate injury.

 **Warning:** **Warning** indicates a hazard with a medium level of risk which, if not avoided, could result in death or serious injury.

 **Danger :** **Danger** indicates a hazard with a high level of risk which, if not avoided, will result in death or serious injury.

*1) ISO 4414: Pneumatic fluid power – General rules relating to systems.
ISO 4413: Hydraulic fluid power – General rules relating to systems.
IEC 60204-1: Safety of machinery – Electrical equipment of machines.
(Part 1: General requirements)
ISO 10218-1: Manipulating industrial robots – Safety.
etc.

Warning

1. The compatibility of the product is the responsibility of the person who designs the equipment or decides its specifications.

Since the product specified here is used under various operating conditions, its compatibility with specific equipment must be decided by the person who designs the equipment or decides its specifications based on necessary analysis and test results. The expected performance and safety assurance of the equipment will be the responsibility of the person who has determined its compatibility with the product. This person should also continuously review all specifications of the product referring to its latest catalog information, with a view to giving due consideration to any possibility of equipment failure when configuring the equipment.

2. Only personnel with appropriate training should operate machinery and equipment.

The product specified here may become unsafe if handled incorrectly. The assembly, operation and maintenance of machines or equipment including our products must be performed by an operator who is appropriately trained and experienced.

3. Do not service or attempt to remove product and machinery/equipment until safety is confirmed.

1. The inspection and maintenance of machinery/equipment should only be performed after measures to prevent falling or runaway of the driven objects have been confirmed.
2. When the product is to be removed, confirm that the safety measures as mentioned above are implemented and the power from any appropriate source is cut, and read and understand the specific product precautions of all relevant products carefully.
3. Before machinery/equipment is restarted, take measures to prevent unexpected operation and malfunction.

4. Contact SMC beforehand and take special consideration of safety measures if the product is to be used in any of the following conditions.

1. Conditions and environments outside of the given specifications, or use outdoors or in a place exposed to direct sunlight.
2. Installation on equipment in conjunction with atomic energy, railways, air navigation, space, shipping, vehicles, military, medical treatment, combustion and recreation, or equipment in contact with food and beverages, emergency stop circuits, clutch and brake circuits in press applications, safety equipment or other applications unsuitable for the standard specifications described in the product catalog.
3. An application which could have negative effects on people, property, or animals requiring special safety analysis.
4. Use in an interlock circuit, which requires the provision of double interlock for possible failure by using a mechanical protective function, and periodical checks to confirm proper operation.

Caution

1. The product is provided for use in manufacturing industries.

The product herein described is basically provided for peaceful use in manufacturing industries.
If considering using the product in other industries, consult SMC beforehand and exchange specifications or a contract if necessary.
If anything is unclear, contact your nearest sales branch.

Limited warranty and Disclaimer/ Compliance Requirements

The product used is subject to the following “Limited warranty and Disclaimer” and “Compliance Requirements”.

Read and accept them before using the product.

Limited warranty and Disclaimer

1. The warranty period of the product is 1 year in service or 1.5 years after the product is delivered, whichever is first.*2)
Also, the product may have specified durability, running distance or replacement parts. Please consult your nearest sales branch.
2. For any failure or damage reported within the warranty period which is clearly our responsibility, a replacement product or necessary parts will be provided.
This limited warranty applies only to our product independently, and not to any other damage incurred due to the failure of the product.
3. Prior to using SMC products, please read and understand the warranty terms and disclaimers noted in the specified catalog for the particular products.

*2) Vacuum pads are excluded from this 1 year warranty.

A vacuum pad is a consumable part, so it is warranted for a year after it is delivered.
Also, even within the warranty period, the wear of a product due to the use of the vacuum pad or failure due to the deterioration of rubber material are not covered by the limited warranty.

Compliance Requirements

1. The use of SMC products with production equipment for the manufacture of weapons of mass destruction (WMD) or any other weapon is strictly prohibited.
2. The exports of SMC products or technology from one country to another are governed by the relevant security laws and regulations of the countries involved in the transaction. Prior to the shipment of a SMC product to another country, assure that all local rules governing that export are known and followed.

Caution

SMC products are not intended for use as instruments for legal metrology.

Measurement instruments that SMC manufactures or sells have not been qualified by type approval tests relevant to the metrology (measurement) laws of each country. Therefore, SMC products cannot be used for business or certification ordained by the metrology (measurement) laws of each country.

Safety Instructions

Be sure to read the “Handling Precautions for SMC Products” (M-E03-3) and “Operation Manual” before use.

SMC Corporation

Akihabara UDX 15F,
4-14-1, Sotokanda, Chiyoda-ku, Tokyo 101-0021, JAPAN
Phone: 03-5207-8249 Fax: 03-5298-5362
<https://www.smcworld.com>
© 2022 SMC Corporation All Rights Reserved

Specifications are subject to change without prior notice and any obligation on the part of the manufacturer.

D-G