

# Angle Seat Valve / Air Operated Type

New

RoHS

Low pressure loss due to angle seat structure!



## Long service life

Air Water

**10 million cycles**

Steam

**3 million cycles**

\* Based on SMC's test conditions (for JSB21)

## Large flow rate p. 1

A large flow rate is possible due to the optimized flow channel shape. (Cv factor: approx. 2.5 times)

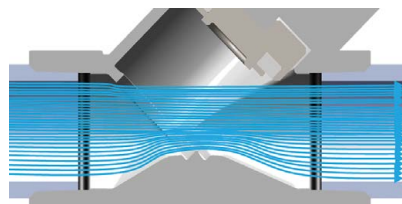

\* Port size: 1" (25A)

## Compact



\* Port size: 1"

## Abundant series variations of 7 sizes

Size	Port size	Cv factor	Body material	Fluid temperature [°C]	
				Water, Air	Steam
1	3/8 (10A)	5.0	Stainless steel 316L equivalent	99 or less	183 or less
2	1/2 (15A)	8.0			
3	3/4 (20A)	16.0			
4	1" (25A)	29.1			
5	1 1/4" (32A)	41.3			
6	1 1/2" (40A)	59.5			
7	2" (50A)	87.5			



**JSB Series**



CAT.ES70-62A

## Low pressure loss, Large flow rate

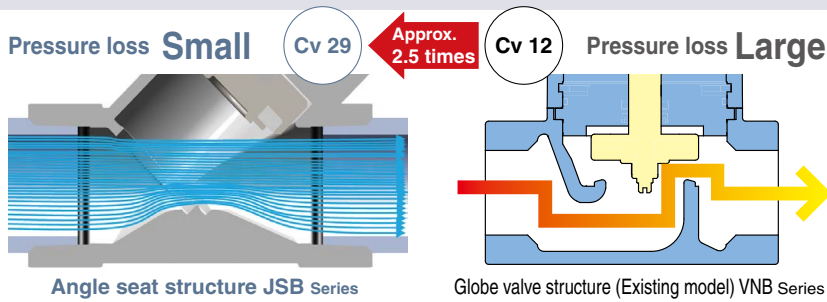

\* Comparison based on port size 1" (25A)

## Low leakage

**Internal leakage**

**10 cm<sup>3</sup>/min** or less<sup>\*1</sup>

\*1 With air

## Long service life

**Air** **Water** **10 million cycles**<sup>\*1</sup>

**Steam** **3 million cycles**<sup>\*1</sup>

\*1 Based on SMC's test conditions (for JSB21)

### Squeeze seal with scraper function

A scraper function has been added to the seal to shut off fluid leakage.

### Resin scraper

Scraper function used during the main valve stroke

### Guide bushing

Prevents misalignment and lengthens the squeeze seal life

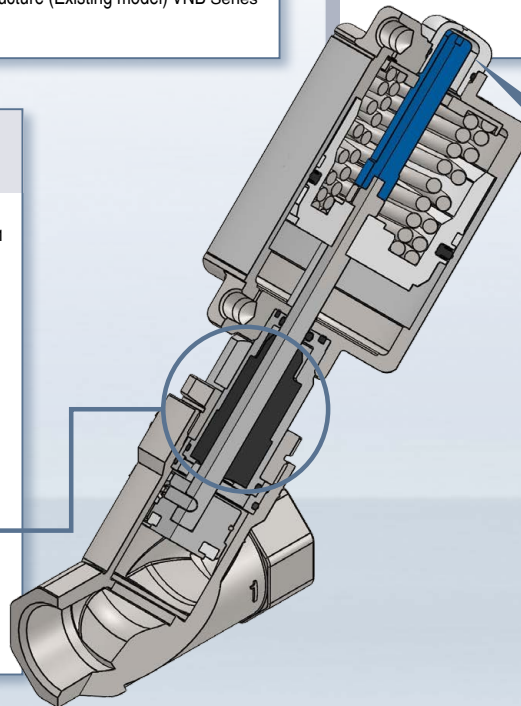

**Indicator (Blue)**

Visual confirmation of valve open/close status

## All-in-One



## Clean design

Smooth head surface  
(Material: Stainless steel 304)

## Options

### Fittings for Pilot Port

- Metal One-touch Fittings **KQB2 Series**
- Stainless Steel 316 One-touch Fittings **KQG2 Series**

### For Breathing Port

- Sintered Metal Element (Stainless Steel) **ESKA Series**
- Metal One-touch Fittings **KQB2 Series**
- Stainless Steel 316 One-touch Fittings **KQG2 Series**

## Easy maintenance

Each part can be replaced.

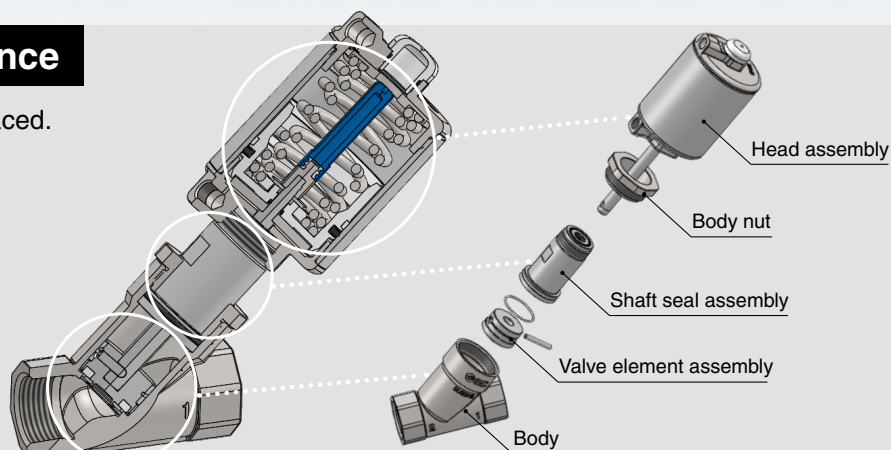

# CONTENTS

## Angle Seat Valve / Air Operated Type JSB Series



How to Order .....	p. 3
Standard Specifications .....	p. 3
Flow Rate Characteristics .....	p. 3
Fluid and Ambient Temperatures .....	p. 4
Valve Leakage Rate .....	p. 4
Construction .....	p. 4
Dimensions .....	p. 5
Options .....	p. 7
Flow Rate Characteristics .....	p. 8
Flow Rate Characteristics (Graph) .....	p. 13
Specific Product Precautions .....	p. 15

# Angle Seat Valve / Air Operated Type

# JSB Series



RoHS



## How to Order

JSB **4** **1** - **ST** **25A** **R** - **4** **S**

① ② ③ ④ ⑤ ⑥ ⑦ ⑧

### ① Valve size

Symbol	Series
1	10
2	20
3	30
4	40
5	50
6	60
7	70

### ② Valve type

Symbol	Valve type
1	N.C.

### ④ Seal material

Symbol	Material
T	Fluororesin

### ⑤ Port size

Symbol	Port size	① Valve size						
		1	2	3	4	5	6	7
10A	3/8	●						
15A	1/2		●					
20A	3/4			●				
25A	1				●			
32A	1 1/4					●		
40A	1 1/2						●	
50A	2							●

### ③ Body material

Symbol	Material
S	Stainless steel

### ⑥ Thread type

Symbol	Thread type
R	Rc
N	NPT
F	G

\* The pilot and breathing ports have the same thread type as the main port.

### ⑦ Head size

Symbol	Bore size	① Valve size						
		1	2	3	4	5	6	7
2	ø40	●	●					
3	ø50			●				
4	ø63				●			
5	ø80					●		
6	ø100						●	
7	ø125							●

### ⑧ Head material

Symbol	Material
S	Stainless steel

## Standard Specifications

Valve specifications	Valve construction	Air operated piston type
	Withstand pressure	2.4 MPa
	Body material	Stainless steel 316L equivalent
	Seal material	Fluororesin
	Environment	Location without corrosive or explosive gases

## Flow Rate Characteristics **N.C.** (Normally closed)

Valve size	Port size	Flow rate characteristics*1		Max. operating pressure [MPa]	Pilot pressure [MPa]	Model	Weight [g]
		Kv	Cv				
1	3/8 (10A)	4.3	5.0	1.0	0.5 to 1.0	JSB11-ST10A□-2S	780
2	1/2 (15A)	6.9	8.0	1.0	0.5 to 1.0	JSB21-ST15A□-2S	850
3	3/4 (20A)	13.8	16.0	1.0	0.5 to 1.0	JSB31-ST20A□-3S	1350
4	1" (25A)	25.2	29.1	1.0	0.5 to 1.0	JSB41-ST25A□-4S	2100
5	1 1/4" (32A)	35.7	41.3	1.0	0.5 to 1.0	JSB51-ST32A□-5S	3700
6	1 1/2" (40A)	51.5	59.5	1.0	0.5 to 1.0	JSB61-ST40A□-6S	5400
7	2" (50A)	75.7	87.5	1.0	0.5 to 1.0	JSB71-ST50A□-7S	8700

\*1 The values are based on SMC's measurement conditions (JIS B 2005-1:2012).

\* When using steam as fluid, see page 7 for selecting the pilot piping option.

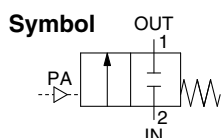

## Fluid and Ambient Temperatures

Fluid temperature [°C]	Ambient temperature [°C]
Steam: 183 or less Water, Air: 99 or less	0 to 60

\* No freezing

## Valve Leakage Rate

### Internal Leakage

Fluid	Seal material	Leakage rate*1
Steam, Air	Fluororesin	10 cm <sup>3</sup> /min or less*2
Water		1 cm <sup>3</sup> /min or less

### External Leakage

Fluid	Seal material	Leakage rate*1
Steam, Air	Fluororesin	10 cm <sup>3</sup> /min or less*2
Water		1 cm <sup>3</sup> /min or less

\*1 Leakage is the value at an ambient temperature of 20°C.

\*2 With air

## Construction

### Component Parts

No.	Description	Material
1	Pilot head assembly	Stainless steel 304 equivalent, Iron, Resin, FKM
2	Shaft seal holder assembly	Stainless steel 316L, Fluororesin, PEEK, FKM, Resin
3	Body nut	Stainless steel 304 equivalent
4	Rod	Stainless steel 316L
5	Valve element assembly	Stainless steel 316L, Fluororesin
6	Body	Stainless steel 316L equivalent

\* Materials of parts in contact with fluid: Stainless steel 316L equivalent, Fluororesin, PEEK, FKM

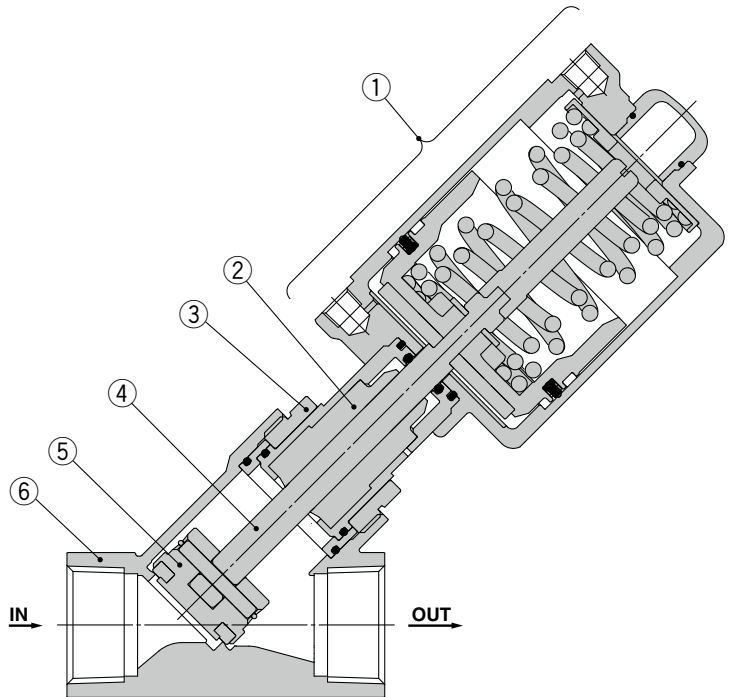



# JSB Series

## Dimensions

### JSB11, 21

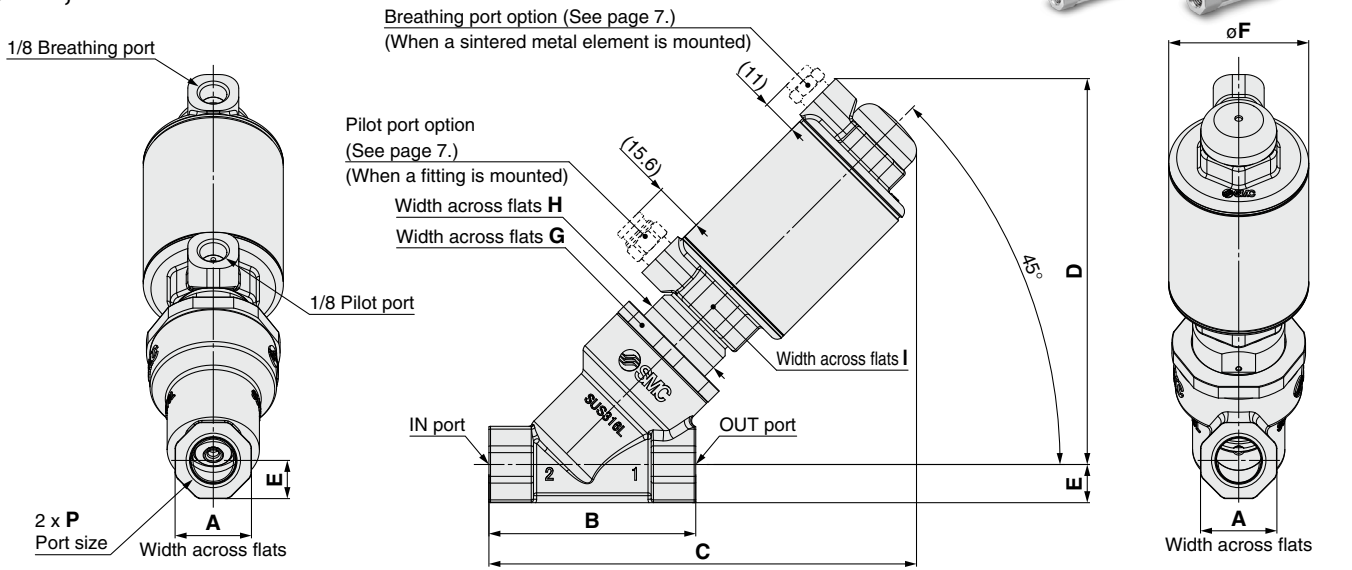

### Dimensions

Model	Port size P	A	B	C	D	E	F	G	H	I
JSB11	3/8	24	65	134.4	121.3	12	44	40	27	27
JSB21	1/2	29	65	134.9	122.3	14.5	44	40	27	27

### JSB31, 41

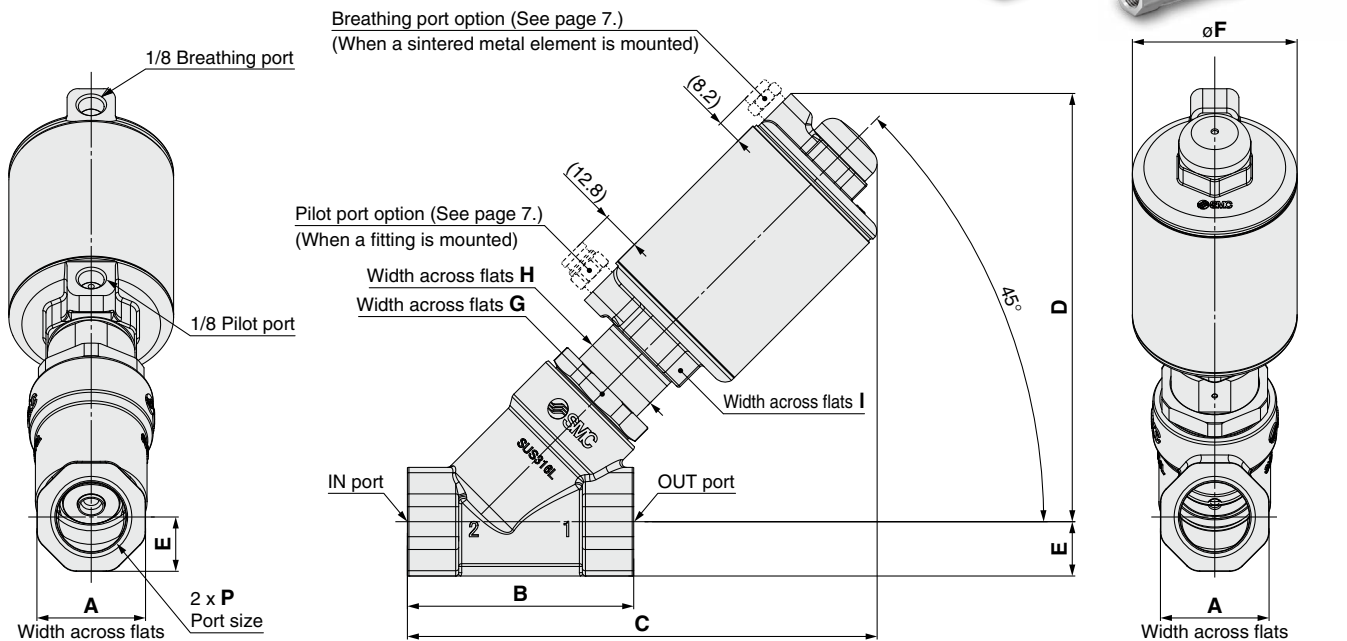

### Dimensions

Model	Port size P	A	B	C	D	E	F	G	H	I
JSB31	3/4	36	75	155.7	141.9	18	54.6	35	27	30
JSB41	1	41	90	188	166	20.5	68	46	29	36

# Angle Seat Valve / Air Operated Type **JSB Series**

## Dimensions

JSB51, 61, 71

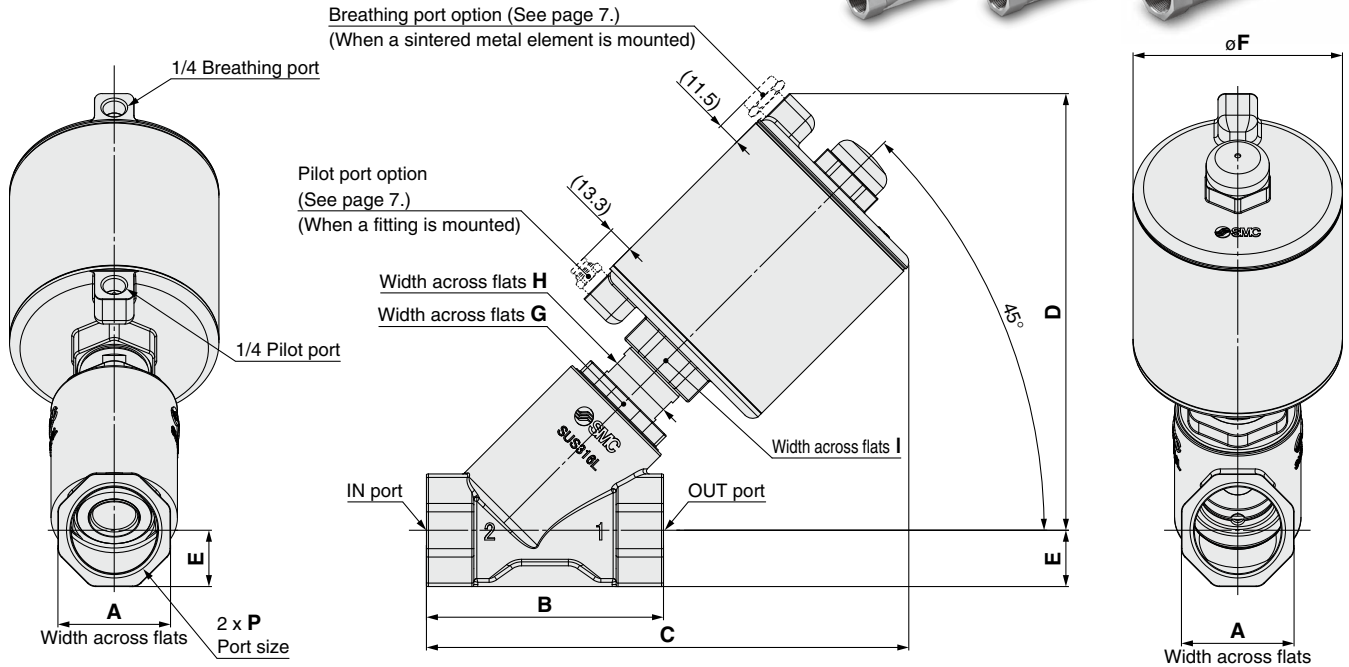

## Dimensions

[mm]

Model	Port size P	A	B	C	D	E	F	G	H	I
JSB51	1 1/4	51	110	222.9	200.5	25.5	86	41	33	41
JSB61	1 1/2	57	120	244.2	221	28.5	106	50	33	41
JSB71	2	70	150	277.7	242.4	35	131	55	33	41

# JSB Series Options

**Caution** Recommended tube fittings when using steam as fluid

## For Pilot Port

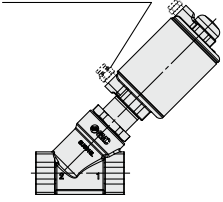
Mounting position	Description	Applicable tubing O.D.	Head size: 1 to 4 (1/8 thread)			Head size: 5 to 7 (1/4 thread)		
			Rc	NPT	G	Rc	NPT	G
 <p>* Mounted by the customer</p>	Metal One-touch fittings KQB2 series (Brass, Electroless nickel plating)	ø6 (Millimeter size)	KQB2H06-01S	—	KQB2H06-G01	KQB2H06-02S	—	KQB2H06-G02
		1/4" (Inch size)	—	KQB2H07-N01S	—	—	KQB2H07-N02S	—
	Stainless steel 316 One-touch fittings KQG2 series	ø6 (Millimeter size)	KQG2H06-01S	—	KQG2H06-G01-F	KQG2H06-02S	—	KQG2H06-G02-F
		1/4" (Inch size)	—	KQG2H07-N01S	—	—	KQG2H07-N02S	—

## For Breathing Port

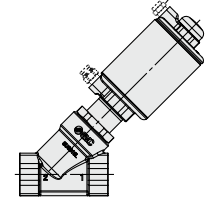
Mounting position	Description	Applicable tubing O.D.	Head size: 1 to 4 (1/8 thread)			Head size: 5 to 7 (1/4 thread)		
			Rc	NPT	G	Rc	NPT	G
 <p>* Mounted by the customer</p>	Sintered metal element (Stainless steel)	—	ESKA-Z2811-120	ESKA-Z2811N-120	ESKA-Z2811F-120	ESKA-Z2812-120	ESKA-Z2812N-120	ESKA-Z2812F-120
	Metal One-touch fittings KQB2 series (Brass, Electroless nickel plating)	ø6 (Millimeter size)	KQB2H06-01S	—	KQB2H06-G01	KQB2H06-02S	—	KQB2H06-G02
		1/4" (Inch size)	—	KQB2H07-N01S	—	—	KQB2H07-N02S	—
	Stainless steel 316 One-touch fittings KQG2 series	ø6 (Millimeter size)	KQG2H06-01S	—	KQG2H06-G01-F	KQG2H06-02S	—	KQG2H06-G02-F
1/4" (Inch size)		—	KQG2H07-N01S	—	—	KQG2H07-N02S	—	

## Tightening Torque

Thread size	Thread type	Tightening torque [N·m]	Option part no.
1/8 thread	Rc NPT	3 to 5	KQ(B, G)2H06-01S
			KQ(B, G)2H07-N01S
			ESKA-Z2811(N)-120
	G	2.9 to 3.2	KQB2H06-G01
			KQG2H06-G01-F
			ESKA-Z2811F-120
1/4 thread	Rc NPT	8 to 12	KQ(B, G)2H06-02S
			KQ(B, G)2H07-N02S
			ESKA-Z2812(N)-120
	G	5.7 to 6.3	KQB2H06-G02
			KQG2H06-G02-F
			ESKA-Z2812F-120

\* When using fluids other than steam, select the fitting and tubing according to the operating environment.

\* When using steam as fluid, use of a nylon tube T0604 (millimeter size: Rc, G) or T1A07 (inch size: NPT) is recommended for pilot piping.

**Metal  
One-touch Fittings  
KQB2 Series**



**Stainless Steel 316  
One-touch Fittings  
KQG2 Series**





# Flow Rate Characteristics

## (How to indicate flow rate characteristics)

Scan the QR code to access software for easy flow rate calculation.  
For details ▶



### 1. Indication of flow rate characteristics

The flow rate characteristics of equipment, such as a solenoid valve, etc., are indicated in their specifications as shown in Table (1).

**Table (1) Indication of Flow Rate Characteristics**

Corresponding equipment	Indication by international standard	Other indications	Compliant standards
Pneumatic equipment	<b>C, b</b>	—	ISO 6358:1989 JIS B 8390:2000
	—	<b>S</b>	JIS B 8390:2000 Equipment: JIS B 8379, 8381-1, 8381-2
		<b>Cv</b>	ANSI/(NFPA)T3.21.3 R1-2008
Process fluid control equipment	<b>Kv</b>	—	IEC 60534-1:2005 IEC 60534-2-3:1997 JIS B 2005-1:2012
	—	<b>Cv</b>	JIS B 2005-2-3:2004 Equipment: JIS B 8471, 8472, 8473

### 2. Pneumatic equipment

#### 2.1 Indication according to the international standards

##### (1) Compliant standards

**ISO 6358:1989 : Pneumatic fluid power—Components using compressible fluids—Determination of flow rate characteristics**

**JIS B 8390:2000 : Pneumatic fluid power—Components using compressible fluids—How to test flow rate characteristics**

##### (2) Definition of flow rate characteristics

The flow rate characteristics are indicated as a result of a comparison between the sonic conductance **C** and the critical pressure ratio **b**.

**Sonic conductance C** : Value which divides the passing mass flow rate of a piece of equipment in a choked flow condition by the product of the upstream absolute pressure and the density in a standard condition.

**Critical pressure ratio b** : Pressure ratio (downstream pressure/upstream pressure) which will turn to a choked flow when the value is smaller than this ratio.

**Choked flow** : Flow in which the upstream pressure is higher than the downstream pressure and where sonic speed in a certain part of a piece of equipment is reached.

Gaseous mass flow rate is in proportion to the upstream pressure and not dependent on the downstream pressure.

**Subsonic flow** : Flow greater than the critical pressure ratio.

**Standard condition** : Air in a temperature state of 20°C, absolute pressure 0.1 MPa (= 100 kPa = 1 bar), relative humidity 65%.

It is stipulated by adding the “(ANR)” after the unit depicting air volume. (Standard reference atmosphere)

Compliant standards: ISO 8778:1990 Pneumatic fluid power—Standard reference atmosphere, JIS B 8393:2000: Pneumatic fluid power—Standard reference atmosphere

##### (3) Formula for flow rate

It is described by the practical units as following.

When

$$\frac{P_2 + 0.1}{P_1 + 0.1} \leq b, \text{ choked flow}$$

$$Q = 600 \times C (P_1 + 0.1) \sqrt{\frac{293}{273 + T}} \dots\dots\dots(1)$$

When

$$\frac{P_2 + 0.1}{P_1 + 0.1} > b, \text{ subsonic flow}$$

$$Q = 600 \times C (P_1 + 0.1) \sqrt{1 - \left[ \frac{P_2 + 0.1}{P_1 + 0.1} - b \right]^2} \sqrt{\frac{293}{273 + T}} \dots\dots\dots(2)$$

**Q** : Air flow rate [L/min (ANR)]

**C** : Sonic conductance [ $\text{dm}^3/(\text{s}\cdot\text{bar})$ ],  $\text{dm}^3$  (Cubic decimeter) of SI units = L (liter)

**b** : Critical pressure ratio [—]

**P<sub>1</sub>** : Upstream pressure [MPa]

**P<sub>2</sub>** : Downstream pressure [MPa]

**T** : Temperature [ $^{\circ}\text{C}$ ]

\* Formula of subsonic flow is the elliptic analogous curve.

Flow rate characteristics are shown in Graph (1). For details, please use the calculation software available from the SMC website.

Example)

Obtain the air flow rate for **P<sub>1</sub>** = 0.4 [MPa], **P<sub>2</sub>** = 0.3 [MPa], **T** = 20 [ $^{\circ}\text{C}$ ] when a solenoid valve is performed in **C** = 2 [ $\text{dm}^3/(\text{s}\cdot\text{bar})$ ] and **b** = 0.3.

According to formula 1, the max. flow rate =  $600 \times 2 \times (0.4 + 0.1) \times \sqrt{\frac{293}{273 + 20}} = 600$  [L/min (ANR)]

$$\text{Pressure ratio} = \frac{0.3 + 0.1}{0.4 + 0.1} = 0.8$$

Based on Graph (1), it will be 0.7 if the pressure ratio is 0.8 and the flow rate ratio is **b** = 0.3.  
Hence, the flow rate = Max. flow x flow ratio =  $600 \times 0.7 = 420$  [L/min (ANR)]

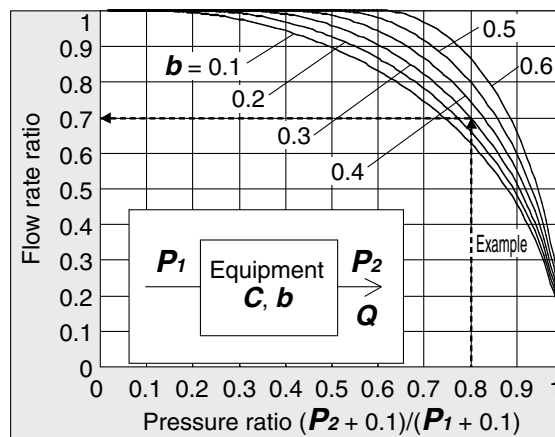

**Graph (1) Flow rate characteristics**

#### (4) Test method

Connect the piece of test equipment to the test circuit as shown in Fig. (1). While maintaining the upstream pressure at a fixed value above 0.3 MPa, measure the max. flow to be saturated initially. Next, measure this flow rate at 80%, 60%, 40%, and 20%, as well as the upstream and downstream pressure. The sonic conductance **C** can be calculated based on this max. flow rate. Use the data of the others and the subsonic flow formula to find **b**, and calculate the critical pressure ratio **b** from that average.

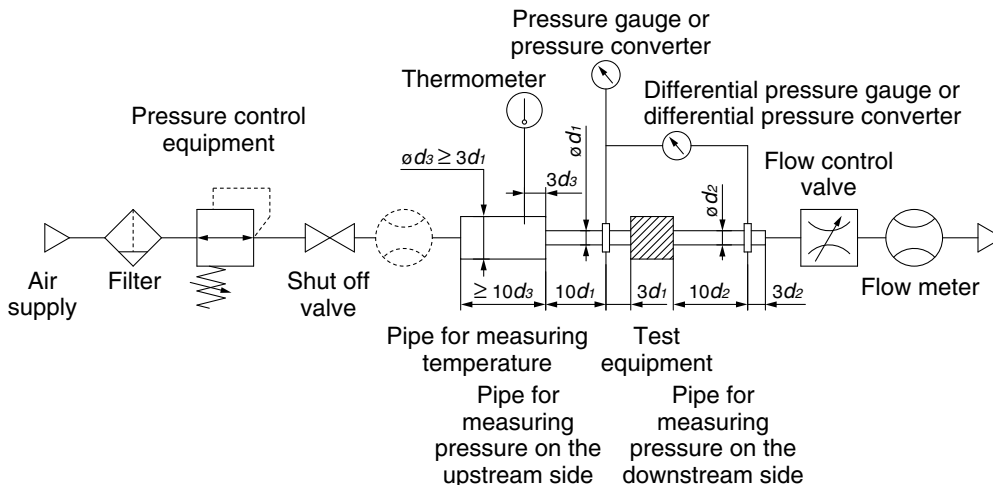

**Fig. (1) Test circuit based on ISO 6358:1989, JIS B 8390:2000**

**2.2 Effective area S**

(1) Compliant standards

**JIS B 8390:2000: Pneumatic fluid power—Components using compressible fluids—**

**How to test flow rate characteristics**

Equipment standards: **JIS B 8373: Solenoid valve for pneumatics**

**JIS B 8379: Silencer for pneumatics**

**JIS B 8381-1: Fittings for pneumatics—Part 1: Push-in fittings for thermoplastic resin tubing**

**JIS B 8381-2: Fittings for pneumatics—Part 2: Compression fittings for thermoplastic resin tubing**

(2) Definition of flow rate characteristics

Effective area **S**: Cross-sectional area that has an ideal throttle without friction or reduced flow. The value is derived by calculating pressure changes inside of an air tank when the compressed air is discharged from a piece of equipment mounted on the tank in a choked flow. The value of the effective area **S**, like that of sonic conductance **C**, expresses the “ease of flow.”

(3) Formula for flow rate

When

$$\frac{P_2 + 0.1}{P_1 + 0.1} \leq 0.5, \text{ choked flow}$$

$$Q = 120 \times S (P_1 + 0.1) \sqrt{\frac{293}{273 + T}} \dots\dots\dots(3)$$

When

$$\frac{P_2 + 0.1}{P_1 + 0.1} > 0.5, \text{ subsonic flow}$$

$$Q = 240 \times S \sqrt{(P_2 + 0.1) (P_1 - P_2)} \sqrt{\frac{293}{273 + T}} \dots\dots\dots(4)$$

Conversion with sonic conductance **C**:

$$S = 5.0 \times C \dots\dots\dots(5)$$

**Q** : Air flow rate [L/min (ANR)]

**S** : Effective area [mm<sup>2</sup>]

**P<sub>1</sub>** : Upstream pressure [MPa]

**P<sub>2</sub>** : Downstream pressure [MPa]

**T** : Temperature [°C]

\* The formula for subsonic flow (4) is only applicable when the critical pressure ratio **b** is the unknown piece of equipment. In the sonic conductance **C** formula (2), it is the same formula as when **b** = 0.5.

(4) Test method

Connect the piece of test equipment to the test circuit as shown in Fig. (2). Discharge the air from the air tank filled with compressed air at a fixed value above 0.6 MPa (0.5 MPa) into the atmosphere until the pressure inside the tank falls to 0.25 MPa (0.2 MPa). Measure the discharge time and the residual pressure inside the tank after discharging until it has returned to the normal value. Then, calculate the effective area **S** using the following formula. Select an air tank with a volume within the specified range of the test equipment’s effective area. For JIS B 8379, the pressure values are in parentheses and the coefficient of the formula is 12.9.

$$S = 12.1 \frac{V}{t} \log_{10} \left( \frac{P_s + 0.1}{P + 0.1} \right) \sqrt{\frac{293}{T}} \dots\dots\dots(6)$$

**S** : Effective area [mm<sup>2</sup>]

**V** : Air tank capacity [L]

**t** : Discharging time [s]

**P<sub>s</sub>**: Pressure inside air tank before discharging [MPa]

**P** : Residual pressure inside air tank after discharging [MPa]

**T** : Temperature inside air tank before discharging [K]

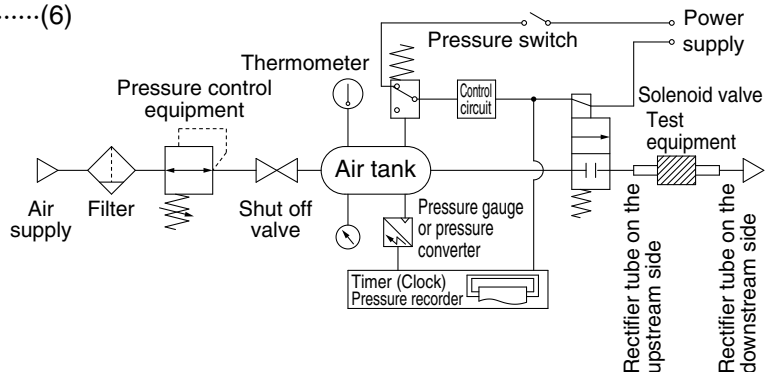

**Fig. (2) Test circuit based on JIS B 8390:2000**

## 2.3 Flow coefficient $C_v$ factor

The United States Standard ANSI/(NFPA)T3.21.3:R1-2008R: Pneumatic fluid power—Flow rating test procedure and reporting method for fixed orifice components

This standard defines the  $C_v$  factor of the flow coefficient by the following formula that is based on the test conducted by the test circuit analogous to ISO 6358.

$$C_v = \frac{Q}{114.5 \sqrt{\frac{\Delta P (P_2 + P_a)}{T_1}}} \dots\dots\dots (7)$$

$\Delta P$  : Pressure drop between the static pressure tapping ports [bar]

$P_1$  : Pressure of the upstream tapping port [bar gauge]

$P_2$  : Pressure of the downstream tapping port [bar gauge]:  $P_2 = P_1 - \Delta P$

$Q$  : Flow rate [L/s standard condition]

$P_a$  : Atmospheric pressure [bar absolute]

$T_1$  : Upstream absolute temperature [K]

The test conditions are  $P_1 + P_a = 6.5 \pm 0.2$  bar absolute,  $T_1 = 297 \pm 5K$ ,  $0.07 \text{ bar} \leq \Delta P \leq 0.14 \text{ bar}$ .

This is the same concept as the effective area  $A$  which ISO 6358 stipulates as being applicable only when the pressure drop is smaller than the upstream pressure and the compression of air does not become a problem.

## 3. Process fluid control equipment

### (1) Compliant standards

**IEC 60534-1:2005: Industrial-process control valves. Part 1: Control valve terminology and general considerations**

**IEC 60534-2-3:1997: Industrial-process control valves. Part 2: Flow capacity, Section Three-Test procedures**

**JIS B 2005-1:2012: Industrial-process control valves – Part 1: Control valve terminology and general considerations**

**JIS B 2005-2-3:2004: Industrial-process control valves – Part 2: Flow capacity – Section 3: Test procedures**

**Equipment standards: JIS B 8471: Solenoid valve for water**

**JIS B 8472: Solenoid valve for steam**

**JIS B 8473: Solenoid valve for fuel oil**

### (2) Definition of flow rate characteristics

**$K_v$  factor:** Value of the clean water flow rate (represented by  $m^3/h$ ) which runs through a valve (test equipment) at 5 to 40°C when the pressure difference is  $1 \times 10^5$  Pa (1 bar). It is calculated using the following formula.

$$K_v = Q \sqrt{\frac{1 \times 10^5}{\Delta P} \cdot \frac{\rho}{1000}} \dots\dots\dots (8)$$

$K_v$  : Flow coefficient [ $m^3/h$ ]

$Q$  : Flow rate [ $m^3/h$ ]

$\Delta P$  : Pressure difference [Pa]

$\rho$  : Density of fluid [ $kg/m^3$ ]

### (3) Formula of flow rate

It is described by practical units. Also, the flow rate characteristics are shown in Graph (2).

In the case of liquids:

$$Q = 53 K_v \sqrt{\frac{\Delta P}{G}} \dots\dots\dots (9)$$

$Q$  : Flow rate [L/min]

$K_v$  : Flow coefficient [ $m^3/h$ ]

$\Delta P$  : Pressure difference [MPa]

$G$  : Relative density [water = 1]

In the case of saturated aqueous vapor:

$$Q = 232 K_v \sqrt{\Delta P (P_2 + 0.1)} \dots\dots\dots (10)$$

$Q$  : Flow rate [kg/h]

$K_v$  : Flow coefficient [ $m^3/h$ ]

$\Delta P$  : Pressure difference [MPa]

$P_1$  : Upstream pressure [MPa]:  $\Delta P = P_1 - P_2$

$P_2$  : Downstream pressure [MPa]

Conversion of flow coefficient:

$$Kv = 0.865 Cv \dots\dots\dots(11)$$

Here,

**Cv** factor: Value of the clean water flow rate (represented by US gal/min) which runs through a valve at 40 to 100°F when the pressure difference is 1 lbf/in<sup>2</sup> (psi)

The values of **Kv** and **Cv** factors for pneumatic purposes are different due to different test methods.

(4) Test method

Connect the piece of test equipment to the test circuit as shown in Fig. (3), and run water at 5 to 40°C. Then, measure the flow rate with a pressure difference where vaporization does not occur in a turbulent flow (pressure difference of 0.035 MPa to 0.075 MPa when the inlet pressure is within 0.15 MPa to 0.6 MPa). However, as the turbulent flow is definitely caused, the pressure difference needs to be set with a large enough difference so that the Reynolds number does not fall below  $1 \times 10^5$ , and the inlet pressure needs to be set slightly higher to prevent vaporization of the liquid. Substitute the measurement results in formula (8) to calculate **Kv**.

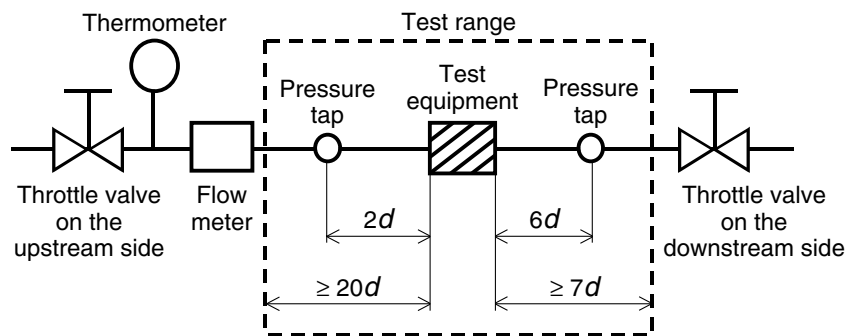
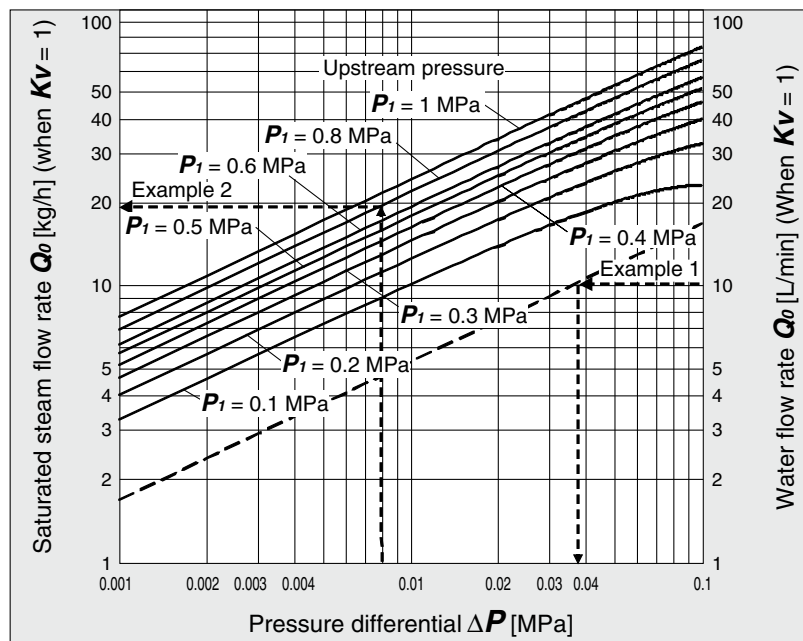

Fig. (3) Test circuit based on IEC 60534-2-3, JIS B 2005-2-3



Graph (2) Flow rate characteristics

Example 1)

Obtain the pressure difference when 15 [L/min] of water runs through a solenoid valve with a **Kv** = 1.5 [m<sup>3</sup>/h]. As the flow rate when **Kv** = 1 is calculated as the formula:  $Q_0 = 15 \times 1/1.5 = 10$  [L/min], read off  $\Delta P$  when  $Q_0$  is 10 [L/min] in Graph (2). The reading is 0.036 [MPa].

Example 2)

Obtain the saturated steam flow rate when  $P_1 = 0.8$  [MPa] and  $\Delta P = 0.008$  [MPa] with a solenoid valve with a **Kv** = 0.05 [m<sup>3</sup>/h]. Read off  $Q_0$  when  $P_1$  is 0.8 and  $\Delta P$  is 0.008 in Graph (2), the reading is 20 [kg/h]. Therefore, the flow rate is calculated as the formula:  $Q = 0.05/1 \times 20 = 1$  [kg/h].

# Flow Rate Characteristics (Graph)

\* Use this graph as a guide. If an accurate flow rate is required, refer to pages 8 to 12.

## For Air

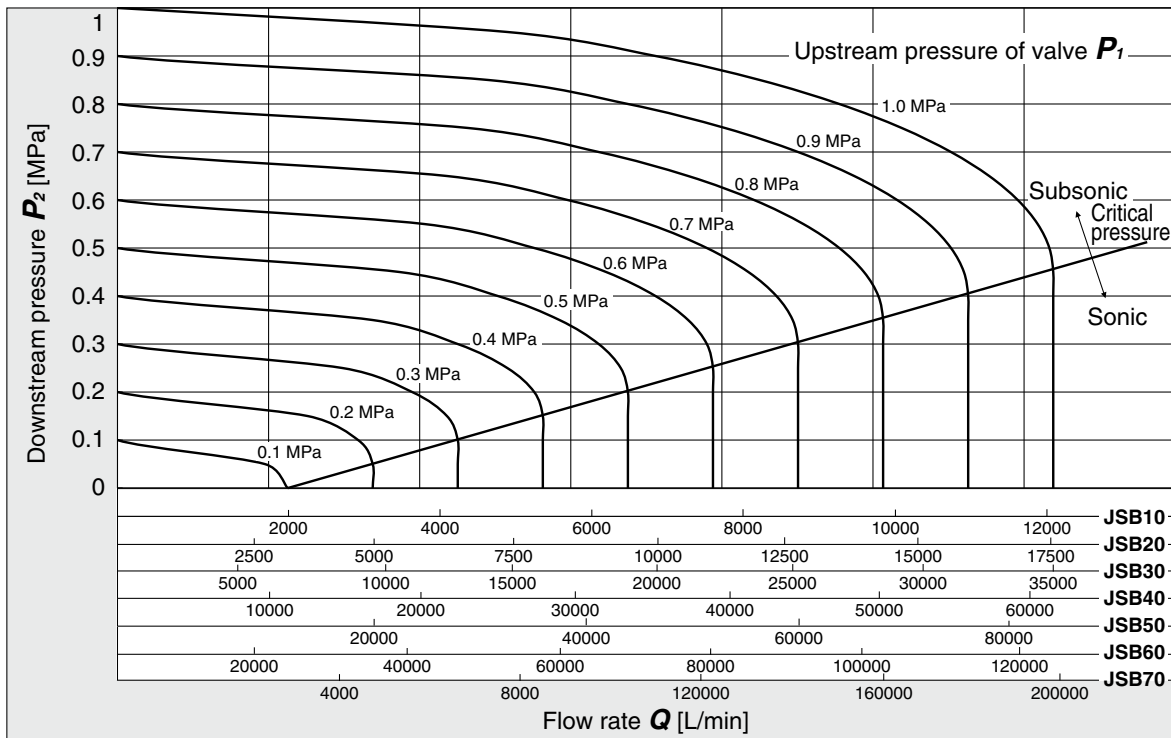

### How to read the graph

The sonic range pressure to generate a flow rate of 6000 L/min (ANR) is  $P_1 \approx 0.3$  MPa for the JSB20.

## For Water

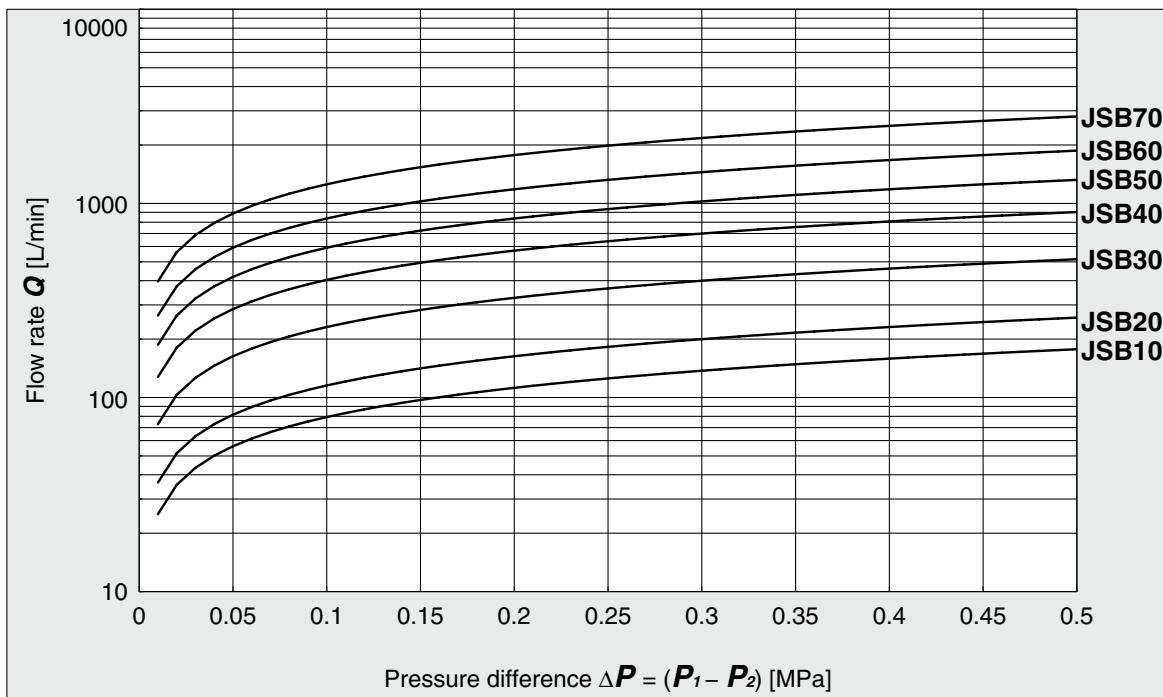

### How to read the graph

When a water flow of 500 L/min is generated,  $\Delta P \approx 0.15$  MPa for the JSB40.



## For Saturated Steam

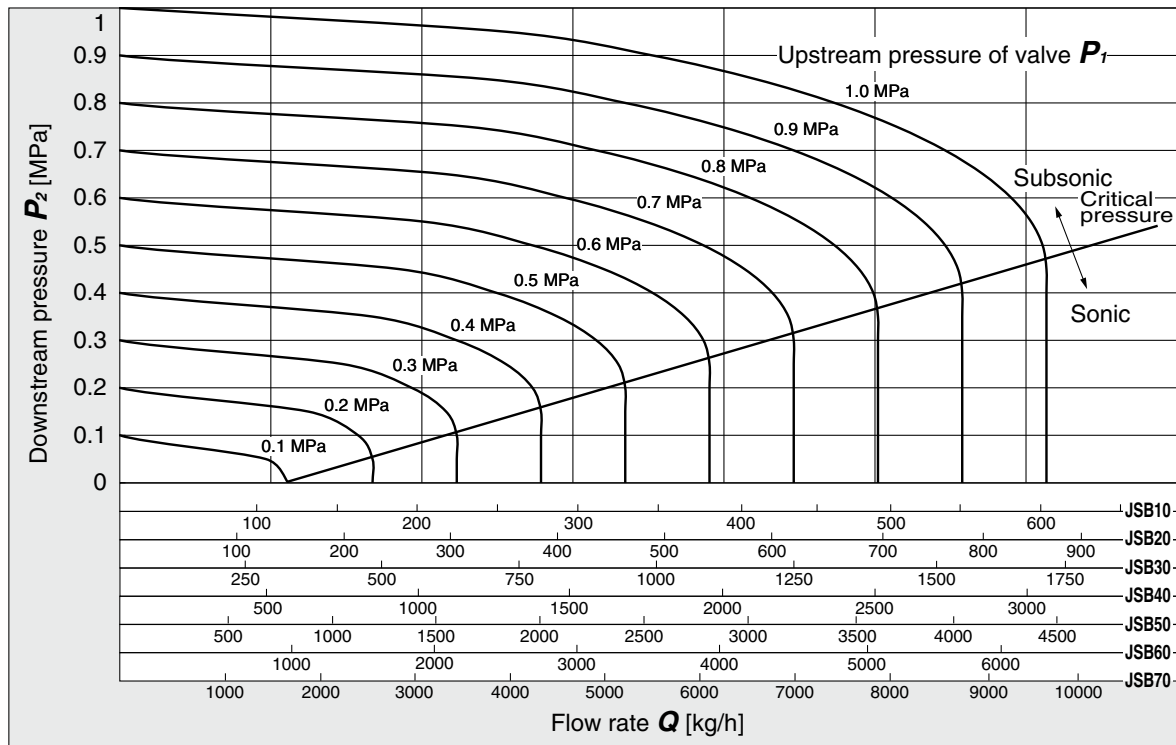

### How to read the graph

The sonic range pressure to generate a flow rate of 300 kg/h is  $P_1 \approx 0.3$  MPa for the JSB20.



## JSB Series

# Specific Product Precautions 1

Be sure to read this before handling the products. Refer to the back cover for safety instructions. For 2-port solenoid valve for fluid control precautions, refer to the “Handling Precautions for SMC Products” and the “Operation Manual” on the SMC website: <https://www.smcworld.com>

### Design

#### Warning

1. For usage of reverse pressure, please contact SMC.
2. Cannot be used as an emergency shutoff valve, etc.

The valves presented in this catalog are not designed for safety applications such as an emergency shutoff valve. If the valves are used in this type of system, other reliable safety assurance measures should also be adopted.

3. Closed liquid circuit

In a closed circuit, when liquid is static, pressure could rise due to changes in temperature. This pressure rise could cause malfunction and damage to components such as valves. To prevent this, install a relief valve in the system.

4. Pressure holding

It cannot be used for an application such as holding the pressure inside of a pressure vessel because air leakage is entailed in a valve.

5. When an impact, such as steam hammer, etc., caused by rapid pressure fluctuation is applied, the valve may be damaged. Please use with caution.

### Selection

#### Warning

1. Fluid

Corrosive gases cannot be used since cracks caused by stress corrosion or other incidents may result.

2. Air quality

<Steam, Water>

The use of a fluid that contains foreign matter can cause problems, such as malfunction and seal failure, by promoting the wear of the valve seat and seal. Install a suitable filter (strainer) immediately upstream from the valve. As per standard, the mesh count for the strainer should be 100 mesh. However, the size and shape of the foreign matter that occur depends on the operating environment. Check the fluid status and choose an appropriate mesh count.

The supply water to a boiler includes materials that create a hard sediment or sludge, such as calcium and magnesium.

Sediment and sludge from steam can cause the valve to not operate properly. Install a water softening device which removes these materials. Do not use operation steam which contains chemicals, synthetic oils that contain organic solvents, salts, corrosive gases, etc., as these can cause damage or deterioration.

The seal material (special FKM) used for wetted parts of the product can withstand steam in standard conditions. However, the resistance of the sealing material can deteriorate depending on the types of additives such as boiler compounds and water conditioners within the boiler steam. Please only utilize the product after determining the sealing material resistance within the actual usage conditions.

### Selection

#### Warning

<Air>

- Use clean air.

Do not use compressed air which contains chemicals, synthetic oils that contain organic solvents, salts, corrosive gases, etc., as these can cause damage or malfunction.

- Install an air filter.

Install air filters close to the valves on the upstream side. A filtration size of 5 μm or less should be selected.

- Install an aftercooler, air dryer, etc.

Compressed air that contains excessive drainage may cause the malfunction of valves and other pneumatic equipment. To prevent this, install an aftercooler, air dryer, etc.

- If excessive carbon powder is generated, eliminate it by installing mist separators on the upstream side of valves.

If excessive carbon powder is generated by the compressor, it may adhere to the inside of the valves and cause a malfunction.

Refer to the **Web Catalog** for further details on compressed air quality.

3. Ambient environment

Use within the operable ambient temperature range. Check the compatibility between the product's composition materials and the ambient atmosphere. Be certain that the fluid used does not touch the external surface of the product.

4. Low-temperature operation

- 1) The valve can be used in an ambient temperature of 0°C. However, take measures to prevent the freezing or solidification of impurities, etc.
- 2) When using valves for water applications in cold climates, take appropriate countermeasures to prevent the water from freezing in the tubing after cutting the water supply from the pump, by draining the water, etc. The installation of a dryer and heat retaining of the body is recommended to prevent a freezing condition in which the dew point temperature is high and the ambient temperature is low, and the high flow runs.



# JSB Series

## Specific Product Precautions 2

Be sure to read this before handling the products. Refer to the back cover for safety instructions. For 2-port solenoid valve for fluid control precautions, refer to the "Handling Precautions for SMC Products" and the "Operation Manual" on the SMC website: <https://www.smcworld.com>

### Mounting

#### Warning

1. If air leakage increases or equipment does not operate properly, stop operation.

After mounting is completed, confirm that it has been done correctly by performing a suitable function test.

2. Do not apply external force to the operating section.

When tightening is performed, apply a wrench or other tool to the outside of the piping connection parts.

3. Mount a valve with its operating section upward, not downward.

If the operating section is installed downward, foreign matter in the fluid may stick to the seal, causing a malfunction.

4. Avoid sources of vibration, or adjust the arm from the body to the minimum length so that resonance will not occur.

5. Painting and coating

Warnings or specifications printed or labeled on the product should not be erased, removed, or covered up.

### Piping

#### Caution

1. Preparation before piping

Before piping is connected, it should be thoroughly blown out with air (flushing) or washed to remove chips, cutting oil, and other debris from inside the pipe. Avoid pulling, compressing, or bending the valve body when piping.

2. Avoid connecting ground lines to piping, as this may cause electric corrosion of the system.

3. Always tighten threads with the proper tightening torque.

Refer to the tightening torque in the table below for connecting steel piping. Insufficient tightening torque will lead to fluid leakage. For mounting the fittings, refer to the specified torque.

#### Tightening Torque for Piping

Connection thread	Proper tightening torque [N·m]	Connection thread	Proper tightening torque [N·m]
Rc3/8	22 to 24	Rc1 1/4	40 to 42
Rc1/2	28 to 30	Rc1 1/2	48 to 50
Rc3/4			
Rc1	36 to 38		

4. When connecting piping to a product, avoid mistakes regarding the connecting direction of the product.

5. Winding of sealant tape

When connecting pipes, fittings, etc., be sure that chips from the pipe threads and sealing material do not enter the valve.

Furthermore, when sealant tape is used, leave 1.5 to 2 thread ridges exposed at the end of the threads.

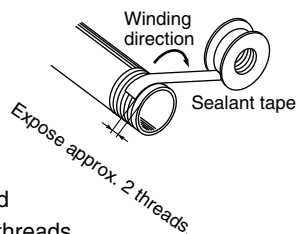

### Piping

#### Caution

6. If an excessive amount of thread sealant, such as sealant tape or liquid thread sealant, is used during piping, it will get inside the product and lead to a malfunction.

7. Steam generated in a boiler contains a large amount of drainage. Be sure to operate it with a drain trap installed.

8. Arrange piping so that condensate will not accumulate in the valve.

Install the piping to the valve higher than the peripheral piping. Be sure to avoid installing the piping to the valve at the lowest part of the piping layout. If condensate accumulates in the valve or peripheral piping, the steam entering the piping will cause steam hammer. This will lead to the destruction and malfunction of the valve and piping. If steam hammer causes problems, install bypass piping to thoroughly discharge condensate from the piping. Apply steam to the device afterward to start operation.

9. For the convenience of maintenance and repair, install a bypass circuit and use a union for piping.

10. To control the fluid in the tank, connect the piping slightly higher than the bottom of the tank.

11. Pilot piping

When using steam as fluid, use the following fittings and tubing:

- Metal One-touch fittings  
KQB2 series, KQG2 series
- Insert fittings  
KF series (Brass sleeve)
- Nylon tubing  
T0604 (ø6), TIA07 (1/4")

When using other fluids, select the fitting and tubing according to the operating environment.

\* Pilot port option

Pilot port option mounting position

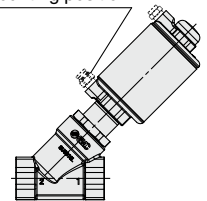

\* Mounted by the customer

12. Breathing port

The breathing port has a small orifice hole.

When there is a risk of dust and foreign matter entering inside the pilot head, consider mounting a sintered metal element or provide tube piping (up to a clean location) to prevent intrusion of foreign matter.

\* Breathing port option  
Breathing port option mounting position

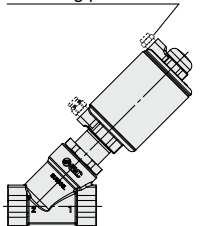

\* Mounted by the customer



# JSB Series

## Specific Product Precautions 3

Be sure to read this before handling the products. Refer to the back cover for safety instructions. For 2-port solenoid valve for fluid control precautions, refer to the “Handling Precautions for SMC Products” and the “Operation Manual” on the SMC website: <https://www.smcworld.com>

### Maintenance

#### Warning

##### 1. Removing the product

The valve will reach a high temperature when used with high-temperature fluids. Confirm that the valve temperature has dropped sufficiently before performing work. If touched inadvertently, there is a danger of being burned.

- 1) Shut off the fluid supply and release the fluid pressure in the system.
- 2) Shut off the power supply.
- 3) Dismount the product.

##### 2. Low-frequency operation

Switch valves at least once every 30 days to prevent a malfunction. Also, in order to use them under the optimum state, conduct a regular inspection biannually.

##### 3. Disassembly

The pilot head assembly cannot be disassembled. It may lead to a serious accident when it is forcefully disassembled.

#### Caution

##### 1. Strainers

- 1) Be careful regarding the clogging of strainers.
- 2) Clean strainers when the pressure drop reaches 0.1 MPa.

##### 2. Lubrication

When using after lubricating, be sure to lubricate continuously.

##### 3. Storage

In case of long term storage after use, thoroughly remove all moisture to prevent rust and the deterioration of rubber materials, etc.

##### 4. Exhaust the drainage from the piping periodically.

### Operating Precautions

#### Warning

1. The valve will reach a high temperature when used with high-temperature fluids. Use caution, as there is a danger of being burned if a valve is touched directly.
2. When problems are caused by steam hammer, install a steam hammer relief device, such as an accumulator.
3. When the valve is closed and pressure exceeding the maximum operating pressure is applied suddenly, due to the starting of a fluid supply source such as a boiler, the valve may open momentarily and fluid may leak.

### Replacement Parts

#### Warning

Contact your SMC representative when replacement parts are necessary for maintenance.

### How to Change the Pilot Port Direction

#### Warning

- 1) Hold the body and the body nut and loosen the body nut.
  - 2) Turn the pilot head and move the pilot port in the desired direction.
  - 3) Hold the body and the body nut and tighten the body nut to the recommended tightening torque described below.
- \* When holding the pilot head side, hold the width across flats of the shaft seal holder assembly using a wrench.

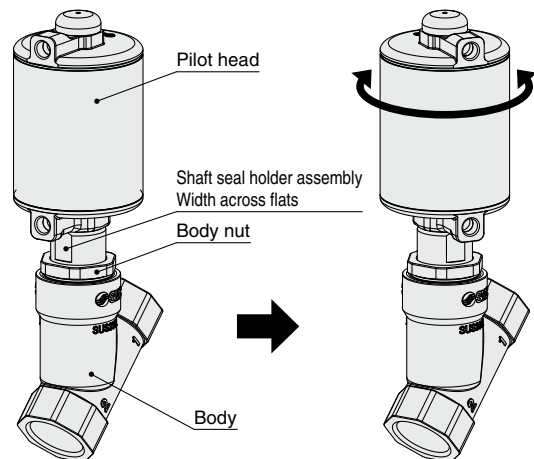



#### Body Nut Tightening Torque

Valve size	Recommended tightening torque [N·m]
JSB10	24 to 26
JSB20	
JSB30	
JSB40	33 to 37
JSB50	
JSB60	
JSB70	

## Safety Instructions

These safety instructions are intended to prevent hazardous situations and/or equipment damage. These instructions indicate the level of potential hazard with the labels of “**Caution**,” “**Warning**” or “**Danger**.” They are all important notes for safety and must be followed in addition to International Standards (ISO/IEC)\*1), and other safety regulations.

 **Caution:** **Caution** indicates a hazard with a low level of risk which, if not avoided, could result in minor or moderate injury.

 **Warning:** **Warning** indicates a hazard with a medium level of risk which, if not avoided, could result in death or serious injury.

 **Danger :** **Danger** indicates a hazard with a high level of risk which, if not avoided, will result in death or serious injury.

\*1) ISO 4414: Pneumatic fluid power – General rules relating to systems.  
ISO 4413: Hydraulic fluid power – General rules relating to systems.  
IEC 60204-1: Safety of machinery – Electrical equipment of machines.  
(Part 1: General requirements)  
ISO 10218-1: Manipulating industrial robots – Safety.  
etc.

### Warning

#### 1. The compatibility of the product is the responsibility of the person who designs the equipment or decides its specifications.

Since the product specified here is used under various operating conditions, its compatibility with specific equipment must be decided by the person who designs the equipment or decides its specifications based on necessary analysis and test results. The expected performance and safety assurance of the equipment will be the responsibility of the person who has determined its compatibility with the product. This person should also continuously review all specifications of the product referring to its latest catalog information, with a view to giving due consideration to any possibility of equipment failure when configuring the equipment.

#### 2. Only personnel with appropriate training should operate machinery and equipment.

The product specified here may become unsafe if handled incorrectly. The assembly, operation and maintenance of machines or equipment including our products must be performed by an operator who is appropriately trained and experienced.

#### 3. Do not service or attempt to remove product and machinery/equipment until safety is confirmed.

1. The inspection and maintenance of machinery/equipment should only be performed after measures to prevent falling or runaway of the driven objects have been confirmed.
2. When the product is to be removed, confirm that the safety measures as mentioned above are implemented and the power from any appropriate source is cut, and read and understand the specific product precautions of all relevant products carefully.
3. Before machinery/equipment is restarted, take measures to prevent unexpected operation and malfunction.

#### 4. Contact SMC beforehand and take special consideration of safety measures if the product is to be used in any of the following conditions.

1. Conditions and environments outside of the given specifications, or use outdoors or in a place exposed to direct sunlight.
2. Installation on equipment in conjunction with atomic energy, railways, air navigation, space, shipping, vehicles, military, medical treatment, combustion and recreation, or equipment in contact with food and beverages, emergency stop circuits, clutch and brake circuits in press applications, safety equipment or other applications unsuitable for the standard specifications described in the product catalog.
3. An application which could have negative effects on people, property, or animals requiring special safety analysis.
4. Use in an interlock circuit, which requires the provision of double interlock for possible failure by using a mechanical protective function, and periodical checks to confirm proper operation.

### Caution

#### 1. The product is provided for use in manufacturing industries.

The product herein described is basically provided for peaceful use in manufacturing industries.  
If considering using the product in other industries, consult SMC beforehand and exchange specifications or a contract if necessary.  
If anything is unclear, contact your nearest sales branch.

### Limited warranty and Disclaimer/ Compliance Requirements

The product used is subject to the following “Limited warranty and Disclaimer” and “Compliance Requirements”.

Read and accept them before using the product.

#### Limited warranty and Disclaimer

1. The warranty period of the product is 1 year in service or 1.5 years after the product is delivered, whichever is first.\*2)  
Also, the product may have specified durability, running distance or replacement parts. Please consult your nearest sales branch.
2. For any failure or damage reported within the warranty period which is clearly our responsibility, a replacement product or necessary parts will be provided.  
This limited warranty applies only to our product independently, and not to any other damage incurred due to the failure of the product.
3. Prior to using SMC products, please read and understand the warranty terms and disclaimers noted in the specified catalog for the particular products.

##### \*2) Vacuum pads are excluded from this 1 year warranty.

A vacuum pad is a consumable part, so it is warranted for a year after it is delivered.  
Also, even within the warranty period, the wear of a product due to the use of the vacuum pad or failure due to the deterioration of rubber material are not covered by the limited warranty.

#### Compliance Requirements

1. The use of SMC products with production equipment for the manufacture of weapons of mass destruction (WMD) or any other weapon is strictly prohibited.
2. The exports of SMC products or technology from one country to another are governed by the relevant security laws and regulations of the countries involved in the transaction. Prior to the shipment of a SMC product to another country, assure that all local rules governing that export are known and followed.

### Caution

#### SMC products are not intended for use as instruments for legal metrology.

Measurement instruments that SMC manufactures or sells have not been qualified by type approval tests relevant to the metrology (measurement) laws of each country. Therefore, SMC products cannot be used for business or certification ordained by the metrology (measurement) laws of each country.

 **Safety Instructions** Be sure to read the “Handling Precautions for SMC Products” (M-E03-3) and “Operation Manual” before use.

## SMC Corporation

Akihabara UDX 15F,  
4-14-1, Sotokanda, Chiyoda-ku, Tokyo 101-0021, JAPAN  
Phone: 03-5207-8249 Fax: 03-5298-5362  
<https://www.smcworld.com>  
© 2023 SMC Corporation All Rights Reserved

Specifications are subject to change without prior notice  
and any obligation on the part of the manufacturer.

D-G