



# Flat Pad

Pad diameter  $\varnothing 10, \varnothing 15, \varnothing 20, \varnothing 25, \varnothing 30$

Symbol/Form

MT: Thin flat type (With groove)

■ Adsorption surface with groove

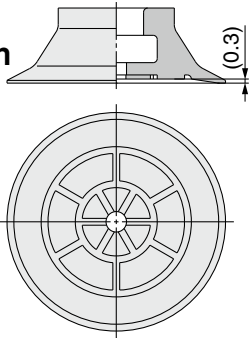

■ For the adsorption of thin sheets or film  
Reduced deformation of flat surfaces during adsorption

- \* Not suitable for transferring workpieces which apply a load.
- \* Wrinkling may be generated depending on the sheet thickness. Confirm the thickness before use.

■ Supports blast type\*<sup>1</sup> pads

- \*<sup>1</sup> Allows for the easy removal of workpieces

## How to Order

Pad unit **ZP2 - B10 MT N**

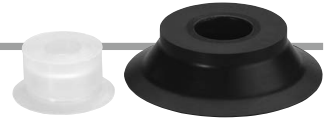

Pad diameter

Symbol	Pad diameter
B10	$\varnothing 10$
B15	$\varnothing 15$
B20	$\varnothing 20$
B25	$\varnothing 25$
B30	$\varnothing 30$

Pad material

Symbol	Material
N	NBR
S	Silicone rubber* <sup>1</sup> , * <sup>2</sup>
F	FKM
GN	Conductive NBR
GS	Conductive silicone rubber

\*<sup>1</sup> Compliant with the FDA (USA Food and Drug Administration) regulation 21CFR§177.2600 for "Rubber articles intended for repeated use"

\*<sup>2</sup> Compliant with the standards for "Rubber apparatus (excluding baby drinking apparatus) and containers/packaging" (D3) (Partial revision: Ministry of Health, Labour, and Welfare Notification No. 595, 2012) in Section 3 "Apparatus and Containers/Packaging" of the Food Sanitation Act, Article 18 "Specifications and Standards for Food and Food Additives, etc." (Ministry of Health and Welfare Notification No. 370, 1959).

Pad form

Symbol	Form
MT	Thin flat type (With groove)

Mounting Bracket Part Nos.

Adapter Assembly p. 288

## Dimensions: Pad Unit

ZP2-B10MT □

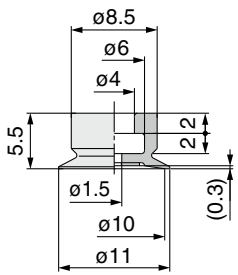

ZP2-B15MT □

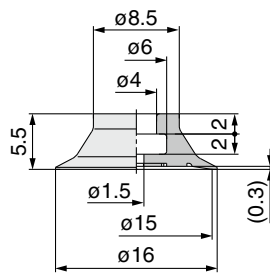

ZP2-B20MT □

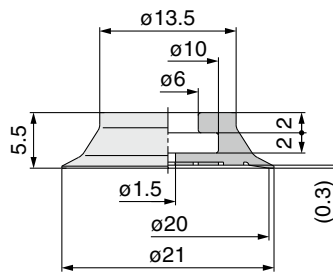

ZP2-B25MT □

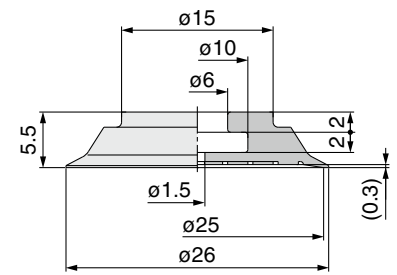

ZP2-B30MT □

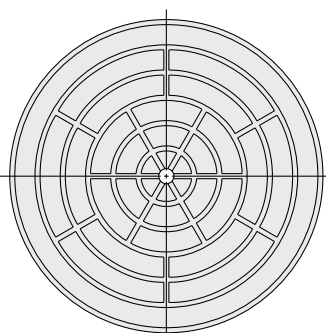
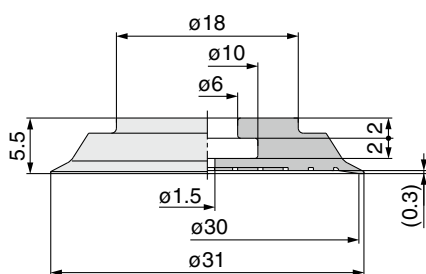

## Adapter Mounting Dimensions

If an adapter will be made by the customer, design the adapter with the dimensions shown below.

Applicable pad B10MT/B15MT

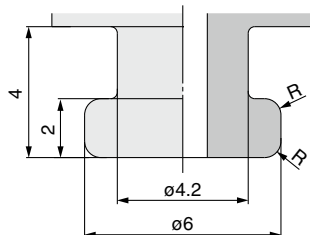

Applicable pad B20MT/B25MT/B30MT

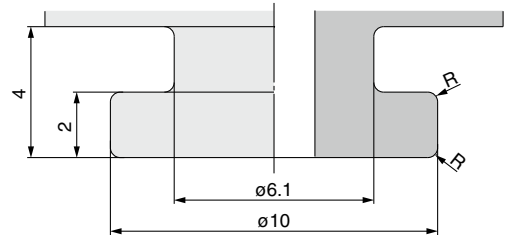

\* The R part has to be smooth with no corners.

Model Selection

For Special Applications

Mark-free

For Film Adsorption

Multistage

Flat

Nozzle

Sponge

For Disk Adsorption

For Panel Holding

Ball Spine Buffer

Construction

Mounting Bracket Assembly

Precautions

# Flat Pad **ZP2 Series**

## How to Order



With adapter **ZP2 - T B10 MT N - H5**

Vacuum inlet direction

Symbol	Direction
T	Vertical

Pad diameter

Symbol	Pad diameter
B10	ø10
B15	ø15
B20	ø20
B25	ø25
B30	ø30

Pad form

Symbol	Form
MT	Thin flat type (With groove)

Gasket\*3

Symbol	Gasket
Nil	Without gasket
G	With gasket

\*3 Connection thread: Only for option "H5" can either "Without gasket" or "With gasket" be selected. When "Nil" is selected for option "A5," it comes with a gasket.

Connection thread

Symbol	Thread size	Adapter type
A5	M5 x 0.8 (Male thread)	Hexagon O.D.
H5	M5 x 0.8 (Male thread)	Hexagon socket head
B5	M5 x 0.8 (Female thread)	Hexagon O.D.

Pad material

Symbol	Material
N	NBR
S	Silicone rubber*1, *2
F	FKM
GN	Conductive NBR
GS	Conductive silicone rubber

\*1 Compliant with the FDA (USA Food and Drug Administration) regulation 21CFR§177.2600 for "Rubber articles intended for repeated use"  
 \*2 Compliant with the standards for "Rubber apparatus (excluding baby drinking apparatus) and containers/packaging" (D3) (Partial revision: Ministry of Health, Labour, and Welfare Notification No. 595, 2012) in Section 3 "Apparatus and Containers/Packaging" of the Food Sanitation Act, Article 18 "Specifications and Standards for Food and Food Additives, etc." (Ministry of Health and Welfare Notification No. 370, 1959).

\* If used without a gasket, vacuum leakage may occur. Therefore, when ordering the type without a gasket, be sure to use a commercially-available gasket or sealant when mounting.

**Dimensions: With Adapter** \* Connection thread: The male thread drawings show the type with a gasket.

**ZP2-TB10MT-H5G**

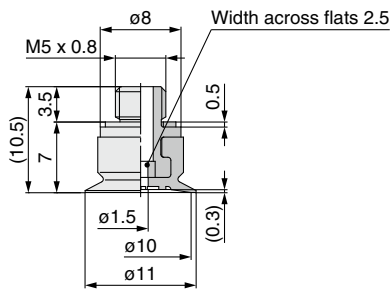

**ZP2-TB15MT-H5G**

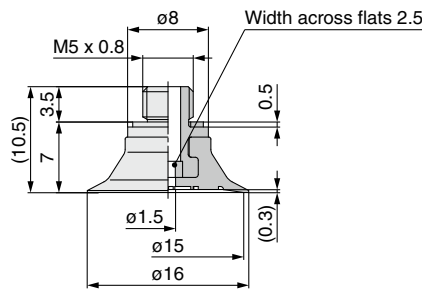

**ZP2-TB20MT-H5G**

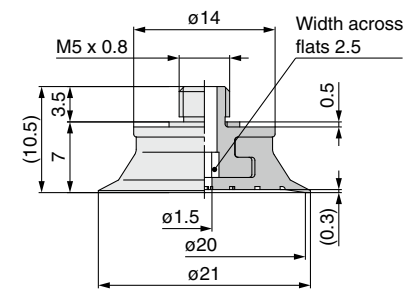

**ZP2-TB25MT-H5G**

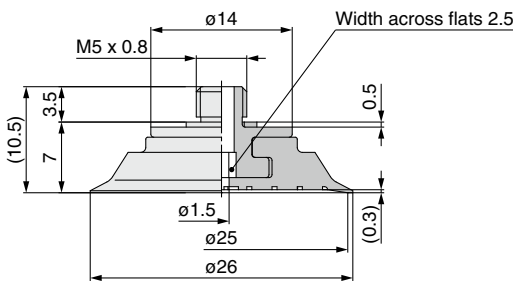

**ZP2-TB30MT-H5G**

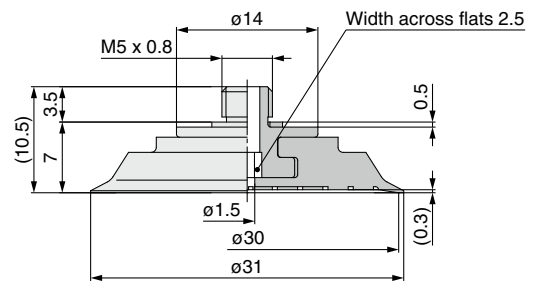

**ZP2-TB10MT-B5**

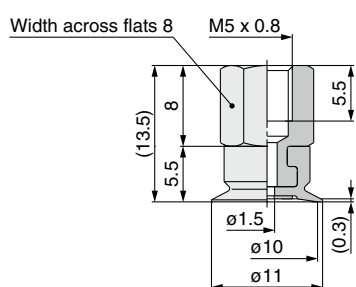

**ZP2-TB15MT-B5**

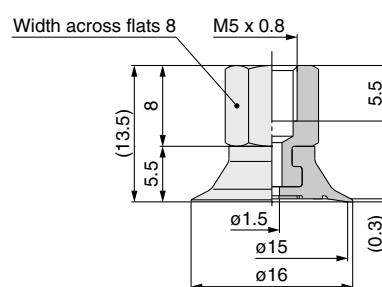

**ZP2-TB20MT-B5**

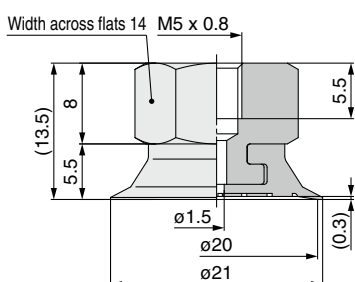

**ZP2-TB25MT-B5**

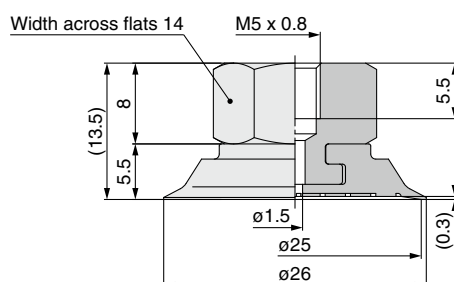

**ZP2-TB30MT-B5**

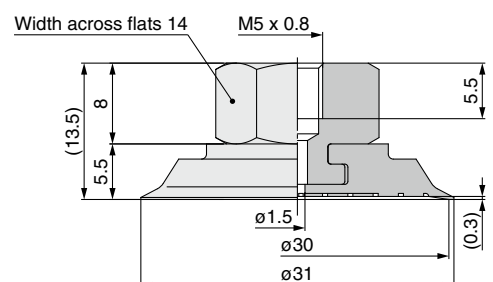

**Dimensions: With Adapter**

**ZP2-TB10MT□-A5**

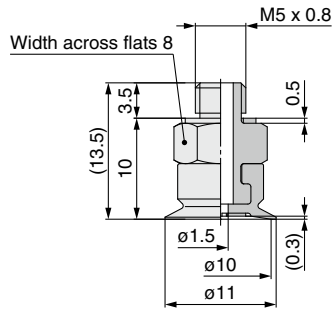

**ZP2-TB15MT□-A5**

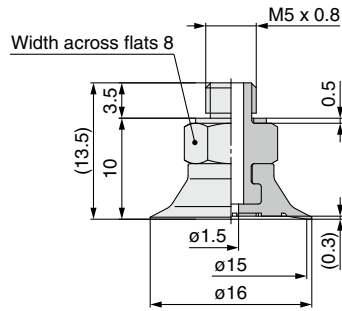

**ZP2-TB20MT□-A5**

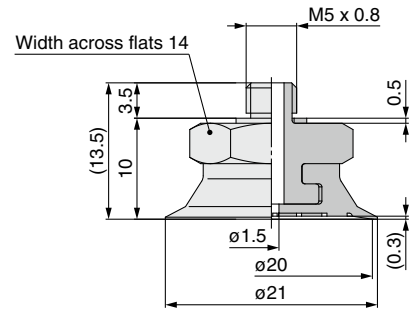

**ZP2-TB25MT□-A5**

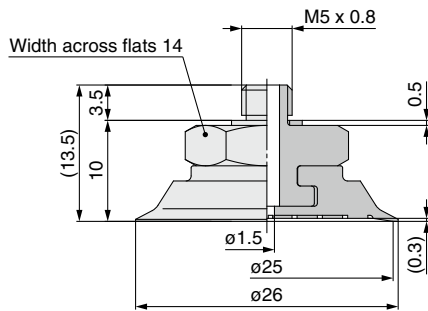

**ZP2-TB30MT□-A5**

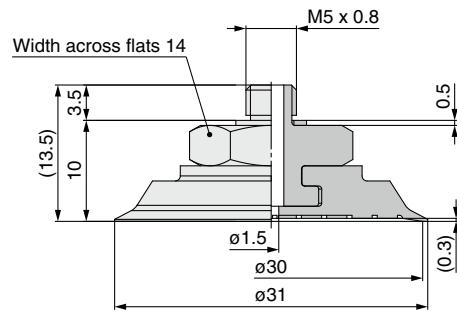

Model Selection

For Special Applications

Mark-free

For Film Adsorption

Multistage

Flat

Nozzle

Sponge

For Disk Adsorption

For Panel Holding

Ball Spline Buffer

Construction

Mounting Bracket Assembly

Precautions



# Flat Pad *ZP2 Series* Mounting Bracket Assembly

Model Selection

For Special Applications

Mark-free

For Film Adsorption

Multistage

Flat

Nozzle

Sponge

For Disk Adsorption

For Panel Holding

Ball Spine Buffer

Construction

Mounting Bracket Assembly

Precautions

## Adapter Assembly

<b>Product part no.</b>	<p style="text-align: center;">ZP2 - T ① MT □ - ②</p> <p style="text-align: center;">             Pad diameter ●      ● Connection thread (Male/Female thread)              Thin flat type (With groove) ●      ● Pad material         </p>		
<b>Component parts</b>	<p style="text-align: center;"><b>Male thread</b> (Adapter with hexagon socket head/-H5G)</p>	<p style="text-align: center;"><b>Male thread</b> (Hexagon adapter/-A5)</p>	<p style="text-align: center;"><b>Female thread</b> (Female thread adapter/-B5)</p>

		Symbol	① Pad diameter symbol							
			B10	B15	B20	B25	B30			
① Adapter	② Connection thread	Male thread	M5 x 0.8	A5		ZP2A-M08P			ZP2A-M09P	
			M5 x 0.8	H5G		ZP2A-M02P			ZP2A-M03P	
	Female thread	M5 x 0.8	B5		ZP2A-M04			ZP2A-M07		

② Gasket (Single unit)	10 pcs.*1	ZP-5G2
	100 pcs.*1	M-5G2

\*1 The gasket (single unit) sales unit is shown.

### <Flat Pad Precautions>

1. When mounting the product, be sure to tighten the product within the recommended tightening torque range.

Model	Connection thread	Tightening torque [N·m]
ZP2-TB(10, 15)MT□-(A5, H5G)	M5 x 0.8 (Male thread)	0.9 to 1.1
ZP2-TB(20, 25, 30)MT□-(A5, H5G)		1.5 to 1.7

2. When mounting the adapter with hexagon socket head specification (Product number suffix “-H5(G)”), be sure to mount the pad only after the adapter has been mounted on the device.

If a hexagon wrench is inserted into the adapter with the pad already mounted, the pad may be damaged.

Combining the adapter with a pad may be difficult depending on the pad diameter and pad material. In such cases, we recommend ordering the “-A5” specification hexagon adapter with a pad, which can be connected to the device as is.