

# Heavy Duty Stopper Cylinder

## RS2H Series

ø50, ø63, ø80

RoHS

Weight

Reduced by up to **22%**

Cylinder tube

Shortened by up to **9 mm**

(RS2H63-30 stroke)

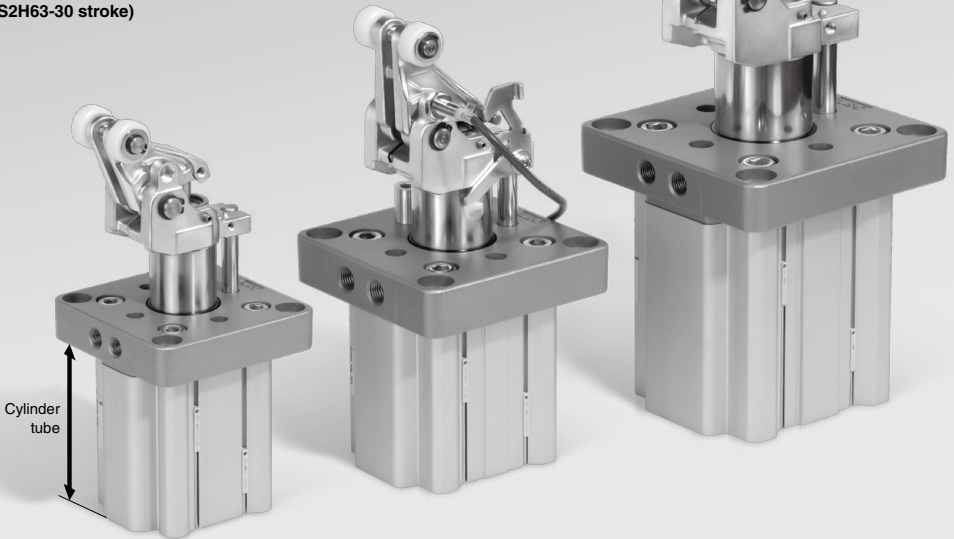

### Easy replacement of shock absorbers

Replaceable just by loosening the set screw

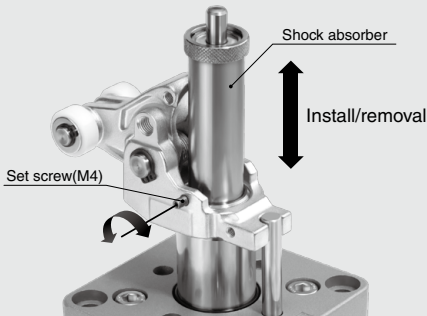

### Stop the workpiece gently with adjustable shock absorber.

Resistance value can be adjusted by rotating the adjustment dial.

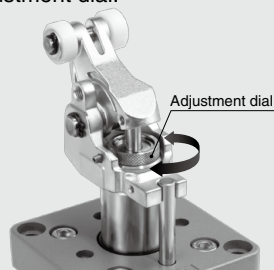

RSQ

RSG

RS2H

RSH

MIW

MIS

D-□

-X□

# Heavy Duty Stopper Cylinder

## Weight reduced by up to 22%

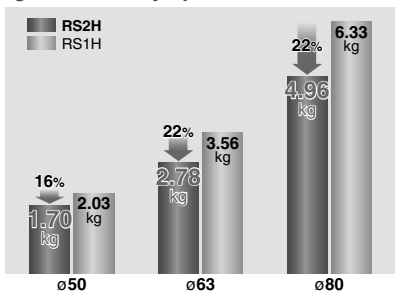

## Shorter cylinder tube

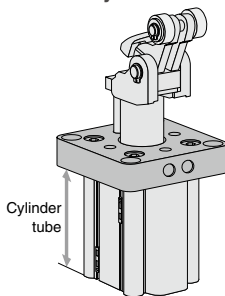

### Dimensions

Bore size (mm)	RS2H series	Shortened by*
50	84.5	8.5
63	90	9
80	121	7

\*Compared with the RS1H series.

\*The height from the cylinder mounting surface to the roller is the same.

## Better handling and visibility of the lock mechanism (Option)

The shape of the lock is changed. Easy to unlock manually, and instantly see whether it is locked.

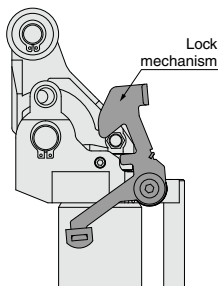

## Piping is available from 2 directions.

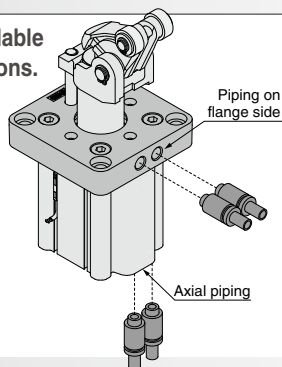

## Mounting is interchangeable with the current RS1H series.

Cylinder mounting pitch and the height from the mounting surface to the roller center are interchangeable with the RS1H series.

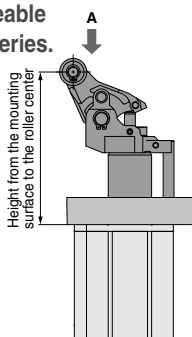
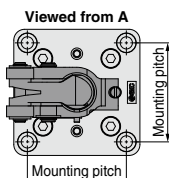

## Compact auto switch (D-M9□) and magnetic field resistant auto switch (D-P3DW) can be mounted to three sides.

Compact auto switch can be directly mounted to round switch mounting groove.

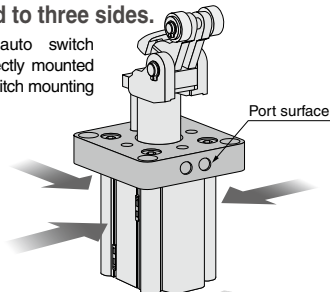

## The roller can be selected from two materials to suit the application. (Resin, Carbon steel)

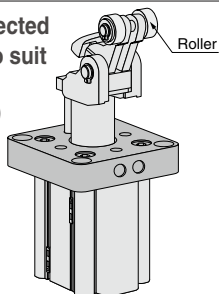

## The roller lever direction can be changed in 90° steps.

To adapt the roller lever of the stopper to the work piece direction, the roller lever can be positioned in 4 different directions in 90° steps around the piston rod.

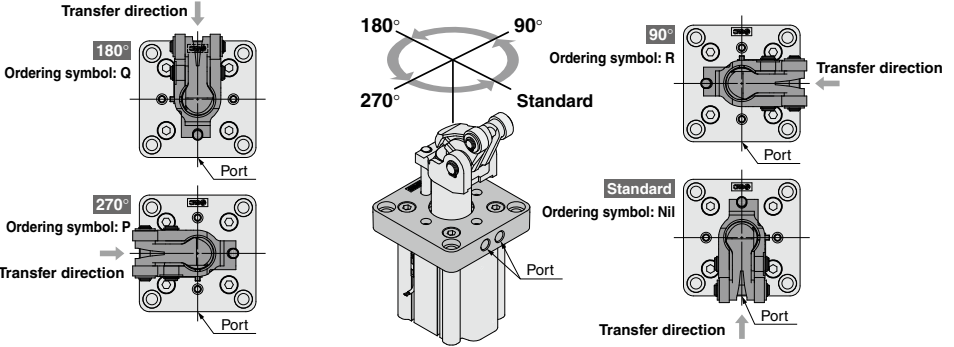

## Options

### With lock mechanism

Even in the case of a light pallet, the lock mechanism prevents the pallet from rebounding due to spring.

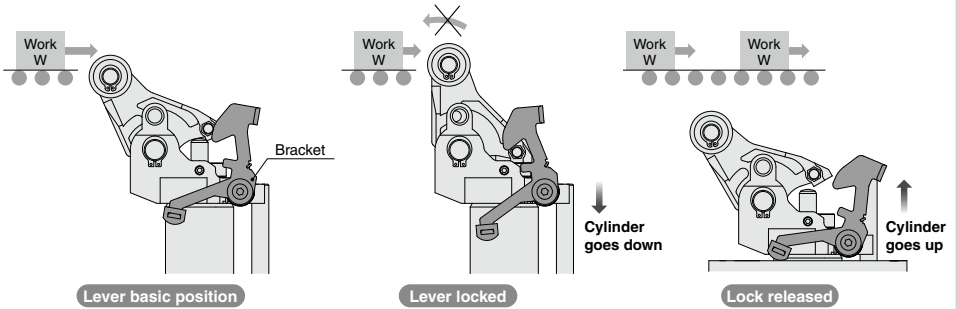

### With cancel cap

The cancel cap holds the lever horizontally allowing a pallet to pass.

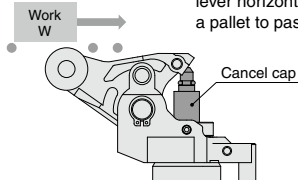

### With lever detection switch

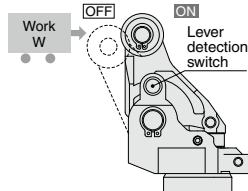

When the lever stands erect (when the energy is absorbed), the switch turns on a signal that determines the pallet has reached the stop position. (For details of lever detection switch, refer to page 595.)

## Series Variations

Series	Bore size (mm)	Standard stroke (mm)				Mounting	Action	Rod end configuration	Option			Page			
		15	20	30	40				Standard variation	With lock mechanism	With cancel cap		With lever detection switch		
RSH	20	●				Flange	Double acting	Built-in magnet	●	●	●	P.605			
	32		●						●	●	●				
RS2H	50			●					Double acting spring type	Adjustable	●		●	●	P.594
	63			●							●		●	●	
	80			●		●	●	●							

RSQ

RSG

RS2H

RSH

MIW

MIS

D-□

-X□

# RS2H Series Model Selection

## Operating Range

(Example)

**Mass of transferred object:**  
300 kg,  
**Transfer speed:** 20 m/min  
**Friction coefficient:**  $\mu = 0.1$

(How to read graph)

In following graph, find the intersection of the vertical axis representing the mass of 300 kg and the horizontal axis representing the transfer speed of 20 m/min. And select the bore size  $\phi 63$  positioned within the operating range of the cylinder.

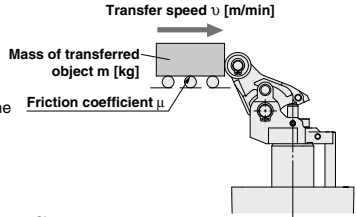

**RS2H50-30** □ □

\*The graphs indicate the values at normal temperature. (20 to 25°C)

$\mu = 0.1$

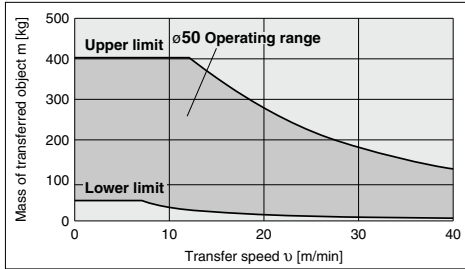

$\mu = 0.2$

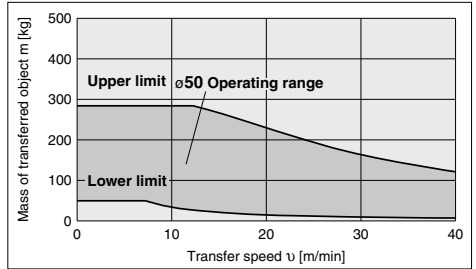

**RS2H63-30** □ □

\*The graphs indicate the values at normal temperature. (20 to 25°C)

$\mu = 0.1$

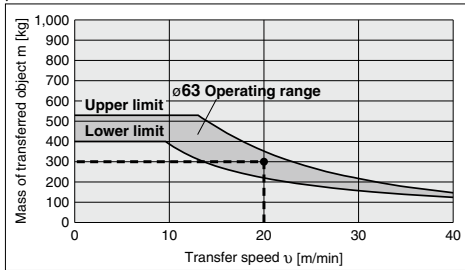

$\mu = 0.2$

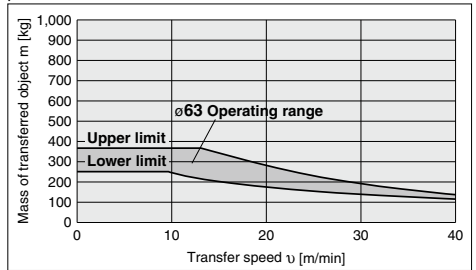

**RS2H80-40** □ □

\*The graphs indicate the values at normal temperature. (20 to 25°C)

$\mu = 0.1$

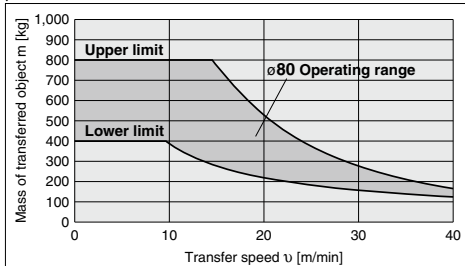

$\mu = 0.2$

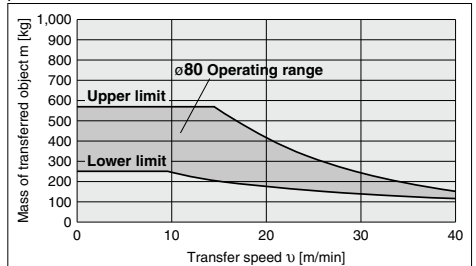

**Lateral Load and Operating Pressure**

The greater lateral load  $F$  needs higher cylinder operating pressure. Set the operating pressure by using the graph as a guideline.

**RS2H50, 63, 80**

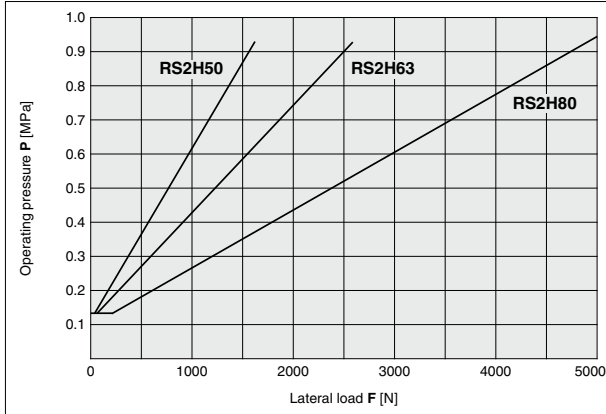

Even after the impact of the carried object is absorbed, lateral load acts on the stopper cylinder due to the friction generated between the conveyor and the carried object.

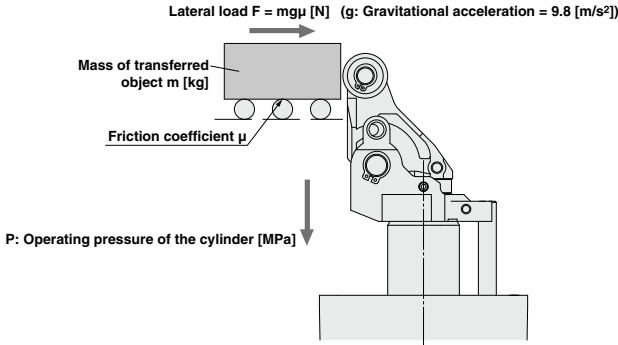

RSQ

RSG

**RS2H**

RSH

MIW  
MIS

D-□

-X□

# Heavy Duty Stopper Cylinder

# RS2H Series

ø50, ø63, ø80

RoHS

## How to Order

**RS2H50** **30** **D** **L** **M9BW**

**Bore size**

50	50 mm
63	63 mm
80	80 mm

**Port thread type**

NII	Rc
TN	NPT
TF	G

**Number of auto switches (auto switch number mounted)**

NII	2 pcs.
S	1 pc.

**Made to Order Specifications**  
For details, refer to page 595.

**Piping direction**

**NII** Flange side

**A** Axial direction (tube)

**Cylinder stroke**

30	30 mm (ø50, 63)
40	40 mm (ø80)

**Action**

D	Double acting
B	Double acting spring type
T	Single acting/spring extend

**Roller material**

L	Resin
M	Carbon steel

**Option<sup>Note 1)</sup>**

NII	Without option
D	With lock mechanism
C	With cancel cap
S	With lever detection switch <sup>Note 2)</sup>

**Auto switch**

NII	Without auto switch (Built-in magnet)
-----	---------------------------------------

\*For applicable auto switches, refer to the table below.  
\*Auto switches are shipped together, (but not assembled).

**Positional relationship of lever and port**

<b>NII</b>		<b>Q</b>	
<b>P</b>		<b>R</b>	

Note 1) Options can be combined. Indicate the option symbols according to the priority order of D,C,S.  
Note 2) For details of the lever detection switch alone, refer to page 595.

## Applicable Auto Switches/Refer to pages 941 to 1067 for further information on auto switches.

Type	Special function	Electrical entry	Indicator light	Wiring (Output)	Load voltage		Auto switch model		Lead wire length (m)				Pre-wired connector	Applicable load	
					DC	AC	Perpendicular	In-line	0.5 (NII)	1 (M)	3 (L)	5 (Z)			
Solid state auto switch	—	Grommet	Yes	3-wire (NPN)	5 V, 12 V	—	<b>M9NV</b>	<b>M9N</b>	●	●	○	○	IC circuit	Relay, PLC	
				3-wire (PNP)			<b>M9PV</b>	<b>M9P</b>	●	●	○	○			
				2-wire	<b>M9BV</b>		<b>M9B</b>	●	●	○	○				
				3-wire (NPN)	<b>M9NVW</b>		<b>M9NW</b>	●	●	○	○				
	3-wire (PNP)			<b>M9PVW</b>	<b>M9PW</b>		●	●	○	○					
	2-wire			<b>M9BWW</b>	<b>M9BW</b>		●	●	○	○					
	3-wire (NPN)			<b>M9NAV</b> <sup>*1</sup>	<b>M9NA</b> <sup>*1</sup>		○	○	●	○	○	IC circuit			
	3-wire (PNP)			<b>M9PAV</b> <sup>*1</sup>	<b>M9PA</b> <sup>*1</sup>		○	○	●	○	○				
2-wire	<b>M9BAV</b> <sup>*1</sup>	<b>M9BA</b> <sup>*1</sup>	○	○	●	○	○	—							
Magnetic field resistant (2-color display)	2-wire (Non-polar)	—	—	—	<b>P3DWA</b>	●	—	●	○	○	—				
Reed auto switch	—	Grommet	Yes	3-wire (NPN equivalent)	—	5 V	—	<b>A96V</b>	<b>A96</b>	●	●	—	—	IC circuit	—
				No	2-wire	24 V	12 V	100 V	<b>A93V</b> <sup>*2</sup>	<b>A93</b>	●	●	●	—	—
					5 V, 12 V	100 V or less	<b>A90V</b>	<b>A90</b>	●	●	●	—	—	IC circuit	—

\*1 Water resistant type auto switches can be mounted on the above models, but in such case SMC cannot guarantee water resistance.

Consult with SMC regarding water resistant types with the above model numbers.

\*2 1 m type lead wire is only applicable to D-A93.

\*Lead wire length symbols    0.5 m.....NII    (Example) M9NW    \*Solid state auto switches marked with a "○" symbol are produced upon receipt of order.  
    1 m.....M    (Example) M9NWM  
    3 m.....L    (Example) M9NWL  
    5 m.....Z    (Example) M9NWZ

\*Since there are other applicable auto switches than listed, refer to page 599 for details.

\*For details about auto switches with pre-wired connector, refer to pages 1014 and 1015.

\*Auto switches are shipped together, (but not assembled).



Made to Order

**Made to Order: Individual Specifications**  
(For details, refer to pages 601 and 602.)

Symbol	Specifications
-X2464	Built-in low resistive force shock absorber
-X2541	Built-in shock absorber with scraper

Made to Order

**Made to Order Common Specifications**  
(For details, refer to page 1896-1.)

Symbol	Specifications
-XC102	Lock release specification

## Specifications

Bore size (mm)	50	63	80
<b>Action</b>	Double acting, Double acting spring type, Single acting/spring extend		
<b>Rod end configuration</b>	Lever with built-in shock absorber		
<b>Fluid</b>	Air		
<b>Proof pressure</b>	1.5 MPa		
<b>Max. operating pressure</b>	1.0 MPa		
<b>Ambient and fluid temperature</b>	-10 to 60°C (No freezing)		
<b>Lubrication</b>	Not required (non-lube)		
<b>Cushion</b>	Rubber bumper		
<b>Stroke length tolerance</b>	$^{+1.4}$ <sub>0</sub>		
<b>Mounting</b>	Flange		
<b>Port size (Rc, NPT, G)</b>	1/8	1/4	1/4

## Standard Strokes

Bore size (mm)	Standard stroke (mm)
50	30
63	30
80	40

## Weight

Action	Rod end configuration	Bore size (mm)	Weight (kg)
Double acting	Lever with built-in shock absorber	50	1.70
		63	2.78
		80	4.96

## Lever Detection Switch (Proximity Switch)

**Proximity Switch Specifications/**  
**Maker: OMRON Corporation**

Model	E2E-X2D1-N
<b>Output type</b>	Normally open
<b>Power supply voltage (Operating voltage range)</b>	12 to 24 VDC (10 to 30 VDC) Ripple 10% or less (P-P)
<b>Current consumption (Leakage current)</b>	0.8 mA or less
<b>Response frequency</b>	1.5 kHz
<b>Control output (Chest)</b>	3 to 100 mA
<b>Indicator LED</b>	Operation indication (Red LED), Set operation indication (Green LED)
<b>Ambient temperature</b>	-25 to 70°C (No freezing)
<b>Operating ambient humidity</b>	35 to 95%RH
<b>Residual voltage</b> <small>Note 1)</small>	3 V or less
<b>Withstand voltage</b> <small>Note 2)</small>	1000 VAC
<b>Vibration</b>	Endurance 10 to 55 Hz, Double amplitude 1.5 mm X, Y, Z direction each 2 h
<b>Impact</b>	Endurance 500 m/s <sup>2</sup> (approx. 50 G), X, Y, Z direction each 10 times
<b>Enclosure</b>	IEC standards IP67 (Immersion proof and oil proof by JEM standards IP67G)

Note 1) At load current 100 mA and cord length of 2 m  
Note 2) Between case and whole live part

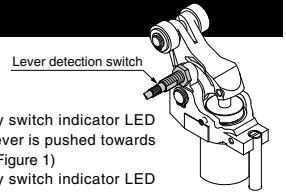

### <Mounting position>

Confirm that the proximity switch indicator LED turns to green when the lever is pushed towards the proximity switch side. (Figure 1)  
Confirm that the proximity switch indicator LED turns to green when the lever is pushed towards the opposite side from the proximity switch. (Figure 2)  
Then, rotate the lever by 90° to confirm that the indicator LED of the proximity switch (red, green) does not turn on.  
Fix the cylinder with screws included as accessories after confirming that there is no interference between the lever and the proximity switch.

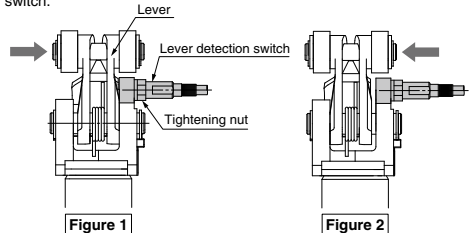

## Dimensions

### E2E-X2D1-N

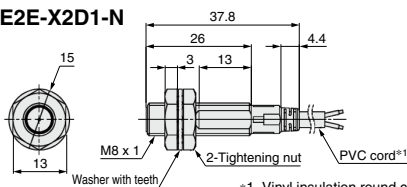

\*1 Vinyl insulation round cord, 2 cores, 2 m  
ø4 (Conductor area: 0.3 mm<sup>2</sup>, Insulator O.D.: 1.15 mm)

## Output Circuit

### E2E-X2D1-N/2-wire

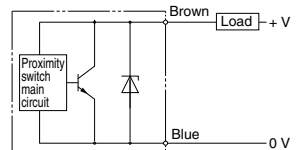

RSQ

RSQ

RS2H

RSH

MIW  
MIS

D-□

-X□

# RS2H Series

## Construction

### Double acting (DL, DM)

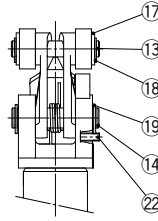
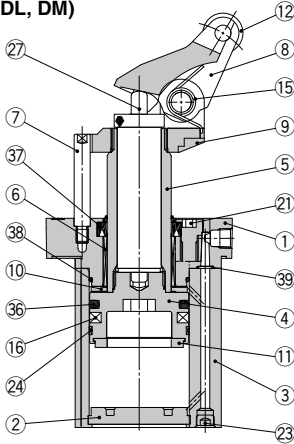

Double acting spring type  
(BL, BM)

Single acting  
(TL, TM)

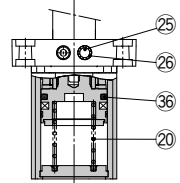
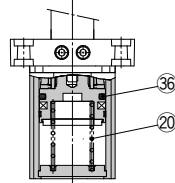

### Options (With lock mechanism and cancel cap) With lock mechanism (-D)

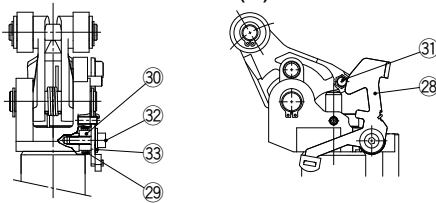

### When cancel cap is used (-C)

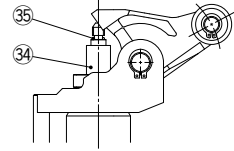

### Component Parts

No.	Description	Material	Note
1	Rod cover	Aluminum alloy	Metallic painted
2	Bottom plate	Aluminum alloy	Hard anodized
3	Cylinder tube	Aluminum alloy	Hard anodized
4	Piston	Aluminum alloy	Chromated
5	Piston rod	Carbon steel	Hard chrome plated
6	Bushing	Bearing alloy	
7	Guide rod	Carbon Steel	Hard chrome plated
8	Lever	Cast iron	Zinc chromated
9	Lever holder	Cast iron	Zinc chromated
10	Bumper A	Urethane	
11	Bumper B	Urethane	
12	Roller	Resin	-□□L
		Carbon steel	-□□M
13	Roller pin	Carbon steel	
14	Lever pin	Carbon steel	
15	Lever spring	Steel wire	
16	Magnet	—	
17	Flat washer	Steel wire	Zinc chromated
18	Type C retaining ring for shaft	Carbon tool steel	
19	Type C retaining ring for shaft	Carbon tool steel	
20	Return spring	Steel wire	-□□/□□
21	Hexagon socket head cap screw	Chrome molybdenum steel	Zinc chromated
22	Hexagon socket head set screw	Chrome molybdenum steel	Zinc chromated
23	Hexagon socket head plug	Carbon steel	Zinc chromated
24	Wear ring	Resin	
25	Element	Bronze	-□□TL/□□TM
26	Retaining ring	Carbon tool steel	-□□TL/□□TM
27	Shock absorber	—	
28	Bracket assembly	Carbon steel	Used for -D (Lock type)

### Component Parts

No.	Description	Material	Note
29	Bracket spring	Steel wire	Used for -D (Lock type)
30	Bracket spacer	Carbon steel	Used for -D (Lock type)
31	Lock pin	Carbon steel	Used for -D (Lock type)
32	Hexagon socket head cap screw	Chrome molybdenum steel	Used for -D (Lock type)
33	Flat washer	Carbon steel	Used for -D (Lock type)
34	Cancel cap	Aluminum alloy	Used for -C (Cancel cap type)
35	O-ring	NBR	Used for -C (Cancel cap type)
36	Piston seal	NBR	
37	Rod seal	NBR	
38	Tube gasket	NBR	
39	O-ring	NBR	

### Replacement Parts/Seal Kit

Bore size (mm)	Kit no.		Contents
	Double acting	Double acting spring type / Single acting	
50	RS2H50D-PS	RS2H50T-PS	Set of nos. above
63	RS2H63D-PS	RS2H63T-PS	③⑥ to ③⑨
80	RS2H80D-PS	RS2H80T-PS	(excluding ③⑦)

\*Seal kit includes ③⑥ to ③⑨ (excluding ③⑦).

Order the seal kit based on each bore size.

\*Since the seal kit does not include a grease pack, order it separately.

Grease pack part no.: GR-S-010 (10 g)

### Replacement Parts/Shock Absorber

Bore size (mm)	Order no.
50	RS2H-R50
63	RS2H-R63
80	RS2H-R80



## Dimensions

### Basic

ø50 to ø80

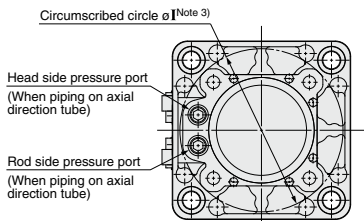

View A

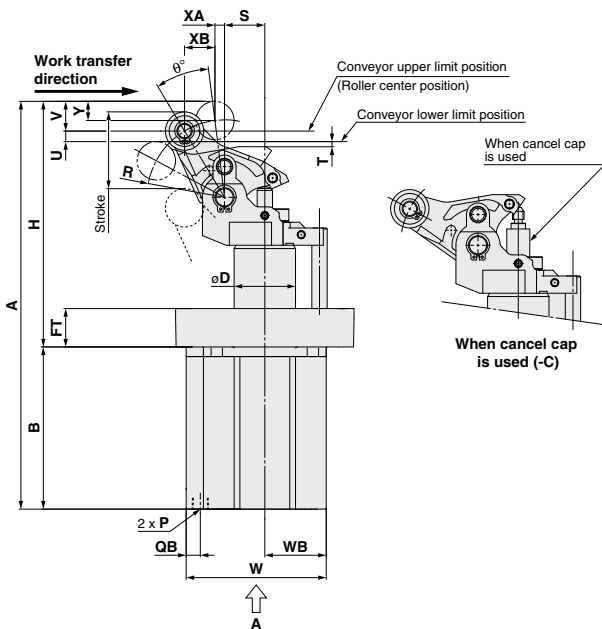
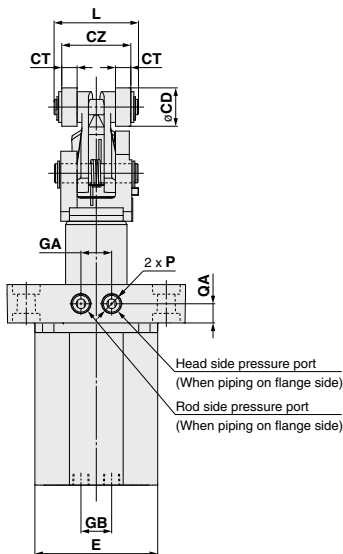
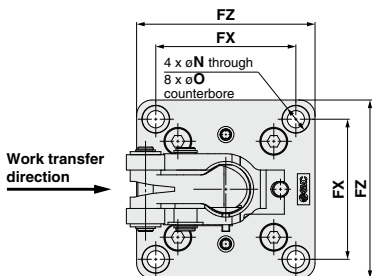

Model	Stroke	A	B	CD	CT	CZ	D	E	FT	FX	FZ	GA	GB	H	Circumscribed circle	I	L	N	O	QA	QB
RS2H50	30	212.5	84.5	20	8	36	32	64	20	73	93	16	16	128	85	44	9	14 depth 5	10	8	
RS2H63	30	234.5	90	20	10	45	40	77	25	90	114	24	24	144.5	103	53	11	18 depth 6	12.5	8.5	
RS2H80	40	292.5	121	25	10	45	50	98	25	110	138	24	35	171.5	132	54.5	13	20 depth 6	12.5	10	

Model	Stroke	R	S	T	U	V	W	WB	XA	XB	Y	θ°
RS2H50	30	40	21	2	5.5	15.5	73	32	5	15.8	10	24
RS2H63	30	47	24.5	3.5	6.4	16	87.5	38.5	5	18.7	10	24
RS2H80	40	54	31	3	6.7	19	109	49	6	20.6	12.5	23

Model	P (Piping port)		
	NII	TN	TF
RS2H50	Rc1/8	NPT1/8	G1/8
RS2H63	Rc1/4	NPT1/4	G1/4
RS2H80	Rc1/4	NPT1/4	G1/4

Note 1) Dimensions when equipped with auto switch are the same as drawing above.

Note 2) The figure shows an extended piston rod.

Note 3) Circumscribed circle øI means that diameter of the circle circumscribed to the cylinder angles.

Mounting hole must be ø (I + 1).

Be careful of the interference between the lever and the mounting base when mounted from the lever side.

Thus, the thickness of the mounting base must be the values shown below or less.

(RS2H50: 10 mm RS2H63: 15 mm RS2H80: 18 mm)

Note 4) Set the conveyor height within the range from the lower limit position to the upper limit position (U dimension) shown in the figure.

RSQ

RSG

RS2H

RSH

MIW

MIS

D-□

-X□

# RS2H Series

## Dimensions

With lock mechanism  
 $\varnothing 50$  to  $\varnothing 80$

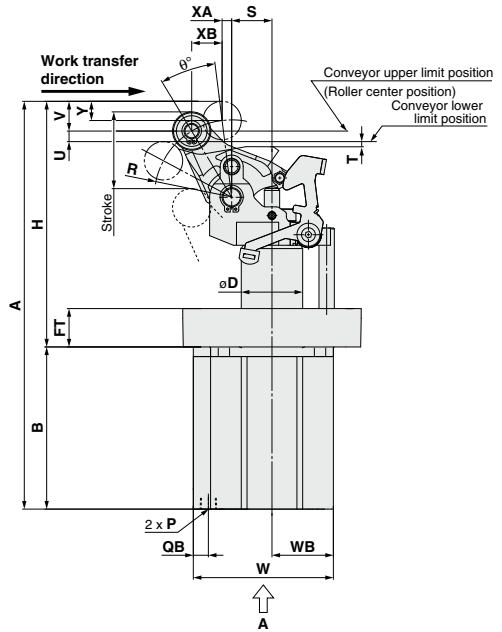
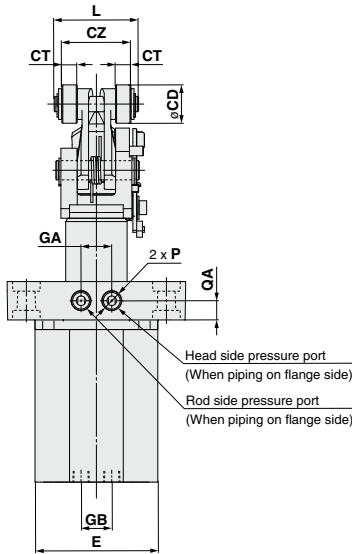
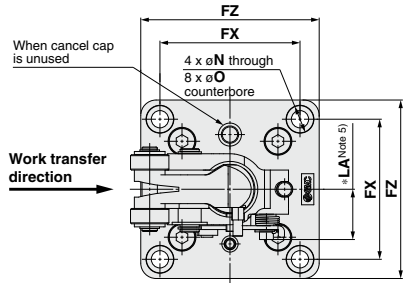
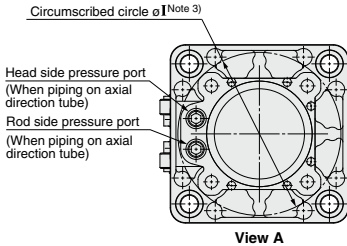

Model	Stroke	A	B	CD	CT	CZ	D	E	FT	FX	FZ	GA	GB	H	Circumscribed circle $\varnothing I$	L	$\approx LA$ (Note 5)	N	O	QA
RS2H50	30	212.5	84.5	20	8	36	32	64	20	73	93	16	16	128	85	44	26	9	14 depth 5	10
RS2H63	30	234.5	90	20	10	45	40	77	25	90	114	24	24	144.5	103	53	31	11	18 depth 6	12.5
RS2H80	40	292.5	121	25	10	45	50	98	25	110	138	24	35	171.5	132	54.5	38	13	20 depth 6	12.5

Model	Stroke	QB	R	S	T	U	V	W	WB	XA	XB	Y	$\theta^\circ$
RS2H50	30	8	40	21	2	5.5	15.5	73	32	5	15.8	10	24
RS2H63	30	8.5	47	24.5	3.5	6.4	16	87.5	38.5	5	18.7	10	24
RS2H80	40	10	54	31	3	6.7	19	109	49	6	20.6	12.5	23

Model	P (Piping port)		
	NII	TN	TF
RS2H50	Rc1/8	NPT1/8	G1/8
RS2H63	Rc1/4	NPT1/4	G1/4
RS2H80	Rc1/4	NPT1/4	G1/4

Note 1) Dimensions when equipped with auto switch are the same as drawing above.

Note 2) The figure shows an extended piston rod.

Note 3) Circumscribed circle  $\varnothing I$  means that diameter of the circle circumscribed to the cylinder angles.

Mounting hole must be  $\varnothing (I + 1)$ .

Be careful of the interference between the lever and the mounting base when mounted from the lever side.

Thus, the thickness of the mounting base must be the values shown below or less.

(RS2H50: 10 mm RS2H63: 15 mm RS2H80: 18 mm)

Note 4) Set the conveyor height within the range from the lower limit position to the upper limit position (U dimension) shown in the figure.

Note 5) Dimensions other than those marked \* (LA) are the same as the basic type (no locking type).

# Auto Switch Mounting 1

## Auto Switch Proper Mounting Position (Detection at Stroke End)

- D-M9□
- D-M9□W
- D-M9□AV
- D-M9□V
- D-M9□WV
- D-M9□A
- D-A9□
- D-A9□V

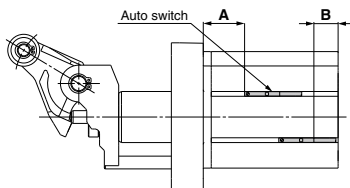

### Auto Switch Proper Mounting Position

(mm)

Auto switch model \ Bore size	D-M9□ D-M9□W D-M9□AV		D-M9□V D-M9□WV		D-M9□A		D-A9□ D-A9□V	
	A	B	A	B	A	B	A	B
50	23.5	9.0	23.5	11.0	23.5	7.0	19.5	10.5 (13.0)
63	25.5	12.5	25.5	14.5	25.5	10.5	21.5	14.0 (16.5)
80	39.5	19.5	39.5	21.5	39.5	17.5	35.5	21.0 (23.5)

The values inside ( ) are for the D-A96/A96V.

Note) Adjust the auto switch after confirming the operating conditions in the actual setting.

### D-P3DWA□

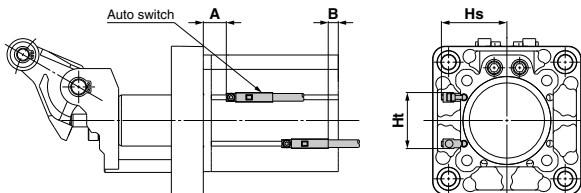

### Auto Switch Proper Mounting Position

(mm)

Auto switch model \ Bore size	D-P3DWA□			
	A	B	Hs	Ht
50	19	6.5	43	35
63	21	10	48.5	44
80	35	17	56.5	54

Note) Adjust the auto switch after confirming the operating conditions in the actual setting.

## Operating Range

(mm)

Auto switch model	Bore size		
	50	63	80
D-M9□/M9□V D-M9□W/M9□WV D-M9□A/M9□AV	6	6	7
D-P3DWA□	5.5	6.5	6.5
D-A9□/A9□V	8	9	9

\*Since the operating range is provided as a guideline including hysteresis, it cannot be guaranteed. (assuming approximately ±30% dispersion)  
It may vary substantially depending on an ambient environment.

Other than the applicable auto switches listed in "How to Order", the following auto switches are mountable.

- \*Normally closed (NC=b contact) solid state auto switches (D-M9□E(V)) are also available. For details, refer to page 1592-1.
- \*With pre-wired connector is also available for solid state auto switches. For details, refer to pages 1014 and 1015.

RSQ

RSG

RS2H

RSH

MIW

MIS

D-□

-X□

# Auto Switch Mounting 2

## Auto Switch Mounting Brackets/Part No.

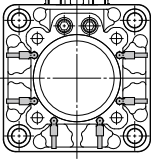
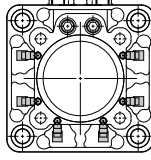
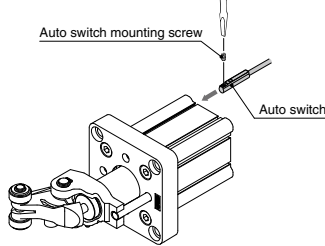
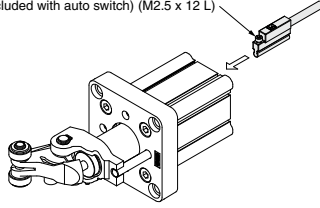
Applicable auto switches	<b>D-M9□/M9□V</b> <b>D-M9□W/M9□WV</b> <b>D-M9□A/M9□AV</b> <b>D-A9□/A9□V</b>	<b>D-P3DWA</b>										
Bore size (mm)	<b>ø50 to ø80</b>	<b>ø50 to ø80</b>										
Auto switch mounting surfaces	Surfaces with auto switch mounting slot	Surfaces with auto switch mounting slot										
												
Mounting of auto switch	 <ul style="list-style-type: none"> <li>When tightening the auto switch mounting screw, use a watchmakers' screwdriver with a handle 5 to 6 mm in diameter.</li> </ul> <p><b>Tightening Torque for Auto Switch Mounting Screw (N·m)</b></p> <table border="1"> <thead> <tr> <th>Auto switch model</th> <th>Tightening torque</th> </tr> </thead> <tbody> <tr> <td><b>D-M9□(V)</b></td> <td rowspan="3">0.05 to 0.15</td> </tr> <tr> <td><b>D-M9□W(V)</b></td> </tr> <tr> <td><b>D-A93</b></td> </tr> <tr> <td><b>D-M9□A(V)</b></td> <td>0.05 to 0.10</td> </tr> <tr> <td><b>D-A9□(V) (Excludes the D-A93)</b></td> <td>0.10 to 0.20</td> </tr> </tbody> </table>	Auto switch model	Tightening torque	<b>D-M9□(V)</b>	0.05 to 0.15	<b>D-M9□W(V)</b>	<b>D-A93</b>	<b>D-M9□A(V)</b>	0.05 to 0.10	<b>D-A9□(V) (Excludes the D-A93)</b>	0.10 to 0.20	<ol style="list-style-type: none"> <li>Insert the mounting bracket into the mating groove of the cylinder tube.</li> <li>Check the detecting position of the auto switch and fix the auto switch firmly with the hexagon socket head cap screw (M2.5 x 12 L).*</li> <li>If the detecting position is changed, go back to step ①.</li> </ol> <p>Note 1) Ensure that the auto switch is covered with the mating groove to protect the auto switch.</p> <p>Note 2) The tightening torque for the hexagon socket head cap screw (M2.5 x 12 L) is 0.2 to 0.3 N·m.</p> <p>Hexagon socket head cap screw (Included with auto switch) (M2.5 x 12 L)</p> 
Auto switch model	Tightening torque											
<b>D-M9□(V)</b>	0.05 to 0.15											
<b>D-M9□W(V)</b>												
<b>D-A93</b>												
<b>D-M9□A(V)</b>	0.05 to 0.10											
<b>D-A9□(V) (Excludes the D-A93)</b>	0.10 to 0.20											

Note) Auto switch mounting brackets and auto switches are enclosed with the cylinder for shipment.  
 For an environment that needs the water-resistant auto switch, select the D-M9□A(V) type.



## 1 Built-in Low Resistive Force Shock Absorber

Symbol  
**-X2464**

Heavy duty stopper cylinder with a built-in shock absorber applicable to loads lighter than the operating range of the standard product.

RS2H 50 Standard model no. - **X2464**

● Built-in low resistive force shock absorber

### Specifications

Bore size	ø50 only
Operating Range	Refer to the graph below.
Specifications other than the above	Same as standard product

Dimensions: Same as standard product

### Operating Range

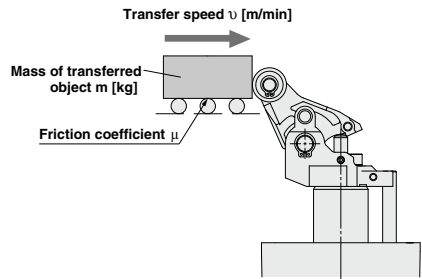
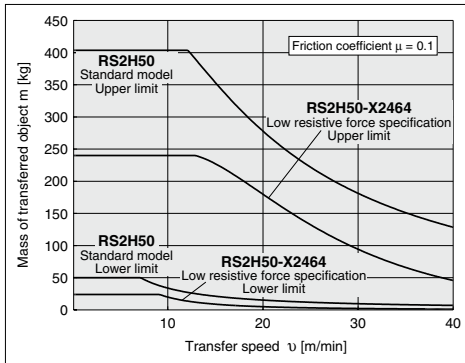

### Operating Range Lower Limit Expansion

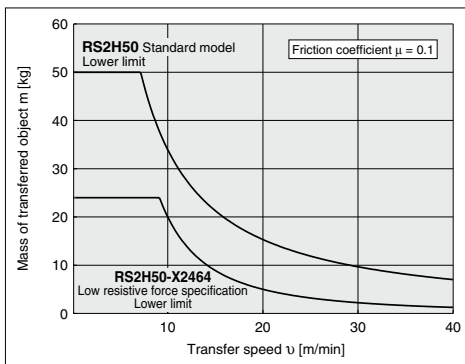

### Precautions

1. Adjust the shock absorber corresponding to the energy of the transferred object before using it.
2. When using a cylinder at around the lower limit of the operating range, it is recommended to use a cylinder with lock mechanism. Additionally, be aware that the transferred object may be pushed back due to the return force of the shock absorber.
3. Shock absorber order no.: RS2H-R50-X2464  
Mounting is interchangeable with the standard shock absorber (RS2H-R50).

\* The graphs indicate the values at normal temperature. (20 to 25°C)

RSQ

RSG

RS2H

RSH

MIW  
MIS

D-□

-X□

## 2 Built-in Shock Absorber with Scrapper

**-X2541**

A scrapper is mounted on the piston rod sliding parts of the shock absorber. This can reduce the entry of dust, foreign matter, and coolant.

### How to Order

RS2H  - **X2541**

● Built-in shock absorber with scrapper

**Specifications: Same as standard type**

**Dimensions: Same as standard product**

The shock absorber with scrapper can be replaced individually.

\* Mounting is interchangeable with the standard shock absorber (RS2H-R□).

Stopper cylinder Bore size	Part no.
ø50	RS2H-R50-X2666
ø63	RS2H-R63-X2666
ø80	RS2H-R80-X2666



## RS2H Series

# Specific Product Precautions 1

Be sure to read this before handling the products. Refer to back page 50 for Safety Instructions and pages 3 to 12 for Actuator and Auto Switch Precautions.

### Instruction

## ⚠ Caution

### 1. Shock absorber capacity variable adjustment method

To stop the work gently, loosen the set screw (M4) on the stopper and turn the shock absorber dial according to the energy value of the transferred object to select the optimum absorption position (retardation value). After adjustment, tighten the set screw firmly to secure the shock absorber dial.

• Set screw (M4) tightening torque: 1.5 N·m

Note1) Cautions for adjustment

When adjusting the shock absorber resistive force value, first try the maximum value and then proceed to smaller values. Confirm that the adjustment position is appropriate to avoid impact and bounce when the carried object hits the shock absorber.

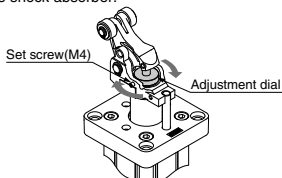

Note 2) Please consult SMC if shock absorption is not soft, even after adjusting the shock absorber with the above method.

### 2. How to change the positional relationship between the transfer and piping directions

The positional relationship between the transfer and piping directions can be changed in 90° increments.

Apply a wrench, etc., to the width across flats of the guide rod end to remove the guide rod. The lever is released to allow rotations in 90° increments. When mounting the guide rod, apply glue for screw to the guide rod screw before tightening.

• Guide rod tightening torque

ø50, ø63, ø80: 5.2 N·m

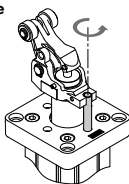

### 3. How to replace shock absorber during maintenance

Loosen the shock absorber set screw (M4) on the stopper to incline the lever by 90° and pull out the shock absorber.

Note) Cautions for assembly

After replacing the shock absorber, tighten the set screw firmly and apply grease to the shock absorber rod end surface.

• Set screw (M4) tightening torque: 1.5 N·m

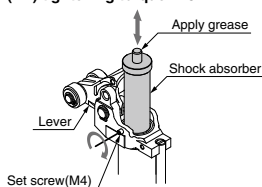

### Selection

## ⚠ Danger

### 1. Use the equipment only within the specified operating range.

If the condition exceeds the specified operating range, it will cause excessive impact or vibration to the stopper cylinder, leading to possible damage.

## ⚠ Caution

### 1. Do not collide the pallet while the lever is standing erect.

For the lever with built-in shock absorber, do not collide the next pallet while the lever is standing erect. Otherwise, all energy will be applied to the cylinder body.

### 2. When stopping a load directly connected to the cylinder at an intermediate position:

Apply the operating range in the catalog only in these cases where the stopper cylinder is used to stop pallets on a conveyor belt. When using the stopper cylinder to stop loads directly connected to a cylinder or some other equipment, a lateral load is applied as the cylinder thrust. Please consult SMC in such cases.

### Mounting

## ⚠ Caution

### 1. Do not apply rotational torque to the cylinder rod.

Align the cylinder parallel to the working face of the pallet working when installing in order to prevent rotational torque working on the cylinder rod.

### 2. Do not scratch or gouge the sliding part of the piston rod or guide rod.

Scratches and gouges may damage the packing, causing air leakage or malfunction.

### Operation

## ⚠ Caution

### 1. For a cylinder with lock mechanism, do not apply an external force from the opposite side when the lever is locked.

Lower the cylinder before adjusting the conveyor or moving the pallet.

### 2. For a cylinder with lock mechanism, do not collide the pallet and the roller when the lever is locked.

If the pallet collides with the roller in the locked state, it may cause lever malfunction. (The lever is released when the cylinder is fully retracted.)

### 3. Some structural backlash is present in the lever lock mechanism.

As the stopping position of the pallet can be affected by the weight of the object being transferred, the operating conditions of the conveyor, etc., the stopping position may vary. Please contact SMC if a higher level of stopping accuracy is required for the pallet.

### 4. Do not let your hand become caught when operating the cylinder.

The lever holder goes up and down while the cylinder is in operation. Pay sufficient attention not to let your hand or fingers become caught between the rod cover and the lever holder.

RSQ

RSG

RS2H

RSH

MIW

MIS

D-□

-X□



## RS2H Series

# Specific Product Precautions 2

Be sure to read this before handling the products. Refer to back page 50 for Safety Instructions and pages 3 to 12 for Actuator and Auto Switch Precautions.

### Operation

#### Caution

5. Do not let water, cutting oil or dust splash on the equipment.

It can cause oil leakage and malfunction of the shock absorber.

6. The stopping condition of the carried object may vary due to changes in ambient temperature or changes in the shock absorber resistance over time.

Check the stopping condition periodically and adjust the shock absorber resistance as necessary.

7. For a cylinder with lock mechanism, do not remove the grease applied to the lock pin (Refer to the figure below).

When using the cylinder continuously with no grease applied, the lock and unlock may not operate correctly due to unusual wear of the lock pin. Check the grease application state periodically and apply the grease when necessary.

The grease to be applied is available as grease pack. When the grease pack is required, order it using the part number shown below.

Grease pack part number: GR-S-010 (10g)

(\* The grease to be applied is the same as that used for the cylinder.)

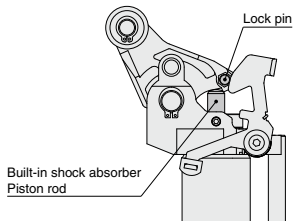

Similarly, be careful not to remove the grease from the piston rod end of the built-in shock absorber. Check the grease application state periodically.