

Water Cooled Oil Cooler

HOWF Series

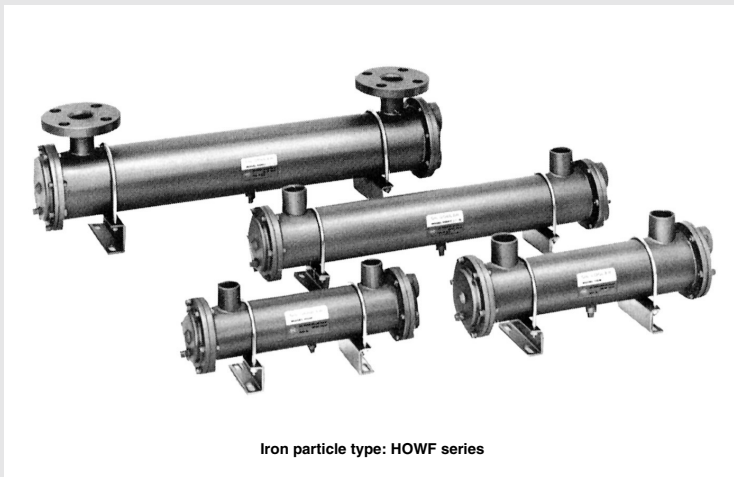

FH

HOW

Series	Heat transfer area (Inside pipe) (m ²)	Heat exchange volume (kW)	Flow rate (L/min)		Page
			Oil side	Cooling water side	
Oil Cooler: Iron particle type (Fixed pipe type) HOWF series	0.077, 0.13, 0.21, 0.34 0.56, 0.83, 1.28	5.2 to 73	20 to 800	40 to 125	534

Fixed Pipe Type Oil Cooler

HOWF Series

Water Cooled: Iron Particle Type

High heat transfer coefficient through the effects of turbulence

The metal particles reliably generate turbulence by agitating the fluid, resulting in effective cooling without unevenness.

Compact design requiring less installation space

The compact design is only 1/2 to 1/5 the size of current oil coolers. Installation requires very little space.

Large heat transfer area

The metal particles firmly welded to the outer surface of the heat transfer pipes provide several times the heat transfer performance of fin tube configurations.

Flexible installation orientation

U-bolts are used to mount the oil cooler, providing plenty of flexibility with regard to the mounting orientation and method.

Simple structure

The baffle is also welded to a metal particle layer, a design that eliminates problems that previously tended to occur at the joins between the heat transfer pipes and baffles in current oil coolers.

Minimal pressure drop

The single-baffle structure increases the fluid path area, and the metal particles are 2 mm in diameter and pose no clogging danger.

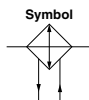

Specifications

Max. operating pressure	(Oil and Water sides) 1.0 MPa
Proof pressure	(Oil and Water sides) 1.5 MPa
Fluid temperature	Oil side: Max. 100°C/Water side: Max. 50°C
Cooling water	Industrial water, Tap water
Fluid cooled	General petroleum-based hydraulic fluid, Lubricating oil, Non-flammable oil (water-glycol)
Heat transfer medium	Copper tube and iron particles (iron particles surface treated with copper alloy)
Connection ^{Note)}	Oil side: Threaded or Flange/Water side: Threaded

Note) Refer to "Dimensions". Threads conform to JIS B 0203 parallel female thread (oil side) and tapered female thread (water side). Flanges conform to JIS B 2220 (JIS 10K FF).

Model

Model	Heat transfer area (inside pipe) (m ²)	Heat exchange volume ^{Note 1)} (kW)	Oil side ^{Note 3)}		Cooling water side ^{Note 2)}		Weight (kg)
			Flow rate range (L/min)	Flow rate (L/min)	Pressure drop (MPa)		
HOWF7-06	0.077	5.2	20 to 100	40	0.02	7	
HOWF11-06	0.13	8.4	30 to 150	40	0.02	9	
HOWF22-08	0.21	14	40 to 250	55	0.02	12	
HOWF37-08	0.34	21	60 to 300	55	0.02	17	
HOWF55-10	0.56	32	70 to 300	75	0.03	27	
HOWF75-10	0.83	43	80 to 400	75	0.03	40	
HOWF110-16	1.28	73	200 to 800	125	0.03	75	

Note 1) Conditions: Turbine oil Class 1 (ISO VG32), oil outlet temperature 50°C, water inlet temperature 30°C

Note 2) Increasing the cooling water flow volume to greater than the rated flow volume will increase the heat transfer and provide better cooling, but should be avoided as the increased flow speed within the pipe can cause corrosion.

Note 3) Use an oil-side flow rate within the range indicated above. (The product cannot be used with flow rates exceeding this range.)

How to Order

HOWF 7 - 06

Oil side port size

06	Rp (PS) 3/4
08	Rp (PS) 1
10	1 1/4 ^B flange
16	2 ^B flange

Basic size (Equivalent hydraulic motor kW)

7	7.5
11	11
22	22
37	37
55	55
75	75
110	110

Conditions In case of 55% heat loss of hydraulic motor kW
 Oil outlet temperature 50°C
 Water inlet temperature 30°C
 Turbine oil Class 1 (ISO VG32)

Model Selection

To select the appropriate model for your application, use the data at right and follow the steps below.

Item	Fluid cooled	Cooling water
Type (brand)	Turbine oil Class 1 (VG56)	—
Flow rate	130 L/min	(40) L/min
Temperature	Inlet	25°C
	Outlet	50°C
Heat exchange volume	15 kW	

Step (A): No Cooling Water Flow Rate Specified

- ① From Data (A), calculate the oil type–heat volume correction coefficient.
— Example: A = 0.97
- ② From Data (B), calculate the water temperature–heat volume correction coefficient.
— Example: B = 1.3
- ③ Using the correction coefficients obtained in ① and ②, calculate the converted heat exchange volume.
— Example: $Q = \frac{15}{0.97 \times 1.3} = 11.9 \text{ kW}$
- ④ Select the appropriate model from the model performance graph.
— Example: Oil outlet temperature 50°C, selected model **HOWF22**
In this case, the oil pressure drop can be calculated as follows.
- ⑤ From the model performance graph, determine the oil pressure drop.
— Example: $\Delta P = 0.04 \text{ MPa}$
- ⑥ From Data (D), calculate the oil type–pressure drop correction coefficient.
— Example: D = 1.4
- ⑦ Using ⑤ and ⑥, calculate the corrected oil pressure drop.
— Example: $\Delta P = 0.04 \times 1.4 = 0.056 \text{ MPa}$

(Result) Model: HOWF22, Oil pressure drop: $\Delta P = 0.056 \text{ MPa}$,
Cooling water volume: 55 L/min

Step (B): Cooling Water Flow Rate Specified

- ① From Data (A), calculate the oil type–heat volume correction coefficient.
— Example: A = 0.97
- ② From Data (B), calculate the water temperature–heat volume correction coefficient.
— Example: B = 1.3
- ③ From the model performance graph, locate the intersection of the oil flow rate and heat exchange volume lines to make a provisional model selection. Note that the rated water volume for the selected model can be determined from the specifications.
— Oil outlet temperature 50°C, provisional model selection HOWF37, rated water volume 55 L/min.
- ④ Divide the actual water volume by the rated water volume from ③. If the calculated water volume is 1 or greater, treat it as 1.
— Example: $\frac{40}{55} = 0.72$
- ⑤ From Data (C), calculate the water volume–heat volume correction coefficient.
— Example: C = 0.85
- ⑥ Using the correction coefficients obtained in ①, ②, and ⑤, calculate the converted heat exchange volume.
— Example: $Q = \frac{15}{0.97 \times 1.3 \times 0.85} = 14 \text{ kW}$
- ⑦ Select the appropriate model from the model performance graph.
— Example: Oil outlet temperature 50°C, selected model **HOWF37**
In this case, the oil pressure drop can be calculated as follows.
- ⑧ From the model performance graph, calculate the oil pressure drop.
— Example: $\Delta P = 0.035 \text{ MPa}$
- ⑨ From Data (D), calculate the oil type–pressure drop correction coefficient.
— Example: D = 1.4
- ⑩ Using ⑧ and ⑨, calculate the corrected oil pressure drop.
— Example: $\Delta P = 0.035 \times 1.4 = 0.049 \text{ MPa}$

(Result) Model: HOWF37, Oil pressure drop: $\Delta P = 0.049 \text{ MPa}$,
Cooling water volume: 40 L/min

Model Performance Graph ①: Oil Outlet Temperature 40°C

Conditions Oil outlet temperature: 40°C
Water inlet temperature: 30°C
Fluid: Turbine oil Class 1 (ISO VG32)
Oil side pressure drop: 0.01, 0.03, 0.05, 0.1 MPa indicated

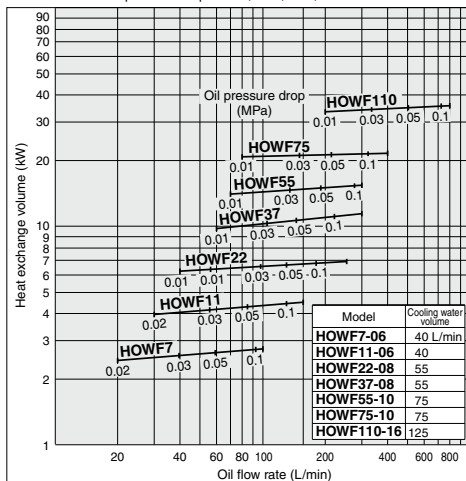

Model performance values include an allowance (approx. 25%) for water deposits.

Data (A) (Oil type/Heat volume correction coefficient)

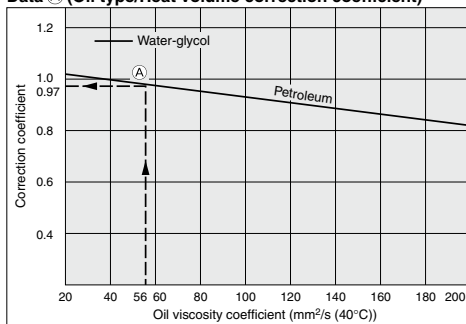

Data (B) (Water temperature/Heat volume correction coefficient)

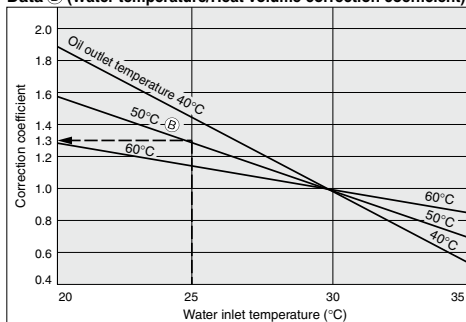

HOWF Series

Model Performance Graph ②: Oil Outlet Temperature 50°C

Conditions Oil outlet temperature: 50°C
 Water inlet temperature: 30°C
 Fluid: Turbine oil Class 1 (ISO VG32)
 Oil side pressure drop: 0.01, 0.03, 0.05, 0.1 MPa indicated

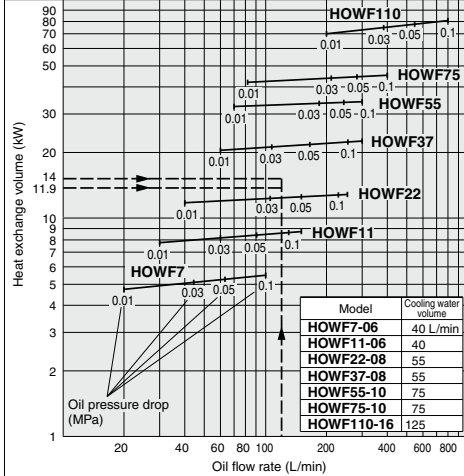

Model performance values include an allowance (approx. 25%) for water deposits.

Model Performance Graph ③: Oil Outlet Temperature 60°C

Conditions Oil outlet temperature: 60°C
 Water inlet temperature: 30°C
 Fluid: Turbine oil Class 1 (ISO VG32)
 Oil side pressure drop: 0.01, 0.03, 0.05, 0.1 MPa indicated

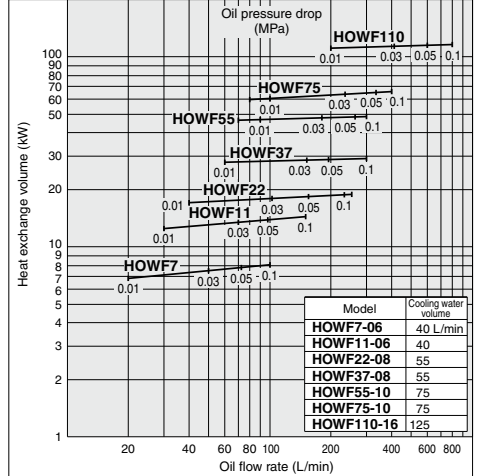

Model performance values include an allowance (approx. 25%) for water deposits.

Data ③ (Water volume/Heat volume correction coefficient)

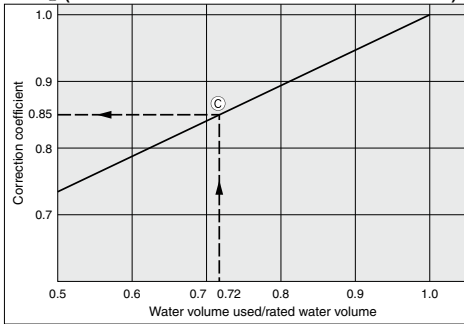

Data ④ (Oil type/Pressure drop correction coefficient)

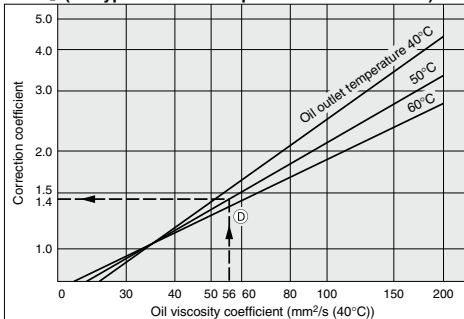
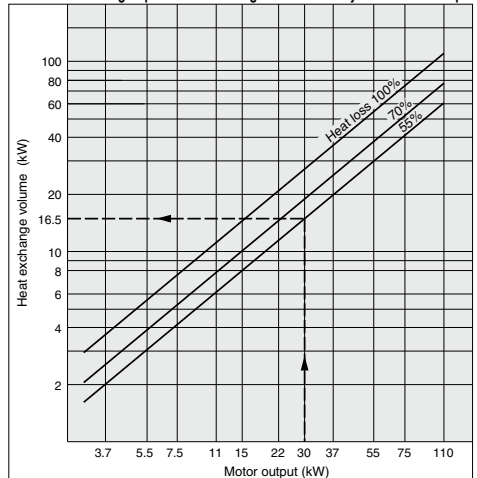
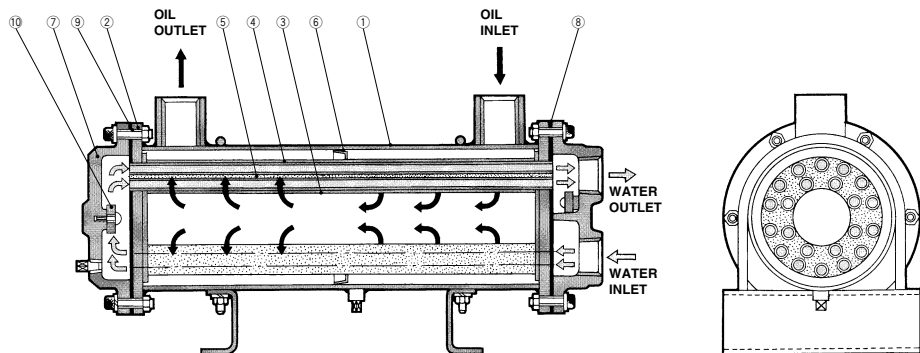

Table for calculating required heat exchange volume from hydraulic motor output



Note) If the hydraulic pump motor output is 30 kW and the heat loss is 55%, the required conversion volume is 16.5 kW. (Select the heat loss percentage based on the hydraulic circuit.)

Construction/Component Parts



The HOWF series employs a multi-pipe design with the heat transfer pipes arranged in a circular pattern. The area between the pipes is filled with porous metal particles. Cooling water flows through the heat transfer pipes. Fluid flows in through the inlet on the side of the cooler and passes among the metal particles outside the heat transfer pipes, finally reaching the open cavity in the center. It then flows axially through the center cavity, once again passes among the metal particles, and flows out through the outlet.

The cooling water inlet and outlet can be reversed. However, the oil inlet and outlet cannot be reversed, and the cooling water and oil flow paths cannot be switched.

Component Part Materials

No.	Description	Material	Note
①	Body	STK	
②	Pipe plate A	SS400	
③	Metal particle cover	Stainless steel 304	
④	Heat transfer pipe	C1220T	
⑤	Metal particles	SS	Copper-plated
⑥	Baffle	Stainless steel 304	
⑦	Water chamber cover	FC200	

Component Parts

Model	No. Description Material Quantity	⑧	⑨	⑩
		Gasket A NBR	Gasket B NBR	Corrosion-resistant zinc Zn
HOWF7-06				
HOWF11-06		P1751411	P1751412	
HOWF22-08		P1751611	P1751612	P1751427
HOWF37-08				
HOWF55-10		P1751810	P1751811	
HOWF75-10				
HOWF110-16		P175126	P175127	P175067



HOWF Series

Dimensions

HOWF7-06 to HOWF75-10

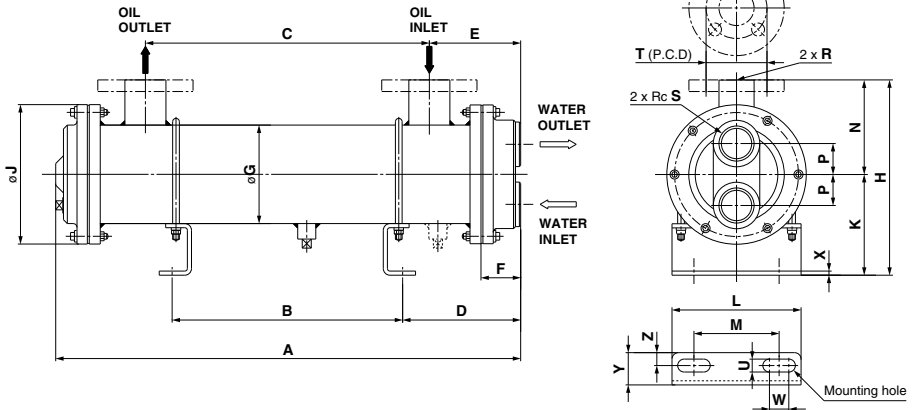

HOWF110-16

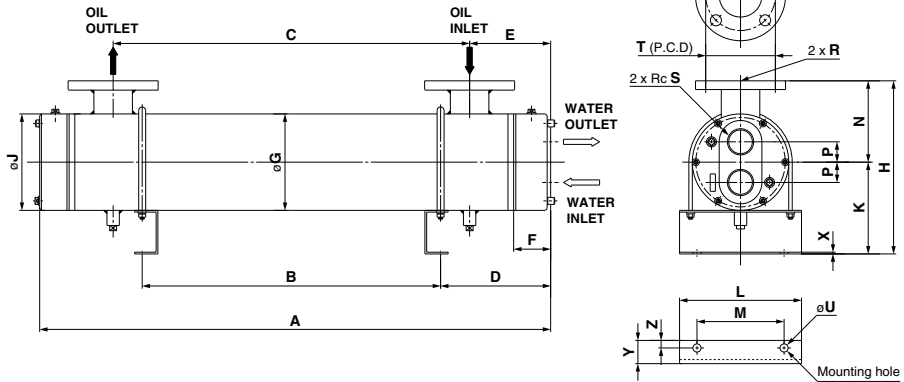

Model	A	B	C	D	E	F	øG	H	øJ	K	L	M	N	P	R	S
HOWF7-06	246	60	105	93	72	30	76	151	108	78	100	66	73	24	Rp (PS) 3/4	3/4
HOWF11-06	361	175	220	95	72	30	76	151	108	78	100	66	73	24	Rp (PS) 3/4	3/4
HOWF22-08	429	210	270	113	83	33	89	169	121	84	113	79	85	28	Rp (PS) 1	1
HOWF37-08	639	420	480	113	83	33	89	169	121	84	113	79	85	28	Rp (PS) 1	1
HOWF55-10	742	500	570	125	90	35	114	229	146	107	143	103	122	34	1 1/4 ^B flange	1 1/4
HOWF75-10	1057	815	885	125	90	35	114	229	146	107	143	103	122	34	1 1/4 ^B flange	1 1/4
HOWF110-16	1313	950	1050	189	139	64	165	298	166	158	210	150	140	35	2 ^B flange	1 1/2

Model	T	U	W	X	Y	Z
HOWF7-06	—	10	15	3.2	25	10
HOWF11-06	—	10	15	3.2	25	10
HOWF22-08	—	10	15	3.2	25	10
HOWF37-08	—	10	15	3.2	25	10
HOWF55-10	100	12	13	3.2	30	12
HOWF75-10	100	12	13	3.2	30	12
HOWF110-16	120	ø14	—	7	40	13

Note) Threads conform to JIS B 0203 parallel female thread (oil side) and tapered female thread (water side). Flanges conform to JIS B 2220 (JIS 10K FF). B dimensions are maximum values. The HOWF7-06 only is equipped with a fluid drain plug directly below the OIL INLET. Since foot and U-bolts are not pre-mounted, they should be mounted during installation.