

# Compact Vacuum Ejector

Series **ZA**

**Total length**  
**72.9 mm**

**Total width**  
**9.9 mm**

**Total height**  
**52.5 mm**

**Weight** **50 g**

Possible to be mounted on moving parts thanks to lightweight

**Response time**  
**40 ms**

Response time for up to  $-60$  kPa  
Nozzle diameter:  $\phi 0.7$   
Piping:  $\phi 4/\phi 2.5 \times 100$  mm

**Able to install on the moving parts**

Shortened tube length to pad makes the response time improved.

- **Supply pilot valve**
  - Normally closed
  - Latching
- **Release valve**
  - Normally closed
- **Available with or without pressure sensor**

2 kinds of pressure range are selectable.

  - 0 to  $-101$  kPa
  - $-100$  to  $100$  kPa
- **Suction filter**
  - Nominal filtration rating:  $30 \mu\text{m}$

# Compact Vacuum Ejector Series ZA

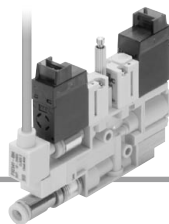

## How to Order

### Ejector Unit

ZA1 07 1 - K1 5 L - P1 - 0 1

#### Nozzle nominal size

|    |     |
|----|-----|
| 05 | 0.5 |
| 07 | 0.7 |

#### Solenoid valve combination (Refer to Table (1).)

| Symbol | Supply pilot valve       | Release valve   |
|--------|--------------------------|-----------------|
| K1     | Normally closed          | Normally closed |
| J1     | Normally closed          | None            |
| Q1     | Latching positive common | Normally closed |
| Q2     | Latching positive common | None            |
| N1     | Latching negative common | Normally closed |
| N2     | Latching negative common | None            |

#### Pilot valve (Refer to Table (1).)

|     |   |
|-----|---|
| Nil | Standard (1 W for DC) <sup>Note</sup>       |
| Y   | DC low wattage type (0.5 W) <sup>Note</sup> |

Note) Avoid energizing the solenoid valve for long periods of time. (Refer to Design and Selection on Specific Product Precautions 1.)

#### Power supply voltage (Refer to Table (1).)

|   |                    |
|---|--------------------|
| 1 | 100 VAC (50/60 Hz) |
| 2 | 200 VAC (50/60 Hz) |
| 3 | 110 VAC (50/60 Hz) |
| 4 | 220 VAC (50/60 Hz) |
| 5 | 24 VDC             |
| 6 | 12 VDC             |

#### Electrical entry

|    |   |  |
|----|---|--|
| L  | L plug connector, with 0.3 m lead wire, with light/surge voltage suppressor |  |
| LO | L plug connector, without connector, with light/surge voltage suppressor    |  |
| M  | M plug connector, with 0.3 m lead wire, with light/surge voltage suppressor |  |
| MO | M plug connector, without connector, with light/surge voltage suppressor    |  |
| G  | Grommet, with 0.3 m lead wire (Not available for latching and AC types.)    |  |

#### Vacuum (V) port

| Symbol | Applicable tubing O.D. |
|--------|------------------------|
| 1      | 3.2 (Straight)         |
| 2      | 4 (Straight)           |
| 4      | 3.2 (Elbow)            |
| 5      | 4 (Elbow)              |

#### Air pressure supply (P) port

| Symbol | Applicable tubing O.D.                                |
|--------|---|
| 0      | Without fitting (M3 x 0.5)                            |
| 2      | 4 (Straight)  |
| 5      | 4 (Elbow)   |
| M      | Without supply adapter <sup>Note</sup> (For manifold) |

Note) O-ring and round head combination screws AC00690 (M2 x 12) are attached to the supply adapter (M).

#### Pressure sensor specifications

| Symbol | Rated pressure range and accuracy                         | Part no. |
|--------|---|----------|
| P1     | With pressure sensor (0 to -101 kPa, accuracy ±2% F.S.)   | PSE541   |
| P1A    | With pressure sensor (0 to -101 kPa, accuracy ±1% F.S.)   | PSE541A  |
| P3     | With pressure sensor (-100 to 100 kPa, accuracy ±2% F.S.) | PSE543   |
| P3A    | With pressure sensor (-100 to 100 kPa, accuracy ±1% F.S.) | PSE543A  |
| B      | Without pressure sensor <sup>Note 1</sup>                 | KQ2P-04  |

Note 1) One-touch fittings are plugged when the pressure sensor is mounted.

Note 2) This pressure switch detects pressure and converts the data into analog output.

When the product is used as a vacuum switch, a pressure sensor controller Series PSE300 (CAT. ES100-56) is necessary.

#### Suction filter

|     |                        |
|-----|------------------------|
| Nil | Without suction filter |
| F   | With suction filter    |

#### Manual override

|     |  |
|-----|--|
| Nil | Non-locking push type (Tool required)            |
|     | Latching type: Push-locking type (Tool required) |
| B   | Locking type (Tool required)                     |

Note) Latching type (supply valve) has the push-locking type only, but either the push type or the locking type can be selected for the release valve.

Table (1) Combination of Solenoid Valve, Pilot Valve and Power Supply Voltage

| Combination no. | Solenoid valve combination symbol | Pilot valve symbol | Applicable power supply voltage (V) |             |             |             |            |            |
|-----------------|-----------------------------------|--------------------|-------------------------------------|-------------|-------------|-------------|------------|------------|
|                 |                                   |                    | 1<br>100 AC                         | 2<br>200 AC | 3<br>110 AC | 4<br>220 AC | 5<br>24 DC | 6<br>12 DC |
| ①               | K1                                | Nil                | —                                   | —           | —           | —           | ●          | ●          |
| ②               | K1                                | Y                  | —                                   | —           | —           | —           | ●          | ●          |
| ③               | J1                                | Nil                | ●                                   | ●           | ●           | ●           | ●          | ●          |
| ④               | J1                                | Y                  | —                                   | —           | —           | —           | ●          | ●          |
| ⑤               | Q1                                | Nil                | —                                   | —           | —           | —           | ●          | ●          |
| ⑥               | Q2                                | Nil                | ●                                   | ●           | ●           | ●           | ●          | ●          |
| ⑦               | N1                                | Nil                | —                                   | —           | —           | —           | ●          | ●          |
| ⑧               | N2                                | Nil                | —                                   | —           | —           | —           | ●          | ●          |

\* Combinations (1) to (8) in the above table are the only possible options.

## Warning

The filter case of this suction filter is made of polycarbonate. Do not use it with or expose it to the following chemicals: paint thinner, carbon tetrachloride, chloroform, acetate ester, aniline, cyclohexane, trichloroethylene, sulfuric acid, lactic acid, water-soluble cutting oil (alkaline), etc. Also, do not expose it to direct sunlight. This suction filter is exclusive to Series ZA. Do not use for other purposes.

## How to Order

**Manifold**

**ZZA1 08 - 3 P**

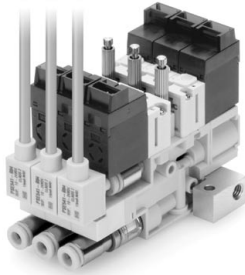

Number of stations

|    |            |
|----|------------|
| 01 | 1 station  |
| 02 | 2 stations |
| ⋮  | ⋮          |
| 08 | 8 stations |

• Right common air pressure supply (P) port (viewed from the vacuum (V) port side)

| Symbol | Applicable tubing O.D.     |
|--------|----------------------------|
| 0      | Without fitting (M5 x 0.8) |
| 2      | 4 (Straight)               |
| 3      | 6 (Straight)               |
| 5      | 4 (Elbow)                  |
| 6      | 6 (Elbow)                  |
| P      | With plug                  |

• Left common air pressure supply (P) port (viewed from the vacuum (V) port side)

| Symbol | Applicable tubing O.D.     |
|--------|----------------------------|
| 0      | Without fitting (M5 x 0.8) |
| 2      | 4 (Straight)               |
| 3      | 6 (Straight)               |
| 5      | 4 (Elbow)                  |
| 6      | 6 (Elbow)                  |
| P      | With plug                  |

### Maximum Simultaneous Operating Stations

| Manifold model           | Ejector nozzle diameter |            |
|--------------------------|-------------------------|------------|
|                          | ø0.5                    | ø0.7       |
| ZZA1 Stations -2P<br>-5P | 4 stations              | 2 stations |
| ZZA1 Stations -22<br>-55 | 8 stations              | 4 stations |
| ZZA1 Stations -3P        | 8 stations              | 4 stations |
| ZZA1 Stations -6P        | 6 stations              | 3 stations |
| ZZA1 Stations -33        | 8 stations              | 8 stations |
| ZZA1 Stations -66        | 8 stations              | 6 stations |

### Manifold Ordering Example

- ZZA108-2P → 1 pc.
- \*ZA1071-K15L-FP1-M2 → 4 pcs. (Stations 1 to 4)
- \*ZA1051-Q15L-FB-M1 → 3 pcs. (Stations 5 to 7)
- \*ZA1-BP1 → 1 pc. (Station 8)

Blanking plate assembly

Note) The stations are sequentially numbered. When viewed from the side of the vacuum ports, the far left station is designated as station 1.

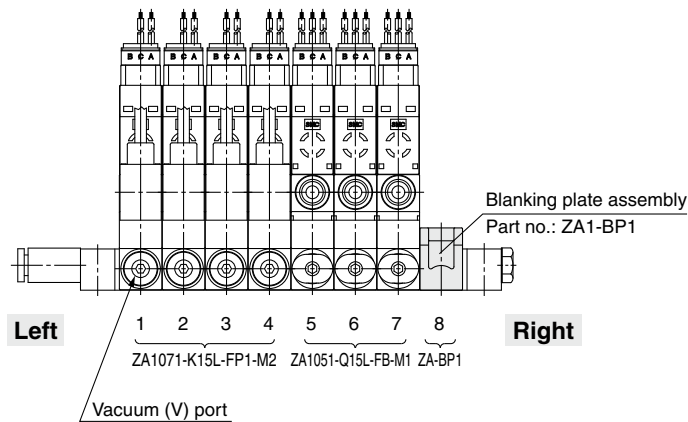

### Flow / Exhaust Characteristics (Representative values)

#### ZA05 Exhaust Characteristics

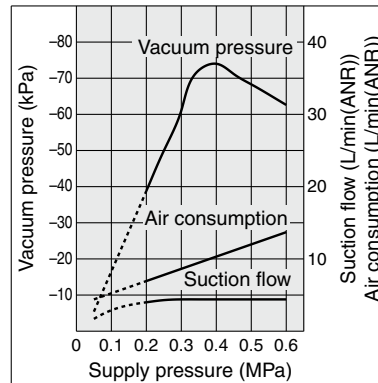

#### ZA05 Flow Characteristics

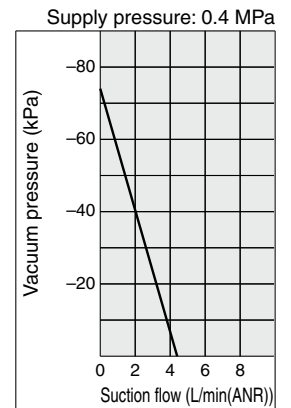

#### ZA07 Exhaust Characteristics

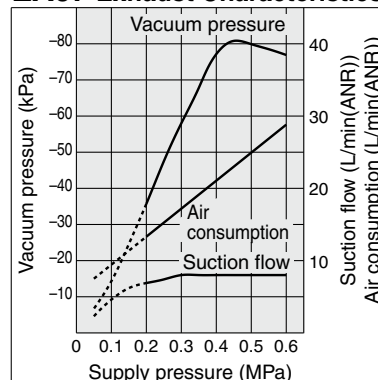

#### ZA07 Flow Characteristics

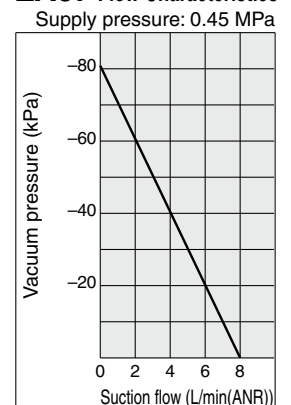

## Specifications

### General Specifications

|                                       |                             |
|---------------------------------------|-----------------------------|
| Maximum operating pressure            | 0.50 MPa                    |
| Minimum operating pressure            | 0.20 MPa                    |
| Operating temperature range           | 5 to 50°C (No condensation) |
| Fluid                                 | Air                         |
| Vibration resistance <sup>Note)</sup> | 30 m/s <sup>2</sup>         |

Note) There was no malfunction confirmed when tested under the following conditions: From 10 to 500 to 10 Hz and whichever of the following is smaller: 1.5 mm amplitude or 98 m/s<sup>2</sup> acceleration in X, Y, Z direction for 2 hours each. (initial value)

### Ejector

|   |                |                |
|---|----------------|----------------|
| Nozzle nominal diameter                   | 0.5 mm         | 0.7 mm         |
| Standard supply pressure <sup>Note)</sup> | 0.40 MPa       | 0.45 MPa       |
| Maximum vacuum pressure <sup>Note)</sup>  | -74 kPa        | -78 kPa        |
| Maximum suction flow                      | 4 L/min (ANR)  | 8 L/min (ANR)  |
| Air consumption                           | 12 L/min (ANR) | 28 L/min (ANR) |

Note) The maximum vacuum pressure was determined by applying the standard supply pressure. Different supply pressures are required to determine a model.

### Pressure Sensor

| Model                               | PSE541  | PSE541A                                   | PSE543                                    | PSE543A                                   |
|-------------------------------------|---|---|---|---|
| Rated pressure range                | 0 to -101 kPa   |   | -100 to 100 kPa                           |   |
| Proof pressure                      | 500 kPa   |   |   |   |
| Fluid                               | Air   |   |   |   |
| Output voltage                      | Analog output 1 to 5 V (within rated pressure range), 0.6 to 1 V (within extension analog output range)                           |   |   |   |
| Output impedance                    | Approx. 1 kΩ  |   |   |   |
| Power supply                        | 12 to 24 VDC ±10%, Ripple (p-p) 10% or less (with power supply polarity protection)   |   |   |   |
| Current consumption                 | 15 mA or less   |   |   |   |
| Accuracy (Ambient temperature 25°C) | ±2% F.S.<br>(within rated pressure range)   | ±1% F.S.<br>(within rated pressure range) | ±2% F.S.<br>(within rated pressure range) | ±1% F.S.<br>(within rated pressure range) |
| Linearity                           | ±0.4% F.S.  |   |   |   |
| Repeatability                       | ±0.2% F.S.<br>Effects to the output value due to supply voltage: ±0.8% F.S.   |   |   |   |
| Temperature characteristics         | ±2% F.S. (based on 25°C)  |   |   |   |
| Operating humidity range            | Operating/Stored: 35 to 85% RH (No condensation)  |   |   |   |
| Withstand voltage                   | 1000 VAC or more, 50/60 Hz for 1 minute between terminals and housing   |   |   |   |
| Insulation resistance               | 50 MΩ or more (500 VDC measured via megohmmeter) between terminals and housing  |   |   |   |
| Sensor cable                        | Oilproof heavy-duty vinyl cable (ellipse), 3 cores, 2.7 x 3.2, 3 m, Conductor area: 0.15 mm <sup>2</sup> , Insulator O.D.: 0.9 mm |   |   |   |

### Weight

| Single unit             |      |
|-------------------------|------|
| With pressure sensor    | 50 g |
| Without pressure sensor | 45 g |
| Manifold base           |      |
| 1 station               | 9 g  |
| 2 stations              | 11 g |
| 3 stations              | 13 g |
| 4 stations              | 15 g |
| 5 stations              | 17 g |
| 6 stations              | 19 g |
| 7 stations              | 21 g |
| 8 stations              | 23 g |

● Calculation of weight for the manifold type  
(Single unit weight) x (Number of stations)  
+ (Manifold base)

Example) 5 stations manifold with pressure sensors

$$50 \text{ (g)} \times 5 + 17 \text{ (g)} = 267 \text{ (g)}$$

## Construction

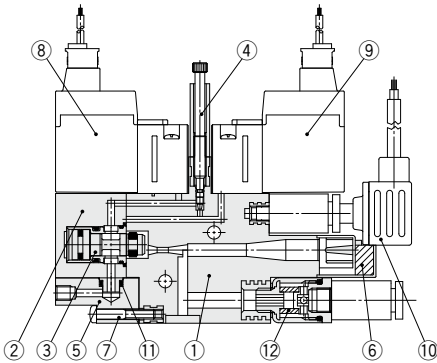

### Component Parts

| No. | Description                            | Material |
|-----|--|----------|
| 1   | Body                                   | PBT      |
| 2   | Valve cover                            | PBT      |
| 3   | Poppet valve assembly                  |          |
| 4   | Release flow adjusting needle assembly |          |
| 5   | Supply adapter                         |          |

### Replacement Parts

| No. | Description                  | Part no.          |
|-----|------------------------------|-------------------|
| 6   | Sound absorbing material     | ZA1-SAE2          |
| 7*  | Round head combination screw | AC00690 (M2 x 12) |
| 8   | Supply pilot valve           | VQ110□-□□□        |
| 9   | Release valve                | VQ110□-□□□        |
| 10  | Pressure sensor              | PSE54□-R04        |
| 11* | O-ring                       | KA00177           |
| 12  | Filter element               | ZA1-FE-30         |

\* For above parts of No. 7 and No. 11, the parts assembly ZA1-OP-1 (10 pcs each) is available.

## How to Order

### Solenoid Valve

VQ110□ - 5 L □

Pilot valve

|     |  |
|-----|--|
| Nil | Standard (1 W)   |
| Y   | Low wattage type (0.5 W)<br>* Not applicable to AC type. |
| L   | Latching positive common                                 |
| N   | Latching negative common                                 |

Solenoid valve connector assembly part no.

Manual override

|     |   |
|-----|---|
| Nil | Non-locking push type<br>(Tool required)            |
|     | Latching type: Push-locking type<br>(Tool required) |
| B   | Locking type (Tool required)                        |

(Note) Latching manual override:  
Push-locking type only

### How to order connector assembly

DC

• Single

AXT661-14A-□

DC positive common

• Latching

AXT661-13A-□

DC negative common

• Latching

AXT661-13AN-□

100 VAC

• Single

AXT661-31A-□

• Latching

AXT661-32A-□

200 VAC

• Single

AXT661-34A-□

• Latching

AXT661-35A-□

Connector, socket (3 pcs) only

AXT661-12A

Lead wire length

|     |         |
|-----|---------|
| Nil | 300 mm  |
| 6   | 600 mm  |
| 10  | 1000 mm |
| 20  | 2000 mm |
| 30  | 3000 mm |

### Lead-wire length of the plug connector

The lead-wire length for a valve with a lead-wire is 300 mm. When in need of a valve with a lead-wire longer than 600 mm, place an order for a valve without a connector and connector assembly.

### Rated coil voltage

|   |         |
|---|---------|
| 1 | 100 VAC |
| 2 | 200 VAC |
| 3 | 110 VAC |
| 4 | 220 VAC |
| 5 | 24 VDC  |
| 6 | 12 VDC  |

### Electrical entry

|    |   |  |
|----|---|--|
| L  | L plug connector, with 0.3 m lead wire                                      |  |
| LO | L plug connector, without connector, with light/surge voltage suppressor    |  |
| M  | M plug connector, with 0.3 m lead wire                                      |  |
| MO | M plug connector, without connector, with light/surge voltage suppressor    |  |
| G  | Grommet, with 0.3 m lead wire<br>(Not available for latching and AC types.) |  |

### Pressure Sensor

PSE54 1 □ - R04

Rated pressure range

|   |                 |
|---|-----------------|
| 1 | 0 to -101 kPa   |
| 3 | -100 to 100 kPa |

Accuracy

|     |                  |
|-----|------------------|
| Nil | ±2% F.S. or less |
| A   | ±1% F.S. or less |

For details on the PSE54□ series, [click here](#).

# Series ZA

## Dimensions

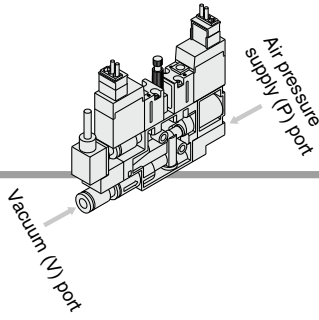

### Type K1

ZA1 □ □ 1-K1 □ □ □ □ - □ □ □ □ - □ □

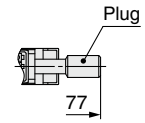
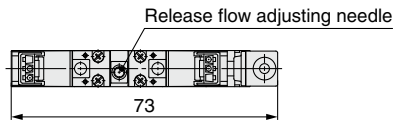

ZA1 □ □ 1-K1 □ □ □ □ - □ B - □ □

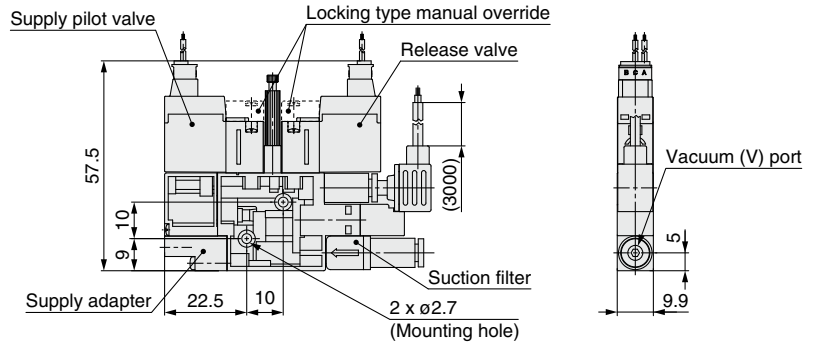
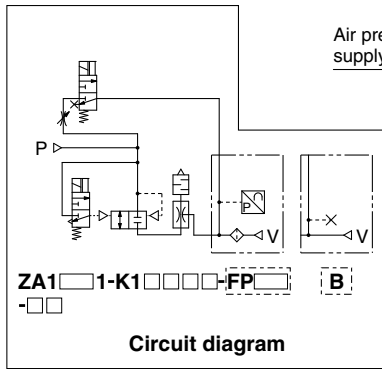

ZA1 □ □ 1-K1 □ □ L □ - FP □ □ - 02

Note) When the body is mounted, tighten with a torque of  $0.6 \pm 0.06$  N·m. Using excessive torque may cause damage to the body.

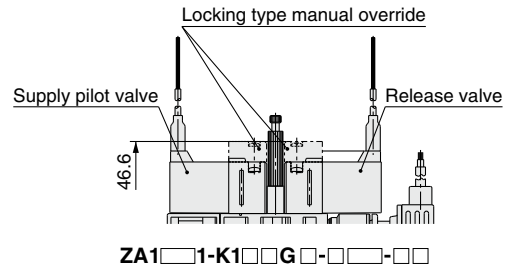
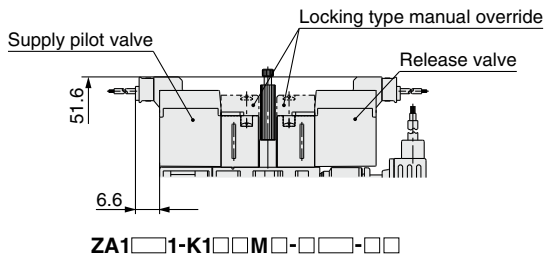

## Dimensions of the vacuum (V) and air pressure supply (P) port fittings after installation

Dimensions after the fittings are installed on the vacuum (V) port, and air pressure supply (P) port of a single unit are shown below.

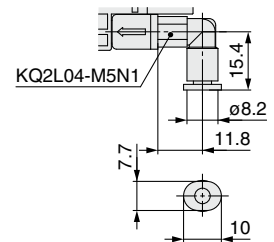
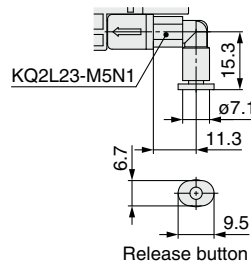
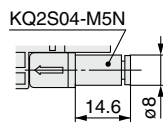
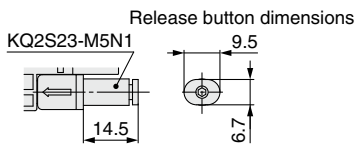

ZA1 □ □ 1-K1 □ □ □ □ - □ □ □ □ - 01

ZA1 □ □ 1-K1 □ □ □ □ - □ □ □ □ - 02

ZA1 □ □ 1-K1 □ □ □ □ - □ □ □ □ - 04

ZA1 □ □ 1-K1 □ □ □ □ - □ □ □ □ - 05

## Dimensions of the vacuum (V) port fittings after installation

Release button dimensions

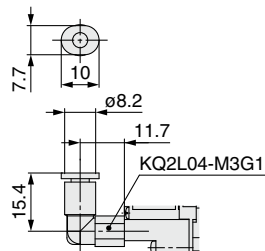

ZA1 □ □ 1-K1 □ □ □ □ - □ □ □ □ - 5 □

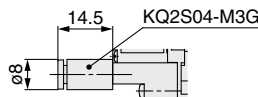

ZA1 □ □ 1-K1 □ □ □ □ - □ □ □ □ - 2 □

## Dimensions of the air pressure supply (P) port fittings after installation

## Dimensions

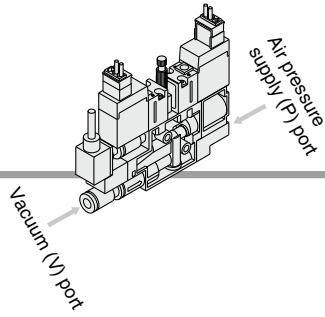

### Type J1

ZA1 □ 1-J1 □ □ □ □ - □ □ □ □

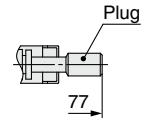
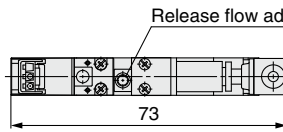

ZA1 □ 1-J1 □ □ □ □ - □ B-□ □

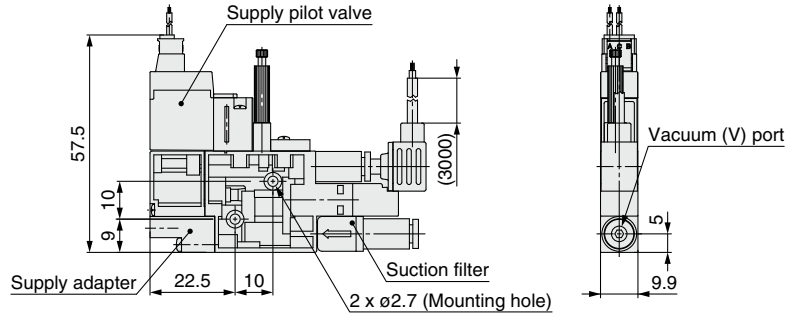
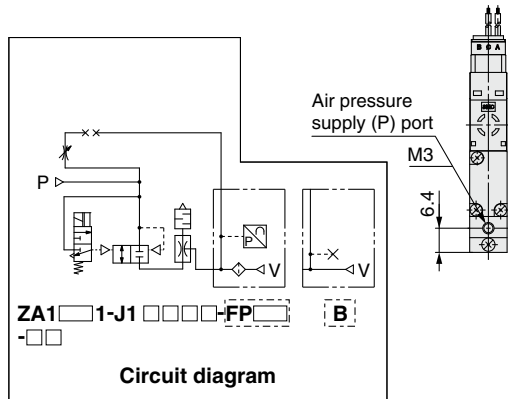

Note) When the body is mounted, tighten with a torque of  $0.6 \pm 0.06$  N·m. Using excessive torque may cause damage to the body.

ZA1 □ 1-J1 □ □ L □ -FP □ □ -02

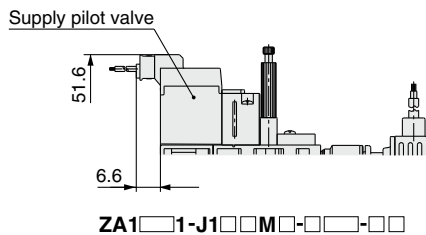

ZA1 □ 1-J1 □ □ M □ - □ □ □ □

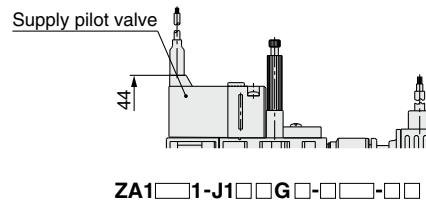

ZA1 □ 1-J1 □ □ G □ - □ □ □ □

## Dimensions of the vacuum (V) and air pressure supply (P) port fittings after installation

Dimensions after the fittings are installed on the vacuum (V) port, and air pressure supply (P) port of a single unit are shown below.

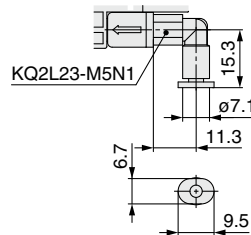
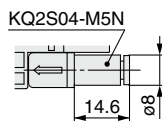
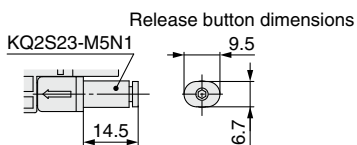

Release button dimensions

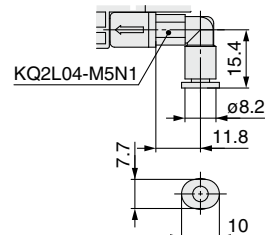

Release button dimensions

ZA1 □ 1-J1 □ □ □ □ - □ □ -01

ZA1 □ 1-J1 □ □ □ □ - □ □ -02

ZA1 □ 1-J1 □ □ □ □ - □ □ -04

ZA1 □ 1-J1 □ □ □ □ - □ □ -05

### Dimensions of the vacuum (V) port fittings after installation

Release button dimensions

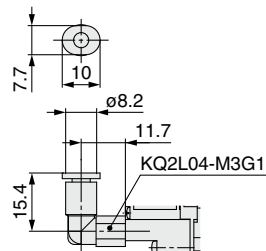

ZA1 □ 1-J1 □ □ □ □ - □ □ -5 □

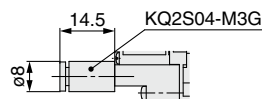

ZA1 □ 1-J1 □ □ □ □ - □ □ -2 □

### Dimensions of the air pressure supply (P) port fittings after installation





## Dimensions

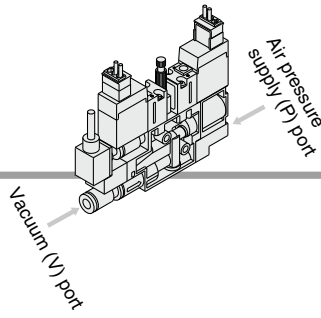

Type  $\begin{matrix} Q2 \\ N2 \end{matrix}$   
**ZA1**  1- $\begin{matrix} Q2 \\ N2 \end{matrix}$

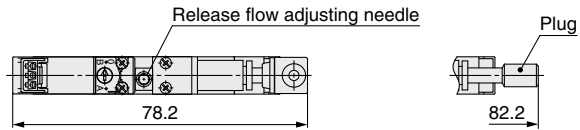

**ZA1**  1- $\begin{matrix} Q2 \\ N2 \end{matrix}$       **B**-

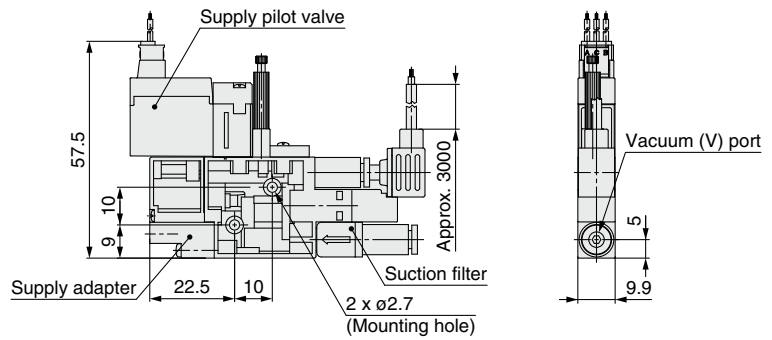
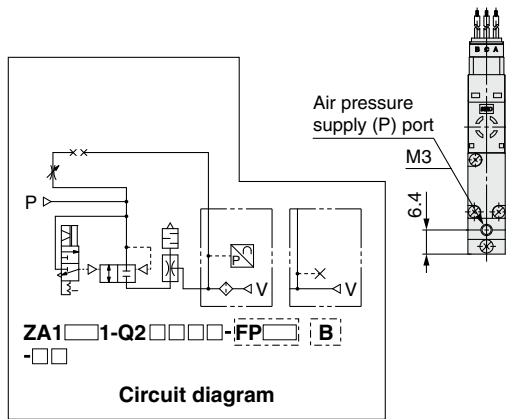

**ZA1**  1- $\begin{matrix} Q2 \\ N2 \end{matrix}$   **L**  **FP**   **02**

Note) When the body is mounted, tighten with a torque of  $0.6 \pm 0.06$  N·m. Using excessive torque may cause damage to the body.

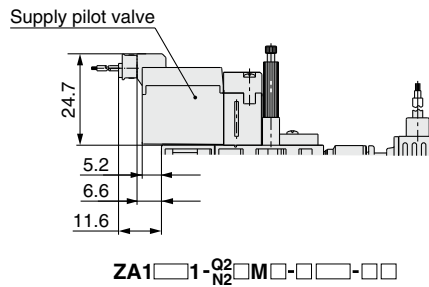

**ZA1**  1- $\begin{matrix} Q2 \\ N2 \end{matrix}$   **M**

## Dimensions of the vacuum (V) and air pressure supply (P) port fittings after installation

Dimensions after the fittings are installed on the vacuum (V) port, and air pressure supply (P) port of a single unit are shown below.

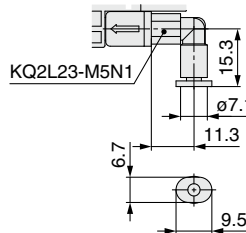
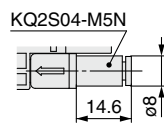
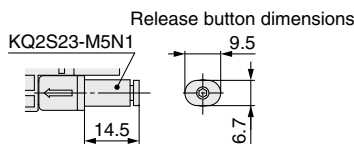

Release button dimensions

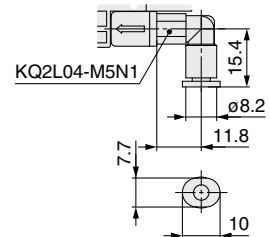

Release button dimensions

**ZA1**  1- $\begin{matrix} Q2 \\ N2 \end{matrix}$         **01**

**ZA1**  1- $\begin{matrix} Q2 \\ N2 \end{matrix}$         **02**

**ZA1**  1- $\begin{matrix} Q2 \\ N2 \end{matrix}$         **04**

**ZA1**  1- $\begin{matrix} Q2 \\ N2 \end{matrix}$         **05**

## Dimensions of the vacuum (V) port fittings after installation

Release button dimensions

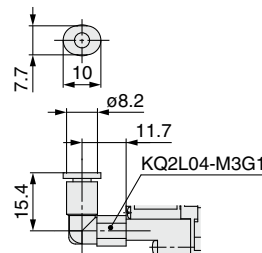

**ZA1**  1- $\begin{matrix} Q2 \\ N2 \end{matrix}$         **05**

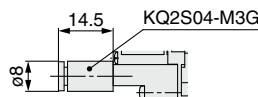

**ZA1**  1- $\begin{matrix} Q2 \\ N2 \end{matrix}$         **02**

## Dimensions of the air pressure supply (P) port fittings after installation



**Manifold Type: How to Increase / Decrease Manifold Stations**

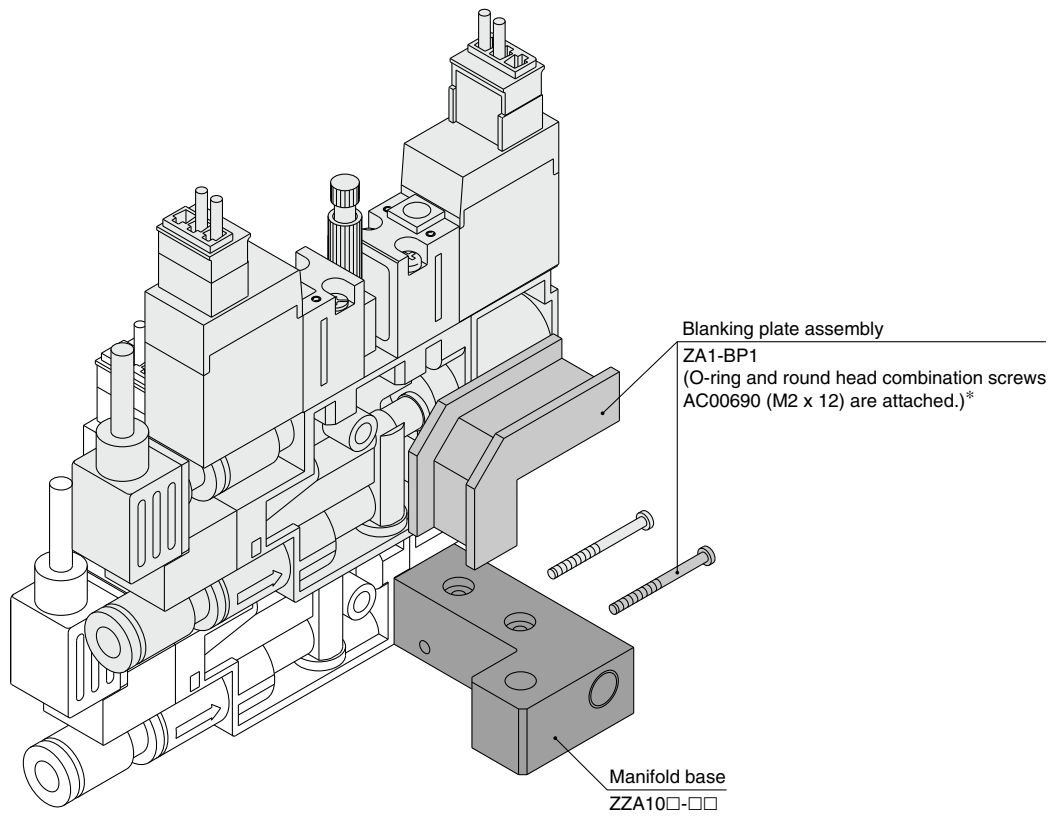

\* An assembly kit (part no. ZA1-OP-1) is available which includes 10 pcs each of O-rings and round head combination screws.



# Series ZA Specific Product Precautions 1

Be sure to read before handling. Refer to Best Pneumatics No. 4 for Safety Instructions and Vacuum Equipment Precautions.

## Design and Selection

### Warning

#### 1. Avoid energizing the solenoid valve for long periods of time.

If a solenoid valve is energized for a long period of time, the coil will get hot and the performance may be reduced. Additionally, the peripheral equipment in close proximity may also be badly affected. Use a low wattage solenoid valve when the solenoid valve is energized continuously or when the duration of the energization is longer than the non-energized period each day. Periods of energization can be shortened by using a latching type solenoid valve. But, do not energize the coil on both A and B sides simultaneously when using the latching type.

Continuous energization of the solenoid valve should be less than 10 minutes in duration and the energization period should be shorter than the non-energized period. Take measures for any heat radiation so that the temperature is within the range of solenoid valve specifications when the solenoid valve is mounted on the control panel. Please pay special attention to any temperature increases when a manifold type with 3 stations or more is energized continuously or when three individual units are placed in close proximity.

#### 2. Use the vacuum equipment within the operating supply pressure range.

When the operating with a lower supply pressure, the vacuum performance will be reduced and the poppet valve will cause malfunction.

Never use the vacuum equipment more than the operating supply pressure range as this may cause damage to the product resulting in potentially dangerous operation.

#### 3. Suspension of operation for long periods of time

Please use caution — as detailed below — when the vacuum equipment is turned off for periods in excess of 6 hours.

- Be sure to turn off the pressure supply to the vacuum equipment.

Please observe this precautions as the supply pressure will be applied for a extra period of time due to the line pressure increase and may result in damage to the vacuum equipment.

- Be sure to turn off the power supply to the solenoid valve and the pressure switch.

Please observe this precautions as any heat generated due to the length of energization time may seriously affect the vacuum equipment and peripheral equipment resulting in potentially dangerous operation.

#### 4. Exhaust port (EXH port) on the vacuum ejector

Please check the exhaust port (EXH port) on the vacuum ejector, so that any exhaust resistance will not be increased due to insulating materials or restrictions in the piping. The exhaust resistance may reduce the ejector's performance. Additionally, never use this product in an application where the exhaust port is blocked when detaching a workpiece. This misuse may result in possible damage to the product.

#### 5. Vacuum release flow adjusting needle

Adjust the vacuum release flow adjusting needle from the fully closed to the open state by 1/8 to 1/4 turns to detach a workpiece completely during the ON time of a release valve.

Do not supply compressed air while the vacuum release flow adjusting needle is adjusted. Securely lock it with a lock nut after adjustment.

### Warning

#### 6. How to use the latching type solenoid valve

Our Latching type solenoid are fitted with a self-detaining mechanism. Its construction features an armature inside the solenoid which is set or reset using spontaneous energization. (20 ms or greater) Therefore, continuous energization is not required.

### How to Use the Latching Type Plug Connector

#### Wiring specifications

- Wiring should be connected as shown below. Connect with the power supply respectively.

#### DC positive common

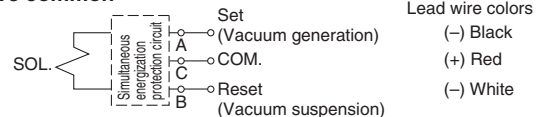

#### DC negative common

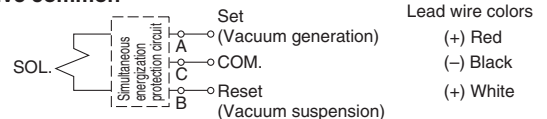

#### AC type

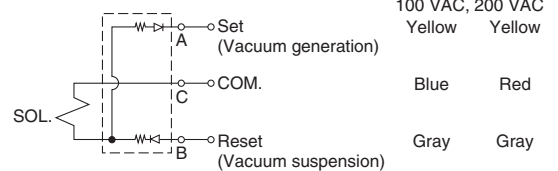

Special care must be taken for the latching type.

- Avoid using this product with a circuit which electrifies both the set and reset signals simultaneously.
- The minimum energization time required for self-detaining is 20 ms.
- Please contact us when using this product in locations where there are vibration levels of 30 m/s<sup>2</sup> or above or highly magnetic fields. No problems arise in normal usage or locations.
- This valve retains the reset position (Flow path: A → R) at the time of shipment. However, it may alter to the set position during transportation or due to vibration when mounting the valve. Therefore, confirm the home position either manually or with power supply prior to use.

#### 7. Suction filter

This suction filter is dedicated to the ZA series. Avoid using it for other purposes.



## Series ZA Specific Product Precautions 2

Be sure to read before handling. Refer to Best Pneumatics No. 4 for Safety Instructions and Vacuum Equipment Precautions.

### Mounting

#### Warning

1. **When the body is mounted, tighten with a torque of  $0.6 \pm 0.06$  N·m.**

Using excessive torque may cause damage to the body.

2. **When the filter assembly is mounted, tighten with a torque of  $0.07 \pm 0.01$  N·m.**

Using excessive torque may cause damage to the filter case.

### Operating Environment

#### Warning

1. **Suction filter**

The filter case of this suction filter is made of polycarbonate. Do not use it with or expose it to the following chemicals: paint thinner, carbon tetrachloride, chloroform, acetic ester, aniline, cyclohexane, trichloroethylene, sulfuric acid, lactic acid, water-soluble cutting oil (alkaline), etc. Also, do not expose it to direct sunlight.