



# Operation Manual

## PRODUCT NAME

*Common Supply Regulator*

## MODEL / Series / Product Number

**AR20M(K)-(F,N)(0101,0201,0202)(B,E,E1,E2,E3,E4,G,H,J,M)(-1,N,Y,Z,ZA)-D**

**AR30M(K)-(F,N)(0202,0302)(B,E,E1,E2,E3,E4,G,H,J,M)(-1,N,Y,Z,ZA)-D**

**AR40M(K)-(F,N)(0302,0303,0402,0403)(B,E,E1,E2,E3,E4,G,H,J,M)(-1,N,Y,Z,ZA)-D**

**SMC Corporation**

# Contents

	Page
1. Safety Instructions	2~6
2. Application	7
3. Standard Specifications	7
4. How to Order	8
5. Options	9
6. Structural Drawing and Replacement Parts	10
7. Assembly of Optional Parts	11
8. Operation and Adjustment	12-13
9. Trouble Shooting	14-15
10. How to Replace the Components	16-21
10-1. Diaphragm Assembly Replacement	16
10-2. Valve Guide Assembly and Valve Assembly Replacement	17
10-3. Square Embedded Type Pressure Gauge Replacement	18
10-4. Right Angle Square Type Pressure Gauge Replacement	19
10-5. Plug (with O-ring) Replacement	20
10-6. Plug Assembly Replacement	21
11. Disassembly Drawing	22-23
12. Dimensions	24



# Common Supply Regulator Safety Instructions

These safety instructions are intended to prevent hazardous situations and/or equipment damage. These instructions indicate the level of potential hazard with the labels of "Caution," "Warning" or "Danger." They are all important notes for safety and must be followed in addition to International Standards (ISO/IEC)\*1), and other safety regulations.

\*1) ISO 4414: Pneumatic fluid power -- General rules relating to systems.

ISO 4413: Hydraulic fluid power -- General rules relating to systems.

IEC 60204-1: Safety of machinery -- Electrical equipment of machines .(Part 1: General requirements)

ISO 10218: Manipulating industrial robots -Safety.

etc.



## Caution

**Caution** indicates a hazard with a low level of risk which, if not avoided, could result in minor or moderate injury.



## Warning

**Warning** indicates a hazard with a medium level of risk which, if not avoided, could result in death or serious injury.



## Danger

**Danger** indicates a hazard with a high level of risk which, if not avoided, will result in death or serious injury.

## Warning

### **1. The compatibility of the product is the responsibility of the person who designs the equipment or decides its specifications.**

Since the product specified here is used under various operating conditions, its compatibility with specific equipment must be decided by the person who designs the equipment or decides its specifications based on necessary analysis and test results.

The expected performance and safety assurance of the equipment will be the responsibility of the person who has determined its compatibility with the product.

This person should also continuously review all specifications of the product referring to its latest catalog information, with a view to giving due consideration to any possibility of equipment failure when configuring the equipment.

### **2. Only personnel with appropriate training should operate machinery and equipment.**

The product specified here may become unsafe if handled incorrectly.

The assembly, operation and maintenance of machines or equipment including our products must be performed by an operator who is appropriately trained and experienced.

### **3. Do not service or attempt to remove product and machinery/equipment until safety is confirmed.**

1. The inspection and maintenance of machinery/equipment should only be performed after measures to prevent falling or runaway of the driven objects have been confirmed.

2. When the product is to be removed, confirm that the safety measures as mentioned above are implemented and the power from any appropriate source is cut, and read and understand the specific product precautions of all relevant products carefully.

3. Before machinery/equipment is restarted, take measures to prevent unexpected operation and malfunction.

### **4. Contact SMC beforehand and take special consideration of safety measures if the product is to be used in any of the following conditions.**

1. Conditions and environments outside of the given specifications, or use outdoors or in a place exposed to direct sunlight.

2. Installation on equipment in conjunction with atomic energy, railways, air navigation, space, shipping, vehicles, military, medical treatment, combustion and recreation, or equipment in contact with food and beverages, emergency stop circuits, clutch and brake circuits in press applications, safety equipment or other applications unsuitable for the standard specifications described in the product catalog.

3. An application which could have negative effects on people, property, or animals requiring special safety analysis.

4. Use in an interlock circuit, which requires the provision of double interlock for possible failure by using a mechanical protective function, and periodical checks to confirm proper operation.



# Common Supply Regulator Safety Instructions

## **Caution**

### **The product is provided for use in manufacturing industries.**

The product herein described is basically provided for peaceful use in manufacturing industries.

If considering using the product in other industries, consult SMC beforehand and exchange specifications or a contract if necessary.

If anything is unclear, contact your nearest sales branch.

## **Limited warranty and Disclaimer/Compliance Requirements**

The product used is subject to the following “Limited warranty and Disclaimer” and “Compliance Requirements”.

Read and accept them before using the product.

### **Limited warranty and Disclaimer**

1. The warranty period of the product is 1 year in service or 1.5 years after the product is delivered, whichever is first.\*2)

Also, the product may have specified durability, running distance or replacement parts. Please consult your nearest sales branch.

2. For any failure or damage reported within the warranty period which is clearly our responsibility, a replacement product or necessary parts will be provided.

This limited warranty applies only to our product independently, and not to any other damage incurred due to the failure of the product.

3. Prior to using SMC products, please read and understand the warranty terms and disclaimers noted in the specified catalog for the particular products.

\*2) Vacuum pads are excluded from this 1 year warranty.

A vacuum pad is a consumable part, so it is warranted for a year after it is delivered.

Also, even within the warranty period, the wear of a product due to the use of the vacuum pad or failure due to the deterioration of rubber material are not covered by the limited warranty.

### **Compliance Requirements**

1. The use of SMC products with production equipment for the manufacture of weapons of mass destruction(WMD) or any other weapon is strictly prohibited.

2. The exports of SMC products or technology from one country to another are governed by the relevant security laws and regulation of the countries involved in the transaction. Prior to the shipment of a SMC product to another country, assure that all local rules governing that export are known and followed.

## **Caution**

### **SMC products are not intended for use as instruments for legal metrology.**

Measurement instruments that SMC manufactures or sells have not been qualified by type approval tests relevant to the metrology (measurement) laws of each country.

Therefore, SMC products cannot be used for business or certification ordained by the metrology (measurement) laws of each country.

## Precautions for Design

### **Warning**

- (1) Polyacetal resin parts are used for the exterior. Organic solvents including thinner, acetone, alcohol and ethylene chloride; chemicals including sulphuric acid, nitric acid and hydrochloric acid; cutting oil, synthetic oils, ester-based compressor oil, alkali, kerosene, gasoline, and thread lock solutions are harmful. Do not use the product where these are present.
- (2) Consult SMC if no leakage is allowed due to the environment, or if the operating fluid is not air.
- (3) Shield from ultra violet light and heat radiation with protective cover.
- (4) A safety device should be installed if output pressure is exceeding the set pressure, otherwise this can cause breakage of outlet device and equipment or lead to malfunction.

### **Caution**

- (1) Allowed air consumption from the exhaust port is 0.1 L/min(ANR) or less.
- (2) When multiple regulators are connected together, supply an adequate amount of air. If air supply is inadequate, the flow rate characteristics (as if when a single product is used alone) will not be obtained.

## Selection

### **Warning**

- (1) Grease used on the internal sliding parts and seals may flow to the outlet side. If this is not acceptable, please consult SMC.
- (2) Residual pressure of product without backflow function is released unstably even though the inlet pressure is released (pressure might be left in the product). Please select a regulator with backflow function to release the residual pressure completely.
- (3) Long absence of operation or operation with outlet circuit sealed or balancing circuit may cause pressure fluctuation in outlet set pressure. Please consult SMC if this is not acceptable.
- (4) Set range of outlet pressure shall be 85% or less of the inlet pressure. Operating at a setting exceeding 85% causes the outlet pressure to be easily affected by fluctuations in flow rate and inlet pressure, leading to instability.
- (5) Since the safety margin is calculated to the maximum regulating pressure range shown in the specification table, the pressure setting may be over the maximum value. However, use the product within the specified range.
- (6) If the product is used with circuit which requires high exhaust sensitivity or set precision, please consult SMC.

### **Caution**

- (1) This product cannot be installed between the solenoid valve and actuator. For that application, please use AR□K-D series.

## Mounting

### **Warning**

- (1) Connect the product ensuring the direction of "1" and "2" for air direction and indicated arrow. Incorrect connection leads to malfunction.
- (2) Install with enough space around the filter regulator to perform regular maintenance and operation. Refer to (P24) the dimensional drawings for necessary space.
- (3) Do not drop or apply impact during transportation or installation. Damage of products or pressure gauge can result in malfunction.
- (4) Do not install in areas with high humidity or high temperature. It may lead to a malfunction of the pressure gauge.

## Adjustment

### Warning

- (1) Adjust the set pressure ensuring correct inlet and outlet pressures. Turning the knob excessively can cause damage to the internal parts.
- (2) Operate the knob by hand. Tools may break the knob.

### Caution

- (1) For the product with a pressure gauge, do not apply pressure exceeding the maximum scale of the pressure gauge in order to protect the gauge.
- (2) Adjust the pressure whilst the pressure is increasing. Pressure may become lower than the set pressure if adjusted by decreasing the value. Rotate the knob clockwise to increase the set pressure. Counterclockwise to decrease the pressure. Moreover, please lock the knob after setting pressure.
- (3) For the regulator with backflow function, upstream pressure needs to be higher than downstream pressure by 0.05MPa or more.
- (4) Outlet pressure may rise when the inlet pressure is discharged and resupplied after pressure setting. In this case, allow flow of air through the product by consuming air at the outlet, which will bring the pressure closer to the set pressure.
- (5) Outlet pressure may change if the product is used for a long period of time. Please confirm the set pressure regularly.
- (6) When pressure difference between the inlet side and the outlet side is large, chattering may occur. In that case, please reduce the pressure difference between the inlet and the outlet. Please consult SMC if chattering continues.

## Piping

### Warning

- (1) Before piping is connected, it should be thoroughly blown out with air (flushing) or washed to remove chips, cutting oil and solid foreign material from inside the pipe. Contamination of piping may cause damage or malfunction.
- (2) When screwing piping or fittings into ports, ensure that chips from the pipe threads or sealing material do not enter the product. When a sealant tape is used, leave 1.5 to 2 thread ridges exposed at the end of the threads.
- (3) Connect piping/fittings using the recommended torque while holding the female thread side tightly. Insufficient tightening torque can cause loose piping or sealing failure. Excess tightening torque may cause damage to threads. If the female side is not held while tightening, excessive force will be applied to the bracket directly, causing breakage.

Recommended tightening torque (Unit: Nm)

Thread	1/8	1/4	3/8	1/2
Torque	7 to 9	12 to 14	22 to 24	28 to 30

- (4) Do not apply torsion or bending moment other than the weight of the product itself. External piping needs to be supported separately as it may cause damage. Non-flexible piping like steel tube is susceptible to excessive moment load or vibration. Insert flexible tubes to prevent this.

## Air Supply

### **Warning**

- (1) Use clean air. Do not use compressed air containing chemicals, organic solvent, synthetic oil or corrosive gas as it may be cause of breakage of components or operation failure.
- (2) Air containing too much moisture may cause malfunction. Install an air drier or aftercooler before the air combination.

## Maintenance

### **Warning**

- (1) Release the pressure in the product to the atmosphere when replacing parts or removing piping.
- (2) Maintenance and checks should be done by following the procedure in this operation manual. Incorrect handling of the product may cause breakage, operation failure of the equipment or device.

### **Caution**

- (1) If an emergency countermeasure is taken during setting failure or exhaust leakage, the internal sliding part of the valve and valve seat should be checked before performing the countermeasure.

## 2. Application

This product aims at regulating pressure of air lines from common supply.

## 3. Standard Specifications

Model		AR20M-D		AR30M-D		AR40M-D	
Port size		IN	OUT	IN	OUT	IN	OUT
		1/8	1/8	-	-	-	-
		1/4	1/8 1/4	1/4	1/4	-	-
		-	-	3/8	1/4	3/8	1/4 3/8
		-	-	-	-	1/2	1/4 3/8
Pressure gauge port size <sup>Note 1)</sup>		1/8					
Fluid		Air					
Ambient and fluid temperature <sup>Note 2)</sup>		-5 to 60°C (No freezing)					
Proof pressure		1.5 MPa					
Max. operatin pressure		1.0 MPa					
Set pressure range	Without backflow function	0.05 to 0.85 MPa					
	With backflow function	0.1 to 0.85 MPa					
Construction		Relieving type					
Weight (kg)		0.16		0.29		0.50	

Note 1) Pressure gauge connection threads are not available for F.R.L. units with a square embedded type pressure gauge, a right angle square type pressure gauge, or with a digital pressure switch.

Note 2) -5 to 50°C for the products with the digital pressure switch.



## 4. How to Order

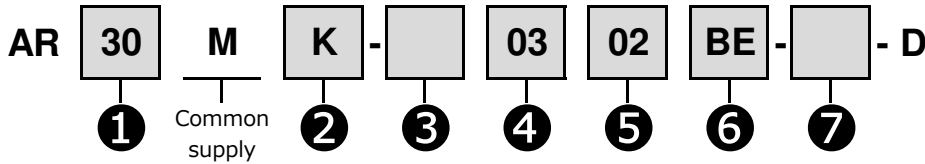

		Symbol	Description	①				
				Body size				
				20	30	40		
②	With backflow function	Nil	Without backflow function	●	●	●		
		K	With backflow function	●	●	●		
③	Thread type	Nil	Rc	●	●	●		
		N	N P T	●	●	●		
		F	G	●	●	●		
④	Port size (IN)	01	1 / 8	●	—	—		
		02	1 / 4	●	●	—		
		03	3 / 8	—	●	●		
		04	1 / 2	—	—	●		
⑤	Port size (OUT)	01	1 / 8	●	—	—		
		02	1 / 4	○ <sup>Note 1)</sup>	●	●		
		03	3 / 8	—	—	●		
⑥	Option <sup>Note 2)</sup>	a	Mounting	Nil	Without mounting option	●	●	●
				B	With bracket	●	●	●
				H	With set nut (for panel mount)	●	●	●
	b	Pressure gauge	Nil	Without pressure gauge	●	●	●	
			E	Square embedded type pressure gauge (with limit indicator)	●	●	●	
			G	Round type pressure gauge (with limit indicator)	●	●	●	
			J	Right angle square type pressure gauge (with limit indicator)	●	●	●	
			M	Round type pressure gauge (with color zone)	●	●	●	
			Digital pressure switch	E1	NPN output / Wiring bottom entry	●	●	●
				E2	NPN output / Wiring top entry	●	●	●
	E3	PNP output / Wiring bottom entry		●	●	●		
	⑦	Semi-standard <sup>Note 2)</sup>	c	Set pressure <sup>Note 3)</sup>	Nil	0.05 to 0.85 MPa setting	●	●
1					0.02 to 0.2 MPa setting	●	●	●
d			Exhaust mechanism	Nil	Relieving type	●	●	●
				N	Non-relieving type	●	●	●
e			Knob	Nil	Downward	●	●	●
	Y	Upward		●	●	●		
f	Unit indication	Nil	Unit on product label: MPa, Pressure gauge in SI units: MPa	●	●	●		
		Z	Unit on product label: psi, Pressure gauge: MPa/psi dual scale	○ <sup>Note 4)</sup>	○ <sup>Note 4)</sup>	○ <sup>Note 4)</sup>		
		ZA	Digital pressure switch: With unit selection function	○ <sup>Note 5)</sup>	○ <sup>Note 5)</sup>	○ <sup>Note 5)</sup>		

Note 1) Selectable when the port size of the IN side is 1/4.

● : Available for all port size.

Note 2) ⑥Option and ⑦Semi-standard: Select one each for a to f.

○ : Available depending on options. Refer to the notes.

Note 3) Minimum set pressure is 0.1MPa for backflow function type.

Note 4) For NPT thread type only.

Note 5) Select with an option E1, E2, E3 or E4.

## 5. Options

Without pressure gauge/  
With round type pressure gauge

With square embedded type pressure gauge/  
With right angle square type pressure gauge/  
With digital pressure switch  
(Backflow function: No/Yes)

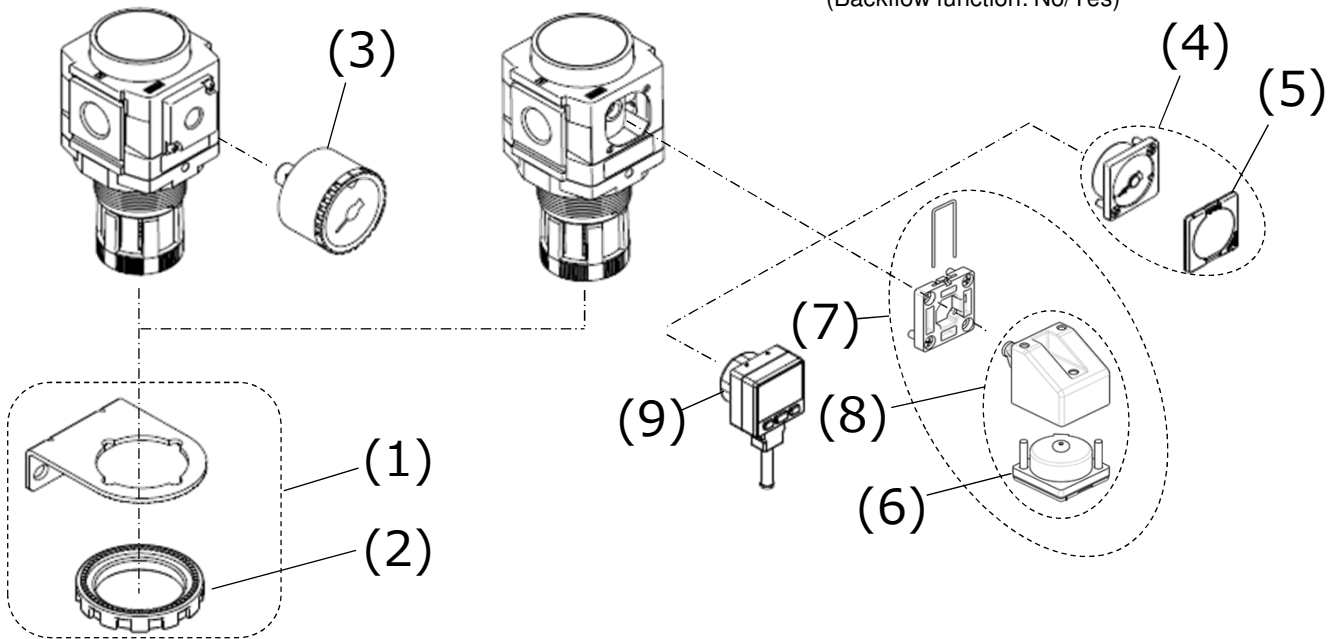

### Options

No.	Description	Piping thread type	Semi-standard specification	Part No.				
				AR20M-D	AR30M-D	AR40M-D		
(1)	Bracket assembly <sup>Note 1)</sup>	—	—	AR23P-270AS	AR33P-270AS	AR43P-270AS		
(2)	Set nut	—	—	AR23P-260S	AR33P-260S	AR43P-260S		
(3)	Pressure gauge <sup>Note 2)</sup> (Round type)	Rc	—	G36-10-01		G46-10-01		
		NPT	—	G36-10-N01		G46-10-N01		
			Z : Both in MPa and psi	G36-P10-N01-X30		G46-P10-N01-X30		
	Pressure gauge <sup>Note 2)</sup> (Round type, with color zone)	G	—	G36-10-01		G46-10-01		
		Rc	—	G36-10-01-L		G46-10-01-L		
		NPT	—	G36-10-N01-L		G46-10-N01-L		
(4)	Square embedded type pressure gauge <sup>Note 3)</sup> (Including part (5))	—	—	GC3-10AS-D				
		NPT	Z : Both in MPa and psi	GC3-P10AS-D-X30				
			—	136150A				
(6)	Right angle square type pressure gauge <sup>Note 3)</sup>	—	Z : Both in MPa and psi	GC3-10AS-J-D				
		NPT	—	GC3-P10AS-J-D-X30				
(7)	Right angle square type pressure gauge (with mounting accessories) <sup>Note 4)</sup>	—	Z : Both in MPa and psi	GC3-10AS-JA-D				
		NPT	—	GC3-P10AS-JA-D-X30				
(8)	Right angle square type pressure gauge assembly <sup>Note 5)</sup>	—	Z : Both in MPa and psi	GC3-10AS-JB-D				
		NPT	—	GC3-P10AS-JB-D-X30				
(9)	Digital pressure switch (with accessories for mounting)	—	—	<Common for all sizes>				
				—	Output specification	Bottom entry wiring	Top entry wiring	
					NPN	ISE35-N-25-MLA-X523	ISE35-R-25-MLA-X523	
				—	ZA : Unit selection function	NPN	ISE35-N-65-MLA-X523	ISE35-R-65-MLA-X523
						PNP	ISE35-N-25-LA-X523	ISE35-R-25-LA-X523
				NPT	Z : Unit selection function Initial setting: psi	NPN	ISE35-N-65-LA-X523	ISE35-R-65-LA-X523
PNP	ISE35-N-25-PLA-X523	ISE35-R-25-PLA-X523						

Note) The numbers in the table and structural drawings are consistent with the numbers in sections [10. How to Replace the Components] (P16-21) and [11. Disassembly Drawing] (P22-23).

Note 1) This is an assembly of a bracket and set nut (2).

Note 2) Part number for 0.2 MPa: G36-4-01 (Rc type) / G36-4-N01 (NPT type) / G36-P4-N01-X30 (NPT, Z type).  
G46-4-01 (Rc type) / G46-4-N01 (NPT type) / G46-P4-N01-X30 (NPT, Z type).

Note 3) With O-ring (1 pc.) and mounting screws (2 pcs.). Part number for 0.2 MPa: GC3-4AS(-J)-D (Rc, NPT type) / GC3-P4AS(-J)-D-X30 (NPT, Z type).

Note 4) In addition to the pressure gauge with a right angle adapter assembled, an adapter, lock pin, O-ring (1 pc.) and mounting screws (2 pcs.) are included.

Note 5) In addition to the pressure gauge with a right angle adapter assembled, an O-ring (1 pc.) is included.

## 6. Structural Drawing and Replacement Parts

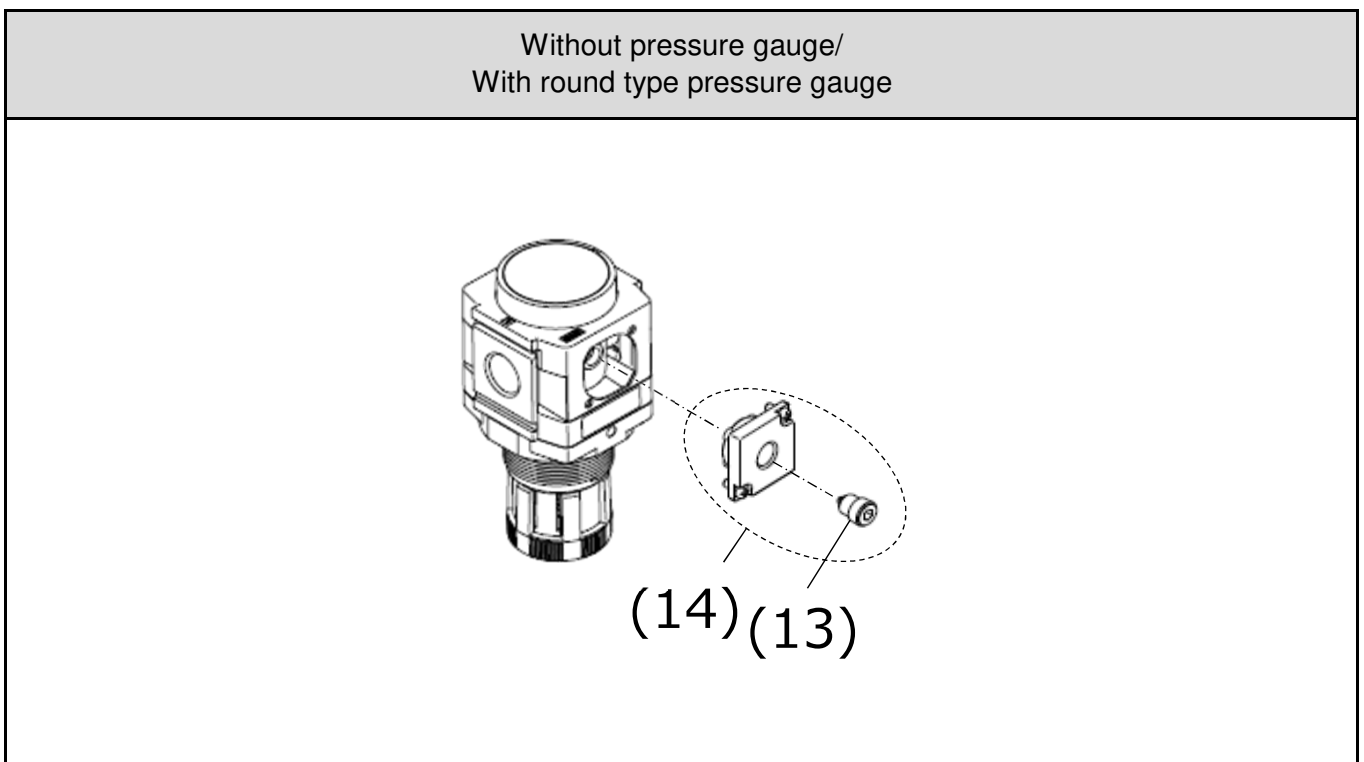
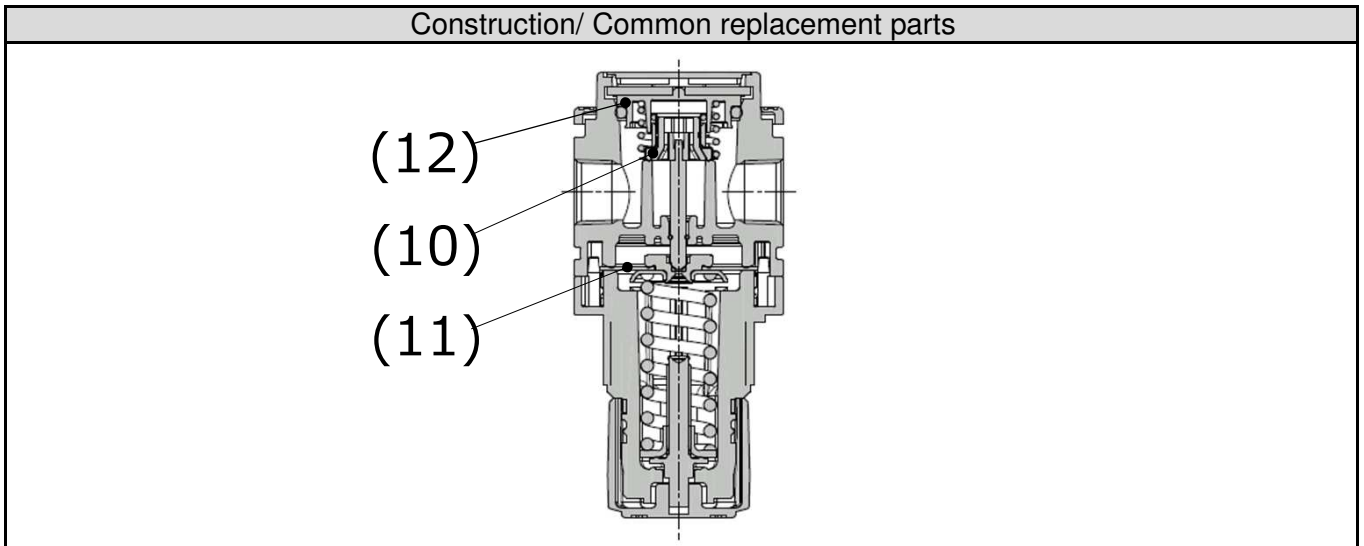

### Replacement part

Component No.	Description	Piping thread type	Semi-standard specification	Part No.		
				AR20M-D	AR30M-D	AR40M-D
(10)	Valve assembly	-	- : Without backflow function	AR24P-060AS	AR34P-060AS	AR44P-060AS
			K : With backflow function	AR24KP-560AS	AR34KP-560AS	AR44KP-560AS
(11)	Diaphragm assembly	-	- : Relief	AR24P-150AS	AR34P-150AS	AR44P-150AS
			N : Non-relief	AR24P-150AS-N	AR34P-150AS-N	AR44P-150AS-N
(12)	Valve guide assembly	-	-	AR24P-050AS	AR34P-050AS	AR44P-050AS
(13)	Plug (with O-ring)	Rc / G	-	AR24P-370AS-01		
		NPT	-	AR24P-370AS-N01		
(14)	Plug assembly (Including part (13))	Rc	-	AR24P-320AS-01		
		NPT	-	AR24P-320AS-N01		
		G	-	AR24P-320AS-F01		

The numbers in the table and structural drawings are consistent with the numbers in sections [10. How to Replace the Components] (P16-21) and [11. Disassembly Drawing] (P22-23).

## 7. Assembly of Optional Parts

### 7-1. Bracket (Panel mount)

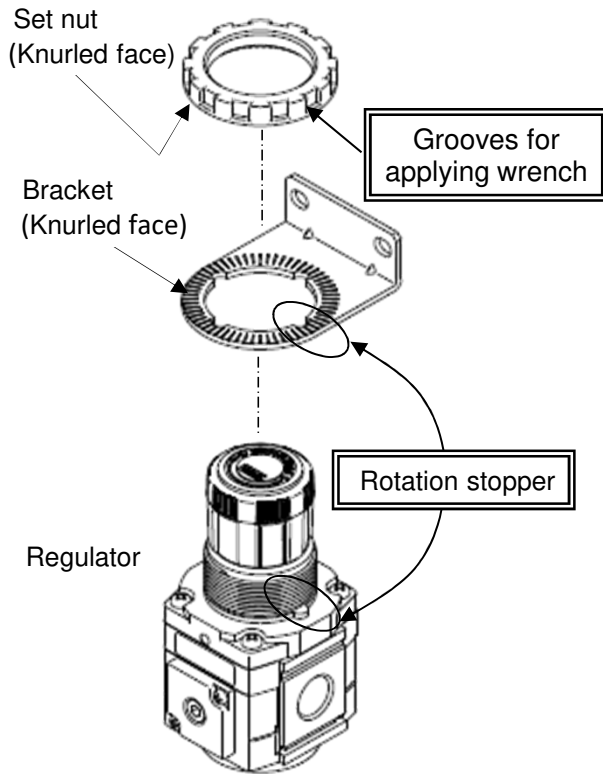

- 1) **Bracket mounting**  
Mount the bracket to the regulator as shown in the picture.  
Assemble so that the rotation stopper of the regulator and the bracket are engaged properly.
- 2) **Secure with the set nut**  
Ensure that the knurled faces of the bracket and the set nut are facing each other.
- 3) **Tightening**  
Turn the set nut while the regulator is aligned correctly with the bracket. The knurling of the bracket and set nut stops loosening of the screw. Usually, these can be tightened adequately by hand. (Extra tightening is recommended for panel mounting).  
Note) When retightening  
Please use a hook wrench on the grooves of the set nut. After hand tightening, follow the values in the table below for retightening.

Model	Tool size	Amount of retightening	Reference torque
AR20M-D	34/38	2 to 5 notch	2.0+/-0.2 N m
AR30M-D	52/55		3.5+/-0.3 N m
AR40M-D	52/55		4.0+/-0.4 N m

### 7-2. Pressure gauge (round type)

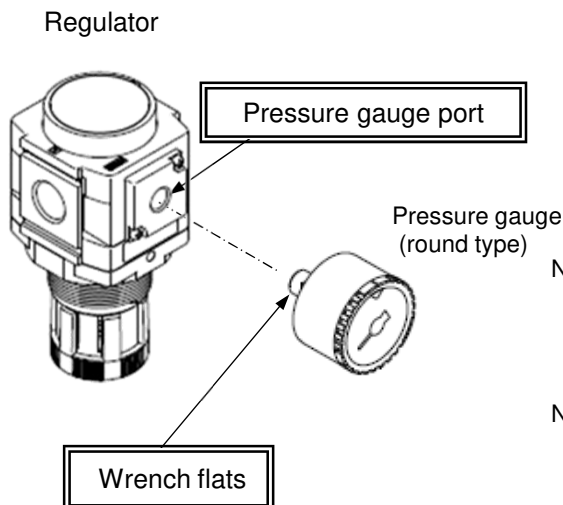

- 1) **Pressure gauge mounting (round type)**  
Before mounting the pressure gauge onto the pressure gauge port of the regulator, confirm that sealing material has been applied to the pressure gauge.  
Please refer to "Piping" on page 5 when using sealing tape.

#### Wrench size

Model	Tool size
AR20M-D	14
AR30M-D	
AR40M-D	

- Note1) **Positioning of pressure gauge**  
Adjust the pressure gauge position by tightening it.  
Adjustment in loosening direction may cause air leakage.
- Note2) **No plug is mounted onto the pressure gauge port of product with a round type pressure gauge.**
- Note3) **Torque control**  
Please use the value in the torque table described in "Piping" on page 5 when controlling the tightening torque.

## 8. Operation and Adjustment

### 8-1. Pressure regulation

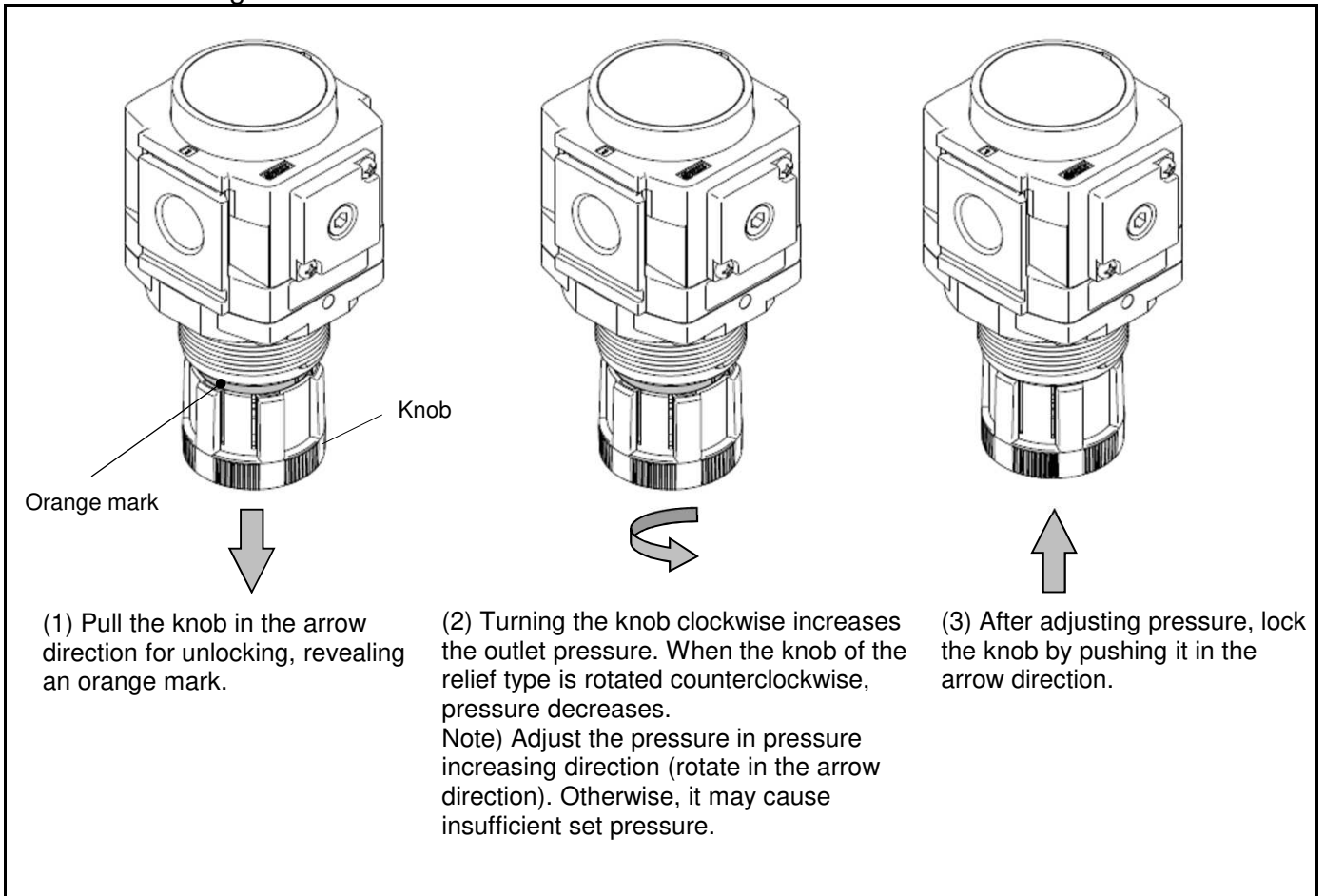

### 8-2. Indicator adjustment of the square embedded type pressure gauge

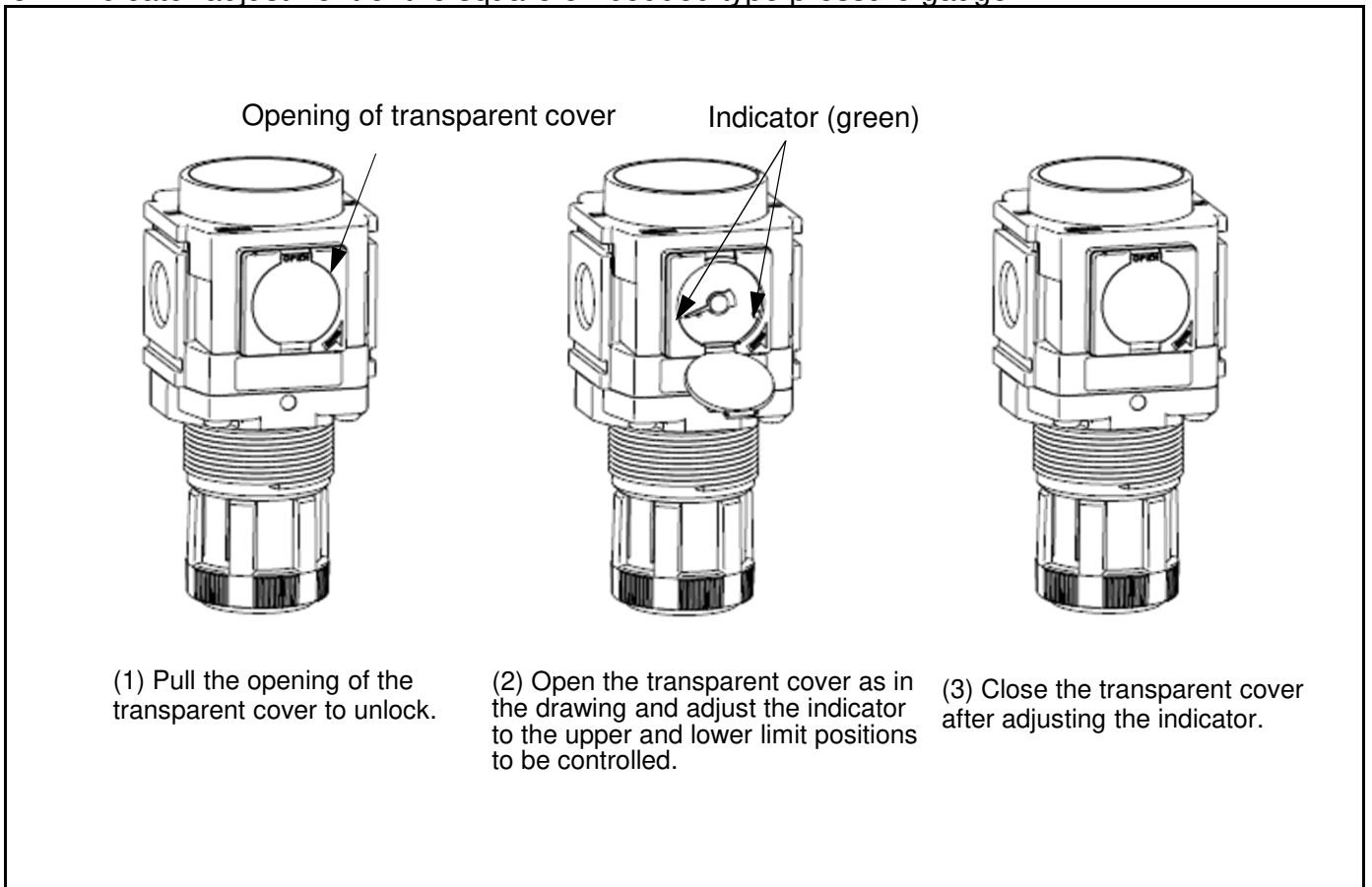

## 8. Operation and Adjustment

### 8-3. Adjustment of the right angle square type pressure gauge

#### Adjustment of mounting orientation of pressure gauge

The pressure gauge is secured to the product by means of a lock pin and by removing the lock pin, it is possible to adjust the mounting orientation of the gauge in 90 degree rotations.

When adjusting the orientation, follow the procedures 1) of Disassembly and 9) and 10) of Assembly in 10-4. Right Angle Square Type Pressure Gauge Replacement (P19).

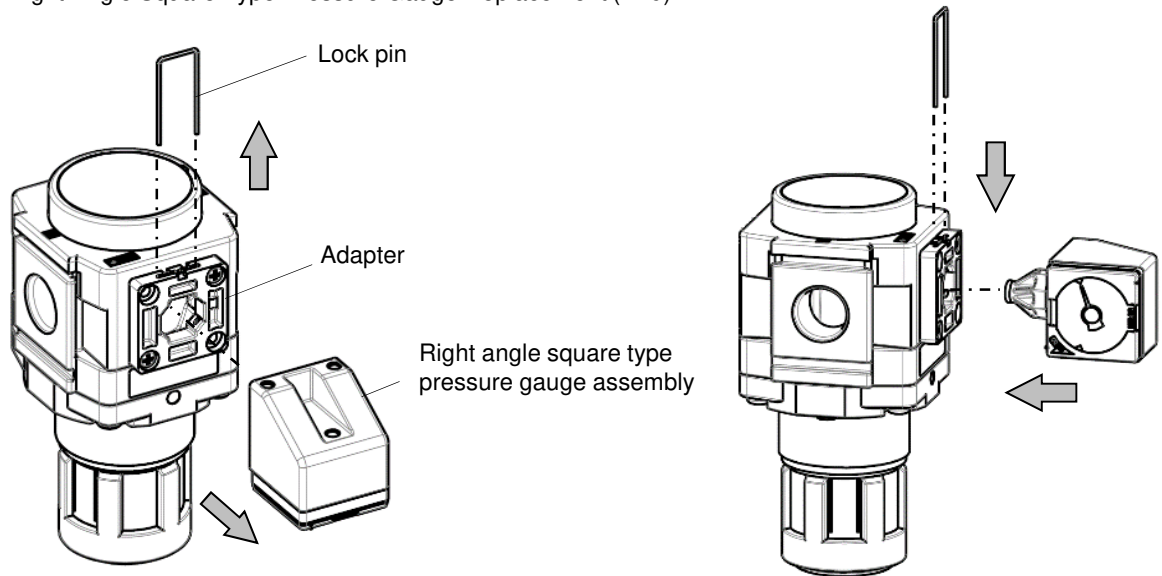

Example: Rotate by 90 degrees from standard orientation

#### Adjustment of orientation of pressure gauge scale plate

The pressure gauge is secured to the right angle adapter by means of screws and by removing the screws, it is possible to adjust the mounting orientation of the scale plate in 90 degree rotations.

When adjusting the orientation of the pressure gauge scale plate, follow the procedures 1) to 3) of Disassembly and 6) to 10) of Assembly in 10-4. Right Angle Square Type Pressure Gauge Replacement (P19).

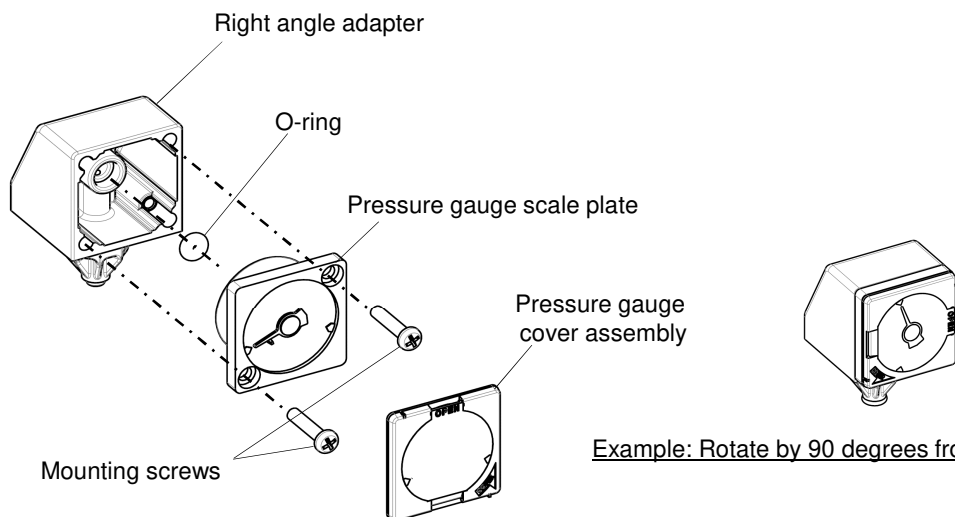

Example: Rotate by 90 degrees from standard orientation

## 9. Trouble Shooting

Refer to sections [10. How to Replace the Components] (P16-21) and [11. Disassembly Drawing] (P22-23).

Problem		Possible cause	Countermeasure	Page for reference
Category	Failure			
Pressure	The pressure can not be adjusted.	1. Air pressure is not supplied to the inlet.	Check the supply pressure. Ensure that the supply side ball valve is opened.	—
		2. The product is not correctly mounted in the direction of flow.	Install the product correctly after confirming the direction of flow. The side with “1” for IN and “2” is for OUT.	—
		3. Pressure regulating spring is damaged.	Replace the pressure regulating spring.	P16
		4. Valve spring is damaged.	Replace the valve spring.	P17
		5. Foreign matter is caught in the valve seat or valve sliding O-ring. In case of back flow function type, foreign matter may get caught in the check valve seal.	Remove the valve and eliminate foreign materials. When the condition is not improved, replace the valve guide assembly and valve assembly.	P17
		6. Valve seat is damaged.	Replace the valve assembly.	P17
	The set pressure does not become zero even when the knob is loosened.	1. Foreign matter is caught in the valve seat or valve sliding O-ring. In case of back flow function type, foreign matter may get caught in the check valve seal.	Remove the valve and eliminate foreign materials. When the condition is not improved, replace the valve guide assembly and valve assembly.	P17
		2. Valve seat is damaged.	Replace the valve assembly.	P17
		3. Valve spring is damaged.	Replace the valve spring.	P17
		4. The valve is fixed in an opened position.	Clean the valve sliding surface of O-ring and apply grease additionally.	P17
Air leakage	Air leaks from the bonnet exhaust port.	1. The product is not correctly mounted in the direction of flow.	Install the product correctly after confirming the direction of flow. The side with “1” for IN and “2” is for OUT.	—
		2. Diaphragm assembly is damaged.	Replace the diaphragm assembly.	P16
		3. Foreign matter is caught in seating part of the relief valve.	Clean the seating part of the relief valve or replace the diaphragm assembly.	P16
		4. Foreign matter got caught in the valve seat or valve sliding O-ring. In case of back flow function type, foreign matter may get caught in the check valve seal.	Remove the valve guide and clean the valve seat and valve sliding O-ring (or check valve seal). After cleaning then, apply grease to the valve sliding O-ring (or check valve seal) and valve guide sliding part.	P17
		5. Valve seat is damaged.	Replace the valve assembly.	P17

Note ) Fluorine grease is recommended when applying additional grease.

Refer to sections [10. How to Replace the Components] (P16-21) and [11. Disassembly Drawing] (P22-23).

Problem		Possible cause	Countermeasure	Page for reference
Category	Failure			
Air leakage	Air leaks from the bonnet exhaust port.	6. Back pressure exceeding the set pressure is applied to the downstream.	Revise the air circuit so that back pressure does not exceed the set pressure.	—
	Air leaks from between the bonnet and the body.	1. Loosened bonnet screws.	Fasten the bonnet.	P16
		2. Diaphragm assembly is damaged.	Replace the diaphragm assembly.	P16
Backward flow	Air does not flow backwards.	1. Product without backflow function is used.	Check the product number if backflow function is equipped.	P8
		2. Foreign matter caught in the check valve seal leads to malfunction. Or, the check valve seal is stuck.	Clean the check valve seal and add grease. If the condition is not improved, replace the valve guide assembly and check valve assembly.	P17

Note ) Fluorine grease is recommended when applying additional grease.



# 10. How to Replace the Products

## Warning

Before replacement, make sure that no pressure remains in the equipment.

Also, make sure to loosen the knob of the regulator so that the set pressure is zero.

After replacement, confirm that the product satisfies specific functions and no external leakage occurs before operating it.

### 10-1. Diaphragm Assembly Replacement

Applicable model	Work category	Step	Tool	Criteria						
AR20M AR30M AR40M	Disassembly	1) Loosen the knob completely before disassembly.	-	-						
		2) Remove the 4 screws and remove the bonnet.	Phillips screwdriver	-						
		3) Remove the pressure regulating screw assembly, pressure regulating spring, and diaphragm assembly in that order.	-	-						
	Assembly	4) Assemble the diaphragm assembly, pressure regulating spring, and then pressure regulating screw assembly.	-	-	Direction of diaphragm assembly and pressure regulating screw assembly					
		5) Assemble the bonnet to the body. Mount the bonnet to the body with the protuded side facing upwards an inline with ports. Tighten four mounting screws temporarily, then tightening them diagonally and evenly to fix the bonnet.	Phillips screwdriver	<table border="1"> <tr> <td colspan="2">Tightening torque</td> </tr> <tr> <td>AR20M</td> <td>2.35+/-0.3 N·m</td> </tr> <tr> <td>AR30M</td> <td></td> </tr> <tr> <td>AR40M</td> <td>3.5 ±0.3N·m</td> </tr> </table>	Tightening torque		AR20M	2.35+/-0.3 N·m	AR30M	
Tightening torque										
AR20M	2.35+/-0.3 N·m									
AR30M										
AR40M	3.5 ±0.3N·m									

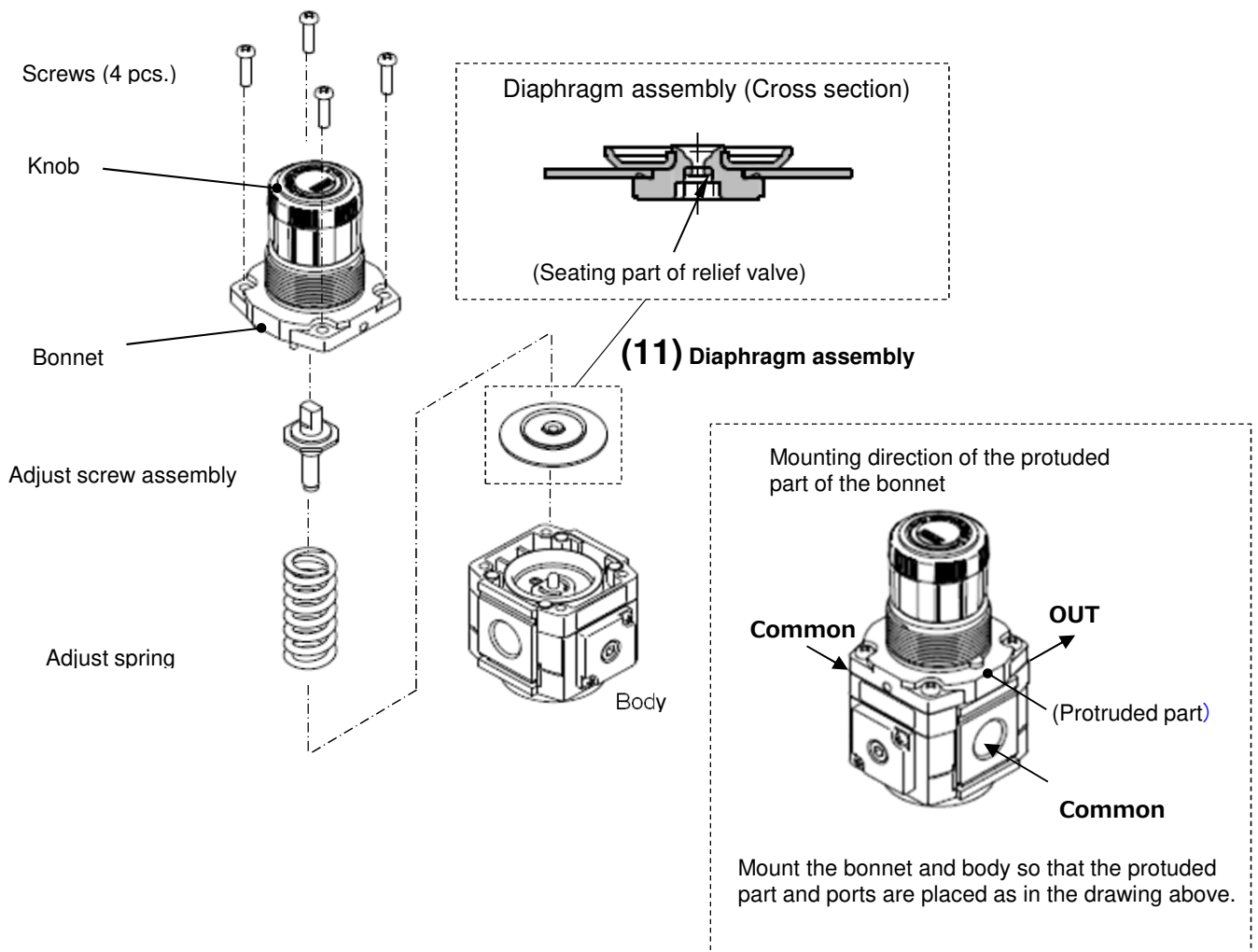

## 10-2. Valve Guide Assembly and Valve Assembly Replacement

Applicable model	Work category	Step	Tool	Criteria
AR20M AR30M AR40M	Disassembly	1) Remove the cap. Insert a precision screwdriver (-) between the body and cap to lift the cap.	Precision screwdriver (-)	—
		2) Remove the cover. Insert round pliers into the small holes of the cover and rotate 45 degree to the left or right, then lift the cover to remove.	Round pliers Nominal: 125	—
		3) Remove the valve guide assembly. Remove it while lifting the circumferential part with a precision screwdriver.	Precision screwdriver (-)	—
		4) Remove the valve spring.	—	—
		5) Remove the valve assembly.	—	—
	Assembly	6) After replacing the removed components with new components, place them into the regulator. Assemble the components in reverse order to the removal procedure.	—	(See below for the mounting direction of the components.)

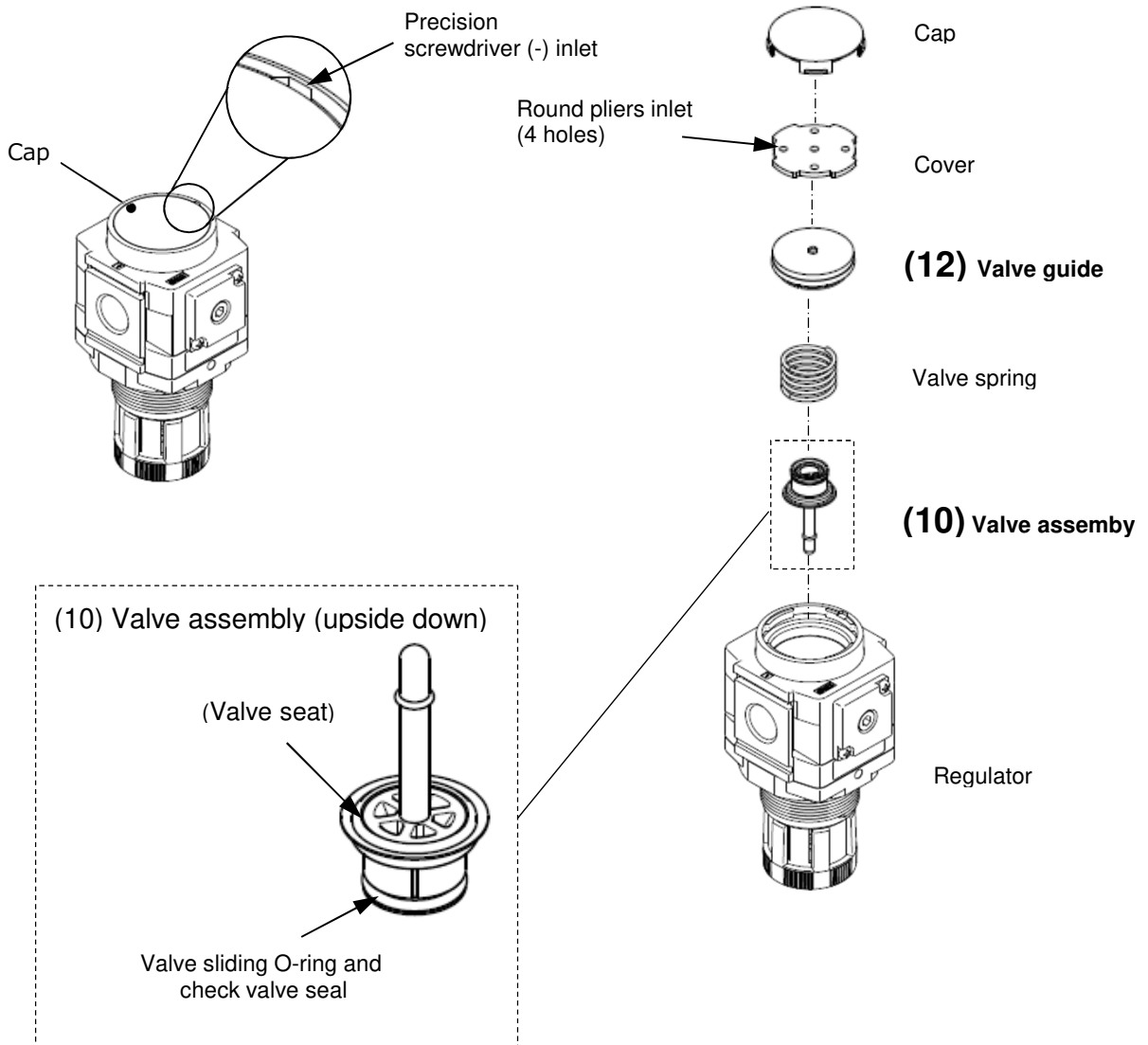

### 10-3. Square Embedded Type Pressure Gauge Replacement

Applicable model	Work category	Step	Tool	Criteria
AR20M AR30M AR40M	Disassembly	1) Remove the pressure gauge cover. Rotate the pressure gauge cover 15 degrees in the arrow direction (counterclockwise) and pull it out.	—	—
		2) Remove the pressure gauge. Remove the 2 mounting screws and remove the pressure gauge.	Phillips screwdriver	—
	Assembly	3) Confirm that the O-ring is mounted onto the pressure gauge. When the O-ring comes out or is left on the regulator, mount the O-ring to the pressure gauge correctly.	—	Presence of the O-ring
		4) Mount the pressure gauge. Mount the pressure gauge to the regulator with the mounting screws and tighten the screws referring to the tightening torque to the specified criteria.	Phillips screwdriver	Tightening torque: 0.85+/-0.05 N m
		5) Mount the pressure gauge cover. Set the pressure gauge cover with its arrow on the lower right corner. Mate the 2 fingers of the pressure gauge cover with the 2 finger slits of the pressure gauge, and rotate the pressure gauge cover 15 degrees to the opposite direction of the arrow (clockwise).	—	—

\*Note ) Applicable to the product with square embedded type pressure gauge (E).

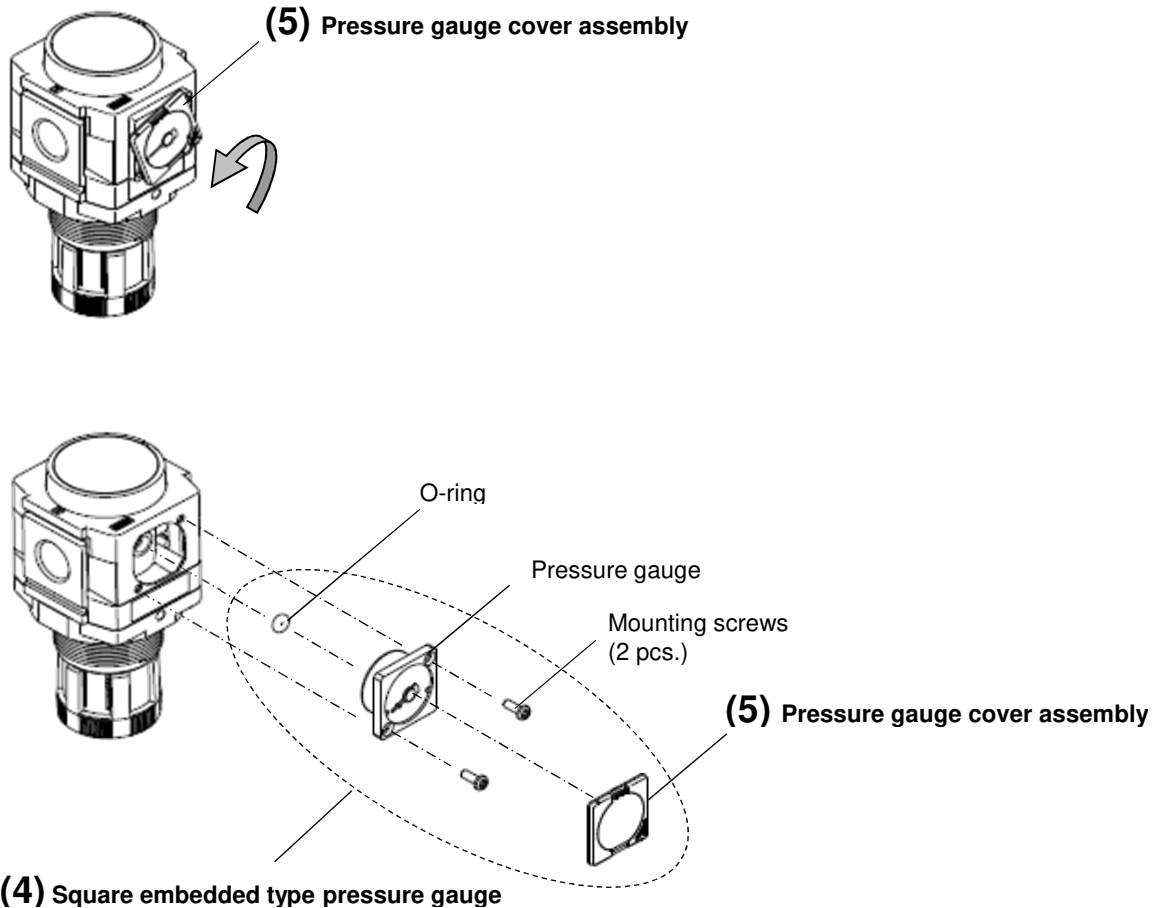

### 10-4. Right Angle Square Type Pressure Gauge Replacement

Applicable model	Work category	Procedure	Tool	Criteria
AR20M AR30M AR40M	Disassembly	1) Remove the right angle square type pressure gauge assembly. Remove the lock pin by using a flat blade screwdriver. Pull the right angle square type pressure gauge assembly out from the product.	Precision screwdriver (-)	—
		2) Remove the pressure gauge cover assembly. Rotate the pressure gauge cover assembly by 15 degrees in the arrow direction (counterclockwise) and pull the cover assembly toward you to dismount it.	—	—
		3) Remove the pressure gauge. Remove the two mounting screws and dismount the pressure gauge from the right angle adapter.	Phillips screwdriver	—
		4) Remove the adapter. Remove the two mounting screws and dismount the adapter from the product.	Phillips screwdriver	—
	Assembly	5) Mount the adapter. Temporarily mount the adapter to the product in the orientation shown in the figure below by the mounting screws and tighten the screws to the tightening torque specified in the right column, to secure the adapter.	Phillips screwdriver	Tightening torque: 0.6+/-0.05 N m
		6) Confirm that the O-ring is mounted on the pressure gauge. When the O-ring has been dropped or is left on the right angle adapter side, mount the O-ring to the pressure gauge again.	—	Presence of the O-ring
		7) Mount the pressure gauge. Temporarily mount the pressure gauge to the right angle adapter with the mounting screws, and then tighten the screws to the tightening torque specified in the right column to secure the pressure gauge.	Phillips screwdriver	Tightening torque: 0.32+/-0.05 N m
		8) Mount the pressure gauge cover assembly. Engage the two fingers of the pressure gauge cover assembly with the two finger slits of the pressure gauge so that the arrow on the cover assembly is pointing the lower right, and rotate the pressure gauge cover by 15 degrees to the direction opposite to the arrow (clockwise).	—	—
		9) Confirm that the O-ring is mounted on the right angle square type pressure gauge assembly. When the O-ring has been dropped or is left on the product side, mount the O-ring to the right angle square type pressure gauge assembly again.	—	Presence of the O-ring
		10) Mount the right angle square type pressure gauge assembly. Insert the right angle square type pressure gauge assembly until it makes contact with the adapter. In that condition, insert the lock pin again to the predetermined position.	—	Lock pin insertion condition

Note) Applicable to the product with right angle square type pressure gauge (J).

#### Disassembly

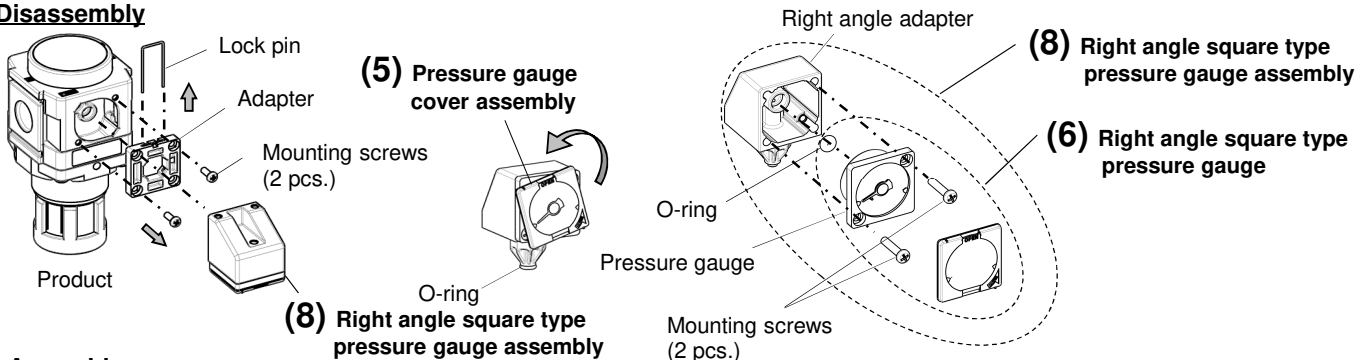

#### Assembly

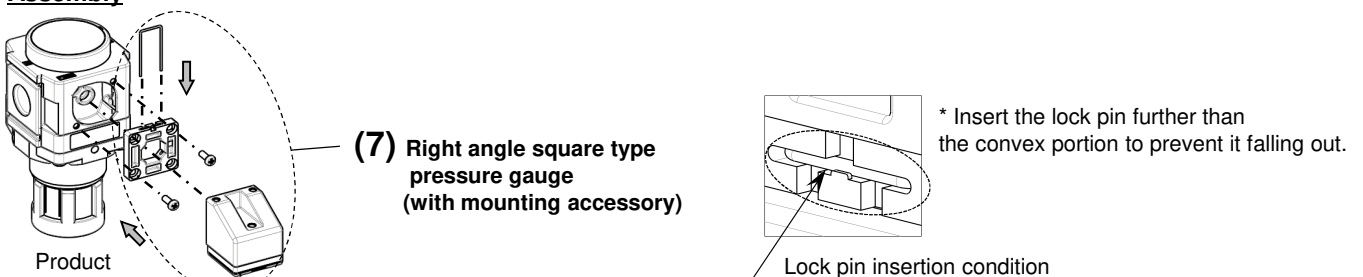

### 10-5. Plug (with O-ring) Replacement

Applicable model	Work category	Step	Tool	Criteria
AR20M AR30M AR40M	Disassembly	1) Remove the plug (with O-ring) by turning anti-clockwise.	Hexagon wrench (Nominal size: 4)	—
	Assembly	2) Assemble the plug (with O-ring) by turning clockwise to the specified tightening torque.	Hexagon wrench (Nominal size: 4)	Tightening torque: 0.6+/-0.05 N m

Note ) Applicable to the product without pressure gauge.

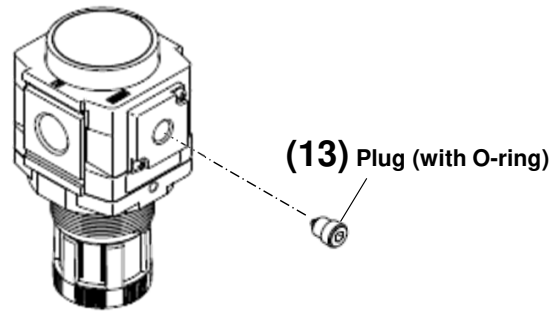

### 10-6. Plug Assembly Replacement

Applicable model	Work category	Step	Tool	Criteria
AR20M AR30M AR40M	Disassembly	1) Remove the plug assembly. Remove the 2 mounting screws and remove the plug assembly.	Phillips screwdriver	—
	Assembly	2) Confirm that the O-ring is mounted onto the component "A". When the O-ring comes out or is left on the regulator, mount the O-ring to the plug assembly correctly.	—	Presence of the O-ring
		3) Assemble the plug assembly. Assemble the plug assembly to the product with the mounting screws and tighten the screws referring to the tightening torque specified in the right column.	Phillips screwdriver	Tightening torque: 0.6+/-0.05 N m

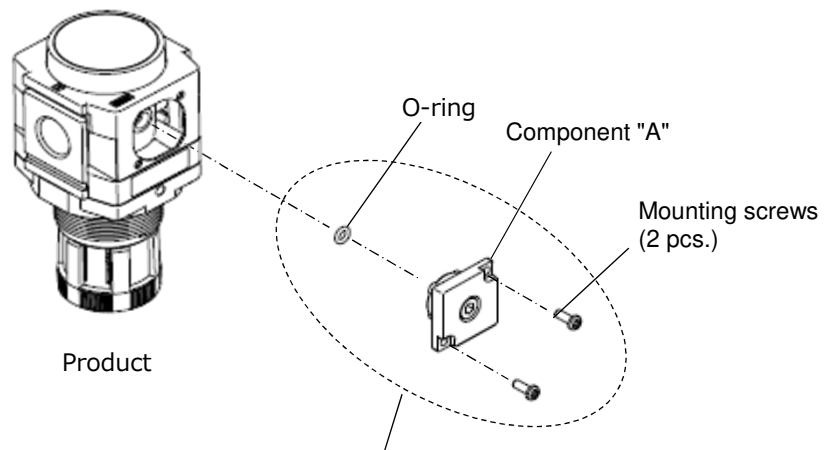

**(14) Plug assembly**

# 11. Disassembly Drawing

11-1. AR20M-D / AR30M-D / AR40M-D

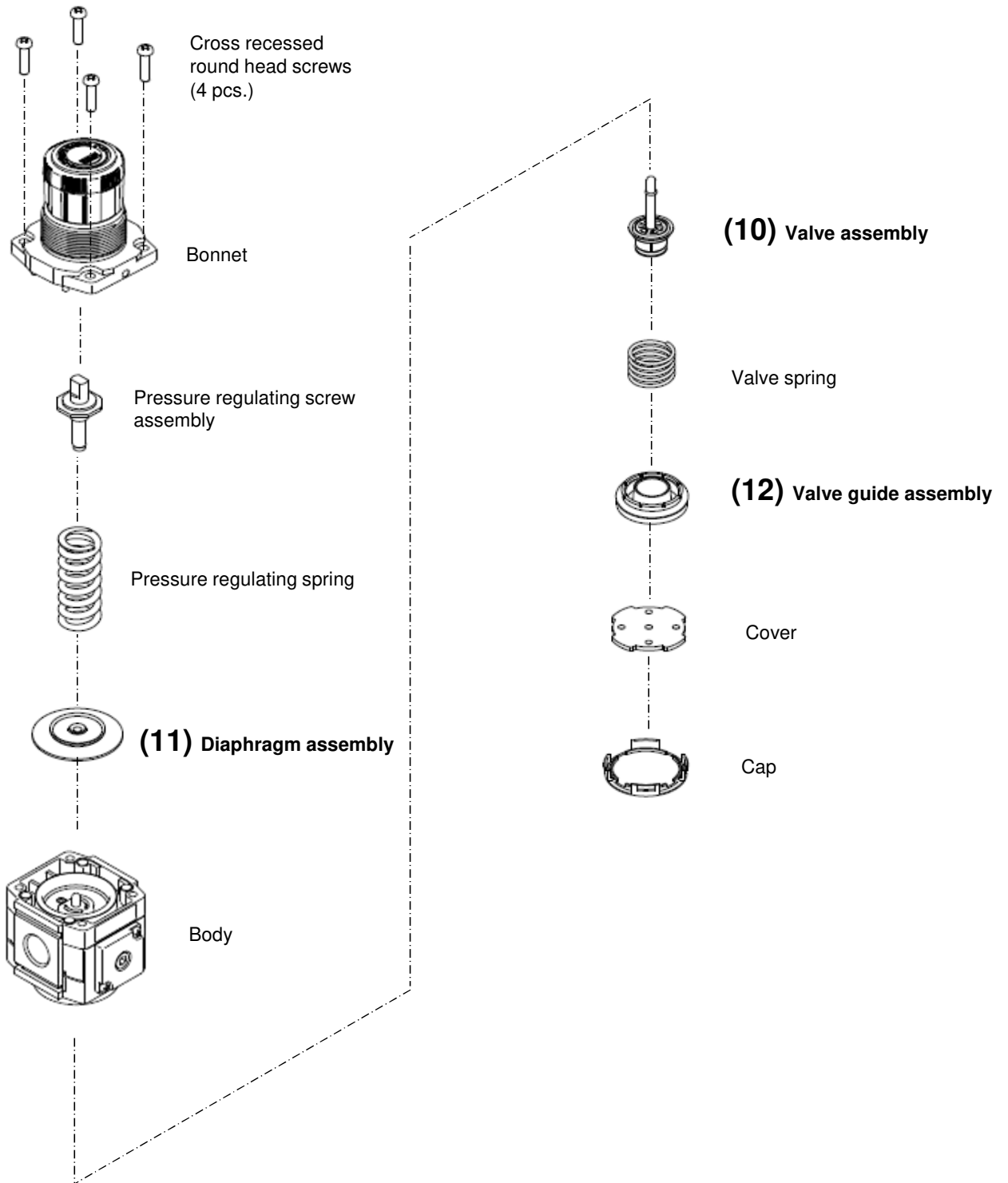

## 11-2. Disassembly Drawing of the Pressure Gauge Port

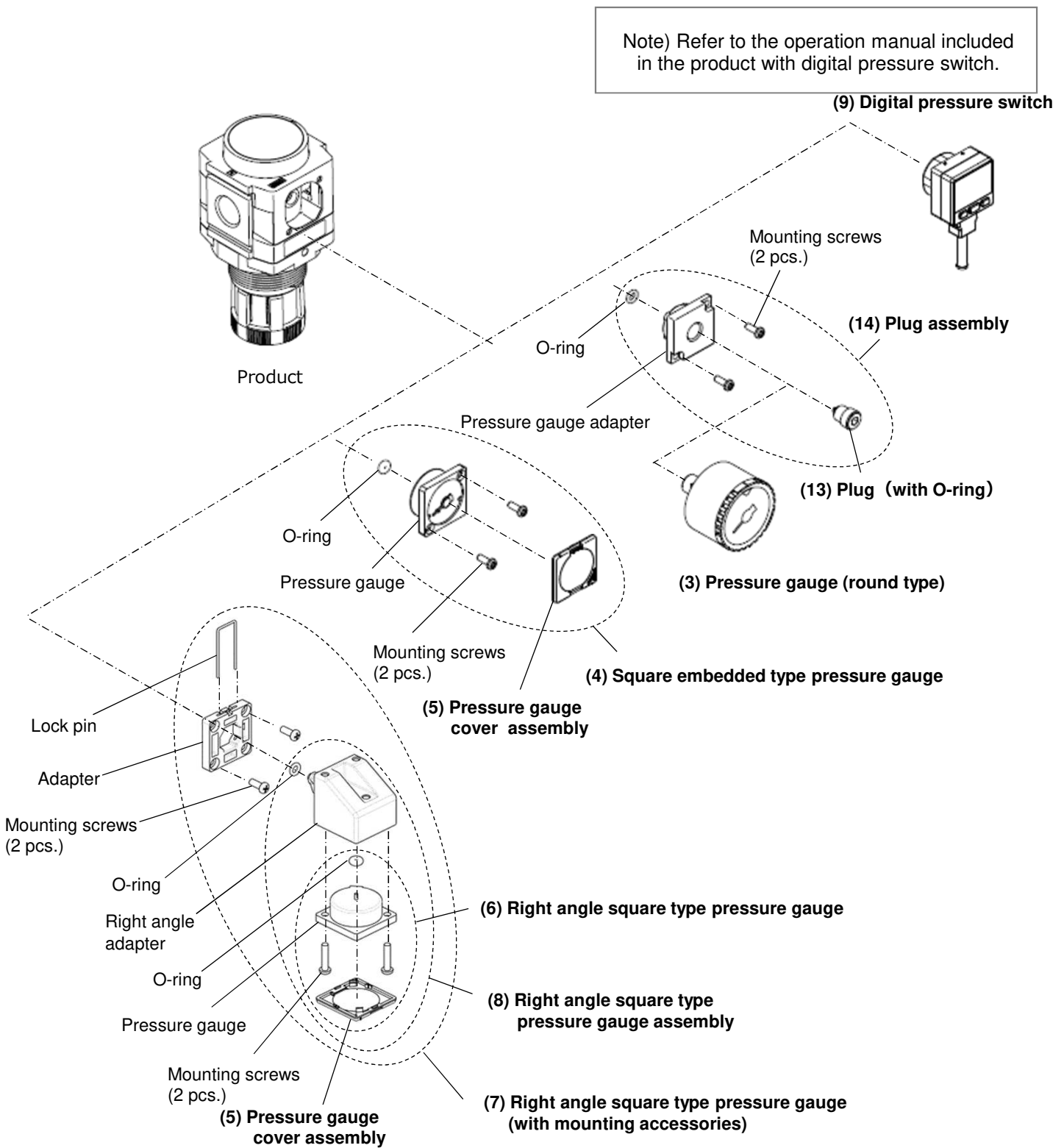

- When (4) square embedded type pressure gauge and (9) digital pressure switch is mounted, tighten with the torque of  $0.85 \pm 0.05 \text{ N} \cdot \text{m}$ .  
When another part is mounted, tighten with the torque of  $0.6 \pm 0.05 \text{ N} \cdot \text{m}$ .



## 12. Dimensions

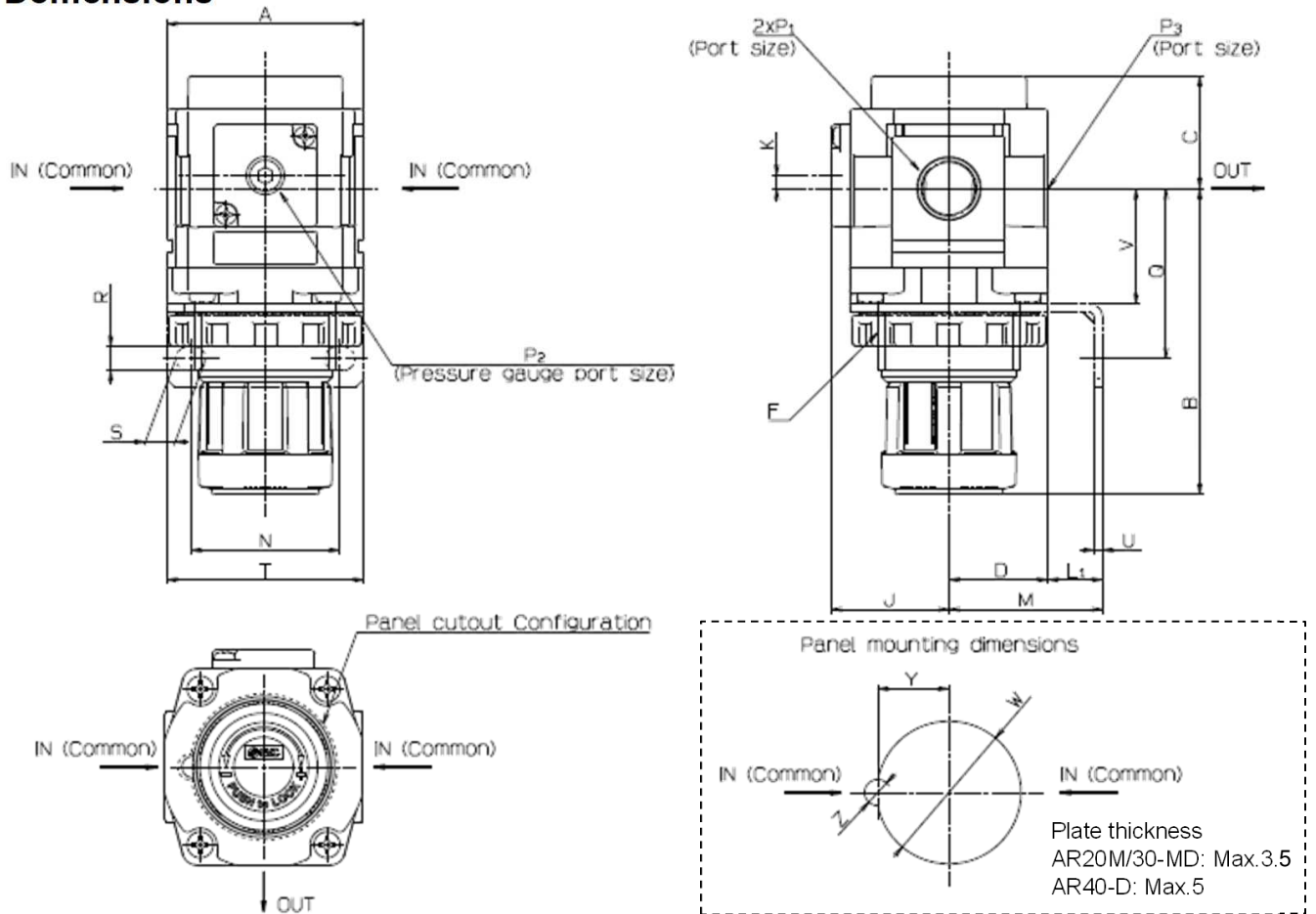

Round type pressure gauge	Square embedded type pressure gauge	Right angle square type pressure gauge	Digital pressure switch

## Dimensions

Model	Standard specifications											Optional specifications					
	$P_1$	$P_2$	$P_3$	A	B <sup>Note 1)</sup>	C	D	F	J	K	$L_1$	H	J	H	J	H	J
AR20M-D	1/8·1/4	1/8	1/8·1/4	40	66.8	26.5	21	M28X1	26	2	9	φ37.5	62.5	φ37.5	63.5	φ37.5	63.5
AR30M-D	1/4·3/8	1/8	1/4	53	86.5	30.5	26.5	M38X1.5	31.5	3.5	14.5	φ37.5	68	φ37.5	69	φ37.5	69
AR40M-D	3/8·1/2	1/8	1/4·3/8	70	91.5	35.5	35.5	M42X1.5	40.5	0	14.5	φ42.5	78	φ42.5	78	φ42.5	78

Model	Optional specifications					Optional specifications												
	Square embedded type pressure gauge		Right angle square type pressure gauge		Digital pressure switch	Bracket mount									Panel mount <sup>Note 2)</sup>			
	H	J	H	J	H	J	M	N	Q	R	S	T	U	V	W	Y	Z	
AR20M-D	□28	27	□28	54.3	□27.8	37.5	30	34	43.9	5.4	15.4	55	2.3	24.7	28.5	14	6	
AR30M-D	□28	33	□28	59.8	□27.8	43	41	40	46	6.5	8	53	2.3	31.3	38.5	19	7	
AR40M-D	□28	42	□28	68.8	□27.8	52	50	54	54	8.5	10.5	70	2.3	35.5	42.5	21	7	

Note 1) The dimension of B is the length when the regulator knob is unlocked.

Note 2) Panel cutout dimensions in the table indicate the dimensions for panel mounting a single regulator.

Revision history

A Right angle square type pressure gauge  
Added.

Apr. 2022.

# SMC Corporation

4-14-1, Sotokanda, Chiyoda-ku, Tokyo 101-0021 JAPAN

Tel: + 81 3 5207 8249 Fax: +81 3 5298 5362

URL <https://www.smcworld.com>

---

Note: Specifications are subject to change without prior notice and any obligation on the part of the manufacturer.  
© 2019 SMC Corporation All Rights Reserved