



Operation Manual

PRODUCT NAME

Air-Cooled Aftercooler

MODEL / SERIES

HAA7
HAA15
HAA22
HAA37

This manual is intended to explain the installation and operation of the product. Only people who understand the basic operation of the product, or have basic knowledge and ability to handle industrial machinery, are allowed to work on the product.

© 2020 SMC CORPORATION All Rights Reserved.

SMC Corporation

To Customers

Thank you for selecting SMC Air-Cooled Aftercooler.

For safety and long life of the product, be sure to read this Operation Manual (hereinafter referred to as the “manual”) and clearly understand the contents.

- The instructions described in this manual must be followed in addition to ISO 4414*1) and JIS B 8370*2) and other safety regulations.
 - *1) ISO4414: Pneumatic fluid power – Recommendations for the application of equipment to transmission and control systems.
 - *2) JIS B 8370: General rules for pneumatic equipment.
- This manual is intended to explain the installation and operation of the product. Only people who understand the basic operation of the product through this manual, or who install and operate industrial machinery and have basic knowledge and ability to handle such equipment, are allowed to work on the product.
- This manual and other documents attached to the product do not constitute a contract, and will not affect any existing agreements or commitments.
- It is strictly prohibited to copy this manual entirely or partially for use by a third party without prior permission from SMC.

Note: This manual is subject to change without prior notice.

Table of Contents

i. Safety Instructions	1
1. Specifications	4
2. Model No. identification mark	5
3. Working principle	5
4. Outer dimensions and descriptions of each part	6
5. Electric circuit diagram	8
6. Installation	9
7. Electrical wiring	10
8. Maintenance	11
9. Mounting accessories (option)	12
10. Trouble causes and remedies	15

i Safety Instructions



Before using the product be sure to read and understand all the important actions highlighted in this manual.

i - 1 Warning: Before using this product

This chapter is intended to specifically describe the safety related issues for handling the product.

Read this before handling the product.

- The aftercooler cools the hot pressing air to 40°C or less, and is a product that separates pycnosis as for the included moisture.SMC does not take any responsibility for any problems that may arise from using the product for other purposes.
- The product is operated at high voltage and contains components which become hot and rotate. If a component needs to be replaced or repaired, contact a specialized vendor for parts and service. All personnel who work with or around the product should read and understand the safety related information in this manual carefully before starting work.
- This manual is not a comprehensive manual covering safety and health related issues. This should be handled by a person in charge of safety training.
- All personnel who work with or around the product should have sufficient knowledge about the dangers inherent to the product and be trained in safety measures.
- The safety manager is responsible for strictly observing safety standards, but responsibility in respect to safety standards during daily work resides with each individual operator and maintenance personnel.
- The operator and maintenance personnel should consider work places and environments for each task with due consideration of safety issues.
- It is necessary to undergo appropriate general safety training before being trained about this product. Training without having sufficient knowledge about safety is very dangerous. Training must not be conducted without consideration to safety.
- This manual must be kept available to the operator whenever necessary.

i - 2 Danger, Warning and Caution

The instructions given in this manual aim to assure the safe and correct operation of the product, and to prevent injury of operators or damage to the product. These instructions are grouped into three categories, "Danger", "Warning" and "Caution", which indicate the level of hazard, damage and also the degree of emergency. All safety critical information should be carefully observed at all times.

DANGER, WARNING and CAUTION signs are in order according to severity (DANGER> WARNING> CAUTION). The signs are explained on the following page.



Danger

"Danger" indicates a hazard with a high level of risk which will result in death or serious injury if an operator performs incorrect handling during the operation and maintenance of the product or does not follow the instructions necessary to avoid it.



Warning

"Warning" indicates a hazard with a medium level of risk which will result in death or serious injury if an operator does not follow the specified procedures during the operation or maintenance of the product or does not follow the instructions necessary to avoid it.



Caution

"Caution" indicates a hazard of a low level of risk which will result in minor and moderate injury or damage to product and equipment if an operator does not follow the specified procedures during the operation and maintenance of the product or does not follow the instructions to avoid it.

i - 3 **Warning related to electricity**

 Warning
<ul style="list-style-type: none">- There is a current supply part where high voltage that had been isolated by the cover panel hung in this product. Please do not drive this product with the cover panel removed.- Please go if you have enough knowledge and the experience when working and checking in the current supply part.

i - 4 **Hazards related to high temperatures**

 Warning
<ul style="list-style-type: none">- Since this product has parts that become hot during operation, there is a danger of burns resulting from contact with these parts. There is also a danger of burns due to residual heat after the power supply is cut. Therefore, wait until the temperature of hot parts has fallen below 50°C.

i - 5 **Hazards related to rotating objects**

 Warning
<ul style="list-style-type: none">- Since this product has parts that rotate during operation, there is a danger of injury resulting from contact with these parts.

i - 6 **Hazards related to pneumatic circuit**

 Warning
<ul style="list-style-type: none">- Be sure to check air pressure is zero before replacing the element or performing the maintenance of the auto drain.- When parts are loosened, there is a possibility of becoming rapid part unexpected accident such as shooting out and it is very dangerous when the compressed air pressure remains in the product.

i - 7 Limited warranty and Disclaimer / Compliance Requirements

The product used subject to the following “Limited warranty and Disclaimer “and “Compliance Requirements.

Read and accept them before using the product.

『Limited warranty and Disclaimer』

- (1) The warranty period of the product is 1 year in service or 1.5 years after the product is delivered. Also, the product may have specified durability, running distance or replacement parts. Please consult your nearest sales branch.
- (2) For any failure or damage reported within the warranty period which is clearly our responsibility, a replacement product or necessary parts will be provided.
This limited warranty applies only to our product independently, and not to any other damage incurred due to the failure of the product.
- (3) Prior to using SMC products, please read and understand the warranty terms and disclaimers noted in the specified catalog for the particular products.

『Compliance Requirements』

1. The use of SMC products with production equipment for the manufacture of weapons of mass destruction (WMD) or other weapon is strictly prohibited.
2. The exports of SMC products or technology from one country to another are governed by the relevant security laws and regulation of the countries involved in the transaction. Prior to the shipment of a SMC product of a SMC product to another country, assure that all local rules governing that export are known and followed.

Caution

The Product is provided use in manufacturing industries.
The product herein described is basically provided for peaceful use in manufacturing industries.
If considering using the product in other industries, consult SMC beforehand and exchange specifications or a contact if necessary.
If anything is unclear, contact your nearest sales branch.

1. Specifications

MODEL		HAA7	HAA15	HAA22	HAA37			
Rated conditions	Note 1) Air flow capacity L/min(ANR)	1000	2200	3300	5700			
	Inlet air temperature °C	70						
	Inlet air pressure MPa	0.7						
	Ambient temperature °C	32						
	Outlet air temperature °C	40						
Operatin range	Fluid	Compressed air						
	Inlet air temperature °C	5~100						
	Inlet air pressure MPa	0.05~1.0(With auto drain : 0.15~1.0)		0.05~0.97(With auto drain : 0.15~0.97)				
	Ambient temp.(humidity) °C	2~50						
	Installation location	Indoor						
Electric specifications	Power supply	1 phase 100VAC (50/60Hz)	1 phase 200VAC (50/60Hz)	1 phase 100VAC (50/60Hz)	3 phase 200VAC (50/60Hz)	3 phase 200VAC (50/60Hz)	3 phase 200VAC (50/60Hz)	
	Power consumption	50Hz	55	58	55	50	90	204
		60Hz	58	65	65	60	130	244
	Current	50Hz	0.8	0.43	0.8	0.4	0.4	2.0
		60Hz	0.81	0.46	0.9	0.35	0.45	2.0
Proof pressure MPa	1.5							
Cooling fan port size mm	255		300		400	350x2pcs		
Cooler	Aluminum plate fin tube							
Air inlet piping / Air outlet piping	Rp 3/4 Socket		1B Union		1 1/2B Union			
Port size of Drain outlet piping (With auto drain)	Rc 3/8 (Rc 3/8)			Rc 1/2 (Rc 3/8)				
Mass kg	18		24		36	55		
Painting color	Munsell N-8(White), Munsell 2.5PB5/8.5(Blue)							
Note 2) Application air compressor (kW)	7.5		15		22	37		
Thermometer (1pc:assembles)	-		●		●	●		
Note 3) Drain valve (1pc)	-		3/8B			1/2B		
Accessory Union (2pcs)	-		1B		1 1/2B			

Note 1) The data for L/min (ANR) is referring to the conditions of 68°F (20°C), 1atm . pressure & relative humidity of 65%.

Note 2) The application compressor is based on discharge fluence and discharge temperature (70°C) of the Screw type.

Note 3) The accessory must do the installation work by the customer oneself.

2. Model No. Identification Mark

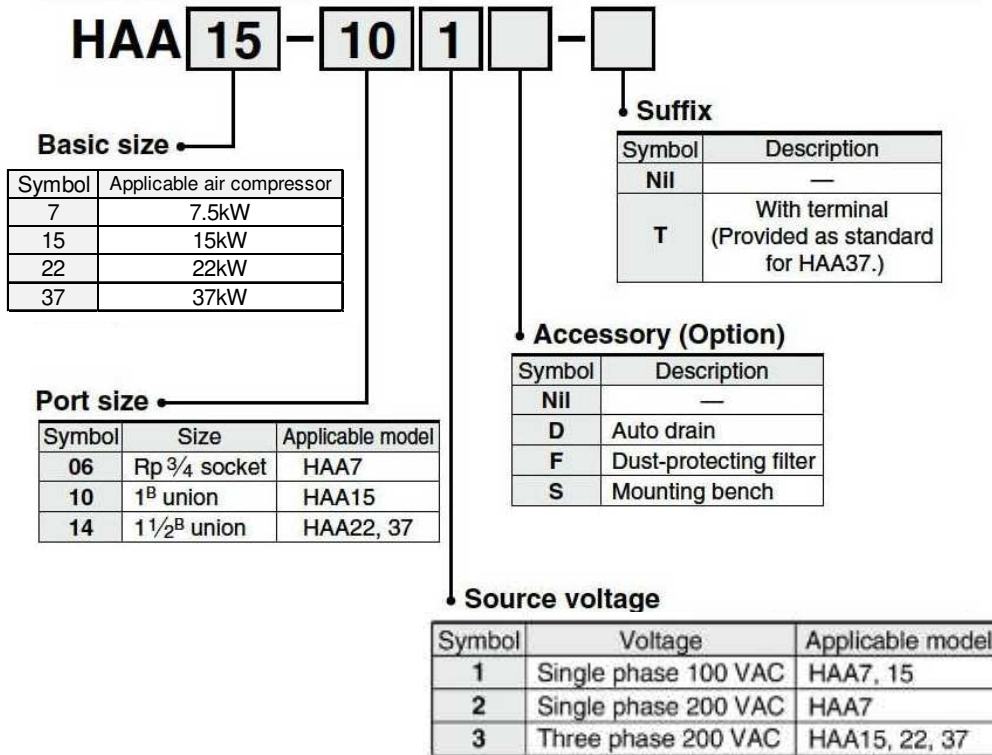

3. Working principle

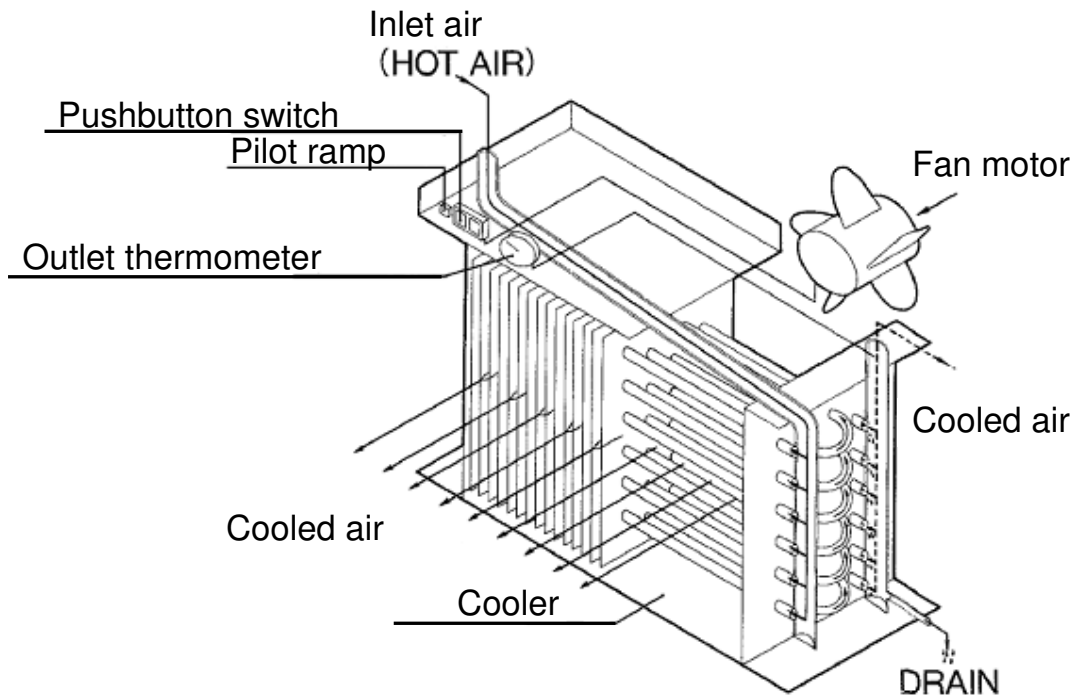

4. Outer dimensions and descriptions of each part

1) Outer dimensions

HAA7

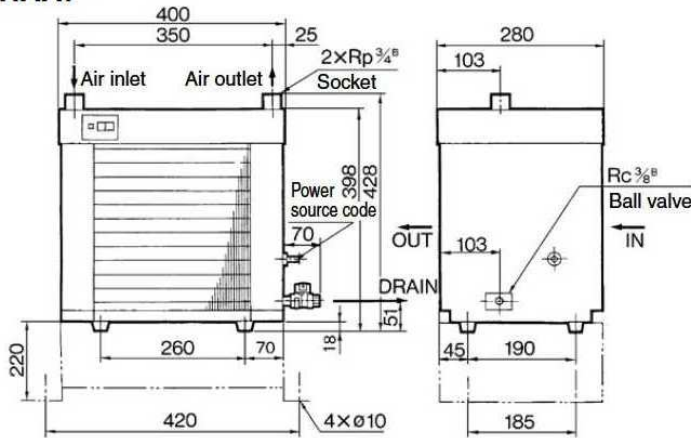

HAA15/22

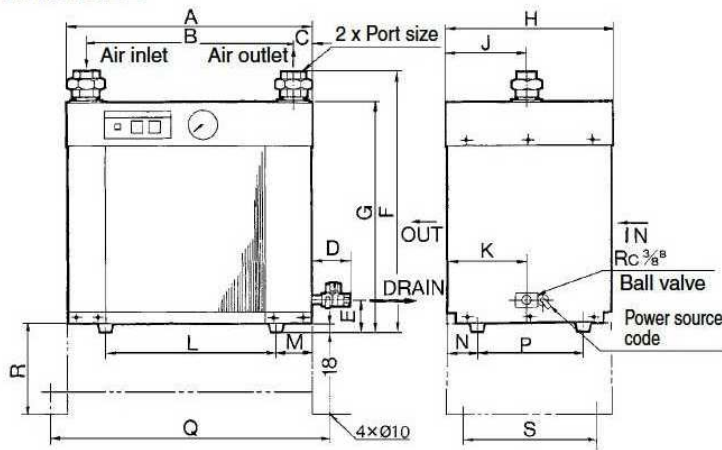

Model	HAA15-10	HAA22-14
PORT SIZE	1 ^B union	1 1/2 ^B union
A	460	588
B	394	484
C	33	52
D	70	70
E	59	60
F	485	580
G	428	505
H	320	333
J	150	150
K	150	150
L	320	400
M	70	94
N	58	65
P	200	200
Q	480	610
R	220	220
S	225	238

HAA37

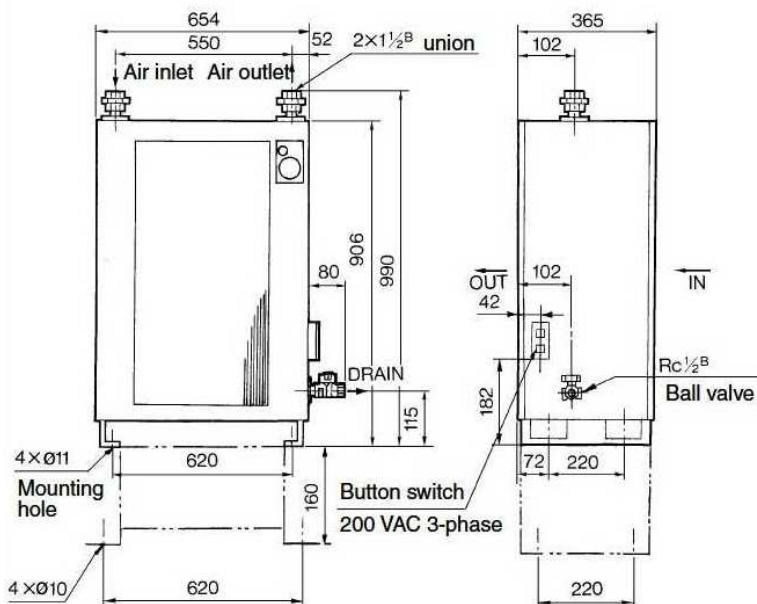

**2) Descriptions of each part
HAA7 to 22**

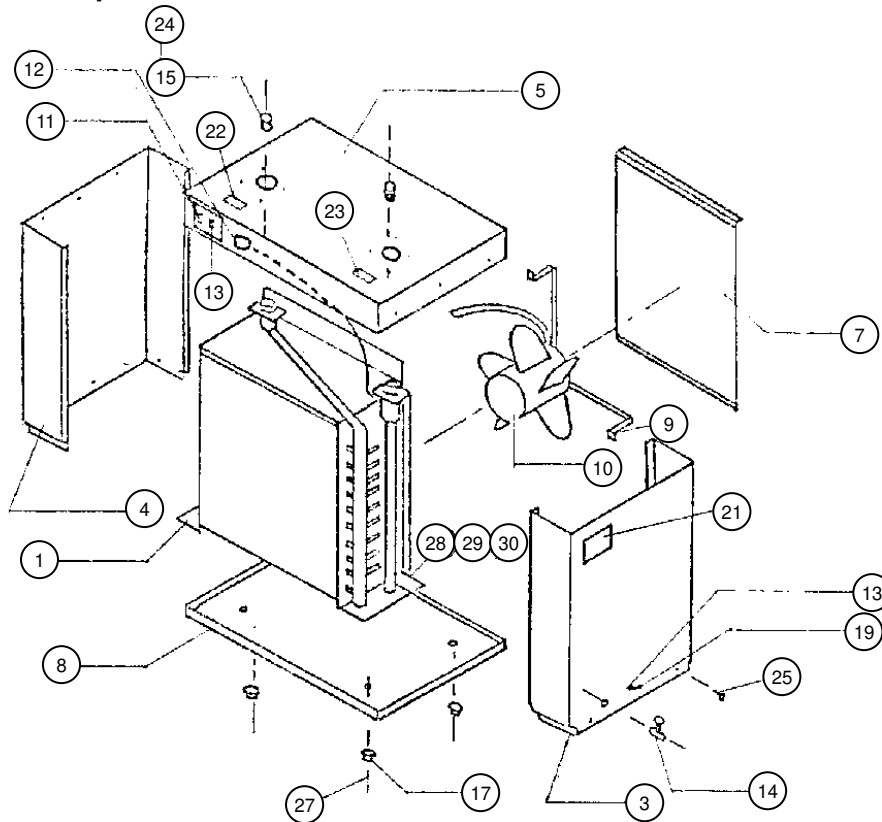

HAA37

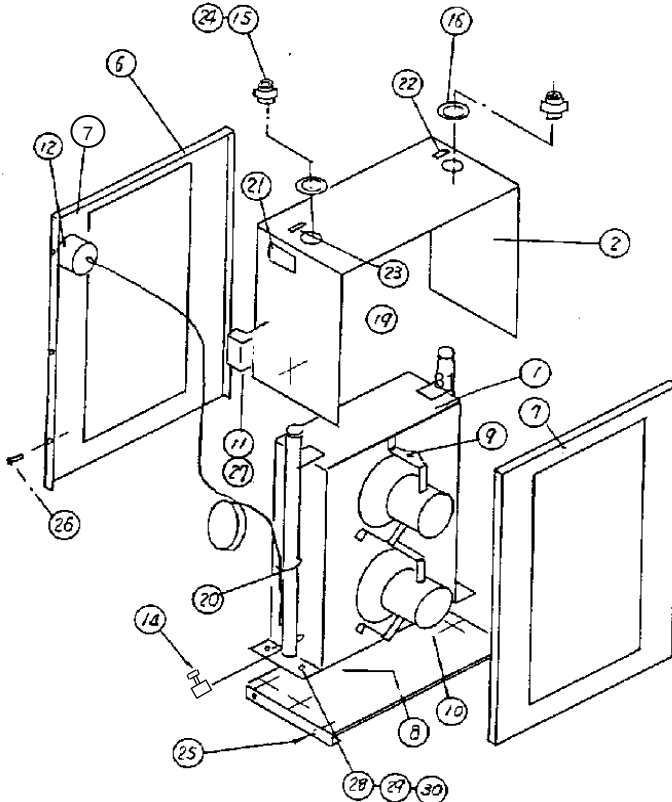

Components of aircooled aftercooler and descriptions	
No.	Description
1	Cooler
2	Main panel
3	Right side panel
4	Left side panel
5	Upper panel
6	Front panel
7	Rear panel
8	Base
9	Fan motor bracket
10	Fan motor
11	Push button switch
12	Thermometer
13	Pilot lamp
14	Drain valve
15	Union
16	Ring
17	Rubber leg
18	Rubber bush
19	Heavy-duty cord
20	Vinyl tiwrap
21	Name plate
22	IN name plate
23	OUT name plate
24	Cap
25	Cross recessed head tapping screw
26	Cross recessed head truss screw
27	Round head screw
28	Hexagon bolt
29	Flat washer
30	Spring washer
31	Plate

5. Electric circuit diagram

HAA7-061
HAA7-062

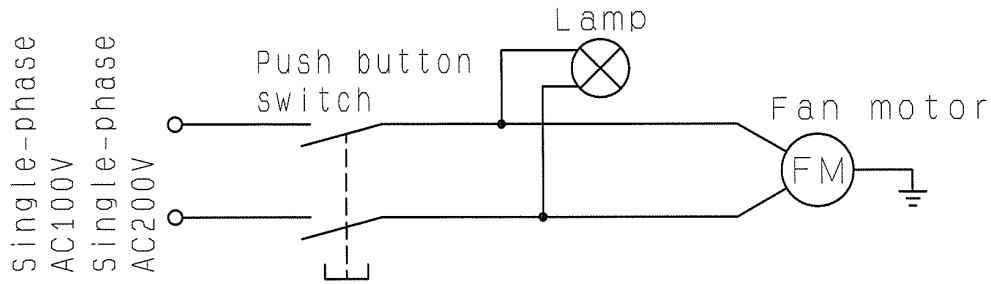

HAA15-101

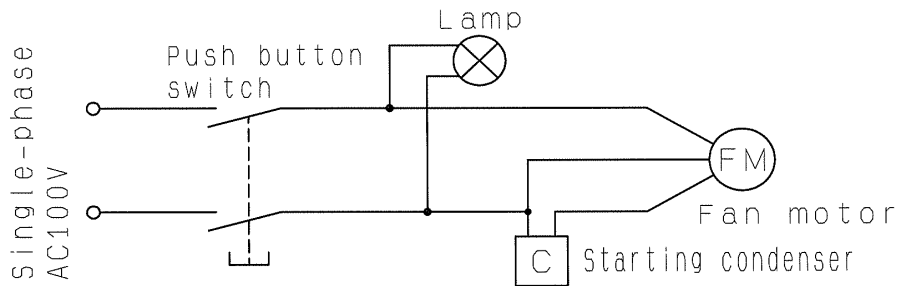

HAA15-103

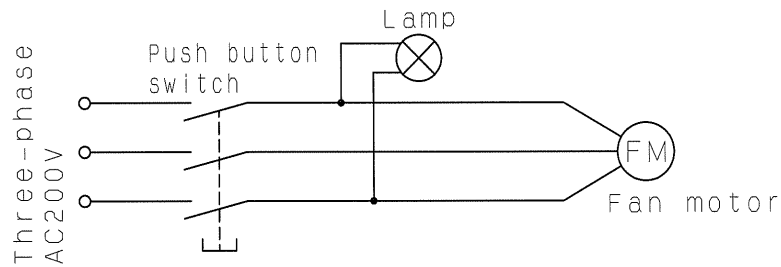

HAA22-143

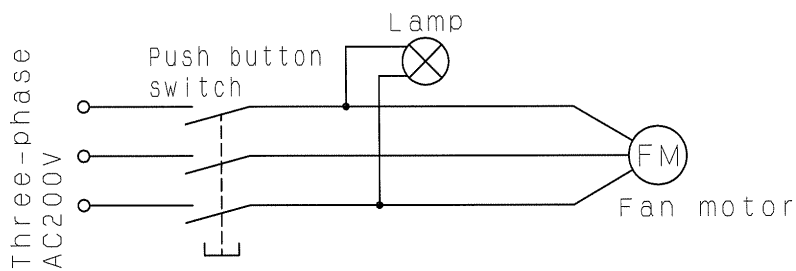

HAA37-143

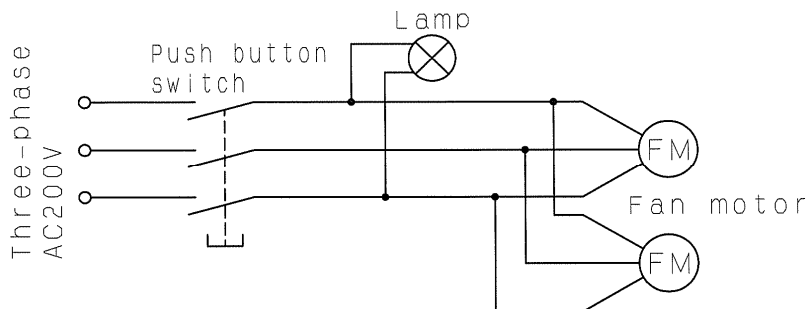

6. Installation

1) Installation Location

- (1) The unit must be installed where maintenance and installation can be made easily.
- (2) The unit must be separated from the wall and the other machines 15 to over 20cm.
- (3) The unit must be installed in an indoor place where a lot moisture and dust are not present and the unit is well ventilated.
When the unit is installed outdoors, it must be protected against wind and rain.
When the unit is used in a comparatively dusty location, it must be checked fairly frequently to make sure the condenser is not clogged, and if necessary, cleaned with a brush, air gun or cleaner, or it must be equipped with a dust prevention filter (optional) and cleaned periodically.
The unit must not be used in a place where adhesive dust (such as electrostatic coating powder and oily dust) exists. Measure, such as mounting a dust on the cooler inlet port of this unit to introduce air from the outside of the room, must be taken.
The room must be ventilated by means of a fan or other device to prevent the ambient temperature from being raised by the exhaust heat.
- (4) The temperature of the installation location must be held below 50°C.
Rated temperature is 32°C. The higher the temperature, the more will the cooling performance fall.
- (5) Avoid using the unit in such locations where atmosphere is full of corrosive gas such as sulfurous acid gas, hydrogen sulfide gas, etc.

2) Air Piping

- (1) When the compressed air from a compressor is cooled down, a lot of condensed water will be generated. Do not forget to conduct drain piping at the outlet of the drain valve.
It is recommended to use an automatic drain system for savings in labor.
When using an SMC automatic drain system, Model AD402-03D-6-A (Model AD402-04D-6-A for the Model HAA37 units), a base as shown in the following sketch, is required.
Please follow P.13 [9-3 Mounting frame of Assembly Procedure] when you use mounting frame Of the option.
- (2) The drain piping, if conducted, should have an inside diameter of at least 10mm and a maximum length of 5m. Improper piping will cause the back pressure to excessively increase at the time of draining, resulting in unstable function of the auto drain.
- (3) It is not possible to use it immediately after the compressor of reciprocating (The air temperature is 100°C or more).
In this case, we will recommend our water-cooled aftercooler.



Warning

- When draining, follow the user's own procedure to keep operators safe. (E.g. Wear protective goggles, apron and gloves to prevent contact with the drained condensate.)
 - When oils can enter the drained condensate, waste water treatment is necessary.
- Follow the bylaws or rules of the local municipality.

7. Electrical wiring



Warning

Only qualified persons are allowed to wire the product.

- Before wiring, be sure to shut off the power supply. Never perform wiring work while the product is energized.
- Ensure a stable power supply with no voltage surges.
Ensure that an ground fault circuit interrupter with appropriate capacity for ground fault and load is used in the power supply of the product to prevent electrical shock and burnout of the compressor motor.
- Use a power supply suitable for the specifications of the product.
- Be sure to connect the ground connection.
- Grounding should never be connected to a water line, gas line or lightning rod.
- Multiple wiring is dangerous because it may lead to heat generation and cause a fire.
- Do not modify the electrical wiring of the power supply.

- (1) Perform wiring firmly using heavy-duty cord with a nominal cross section of 0.75 mm² or larger and isolate it sufficiently.
- (2) HAA15-103, HAA22-143, and HAA37-143 use three phase motors.
The fan rotates backwards depending on the wiring method. Please check the rotation of the fan motor when starting the operation.
This product operates normally if air is blown out from the front face of the cooler. If the air is inhaled, perform wiring again by swapping the 2 out of 3 power supply cords on the terminal block.
- (3) Make sure to perform grounding to avoid unexpected trouble. (Such as for panel mounting screws)
- (4) Use an appropriate power supply voltage. The allowable voltage fluctuation range is +/-10% of the rated voltage.

8. Maintenance

To hold the excellent cooling capacity for a long period of time and make more effective use of the unit, the following inspection and maintenance operations must be made.

[Daily check]

- (1) Open the drain valve and remove the drainage once and a while.
- (2) When an automatic drain system is used, check once and a while to see that drainage is discharged. When the humidity is low or the compressor is run for a short time period, drain may not be produced.

[Monthly check]

- (1) The wire gauzes in the cooler section and for the motor fan and rear panel must be cleaned by means of an air gun or other device to prevent clogging.

[Annual check]

Use the unit for a long period of time allows dust and dirt containing oil and other substance to deposit on the cooler section, the motor fan section and the rear panel, lowering the cooling capacity.

To prevent this, when the accessory thermometer is over 40°C, disassemble and clean the unit by following procedure.

- (1) Turn off main power switch.
- (2) Loosen the taping screws fixed to the panel and remove the panel.
- (3) When the cooler section cannot be cleaned by use of an air gun, use chemical cleaning agent or a cleaning machine (such as steam cleaner and jet cleaner).
- (4) After drying the unit, assemble by reversing the disassembling procedure.



Danger

- During drainage work, follow your own procedure to ensure the safety of operators (e.g. wear protective goggles, apron and gloves).



Danger

- There is a risk of touching drained waste liquid during replacement.
When draining, follow the user's own procedure to keep operators safe.
(E.g. Wear protective goggles, apron and gloves to prevent contact with the drained condensate.)



Danger

- If the drained fluid contains oil, waste liquid treatment is necessary according to local laws or regulations.



Danger

- Be sure to check air pressure is zero before replacing the element or performing the maintenance of the auto drain.

9. Mounting accessories (option)

Please assemble the option (accessories) with the following points.

1) Terminal Assembly (Symbol: T)

- (1) Mount the rubber sheet on the side panel and stick it to the location where the hole and hole of rubber sheet match.
- (2) Cut off the power cord 80mm away from the grommet.
- (3) Process the end of the power cord as shown below and attach a crimped terminal.(TMEN1.25-3)
- (4) Fix the terminals to the side panel by pan head screws as shown below. (M4X15, SW)
- (5) Connect the power cord to the terminals.
- (6) Mount the terminal box to the side panel.

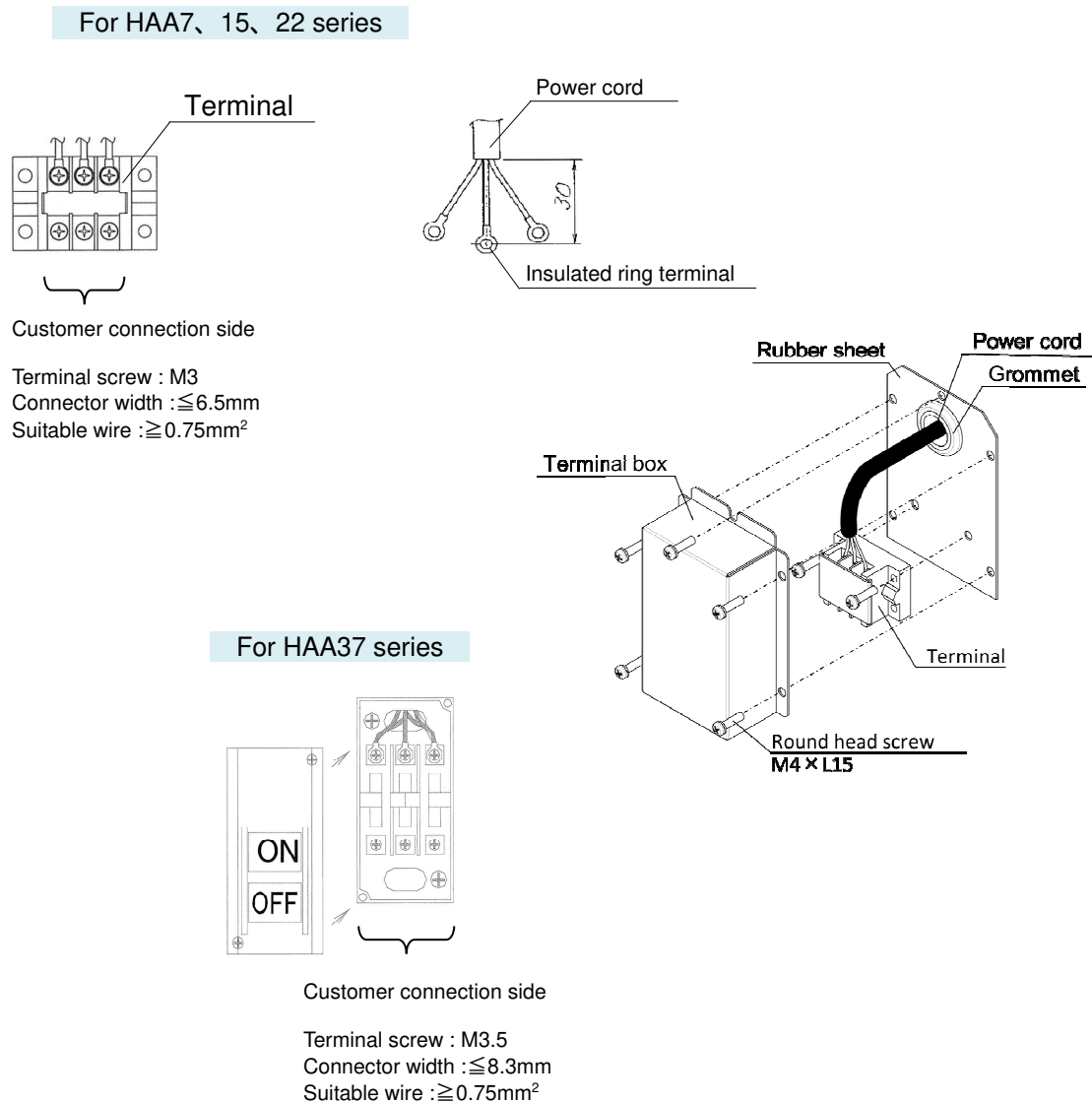

2) Auto drain Assembly (Option Symbol: D)

- (1) Mount a nipple with sealant and an auto drain onto the drain valve.
- * When auto drain is used, put the after cooler body onto a mounting bench.

If Option S has not been ordered, it can be provided as a separately sold part.

Recommended mounting frame number

Applicable model	HAA7	HAA15	HAA22	HAA37
Moumting frame number	HAA7-S	HAA15-S	HAA22-S	HAA37-S

Auto drain replacement part number

Applicable model	HAA7	HAA15	HAA22	HAA37
Auto drain part number	AD402-03D-6-A			AD402-04D-6-A

3) Mounting frame of Assembly Procedure (Option Symbol: S)

- (1) Remove four rubber legs from the rear of the base.
- (2) Assemble the mounting frame following the assembling procedure drawing.
- (3) Place the aftercooler on the mounting frame.
- (4) Secure the aftercooler to the mounting frame with round head screws or bolts/nuts.

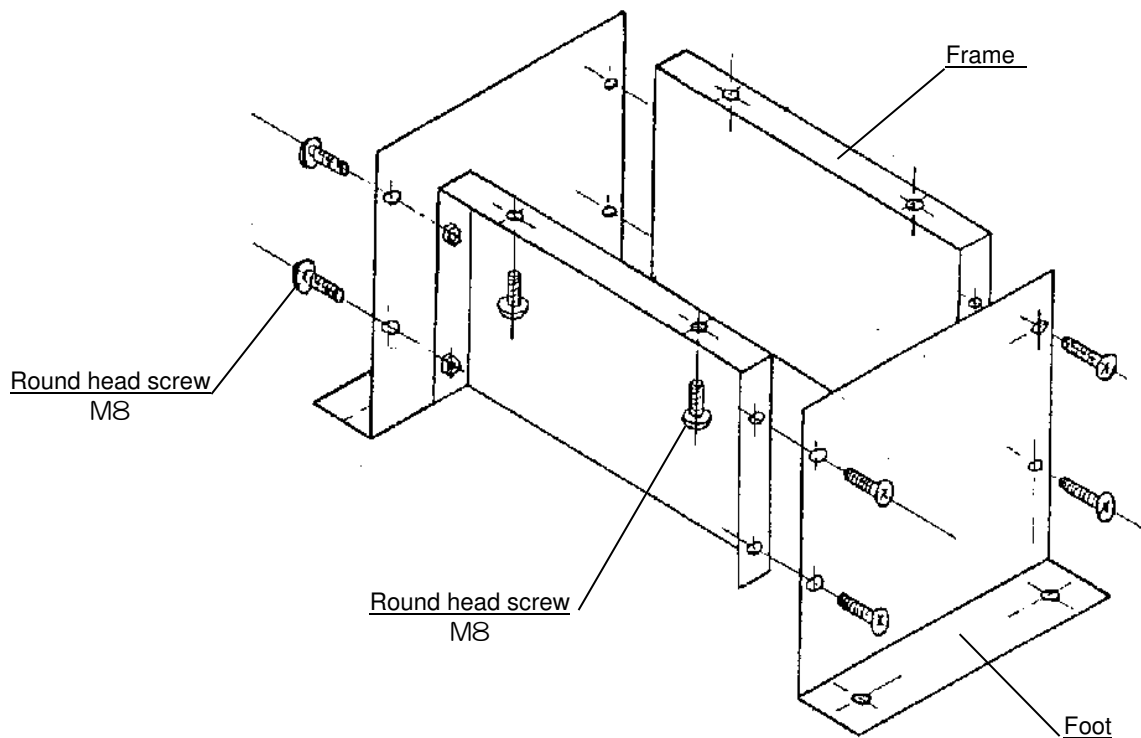

4) Dustproof filter Assembly Procedure (Option Symbol: F)

Mount a dustproof filter to the rear panel on the back of aftercooler with tapping screws as shown below.

HAA7 to HAA22

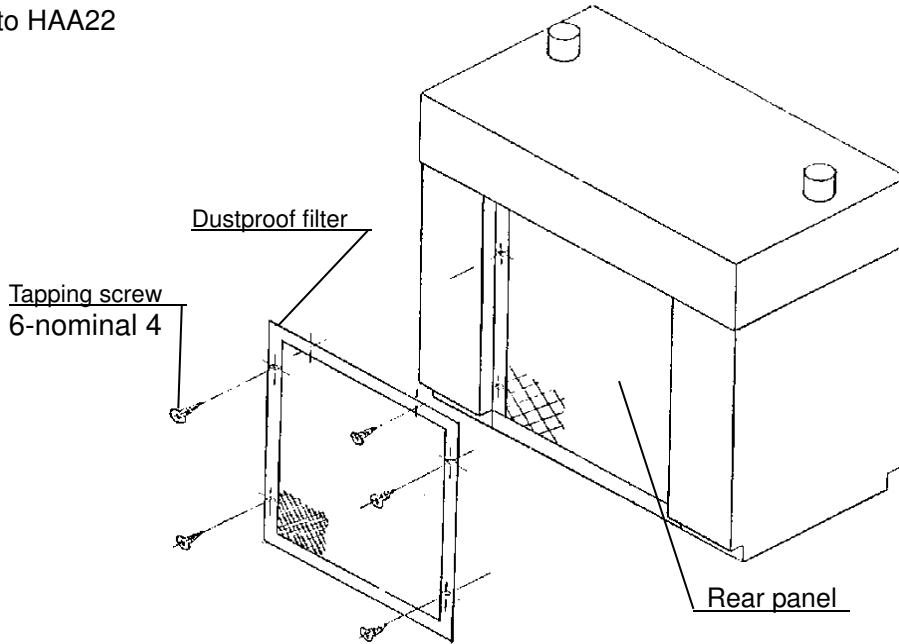

HAA37

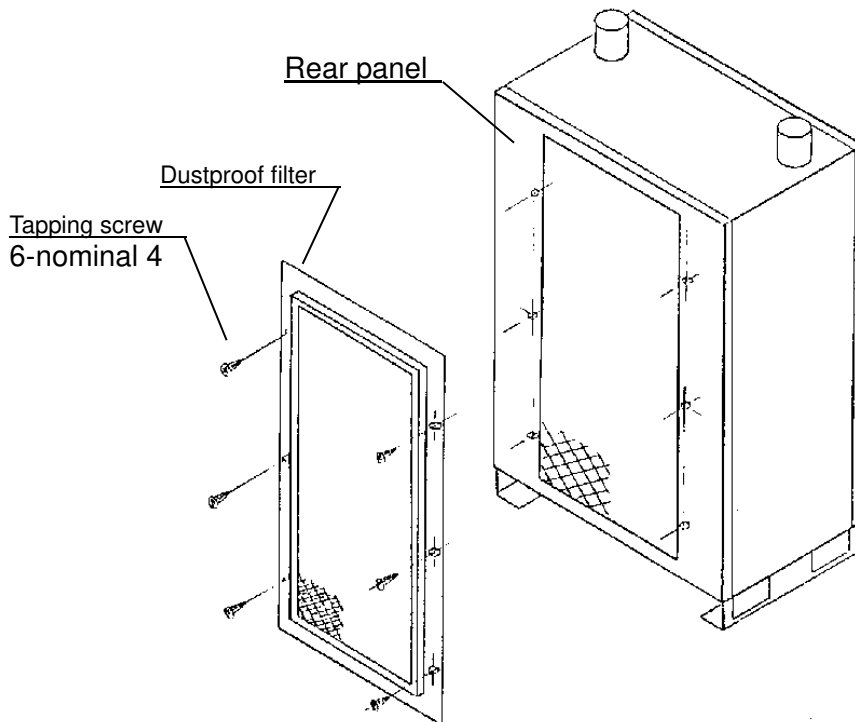

Dustproof filter replacement part number

Applicable model	HAA7	HAA15	HAA22	HAA37
Dustproof filter number	HAA7-F	HAA15-F	HAA22-F	HAA37-F

10. Trouble causes and remedies

If the unit should fail, the causes may be by those pointed out in the following chart

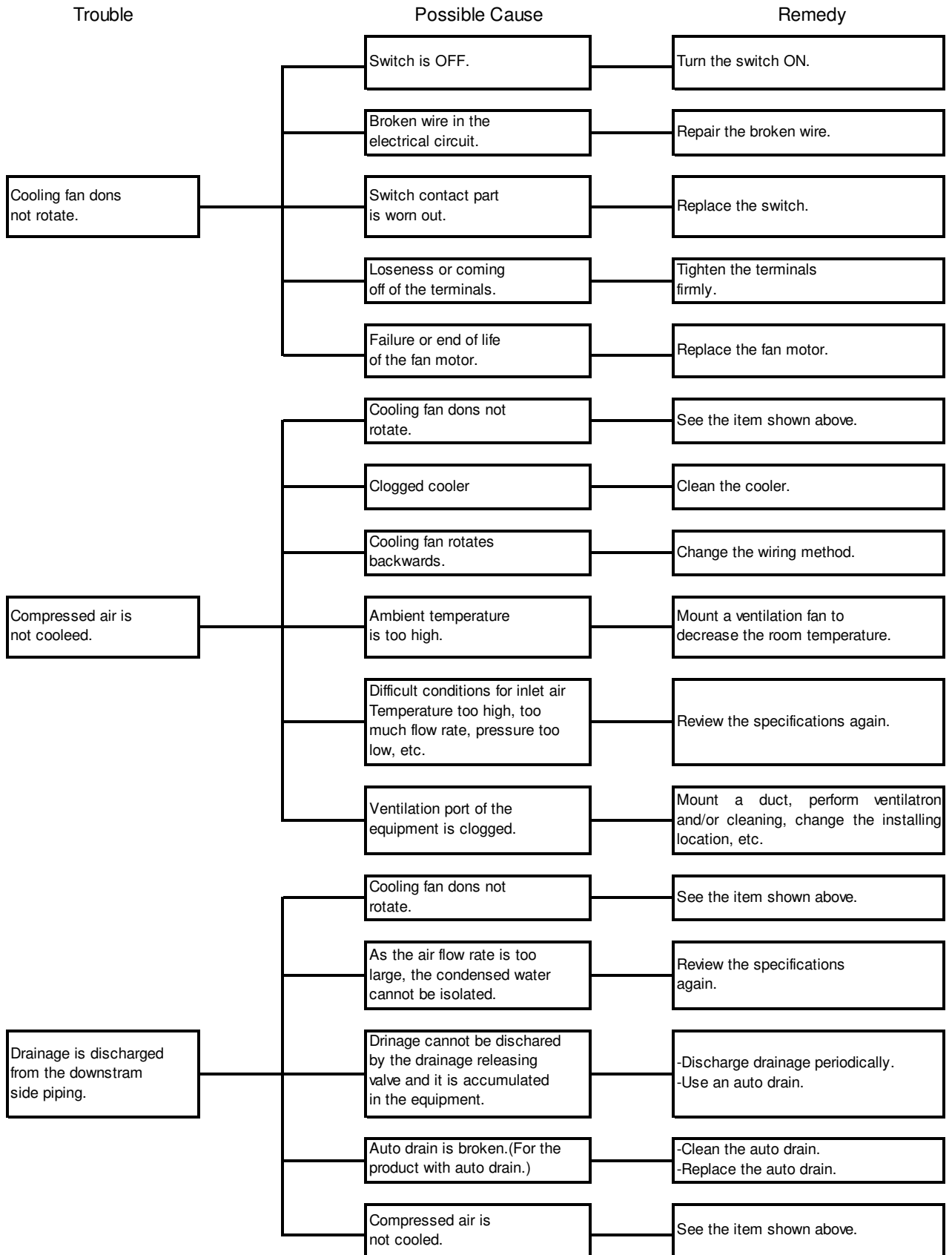

Revision
Rev. H : August 2020

SMC Corporation

4-14-1, Sotokanda, Chiyoda-ku, Tokyo 101-0021 JAPAN

Tel: + 81 3 5207 8249 Fax: +81 3 5298 5362

URL <http://www.smcworld.com>

Note: Specifications are subject to change without prior notice and any obligation on the part of the manufacturer.
© 2020 SMC Corporation All Rights Reserved