

---

# OPERATION MANUAL

---

TITLE : Rodless Cylinder  
CY3R Series

---

---

---

---

---

---

---

---

---

---

- Read this manual thoroughly before mounting and operation.
- Especially, carefully read the description concerning safety.
- Keep this manual where accessible when necessary.

---

I N D E X

---

1 . Installation to Application \_\_\_\_\_ 3

2 . Actuating Force and Moment \_\_\_\_\_ 1 0

3 . Vertical Operation \_\_\_\_\_ 1 1

4 . Immediate Stop \_\_\_\_\_ 1 2

5 . Operating Air and Piping \_\_\_\_\_ 1 3

6 . Disassembly and Maintenance \_\_\_\_\_ 1 3

7 . Other Cautions for Operation \_\_\_\_\_ 1 4

8 . Made to Order \_\_\_\_\_ 1 4

9 . Internal Construction and Parts List \_\_\_\_\_ 1 5



# Safety Instructions

These safety instructions are intended to prevent hazardous situations and/or equipment damage. These instructions indicate the level of potential hazard with the labels of "Caution," "Warning" or "Danger." They are all important notes for safety and must be followed in addition to International Standards (ISO/IEC)\*1), and other safety regulations.

\*1) ISO 4414: Pneumatic fluid power -- General rules relating to systems.

ISO 4413: Hydraulic fluid power -- General rules relating to systems.

IEC 60204-1: Safety of machinery -- Electrical equipment of machines .(Part 1: General requirements)

ISO 10218: Manipulating industrial robots -Safety.

etc.



## Caution

**Caution** indicates a hazard with a low level of risk which, if not avoided, could result in minor or moderate injury.



## Warning

**Warning** indicates a hazard with a medium level of risk which, if not avoided, could result in death or serious injury.



## Danger

**Danger** indicates a hazard with a high level of risk which, if not avoided, will result in death or serious injury.

## Warning

### 1. The compatibility of the product is the responsibility of the person who designs the equipment or decides its specifications.

Since the product specified here is used under various operating conditions, its compatibility with specific equipment must be decided by the person who designs the equipment or decides its specifications based on necessary analysis and test results.

The expected performance and safety assurance of the equipment will be the responsibility of the person who has determined its compatibility with the product.

This person should also continuously review all specifications of the product referring to its latest catalog information, with a view to giving due consideration to any possibility of equipment failure when configuring the equipment.

### 2. Only personnel with appropriate training should operate machinery and equipment.

The product specified here may become unsafe if handled incorrectly.

The assembly, operation and maintenance of machines or equipment including our products must be performed by an operator who is appropriately trained and experienced.

### 3. Do not service or attempt to remove product and machinery/equipment until safety is confirmed.

1. The inspection and maintenance of machinery/equipment should only be performed after measures to prevent falling or runaway of the driven objects have been confirmed.

2. When the product is to be removed, confirm that the safety measures as mentioned above are implemented and the power from any appropriate source is cut, and read and understand the specific product precautions of all relevant products carefully.

3. Before machinery/equipment is restarted, take measures to prevent unexpected operation and malfunction.

### 4. Contact SMC beforehand and take special consideration of safety measures if the product is to be used in any of the following conditions.

1. Conditions and environments outside of the given specifications, or use outdoors or in a place exposed to direct sunlight.

2. Installation on equipment in conjunction with atomic energy, railways, air navigation, space, shipping, vehicles, military, medical treatment, combustion and recreation, or equipment in contact with food and beverages, emergency stop circuits, clutch and brake circuits in press applications, safety equipment or other applications unsuitable for the standard specifications described in the product catalog.

3. An application which could have negative effects on people, property, or animals requiring special safety analysis.

4. Use in an interlock circuit, which requires the provision of double interlock for possible failure by using a mechanical protective function, and periodical checks to confirm proper operation.



# Safety Instructions

## Caution

### 1. The product is provided for use in manufacturing industries.

The product herein described is basically provided for peaceful use in manufacturing industries.

If considering using the product in other industries, consult SMC beforehand and exchange specifications or a contract if necessary.

If anything is unclear, contact your nearest sales branch.

## Limited warranty and Disclaimer/Compliance Requirements

The product used is subject to the following “Limited warranty and Disclaimer” and “Compliance Requirements”.

Read and accept them before using the product.

### Limited warranty and Disclaimer

#### 1. The warranty period of the product is 1 year in service or 1.5 years after the product is delivered, whichever is first.\*2)

Also, the product may have specified durability, running distance or replacement parts. Please consult your nearest sales branch.

#### 2. For any failure or damage reported within the warranty period which is clearly our responsibility, a replacement product or necessary parts will be provided.

This limited warranty applies only to our product independently, and not to any other damage incurred due to the failure of the product.

#### 3. Prior to using SMC products, please read and understand the warranty terms and disclaimers noted in the specified catalog for the particular products.

##### \*2) Vacuum pads are excluded from this 1 year warranty.

A vacuum pad is a consumable part, so it is warranted for a year after it is delivered.

Also, even within the warranty period, the wear of a product due to the use of the vacuum pad or failure due to the deterioration of rubber material are not covered by the limited warranty.

### Compliance Requirements

#### 1. The use of SMC products with production equipment for the manufacture of weapons of mass destruction(WMD) or any other weapon is strictly prohibited.

#### 2. The exports of SMC products or technology from one country to another are governed by the relevant security laws and regulation of the countries involved in the transaction. Prior to the shipment of a SMC product to another country, assure that all local rules governing that export are known and followed.

## Caution

### SMC products are not intended for use as instruments for legal metrology.

Measurement instruments that SMC manufactures or sells have not been qualified by type approval tests relevant to the metrology (measurement) laws of each country.

Therefore, SMC products cannot be used for business or certification ordained by the metrology (measurement) laws of each country.

## 1. Installation to Application

The rodless cylinder presented in this manual can operate the load directly mounted on it without other axes in a range of allowable mounted load, moment and stroke if it is equipped with the switch rail. (Table1,2) (P8,9) However, without the switch rail, the load needs to be guided by other axes (LM guide etc.) to prevent rotation of external slider and direct application of the load over the allowable range.

### 1-1) Installation of cylinder body

Before installation of cylinder body, be sure to fix end covers by bolts (to realize support at both ends).

(Fig. 1)

Also, do not use the cylinder with fixed at external slider to avoid excessive moment applied to bearing of the cylinder.

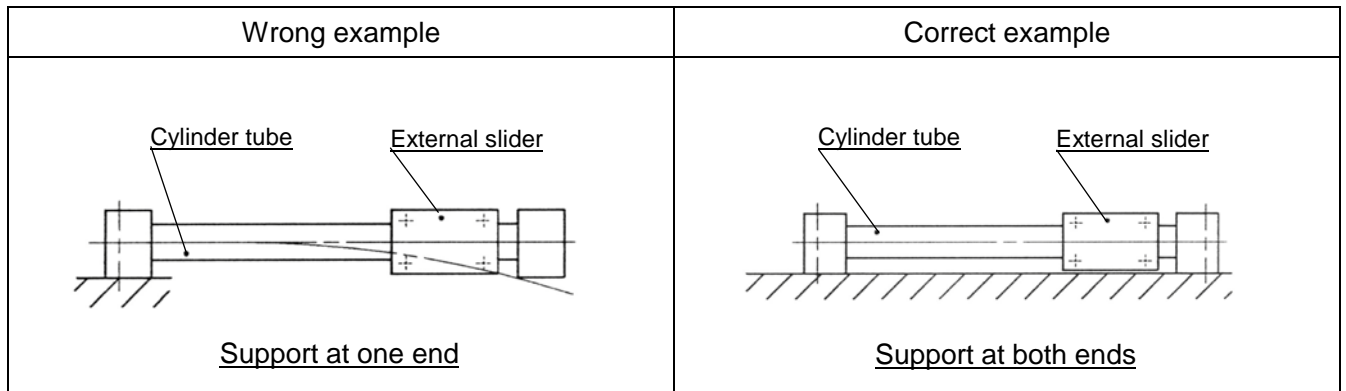

Fig. 1 Installation of cylinder body

### 1-2-1) Installation of cylinder body

There are two ways to install the cylinder body as shown on Fig. 2-1 and 2-2. For each mounting face and place, tighten the bolt on the top and bottom faces properly to make no looseness.

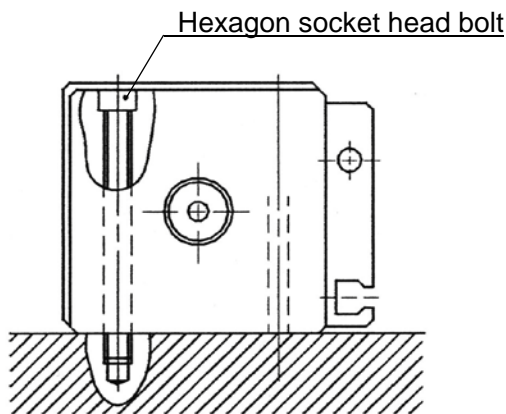

Fig. 2-1 Tightening to top face

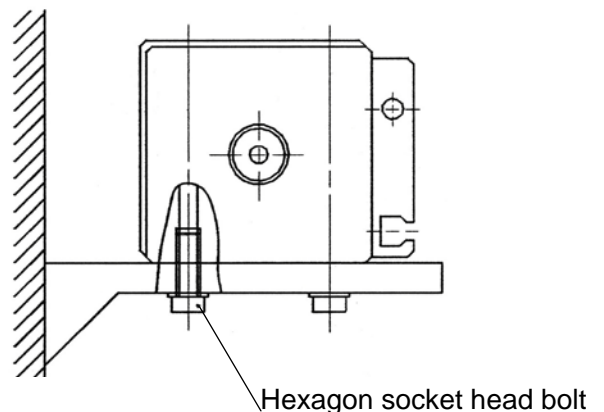

Fig. 2-2 Tightening to bottom face

If tightening of the bolt creates the gap between end cover at each end and corresponding mounting face, insert spacer etc. to close the gap without excessive force given to these covers and faces by the tightening.

## 1-2) Installation of external slider and load

Same as installation of the cylinder body, there are two ways to install the external slider and load in a range of allowable mounted load, moment and stroke.

### ( I ) With other axes combined

### ( II ) Without other axes combined

(Switch rail is used as non-rotation device.)

#### ( I ) With other axes combined

Consider the following two points for mounting of external slider and load.

I -a) The cylinder is deflected by self-weight as shown on Fig. 3-1. This means longer stroke produces larger displacement of alignment.

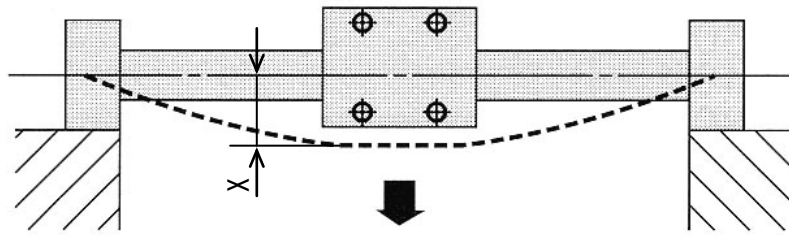

A

Fig. 3-1 Deflection of rodless cylinder by self-weight

I -b) The misalignment between cylinder body and guide (orbit) may be caused depending on machining accuracy of the space for mounting. Therefore, **the installation must be performed to compensate the misalignment.** The following two show the example with or without concern about misalignment respectively.

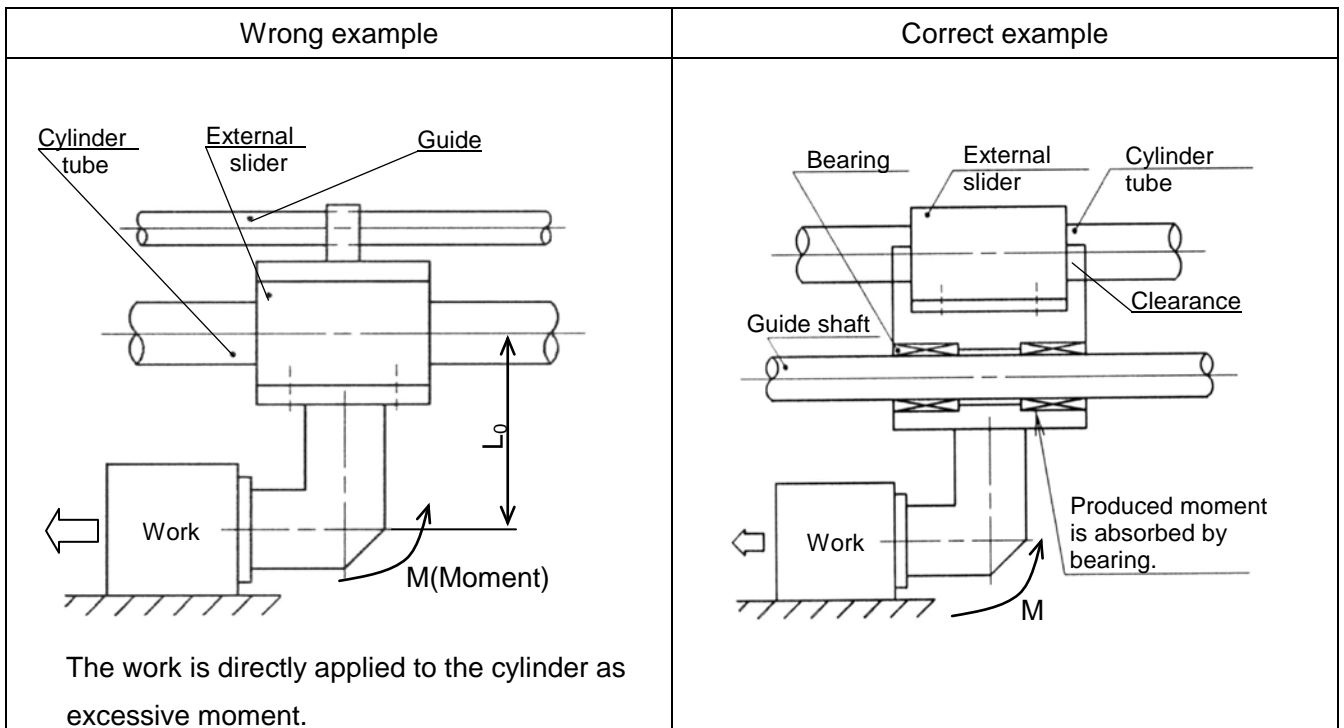

Fig. 4-1 [Ex.-1]

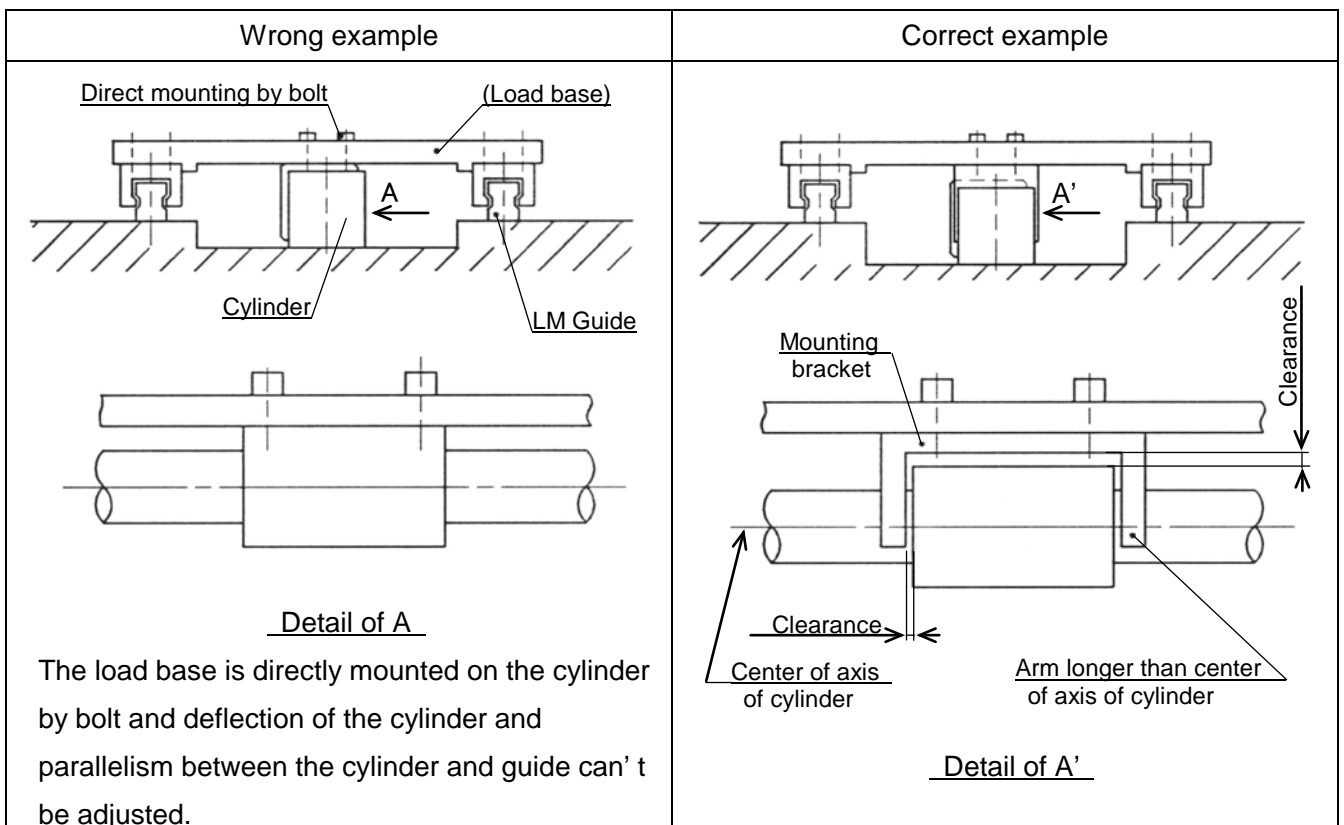

Fig. 4-2 [Ex.-2]

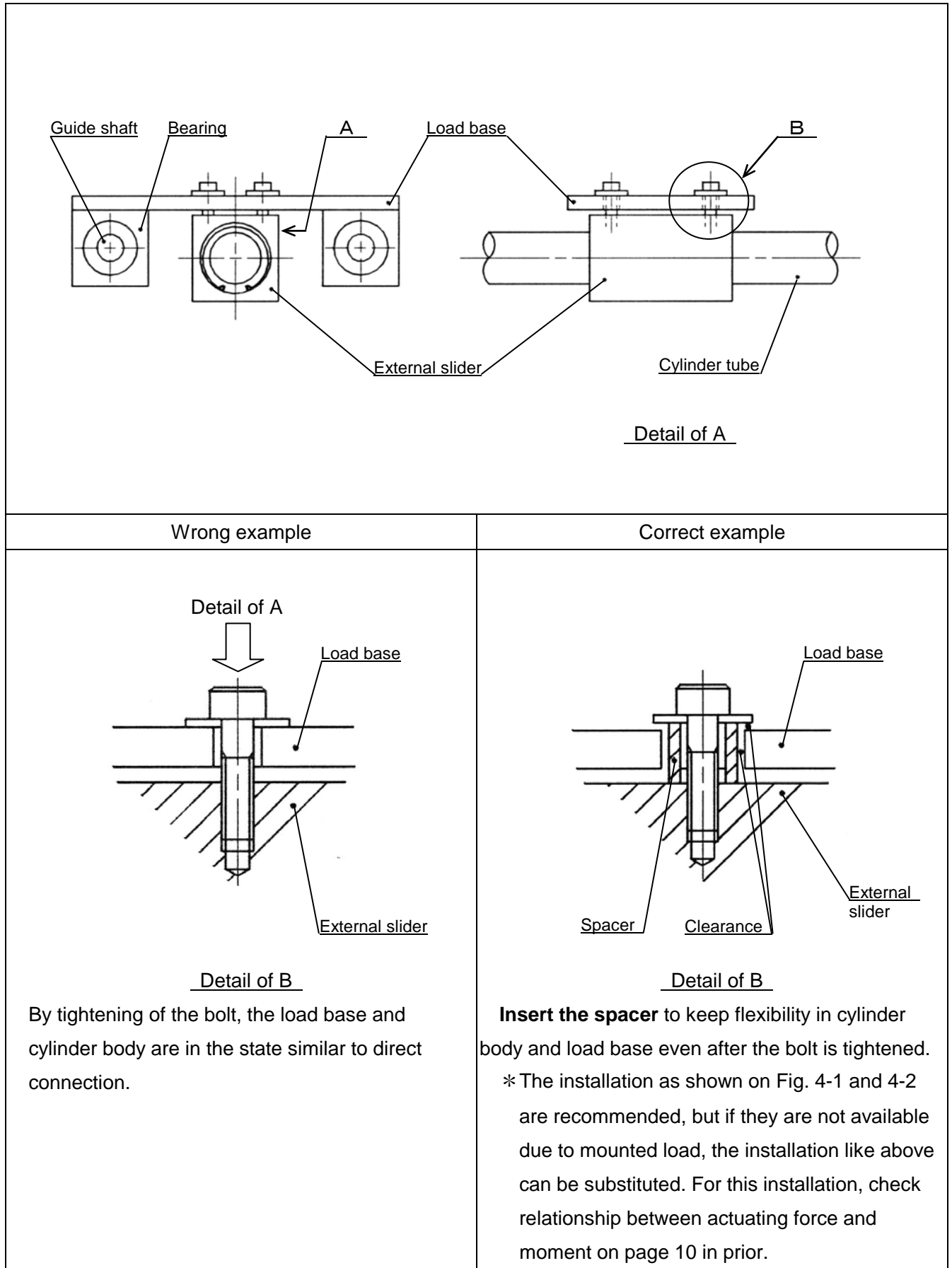

Fig. 4-3 [Ex.-3]



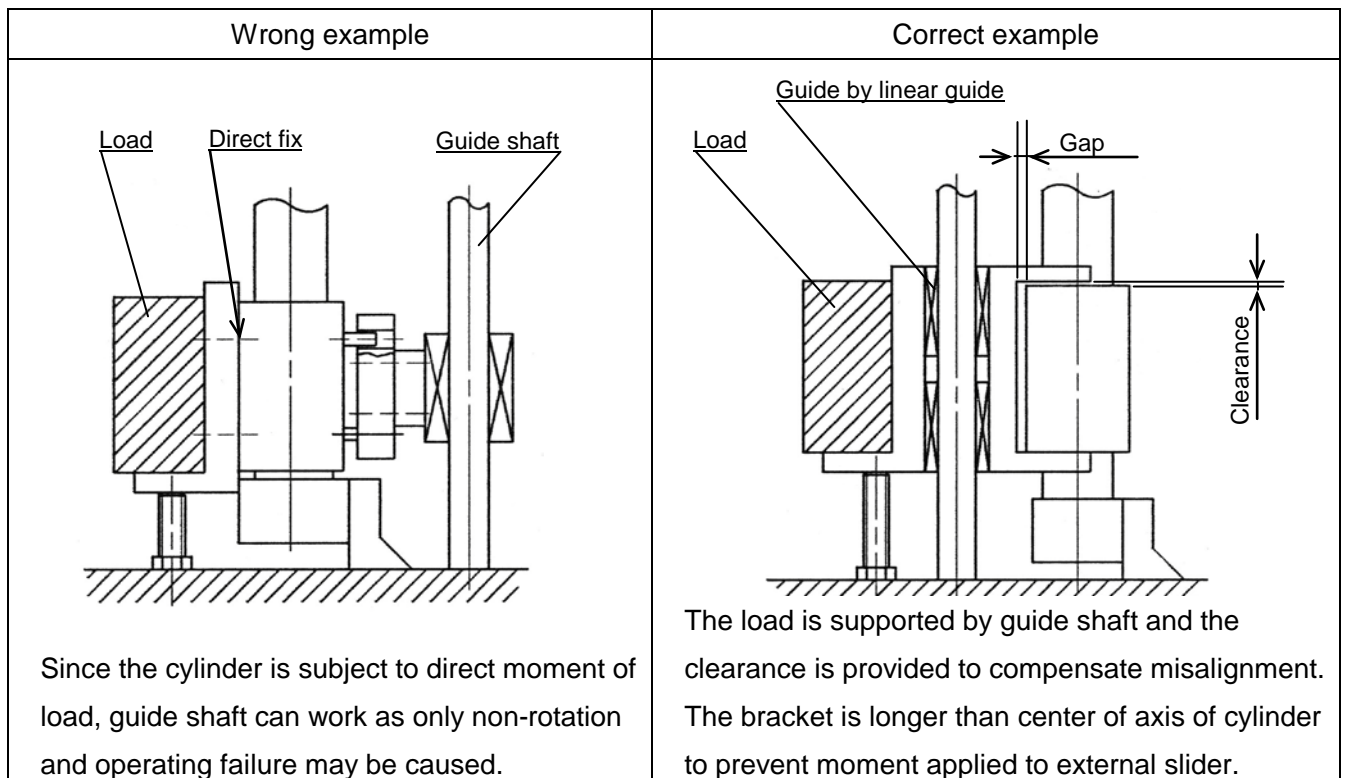

Fig.4-4 [Ex.-4]

In wrong example shown of Fig. 4-2 [Ex.-2] (with external slider mounted directly on load base), the misalignment between guide (orbit) and cylinder is not compensated and may induce operating failure. To eliminate the misalignment and deflection of cylinder by self-weight, clearance is provided between mounting bracket and cylinder as shown on correct example. Additionally, **the mounting bracket should be longer than center of axis of cylinder** to minimize the moment applied to the external slider.

If the cylinder is mounted as shown on wrong example from Ex.1 to 4, external slider clamped is cylinder tube strongly during operation and the wearing is worn so much as to cause operating failure.

As alternative solution for misalignment between cylinder and load, the rodless cylinder with specific bracket (floating joint) is also by addition of -XC57 to suffix of part no. (Fig. 4-5) However, the floating joint block obtained by -XC57 can't be mounted to standard cylinder because -XC57 is adopting specific external slider. Therefore, if -XC57 spec. is required for standard cylinder purchased independently, the cylinder needs to be sent to SMC factory for repair with description of request "-XC57 spec."

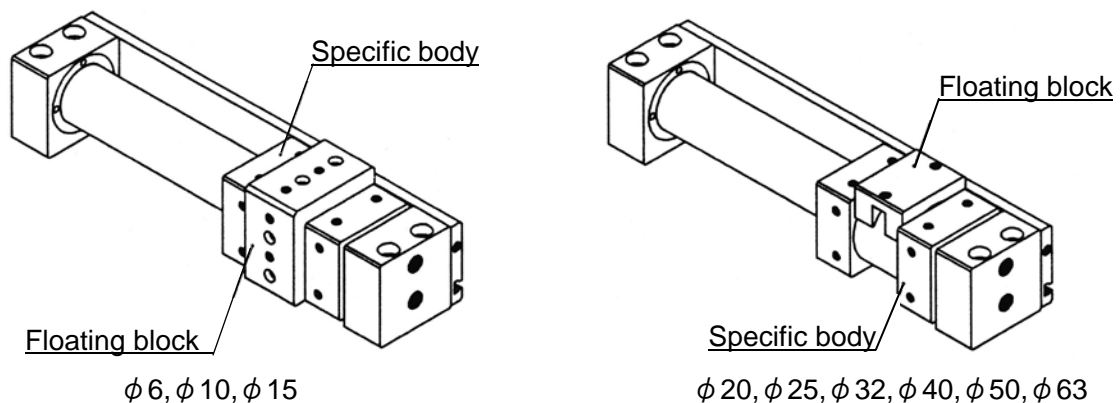

Fig. 4-5 [Ex.-5] (-XC57)

The misalignment can be checked by the following procedure.

- 1) After installation of cylinder to application, increase pressure of regulator gradually before checking operation of cylinder at operating pressure, and then calculate min. pressure which enables smooth operation of cylinder over full stroke.
- 2) The min. operating pressure obtained after mounting of load (actual min. operating pressure) is different from one of independent cylinder, but the difference should be focused.
- 3) The actual min. operating pressure is sum of "sliding resistance of cylinder", "force to operate load" and "sliding resistance of guide". (Fig. 5)

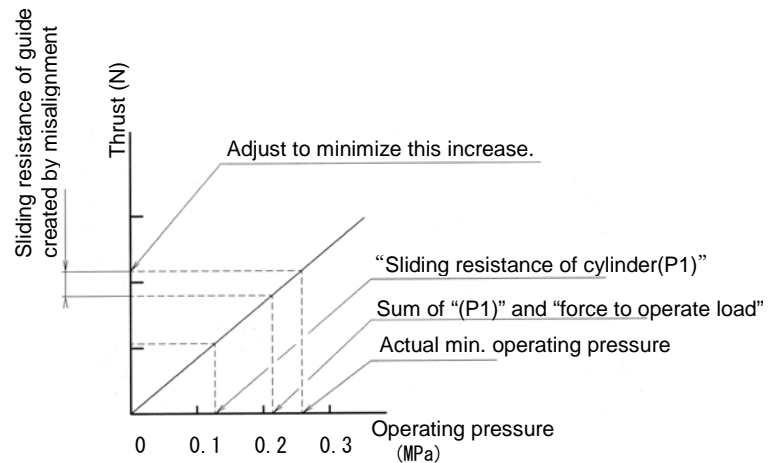

Fig. 5 (Reference)

This means when misalignment is not compensated enough, sliding resistance of guide increases excessively.

Additionally, sliding resistance of external slider increases and causes wearing to wear so much as to induce operating failure.

( II ) Without other axes combined (Switch rail is used as non-rotation device.)

If the load is mounted directly on the cylinder without other axes, ensure that weight of the load, stroke and moment are within allowable value with reference to Table 1 and 2.

If any of them exceeds corresponding allowable value, add the axis (LM guide etc.) to the cylinder.

(Fig. 4-1 to 4-4)

Table 1 Max. load weight

Cylinder tube I.D. (mm)	Max. load weight (kg)
φ 6	0.2
φ 10	0.4
φ 15	1.0
φ 20	1.1
φ 25	1.2
φ 32	1.5
φ 40	2.0
φ 50	2.5
φ 63	3.0

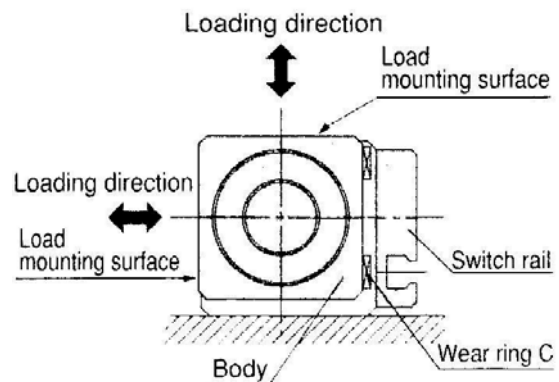

A

Table 2 Non-rotation accuracy and max. allowable moment at stroke end (reference)

Cylinder tube I.D. (mm)	Non-rotation accuracy (°)	Max. allowable moment (N · m)	Note 2) Allowable stroke
φ 6	7.3	0.02	100
φ 10	6.0	0.05	100
φ 15	4.5	0.15	200
φ 20	3.7	0.20	300
φ 25	3.7	0.25	300
φ 32	3.1	0.40	400
φ 40	2.8	0.62	400
φ 50	2.4	1.00	500
φ 63	2.2	1.37	500

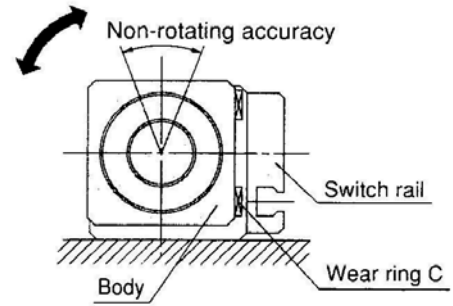

A

Fig.6-2 Non-rotation accuracy direction

- Note 1) Avoid usage where max. allowable moment is exceeded. In that case, use external guide together.
- Note 2) Above values can be kept within allowable stroke, but longer stroke may increase inclination (rotation angle) on the way of stroke.
- Note 3) The weight of the load allowable for direct mounting on the body is below max. load weight shown on Table 1.
- Note 4) For the specifications where non-rotation accuracy is critical, use LM guide etc. together.

## 2. Actuating force and moment

### 2-1) Actuating force

The actuating force of rodless cylinder is ideally equal to thrust at center of axis of piston but normally, as shown on Fig. 7-1, it is taken as  $F_n N$  at the part away from the center by  $L_o cm$ .

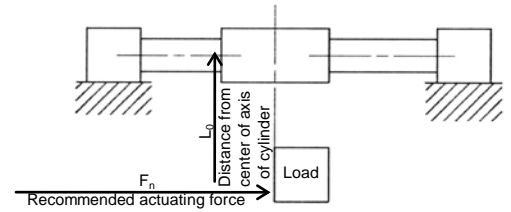

Fig. 7-1 Actuating force

The relationship between  $L_o$  and  $F_n$  can be figured from Fig. 7-2.

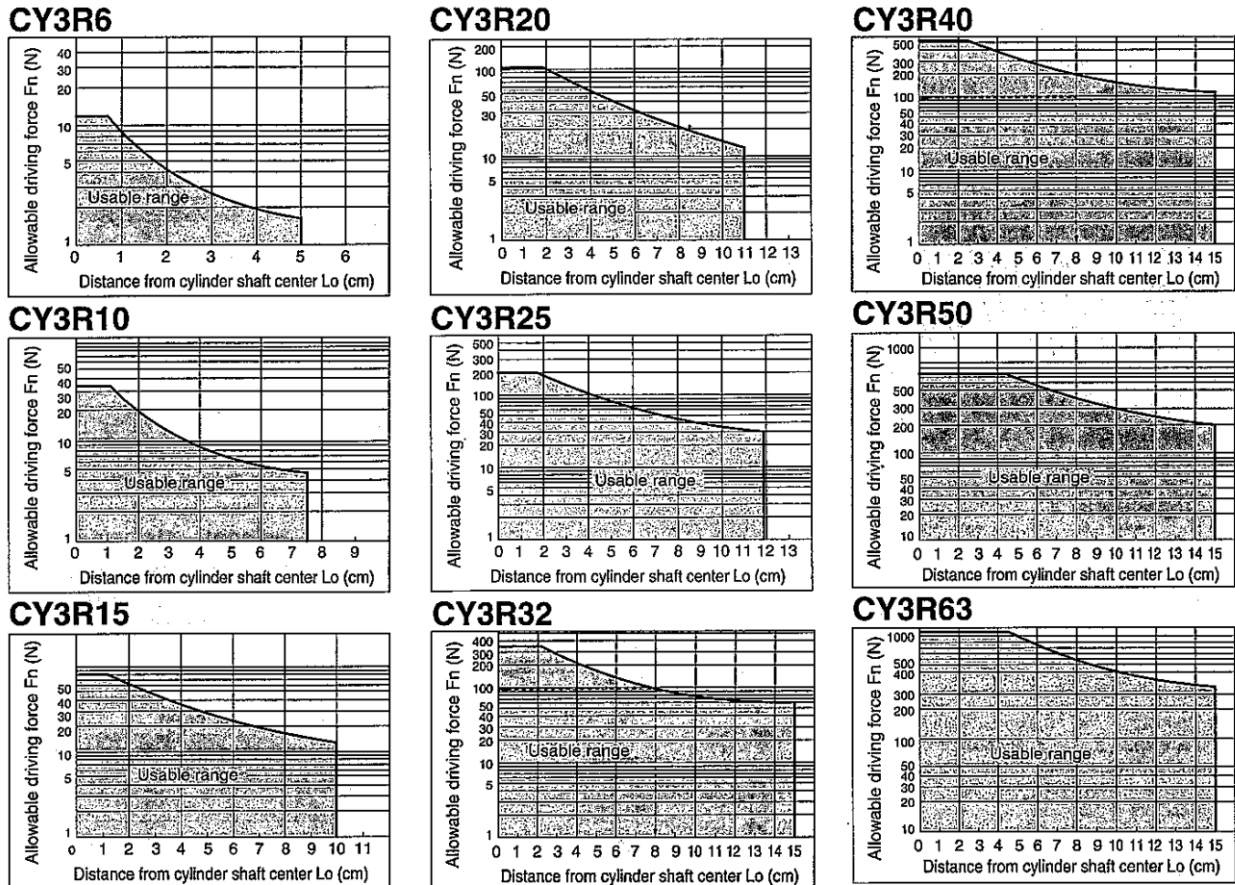

Fig. 7-2 Relationship between  $L_o$  and  $F_n$

Sizing

Ex) Sliding resistance of load : 100N

Distance between center of axis  
and point of application : 8cm

In each graph, find the point where 8 of X axis crosses with 100 of Y axis. If the point is covered with applicable operating range of the graph, the size making the graph is applicable to exemplified requirements. In this case, CY3R32 or larger are applicable.

## 2-2) Moment at stroke end

If the rodless cylinder is used for the load with large inertia, the following operating failures may be caused at stroke end.

As shown on Fig. 8-1, such a large inertial load tries to keep on linear motion on the guide though the cylinder body stops at stroke end. This produces the moment applied to the cylinder body.

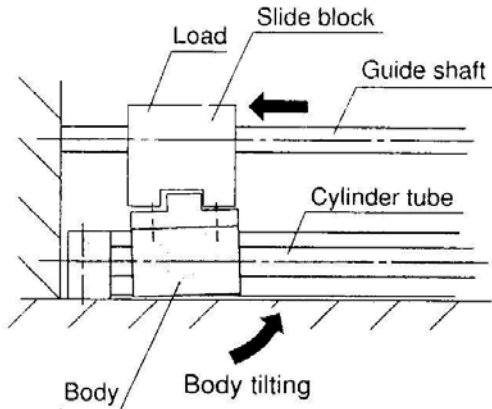

Fig. 8-1 Moment produced at stroke end

If the cylinder is kept operating in such a condition, the wearing of external slider is worn so much as to cause operating failure. To avoid occurrence of the failure, as shown on Fig. 8-2, use both of shock absorber and stopper at the mounting space for the load to absorb kinetic energy of the load and adopt the mounting bracket longer than center of axis of cylinder to prevent the moment applied to the cylinder body.

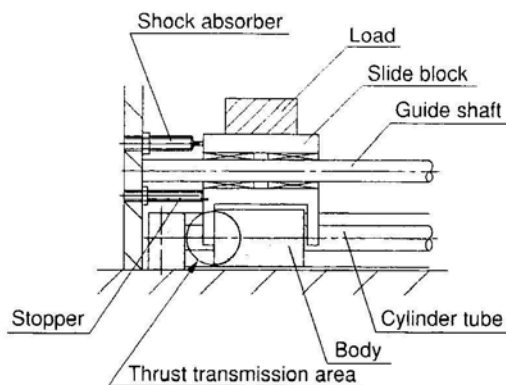

Fig. 8-2 Countermeasure for moment at stroke end

## 3. Vertical Operation

If the cylinder is operated in vertical direction, consider the same points as section 2.

### 3-1) Allowable load

Vertical operation makes the load act to holding force of magnet and allows the load less than horizontal operation.

Table 3 shows the allowable load for each size.

Table 3 Allowable load for vertical operation A

Cylinder tube I.D. (mm)	Model	Allowable load (kg)	Max. operating pressure (MPa)
φ 6	CY3R6	1.0	0.55
φ 10	CY3R10	2.7	0.55
φ 15	CY3R15	7.0	0.65
φ 20	CY3R20	11.0	0.65
φ 25	CY3R25	18.5	0.65
φ 32	CY3R32	30.0	0.65
φ 40	CY3R40	47.0	0.65
φ 50	CY3R50	75.0	0.65
φ 63	CY3R63	115.0	0.65

Note) Operation of cylinder at pressure over max. operating pressure may cause the piston to come off (drop of load).

Keep max. operating pressure

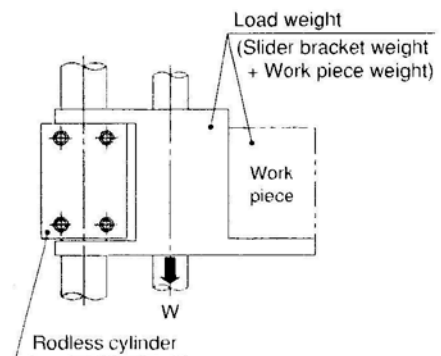

#### 4. Intermediate Stop

4-1) Consider the following point to stop the load on the way of stroke by external stopper etc.

a) Operating pressure

Keep operating pressure below the limit shown on Table 4. The operation at higher pressure may cause thrust over holding force to act and separate piston slider and external slider from each other.

Table 4 Operating pressure limit for intermediate stop

Cylinder tube I.D. (mm)	Model	Operating pressure limit (MPa)
φ 6	CY3R6	0.55
φ 10	CY3R10	0.55
φ 15	CY3R15	0.65
φ 20	CY3R20	0.65
φ 25	CY3R25	0.65
φ 32	CY3R32	0.65
φ 40	CY3R40	0.65
φ 50	CY3R50	0.65
φ 63	CY3R63	0.65

A

4-2) Consider the following points to realize intermediate stop in pneumatic circuit.

a) Intermediate stop realized by the rodless cylinder is not high accurate. If higher accuracy is required for intermediate stop, air hydraulic spec. (-X116) which combines the cylinder with air hydraulic unit is recommended.

(If it is required, contact SMC Sales division.)

b) Pay attention to kinetic energy generated by load.

If the kinetic energy generated by the load exceeds one to enable intermediate stop shown on Table 5, be concerned about possible runaway of load due to intermediate stop by closed center valve.

Table 5 Kinetic energy allowable for intermediate stop (reference)

Cylinder tube I.D. (mm)	Model	Kinetic energy (J)
φ 6	CY3R6	0.007
φ 10	CY3R10	0.03
φ 15	CY3R15	0.13
φ 20	CY3R20	0.24
φ 25	CY3R25	0.45
φ 32	CY3R32	0.88
φ 40	CY3R40	1.53
φ 50	CY3R50	3.12
φ 63	CY3R63	5.07

A

## 5. Operating Air and Piping

### 5-1) Install air filter.

The rodless cylinder is non-lubrication type. Install air filter to upstream near the valve and adjust pneumatic pressure decreased to desired set pressure by regulator.

### 5-2) Lubrication to compressed air

The rodless cylinder can be operated only by initial lubrication at shipment. But if the lubrication needs to be added due to specifications, use Turbin oil class 1 (no additive) ISO VG32. If the operation without supply of additional lubrication is required again, the cylinder needs to be sent to SMC factory to enable re-application of adequate amount of lubrication (grease).

### 5-3) For piping at both ends, change the position of plug suitable for each operating condition.

The piping port is made on axial direction of cylinder and side face, but the port on side face is plugged for shipment.

### 5-4) For common piping, remain switch rail and plug installed. Removal of these components may cause external leakage.

## 6. Disassembly and Maintenance

If the cylinder needs to be disassembled for replacement of piston packing, soft wiper and wearing, specific tool is required. The specific tool can be ordered by part no. shown on Table 6.

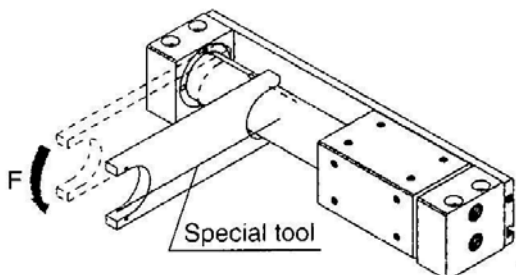

Table 6 Part no. of specific tool

Part on.	Applicable cylinder tube I.D. (mm)
CYZ-V	6,10,15,20
CYZ-W	25,32,40
CYZ-X	50
CYZ-Y	63

6-1) **If the cylinder body or piston is removed from cylinder tube, displace the positions of external slider and piston forcibly to eliminate holding force and take out them individually.** If they are removed together with holding force left, they become unable to separate from each other by internal and external magnet force.

6-2) Loosen hexagon socket head female on side of end cover by hexagon wrench, take off attachment ring from the end cover with specific tool and then remove the end cover from cylinder tube. After that, remove Circular stop ring mounted on the external face of the cylinder tube by snap ring pliers. **The used magnet has strong suction force** and should be handled with care when external slider and piston slider are removed from cylinder tube.

6-3) **Never disassembly the parts which compose the magnet (external slider and piston slider).** The disassembly of them may deprive holding force from the magnet and cause operating failure.

6-4) Take off the watch for handling of external slider and piston slider.

6-5) Handle external slider and piston slider with care to protect the magnet from drop on the floor and collision to the metal. And apply the grease periodically on external face of cylinder tube. The grease can be ordered by the following part no.

<  $\phi$  6,  $\phi$  10 >

1) Inner side of cylinder tube

GR-S-\*

0 1 0  
0 2 0

0 1 0	1 0 g
0 2 0	2 0 g

2) Outer side of cylinder tube and sliding side of switch rail

GR-F-\*

0 0 5  
0 5 0  
2 0 0  
5 0 0

0 0 5	5 g
0 5 0	5 0 g
2 0 0	2 0 0 g
5 0 0	5 0 0 g

<  $\phi$  15 ~  $\phi$  63 >

GR-S-\*

0 1 0  
0 2 0

0 1 0	1 0 g
0 2 0	2 0 g

Note) This grease is used for inner and outer side of cylinder tube.

## 7. Other Cautions for Operation

- 7-1) Some of internal components of cylinder is made of iron. Protect them from direct splash of water etc.  
If such a situation can't be avoided, contact SMC separately.
- 7-2) Before piping, perform flashing inside the piping to prevent intrusion of dust and cutting chip inside the cylinder.
- 7-3) Do not give any damage including flaw and gouge on external face of cylinder tube. These damage may be followed by the damage of soft wiper, packing and wearing and finally operating failure may be caused.

## 8. Made to Order

The made to order of the rodless cylinder is available depending on operating environment and conditions. The following shows relation between a certain operating environment or conditions and applicable type of made to order.

A

Suffix	Spec.	Operative environment and conditions	Applicable cylinder tube I.D.
-X116 (Note)	Air hydraulic	Intermediate stop accuracy higher than one obtained by pneumatic circuit is required.	$\phi 25 \sim \phi 40$
-X160 (Note)	High speed	Operation at speed higher than standard spec. is required. (Speed without load: 1500mm/s)	$\phi 20 \sim \phi 40$
-X322	With hard chrome plating on external face of cylinder tube	Wear of external wearing needs to be reduced (to improve durability of the wearing).	$\phi 15 \sim \phi 40$
-X1468	CY1B6 interchangeable specification	For request to have the same mounting dimensions as CY1B6.	$\phi 6$
-XC57	With floating joint	The time to connect cylinder with guide on other axis (load side) needs to be reduced.	$\phi 15 \sim \phi 40$

(Note) These spec. are available only in both-side piping type (CY3R) with the port in axial direction of cylinder.



## 9. Internal Construction and Parts List

### 9-1) CY3R series (both-side piping)

A

#### CY3R6

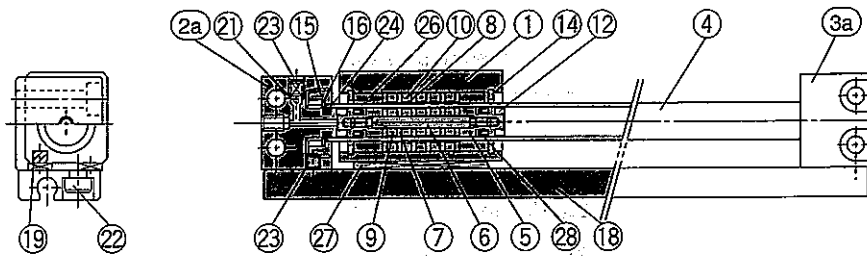

#### CY3R10

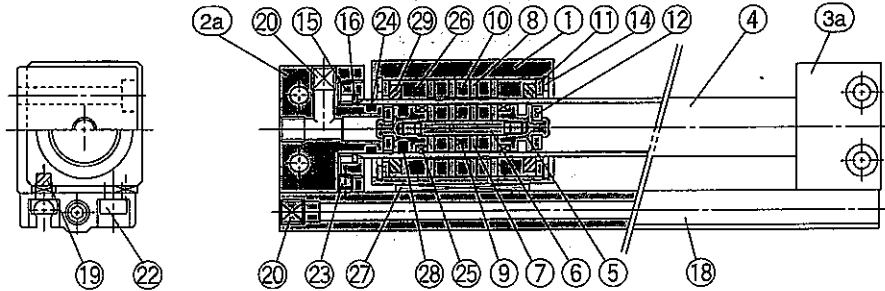

#### CY3R15 to 63

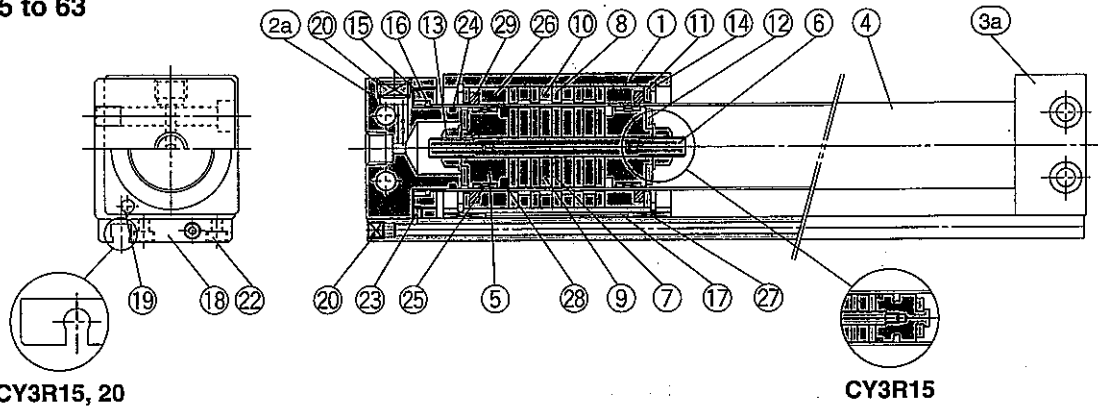

CY3R15, 20

CY3R15

#### Component Parts

No.	Description	Material	Note
1	Body	Aluminum alloy	Hard anodized
2a	End cover A	Aluminum alloy	Electroless nickel plated
2b	End cover C	Aluminum alloy	Electroless nickel plated
3a	End cover B	Aluminum alloy	Electroless nickel plated
3b	End cover D	Aluminum alloy	Electroless nickel plated
4	Cylinder tube	Stainless steel	
5	Piston	ø6 to ø15 Brass ø20 to ø63 Aluminum alloy	ø6 to ø15 Electroless nickel plated ø20 to ø63 Chromate
6	Shaft	Stainless steel	
7	Piston side yoke	Rolled steel plate	Zinc chromated
8	External slider side yoke	Rolled steel plate	Zinc chromated
9	Magnet A	Rare earth magnet	
10	Magnet B	Rare earth magnet	
11	Spacer	Aluminum alloy	Black anodized (ø6: not available)
12	Bumper	Urethane rubber	
13	Piston nut	Carbon steel	Zinc chromate (ø6 to ø15: not available)
14	C type snap ring for hole	Carbon tool steel	Nickel plated
15	Attachment ring	Aluminum alloy	Chromate
16	C type snap ring for shaft	Hard steel wire	
17	Magnetic shielding plate	Rolled steel plate	Chromated (ø6, ø10: not available)
18	Switch rail	Aluminum alloy	White anodized
19	Magnet	Rare earth magnet	
20	Hexagon socket head plug	Chromium steel	Nickel plated

No.	Description	Material	Note
21	Steel balls	Chromium steel	ø40 Hexagon socket head plug ø20, ø50, ø63 None
22	Hexagon socket head screw	Chromium steel	Nickel plated
23	Hexagon socket head set screw	Chromium steel	Nickel plated
24*	Cylinder tube Gasket	NBR	
25*	Wear ring A	Special resin	
26*	Wear ring B	Special resin	
27*	Wear ring C	Special resin	
28*	Piston seal	NBR	
29*	Lubretainer	Special resin	
30*	Switch rail gasket	NBR	Both sides piping type: None

\* Seal kits are sets consisting of numbers 24 through 30. Order using the kit number corresponding to each bore size.

#### Replacement Parts: Seal Kit

Bore size (mm)	Kit no.	Contents
6	CY3R6-PS	Numbers 24, 25, 27, 28 above
10	CY3R10-PS	Numbers 24, 25, 26, 27, 28, 29, 30 above
15	CY3R15-PS	
20	CY3R20-PS	
25	CY3R25-PS	
32	CY3R32-PS	
40	CY3R40-PS	
50	CY3R50-PS	
63	CY3R63-PS	

\* Seal kits are the same for both the both sides piping type and the centralized piping type.

9-2 CY3RG series (Common piping)

A

**CY3RG10**

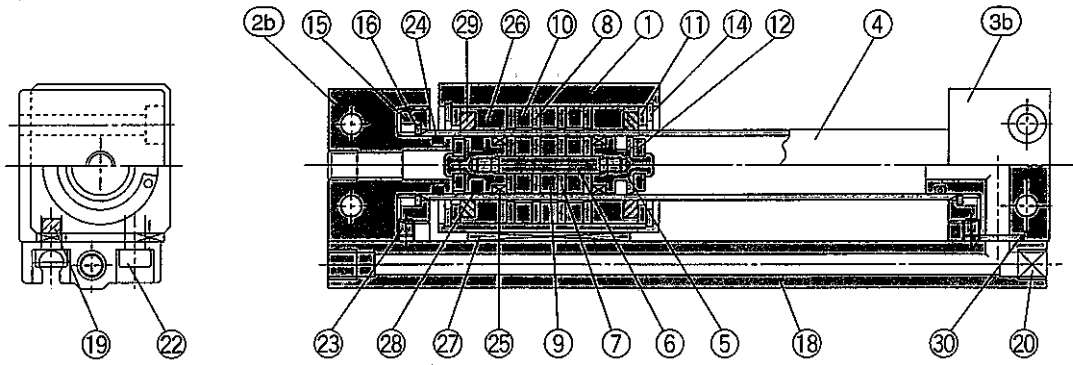

**CY3RG15 to 63**

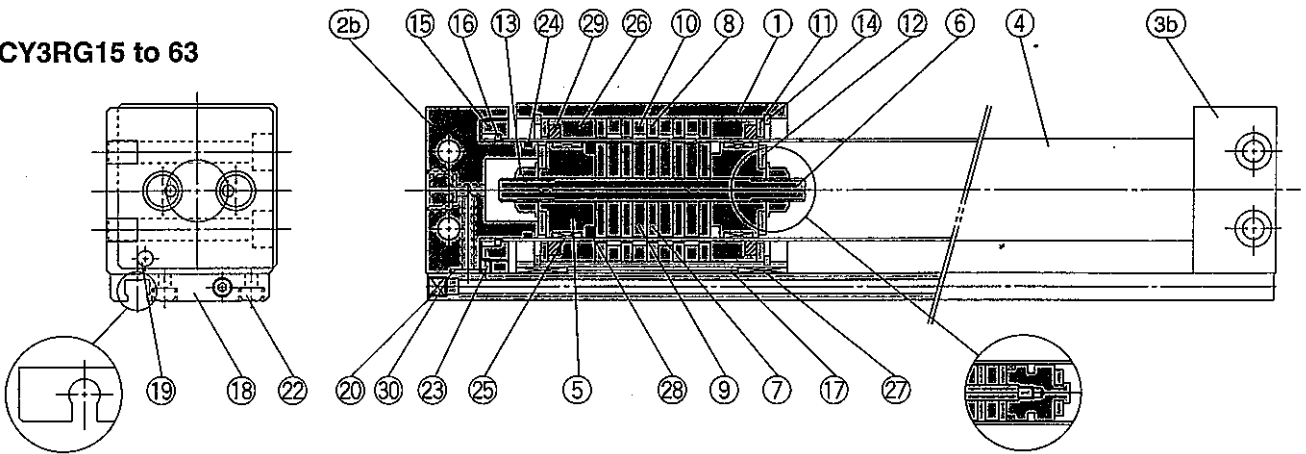

**CY3RG15, 20**

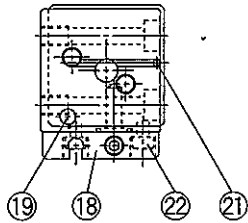

**CY3RG15**

**CY3RG15**

9-3) If the switch rail needs to be mounted to the cylinder, it can be ordered as accessory in accordance with the following numbering system.

How to order switch rail as accessory

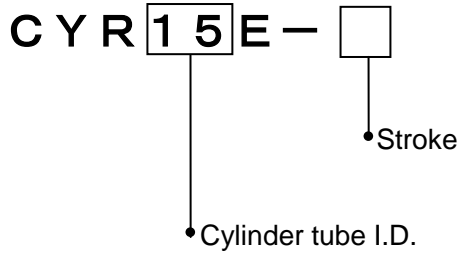

**Switch Rail Accessory Kit**

Bore size (mm)	Kit no.	Contents
6	CYR6E-□-N	Numbers ⑬, ⑭, ⑮, ⑯ on the left
10	CYR10E-□	Numbers ⑬, ⑭, ⑮, ⑯, ⑰ on the left
15	CYR15E-□	Numbers ⑰, ⑱, ⑲, ⑳, ㉑ on the left <span style="float: right;">Note 2)</span>
20	For reed switch CYR20E-□	Numbers ⑰, ⑱, ⑲, ⑳, ㉑ on the left
	For solid state switch CYR20EN-□	
25	CYR25E-□	Numbers ⑰, ⑱, ⑲, ⑳, ㉑ on the left
32	CYR32E-□	
40	CYR40E-□	
50	CYR50E-□	
63	CYR63E-□	

Note 1) □ indicates the stroke.

Note 2) A magnet is already built in for ø15.

A

Revision

# SMC Corporation

4-14-1, Sotokanda, Chiyoda-ku, Tokyo 101-0021 JAPAN

Tel: + 81 3 5207 8249 Fax: +81 3 5298 5362

URL <http://www.smcworld.com>

---

Note: Specifications are subject to change without prior notice and any obligation on the part of the manufacturer.  
© 2011 SMC Corporation All Rights Reserved