



Operation Manual

PRODUCT NAME

Speed controller with compact indicator

MODEL/ Series/ Product Number

AS-FS*A

SMC Corporation

Contents

1.Safety Instructions	3~4
2.Specific Product Precautions	5~11
3.Applications	12
4.Specifications	12
5.Malfunctions and Countermeasures	12
6.Construction	13~17



Speed controller with compact indicator

AS-FS*A Series

Safety Instructions

These safety instructions are intended to prevent hazardous situations and/or equipment damage. These instructions indicate the level of potential hazard with the labels of “Caution,” “Warning” or “Danger.” They are all important notes for safety and must be followed in addition to International Standards (ISO/IEC)*1), and other safety regulations.

*1) ISO 4414: Pneumatic fluid power -- General rules relating to systems.

ISO 4413: Hydraulic fluid power -- General rules relating to systems.

IEC 60204-1: Safety of machinery -- Electrical equipment of machines .(Part 1: General requirements)

ISO 10218: Manipulating industrial robots -Safety.

etc.



Caution

Caution indicates a hazard with a low level of risk which, if not avoided, could result in minor or moderate injury.



Warning

Warning indicates a hazard with a medium level of risk which, if not avoided, could result in death or serious injury.



Danger

Danger indicates a hazard with a high level of risk which, if not avoided, will result in death or serious injury.

Warning

1. The compatibility of the product is the responsibility of the person who designs the equipment or decides its specifications.

Since the product specified here is used under various operating conditions, its compatibility with specific equipment must be decided by the person who designs the equipment or decides its specifications based on necessary analysis and test results.

The expected performance and safety assurance of the equipment will be the responsibility of the person who has determined its compatibility with the product.

This person should also continuously review all specifications of the product referring to its latest catalog information, with a view to giving due consideration to any possibility of equipment failure when configuring the equipment.

2. Only personnel with appropriate training should operate machinery and equipment.

The product specified here may become unsafe if handled incorrectly.

The assembly, operation and maintenance of machines or equipment including our products must be performed by an operator who is appropriately trained and experienced.

3. Do not service or attempt to remove product and machinery/equipment until safety is confirmed.

1. The inspection and maintenance of machinery/equipment should only be performed after measures to prevent falling or runaway of the driven objects have been confirmed.

2. When the product is to be removed, confirm that the safety measures as mentioned above are implemented and the power from any appropriate source is cut, and read and understand the specific product precautions of all relevant products carefully.

3. Before machinery/equipment is restarted, take measures to prevent unexpected operation and malfunction.

4. Contact SMC beforehand and take special consideration of safety measures if the product is to be used in any of the following conditions.

1. Conditions and environments outside of the given specifications, or use outdoors or in a place exposed to direct sunlight.

2. Installation on equipment in conjunction with atomic energy, railways, air navigation, space, shipping, vehicles, military, medical treatment, combustion and recreation, or equipment in contact with food and beverages, emergency stop circuits, clutch and brake circuits in press applications, safety equipment or other applications unsuitable for the standard specifications described in the product catalog.

3. An application which could have negative effects on people, property, or animals requiring special safety analysis.

4. Use in an interlock circuit, which requires the provision of double interlock for possible failure by using a mechanical protective function, and periodical checks to confirm proper operation.



Speed controller with compact indicator AS-FS*A Series Safety Instructions

Caution

The product is provided for use in manufacturing industries.

The product herein described is basically provided for peaceful use in manufacturing industries. If considering using the product in other industries, consult SMC beforehand and exchange specifications or a contract if necessary.

If anything is unclear, contact your nearest sales branch.

Limited warranty and Disclaimer/Compliance Requirements

The product used is subject to the following “Limited warranty and Disclaimer” and “Compliance Requirements”.

Read and accept them before using the product.

Limited warranty and Disclaimer

- 1.The warranty period of the product is 1 year in service or 1.5 years after the product is delivered,whichever is first.
Also, the product may have specified durability, running distance or replacement parts. Please consult your nearest sales branch.**
- 2. For any failure or damage reported within the warranty period which is clearly our responsibility, a replacement product or necessary parts will be provided.
This limited warranty applies only to our product independently, and not to any other damage incurred due to the failure of the product.**
- 3. Prior to using SMC products, please read and understand the warranty terms and disclaimers noted in the specified catalog for the particular products.**

Compliance Requirements

- 1.The use of SMC products with production equipment for the manufacture of weapons of mass destruction(WMD) or any other weapon is strictly prohibited.**
- 2.The exports of SMC products or technology from one country to another are governed by the relevant security laws and regulation of the countries involved in the transaction. Prior to the shipment of a SMC product to another country, assure that all local rules governing that export are known and followed.**

Caution

SMC products are not intended for use as instruments for legal metrology.

Measurement instruments that SMC manufactures or sells have not been qualified by type approval tests relevant to the metrology (measurement) laws of each country.

Therefore, SMC products cannot be used for business or certification ordained by the metrology (measurement) laws of each country.

2. Specific Product Precautions

Parts and Names of Products

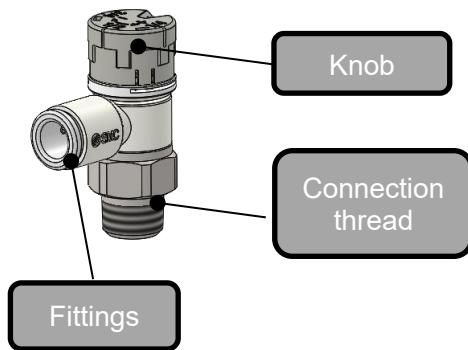

Design/ Selection

Warning

(1) Confirm the specifications.

This product is designed to be used only in a compressed air system (including vacuum). Do not operate at pressures, temperatures, etc., beyond the range of specifications, as this can cause damage or malfunction. (Refer to the specifications.)

Please contact SMC when using a fluid other than compressed air. We do not guarantee against any damage if the product is used outside of the specifications range.

(2) Products mentioned in this catalog are not designed for use as stop valves with zero air leakage.

A certain amount of leakage is allowed in the products specifications. Tightening the needle forcibly to achieve zero leakage may result in damage of stopper.

(3) Speed controllers are designed to control the speed of the actuator.

When using the product for adjustment of blow flow rates or other flow rates, use a restrictor (x214, x21) without the check valve function.

Design/ Selection

Caution

(1) The flow rate characteristics for each product are representative values.

The flow-rate characteristics are those of each individual product. Actual values may differ depending on the piping, circuitry, pressure conditions, etc.

(2) Sonic conductance and critical pressure ratio values for products are representative values.

For controlled flow direction values the needle is fully open. For free flow direction values the needle fully closed.

(3) Check if PTFE can be used in application.

PTFE powder (Polytetrafluoroethylene resin) is included in the seal material of the male thread type piping taper thread. Confirm that the use of it will not cause any adverse effect on the system. Please contact SMC if the Safety Data Sheet (SDS) is required.

Mounting

Caution

(1) Tighten threads with the proper tightening torque. When installing the products, follow the listed proper torque.

(2) Do not use tools such as pliers to rotate the knob.

It can cause idle rotation of the knob or damage.

(3) Verify the air flow direction.

Mounting backward is dangerous, because the speed adjustment needle will not work and the actuator may lurch suddenly.

(4) To adjust the speed, start with the knob in the fully-closed position, and then make adjustments by gradually turning it counterclockwise.

Depending on the opening adjustment condition of the knob (needle), the actuator may jump out. Adjustment of the knob (needle) in the clockwise direction decreases the flow rate (closes), and adjustment in the counterclockwise direction increases the flow rate (opens).

The actuator speed decreases when adjustment in the clockwise direction is made and increases when an adjustment in the counterclockwise direction is made.

Mounting

⚠ Warning

- (5) **Do not apply excessive force or shock to the body or fittings with an impact tool.**
It can cause damage or air leakage.
- (6) **For handling One-touch fittings, refer to the Fittings and Tubing Precautions.**
- (7) **Do not use this product in the operating condition where moment loads will be constantly applied to Body A.**
Body A and the fitting section may be damaged.
- (8) **To install/remove the product, use an appropriate wrench to tighten/loosen at the supplied nut on Body B.**
Do not apply torque at other points as the product may be damaged. Rotate Body A manually for positioning after installation.
- (9) **This product has a stopper for fully close in rotating direction. Excess torque may break the stopper.** Table below shows the maximum allowable torque of the knob.

Connection thread size	Max allowable torque [N · m]
M5	0.05
1/8	0.07
1/4	0.16
3/8	0.2
1/2	0.4

- (10) **When performing the piping work,** turn the tightening tool in the horizontal direction to the hexagon across flats of the body B so that any moment is not applied to the body. If the tool is in contact with the body A, this may cause the body A to come off.

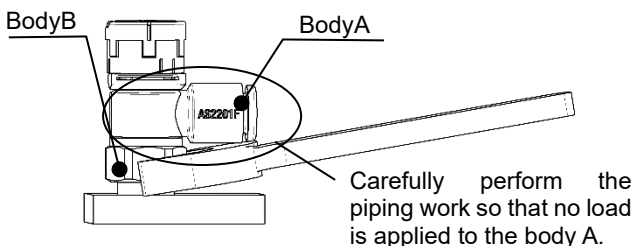

Mounting

⚠ Caution

- (1) **Keep the instruction manual and check its contents.**
Install the products and operate it only after reading the operation Manual carefully and understanding its contents. Also, keep the Manual where it can be referred to as necessary.
- (2) **After pushing the knob down to lock, confirm that it is locked**
Confirm that the knob is locked by pushing the knob in after adjusting the cylinder speed. When the speed controller is unlocked, the set flow may change. If the knob is pulled with force while the speed controller is unlocked, it may result in breakage. When it is unlocked, do not pull the knob out with force.

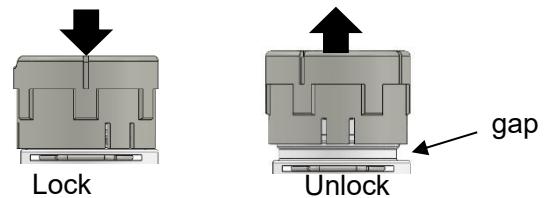

- (3) **Turn the knob slowly in the open or closed direction during operation.**
(Guide for rotation speed: 1 [rev/sec] or below)

Connection thread size	Guide for rotation speed [rev/sec]
M5	1 or below
1/8	1 or below
1/4	0.9 or below
3/8	0.7 or below
1/2	0.7 or below

Scale malfunction may occur if quick adjustment is made between two graduations (for example, 0 →1→0).

Mounting

⚠ Caution

(4) Do not force the knob to turn outside the specified range indicated to the scale.

The scale may indicate a wrong value, possibly leading to a wrong setting.

[Example of wrong use]: While the scale indication range is 0 to 8, turning the scale in the open direction from graduation 8 caused the scale to indicate 0.

Connection thread size	Scale indication range
M5	0~8
1/8	0~10
1/4	0~10
3/8	0~10
1/2	0~10

The scale indication range is also printed on the product.

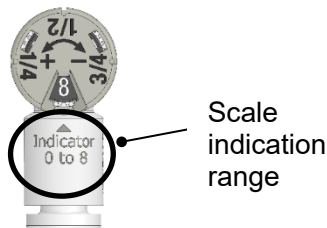

(5) Tubing outside diameter (O.D.) of $\phi 2$

Tube other than that from SMC cannot be used. It may not be possible to connect the tubing to the speed controller, and there may be issues such as air leakage, or the possibility of pulling out the tube after connection.

(6) Installation of Connection thread

(6)-1 For M5,10-32UNF

① Tightening method

First, tighten it by hand, then give it an additional 1/6 turn to 1/4 turn with an appropriate wrench.. Refer to Table below for reference.

Connection thread size	Proper tightening torque [N · m]
M5,10-32UNF	1~1.5

Note) Excessive tightening may damage the thread portion or deform the gasket and cause air leakage. If the screw is too shallowly screwed in, it may come loose or air may leak.

Mounting

⚠ Caution

② Chamfered area for female thread

In compliance with ISO 16030 (air pressure fluid dynamics – connection – ports and stud ends), the chamfered dimensions shown in the table below are recommended.

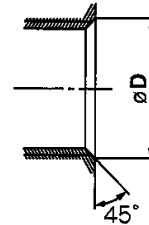

Connection thread size	Chamfer dimension ϕD (Recommended value)
M5	5.1~5.4
10-32UNF	5.0~5.3

(6)-2 For R, NPT, G thread

① Tightening method

When installing the connection thread, tighten it to the appropriate tightening torque as shown in the table below. As a rough guide, 2 turn to 3 turn revolutions with a tool after hand-tightening is equivalent. Please refer to the dimension table of each product for tooling.

Connection thread size (R,NPT,G)	Proper tightening torque [N · m]
1/8	3~5
1/4	8~12
3/8	15~20
1/2	20~25

Mounting

Caution

② Chamfered area of female thread

By chamfering as shown in the table below, machining of threads is easier and effective for burr prevention.

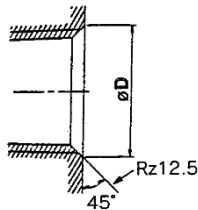

Connection thread size	Chamfer dimension ϕD (Recommended value)		
	Rc	NPT, NPTF	G
1/8	10.2~10.4	10.5~10.7	9.8~10.2
1/4	13.6~13.8	14.1~14.3	13.3~13.7
3/8	17.1~17.3	17.4~17.6	16.8~17.2
1/2	21.4~21.6	21.7~21.9	21.0~21.4

※1 G thread (face seal) complies with ISO16030-2001.

※2 Use G external threads with G internal threads.

(8) Actuator speed check

Large variations in actuator speed can occur as a result of individual product differences due to tolerance of the components, individual actuator differences, operating conditions, temperature, etc. The final actuator speed should be checked each time the setting has been changed.

(9) Lifting force for the knob

The lifting force for the knob is specified as shown in the table below.

Lifting the knob with a lifting force larger than that specified in the table below will cause the knob to come off, make the actuator setting speed or scale incorrect, or cause damage to the product.

Connection thread size	Lifting force N
M5	1~1.5
1/8, 1/4, 3/8, 1/2	3~4

Piping Threads with Sealant

Caution

- (1) If the fitting is tightened with excessive torque, a large amount of sealant will seep out. Remove the excess sealant.
- (2) Insufficient tightening may loosen the threads, or cause air leakage.
- (3) Reuse
 - ① Normally, fittings with a sealant can be reused 2 to 3 times.
 - ② To prevent air leakage through the sealant, remove any loose sealant stuck to the fitting by blowing air over the threaded portion.
 - ③ If the sealant no longer provides effective sealing, wrap sealing tape over the sealant before reusing. Do not use the sealant in any form other than a tape type.
- (4) Once the fitting has been tightened, backing it out to its original position often causes the sealant to become defective. Air leakage will occur
- (5) Use R external threads with Rc internal threads and NPT external threads with NPT internal threads.

piping

Caution

- (1) Refer to the Fittings & Tubing Precautions for handling One-touch fittings.
- (2) Preparation before piping

Before piping is connected, it should be thoroughly blown out with air (flushing) or washed to remove chips, cutting oil and other debris from inside the pipe.
- (3) Winding of sealant tape

When screwing together pipes and fittings, etc., be certain that chips from the pipe threads and sealing material do not get inside the pipe. Also, when the sealant tape is used, leave approx. 1 thread ridges exposed at the end of the threads.

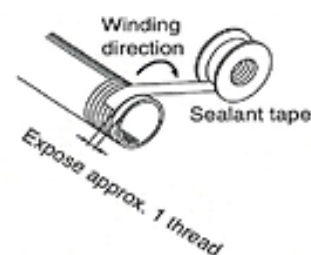

Precautions for One-Touch Tube Fittings
--

Mounting/Piping

 **Caution**
(1) Connection and disconnection of tube from one-touch fitting**① Installation of tube**

- 1) Cut the tube perpendicularly, being careful not to damage the external surface. Use an SMC tube cutter TK Sereis. Do not cut the tubing with pliers, nippers, scissors, etc., otherwise the tubing will be deformed and problems may result.
- 2) The outside diameter of the polyurethane tubing swells when internal pressure is applied to it. Therefore, it may be impossible to re-insert the tubing into One-touch fittings. Check the tubing outside diameter, and when the accuracy of the outside diameter is +0.07mm or larger for $\phi 2$, and +0.15mm or larger for other sizes, re-insert it into the One-touch fitting without cutting the tube. When the tubing is re-inserted into the One-touch fitting, confirm that the tubing goes through the release button smoothly.
- 3) Grasp the tubing, and slowly push it straight (0 to 5°) into the One-touch fitting until it comes to a stop.
- 4) Pull the tubing back gently to make sure it has a positive seal. Insufficient installation may cause air to leak or the tubing to release. As a guide for checking if the tubing is pulled out or not, refer to the following table.

② Removal of the tube

- 1) Push the release button flange evenly and sufficiently to release the tube. Do not push in the tubing before pressing the release button.
- 2) Pull out the tubing while keeping the release button depressed. If the release button is not held down sufficiently, the tubing cannot be withdrawn.
- 3) To reuse the tubing, remove the previously lodged portion of the tubing. If the lodged portion is left on without being removed, it may result in air leakage and make the removal of the tubing difficult.

Precautions for One-Touch Tube Fittings
--

Mounting/Piping

 **Caution**
(2) Connection of the metal rod accessories

Do not use tube, resin plug, reducer, etc. after connecting a fitting with a metal rod (KC series, etc.) to a One-touch fitting. This can cause the disconnection of tube.

(3) When mounting the tube, resin plug or metal rod, do not press the release button.

Do not press the release button unnecessarily before mounting tubing, resin plugs and metal rods. This can cause the disconnection of tube.

(4) When using a tube other than that from SMC, make sure that the tube material and the O.D. accuracy satisfy the following specifications.

- 1) Nylon tube: within ± 0.1 mm
- 2) Soft nylon tube: within ± 0.1 mm
- 3) Polyurethane tube: within -0.2mm to +0.15mm

Do not use a tube that does not satisfy the specified tubing O.D. accuracy, or if a tube has a different I.D., material, hardness, or surface roughness from those of SMC's tube. Please consult with SMC if there is anything unclear. It may cause difficulty in connecting the tube, leakage, disconnection of the tube, or fitting damage.

The quality of $\phi 2$ tubing is not guaranteed if other brand tubing is used due to the quality of the product

Recommended Piping Conditions

- (1) When connecting piping to the One-touch fitting, use a pipe length with sufficient margin, in accordance with the piping conditions shown in Figure 1.

Also, when using a tying band, etc., to bind the piping together, make sure that external force does not come to bear on the fitting. (see Figure 2)

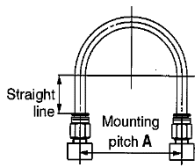

Figure 1 Recommended piping

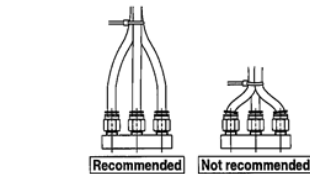

Fig. 2 When using a tying band to bind the piping together

Tubing size	Mounting pitch A			Straight-line Pipe length
	Nylon tube	Soft nylon tube	Polyurethane tube	
φ2	-	-	13or more	10or more
φ3.2, φ1/8"	44or more	35or more	25or more	16or more
φ4, φ5/32"	56or more	44or more	26or more	20or more
φ6	84or more	66or more	39or more	30or more
φ1/4"	89or more	70or more	57or more	32or more
φ8, φ5/16"	112or more	88or more	52or more	40or more
φ10	140or more	110or more	69or more	50or more
φ3/8"	134or more	105or more	69or more	48or more
φ12	168or more	132or more	88or more	60or more
φ1/2"	178or more	140or more	93or more	64or more
φ16	224or more	176or more	114or more	80or more

Unit:mm

Air Supply

Warning

(1) Type of fluids

Please consult with SMC when using the product in applications other than compressed air.

(2) When there is a large amount of drainage

Compressed air containing a large amount of drainage can cause the malfunction of pneumatic equipment. An air dryer or water separator should be installed upstream from filters.

(3) Drain flushing

If condensation in the drain bowl is not emptied on a regular basis, the bowl will overflow and allow the condensation to enter the compressed air lines. This causes the malfunction of pneumatic equipment.

If the drain bowl is difficult to check and remove, the installation of a drain bowl with an auto drain option is recommended.

For compressed air quality, refer to SMC catalog "Compressed Air Purification System".

Air Supply

Warning

(4) Use clean air

Do not use compressed air that contains chemicals, synthetic oils that include organic solvents, salt, corrosive gases, etc., as it can cause damage or malfunction.

Caution

(1) Install an air filter.

Install an air filter at the upstream side of valve. Select a filtration rating of 5 μm or below, or that equivalent to or lower than ISO 8573-1:2010 [6:4:4]

* This rating is equivalent to the rating produced when an air filter is installed for the purity class [7:4:4] of the inlet side compressed air.

(2) Ensure that the fluid and ambient temperatures are within the specified range.

If the fluid temperature is 5°C or less, the moisture in the circuit could freeze, causing damage to the seals or leading to equipment malfunction. Therefore, take appropriate measures to prevent freezing.

For compressed air quality, refer to SMC catalog "Compressed Air Purification System".

Operating environment

Warning

- (1) Do not use in an atmosphere containing corrosive gases, chemicals, sea water, water, water steam, or where there is direct contact with any of these.

- (2) Do not expose the product to direct sunlight for an extended period of time.

- (3) Do not mount the product in locations where it is exposed to radiant heat.

Maintenance

Warnnig

(1) Do not disassemble the product or make any modifications.

Do not disassemble the product or make any modifications, including additional machining. Doing so may cause human injury and/or an accident

(2) Ensure sufficient space for maintenance activities. When installing the products, allow access for maintenance

(3) Perform maintenance and inspection according to the procedures indicated in the operation manual.

If handled improperly, malfunction or damage of machinery and equipment may occur.

(4) Maintenance work

If handled improperly, compressed air can be dangerous.

Assembly, handling, repair and element replacement of pneumatic systems should be performed by a knowledgeable and experienced person.

(5) Drain flushing

Remove drainage from air filters regularly.

(6) Removal of equipment, and supply/exhaust of compressed air.

Before components are removed, first confirm that measures are in place to prevent workpieces from dropping, run-away equipment, etc. Then, Cut the supply pressure and electric power, and exhaust all compressed air from the system using the residual pressure release function. When machinery is restarted, proceed with caution after confirming that appropriate measures are in place to prevent sudden movement.

3.Application

This product is designed to control the speed of a pneumatic actuator.

4.Specifications

Model	AS-FS*A
Fluid	Air
Proof pressure	1.5MPa
Maximum operating pressure	1MPa
Minimum operating pressure	0.1MPa
Ambient and fluid temperature	-5~60°C (No freezing)
Applicable tube materials ^(note 1)	Nylon, soft nylon, polyurethane, FEP, PFA

Note1: Pay attention to the maximum operating pressure for soft nylon and polyurethane.

5.Troubleshooting

Trouble	Possible causes	Countermeasure
Speed(flow) cannot be adjusted.	The speed adjustment direction is incorrect.	Check whether the control is meter-out or meter-in, and then check whether the product is installed at an appropriate position for the actuator.
	Dust inside.	Fully open the needle(or knob) and apply air blow from the free flow side. If the problem is not solved even after air blow, install an air filter to the piping, and replace the product with a new one.
Air leaks from the One-touch fitting. Or the tubing disconnects.	Tubing has been cut using pliers or nipper.	Use tube cutters.
	The tolerance of the outside diameter of the tubing is outside of the specification.	If tubings made by manufacturers other than SMC are used, check the accuracy of the tubing's outside diameter. Nylon tube: Within +/-0.1 mm Soft nylon tube: Within +/-0.1 mm Polyurethane tube: Within -0.2 to +0.15 mm

6.Construction

Seal method/Gasket seal
For M5,10-32UNF

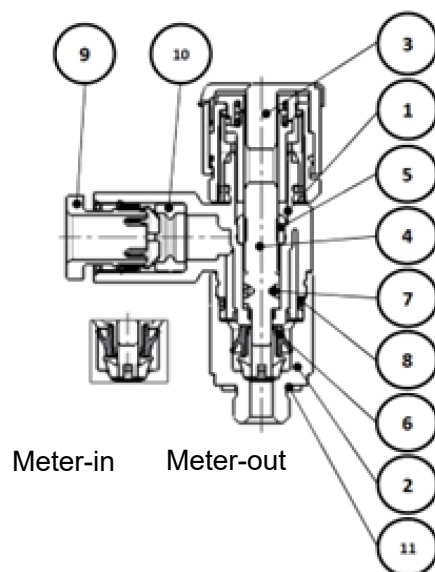

Component Parts

No.	Description	Material	Note
1	Body A	PBT	
2	Body B	Brass ^{Note1)}	Electroless nickel Plated ^{Note1)}
3	Indicator	-	
4	Needle	PBT	
5	Needle guide	Brass ^{Note1)}	Electroless nickel Plated ^{Note1)}
6	U-seal	HNBR	
7	O-ring	NBR	
8	O-ring	NBR	
9	Cassette	-	
10	Seal	NBR	
11	Gasket	NBR/Stainless-steel	

Note1) The stainless-steel version is made without any surface treatment.

Seal method/Sealant
For R,NPT

Seal method/Face seal
For G

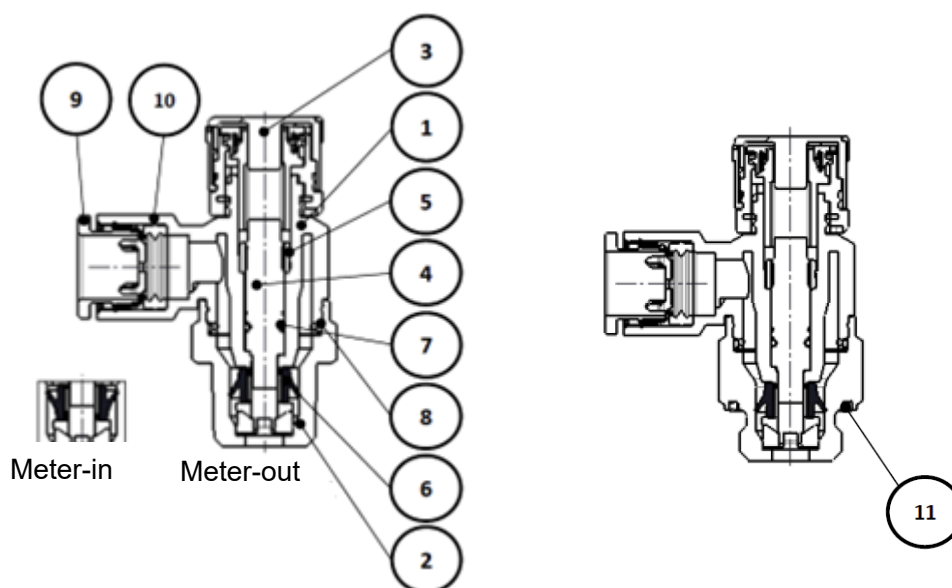

Component Parts

No.	Description	Material	Note
1	Body A	PBT	
2	Body B	Brass ^{Note1)}	Electroless nickel Plated ^{Note1)}
3	Indicator	-	
4	Needle	PBT	
5	Needle guide	Brass ^{Note1)}	Electroless nickel Plated ^{Note1)}
6	U-seal	HNBR	
7	O-ring	NBR	
8	O-ring	NBR	
9	Cassette	-	
10	Seal	NBR	
11	Seal	NBR	

Note1) The stainless-steel version is made without any surface treatment.

Seal method/Gasket seal
For M5,10-32UNF

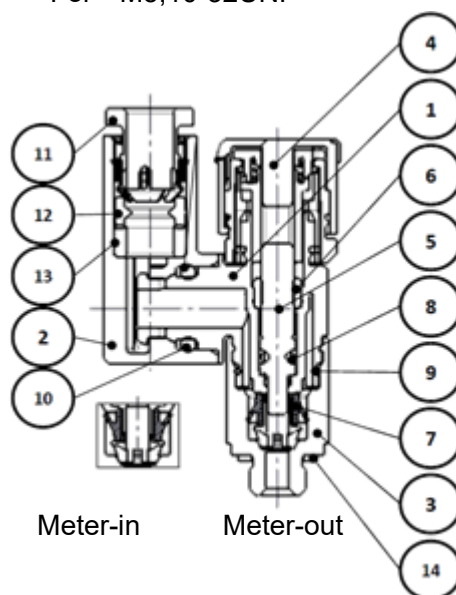

Component Parts

No.	Description	Material	Note
1	Body A	PBT	
2	Elbow body	PBT	
3	Body B	Brass ^{Note2)}	Electroless nickel Plated ^{Note2)}
4	Indicator	-	
5	Needle	PBT	
6	Needle guide	Brass ^{Note2)}	Electroless nickel Plated ^{Note2)}
7	U-seal	HNBR	
8	O-ring	NBR	
9	O-ring	NBR	
10	O-ring	NBR	
11	Cassette	-	
12	Seal	NBR	
13	Spacer	PBT ^{Note1)}	
14	Gasket	NBR/Stainless steel	

Note1) Only the product for tubing sized $\varnothing 3.2$, $\varnothing 1/8$ ", $\varnothing 4$, $\varnothing 5/32$ ", and $\varnothing 6$ contain spacers.

Note2) The stainless-steel version is made without any surface treatment.

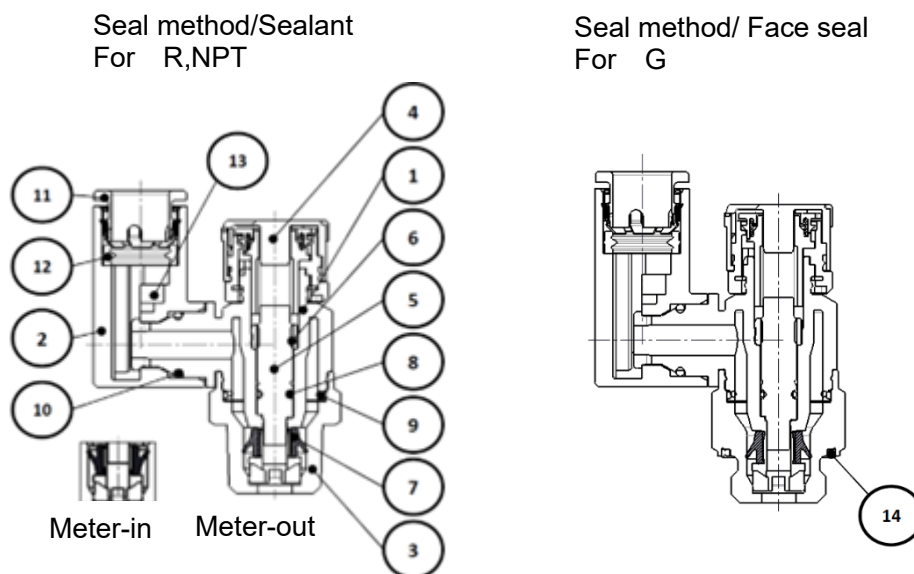

Component Parts

No.	Description	Material	Note
1	Body A	PBT	
2	Elbow body	PBT	
3	Body B	Brass ^{Note2)}	Electroless nickel Plated ^{Note2)}
4	Indicator	-	
5	Needle	PBT	
6	Needle guide	Brass ^{Note2)}	Electroless nickel Plated ^{Note2)}
7	U-seal	HNBR	
8	O-ring	NBR	
9	O-ring	NBR	
10	O-ring	NBR	
11	Cassette	-	
12	Seal	NBR	
13	Spacer	PBT ^{Note1)}	
14	Seal	NBR	

Note1) Only the product for tubing sized Ø3.2, Ø1/8", Ø4, Ø5/32", and Ø6 contain spacers.

Note2) The stainless-steel version is made without any surface treatment.

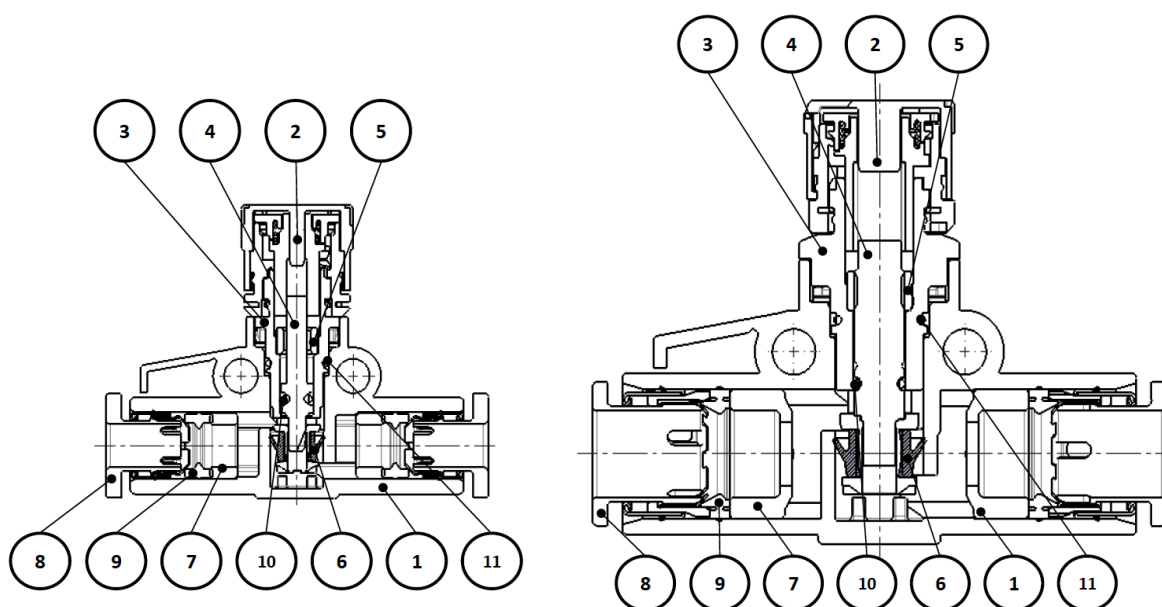

Component Parts

No.	Description	Material	Note
1	Body A	PBT	
2	Indicator	-	
3	Body B	PBT	
4	Needle	PBT	
5	Needle guide	Brass ^{Note2)}	Electroless nickel Plated ^{Note2)}
6	U-seal	HNBR	
7	Spacer	PBT ^{Note1)}	
8	Cassette	-	
9	Seal	NBR	
10	O-ring	NBR	
11	O-ring	NBR	

Note1) AS3002F-11A, AS4002F-11A and AS4002F-13A have electroless nickel plating on the brass parts.

Note2) The stainless-steel version is made without any surface treatment.

Revision history

A version: P6-P8, P14, P16

Size 1/4, 3/8 and 1/2 are added to the table.

Size M3 was deleted from the table.

Correction of errors

SMC Corporation

4-14-1, Sotokanda, Chiyoda-ku, Tokyo 101-0021 JAPAN

Tel: + 81 3 5207 8249 Fax: +81 3 5298 5362

URL <https://www.smcworld.com>

Note: Specifications are subject to change without prior notice and any obligation on the part of the manufacturer.

© 2022 SMC Corporation All Rights Reserved