



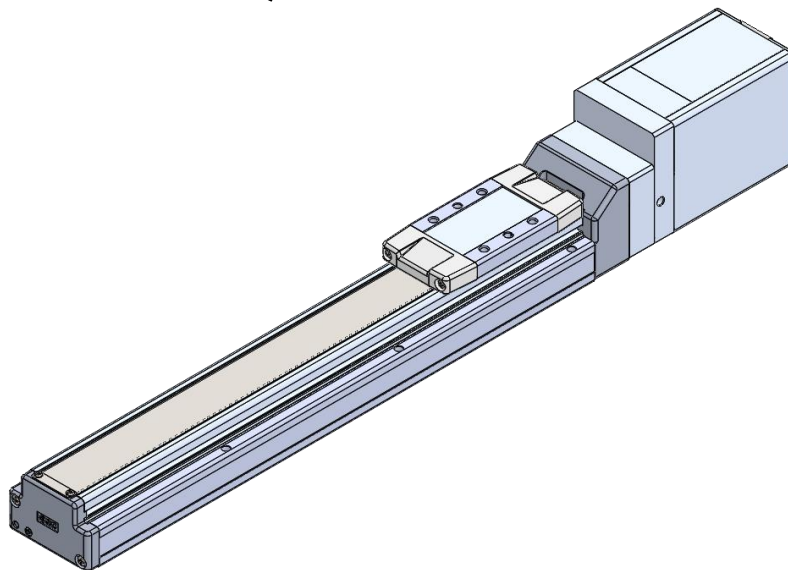
# Operation Manual

PRODUCT NAME

## ***e-Actuator / Slider type*** ***Electric Actuator*** ***Easy to Operate Integrated Controller*** ***(servo 24VDC)***

Model / Series / Product Number

### **EQFS series**



Also check the e-Actuator setup software(e-Actuator setup tool)instruction manual.  
Please download this software from our website.  
<http://www.smcworld.com/>

## **SMC Corporation**

<b>Safety Instructions</b> .....	<b>3</b>
Precautions for product specific.....	5
<b>1 Outlines of Product</b> .....	<b>23</b>
1.1 System configuration example.....	23
1.2 Features .....	24
1.3 How to Order .....	25
1.4 Specification Table.....	26
1.5 Construction.....	27
1.6 Accessories .....	28
<b>2 Installation and Initial Setting</b> .....	<b>29</b>
2.1 Flow from installation to initial setting.....	29
2.2 Check the contents of the packag.....	30
2.3 Preparation of necessary supplies .....	31
2.4 Installation of electric actuators .....	32
2.5 Wiring and Connection.....	33
2.5.1 Connection to input power supply .....	33
2.5.2 Connection to PC.....	38
2.5.3 Connection to PLCs, etc .....	38
2.6 Power ON alarm (error).....	40
2.7 Setup of the operation parameters .....	40
2.8 Test run.....	41
<b>3 Operation</b> .....	<b>42</b>
3.1 Operation flow .....	42
3.2 Procedure for power set up.....	43
3.2.1 Procedure for power start up .....	43
3.2.2 Power Supply Startup.....	43
3.3 Operation Instructions .....	45
3.3.1 Outline of operation command.....	45
3.3.2 Positioning operation .....	45
3.3.3 Reset.....	48
3.4 Operation Examples.....	49
3.4.1 Positioning operation .....	49
<b>4 Operation Mechanism</b> .....	<b>50</b>
4.1 Positioning operation.....	50
4.2 Return to the origin.....	51
4.3 Response time in receiving an electric actuator input signal	52

4.4	Methods of interrupting operation .....	52	
<b>5</b>	<b>Alarm detection .....</b>	<b>53</b>	
5.1	Parallel signal output for the alarm group .....	53	
5.2	Alarm details .....	53	
<b>6</b>	<b>Troubleshooting.....</b>	<b>57</b>	
<b>7</b>	<b>Specifications.....</b>	<b>62</b>	
7.1	Basic specifications of the product.....	62	
7.2	Parts Description .....	63	
7.3	Power supply connector Specification .....	64	
7.4	I/O connector specification .....	65	
7.4.1	Details of parallel input/output signals.....	65	
7.4.2	Parallel input/output specification .....	67	
7.4.3	Parallel input/output type circuit (NPN and PNP specifications)		67
<b>8</b>	<b>Setting .....</b>	<b>68</b>	
8.1	Operation data.....	68	
8.2	Parameter.....	70	
<b>9</b>	<b>Optional parts (sold separately) .....</b>	<b>72</b>	
9.1	Power supply cable .....	72	
9.2	I/O cable .....	72	
9.3	Setup communication cable .....	73	
9.4	Configuration software.....	73	



# e-Actuator/ Slider Type Safety Instructions

These safety instructions are intended to prevent hazardous situations and/or equipment damage. These instructions indicate the level of potential hazard with the labels of “Caution,” “Warning” or “Danger.”

They are all important notes for safety and must be followed in addition to International Standards (ISO/IEC)\*1), and other safety regulations.

\*1) ISO 4414: Pneumatic fluid power -- General rules relating to systems.

ISO 4413: Hydraulic fluid power -- General rules relating to systems.

IEC 60204-1: Safety of machinery -- Electrical equipment of machines .(Part 1: General requirements)

ISO 10218: Manipulating industrial robots -Safety.

etc.



## Caution

**Caution** indicates a hazard with a low level of risk which, if not avoided, could result in minor or moderate injury.



## Warning

**Warning** indicates a hazard with a medium level of risk which, if not avoided, could result in death or serious injury.



## Danger

**Danger** indicates a hazard with a high level of risk which, if not avoided, will result in death or serious injury.

## Warning

### 1. The compatibility of the product is the responsibility of the person who designs the equipment or decides its specifications.

Since the product specified here is used under various operating conditions, its compatibility with specific equipment must be decided by the person who designs the equipment or decides its specifications based on necessary analysis and test results.

The expected performance and safety assurance of the equipment will be the responsibility of the person who has determined its compatibility with the product.

This person should also continuously review all specifications of the product referring to its latest catalog information, with a view to giving due consideration to any possibility of equipment failure when configuring the equipment.

### 2. Only personnel with appropriate training should operate machinery and equipment.

The product specified here may become unsafe if handled incorrectly.

The assembly, operation and maintenance of machines or equipment including our products must be performed by an operator who is appropriately trained and experienced.

### 3. Do not service or attempt to remove product and machinery/equipment until safety is confirmed.

1. The inspection and maintenance of machinery/equipment should only be performed after measures to prevent falling or runaway of the driven objects have been confirmed.

2. When the product is to be removed, confirm that the safety measures as mentioned above are implemented

and the power from any appropriate source is cut, and read and understand the specific product precautions of all relevant products carefully.

3. Before machinery/equipment is restarted, take measures to prevent unexpected operation and malfunction.

### 4. Contact SMC beforehand and take special consideration of safety measures if the product is to be used in any of the following conditions.

1. Conditions and environments outside of the given specifications, or use outdoors or in a place exposed to direct sunlight.

2. Installation on equipment in conjunction with atomic energy, railways, air navigation, space, shipping, vehicles, military, medical treatment, combustion and recreation, or equipment in contact with food and beverages, emergency stop circuits, clutch and brake circuits in press applications, safety equipment or other applications unsuitable for the standard specifications described in the product catalog.

3. An application which could have negative effects on people, property, or animals requiring special safety analysis.

4. Use in an interlock circuit, which requires the provision of double interlock for possible failure by using a mechanical protective function, and periodical checks to confirm proper operation.



# e-Actuator/ Slider Type Safety Instructions

## **Caution**

**The product is provided for use in manufacturing industries.**

The product herein described is basically provided for peaceful use in manufacturing industries.

If considering using the product in other industries, consult SMC beforehand and exchange specifications or a contract if necessary.

If anything is unclear, contact your nearest sales branch.

## Limited warranty and Disclaimer/Compliance Requirements

The product used is subject to the following “Limited warranty and Disclaimer” and “Compliance Requirements”.

Read and accept them before using the product.

### Limited warranty and Disclaimer

1. The warranty period of the product is 1 year in service or 1.5 years after the product is delivered, whichever is first.\*2)

Also, the product may have specified durability, running distance or replacement parts. Please consult your nearest sales branch.

2. For any failure or damage reported within the warranty period which is clearly our responsibility, a replacement product or necessary parts will be provided.

This limited warranty applies only to our product independently, and not to any other damage incurred due to the failure of the product.

3. Prior to using SMC products, please read and understand the warranty terms and disclaimers noted in the specified catalog for the particular products.

\*2) Vacuum pads are excluded from this 1 year warranty.

A vacuum pad is a consumable part, so it is warranted for a year after it is delivered.

Also, even within the warranty period, the wear of a product due to the use of the vacuum pad or failure due to the deterioration of rubber material are not covered by the limited warranty.

### Compliance Requirements

1. The use of SMC products with production equipment for the manufacture of weapons of mass destruction(WMD) or any other weapon is strictly prohibited.
2. The exports of SMC products or technology from one country to another are governed by the relevant security laws and regulation of the countries involved in the transaction. Prior to the shipment of a SMC product to another country, assure that all local rules governing that export are known and followed.

## **Caution**

**SMC products are not intended for use as instruments for legal metrology.**

Measurement instruments that SMC manufactures or sells have not been qualified by type approval tests relevant to the metrology (measurement) laws of each country.

Therefore, SMC products cannot be used for business or certification ordained by the metrology (measurement) laws of each country.

## Precautions for product specific

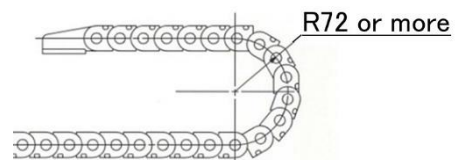
### Precautions for wiring and cable

#### Warning

- ① **Adjustment, installation, inspection, or wiring changes should be conducted after the power supply to this product has been turned off.**  
Electrical shock, malfunction, or damage can result.
- ② **Never disassemble the cable.**
- ③ **Never connect or disconnect the cable or connector with the power on.**

#### Caution

- ① **Wire the connector securely.**  
Do not apply any voltage to the terminals other than those specified in the Operation Manual.
- ② **Wire the connector securely.**  
Check for correct connector wiring and polarity.
- ③ **Take appropriate measures against noise.**  
Noise in a signal line may cause malfunction.  
As a countermeasure, high voltage and low voltage cables should be separated, and keep wiring lengths short, etc.
- ④ **Do not connect power or high-voltage cables in the same wiring path as the unit.**  
The product can malfunction due to noise and surge voltage interference in the signal line from power and high-voltage cables. Separate the wiring of the controller and its peripheral device from that of power and high-voltage cables.
- ⑤ **Take care that actuator movement does not damage cables.**
- ⑥ **Operate with cables secured.**  
Avoid bending cables at sharp angles where they enter the electric actuator.
- ⑦ **Avoid twisting, folding, rotating, or applying external force to the cable.**  
Electric shock, wire breakage, contact failure, or a loss of product control may occur.
- ⑧ **Fix the Communication cable for setting in place before using.**  
Communication cable for setting is not robotic type cable and can be damaged when moved.
- ⑨ **When repeatedly bending power or I/O cables, do not put them in a flexible moving tube with a radius smaller than the specified value (minimum 72mm).**  
If the product is repeatedly bent, please check periodically for cable disconnection and contact failure.



- ⑩ **Confirm wiring insulation.**

Poor insulation (interference with other circuits, poor insulation between terminals and etc.) can apply excessive voltage or current to the product causing damage.

- ⑪ **The speed and force may change depending on the cable length, load, and mounting conditions.**  
Furthermore, if the cable length exceeds 5 m, then it will decrease by up to 10% for every additional 5 m.(If cable length is 15m: Maximum 20% reduction.)
- ⑫ **When checking the conductivity of the cable, be careful not to deform the connector's mating hole and terminals.**  
Inserting a non-compatible connector, tool, cylinder-shaped object, etc., into the connector's mating hole can cause the mating hole or terminals to become deformed, which may cause contact failure or disconnection.
- ⑬ **Refrain from plugging in and unplugging the connector frequently.**  
Doing so may result in contact failure or disconnection.
- ⑭ **Do not connect wires while power is being supplied.**  
It may cause the electric actuator to break or its peripheral devices could be damaged, causing a malfunction.

## 【Transportation】

### ⚠ Caution

- ① **Do not carry or swing the product by the cable and motor.**

## Electric Actuators / Common Precautions

### ■ Design

### ⚠ Warning

- ① **Be sure to read the Operation Manual (this manual ).**  
Handling or usage/operation other than that specified in the Operation Manual may lead to breakage and product failure.  
Any damage attributed to the use beyond the specifications is not guaranteed.
- ② **There is a possibility of dangerous sudden action by the product if sliding parts of machinery are twisted due to external forces etc.**  
In such cases, human injury may occur, such as by catching hands or feet in the machinery, or damage to the machinery itself may occur. Design the machinery should be designed to avoid such dangers.
- ③ **A protective cover is recommended to minimize the risk of personal injury.**  
If a driven object and moving parts of the product are in close proximity, personal injury may occur. Design the system to avoid contact with the human body.
- ④ **Securely tighten all stationary parts and connected parts so that they will not become loose.**  
When the product operates with high frequency or is installed where there is a lot of vibration, ensure that all parts remain secure.
- ⑤ **Consider a possible loss of power source.**  
Take measures to prevent injury and equipment damage even in the case of a power source failure.
- ⑥ **Consider behavior of emergency stop of whole system.**  
Design the system so that human injury and/or damage to machinery and equipment will not be caused, when it is stopped by a safety device for abnormal conditions such as a power outage or a manual emergency stop of whole system.
- ⑦ **Consider the action when operation is restarted after an emergency stop or abnormal stop of whole system.**  
Design the system so that human injury or equipment damage will not occur upon restart of operation of whole system.
- ⑧ **Never disassemble or modify(including additional machining) the product.**  
An injury to failure can result. It will cause the loss of the product performance.



- ⑨ **Do not use the stop signal as the emergency stop of the system.**  
Stop by shutdown of M24V is for stopping the electric actuator with deceleration.  
For the emergency stop of the equipment, design the system with a separate emergency stop circuit conforming to relevant safety standards.
- ⑩ **When using it for vertical application, it is necessary to build in a safety device.**  
The rod may fall due to the weight of work. The safety device should not interfere with normal operation of the machine.
- ⑪ **Do not exceed the product specifications even if a work load is supported by external guides.**  
Although the Electric actuator moment is reduced by external guides, the required trans- port ability (the relationship between the speed and the work load) is not reduced.
- ⑫ **In order to prevent danger and damage due to the breakdown and the malfunction of this product, which may occur at a certain probability, a backup system should be established in advance by giving a multiple-layered structure or a fail-safe design to the equipment, etc.**
- ⑬ **Avoid designing a system that allows the driving part of an electric actuator to operate with a spring or other external force.**

### **Caution**

- ① **Operate within the limits of the maximum usable stroke.**  
The product will be damaged if it is used with a stroke which exceeds the maximum stroke. Refer to the specifications of the product.
- ② **When the product repeatedly cycles with partial strokes, operate it at a full stroke at least once a day or every 1000 strokes.**  
Otherwise, lubrication can be lost.
- ③ **Do not use the product in applications where excessive external force or impact force is applied to it.**  
The product can be damaged. The components, including the motor, are manufactured to precise tolerances. Even a slight deformation may cause a malfunction or seizure.
- ④ **Refer to the Auto Switches Precautions (Best Pneumatics No②) if an auto switch is to be built in and used.**
- ⑤ **When UL Standards compliance is required, the electric actuator and controller/driver should be used with a UL1310 class 2 power supply.**
- ⑥ **Do not exceed the product specifications even if a work load is supported by external guides.**  
Although the actuator moment is reduced by external guides, the required trans- port ability (the relationship between the speed and the work load) is not reduced.

### ■ **Mounting**

#### **Warning**

- ① **Install and operate the product only after reading the Operation Manual carefully and understanding its contents. Keep the manual in a safe place for future reference.**
- ② **Observe the tightening torque for screws.**  
Tighten the screws to the recommended torque for mounting the product.
- ③ **Do not make any alterations to this product.**  
Alterations made to this product may lead to a loss of durability and damage to the product, which can lead to human injury and damage to other equipment and machinery.
- ④ **When an external guide is used, connect the moving parts of the product and the load in such a way that there is no interference at any point within the stroke.**  
Do not scratch or damage the sliding part by hitting it with an object. Components are manufactured to precise tolerances, so the slightest deformation may cause faulty operation.



- ⑤ **Prevent the seizure of rotating parts (pins, etc.) by applying grease.**
- ⑥ **Do not use the product until you verify that the equipment can operate properly.**  
After mounting or repair, connect the power supply to the product and perform appropriate functional inspections to check it is mounted properly.
- ⑦ **When one side is fixed**  
When an actuator is operated at a high speed with one end fixed and the other free (basic, flange, or direct mount types), a bending moment may act on the actuator due to the vibration generated at the stroke end, which can damage the actuator. In such a case, install a mounting bracket to suppress the vibration of the actuator body, or reduce the speed so that the actuator does not vibrate. Also, use a mounting bracket when moving the actuator body or when a long stroke actuator is mounted horizontally and fixed at one end.
- ⑧ **When mounting the actuator or attaching to the work piece, do not apply strong impact or large moment.**  
If an external force over the allowable moment is applied, it may cause looseness in the guide unit, an increase in sliding resistance or other problems.
- ⑨ **Maintenance space**  
Allow sufficient space for maintenance and inspection.
- ⑩ **The electric actuator and its peripheral devices should be installed on a fire-proof material.**  
Direct installation on or near a flammable material may cause a fire.
- ⑪ **Do not install the product in a place subject to vibrations and impacts.**  
It will cause failure or malfunction.
- ⑫ **Take measures to ensure that the operating temperatures of the electric actuator and its peripheral devices are within the range of the specifications.**  
**also should be installed with 50mm or larger spaces between each side of it and the other structures or components.**  
It may cause a malfunction of the controller and its peripheral devices and a fire.
- ⑬ **Do not mount the controller and its peripheral devices near a large electromagnetic contactor or no-fuse breaker which generates vibration on the same panel. Mount them on different panels, or keep the controller and its peripheral devices away from such a vibration source.**
- ⑭ **Install the electric actuator and its peripheral devices on a flat surface.**  
If the mounting surface is distorted or uneven, an unacceptable force may be added to the housing, etc., causing problems.

## ■ Handling

### Warning

- ① **Do not touch the motor while in operation.**  
The surface temperature of the motor can increase to approx. 80°C due to operating conditions. Energizing alone may also cause this temperature increase. As it may cause burns, do not touch the motor when in operation.
- ② **If abnormal heating, smoking or fire, etc., occurs in the product, immediately shut off the power supply.**
- ③ **Immediately stop operation if abnormal operation noise or vibration occurs.**  
If abnormal operation noise or vibration occurs, the product may have been mounted incorrectly. Unless operation of the product is stopped for inspection, the product can be seriously damage
- ④ **Never touch the rotating part of the motor or moving part of the actuator while operation.**

- ⑤ **When installing, adjusting, inspecting or performing maintenance on the product, controller and related equipment, be sure to shut off the power supply to them. Then, lock it so that no one other than the person working can turn the power on, or implement measures such as a safety plug.**
- ⑥ **The inside of the electric actuator and its connector should not be touched.**  
It may cause an electric shock or damage to the controller.
- ⑦ **Do not perform the operation or setting of the product with wet hands.**  
Doing so may cause an electric shock.
- ⑧ **Products with damage or those missing any components should not be used.**  
An electric shock, fire, or injury may result.
- ⑨ **Be careful not to be caught or hit by the workpiece while the electric actuator is moving.**  
It may cause an injury.
- ⑩ **Do not connect the power supply or power on the product before confirming the area to which the work- piece moves is safe.**  
The movement of the workpiece may cause an accident.
- ⑪ **Before installation, wiring, and maintenance, the voltage should be checked with a tester 5 minutes after the power supply has been turned off.**  
Otherwise, an electric shock, fire, or injury may result.
- ⑫ **Do not use the product in an area where dust, powder dust, water, chemicals, or oil is in the air.**  
It will cause failure or malfunction.
- ⑬ **Do not use the product in an area where a magnetic field is generated.**  
It will cause failure or malfunction.
- ⑭ **Do not install the product in an environment containing flammable gas, explosive gas, or corrosive gas.**  
It could lead to fire, explosion and corrosion.
- ⑮ **Radiant heat from strong heat sources, such as a furnace, direct sunlight, etc., should not be applied to the product.**  
It will cause failure of the electric actuator or its peripheral devices.
- ⑯ **Do not use the product in an environment subject to a temperature cycle.**  
It will cause failure of the electric actuator or its peripheral devices.
- ⑰ **Do not use the product in a place where surges are generated.**  
When there are units that generate a large amount of surge around the product (e.g. solenoid type lifters, high-frequency in- duction furnaces, motors, etc.), this may cause deterioration or damage to the product's internal circuit. Avoid sources of surge generation and crossed lines.
- ⑱ **Do not install the product in an environment under the effect of vibrations and impacts.**  
It will cause failure or malfunction.
- ⑲ **When a surge-generating load, such as a relay or solenoid valve, is driven directly, use a product that incorporates a surge absorption element.**

## **Caution**

- ① **Conduct the following inspection before operation.**
  - a) Confirm that the power supply line and each signal line is not damaged.
  - b) Play and looseness of the connector to each power line and signal line
  - c) Play and looseness of the mounting
  - d) Confirm that the electric actuator/cylinder/controller/driver is operating correctly.
  - e) Confirm the function of the emergency stop of the whole system.
- ② **If several persons are to be working conjointly, determine the procedure, signs, measures against abnormality, and restarting measures in advance. Then, have someone else, supervise the work.**
- ③ **The product may operate at a speed different from the set speed depending on the load and resistance.**

When selecting a product, check the catalog for instructions regarding selection and specifications.
- ④ **Do not apply a load, impact, or resistance in addition to the transferred load during the return to origin.**

If the product is made to return to origin by pushing force, a displacement of the origin position may occur.
- ⑤ **Do not remove the name plate.**
- ⑥ **Operation tests should be done at a low speed. Start operation by predefined speed after confirming there are no problems.**
- ⑦ **Do not apply forces of impact, collision, or resistance to the moving parts of an actuator in operation.**

Doing so will cause a decrease in product life, damage to the product, etc.

## **【Grounding】**

### **Warning**

- ① **Ensure that the product is grounded to allow the noise tolerance of the electric actuator.**

Otherwise it may cause an electric shock or fire.
- ② **Dedicated grounding should be used.**

Grounding should be to a D-class ground. (Ground resistance 100Ω or less)
- ③ **The earth cable length should be as short as possible.**
- ④ **In the unlikely event that malfunction is caused by the ground connection, it may be disconnected.**

## **■ Power supply**

### **Caution**

- ① **Use a power supply that has low noise between lines and between the power and ground.**

In cases where noise is high, an isolation transformer should be used.
- ② **The grounding point should be as near as possible to the electric actuator length short.**

If the power supply is of the “inrush-current limited” type, a voltage drop may occur during the acceleration or deceleration of the actuator.
- ③ **To prevent lightning surges, appropriate measures should be taken. Ground the surge absorber for lightning separately from the grounding of the controller and its peripheral devices.**

## 【Unpackaging】

### Caution

① **Check the received product is as ordered.**

If the different product is installed from the one ordered, injury or damage can result.

### ■ Operating environment

### Warning

① **Avoid use in the following environments.**

1. Locations where a large amount of dust and cutting chips are airborne.
2. Locations where the ambient temperature is outside the range of the temperature specification (refer to specifications).
3. Locations where the ambient humidity is outside the range of the humidity specification (refer to specifications).
4. Locations where corrosive gas, flammable gas, sea water, water and steam are present.
5. Locations where strong magnetic or electric fields are generated.
6. Locations where direct vibration or impact is applied to the product.
7. Areas that are dusty, or are exposed to splashes of water and oil drops.
8. Areas exposed to direct sunlight (ultraviolet rays).
9. Environment at an altitude of 1000 meters or higher.

Heat dissipation and withstand voltage will decrease. Contact SMC for details.

② **Do not use in an environment where the product is directly exposed to liquid, such as cutting oils.**

If cutting oils, coolant or oil mist contaminates the product, failure or increased sliding resistance can result.

③ **Install a protective cover when the product is used in an environment directly exposed to foreign matter such as dust, cutting chips and spatter.**

Play or increased sliding resistance can result.

④ **Shade the sunlight in the place where the product is applied with direct sunshine.**

⑤ **Shield the product if there is a heat source nearby.**

When there is a heat source surrounding the product, the radiated heat from the heat source can increase the temperature of the product beyond the operating temperature range.

⑥ **Grease oil can be reduced due to the external environment and operating conditions. The lubrication performance may deteriorate and shorten the life of the product.**

## 【Storage】

### Warning

① **Do not store the product in a place in direct contact with rain or water drops or is exposed to harmful gas or liquid.**

② **Store in an area that is shaded from direct sunlight and has a temperature and humidity within the specified range (-10°C to 60°C and 35% to 85% no condensation or freezing).**

③ **Do not apply vibration and impact to the product during storage.**

### ■ Maintenance

### Warning

① **Do not disassemble or repair the product.**

Fire or electric shock can result. Contact SMC, in case of disassembly for the maintenance.

② **Before modifying or checking the wiring, the voltage should be checked with a tester 5 minutes after the power supply is turned off.**

Electric shock can result.

- ③ **Install the electric actuator and its peripheral devices on a fire-proof material.**  
Direct installation on or near a flammable material may cause a fire.
- ④ **Do not install the product in a place subject to vibrations and impacts.**  
It will cause failure or malfunction.
- ⑤ **Take measure so that the operating temperature of this controller and its peripheral devices are within the range of the specifications. Also, this controller should be installed with 50mm or larger spaces between each side of it and the other structures or components.**  
It may cause a malfunction of the controller and its peripheral devices and a fire.
- ⑥ **Do not mount the controller and its peripheral devices near a large electromagnetic contactor or no-fuse breaker which generates vibration on the same panel. Mount them on different panels, or keep the controller and its peripheral devices away from such a vibration source.**
- ⑦ **Install the electric actuator and its peripheral devices on a flat surface.**  
If the mounting surface is distorted or uneven, an unacceptable force may be added to the case, etc., causing problems.

 **Caution**

- ① **Maintenance should be performed according to the procedure indicated in the Operation Manual.**  
Incorrect handling can cause an injury, damage or malfunction of equipment and machinery.
- ② **Removal of product**  
When equipment is serviced, first confirm that measures are in place to prevent dropping of work pieces and run-away of equipment, etc., and then cut the power supply to the system. When machinery is restarted, check that operation is normal with actuators in the proper positions.

**【Lubrication】**

 **Caution**

- ① **The product has been lubricated for life at manufacturer, and does not require lubrication in service.**  
Contact SMC if lubrication will be applied.

■ **Precautions for actuator with lock**

 **Warning**

- ① **Do not use the lock as a safety lock or a control that requires a locking force.**  
The lock used for the product with a lock is designed to prevent dropping of work piece.
- ② **For vertical mounting, use the product with a lock.**  
If the product is not equipped with a lock, the product will move and drop the work piece when the power is removed. If the actuator with lock is not used, preventive measure should be taken by the design of equipment.
- ③ **"Measures against drops" means preventing a work piece from dropping due to its weight when the product operation is stopped and the power supply is turned off.**
- ④ **Do not apply an impact load or strong vibration while the lock is activated.**  
If an external impact load or strong vibration is applied to the product, the lock will lose its holding force and damage to the sliding part of the lock or reduced lifetime can result. The same situations will happen when the lock slips due to a force higher than its holding force, as this will accelerate the wear to the lock.
- ⑤ **Do not apply liquid or oil and grease to the lock or its surrounding.**  
When liquid or oil and grease are adhered to the sliding part of the lock, its holding force will reduce significantly. Or, lock sliding part performance and condition changes may be cause of lock release malfunction.

- ⑥ **Take measures against drops and check that safety is assured before mounting, adjustment and inspection of the product.**  
If the lock is released with the product mounted vertically, a work piece can drop due to its weight.
- ⑦ **When the actuator is operated manually, supply 24VDC to the [LK RLS] terminal of the power supply connector.**  
If the product is operated without releasing the lock, wearing of the lock sliding surface will be accelerated, causing reduction in the holding force and the life of the locking mechanism.
- ⑧ **Do not supply 24VDC power supply constantly to the [LK RLS(Lock release)] terminal.**  
Only supply 24 VDC power supply to the [LK RLS(Lock release)] terminal during normal operation.  
If power is supplied to the [LK RLS] terminal continuously, the lock will be released, and workpieces may be dropped at stop

## Electric actuators / Common precautions

### ■ Design/ Selection

#### ⚠ Caution

- ① **Do not apply a load in excess of the actuator specification.**  
A product should be selected based on the maximum work load and allowable moment.  
If the product is used outside of the operating specification, eccentric load applied to the guide will become excessive and have adverse effects such as creating play in the guide, reduced accuracy and reduced product life.
- ② **Do not exceed the speed limit of the specification.**  
Select a suitable actuator by the relationship of allowable work load and speed. Noise or reduction of accuracy may occur, if the actuator is operated in excess of its specification. This could lead to reduced accuracy and reduced product life.
- ③ **Do not use the product in applications where excessive external force or impact force is applied.**  
This can lead to premature failure of the product.
- ④ **When the product repeatedly cycles with partial strokes (see the table below), operate it at a full stroke at least once every 10 strokes.**  
Otherwise, lubrication can be lost.

Model	Partial stroke
EQFS25	65mm or less
EQFS32	70mm or less
EQFS40	105mm or less

- ⑤ **Actuator sizing is necessary with the total workload including the external force if external force is added on the actuator table.**  
When mounting cable-duct to actuator, the resistance of actuator table may increase.  
It Causes an overload alarm, so pay attention to the resistance.

## ■ Handling

### Caution

#### ① OUT output signal

##### 1) Positioning Operation

When the actuator moves to within a set range using parameter 【OUT output signal with】 , the output signal, INP, will be turned on.

Set to [0.50] or higher. It may cause malfunction.

#### ② Do not operate by fixing the table and moving the actuator body.

An excessive load will be applied to the table, which could lead to damage to the actuator and reduced accuracy and reduced product life.

#### ③ Check the specification for the minimum speed of each actuator. Operation outside the specifications may cause malfunctions such as knocking.

#### ④ Actual speed of the product can be changed by load.

When selecting a product, check the catalog for the instructions regarding selection and specifications.

#### ⑤ Do not apply a load, impact or resistance in addition to a transferred load during return to origin.

Otherwise, the origin can be displaced since it is based on the detected motor torque.

#### ⑥ Do not dent, scratch or cause other damage to the body and table mounting surfaces.

Damage can cause reduction in flatness, play in the guide and an increase in sliding resistance.

#### ⑦ Do not hit the table with the workpiece in the positioning operation and positioning range.

#### ⑧ There is a type where grease is applied to the dust seal band for sliding. When wiping off the grease remove foreign matter,etc...,be sure to apply grease again.

#### ⑨ For bottom mounting, the dust seal band may be deflected., be sure to apply grease again.

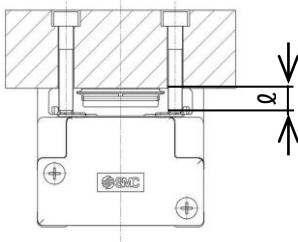


## ■ Mounting

### ⚠ Caution

- ① Design the installation so that the temperature surrounding the actuator is 40°C or less.
- ② Keep the flatness of mounting surface to within [0.1mm or less for length 500mm].  
Insufficient flatness of the work piece or the surface onto which the actuator body is to be mounted can cause play in the guide and increased sliding resistance.
- ③ When mounting the workpiece or other device to the actuator tighten the fixing screws with adequate torque within the specified torque range.  
Tightening the screws with a higher torque than the maximum may cause malfunction, whilst tightening with a lower torque can cause the displacement of the mounting position or in extreme conditions detaching of the work piece.

Work piece fixed

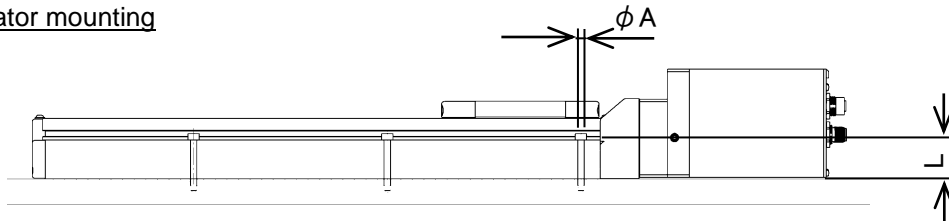


Model	Bolt size	Maximum tightening torque [Nm]	ℓ Max.thread depth (mm)
EQFS25	M5 x 0.8	3.0	8
EQFS32	M6x1	5.2	9
EQFS40	M8 x 1.25	12.5	13

Use screws with adequate length, but with length less than the maximum thread depth.  
The use of screws that are too long can touch the body and cause malfunction.  
(Approximate bolt length: 0.5 mm or more shorter than Max. thread depth)

- ④ When mounting the workpiece or other device to the actuator tighten the fixing screws with adequate torque within the specified torque range.  
Tightening the screws with a higher torque than the maximum may cause malfunction, whilst tightening with a lower torque can cause the displacement of the mounting position or in extreme conditions detaching of the work piece.

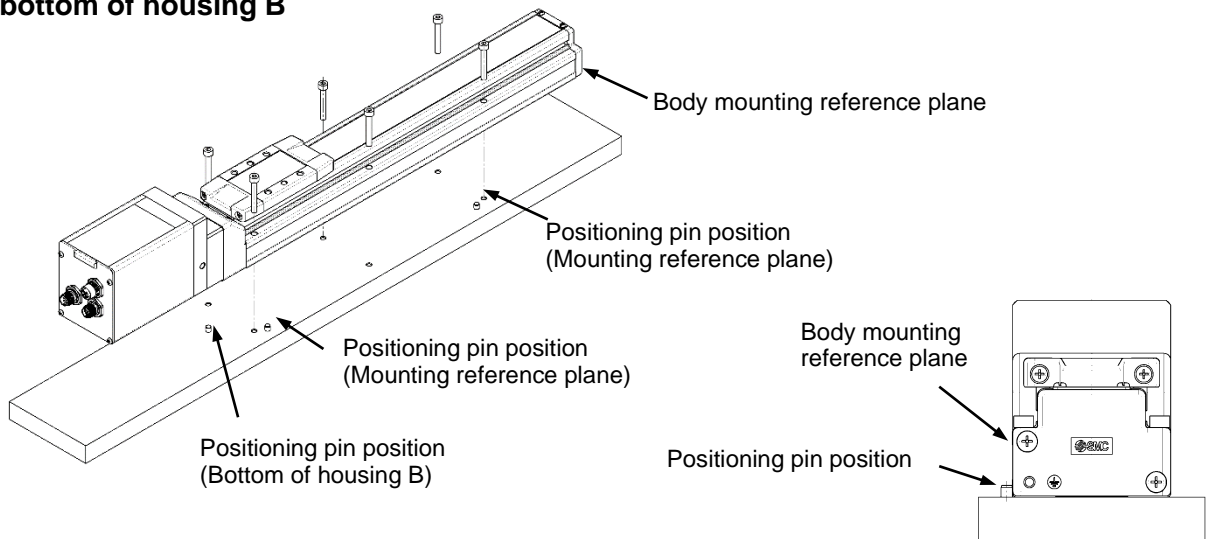
Actuator mounting



Model	Bolt size	φA [mm]	L [mm]
EQFS25	M4	4.5	24
EQFS32	M5	5.5	30
EQFS40	M6	6.6	31

## Body mounting example

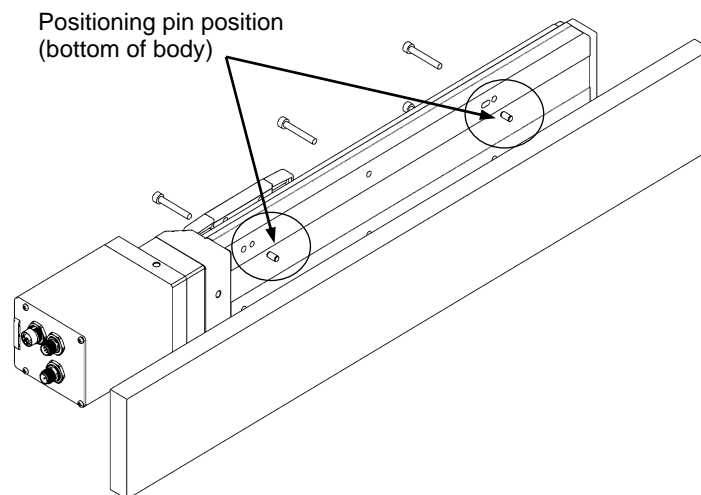
### For bottom of housing B



Body mounting reference plane is the datum level for running parallelism.

If the running parallelism of the table is required, install it by pressing the datum level against parallel pins or the like.

### For the bottom of the body



- ⑤ When mounting the actuator, leave a gap of 40mm or more to allow for bending of the actuator cable.

### **Caution**

If the mounting surface of the controller is distorted or not flat, excessive force may be applied to the housing, etc. causing malfunction.  
Mount this product on a plane surface.

## ■ Maintenance

### ⚠ Caution

- ① Cut the power supply during maintenance and replacement of the product.

#### 【 Maintenance frequency 】

Perform maintenance according to the table below.

Please contact SMC if there are any problems.

Frequency	Appearance check	Internal check	Belt check
Inspect daily before operating	○	-	-
Inspection every six months / 1000km / 5million cycle*	○	○	○

\*Either of inspection early time is selected.

#### 【 Items for visual appearance check 】

1. Loose set screws, abnormal dirt.
2. Check of flaw and cable joint
3. Vibration, noise

#### 【 Items for internal check 】

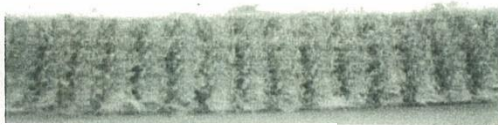
1. Lubricant condition on moving parts.
2. Loose or mechanical play in fixed parts or fixing screws.

#### 【 Items for belt check 】

Stop operation immediately and contact SMC when the belt appears to be like photographs shown below.

##### a. Tooth shape canvas is worn out

Canvas fiber becomes fuzzy. Rubber is removed and the fiber becomes whitish. Lines of fibers become unclear.



Teeth become fuzzy

##### b. Peeling off or wearing of the side of the belt

Belt corner becomes round and frayed thread sticks out.



Bottom portion of belt gear worm-out (frayed thread exposed )

##### c. Belt partially cut

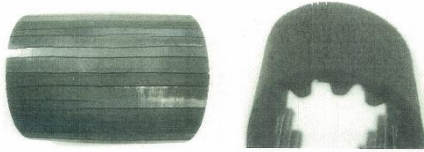
Belt is partially cut. Foreign matter caught in teeth other than cut part causes flaw.

**d. Vertical line of belt teeth**

Flaw which is made when the belt runs on the flange.

**e. Rubber back of the belt is softened and sticky**

**f. Crack on the back of the belt**



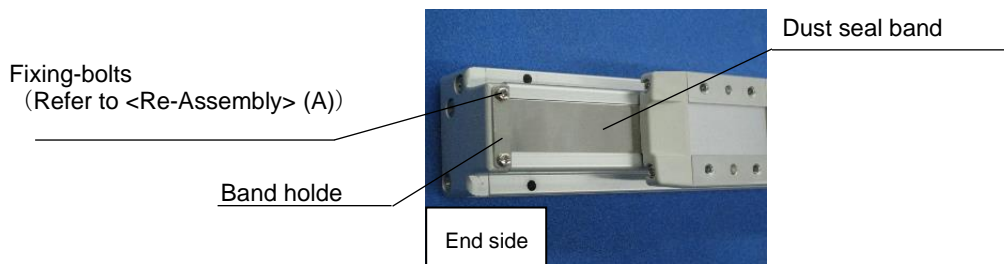
■ **How to detach and attach the dust seal band**

For the internal-check as the maintenance, the method of detaching and attaching the dust seal band is shown as the following.

**[Dis-assembly]**

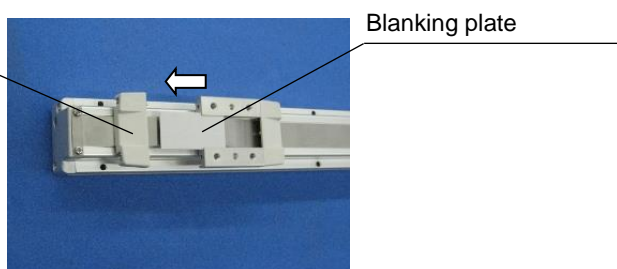
- ① **Loosen the fixing bolts of end side of the “Band holder”.** (The picture shows LEFB, but LEFS is same instruction as LEFB.)

Pay attention to not cut hand on the edges of the “Dust seal band”. The “Dust seal band” can only be removed by loosening the “Band holder” bolts.

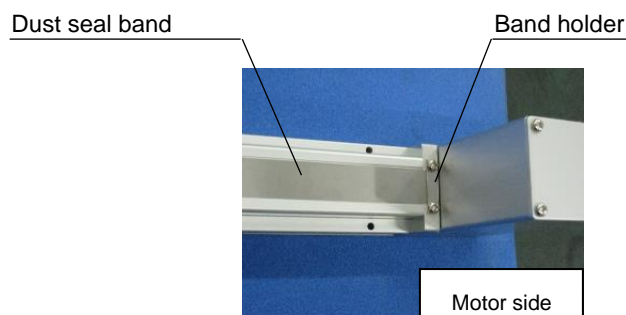


- ② **Remove the “Seal band holder” and the “plate” as shown.**

Seal band holder  
(Refer to <Re-assembly> (B))



- ③ **Loosen the fixing bolts of motor side of the “Band holder” and then remove the “Dust seal band”.**



## 【Mounting】

【Dis-assembly】 The re-assembly is completed by the reverse procedure of “Dis-assembly” sections ①, ② and ③.

(A)

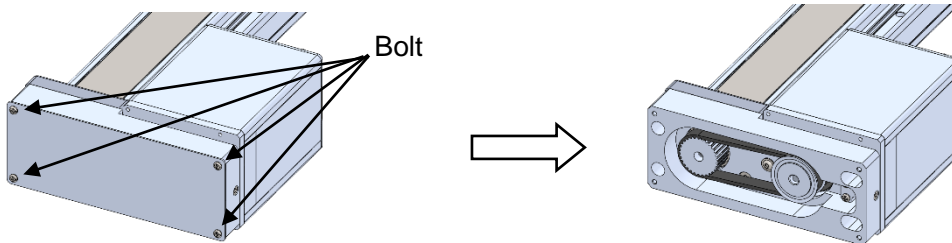
Model	Type of bolt	Bolt size
EQFS25	Round head combination screw	M3x6
EQFS32		
EQFS40		

(B)

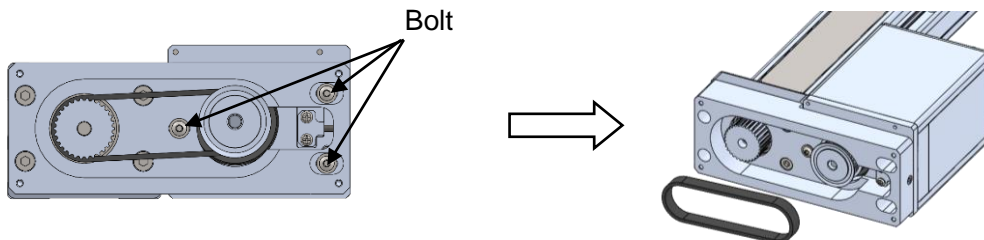
Model	Type of bolt	Bolt size
EQFS25	Cross recessed round head screw	M3x20
EQFS32		M4x30
EQFS40		M4x35

### ■ Replacement of belt

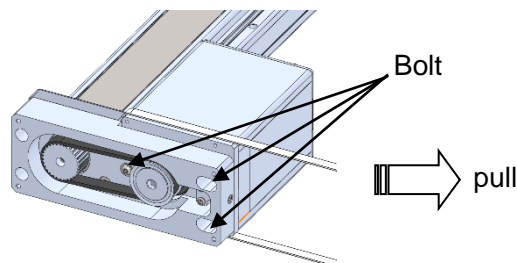
- ① After Bolt is removed, "Pulley plate" is removed.



- ② The bolt that is the fixation of "Motor" is loosened (To extent in which the slide can be done), and "Bearing support" is removed, and "Belt" is removed.



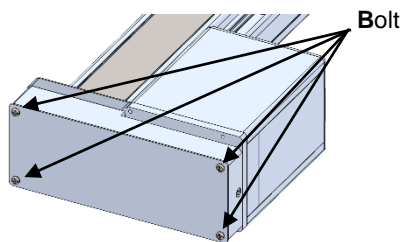
- ③ After "Belt" is installed, and the bearing support is obtained, the root of "Motor" is pulled in a string or a long banding band. With tensile force adjusted, tighten the bolts which fix the actuator to the motor. (Refer to the table below)



Model	Belt Part number	Pull tension [N]
EQFS25	LE-D-15-1	19.6
EQFS32	LE-D-19-1	49.0
EQFS40	LE-D-19-2	70.0

Model	Bolt size	Tightening torque [Nm]
EQFS25	M3	0.63±10%
EQFS32	M4	1.5±10%
EQFS40		

④ "Pulley plate" is installed. (Refer to the table below)



Model	Thread size	Tightening torque [Nm]
EQFS25	M3	0.36±10%
EQFS32		
EQFS40		

## Specific precautions for Battery-less absolute encode

### ⚠ Warning

① **Do not use in an environment where a strong magnetic fields are present.**

A magnetic sensor is used in the encoder.

Therefore, if the actuator motor is used in a strong magnetic field environment, malfunction or failure may occur.

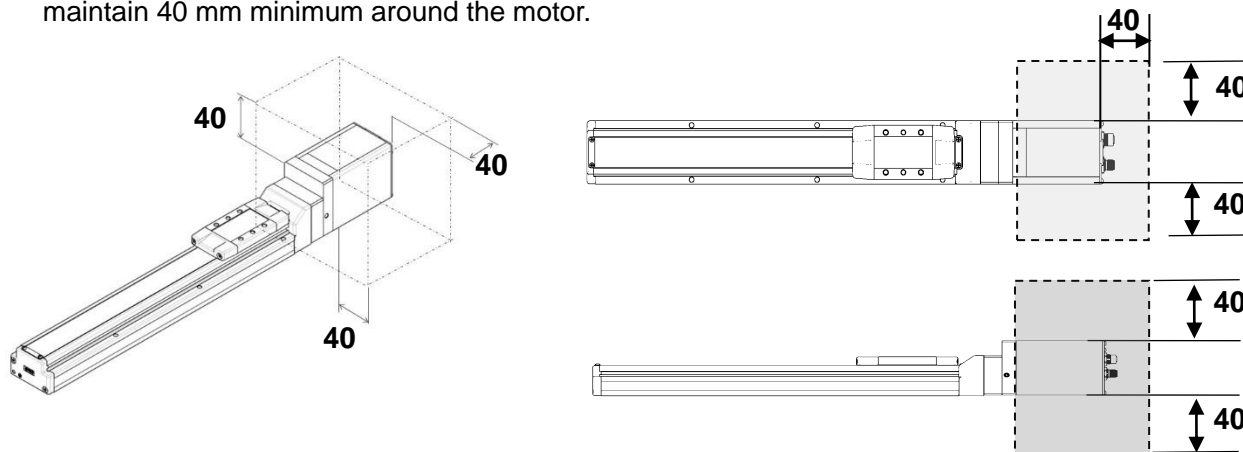
The major failure is described below.

- Reduction of transporting ability (pushing force, speed)
- Damage to the actuator due to collision to the workpiece by positional displacement occurred.

Do not expose the actuator motor to a magnetic field with a magnetic flux density of 13 mT or more.

(Example 1)

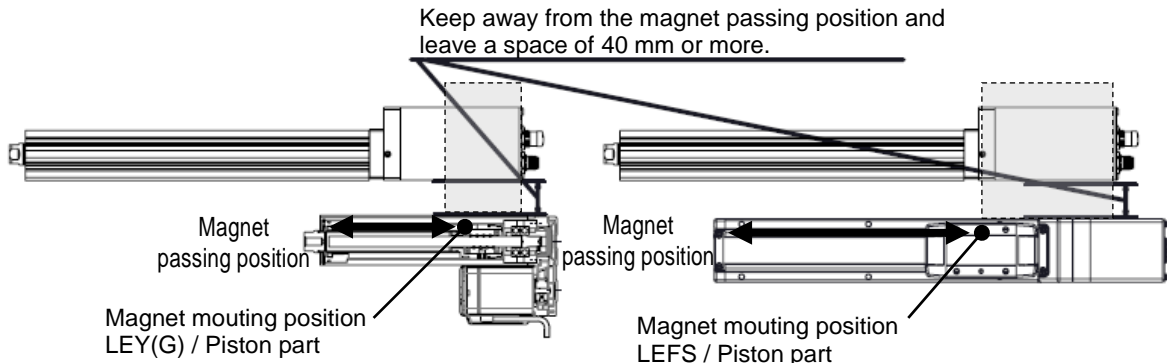
When installing an air cylinder with an auto switch (ex. CDQ2 series) side by side, maintain 40 mm minimum around the motor.



Air cylinder installation with an auto switch is forbidden in the shaded area.

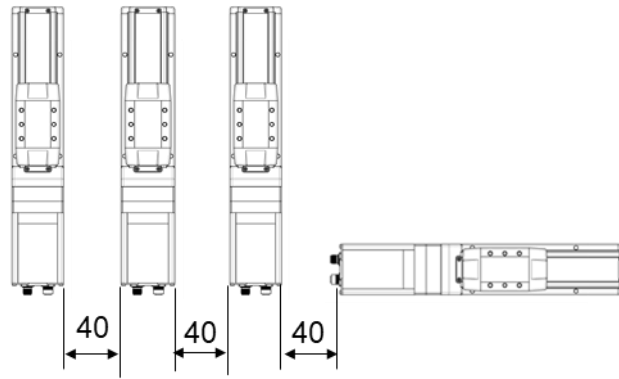
(Example 2)

When installing electric actuator LEY(G) or LEF、EQF、EQY series with an auto switch by side, leave a gap of 40 mm or more with respect to the position where the magnet passes.





The motors of the electric actuator can be installed close to each other.



**⚠ Caution**

**① Supply power when the actuator is stationary.**

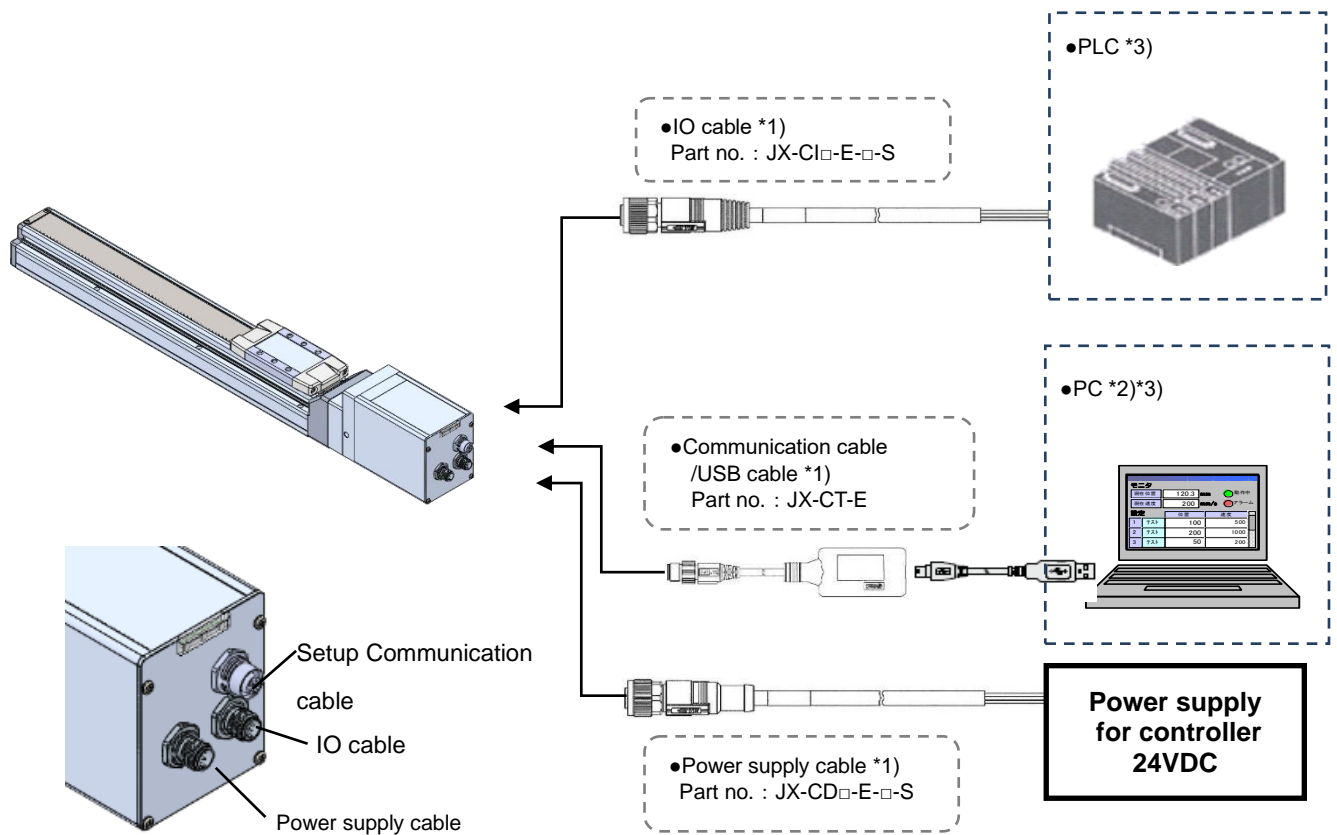
The electric actuator acquires the absolute position data from the absolute encoder when power is applied.

Therefore, if the power is applied to the controller when the actuator is moving with an external force, the controller fails to acquire the absolute position data, which generates an alarm.

# 1 Outlines of Product

## 1.1 System configuration example

An example of a system configuration using the controller is shown below.



\*1 Optional item.

\*2 Latest version of the configuration software must be used.

Also please download it from the SMC website. <https://www.smcworld.com/>

\*3 PLC, PC are prepared by the user.

## 1.2 Features

Features of the electric actuator.

- Electric actuator control

Positioning operation and operation at a specific speed and force of the actuator are possible by controlling the Step motor (24 VDC servo).

- Alarm detection function

Abnormal conditions are automatically detected. Alarms are output via CC-Link communication. The alarm history can be stored in the controller memory.

- Possible to select single solenoid, double solenoid, and closed center modes

Three control modes of the single solenoid, double solenoid, and closed center are provided and a valve control similar to the air cylinder can be specified by selecting the mode.

- Possible to perform the positioning operation to both ends or intermediate point and pushing operation to the end

Control the electric actuator according to the operation data specified by the input of parallel I/O.

It is possible to set up the operation data using setup software.

The positioning to both ends or the pushing operation can be set with single solenoid and double solenoid modes.

Possible to perform the positioning operation to both ends and the intermediate point as well as the pushing operation to the end with the closed center mode.

- OUT output function

The OUT output turns ON when the position of the electric actuator is within the range of the "OUT signal output width" parameter of the target position.

- Data input method

It is possible to perform parameter setup, status monitoring, trial run and alarm reset via the serial communication with a PC installed with the setting software.

- Applicable for the Battery-Less Absolute Encoder

When using the electric actuator compatible with battery-less absolute encoder, detection of the absolute position enables the encoder to detect the actuator position when power is supplied, so operation is available with no return to origin operation.

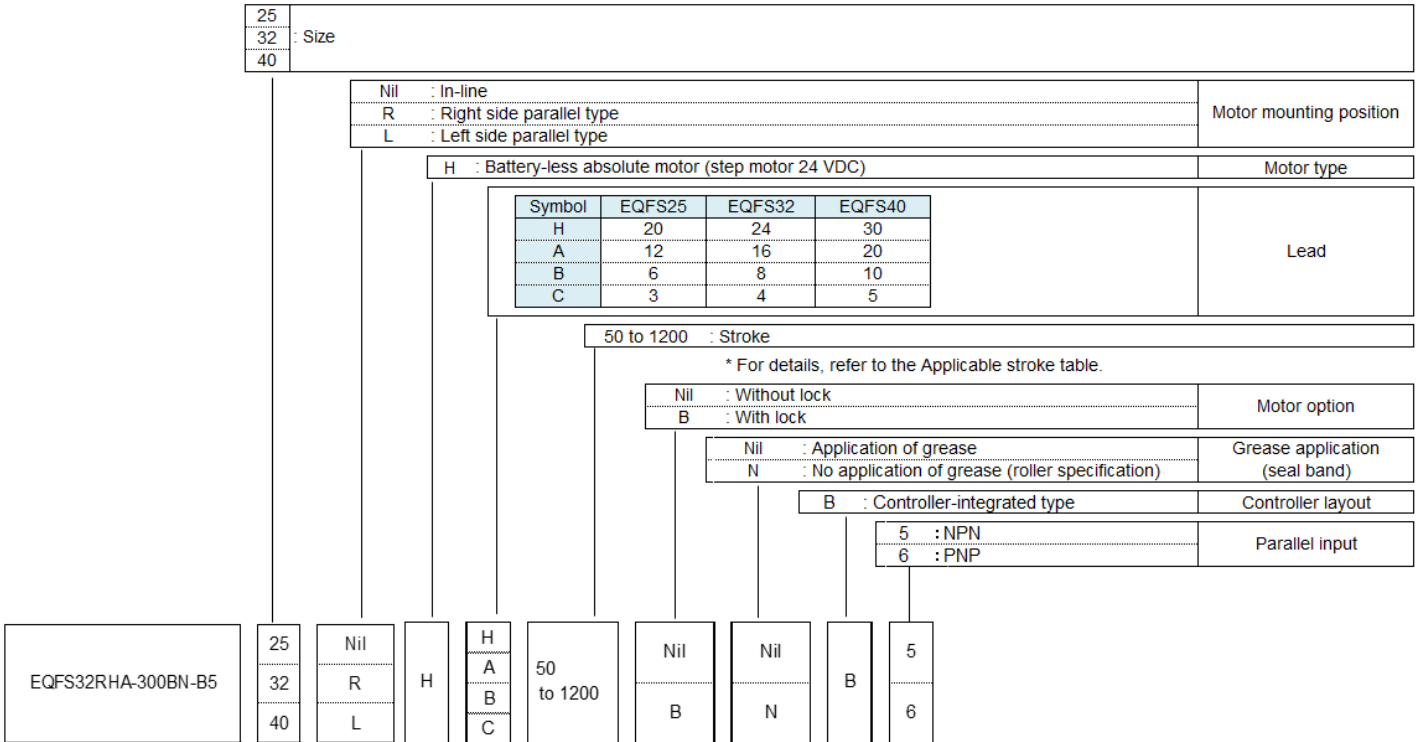
### **Caution**

When the device is set up or failure occurs, please refer the operation manual of software as well as this operation manual.  
Keep this operation manual accessible for reference when necessary.

### 1.3 How to Order

How to order is shown below.

E Q F S 32 R H A - 300     - B 5



#### Applicable stroke table

Size	Stroke [mm]																					
	50	100	150	200	250	300	350	400	450	500	550	600	650	700	750	800	850	900	950	1000	1100	1200
25	●	●	●	●	●	●	●	●	●	●	●	●	●	●	●	●	-	-	-	-	-	-
32	●	●	●	●	●	●	●	●	●	●	●	●	●	●	●	●	●	●	●	●	-	-
40	-	-	●	●	●	●	●	●	●	●	●	●	●	●	●	●	●	●	●	●	●	●

# 1.4 Specification Table

## Battery-less absolute encoder type (Step motor 24 VDC)

Model		EQFS25				EQFS32				EQFS40					
Actuator specification	Stroke[mm] Note1)	50 to 800				50 to 1000				150 to 1200					
	Work load [kg] Note.2)	Horizontal	15	26	40	40	39.5	50	68	68	26	60	75	80	
		Vertical	2	6	12.5	15	4	10	16	20	4.5	4.5	25	40	
	Speed[mm/s]	Stroke Range	to 400	20 to 1200	12 to 850	6 to 450	3 to 225	24 to 1100	16 to 750	8 to 450	4 to 125	30 to 1200	20 to 1000	10 to 500	5 to 225
			401 to 500	20 to 1100	12 to 750	6 to 400	3 to 225	24 to 1100	16 to 750	8 to 450	4 to 125	30 to 1200	20 to 1000	10 to 500	5 to 225
			501 to 600	20 to 900	12 to 540	6 to 270	3 to 135	24 to 1100	16 to 750	8 to 400	4 to 125	30 to 1200	20 to 1000	10 to 500	5 to 225
			601 to 700	20 to 630	12 to 420	6 to 230	3 to 115	24 to 930	16 to 620	8 to 310	4 to 125	30 to 1200	20 to 900	10 to 440	5 to 220
			701 to 800	20 to 550	12 to 330	6 to 180	3 to 90	24 to 750	16 to 500	8 to 250	4 to 125	30 to 1140	20 to 760	10 to 350	5 to 175
			801 to 900	-	-	-	-	24 to 610	16 to 410	8 to 200	4 to 100	30 to 930	20 to 620	10 to 280	5 to 140
			901 to 1000	-	-	-	-	24 to 500	16 to 340	8 to 170	4 to 85	30 to 780	20 to 520	10 to 250	5 to 125
			1001 to 1100	-	-	-	-	-	-	-	-	30 to 660	20 to 440	10 to 220	5 to 110
	1101 to 1200	-	-	-	-	-	-	-	-	30 to 570	20 to 380	10 to 190	5 to 95		
	Max. acceleration/deceleration [mm/s <sup>2</sup> ]	Horizontal	10000												
		Vertical	5000												
	Positioning repeatability [mm]		±0.02												
Lost motion[mm] Note3)		0.1 or less													
Lead [mm]		20	12	6	3	24	16	8	4	30	20	10	5		
Impact/Vibration resistance [m/s <sup>2</sup> ] Note.4)		50/20													
Actuation type		Ball screw (EQFS□), Ball screw and belt (EQFS□/L)													
Guide type		Linear Guide													
Operating temperature [°C]		5 to 40													
Operating humidity [%RH]		90 or less (No condensation)													
Electric specification	Motor size	□42				□56.4									
	Motor type	Battery-less Absolute(Step motor 24VDC)													
	Encoder	Battery-less Absolute													
	Powre supply voltage [V]	24DC±10%													
	Power [W] Note.5) Note.7)	Max. 89				Max. 116				Max. 116					
Lock unit specifications	Type Note.6)	Non-magnetizing lock													
	Holding force [N]	47	78	157	294	72	108	216	421	75	113	225	421		
	Power [W] Note.7)	5				5				5					
	Powre supply voltage [V]	24DC±10%													

Note 1) Non-standard strokes are available as special orders, so please contact SMC .

Note2) Maximum payload at acceleration/deceleration of 3000mm/s<sup>2</sup>.

Work load varies depending on the velocity and acceleration. Please refer to the catalog for the "speed - payload graph".  
Furthermore, if the cable length exceeds 5 m, then it will decrease by up to 10% for each 5 m.

Note3) A reference value for correcting an error in reciprocal operation.

Note4) Impact resistance: In a drop impact test, no malfunction occurred in the axial direction and perpendicular direction of the feed screw.  
(Value at the initial stage)

Vibration resistance: 45 to 2000 Hz 1 sweep, no malfunction in the axial direction and perpendicular direction of the feed screw.  
(Value at the initial stage)

Note5) Power indicates the maximum power during operation including the controller. Use this when selecting the power supply capacity.

Note6) Only applies to actuators supplied with a lock.

Note7) For the actuator with lock, please add the power consumption for the lock.

## Product weight

Series	EQFS25 (Motor mounting position: I-line)															Additional weight with lock	
Stroke[mm]	50	100	150	200	250	300	350	400	450	500	550	600	650	700	750	800	
Weight[kg]	1.77	1.91	2.05	2.19	2.33	2.47	2.61	2.75	2.89	3.03	3.17	3.31	3.45	3.59	3.73	3.87	0.31

Series	EQFS32 (Motor mounting position: I-line)																Additional weight with lock				
Stroke[mm]	50	100	150	200	250	300	350	400	450	500	550	600	650	700	750	800	850	900	950	1000	
Weight[kg]	3.12	3.32	3.52	3.72	3.92	4.12	4.32	4.52	4.72	4.92	5.12	5.32	5.52	5.72	5.92	6.12	6.32	6.52	6.72	6.92	0.58

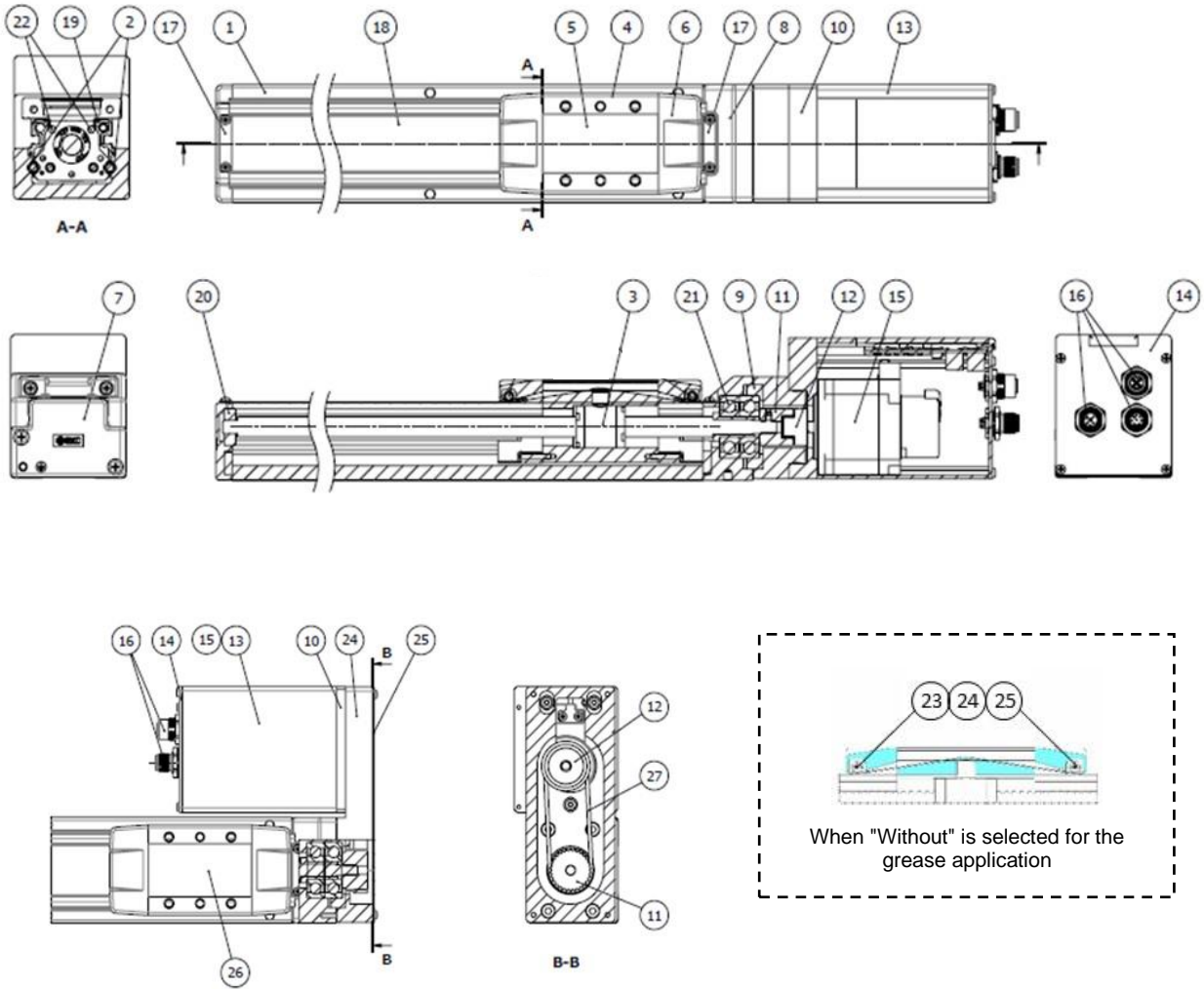
Series	EQFS40 (Motor mounting position: I-line)																Additional weight with lock				
Stroke[mm]	150	200	250	300	350	400	450	500	550	600	650	700	750	800	850	900	950	1000	1100	1200	
Weight[kg]	4.99	5.27	5.55	5.83	6.11	6.39	6.77	6.95	7.23	7.51	7.79	8.07	8.35	8.63	8.91	9.19	9.47	9.75	10.31	10.87	0.6

Series	EQFS25(L/R) (Motor mounting position: Parallel type)															Additional weight with lock	
Stroke[mm]	50	100	150	200	250	300	350	400	450	500	550	600	650	700	750	800	
Weight[kg]	1.75	1.89	2.03	2.17	2.31	2.45	2.59	2.73	2.87	3.01	3.15	3.29	3.43	3.57	3.71	3.85	0.31

Series	EQFS32(L/R) (Motor mounting position: Parallel type)																Additional weight with lock				
Stroke[mm]	50	100	150	200	250	300	350	400	450	500	550	600	650	700	750	800	850	900	950	1000	
Weight[kg]	3.09	3.29	3.49	3.69	3.89	4.09	4.29	4.49	4.69	4.89	5.09	5.29	5.49	5.69	5.89	6.09	6.29	6.49	6.69	6.89	0.58

Series	EQFS40(L/R) (Motor mounting position: Parallel type)																Additional weight with lock				
Stroke[mm]	150	200	250	300	350	400	450	500	550	600	650	700	750	800	850	900	950	1000	1100	1200	
Weight[kg]	5.15	5.43	5.71	5.99	6.27	6.55	6.83	7.11	7.39	7.67	7.95	8.23	8.51	8.79	9.07	9.35	9.63	9.91	10.47	11.03	0.6

# 1.5 Construction



**Component Parts**

No.	Description	Material	Remarks
1	Body	Aluminum alloy	Anodized
2	Rail Guide	-	
3	Ball screw assembly	-	
4	Table	Aluminum alloy	Anodized
5	Blanking plate	Aluminum alloy	Anodized
6	Seal band hold down	Synthetic resins	
7	Housing A	Aluminum Die Casting	Coating
8	Housing B	Aluminum Die Casting	Coating
9	Bearing stopper	Aluminum alloy	
10	Motor adapter	Aluminum alloy	Coating
11	Hub/Pulley	Aluminum alloy	
12	Hub/Pulley	Aluminum alloy	
13	Motor cover	Aluminum alloy	Anodized

No.	Description	Material	Remarks
14	End cover	Aluminum alloy	Anodized
15	Motor	-	
16	Connector	-	
17	Band stopper	Stainless steel	
18	Dust Seal Band	Stainless steel	
19	Seal magnet	-	
20	Bearing	-	For 201 strokes or more
21	Bearing	-	
22	Magnet	-	
23	Roller shaft	Stainless steel	When "Without" is selected for the grease application

**Components (parallel motor only)**

No.	Description	Material	Remarks
24	Return Plate	Aluminum alloy	Coating
25	Cover plate	Aluminum alloy	Anodized
26	Table spacer	Aluminum alloy	Anodized
27	Belt	-	

**Replacement Parts (parallel motor only)/Belt**

No.	Size	Order No.
27	25	LE-D-15-1
	32	LE-D-19-1
	40	LE-D-19-2

**Replacement parts/Grease pack**

Applied portion	Order No.
Ball screw	GR-S-010(10G) GR-S-020(20G)
Rail guide	
Dust seal band (When "Without" is selected for the grease application, grease is applied only on the back side.)	

## 1.6 Accessories

### Table spacer (Parallel motor only)

Model	Part name	QTY
EQFS25(L/R)	Table spacer	1
EQFS32(L/R)		
EQFS40(L/R)		

### Optional parts (sold separately)

- Power supply cable
- Parallel I/O cable
- Communication cable
- USB cable
- Setup software

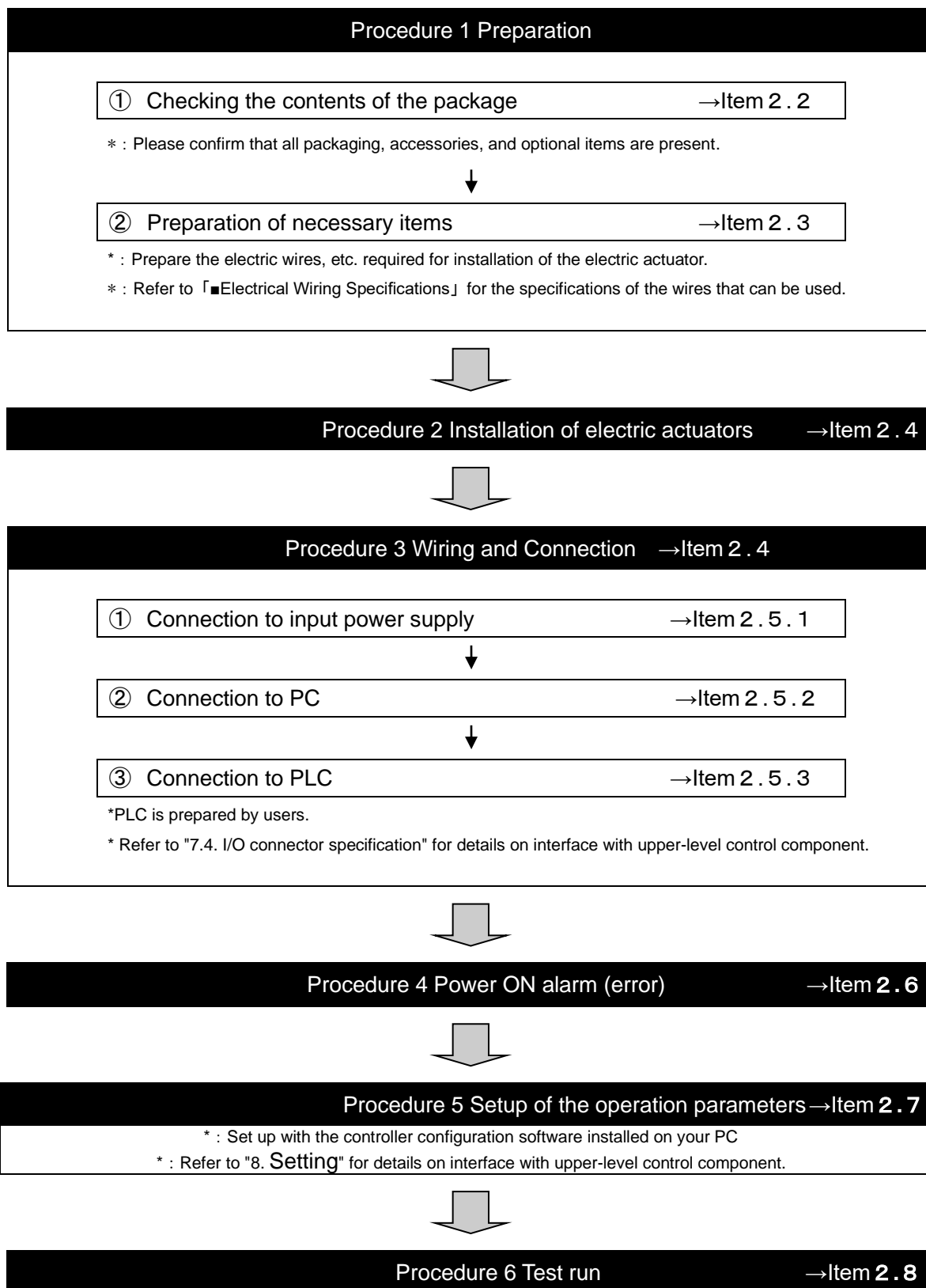
Refer to **9 Optional parts (sold separately)** for details of optional parts.



## 2 Installation and Initial Setting

### 2.1 Flow from installation to initial setting

Be sure to check the procedure below before use.

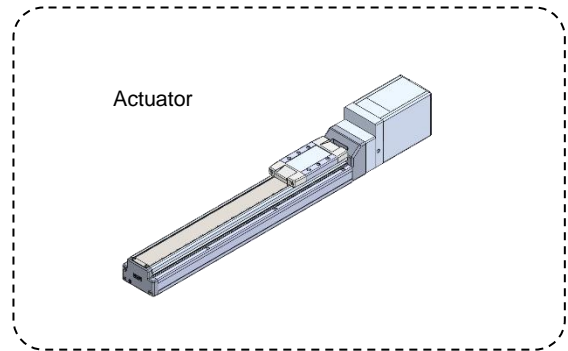


## 2.2 Check the contents of the packag

After unpacking everything, check the description on the label to identify the actuator and the number of accessories. If any parts are missing or damaged, please contact your distributor.

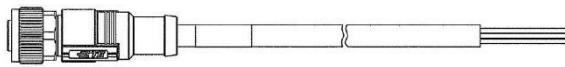
Product Name and Number	Quantity
Electric actuator (EQFS□)	1 pcs.
Table spacer *1)	1 pcs.

\*1) Parallel motor only

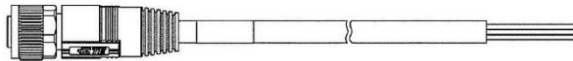


### 【Optional parts】 (sold separately)

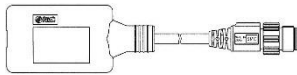
- Power supply cable



- I/O cable



- Setup communication cable



- USB cable



- Setup software

Please download it from the SMC website. <https://www.smcworld.com/>

## 2.3 Preparation of necessary supplies

Please prepare the following items for installation and wiring.

- Wiring cable
- M4 screw
- Cable with crimping terminal
- Toothed washer
- Switch (24 VDC, contact capacity of 0.5 A or more) : For lock release

Please provide the following equipment to run the system.

- 24 VDC power supply
- PC
- PLC

## 2.4 Installation of electric actuators

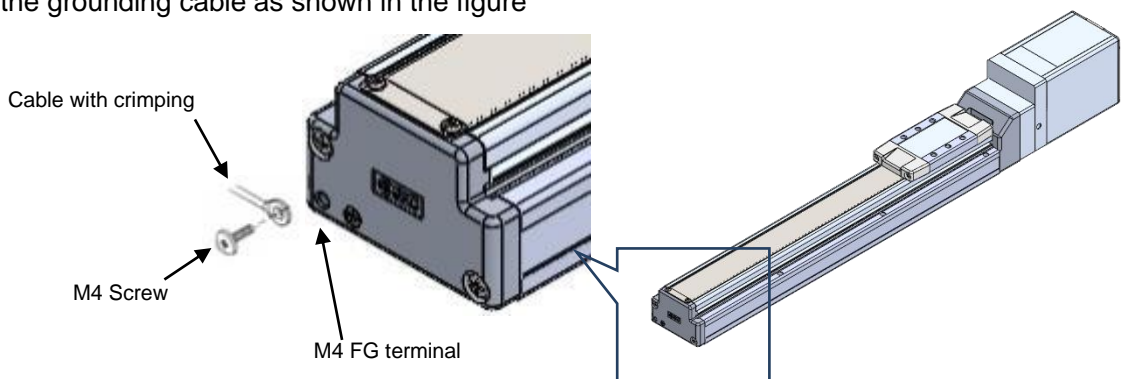
Install the electric actuator at the installation location using the following method.

### (1) Mounting

Refer to [Electric actuators / Common precautions](#) in [Precautions for product specific](#) for information on bolts and fastening torques to be used for mounting workpieces and tools and for mounting the main unit.

### (2) Connection to ground

Install the grounding cable as shown in the figure



### ⚠ Caution

M4 screw, the cable with crimped terminal and toothed washer must be prepared by the user. The actuator must be connected to Ground to reduce noise. If further noise resistance is required, consider measures such as grounding 0V (signal ground).

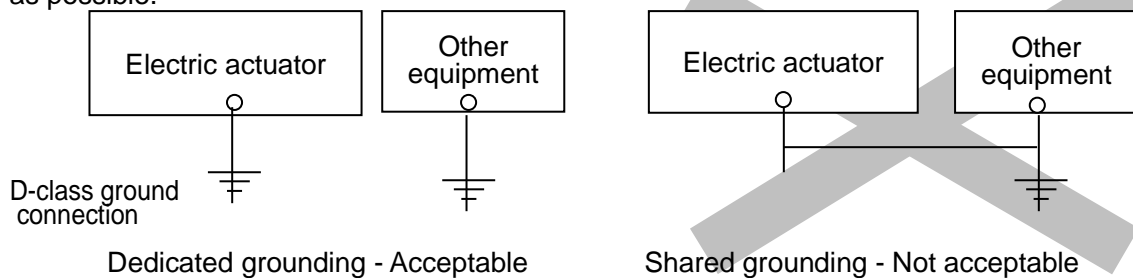
When grounding the 0V, avoid flowing noise from the ground to the 0V.

### ⚠ Caution

The earth should be a dedicated earth connection. Use a D-class ground connection (ground with a resistance of less than  $100\Omega$ ).

The cross sectional area of the grounding cable shall be  $2\text{mm}^2$  minimum.

The Grounding point should be as near as possible to the actuator. Keep the grounding cable as short as possible.

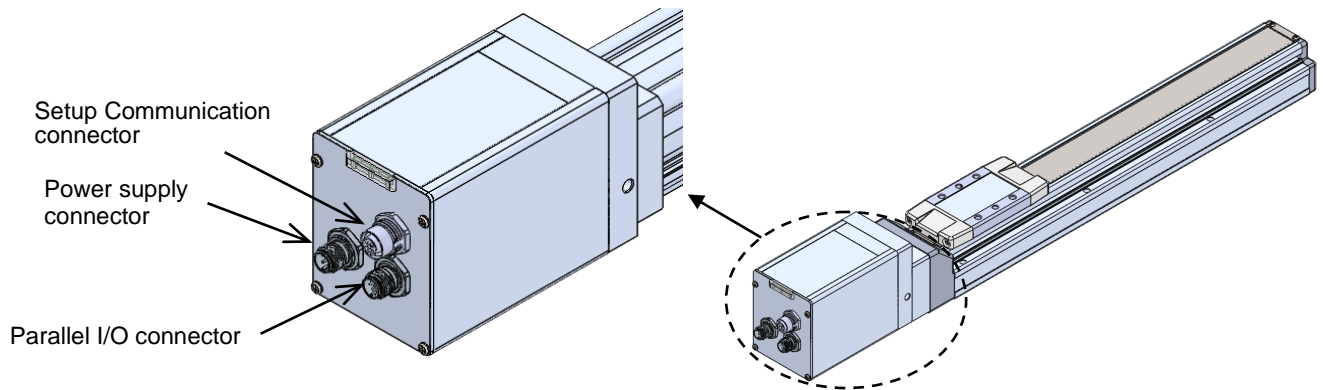


### (3) Precautions for electric actuator compatible with battery-less absolute encoder installation

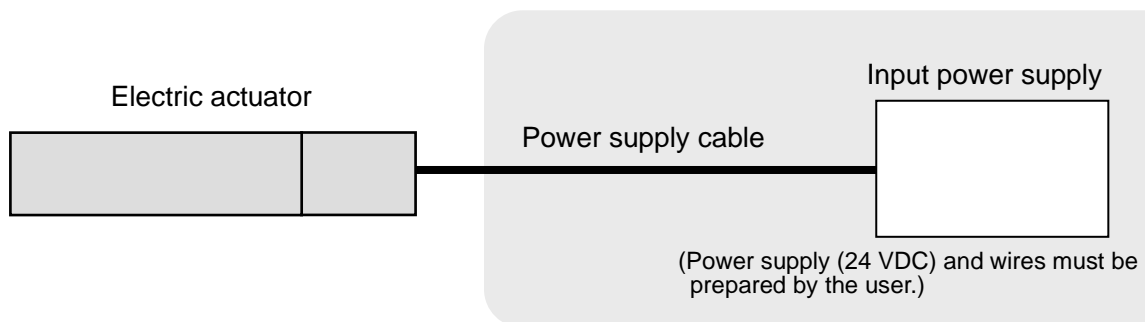
Please refer to [Precautions for product specific](#) of [Individual precautions for battery-less absolute encoder](#).

## 2.5 Wiring and Connection

Please prepare electric actuator. Connect the cable to the connector part of the electric actuator.



### 2.5.1 Connection to input power supply



#### **⚠ Caution**

Do not use an inrush current limited type of power supply.

#### (1) Wiring of the power supply cable

Connect the power supply cable to the 24VDC power supply according to instructions 1) ,2) and 3) and then insert it into the connector of the actuator.

#### **⚠ Caution**

Arrange wiring so that conduct of each wire do not contact other lines.

#### 1) Wiring of power supply (C24V, M24V, 0V)

Connect the positive side (+) of the actuator input power supply 24VDC to the C24V and M24V electric wire of the power supply cable and connect the negative (-) to the 0V electric wire.

#### **⚠ Caution**

Do not use a power supply with "inrush-current control" for the power supply.

## 2) Wiring of the stop switch (EMG)

When applying 24V to M24V electric wire, the product starts operating. When 24V is shut off, Servo OFF activates and the product stops operating. Stop switch must be installed by the user to stop the actuator in abnormal situations for this M24V wire.

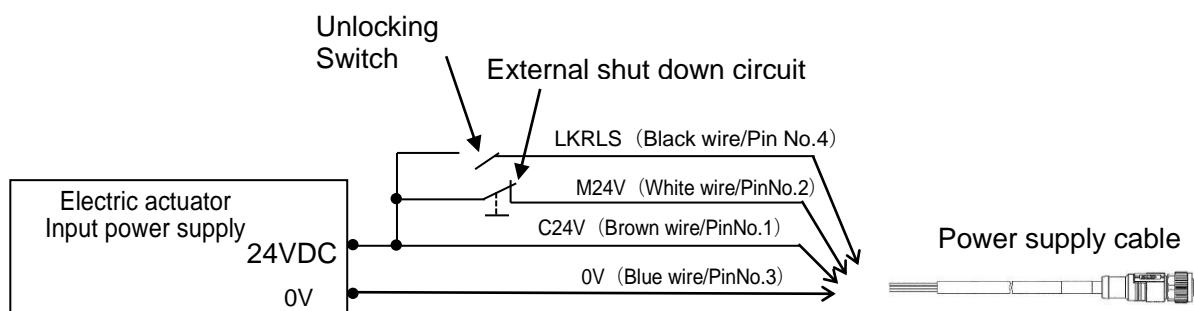
Refer to ■ **Wiring of shutdown circuit** for wiring.

## 3) Wiring of the lock release (LK RLS)

Install an unlocking switch for adjustment or recovery during an emergency of the locking actuator.

\* The switch (24V DC, contact capacity: 0.5A or more) needs to be prepared by the user.

One terminal of the lock release switch should be connected to the 24VDC power supply and the other should be connected to the LK RLS electric wire. When this is switched on, the lock will be released.



### ⚠ Caution

It is unnecessary to connect LK RLS terminal when the actuator does not have locking mechanism.

The LK RLS electric wire is only used for adjustment and emergency return. It must not be energized during normal operation.

After wiring the power supply plug, connect it to power connector of the actuator.

## (2) Wiring of shutdown circuit

Design the circuit so that M24V is turned off when the stop switch and ALARM are turned off.

(see P.36 Fig.1-1 and Fig.1-2 for circuit example)

Operation resumes when the stop is released. Please release the stop after fully confirming safety.

The operation when the stop is released differs depending on the mode.

Please check the following.

### Operation when stop is released.

#### ●For single solenoid mode

Operation starts according to the state of the IN1 signal.

When IN1 is OFF: Moves to the home end. When IN1 is ON: Move to the opposite end.

#### ●For double solenoid mode

Executes IN0 or IN1 that was input immediately before releasing the stop.

If IN0 and IN1 are not changed while M24V is OFF, the operation before the stop switch (or ALARM) was turned off will resume.

If the operation is not restarted immediately after the stop is released, shut off the C24V as well as the M24V. (see P.37 Fig.2-1 and Fig.2-2 for circuit example)

If the C24V is shut off when stopped, the operation will start when IN0 or IN1 turns ON after the stop is released.

#### ●For closed center mode

It operates according to the state of the IN0 and IN1 signals.

If you do not restart the operation after releasing the stop, release the stop while both IN0 and IN1 are OFF.

IN0	IN1	Operation when stop is released
ON	OFF	Move to origin end
OFF	ON	Move to opposite end
ON	ON	Move to intermediate position
OFF	OFF	Stop

### Caution

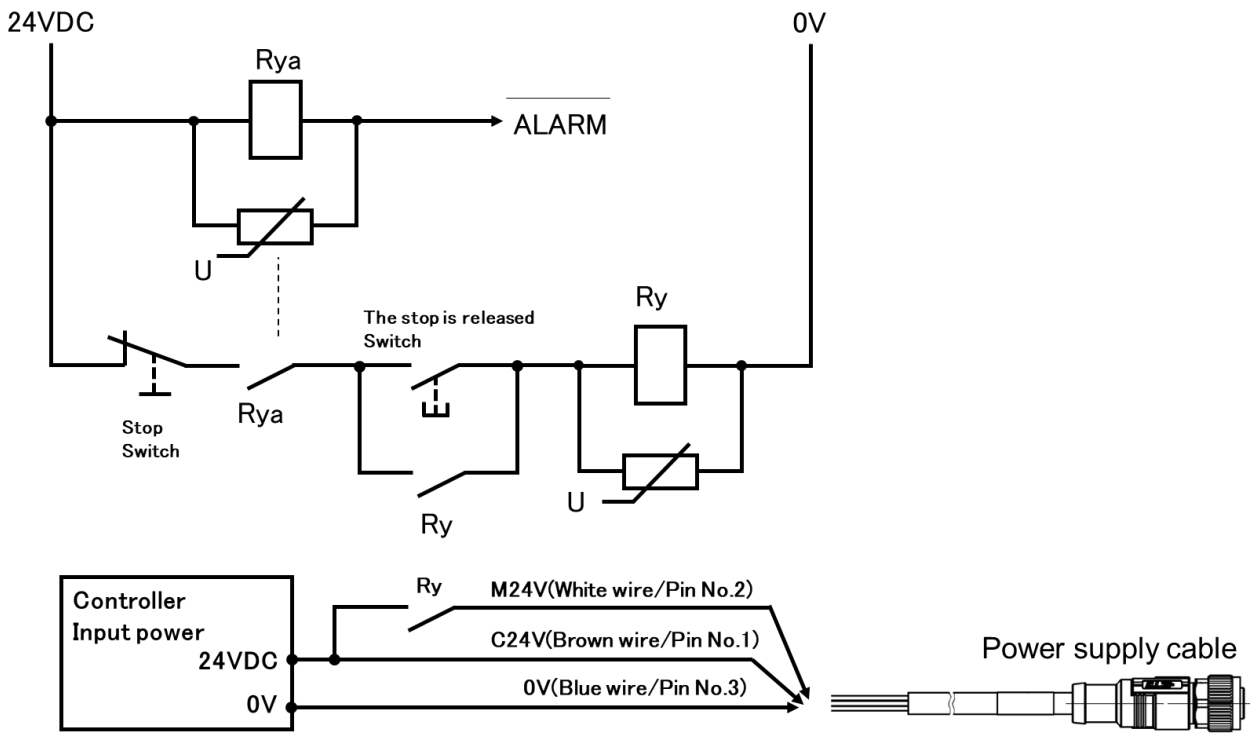
When shutdown is input, the actuator stops with maximum deceleration, then the motor is turned OFF.

### Warning

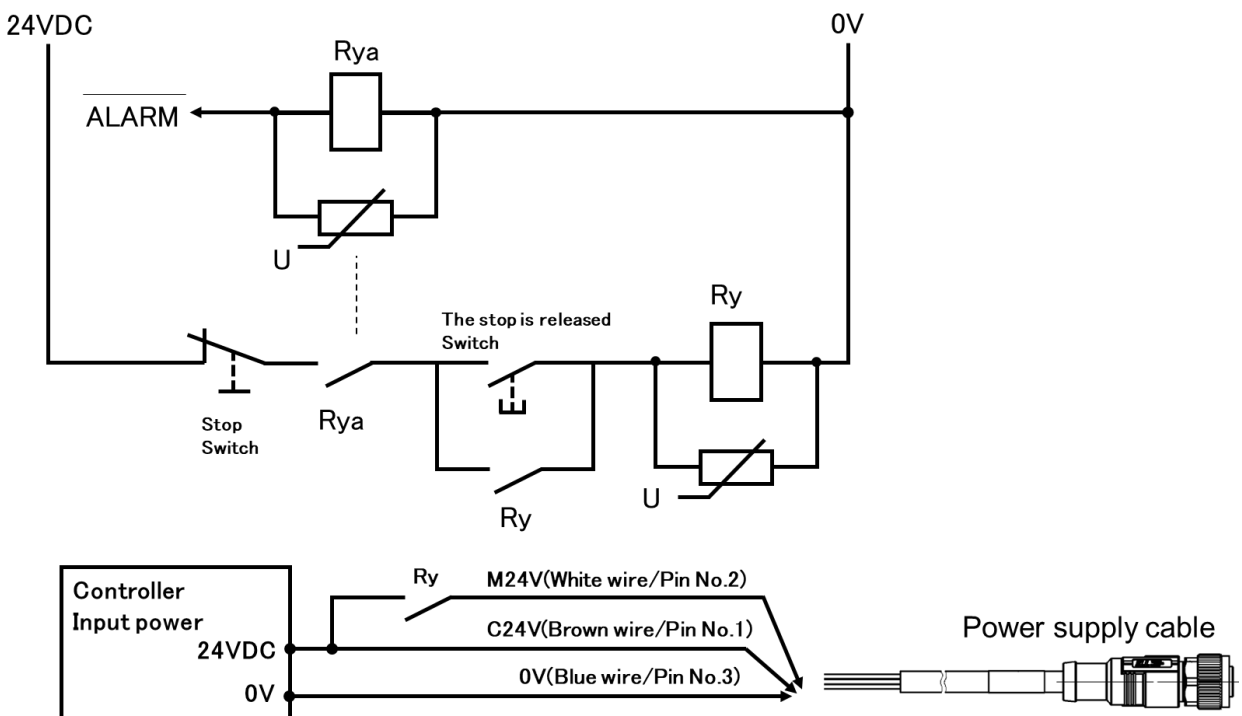
If an electric actuator with lock is used vertically, delay in response of the Lock may occur when shutting off the motor power supply (M24V), and the moving part of the actuator may drop due to the weight of the actuator itself.



**Fig.1-1 Circuit example(for NPN type)**

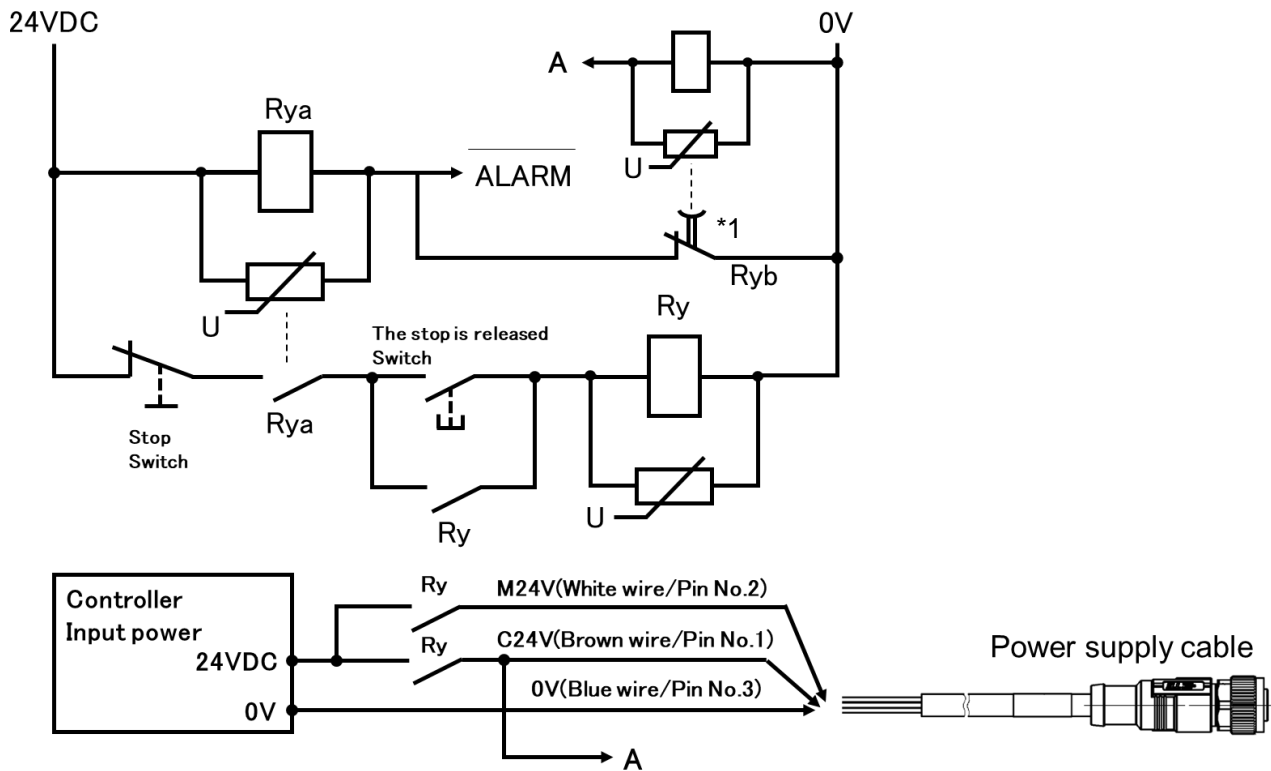


**Fig.1-2 Circuit example(for PNP type)**



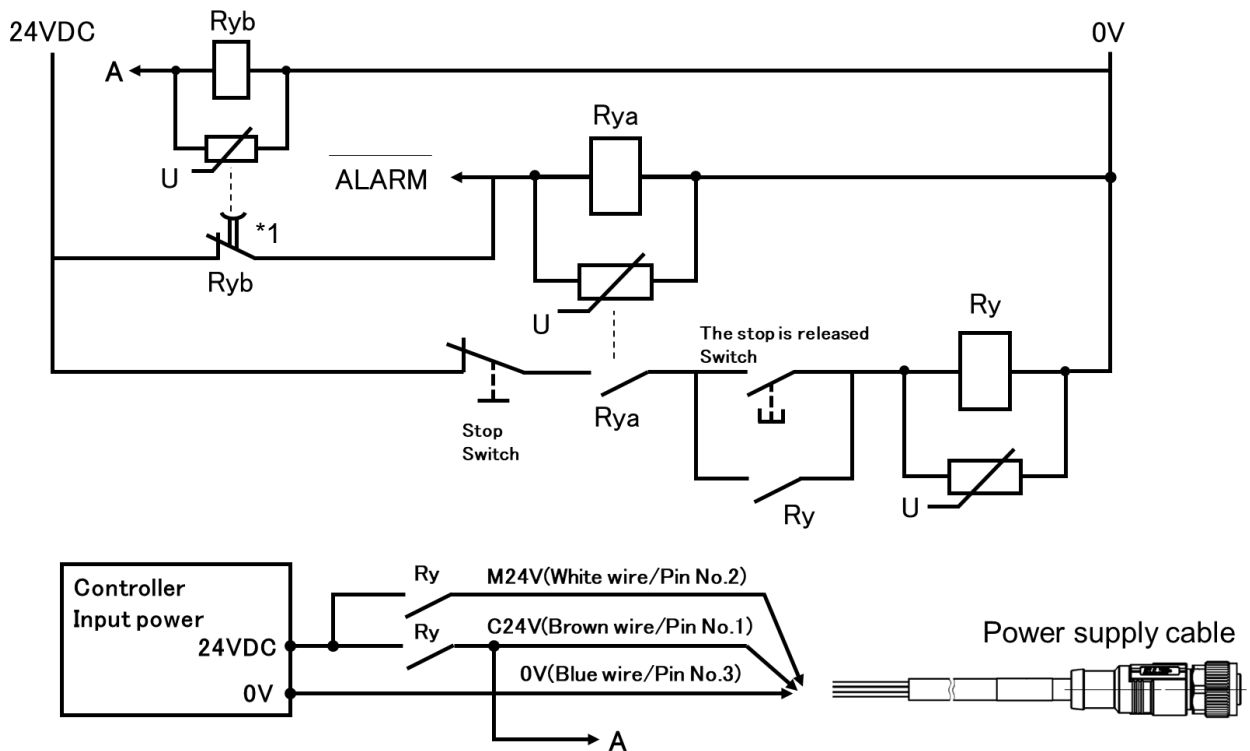
**Fig. 2-1 Circuit example (for NPN type)**

Example where operation is not restarted when double solenoid mode stop is released.



**Fig. 2-2 Circuit example (for PNP type)**

Example where operation is not restarted when double solenoid mode stop is released)



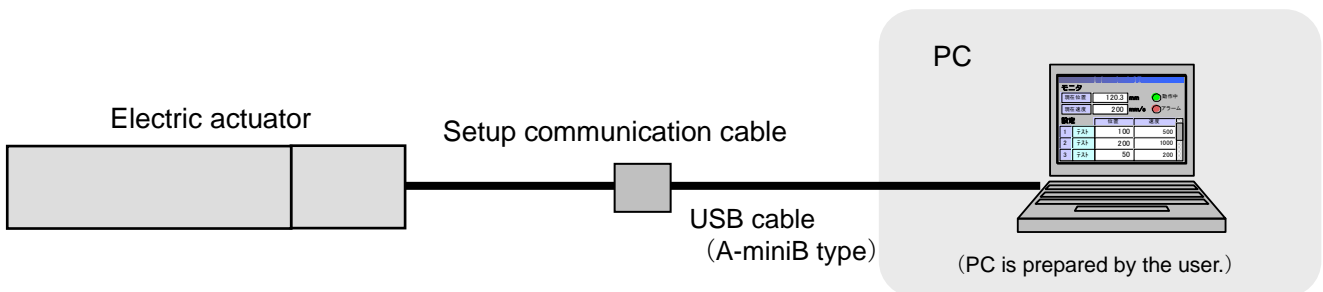
Set the timer setting value to 0.5 seconds or more.  
 Also, add the delay time such as the rise time of the 24V power supply specification to the timer setting value.  
 e.g. If the delay time of the 24V power supply is 1.0 seconds, the timer setting value will be: 1.5 (=0.5+1.0) seconds or more.

## 2.5.2 Connection to PC

---

Connect the setup communication cable to the communication connector of the electric actuator and the PC.

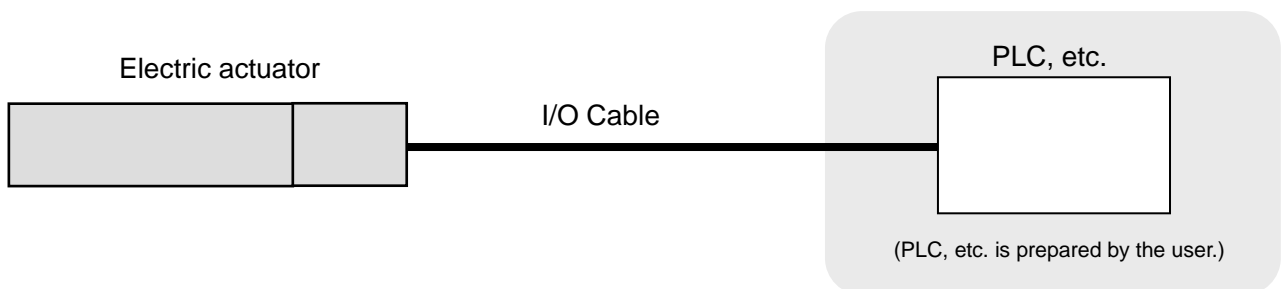
- Setup communication cable part number (with A-miniB type USB cable): JX-CT-E



## 2.5.3 Connection to PLCs, etc

---

Connect the I/O cable to the I/O connector part of the electric actuator and the PLC, etc.



Refer to "[7.4 I/O connector specification](#)" for details on parallel input/output and parallel input/output signals.

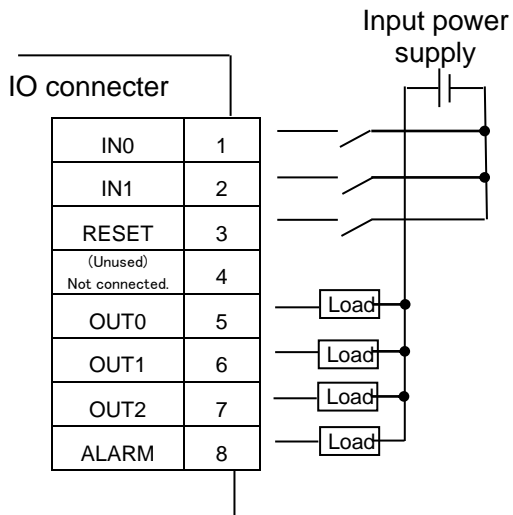
### ■ I/O Wiring Example

Use the I/O cable (JX-CI□-E-□-S) for connecting a PLC with the I/O connector.

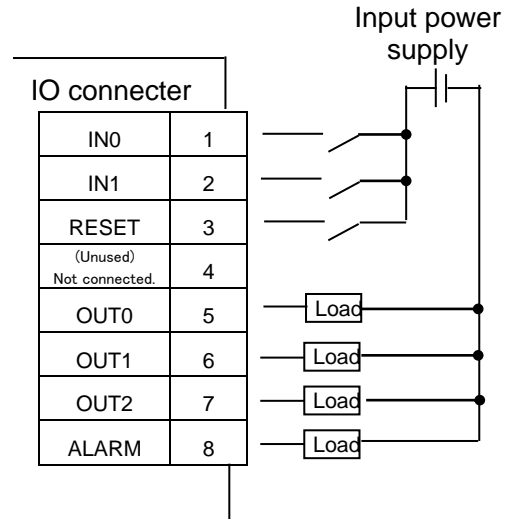
Wiring depends on the parallel input/output type of the actuator (NPN or PNP).

Perform wiring referring to the wiring diagram below.

●NPN type



●PNP type

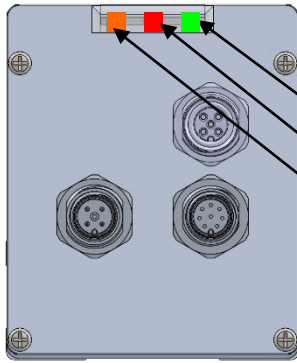


**! Caution**

The parallel input/output of this electric actuator is of non-insulated specification.  
Use the same power supply as the control power supply C24V for the parallel input/output power.

## 2.6 Power ON alarm (error)

Check that there is no problem with each wiring referring to 2.5 Wiring and connection of electric actuator and supply 24 VDC power supply between C24V - 0V (power supply input for control) and between M24V - 0V (power supply input for power line) of the power supply cable.



Electric actuator

LED	LED status	Status
PWR (Green)	ON	Normal
ALM (Red)	OFF	No alarms
OVL(Orange)	OFF	No Overload warning

If the LED [PWR] on the electric actuator turns green, it is in normal condition.

If the LED [ALM] on the electric actuator turns red, the alarm is generated.

\*If the LED [PWR] on the electric actuator is turned off, the voltage between M24V - 0V is low or 0 VDC.

\*If the LED [OVL] on the electric actuator turns orange, the electric actuator operation may be in an overloaded condition.

### ! Caution

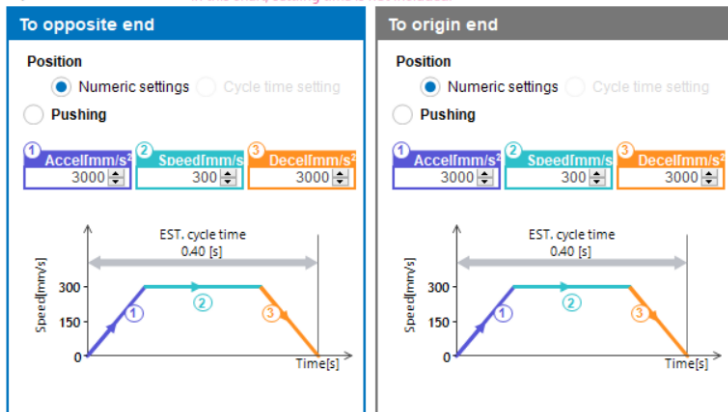
When an alarm is generated, connect the setup software to the setup communication connector of the electric actuator, check the alarm details, and solve the cause referring to **5. Alarm Detection**. Refer to the operation manual of the setup software for the alarm checking method.

## 2.7 Setup of the operation parameters

Set the operating data and parameters with the setting software.

### ●Setting Software

Operation condition \* In this chart, settling time is not included.



Refer to the operation manual of the setting software for the setup method.

## ■ Settings and Data Entry

Setup of the operation data is required using the setup software to move the electric actuator to the specified position. The data entered using the setup software is stored in the memory of the electric actuator.

Three types of control modes that provide control similar to an air cylinder are available with this electric actuator, which could be used according to the purpose and preference.

Select from the three modes described below using the setup software.

The setting at the time of shipment is set at "**Closed center mode**" as default.

- Single solenoid mode

The electric actuator can be controlled similar to controlling a single solenoid valve.

Moves to the opposite end when the IN1 input signal is turned ON and moves to the origin end when turned OFF.

Positioning operation to both ends or pushing operation is possible.

### Warning

In the single solenoid mode, note that the operation will immediately start after the actuator input power is supplied when the stop position is at a position other than the origin end or the opposite end.

- Double solenoid mode

The electric actuator can be controlled similar to controlling a double solenoid valve.

Moves to the origin end when the IN0 input signal is turned ON and moves to the opposite end when the IN1 input signal is turned ON.

Positioning operation to both ends or pushing operation is possible.

- Closed center mode

The electric actuator can be controlled similar to controlling a closed center valve.

Moves to the origin end when IN0 input signal is turned ON (IN1 input signal is turned OFF).

Moves to the opposite end when the IN1 input signal is turned ON (IN0 input signal is turned OFF).

Moves to the intermediate position when both IN0 input signal and IN1 input signal are turned ON.

The positioning operation to both ends and the intermediate position as well as the pushing operation to both ends are possible.

Refer to [8 Setting](#) for details of the operation data and parameters.

## 2.8 Test run

Test run to ensure that the electric actuator is operating properly in the system.

Refer to the operation manual of the setting software for how to perform a trial run.

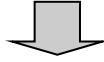
## 3 Operation

### 3.1 Operation flow

The startup procedure varies depending on the power-on situation.

#### Procedure1 Startup

- When turning on the power supply normally after shipped from SMC
- When supplying power again after resetting the alarm Group E or after changing the parameter of "return to the origin direction"



#### Procedure 2 Operation Instructions

- |                          |             |
|--------------------------|-------------|
| ① Positioning operation  | →Item 3.3.2 |
| ② Reset                  | →Item 3.3.3 |
| ③ Interrupting operation | →Item 4.4   |

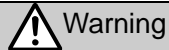
## 3.2 Procedure for power set up

### 3.2.1 Procedure for power start up

The following is a Startup procedure for the battery-less absolute encoder for every occasion that occurs when the power is applied

- (1) **When turning on the power supply normally after shipped from SMC**
- (2) **When supplying power again after resetting the alarm Group E due to power supply shutdown or after changing the parameter of "return to the origin direction"**

\*Return to the origin is required. Return to the origin is performed as the first operation command after turning on the power supply.



Warning

The operation for the return to the origin is performed after resetting the Group E alarm and when the operation command is given as the first IN0, IN1 after changing the "return to the origin direction" parameter followed by the content of the operation command.

### 3.2.2 Power Supply Startup

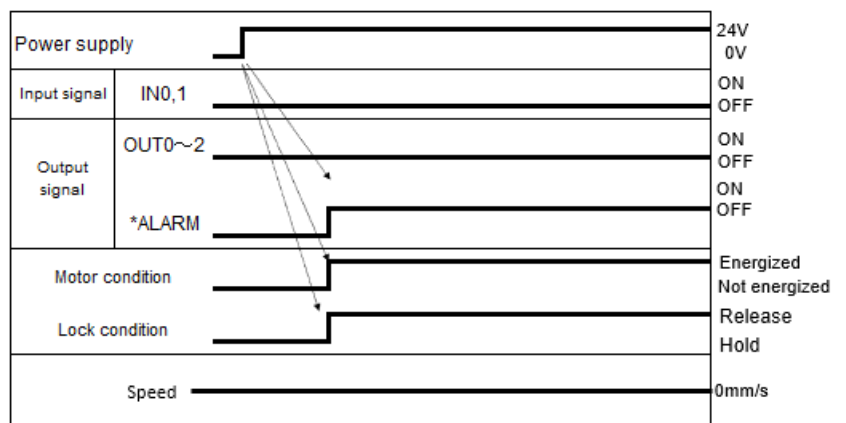
- (1) **When turning on the power supply after shipped from SMC**

The operation preparation is complete if "\*\*ALARM" is turned ON (no alarm) when the power supply is turned on again.

#### - Procedure -

1. Turn on the power supply
- ↓
2. \*Possible to provide operation command by IN0 and IN1 when the ALARM output is turned ON and servo is turned ON.

#### -Timing chart-



\*\*\*Alarm" and \*\*ESTOP" are displayed in negative logic.

## Caution

When the slider is not at the origin end position in the single solenoid mode, it moves to the origin end by turning OFF for IN1 input.

- (2) **When supplying power again after resetting the alarm Group E or after changing the parameter of "return to the origin direction"**



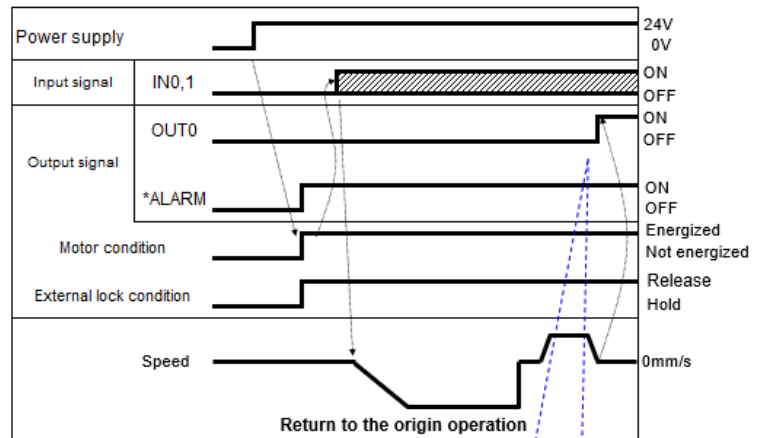
Return to the origin operation is required when the alarm Group E is generated and the alarm is reset due to power supply shutdown or when the "return to the origin direction" parameter is changed.

**- Procedure -**

1. Turn on the power supply
  - ↓
2. \*Turn the ALARM output ON and the servo ON.
  - \*The lock will be released for the actuator with a lock.
  - ↓
3. Turn the IN0 input or IN1 input ON
  - (Performs the return to the origin operation.)
  - \*Return to the origin operation is performed as the first operation command after resetting the alarm Group E or after the "return to the origin direction" parameter is changed.
  - ↓
4. OUT0 output is ON
  - Return to the origin completed.

Possible to provide operation command by IN0 and IN1.

**-Timing chart-**



\*The "\*ALARM" is displayed in negative logic.

ON when return to the origin is completed.

**⚠ Warning**

The operation for the return to the origin is performed after resetting the Group E alarm and when the operation command is given as the first IN0, IN1 after changing the "return to the origin direction" parameter followed by the content of the operation command.

### 3.3 Operation Instructions

#### 3.3.1 Outline of operation command

Operation command can be provided by the operation data pre-registered in the electric actuator using the parallel I/O signal.

The operation procedure differs according to the control mode.

There are two operation patterns with the operation data.

- Positioning operation
- Pushing operation

There are three control modes.

- Single solenoid mode
- Double solenoid mode
- Closed center mode

The operation procedures are described below.

#### 3.3.2 Positioning operation

##### (1) Positioning operation by single solenoid mode

###### - Procedure (Single solenoid mode) -

1. Specify and command operation using the operation data by turning IN1 input ON/OFF.  
⇒ Load the specified operation data.

IN1: ON → Command to move to the opposite end  
 IN1: OFF → Command to move to the origin end

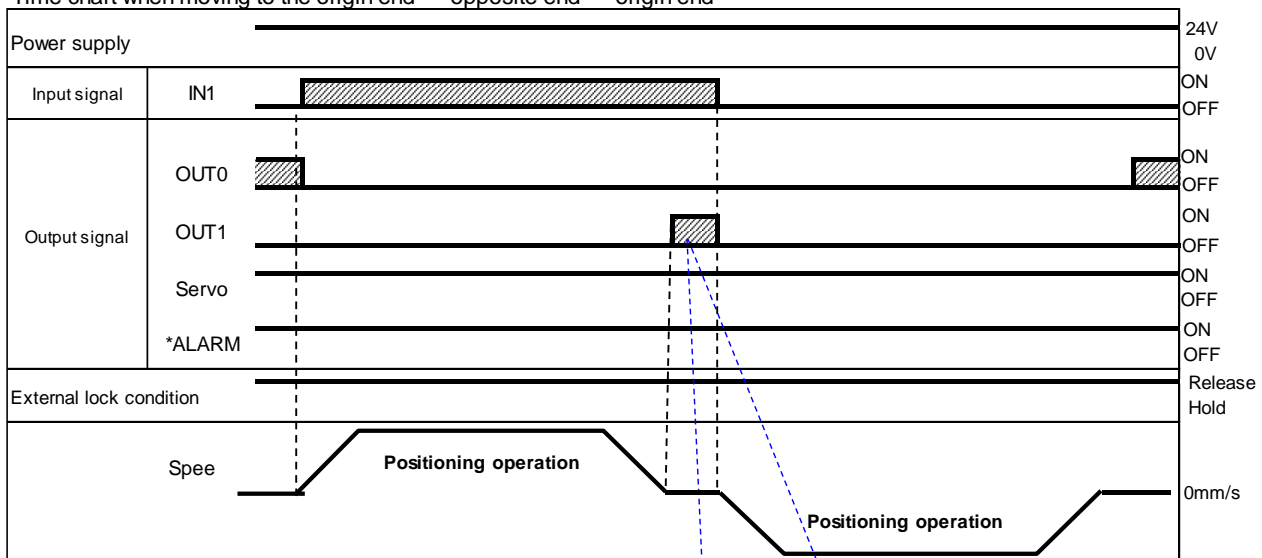
2. Start the positioning operation.

3. When reaching the target position, OUT \*output corresponding to the operation data turns ON.  
The positioning operation is completed.

OUT0 output: ON → Completes the move to the origin end  
 OUT1 output: ON → Completes the move to the opposite end

###### - Timing chart Positioning operation (Single solenoid mode) -

Time chart when moving to the origin end → opposite end → origin end



\*The "\*"ALARM" is displayed in negative logic.

\*\*"Power ON" in the timing chart shows the power supply is turned ON.

\*\*"Servo ON" shows that power is supplied to the motor and it is operable.

\* If the IN1 input signal is OFF when the power supply is turned on again, the operation to the "Origin end" will be operated immediately, so please check the safety before proceeding.

## (2) Positioning operation by double solenoid mode

### - Procedure (Double solenoid mode) -

1. Specify and command operation using the operation data by turning IN0 and IN1 inputs ON.

⇒ Load the specified operation data

IN0 input: ON (IN1: OFF) → Command to move to the origin end
IN1 input: ON (IN0: OFF) → Command to move to the opposite end

↓

2. Start the positioning operation.

Turn IN0 and IN1 input OFF

↓

3. When reaching the target position, OUT0 output and OUT1 output turn ON corresponding to the operation data.

The positioning operation is completed.

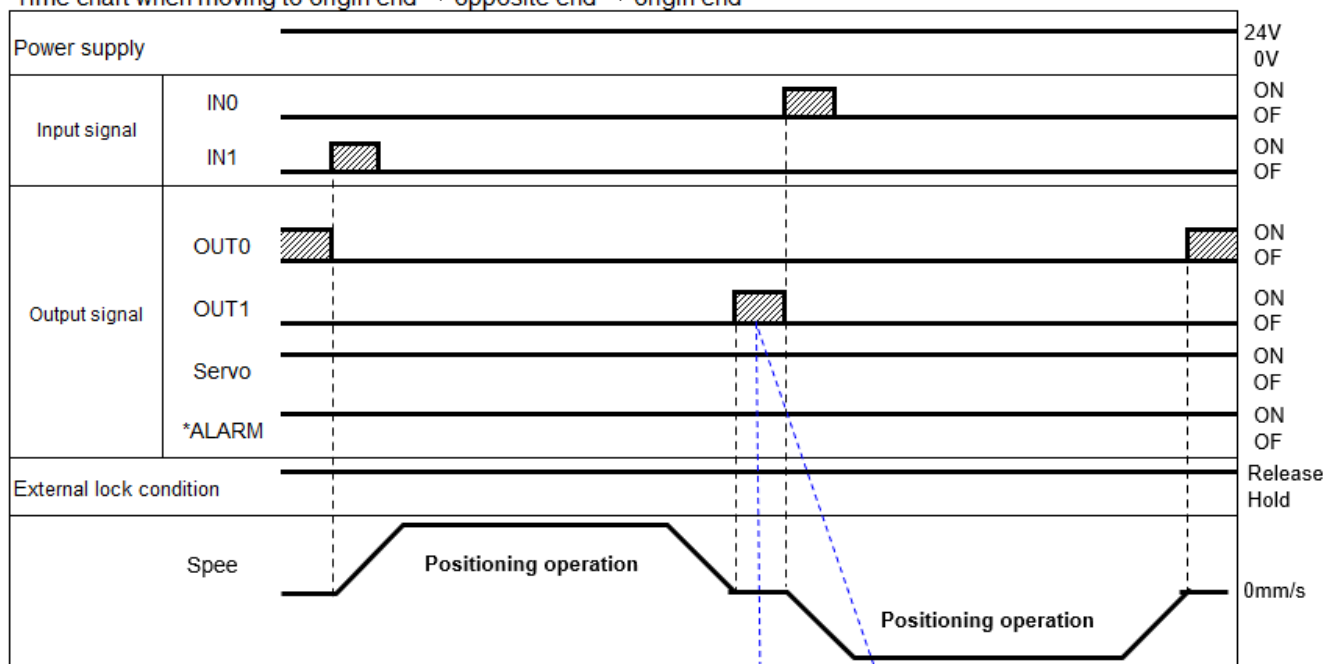
OUT0 output: ON → Completes the move to the origin end
OUT1 output: ON → Completes the move to the opposite end

\*In the double solenoid mode, simultaneous ON or simultaneous OFF of IN0 and IN1 is invalid.

Operation condition or the stopped condition continues accordingly.

### - Timing chart Positioning operation (Double solenoid mode) -

Time chart when moving to origin end → opposite end → origin end



\*The "\*"ALARM" is displayed in negative logic.

\*\*"Power ON" in the timing chart shows the power supply is turned ON.

\*\*"Servo ON" shows that power is supplied to the motor and it is operable.

### (3) Positioning operation by closed center mode

#### - Procedure (Closed center mode) -

1. Specify and command operation using the operation data by turning IN0 and IN1 inputs ON/OFF.  
 ⇒ Load the specified operation data.

( IN0 input: ON (IN1: OFF) → Command to move to the origin end  
 IN1 input: ON(IN0: OFF) → Command to move to the opposite end  
 IN0, IN1 input: ON → Command to move to the intermediate point )

2. Start the positioning operation.

3. When reaching the target position, the OUT0, OUT1, and OUT2 outputs corresponding to the operation data turn ON.

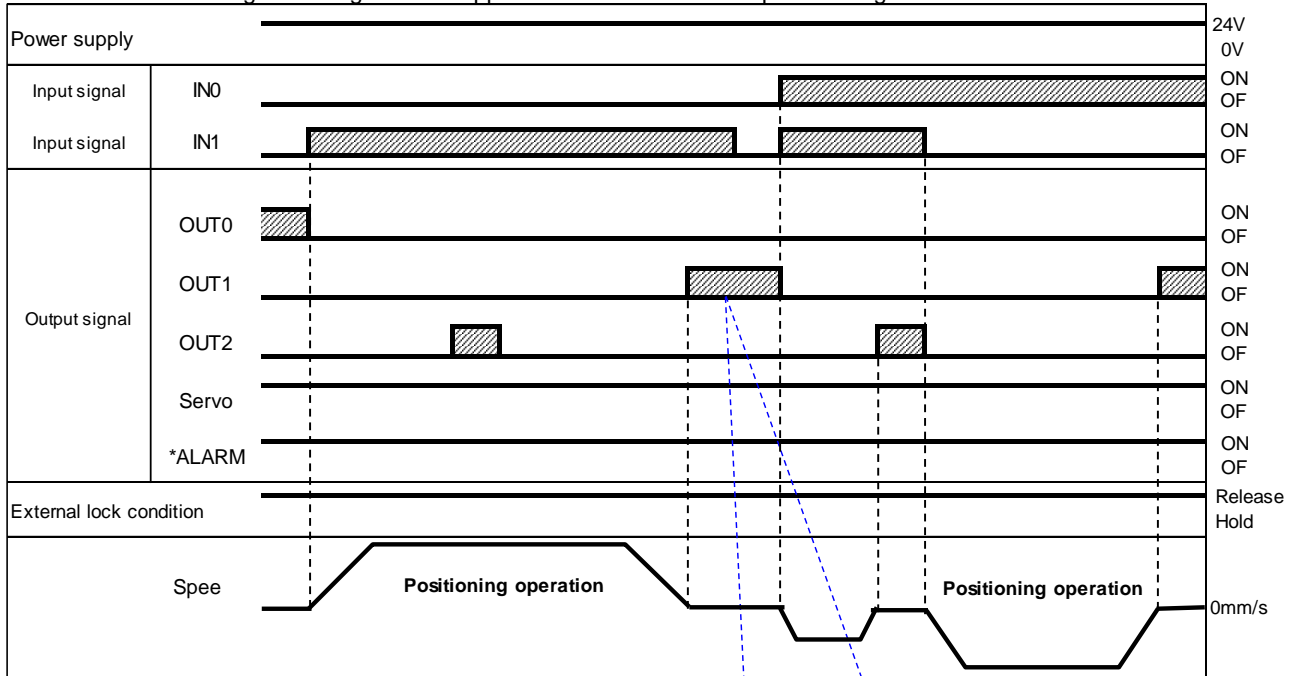
The positioning operation is completed.

( OUT0 output: ON → Completes the move to the origin end  
 OUT1 output: ON → Completes the move to the opposite end  
 OUT2 output: ON → Completes the move to the intermediate point )

\*When IN0 and IN1 are turned OFF simultaneously in the closed center mode, the deceleration and stop operation will be performed when in operation condition or the stopped condition will be maintained when stopped.

#### - Timing chart Positioning operation (Closed center mode) -

Time chart when moving to the origin end → opposite end → intermediate point → origin end



OUT output signal is ON when within ± "OUT signal output width" against the target position.

\*The "\*ALARM" is displayed in negative logic.  
 \*\*"Power ON" in the timing chart shows the power supply is turned ON.  
 \*\*"Servo ON" shows that power is supplied to the motor and it is operable.  
 \*The operation stops when the signal of IN0 or IN1 is turned OFF.

### 3.3.3 Reset

#### Alarm reset

**- Procedure -**

(1) Alarm is generated

(\*ALARM output turns OFF.)

↓

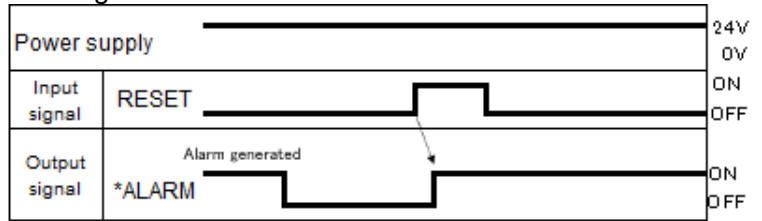
(2) Turn the RESET input ON.

↓

(3) The \*ALARM output turns ON when the generated alarm is of the alarm Groups B to D and the cause of the alarm is solved.

(Alarm will be reset.)

- Timing chart alarm reset-



\*\*\*ALARM\* is displayed in negative logic.

#### Warning

Thoroughly check safety before resetting the alarm since the operation described below will be performed according to the mode immediately after the alarm is reset by RESET.

• Single solenoid mode or closed center mode:

When the alarm is reset, the command from the upper-level device such as PLC will take effect, and the operation commanded by the upper-level device will be operated immediately.

• Double solenoid mode:

The operation commanded by the upper-level device such as PLC at the generation of the alarm will be performed immediately after the alarm is reset. (Even if both IN0 and IN1 commands are turned OFF at reset, the operation commanded at the generation of the alarm will be performed.)

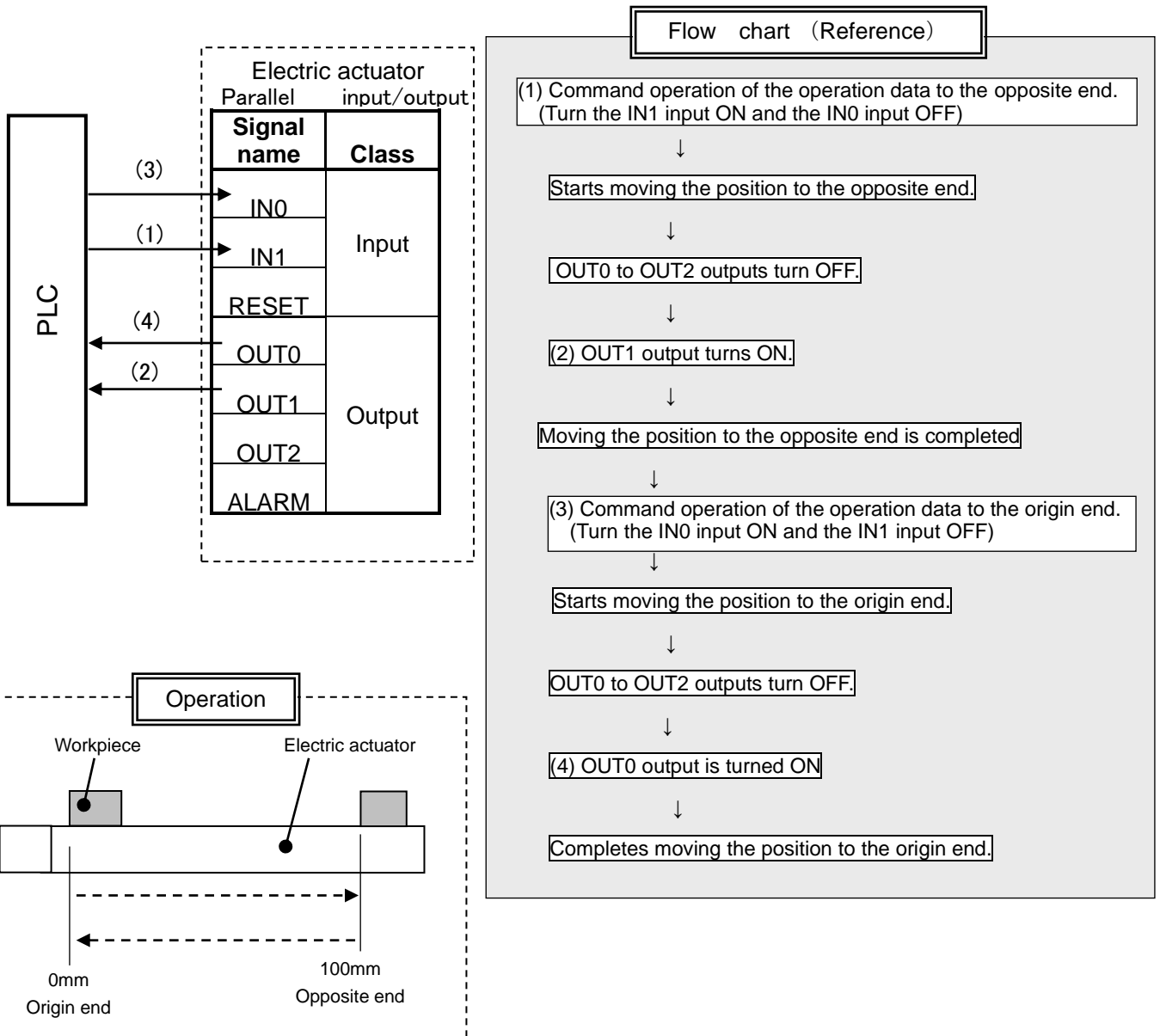
### 3.4 Operation Examples

#### 3.4.1 Positioning operation

Example) A setting example in the double solenoid mode is described when it is moved from the origin end (0 mm position) to the opposite end (100 mm position) with the speed of 100 mm/s (operation command to the opposite end) and then moved from the opposite end (100 mm position) to the origin end (0 mm position) with the speed of 300 mm/s (operation command to the intermediate point).

#### ■ Operation data setting example (Double solenoid mode)

No.	Position	mm	Speed m/s	Acceleration m/s <sup>2</sup>	Deceleration m/s <sup>2</sup>
1	Origin end	0.00	300	3000	3000
2	Opposite end	100.00	100	3000	3000

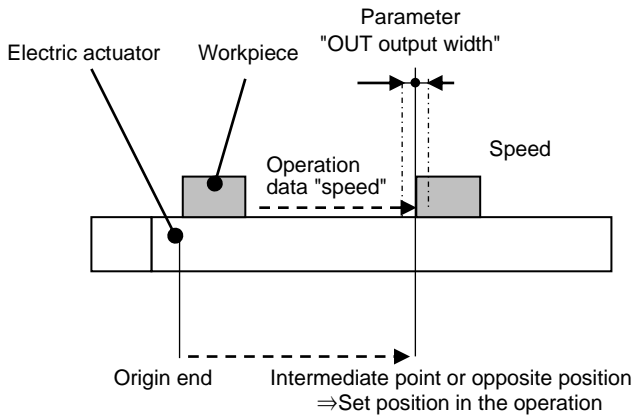


## 4 Operation Mechanism

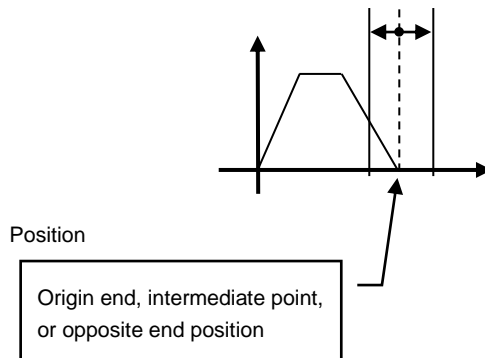
### 4.1 Positioning operation

When a check mark is entered with the setup software in the "Positioning operation" of the operation data, the positioning operation will be set and it will move to the position set as the "origin end, opposite end, and intermediate point" of the operation data by the "speed" and "acceleration/deceleration" set in the operation data.

#### • Positioning operation example



#### • Positioning operation (speed/position) example



## 4.2 Return to the origin

The operation to return to the origin is required in the events described below.

- (1) Motor is replaced
- (2) When the alarm "Group E" is generated and reset the alarm by turning on the power supply again.
- (3) The "return to the origin direction" parameter is changed

With this electric actuator, the "Absolute encoder ID mismatch error (153)" alarm will be generated when turning on the power supply after "(1) motor is replaced." In such a case, reset the alarm and perform the return to the origin operation.

The alarm is reset at the shipment from the factory with a brand-new electric actuator. Therefore, the "Absolute encoder ID mismatch error alarm (153)" will not be generated when turning on the power supply in (1).

### ● Return to the origin operation

For (1), (2), and (3) described above, the first operation command of IN0 and IN1 after turning on the power supply will be the operation to return to the origin.

When the operation to return to the origin is performed, the electric actuator moves in the return to the origin direction from the initial position when the power supply was turned on. ((1))

The slider moves to the end of the electric actuator and after a certain time it is stopped, the electric actuator will recognize the position as the end of the electric actuator.

Then, the electric actuator moves at a low speed in the direction opposite to the return to the origin direction. ((2))

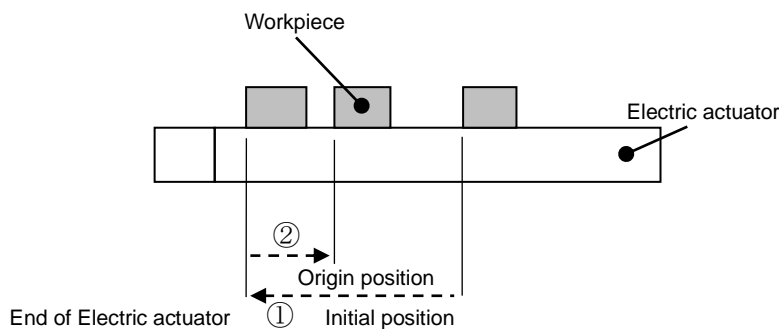
The position after the movement will be set as the origin position (0 mm position).

Return to the origin → Move to in the return to the origin direction

→ Movement stops when hits the end of the electric actuator

→ Reverse movement → Origin position (0 mm)

### ●Return to the origin operation example



### ⚠ Warning

The operation for the return to the origin is performed after resetting the Group E alarm and "Absolute encoder ID mismatch error" alarm or when the operation command is given as the first IN0, IN1 after changing the "return to the origin direction" parameter followed by the content of the operation command.

### ⚠ Caution

The return to the origin direction of the electric actuator differs according to the electric actuator and the "return to the origin direction" parameter.



### 4.3 Response time in receiving an electric actuator input signal

Factors of the response delay to the electric actuator input signal are described below.

- (1) Delay in electric actuator input signal scan
- (2) Delay in analysis and computing of the input signal
- (3) Delay in analysis and processing of the command

Make sure to have intervals of 15 ms or longer (30 ms is recommended) between input signals and maintain the state of the signal for the same period of time because delay in PLC processing and electric actuator scan can occur.

### 4.4 Methods of interrupting operation

There are two methods for interrupting the operation and stopping the electric actuator during the positioning operation and pushing operation as described below.

- Shutdown of M24V
- Limited to the closed center mode, turn both IN0 and IN1 input signals OFF

If the M24V is turned OFF during operation, the electric actuator decelerates and stops, and the servo will turn OFF, which does not hold the stopped position. (For an electric actuator with a lock, it is held by the lock function.)

#### **Warning**

When the electric actuator is stopped by shutting down M24V, thoroughly check safety before turning on the power supply to M24V again since the operation described below will be performed immediately after the power supply of M24V is turned on.

- Single solenoid mode or closed center mode:

When the power supply of M24V is turned on again, the command from the upper-level device such as PLC will take effect, and the operation commanded by the upper-level device when the power supply is turned on will be operated immediately.

- Double solenoid mode:

The operation commanded by the upper-level device such as PLC at the shutdown of M24V will be performed immediately after the power supply to M24V is turned on again. (Even if both IN0 and IN1 commands are turned OFF when the power supply to M24V is turned on again, the operation commanded at the shutdown of M24V will be performed.)

## 5 Alarm detection

The details of the alarm can be checked using the setting software.

Refer to the operation manual of the setup software for the alarm checking method.

When an alarm is generated, deactivate the alarm after troubleshooting and correcting the error with reference to [5.2 Alarm details](#).

### 5.1 Parallel signal output for the alarm group







The alarm types are categorized into four groups with this electric actuator in which the servo ON condition and the return to the origin completion condition according to the alarm group after an alarm is generated are shown in the table below.

Alarm group	Servo ON condition	Return to the origin completion condition	Operation restart procedure
Alarm group B	No change	No change	Input RESET
Alarm group C	No change	No change	Input RESET
Alarm group D	OFF	No change Note)	Input RESET Note)
Alarm group E	OFF	OFF	Power supply for control is turned off ⇒ Supply again

\*After the absolute encoder ID mismatch error (01-153) alarm is generated, the operation to return to the origin is required when restarting the operation

### 5.2 Alarm details

Controller setup software name (code)	Group	Alarm reset method	Conditions/Countermeasures
Set stroke is outside the stroke limit. (052)	B	Input RESET	<p>&lt;Condition&gt;</p> <p>(1) The current actuator position outside the stroke limit specified by the origin end and opposite end.</p> <p>(2) When the position at completion of return to origin is outside the setting range of the origin end and the opposite end.</p>
			<p>&lt;Countermeasure&gt;</p> <p>If this alarm occurs, please input the reset signal, and then instruct the operation again.</p>
Return to the origin was not completed within the set time (097)	C	Input RESET	<p>&lt;Condition&gt;</p> <p>Return to the origin is not completed within the set time.</p>
			<p>&lt;Countermeasure&gt;</p> <p>Check if the movement of the actuator was interrupted.</p>
Operation command was provided when the servo was turned OFF (098)	C	Input RESET	<p>&lt;Condition&gt;</p> <p>While the servo motor is turned off (24 VDC power supply not supplied to M24V), the positioning operation, pushing operation, or JOG operation command was provided.</p>
			<p>&lt;Countermeasure&gt;</p> <p>If an alarm is generated, command the operation after resetting the alarm and in servo ON condition (24 VDC power supply is turned on for M24V).</p>

Return to origin position is incomplete (099)	C	Input RESET	<p>&lt;Condition&gt;  - When changing the parameter "Rotating direction reference"  -When alarm group E has occurred.  In the above, the alarm occurs when JOG or Inching teaching is indicated from this setting software (e-Actuator setup tool) at the actuator power is switched on again.</p> <p>&lt;Countermeasure&gt;  If this alarm occurs, please input the reset signal first. Then do the JOG or Inching teaching after performing a drive test from this setting software (e-Actuator setup tool).  (When a drive test is indicated, "Return to Origin operation" is carried out first.)</p>		
The motor was rotated while the initial data of the encoder was communicating (101)	C	Input RESET	<p>&lt;Condition&gt;  Power supply was turned on when the actuator was operating with an external force.</p> <p>&lt;Countermeasure&gt;  Turn the RESET ON when the actuator is stopped.</p>		
Error occurred during communication with the encoder (106)	C	Input RESET	<p>&lt;Condition&gt;  This alarm occurs when an abnormality in communication with the encoder is detected when the power supply is turned on.</p> <p>&lt;Countermeasure&gt;  As it may be caused by noise, check the peripheral devices and remove devices that may be the source of the noise.</p>		
The motor speed has exceeded the set value (144)	D	Input RESET	<p>&lt;Condition&gt;  The motor speed exceeds the specified value due to external force and other factors.</p> <p>&lt;Countermeasure&gt;  Do not perform any operation that exceeds the maximum speed of the electric actuator.</p> <table border="1" data-bbox="598 1220 1516 1332"> <tr> <td style="text-align: center;"> <b>Caution</b></td> </tr> <tr> <td>Please refer to the operation manual or the catalog of the electric actuator for the maximum speed of the electric actuator.</td> </tr> </table>	 <b>Caution</b>	Please refer to the operation manual or the catalog of the electric actuator for the maximum speed of the electric actuator.
 <b>Caution</b>					
Please refer to the operation manual or the catalog of the electric actuator for the maximum speed of the electric actuator.					
Motor power supply voltage is outside the set range (145)	D	Input RESET	<p>&lt;Condition&gt;  The alarm may be generated by an increase in the regenerative power due to the electric actuator operation method.</p> <p>&lt;Countermeasure&gt;  Check if the operating condition of the electric actuator is within the specification range.</p> <table border="1" data-bbox="598 1568 1516 1691"> <tr> <td style="text-align: center;"> <b>Caution</b></td> </tr> <tr> <td>Please refer to the operation manual or the catalog of the electric actuator for the operation method of the electric actuator.</td> </tr> </table>	 <b>Caution</b>	Please refer to the operation manual or the catalog of the electric actuator for the operation method of the electric actuator.
 <b>Caution</b>					
Please refer to the operation manual or the catalog of the electric actuator for the operation method of the electric actuator.					
The internal temperature of the electric actuator is above the specified value (146)	D	Input RESET	<p>&lt;Condition&gt;  Ambient temperature of the power element in the electric actuator is too high.</p> <p>&lt;Countermeasure&gt;  Make improvements so that the temperature around the electric actuator is kept appropriate.</p>		

The control power supply voltage is outside the specification (147)	D	Input RESET	<b>&lt;Condition&gt;</b> The control power supply voltage is out of the specified range.
			<b>&lt;Countermeasure&gt;</b> Check the voltage supplied to the control power supply (C24V).
Large current was applied for a certain time (148)	D	Input RESET	<b>&lt;Condition&gt;</b> An overload condition continued for a certain time.
			<b>&lt;Countermeasure&gt;</b> Check that the movement of the electric actuator is not interrupted. In addition, confirm whether the electric actuator load, speed, and acceleration/deceleration are within the specification range of the electric actuator.
The target position was not reached within the specified time limit (149)	D	Input RESET	<b>&lt;Condition&gt;</b> Failed to reach the target position within the specified time limit.
			<b>&lt;Countermeasure&gt;</b> Check that the movement of the electric actuator is not interrupted. Confirm whether the electric actuator load, speed, and acceleration/deceleration are within the specification range of the electric actuator. When the "Positioning time level" parameter is set to a low value, reset the value to the default value.
communication error occurred (150)	D	Input RESET	<b>&lt;Condition&gt;</b> The cable is detached when operating the "Simple data setting screen" of the setup software (e-Actuator setup tool).
			<b>&lt;Countermeasure&gt;</b> Detach the setup communication cable after using the setup software (e-Actuator setup tool).
Encoder error (192)	E	Shut off the control power supply	<b>&lt;Condition&gt;</b> Abnormality in communication with the encoder.
			<b>&lt;Countermeasure&gt;</b> As it may be caused by noise, check the peripheral devices and remove devices that may be the source of the noise. Please contact SMC when it cannot be solved.
The output current is abnormally high (194)	E	Shut off the control power supply	<b>&lt;Condition&gt;</b> Output current is abnormally high.
			<b>&lt;Countermeasure&gt;</b> Please contact SMC when this alarm is generated.
Current sensor error (195)	E	Shut off the control power supply	<b>&lt;Condition&gt;</b> (1) Abnormality in the current sensor is detected when the power supply of M24V of the electric actuator is turned on. (2) When the power supply capacity is insufficient.
			<b>&lt;Countermeasure&gt;</b> (1) Check whether the electric actuator is operating by an external force when turning on the M24V power supply. When the electric actuator is installed vertically, check whether LK RLS is energized or not. If the alarm is still generated when the power is reapplied, please contact SMC. (2) Please check if the power supply capacity is insufficient or not.

(049) (051) (103) (109) (153) (193) (197) (198) (202)	-	-	<b>&lt;Condition&gt;</b> Please contact SMC when this alarm is generated.
			<b>&lt;Countermeasure&gt;</b> Please contact SMC when this alarm is generated.



## Warning

Thoroughly check safety before resetting the alarm since the operation described below will be performed according to the mode immediately after the alarm is reset by RESET.

- Single solenoid mode or closed center mode:

When the alarm is reset, the command from the upper-level device such as PLC will take effect, and the operation commanded by the upper-level device will be operated immediately.

- Double solenoid mode:

The operation commanded by the upper-level device such as PLC will be performed immediately after the alarm is reset. (Even if both IN0 and IN1 commands are turned OFF at reset, the operation commanded at the generation of the alarm will be performed.)

## 6 Troubleshooting

Refer to the table below for troubleshooting. When the causes in the troubleshooting table cannot be identified and normal operation can be recovered only by replacing the product, the product itself is probably out of order.

The product failure may be due to the operating conditions (application). Please contact SMC for assistance.

### Warning

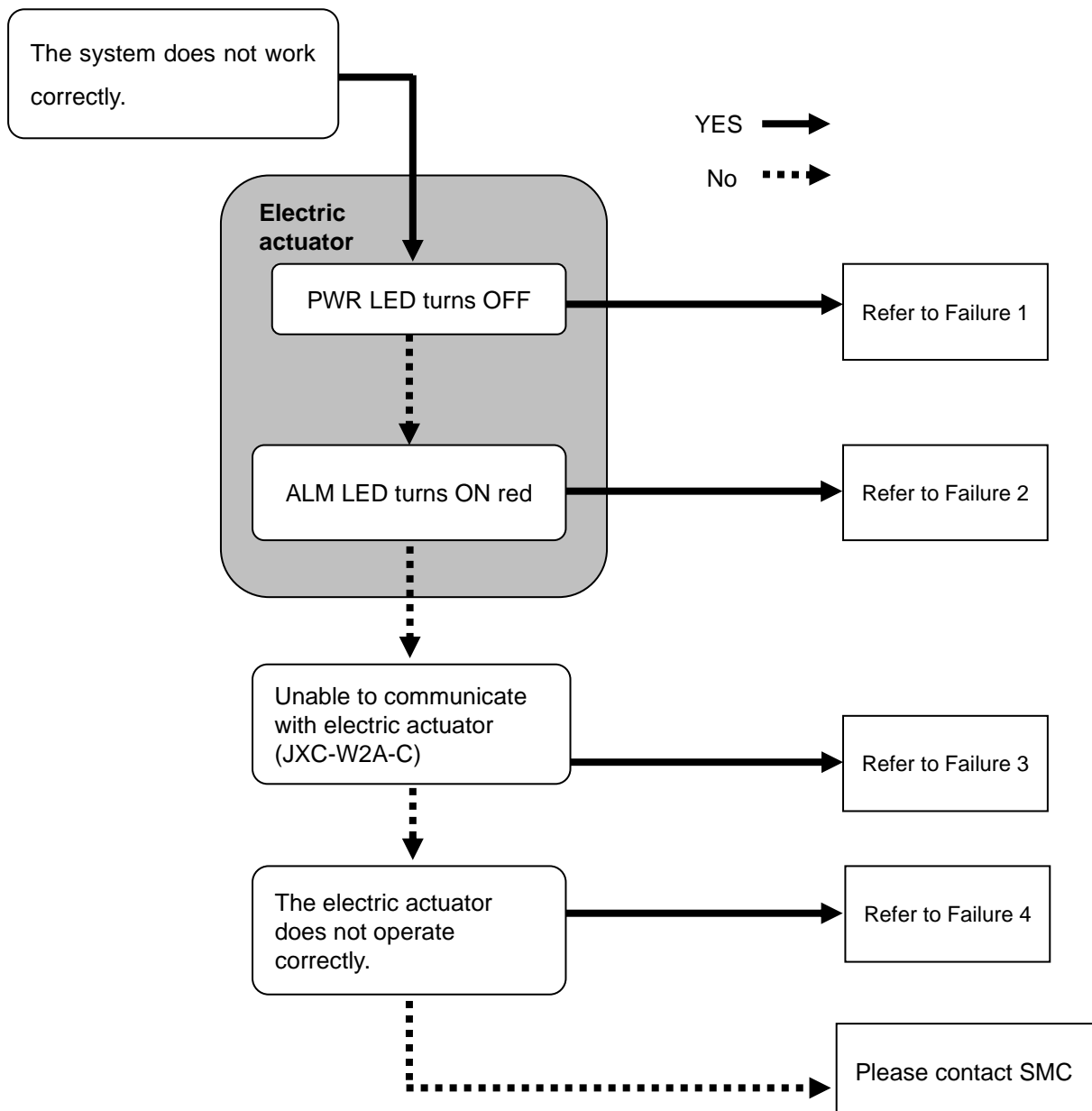
Thoroughly check safety before resetting the alarm since the operation described below will be performed according to the mode immediately after the alarm is reset by RESET.

- Single solenoid mode or closed center mode:

When the alarm is reset, the command from the upper-level device such as PLC will take effect, and the operation commanded by the upper-level device will be operated immediately.

- Double solenoid mode:

The operation commanded by the upper-level device such as PLC will be performed immediately after the alarm is reset. (Even if both IN0 and IN1 commands are turned OFF at reset, the operation commanded at the generation of the alarm will be performed.)



Problem No.	Problem	Problem Possible causes	Investigation method and possible causes	Countermeasures
1	LED is OFF.	Power fault	Is the green LED on the electric actuator ON?	Check the voltage and current supplied to the electric actuator. ⇒ <a href="#">2.5.1 Connection to input power supply</a>
		Incorrect wiring	Check that the wiring is correct.	Check if the wiring is connected correctly or if there is broken wire or short-circuit by referring to this Electric actuator Operation Manual. Correct the wiring and check that the input/output of each signal is correct. ⇒ <a href="#">2.5.1 Connection to input power supply</a> ⇒ <a href="#">2.5.3 Connection to PLCs, etc</a>
2	ALM: ON	Alarm generated	Check if the electric actuator is in the alarm condition.	Refer to the electric actuator operation manual, and take appropriate measures. Take appropriate measures based on the operation manual. ⇒ <a href="#">5 Alarm detection</a>
3	Communication fault (JX-CT-E)	The USB driver is not installed	Check that the USB driver for the communication cable is installed.	Please install the USB driver of USB cable. The USB driver's installation starts when the communication cable is connected with PC. Refer to the "Setup software (e-Actuator set up tool) installation procedure" for the installation
		Incorrect COM port setting	For details of the COM port checking and setting methods refer to the "Setting software" (e-Actuator Set up tool).	The COM port allocated to the communication cable is different for different PC's. Please confirm the COM port number with the communication cable connected. The COM port number can be checked using the Device Manager of the PC. Refer to the "Setup software (e-Actuator setup tool) installation procedure" for methods to confirm and set the COM port number.
		Connection failure	Check the wiring.	Please confirm Electric actuator = communications cable = USB cable = PC is connected. For example, communication cannot be established if the connector has been damaged. Please confirm the power supply of electric actuator has been turned ON. Communication cannot be established if the power supply is off. If equipment other than actuator (PLC and measurement equipment) relates to PC, remove these before checking. (There is a possibility that the communication with other equipment interferes in PC.)

4	Does not operate at all.	Lock release error	When the unlock switch is turned ON or OFF there is an unlocking sound made.	If there is no sound of lock release from the electric actuator with lock, the lock may be broken. If the problem persists, please contact SMC.
		External equipment failure	Check that the PLC connected to the electric actuator operates correctly.	Check the operation by test run using the "Setting software" (e-Actuator Set up tool). If the actuator is operated, a signal output from the PLC is suspected. Refer to the electric actuator operation manual and take appropriate measures. ⇒ <a href="#">7.4.1 Details of parallel input/output signals</a>
		Influence of a magnetic force	Check if there is equipment which generates the magnetic force, such as a magnet or electro-magnetic coil around the actuator.	The equipment, which generates the magnetic force, should be kept away from the motor. For example, keep 40 mm minimum distance from the cylinder with auto switch.
		Stop command	If it is not energized, the servo will be OFF and does not operate. Check if a voltage of 24 VDC is applied to the EMG terminal.	Apply 24VDC to the M24V terminal.
	Operati on stops intermittently	Incorrect wiring	Check that the wiring is correct.	Check if the wiring is connected correctly or if there is broken wire or short-circuit by referring to this electric actuator Operation Manual. Correct the wiring and check that the input/output of each signal is correct. Separate the power supply for the actuator input and the parallel I/O signal power supply. ⇒ <a href="#">2.5.1 Connection to input power supply</a> ⇒ <a href="#">2.5.3 Connection to PLCs, etc</a>
		Electric noise	Check that the grounding is connected correctly. Are power cables for other equipment and electric actuator cables bundled together?	Connect to Ground correctly. Avoid bundling the cables with power cables of other equipment. Are power cables for other equipment and electric actuator cables bundled together? ⇒ <a href="#">2.4 Installation of electric actuators</a>
		Incorrect parameters	Check that the parameter values are correct.	Modify the parameters accordingly and check the operation. ⇒ <a href="#">2.7 Setup of the operation parameters</a> ⇒ <a href="#">8 Setting</a>
		Voltage drop	Check if there are any temporary voltage drops in the power supply. (When a temporary voltage drop occurs, the M24V terminal of the power supply connector will turn OFF and the electric actuator will stop. However, this stop will be released when the voltage recovers.)	There is a possibility of a momentary voltage drop because the capacity of the power supply is insufficient, or if the power supply is "inrush-current control" type. ⇒ <a href="#">7 Specifications</a>
		Influence of magnetic force	Check if there is equipment which generates the magnetic force, such as a magnet or electro-magnetic coil around the actuator.	The equipment, which generates the magnetic force, should be kept away from the motor. For example, keep 40 mm minimum distance from the cylinder with auto switch.



	Signal timing	Check the timing of the signal from the PLC to the electric actuator.	Make sure to have intervals of 15 ms or longer (30 ms is recommended) between input signals and maintain the state of the signal for the same period because delay in PLC processing and electric actuator control part scan can occur. ⇒ <a href="#">4. 3 Response time in receiving an electric actuator input signal</a>
	Alarm generated	Is electric actuator alarm generated?	Refer to the electric actuator operation manual, and take appropriate measures. Take appropriate measures based on the operation manual. ⇒ <a href="#">5 Alarm detection</a>
The actuator does not move to the correct position.	Incorrect Origin position	If it is a pushing operation, repeat return to origin operations several times to check if the electric actuator returns to the origin correctly.	Perform the return to origin position operation several times to check the origin position. Take measures to make the electric actuator operate normally (remove foreign matter that interferes with the actuator movement, etc.)
	Incorrect parameters	Check that the parameter values are appropriate and the program is correct.	Check the maximum speed, maximum acceleration speed, and maximum deceleration speed of the electric actuator again, and then be sure to enter the correct parameters to check for correct operation. ⇒ <a href="#">2. 7 Setup of the operation parameters</a> ⇒ <a href="#">8 Setting</a>
Does not move to the correct position.	Incorrect wiring	Check that the wiring is correct.	Check again if the wiring is connected correctly or if there is any broken wire or short-circuit by referring to the operation manual of this electric actuator. Correct the wiring if there is any incorrect wiring and check that the input/output of each signal is correct. In addition, 0 V (GND) of both the electric actuator input power supply and the parallel input/output signal power supply shall be the same. ⇒ <a href="#">2. 5. 1 Connection to input power supply</a> ⇒ <a href="#">2. 5. 3 Connection to PLCs, etc</a>
	Influence of a magnetic force	Check if there is equipment which generates the magnetic force, such as a magnet or electro-magnetic coil around the actuator.	The equipment, which generates the magnetic force, should be kept away from the motor. For example, keep 40 mm minimum distance from the cylinder with auto switch.
	Signal timing	Check that the PLC connected to the electric actuator operates correctly.	Make sure to have intervals of 15 ms or longer (30 ms is recommended) between input signals and maintain the state of the signal for the same period because delay in PLC processing and electric actuator control part scan can occur. ⇒ <a href="#">4. 3 Response time in receiving an electric actuator input signal</a>
	Data not stored correctly	Is the data (step data or parameters) written correctly?	One of the following actions occurred during data writing (while the power supply LED (green) was on). • Turn off the electric actuator input power supply. - Disconnected/ connected the cables. Input correct data (step data, parameter) again and confirm operation. ⇒ <a href="#">7 Specifications</a> ⇒ <a href="#">2. 7 Setup of the operation parameters</a> ⇒ <a href="#">8 Setting</a>

Speed not achieve	Incorrect parameters	Check that the parameter values are correct.	Check the max. speed and acceleration speed of the electric actuator and be sure to input the correct parameters. ⇒ <a href="#">2.7 Setup of the operation parameters</a> ⇒ <a href="#">8 Setting</a>
	Operation pattern is not suitable.	Check if a trapezoidal acceleration/deceleration is programmed for the actuator operation.	In case of such operation, the actuator may start slowing down before it reaches the maximum speed. Modify the setting to make the moving distance longer or the acceleration larger. ⇒ <a href="#">エラー! 参照元が見つかりません。</a> ⇒ <a href="#">8 エラー! 参照元が見つかりません。</a>
	Influence of a magnetic force	Check if there is equipment which generates the magnetic force, such as a magnet or electro-magnetic coil around the actuator.	The equipment, which generates the magnetic force, should be kept away from the motor. For example, keep 40 mm minimum distance from the cylinder with auto switch.
	Voltage drop	Check if there are any temporary voltage drops in the power supply. (When a temporary voltage drop occurs, the M24V terminal of the power supply connector will be in low voltage and the electric actuator will stop. However, this stop will be released when the voltage recovers.)	There is a possibility of a momentary voltage drop because the capacity of the power supply is insufficient, or if the power supply is "inrush-current control" type. ⇒ <a href="#">7 Specifications</a>

### **Warning**

Thoroughly check safety before resetting the alarm since the operation described below will be performed according to the mode immediately after the alarm is reset by RESET.

- Single solenoid mode or closed center mode:

When the alarm is reset, the command from the upper-level device such as PLC will take effect, and the operation commanded by the upper-level device will be operated immediately.

- Double solenoid mode:

The operation commanded by the upper-level device such as PLC will be performed immediately after the alarm is reset. (Even if both IN0 and IN1 commands are turned OFF at reset, the operation commanded at the generation of the alarm will be performed.)

## 7 Specifications

### 7.1 Basic specifications of the product

Basic specifications of the product are shown below.

Basic specifications of the product are shown below.

Item	Specification
Controlled motor	Step motor (servo 24 VDC )
Power supply <sup>Note1)2)</sup>	Power supply voltage : 24VDC±10% 【for both of motor drive power control power, stop, lock brake release】
Parallel input	3 inputs
Parallel output	4 outputs (maximum 40 mA or less)
Compatible encoder	Battery-less absolute encoder (resolution: 4096 pulses/rotation)
Serial communication	Serial communication RS485 (For JX-CT□-E)
LED display	LED (Green/Orange/Red) 1 for each
Lock control	Unlocking terminal (applicable to non-excitation magnetizing lock)
Cable length	I/O cable: 10 m or shorter Power supply cable : 10m or less
Cooling method	Natural air cooling
Operating temperature range	0°C to 40°C (No freezing) <sup>Note 3)</sup>
Operating humidity range	90%RH or less (No condensation)
Storage temperature range	-10~60°C (No freezing)
Storage humidity range	90%RH or less (No condensation)
Insulation resistance	Between the external terminals and case 50 MΩ (500 VDC)

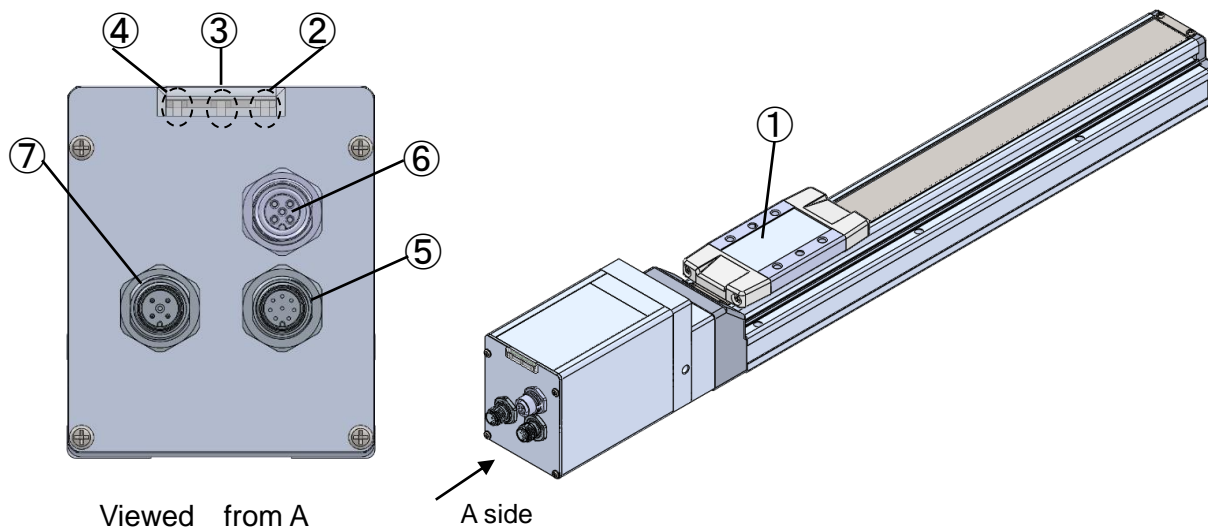
Note 1 ) Power supply do not use the power supply of “inrush current restraining type”.

Note 2 ) The power consumption changes depending on the electric actuator model.

Refer to the specifications of the electric actuator for more details.

## 7.2 Parts Description

Details of the parts of the electric actuator.



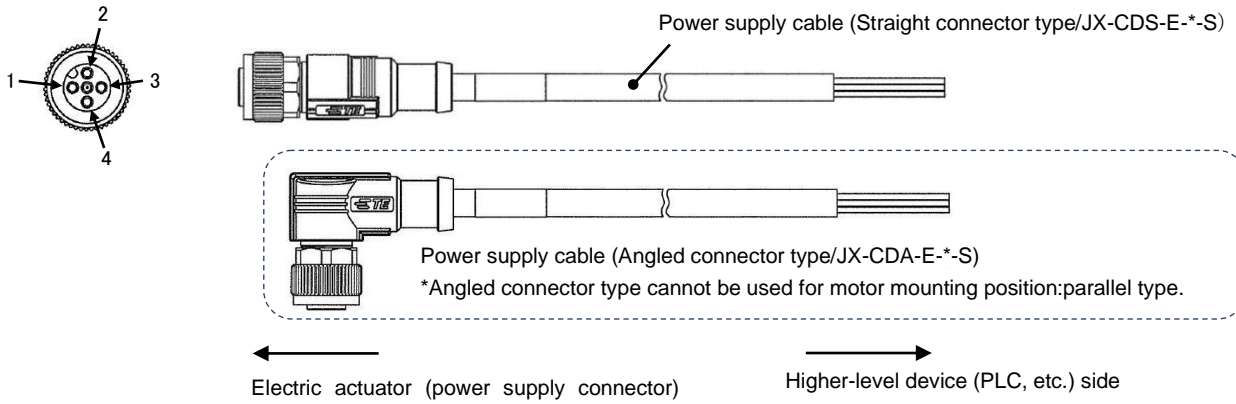
No.	Item	Details
①	Piston rod	Drive terminal Loads and transfers workpieces, etc.
②	Power supply LED (Green)	Power supply ON/No alarm: Green LED is ON Power supply OFF (M24V: OFF, C24V: OFF or ON): Turned off
③	Alarm LED (Red)	Alarm is generated: Red LED is ON
④	Over load Warning LED (Orange)	Over load Warning is generated : Orange LED is ON Indicated operation may be overloaded. Please modify the operation details.
⑤	Parallel I/O Connector (8 pins)	Connect to PLC using I/O cable. (3 inputs、 4 inputs)
⑥	Connector (5 pins) for setting	Connects to the PC.
⑦	Power supply connector (4 pins)	Connect to actuator input power supply (24 VDC) using power supply cable. Control power (+)、 Motor power (+)、 Lock release (+)、 Common power (-)

### 7.3 Power supply connector Specification

Connect the power supply cable (JX-CD\*-E-\*-S) to the power supply connector.

Tighten the socket with 0.6 N·m when connecting the power supply cable to the power supply connector.

Specifications of the power supply cable are described below.



<b>Each wire conductor size</b>	AWG22
<b>Number of core wires</b>	4
<b>Connector specification</b>	M12, 4-pin socket, A code (Normal key)

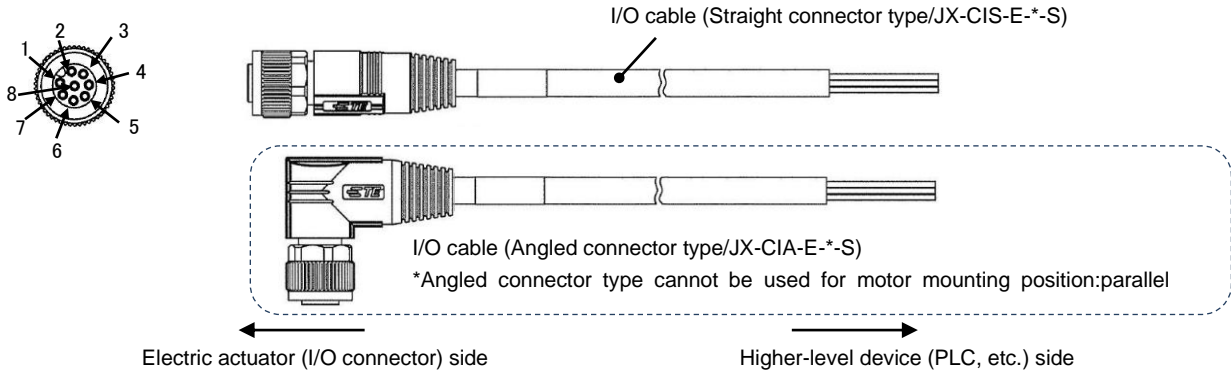
Pin No.	Wire color	Terminal name	Function name	Functional explanation
1	Brown	C24V	Control power supply (+)	The control power supply (+) side supplied to the electric actuator.
2	White	M24V	Motor power supply (+)	The motor power supply (+) side supplied to the electric actuator.
3	Blue	0V	Common power supply (-)	Common among M24V terminal/C24V terminal//LK RLS terminal (-).
4	Black	LK RLS	Lock release (+)	Lock release (+) input.

## 7.4 I/O connector specification

Connect the I/O cable (JX-CI\*-E-\*-S) to the parallel I/O connector.

Tighten the socket with 0.6 N·m when connecting the I/O cable to the parallel I/O connector.

Specifications of the I/O cable are described below.



<b>Each wire conductor size</b>	AWG24
<b>Number of core wires</b>	8
<b>Connector specification</b>	M12, 8-pin socket, A code (Normal key)

### 7.4.1 Details of parallel input/output signals

- Input side -

\*When green is the I/O cable (JX-CI\*-E-\*-S)

Terminal No.	Wire color	Signal name	Description																																		
1	White	INO	The operation data to operate is specified by the combination of ON/OFF of IN0 and IN1 inputs. The combination of IN0 and IN1 inputs for the operation data to command is shown in the table below.																																		
2	Brown	IN1	<table border="1" style="width: 100%;"> <thead> <tr> <th colspan="2" rowspan="2">Input</th> <th colspan="2">Double solenoid mode/closed center mode</th> <th colspan="2">Single solenoid mode</th> </tr> <tr> <th>IN1</th> <th>IN0</th> <th>IN1</th> <th>IN0</th> </tr> </thead> <tbody> <tr> <td colspan="2">Command operation data</td> <td></td> <td></td> <td></td> <td></td> </tr> <tr> <td colspan="2">Origin end</td> <td>○</td> <td>●</td> <td>○</td> <td>○</td> </tr> <tr> <td colspan="2">Opposite end</td> <td>●</td> <td>○</td> <td>○</td> <td>○</td> </tr> <tr> <td colspan="2">Intermediate point *Only for the closed center mode</td> <td>●</td> <td>●</td> <td></td> <td></td> </tr> </tbody> </table> <p>○: OFF ●: ON</p>	Input		Double solenoid mode/closed center mode		Single solenoid mode		IN1	IN0	IN1	IN0	Command operation data						Origin end		○	●	○	○	Opposite end		●	○	○	○	Intermediate point *Only for the closed center mode		●	●		
Input		Double solenoid mode/closed center mode				Single solenoid mode																															
		IN1	IN0	IN1	IN0																																
Command operation data																																					
Origin end		○	●	○	○																																
Opposite end		●	○	○	○																																
Intermediate point *Only for the closed center mode		●	●																																		
3	Green	RESET	Resets the alarm.																																		

#### Warning

Thoroughly check safety before resetting the alarm since the operation described below will be performed according to the mode immediately after the alarm is reset by RESET.

- Single solenoid mode or closed center mode:

When the alarm is reset, the command from the upper-level device such as PLC will take effect, and the operation commanded by the upper-level device will be operated immediately.

- Double solenoid mode:

The operation commanded by the upper-level device such as PLC will be performed immediately after the alarm is reset. (Even if both IN0 and IN1 commands are turned OFF at reset, the operation commanded at the generation of the alarm will be performed.)

#### Caution

Make sure to have intervals of 15 ms or longer (30 ms is recommended) between input signals and maintain the state of the signal for the same period of time.

- Output side -

\*When green is the I/O cable (JX-CI\*-E-\*-S)

Terminal No.	Wire color	Signal name	Description																
5	Gray	OUT0	The condition where the OUT0, OUT1, and OUT2 outputs turn ON differs when the commanded operation data are for the positioning operation or the pushing operation.  [For positioning operation] Turns ON when the current position is within the "Position" +/- "OUT output width" of the operation data.																
6	Pink	OUT1	[For pushing operation] Turns ON when the pushing force is equal to the "pushing force" of the operation data.  The OUT0, OUT1, and OUT2 outputs that turn ON by the commanded operation data are shown in the table below.																
7	Blue	OUT2	<p style="text-align: right;">○: OFF ●: ON</p> <table border="1" style="margin-left: auto; margin-right: auto;"> <thead> <tr> <th style="text-align: center;">Command operation data \ Output</th> <th style="text-align: center;">OUT0</th> <th style="text-align: center;">OUT1</th> <th style="text-align: center;">OUT2</th> </tr> </thead> <tbody> <tr> <td style="text-align: center;">Origin end</td> <td style="text-align: center;">●</td> <td style="text-align: center;">○</td> <td style="text-align: center;">○</td> </tr> <tr> <td style="text-align: center;">Opposite end</td> <td style="text-align: center;">○</td> <td style="text-align: center;">●</td> <td style="text-align: center;">○</td> </tr> <tr> <td style="text-align: center;">Intermediate point</td> <td style="text-align: center;">○</td> <td style="text-align: center;">○</td> <td style="text-align: center;">●</td> </tr> </tbody> </table>	Command operation data \ Output	OUT0	OUT1	OUT2	Origin end	●	○	○	Opposite end	○	●	○	Intermediate point	○	○	●
Command operation data \ Output	OUT0	OUT1	OUT2																
Origin end	●	○	○																
Opposite end	○	●	○																
Intermediate point	○	○	●																
8	Red	*ALARM <small>Note 1)</small>	Turned ON when there are no alarms. Turns OFF when an alarm is generated.																

Note 1) \*ALARM is output in negative logic.

Changes in the output signal with respect to the state of the electric actuator are shown in the table below.

Condition signal	Output	OUT*	Servo ON	Lock
Servo ON in the stopped condition after the power supply is turned ON		ON <sup>Note 2)</sup>	ON	Release
During movement by positioning/pushing operation		OFF	ON	Release
On completion of the positioning operation (when within the OUT output width)		ON <sup>Note 2)</sup>	ON	Release
Stopped due to pushing a workpiece in pushing operation (maintaining)		ON	ON	Release
Idled and stopped due to no detection of a workpiece during a pushing operation		OFF	ON	Release
Stopped due to shutdown of M24V		OFF <sup>Note 2)</sup>	OFF	Lock

Note 2) ON when it is within the "OUT output width" of the origin end position, opposite end position, and intermediate point position.

## 7.4.2 Parallel input/output specification

### • Input specification

Items	Specification
Input circuit insulation method	Non-insulated
Number of inputs	3 points
Input voltage	24 VDC +/- 10 (%)
Input current when ON	5mA
ON/OFF voltage	ON voltage 21.6 VDC or more OFF voltage 4 VDC or less
Current leakage	1 mA or less

### • Output specification

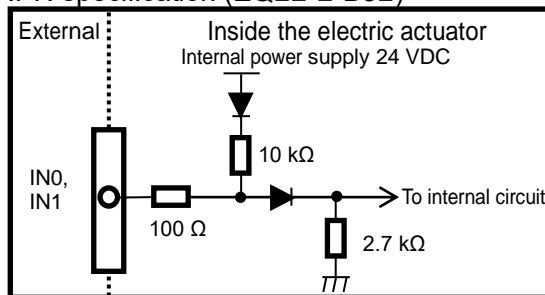
Items	Specification
Output circuit insulation method	Non-insulated
Number of outputs	4 points
Load voltage	24 VDC +/- 10 (%)
Maximum load current	40mA
Residual voltage	2 VDC or less
Current leakage	0.1 mA or less

## 7.4.3 Parallel input/output type circuit (NPN and PNP specifications)

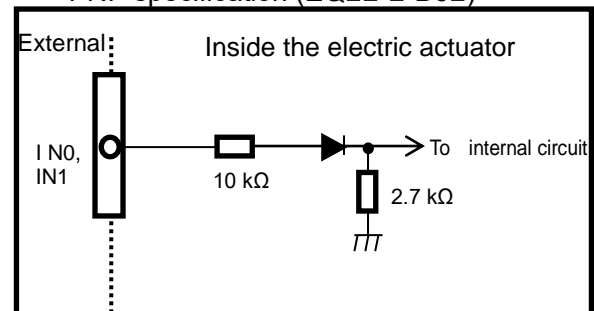
NPN specification and PNP specification are available (parallel I/O type is different between NPN type and PNP type) for this electric actuator.

### ■ Parallel I/O input circuit

#### • NPN specification (EQ□□-□-B5□)

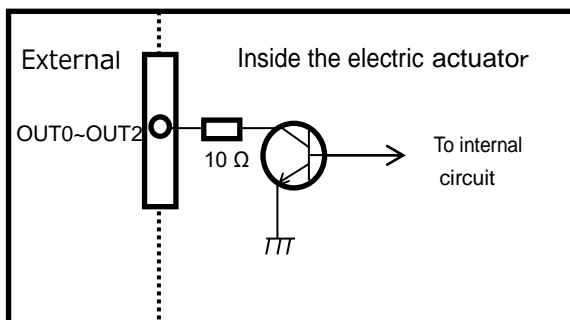


#### • PNP specification (EQ□□-□-B6□)

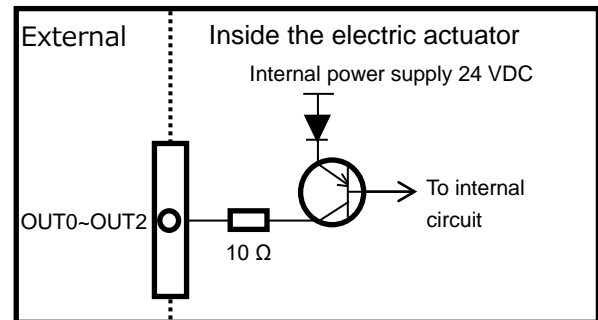


### ■ Parallel I/O output circuit

#### • NPN specification (EQ□□-□-B5□)



#### • PNP specification (EQ□□-□-B6□)



## ⚠ Caution

The parallel input/output of this electric actuator is of non-insulated specification.

Use the electric actuator input power supply 24 VDC for the power supply of both parallel input and output.

(Use the same input power supply as the control power supply C24V for the parallel input/output power supply.)



## 8 Setting

### 8.1 Operation data

Operation data is the setting for operating the electric actuator.

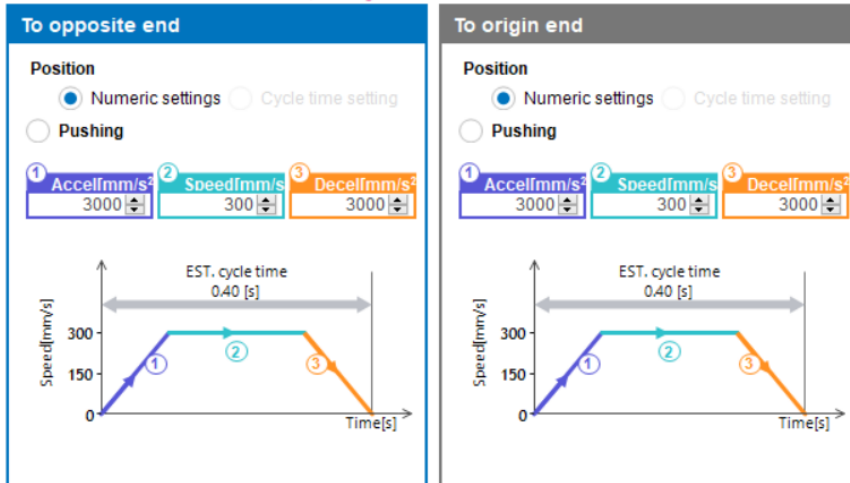
The example shown below is the operation data setting example for the single solenoid mode and double solenoid mode using the e-Actuator setup tool/setup software.

In the closed center mode, the operation data setting screen for the intermediate point is added in the operation condition.

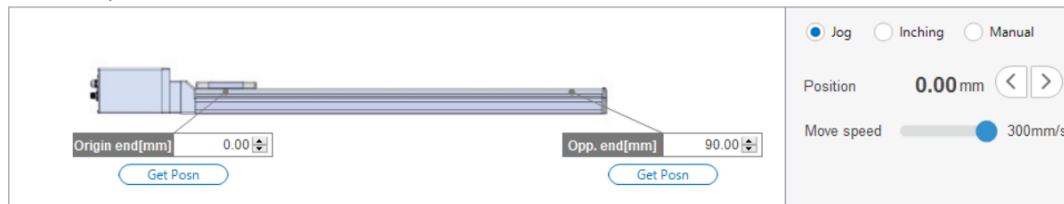
The operation data set in this phase will become effective immediately after it is written in the electric actuator.

Example) Operation data setting of the e-Actuator setup tool/setup software (for single/double solenoid mode)

Operation condition \* In this chart, settling time is not included.



Position setup



### ! Caution

Write the operation data when the electric actuator is stopped.

### Details of operation data

Name	Input range	Description
Speed	Minimum value to maximum speed Note 1)	Sets the speed for moving to the target position. (Unit: mm/s)
Acceleration	1 to maximum acceleration Note 1)	Sets the acceleration to reach the moving speed. (Unit: mm/s <sup>2</sup> )
Deceleration	1 to maximum acceleration Note 1)	Sets the deceleration to reach the moving speed. (Unit: mm/s <sup>2</sup> )
Origin end	0 to product stroke	Target position of the origin end of the actuator. Or the stop position in pushing operation. (Unit: mm)
Opposite end	0 to product stroke	Target position of the opposite end of the actuator. Or the stop position in pushing operation. (Unit: mm)
Intermediate point	0 to product stroke	Target position of the Intermediate point of the actuator. (Unit: mm)

Note 1) Please refer to the specification table on page 26.

## 8.2 Parameter

Setting of operation condition and other conditions of the electric actuator.

### Caution

Write the parameter when the electric actuator is stopped.

### Details of parameters

The parameters can be set using the setup software e-Actuator SETUP tool.

Write column: ☉ = Effective immediately after writing in the electric actuator, ○ = Effective when the power supply is turned on again

Setting	Lead	Default value			Description	Input range	Load
		EQFS25	EQFS32	EQFS40			
Speed	H	Max. speed of each product			Sets the speed for moving to the target position or to the start position for the pushing operation. (Unit: mm/s)	Input limit value to speed of each product	☉
	A						
	B						
	C						
Acceleration	-	5000	5000	5000	Sets the acceleration to reach the moving speed. (Unit: mm/s <sup>2</sup> )	to 10000	☉
Deceleration	-	5000	5000	5000	Sets the deceleration to reach the moving speed. (Unit: mm/s <sup>2</sup> )	to 10000	☉
Origin end position	-	0			Sets the target position. (Unit: mm)	0 to Product stroke	☉
Opposite end position	-	Product stroke			Sets the target position. (Unit: mm)	0 to Product stroke	☉
Intermediate point position	-	Stroke 50 mm or less: 27	27	70	Sets the target position. (Unit: mm)	0 to Product stroke	☉
		Stroke 50 mm or more: 42					
OUT signal output width	-	0.5	0.5	0.5	Sets the width to turn the OUT signal ON during the positioning operation. The OUT signal turns ON in the target position ± setting value. (Unit: mm)	0.01 to Product stroke	☉
Rotating direction reference *1	-	In-line:1 Parallel:2	In-line:1 Parallel:2	In-line:1 Parallel:2	Change the coordinate of the electric actuator. The direction will be opposite from the return to the origin when the setting is changed. Therefore, the return to the origin is required.*1	1: Normal direction 2: Reverse direction	○
Acceleration and deceleration ratio	-	10	10	10	Sets the level of followability of acceleration/deceleration. Followability to the acceleration becomes loose as the setting value increases. (Becomes close to the trapezoidal acceleration as the setting value reaches 0)	10 to 100	☉
Torque when held *2	-	50	70	70	Sets the torque when stopped after the positioning operation. (Unit: %)	EQFS25 : 1 to 50 EQFS32 : 1 to 70 EQFS40 : 1 to 70	☉
Position loop P constant	H	140	80	80	Sets the position loop P constant. *Please perform the actuator operation after changing this parameter setting under the responsibility of the user.	1 to 200	☉
	A	140	110	110			
	B	100	80	80			
	C	110	80	80			
Speed loop P constant	H	80	140	140	Sets the speed loop P constant. *Please perform the actuator operation after changing this parameter setting under the responsibility of the user.	1 to 200	☉
	A	110	140	140			
	B	120	75	100			
	C	150	120	120			
Speed loop I constant	H	50	80	80	Sets the speed loop I constant. *Please perform the actuator operation after changing this parameter setting under the responsibility of the user.	10 to 200	☉
	A	110	50	50			
	B	90	60	60			
	C	100	60	60			
Positioning time level	-	2	2	2	Sets the time to generate the positioning time error alarm. (Unit: s)	0.1 to 25.5	☉

\*1 After changing the rotation direction reference and turning on the power again, return to origin is executed with the first movement command. If movement is obstructed during this return to origin, normal return to origin will not be possible. Therefore, make sure that there are no obstacles or loads within the movable range before returning to the origin so that the actuator can perform full stroke operation.

 **Caution**

- The direction in which the electric actuator returns to its origin depends on the electric actuator and the "rotation direction reference" parameter.
- If movement is obstructed during return to origin, normal return to origin will not be possible. Therefore, make sure that there are no obstacles or loads within the movable range before returning to origin so that the actuator can perform full stroke operation.

\*2 For vertical use, do not change the torque when held from the Default value.  
For horizontal use, it is possible to lower the torque when held from the Default value, but after changing the torque when held, check if there is any problem with the behavior when the actuator stops.

## 9 Optional parts (sold separately)

Optional parts described below are available (sold separately).

- Power supply cable
- I/O cable
- Setup communication cable
- e-Actuator setup tool/setup software (download from SMC webpage)

### 9.1 Power supply cable

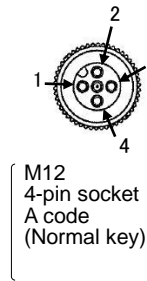
#### JX-CD□-E-□-S

● Cable length (L[m])

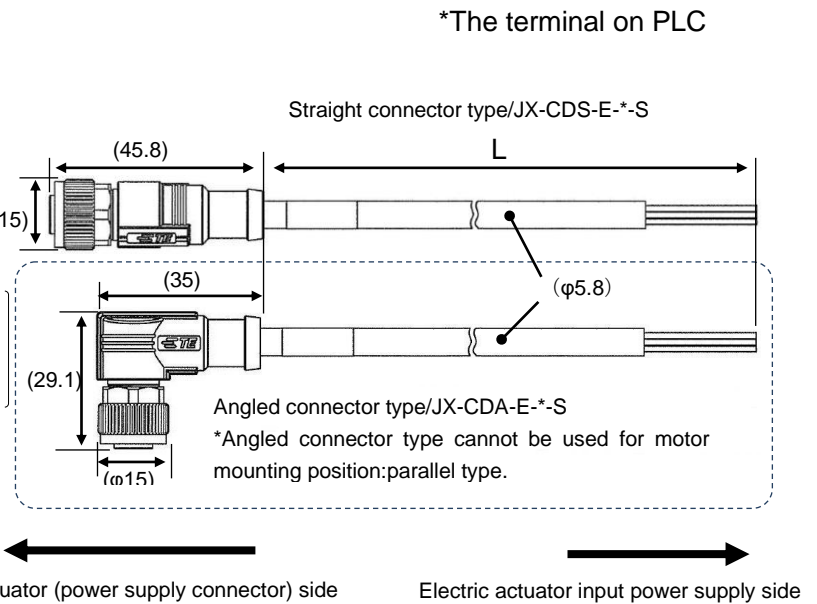
1	1.5
3	3
5	5
10	10

● Connector type

S	Straight
A	Angle



M12  
4-pin socket  
A code  
(Normal key)



### 9.2 I/O cable

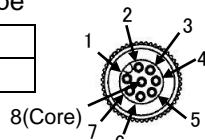
#### JX-CI□-E-□-S

● Cable length (L[m])

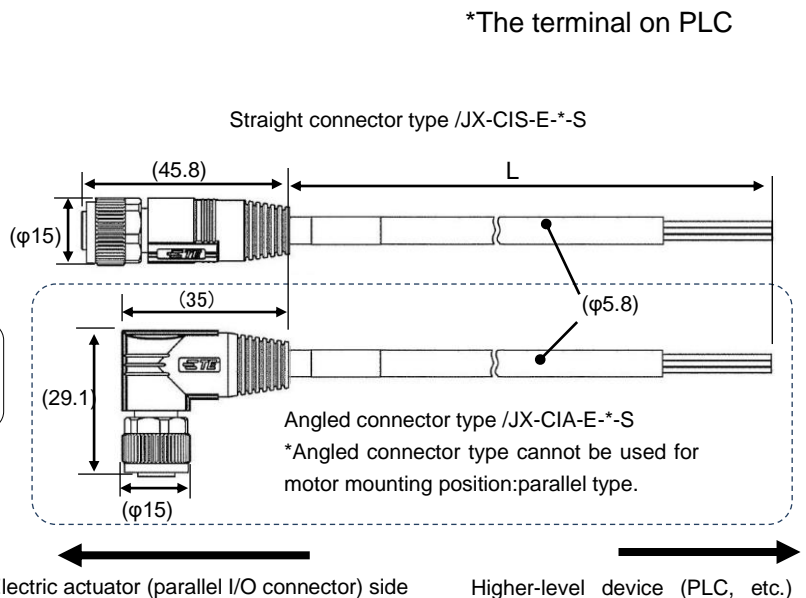
1	1.5
3	3
5	5
10	10

● Connector type

S	Straight
A	Angle



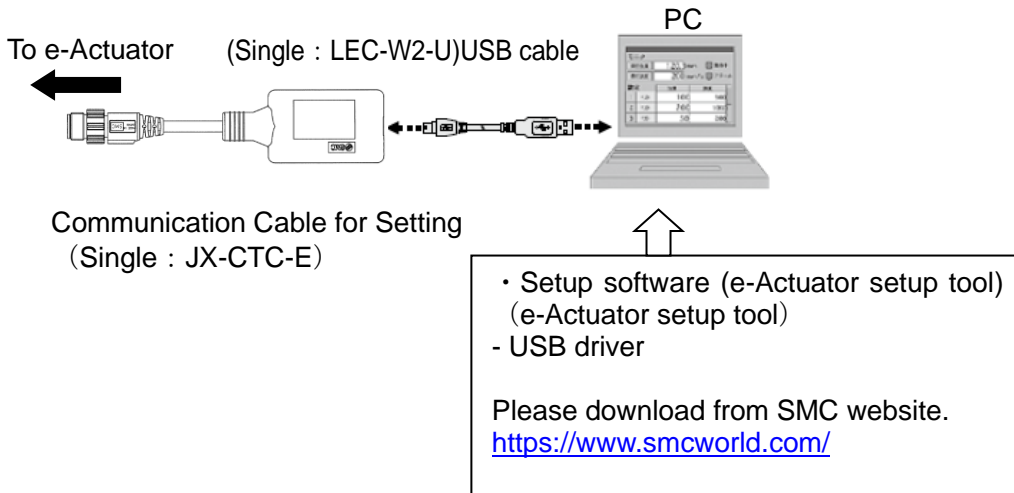
M12  
8-pin socket  
A code  
Normal key



## 9.3 Setup communication cable

### JX-CT-E

\*A set of the setup communication cable and USB cable.



## 9.4 Configuration software

### e-Actuator setup tool

#### ■ Operating environment

OS	Windows®10(64bit) Windows®11(64bit)
Communication interface	USB1.1 or USB2.0 port
Display	1024x768 or more

□ Windows®10, and Windows®11 are registered trademarks of United States Microsoft Corporation.

### ⚠ Caution

Please obtain the USB driver and the setup software (e-Actuator setup tool) from SMC website.  
Use the latest version for the setup software.  
Download the upgrade file from SMC website.

<http://www.smcworld.com/>

Revision history
January 2023 : Frist edition
March 2023 : Second edition

# SMC Corporation

4-14-1, Sotokanda, Chiyoda-ku, Tokyo 101-0021 JAPAN

Tel: + 81 3 5207 8249 Fax: +81 3 5298 5362

URL <https://www.smcworld.com>

---

Note: Specifications are subject to change without prior notice and any obligation on the part of the manufacturer.  
© 2023SMC Corporation All Rights Reserved

