



# Operation Manual

## PRODUCT NAME

Fieldbus system  
Ethernet POWERLINK compatible SI unit

## MODEL / Series / Product Number

*EX600-SPL1-X26*  
*EX600-ED#*

**SMC Corporation**

## Table of Contents

Safety Instructions	- 2 -
System Outline	- 8 -
Assembly	- 10 -
Mounting and Installation	- 12 -
SI Unit	- 15 -
Model Indication and How to Order	- 15 -
Summary of Product parts	- 15 -
Mounting and Installation	- 16 -
Setting and Adjustment	- 17 -
LED Display	- 19 -
Specification	- 22 -
End plate	- 24 -
Model Indication and How to Order	- 24 -
Summary of Product parts	- 24 -
Mounting and Installation	- 25 -
Specification	- 26 -
Maintenance	- 28 -
Configuration	- 29 -
I/O data size	- 32 -
I/O Map	- 33 -
EX600 parameter list	- 36 -
Parameter setting via Manufacture specific Object	- 46 -
Manufacture specific Object	- 49 -
Accessories	- 52 -

## Safety Instructions

These safety instructions are intended to prevent hazardous situations and/or equipment damage. These instructions indicate the level of potential hazard with the labels of "Caution", "Warning" or "Danger". They are all important notes for safety and must be followed in addition to International standards (ISO/IEC)<sup>\*1)</sup> and other safety regulations.

\*1) ISO 4414: Pneumatic fluid power -- General rules relating to systems.

ISO 4413: Hydraulic fluid power -- General rules relating to systems.

IEC 60204-1: Safety of machinery -- Electrical equipment of machines. (Part 1: General requirements)

ISO 10218-1992: Manipulating industrial robots -Safety.

etc.



**Caution :**

CAUTION indicates a hazard with a low level of risk which, if not avoided, could result in minor or moderate injury.



**Warning :**

WARNING indicates a hazard with a medium level of risk which, if not avoided, could result in death or serious injury.



**Danger :**

DANGER indicates a hazard with a high level of risk which, if not avoided, will result in death or serious injury.



### Warning

**1. The compatibility of the product is the responsibility of the person who designs the equipment or decides its specifications.**

Since the product specified here is used under various operating conditions, its compatibility with specific equipment must be decided by the person who designs the equipment or decides its specifications based on necessary analysis and test results. The expected performance and safety assurance of the equipment will be the responsibility of the person who has determined its compatibility with the product. This person should also continuously review all specifications of the product referring to its latest catalogue information, with a view to giving due consideration to any possibility of equipment failure when configuring the equipment.

**2. Only personnel with appropriate training should operate machinery and equipment.**

The product specified here may become unsafe if handled incorrectly. The assembly, operation and maintenance of machines or equipment including our products must be performed by an operator who is appropriately trained and experienced.

**3. Do not service or attempt to remove product and machinery/equipment until safety is confirmed.**

1. The inspection and maintenance of machinery/equipment should only be performed after measures to prevent falling or runaway of the driven objects have been confirmed.
2. When the product is to be removed, confirm that the safety measures as mentioned above are implemented and the power from any appropriate source is cut, and read and understand the specific product precautions of all relevant products carefully.
3. Before machinery/equipment is restarted, take measures to prevent unexpected operation and malfunction.

**4. Contact SMC beforehand and take special consideration of safety measures if the product is to be used in any of the following conditions.**

1. Conditions and environments outside of the given specifications, or use outdoors or in a place exposed to direct sunlight.
2. Installation on equipment in conjunction with atomic energy, railways, air navigation, space, shipping, vehicles, military, medical treatment, combustion and recreation, or equipment in contact with food and beverages, emergency stop circuits, clutch and brake circuits in press applications, safety equipment or other applications unsuitable for the standard specifications described in the product catalogue.
3. An application which could have negative effects on people, property, or animals requiring special safety analysis.
4. Use in an interlock circuit, which requires the provision of double interlock for possible failure by using a mechanical protective function, and periodical checks to confirm proper operation.

 **Caution****The product is provided for use in manufacturing industries.**

The product herein described is basically provided for peaceful use in manufacturing industries. If considering using the product in other industries, consult SMC beforehand and exchange specifications or a contract if necessary.  
If anything is unclear, contact your nearest sales branch.

**Limited warranty and Disclaimer/Compliance Requirements**

The product used is subject to the following "Limited warranty and Disclaimer" and "Compliance Requirements".

Read and accept them before using the product.

**Limited warranty and Disclaimer**

1. The warranty period of the product is 1 year in service or 1.5 years after the product is delivered, whichever is first. <sup>\*2)</sup>

Also, the product may have specified durability, running distance or replacement parts. Please consult your nearest sales branch.

2. For any failure or damage reported within the warranty period which is clearly our responsibility, a replacement product or necessary parts will be provided.

This limited warranty applies only to our product independently, and not to any other damage incurred due to the failure of the product.

3. Prior to using SMC products, please read and understand the warranty terms and disclaimers noted in the specified catalogue for the particular products.

\*2) Vacuum pads are excluded from this 1 year warranty.

A vacuum pad is a consumable part, so it is warranted for a year after it is delivered.

Also, even within the warranty period, the wear of a product due to the use of the vacuum pad or failure due to the deterioration of rubber material are not covered by the limited warranty.

**Compliance Requirements**

1. The use of SMC products with production equipment for the manufacture of weapons of mass destruction (WMD) or any other weapon is strictly prohibited.

2. The exports of SMC products or technology from one country to another are governed by the relevant security laws and regulation of the countries involved in the transaction. Prior to the shipment of a SMC product to another country, assure that all local rules governing that export are known and followed.

## Operator

- ◆ This operation manual is intended for those who have knowledge of machinery using pneumatic equipment, and have sufficient knowledge of assembly, operation and maintenance of such equipment. Only those persons are allowed to perform assembly, operation and maintenance.
- ◆ Read and understand this operation manual carefully before assembling, operating or providing maintenance to the product.

### ■ Safety Instructions

#### **Warning**

- Do not disassemble, modify (including changing the printed circuit board) or repair.  
An injury or failure can result.
- Do not operate or set with wet hands.  
This may lead to an electric shock.
- Do not operate the product outside of the specifications.  
Do not use for flammable or harmful fluids.  
Fire, malfunction, or damage to the product can result.  
Verify the specifications before use.
- Do not operate in an atmosphere containing flammable or explosive gases.  
Fire or an explosion can result.  
This product is not designed to be explosion proof.
- If using the product in an interlocking circuit:
  - Provide a double interlocking system, for example a mechanical system.
  - Check the product regularly for proper operation.Otherwise malfunction can result, causing an accident.
- The following instructions must be followed during maintenance:
  - Turn off the power supply.
  - Stop the air supply, exhaust the residual pressure and verify that the air is released before performing maintenance.Otherwise an injury can result.

## Caution

### ■ When handling the unit or assembling/replacing units:

- Do not touch the sharp metal parts of the connector or plug for connecting units.
- Take care not to hit your hand when disassembling the unit.  
The connecting portions of the unit are firmly joined with seals.
- When joining units, take care not to get fingers caught between units.

An injury can result.

### ■ After maintenance is complete, perform appropriate functional inspections.

Stop operation if the equipment does not function properly.

Safety cannot be assured in the case of unexpected malfunction.

### ■ Provide grounding to assure the safety and noise resistance of the Fieldbus system.

Individual grounding should be provided close to the product with a short cable.

## ■ NOTE

○ Follow the instructions given below when designing, selecting and handling the product.

- The instructions on design and selection (installation, wiring, environment, adjustment, operation, maintenance, etc.) described below must also be followed.

#### \*Product specifications

- The direct current power supply to combine should be UL1310 Class 2 power supply when conformity to UL is necessary.
- Use the specified voltage.  
Otherwise failure or malfunction can result.
- Reserve a space for maintenance.  
Allow sufficient space for maintenance when designing the system.
- Do not remove any nameplates or labels.  
This can lead to incorrect maintenance, or misreading of the operation manual, which could cause damage or malfunction to the product.  
It may also result in non-conformity to safety standards.
- Beware of inrush current when the power supply is turned on.  
Some connected loads can apply an initial charge current which will activate the over current protection function, causing the unit to malfunction.

## ● Product handling

### \*Installation

- Do not drop, hit or apply excessive shock to the SI unit.  
Otherwise damage to the product can result, causing malfunction.
- Tighten to the specified tightening torque.  
If the tightening torque is exceeded the mounting screws may be broken.  
IP67 protection cannot be guaranteed if the screws are not tightened to the specified torque.
- If a large manifold valve is mounted, lift the unit so that stress is not applied to the connecting part while transporting.  
The stress may cause breakage of the connecting part. The unit may become very heavy depending on the combination. Transportation/installation shall be performed by multiple operators.
- Never mount a product in a location that will be used as a foothold.  
The product may be damaged if excessive force is applied by stepping or climbing onto it.

### \*Wiring

- Avoid repeatedly bending or stretching the cables, or placing heavy load on them.  
Repetitive bending stress or tensile stress can cause breakage of the cable.
- Wire correctly.  
Incorrect wiring can break the product.
- Do not perform wiring while the power is on.  
Otherwise damage to the SI unit and/or input or output device can result, causing malfunction.
- Do not route wires and cables together with power or high voltage cables.  
Otherwise the SI unit and/or input or output device can malfunction due to interference of noise and surge voltage from power and high voltage cables to the signal line.  
Route the wires (piping) of the SI unit and/or input or output device separately from power or high voltage cables.
- Confirm proper insulation of wiring.  
Poor insulation (interference from another circuit, poor insulation between terminals, etc.) can lead to excess voltage or current being applied to the product, causing damage.
- Take appropriate measures against noise, such as using a noise filter, when the Fieldbus system is incorporated into equipment.  
Otherwise noise can cause malfunction.

### \*Environment

- Select the proper type of protection according to the environment of operation.  
IP67 protection is achieved when the following conditions are met.
  - (1) The units are connected properly with fieldbus cable with M12 connector and power cable with M12 (M8) connector.
  - (2) Suitable mounting of each unit and manifold valve.
  - (3) Be sure to fit a waterproof cap on any unused connectors.  
If using in an environment that is exposed to water splashes, please take measures such as using a cover.  
Do not use in an environment where moisture or water vapor are present. Otherwise failure and malfunction can result.
- Do not use in a place where the product could be splashed by oil or chemicals.  
If the product is to be used in an environment containing oils or chemicals such as coolant or cleaning solvent, even for a short time, it may be adversely affected (damage, malfunction etc.).
- Do not use the product in an environment where corrosive gases or fluids could be splashed.  
Otherwise damage to the product and malfunction can result.
- Do not use in an area where surges are generated.  
If there is equipment generating large surge near the unit (magnetic type lifter, high frequency inductive furnace, welding machine, motor, etc.), this can cause deterioration of the internal circuitry element of the unit or result in damage. Take measures against the surge sources, and prevent the lines from coming into close contact.

- When a surge-generating load such as a relay, valve or lamp is driven directly, use a product with a built-in surge absorbing element.  
Direct drive of a load generating surge voltage can damage the unit.
- The product is CE marked, but not immune to lightning strikes. Take measures against lightning strikes in the system.
- Prevent foreign matter such as dust or wire debris from getting inside the product.
- Mount the product in a place that is not exposed to vibration or impact.  
Otherwise failure or malfunction can result.
- Do not use the product in an environment that is exposed to temperature cycle.  
Heat cycles other than ordinary changes in temperature can adversely affect the inside of the product.
- Do not expose the product to direct sunlight.  
If using in a location directly exposed to sunlight, shade the product from the sunlight.  
Otherwise failure or malfunction can result.
- Keep within the specified ambient temperature range.  
Otherwise malfunction can result.
- Do not operate close to a heat source, or in a location exposed to radiant heat.  
Otherwise malfunction can result.

**\*Adjustment and Operation**

- Set the switches by using a sharp-pointed screwdriver etc. When setting the switch, do not touch other unrelated parts.  
This can cause parts damage or malfunction due to a short circuit.
- Perform settings suitable for the operating conditions.  
Incorrect setting can cause operation failure.  
(Refer to page 17 for the Setting and Adjustment.)
- Please refer to the PLC manufacturer's manual etc. for details of programming and addresses.  
For the PLC protocol and programming refer to the relevant manufacturer's documentation.

**\*Maintenance**

- Turn off the power supply, stop the supplied air, exhaust the residual pressure and verify the release of air before performing maintenance.  
There is a risk of unexpected malfunction.
- Perform regular maintenance and inspections.  
There is a risk of unexpected malfunction.
- After maintenance is complete, perform appropriate functional inspections.  
Stop operation if the equipment does not function properly.  
Otherwise safety is not assured due to an unexpected malfunction or incorrect operation.
- Do not use solvents such as benzene, thinner etc. to clean each unit.  
They could damage the surface of the body and erase the markings on the body.  
Use a soft cloth to remove stains.  
For heavy stains, use a cloth soaked with diluted neutral detergent and fully squeezed, then wipe up the stains again with a dry cloth.



## System Outline

### System configuration

The EX600 range of units can be connected to various types of fieldbus to realize the reduction of input or output device wiring and the distributed control system. The unit communicates with the fieldbus through the SI unit. One SI unit can be connected with manifold valves with up to 32 outputs and the input • output • I/O units with maximum 10 units.

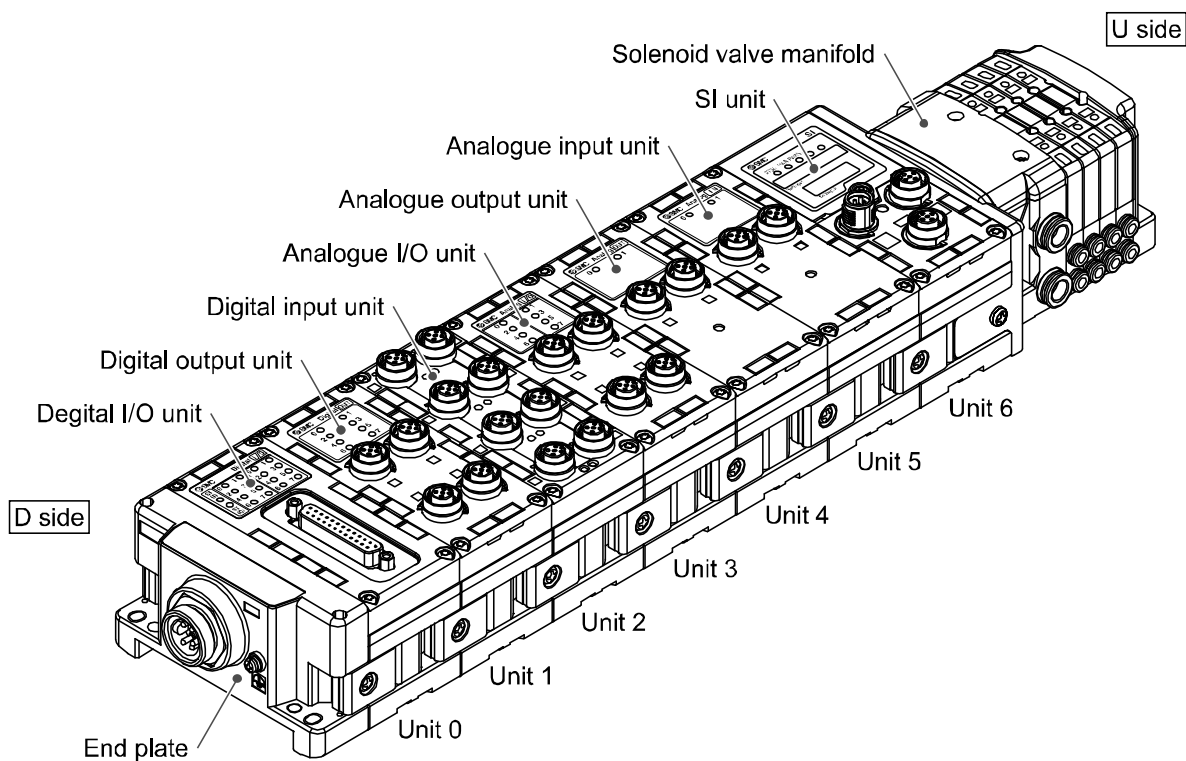

Name	Function
SI unit	Performs fieldbus communication and solenoid valve manifold ON/OFF output.
Digital input unit	For connecting sensors with switch output capability. PNP and NPN types are available.
Digital output unit	For connecting output device such as solenoid valves, lamps, buzzers, etc. PNP and NPN types are available.
Digital I/O unit	This unit has both digital input and output functions. PNP and NPN types are available.
Analog input unit	For connecting sensors with analog output capability.
Analog output unit	This can be connected to the equipment which can read analog input.
Analog I/O unit	This unit has both analog input and output functions.
End plate	Connected at EX600 Manifold's D side, incorporating the power supply connection.
Solenoid valve manifold	An assembly of solenoid valves. One connector is used as the electric connection to all connected valves.

## ■ Definition and terminology

	Terminology	Definition
100	100BASE-TX	Standard of LAN transmission line with communication speed of 100Mbps.
A	AD value	The signal from the analog input device is converted to digital, and displayed in decimal and hexadecimal. These hexadecimal and decimal values are also outputted to the analog output device.
C	Current consumption	The current necessary to operate each unit.
D	DIN rail	A metal rail conforming with DIN (German) standard.
	D Side	The side connected to the End plate when the product is connected to a manifold.
E	Enclosure (IP□□)	Abbreviation of international (ingress) protection. A standard related to the protection from external objects (hands, steel ball, steel wire, dust, water, etc.) applied to the product.
F	FE	Abbreviation of functional earth.
	Fieldbus	The protocol that uses digital communication to exchange signals between field equipment (instruments and actuators) running on site and a PLC.
H	Half duplex	Communication system that sends and receives data in one direction at a time.
I	IP address	A 32 bit digit sequence which is assigned to identify devices which are connected to the network.
M	MAC address	A unique number inherent to all devices which are connected to POWERLINK.
	Manifold	A form consisting of multiple components. A form made by combining multiple components
N	NPN input	Takes the sensor output that uses the NPN transistor to the signal output line.
	NPN output	The output type that uses an NPN transistor to operate output device. It is also known as a positive common type since a positive potential is applied to the power supply line.
	Number of inputs	The number of points that can receive information from input device (sensor, switch, etc.) .
	Number of outputs	The number of points that can operate output device (solenoid valve, light, motor, etc.) .
O	Open circuit detection	A diagnosis function to detect if the input or output device wiring is disconnected.
P	PLC	Abbreviation of programmable logic controller. A digital computer used for automation of electromechanical processes.
	PNP input	Takes the sensor output that uses the PNP transistor to the signal output part.
	PNP output	The output type that uses a PNP transistor to operate output device. It is also known as a negative common type since a negative potential is applied to the power supply line.
S	Short circuit detection	A diagnosis function to detect an over current due to the short circuit of the output and/or power supply positive line with respect to the GND line.
	Short circuit protection	A function to protect the internal circuit from being broken by an over current due to the short circuit of the output and/or power supply positive line with respect to the GND line.
	SI unit	Abbreviation of serial interface unit. A unit connected to a PLC to communicate input and output data.
U	U Side	The side connected to the solenoid valve when the product is connected to a manifold.

## Assembly

### ● Composing the unit as a manifold

\*: If the unit was purchased as a manifold, the work described in this section is not necessary.

(1) Connect the unit to the end plate.

The Digital unit, Analog unit can be connected in any order.

(Tightening torque: 1.5 to 1.6Nm)

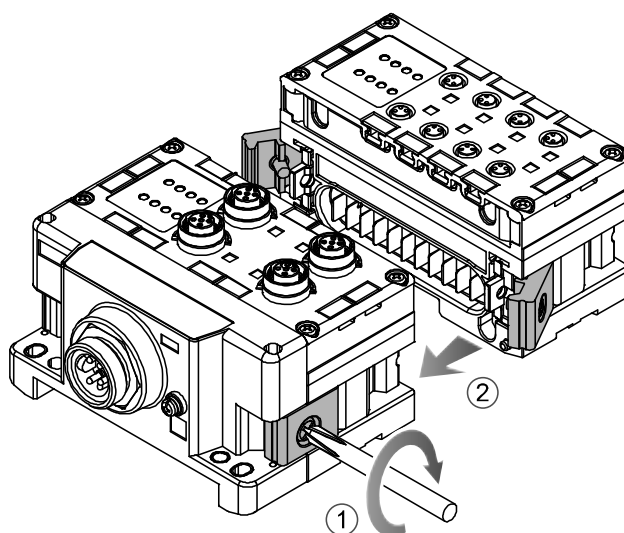

(2) Add more I/O units.

Up to 10 units (including the SI unit) can be connected to one manifold.

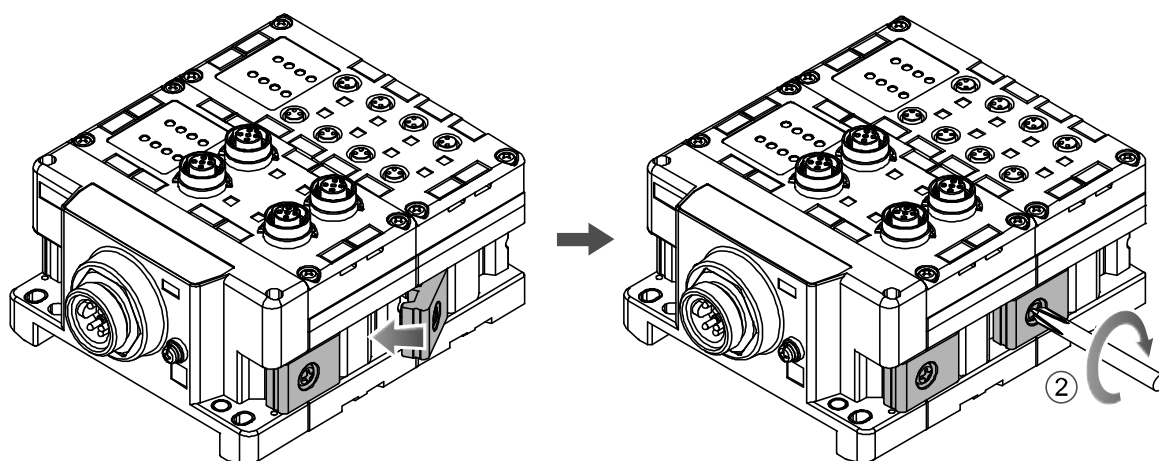

(3) Connecting the SI unit.

After connecting the necessary units, connect the SI unit.

Connecting method is the same as above (1), (2).

### Mounting the valve plate.

Mount the valve plate (EX600-ZMV□) to the valve manifold using the valve set screws. (M3 x 8)  
(Tightening torque: 0.6 to 0.7 Nm)

Screw mounting place	
SV	: 2 places
S0700	: 2 places
VQC1000	: 2 places
VQC2000	: 3 places
VQC4000	: 4 places
VQC5000	: 4 places
SY	: 2 places

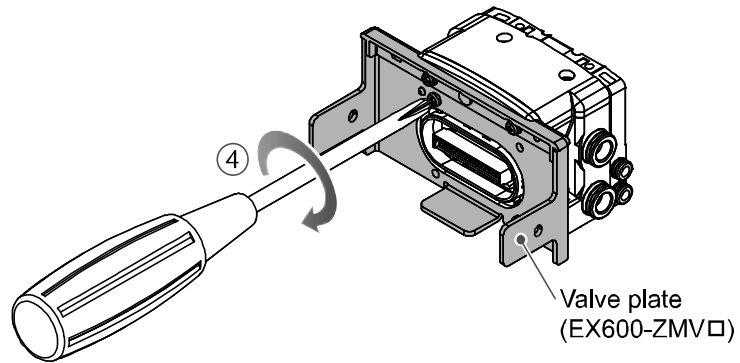

### (5) Connect the SI unit and the valve manifold.

Insert the valve plate to the valve plate set groove on the side of SI unit.  
Then, tighten it with the valve plate set screws (M4 x 6) to fix the plate.  
(Tightening torque: 0.7 to 0.8 Nm)

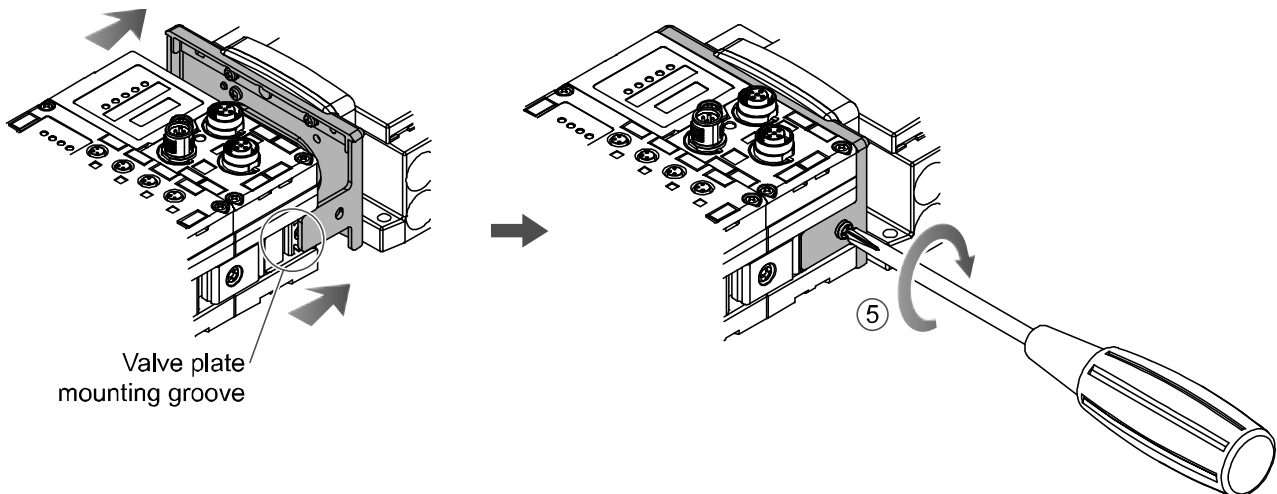

#### ● Precautions for handling

- Please do not connect the unit while the power supply is active. It will cause equipment damage.
- Take care not to drop the nuts of Joint bracket.
- Tighten the screws to the specified torque.

# Mounting and Installation

## ■ Installation

### • Direct mounting

#### (1) Direct mounting

When joining six or more units, fix the middle part of the complete EX600 unit with an intermediate reinforcing brace (EX600-ZMB1) before mounting using 2-M4 x 5 screws.  
(Tightening torque: 0.7 to 0.8 Nm)

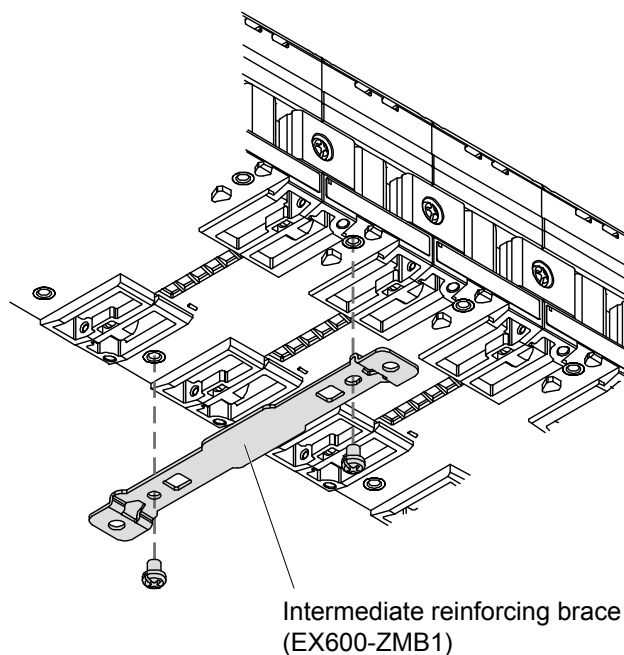

#### (2) Fix and tighten the end plates at one end of the unit. (M4) (Tightening torque: 0.7 to 0.8 Nm)

Fix the end plate at the valve side while referring to the operation manual of the corresponding valve manifold.

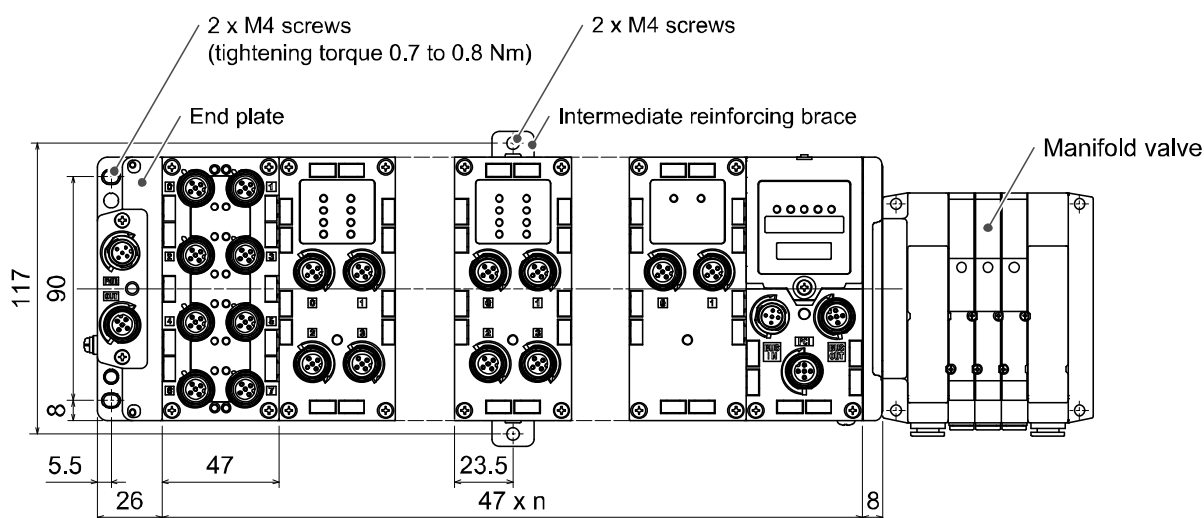

n (Number of connected Units) ≤ 10

### • Precautions for handling

• When joining six or more units, fix the middle part of the complete unit with an intermediate reinforcing brace to prevent incorrect connection between the units due to deflection.

### •DIN rail mounting

(Not available for SY series valves. Refer to the SY catalog.)

- (1) When joining six or more units, fix the middle part of the complete EX600 unit with an intermediate reinforcing brace (EX600-ZMB2) before mounting, using 2-M4 x 6 screws. (Tightening torque: 0.7 to 0.8 Nm)
- (2) Mount the end plate bracket (EX600-ZMA2) to the end plate at the opposite end to the valves, using 2-M4 x 14 screws. (Tightening torque: 0.7 to 0.8 Nm)

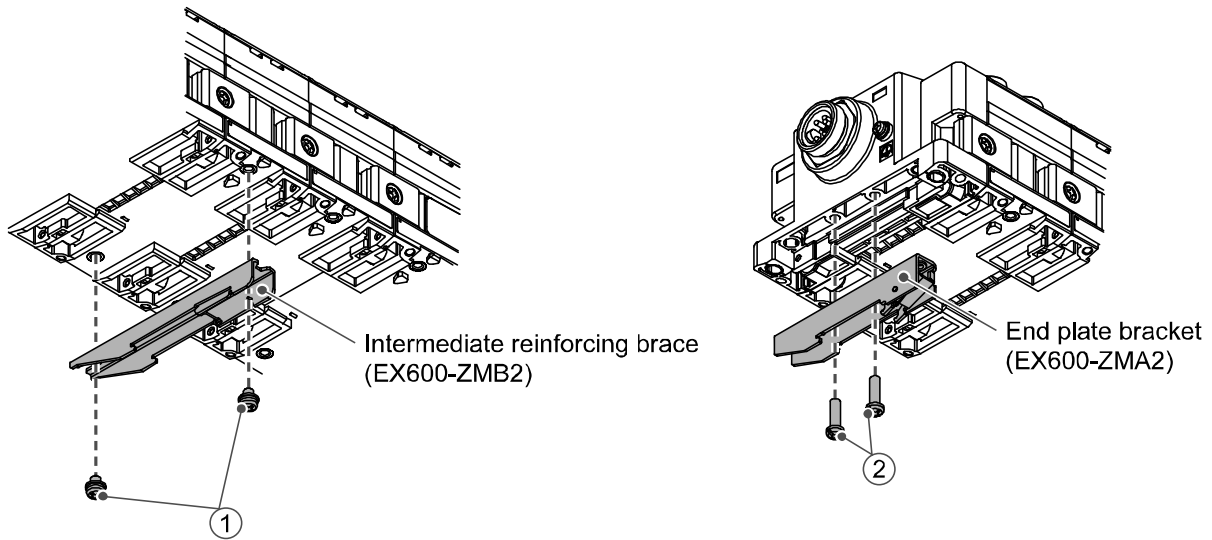

- (3) Hook the DIN rail mounting groove to the DIN rail.
- (4) Press the manifold using its side hooked to the DIN rail as a fulcrum until the manifold is locked.
- (5) Fix the manifold by tightening the DIN rail fixing screws of the EX600-ZMA2. (M4 x 20)

(Tightening torque: 0.7 to 0.8 Nm)

The tightening torque at the valve side depends on the valve type.  
Refer to the operation manual of the corresponding valve manifold.

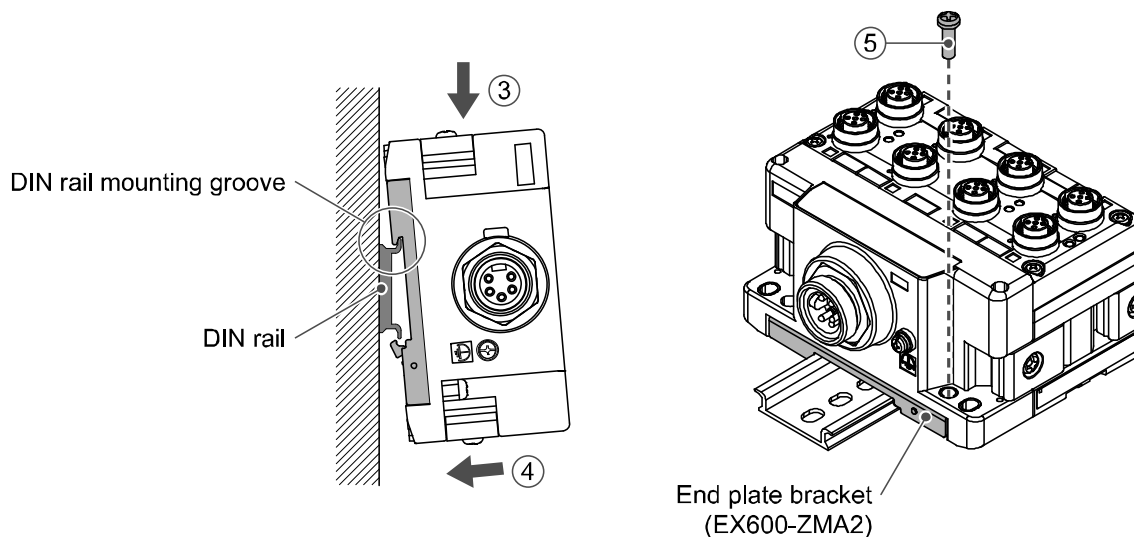

### •Precautions for handling

- When joining six or more units, fix the middle part of the complete unit with an intermediate reinforcing brace to prevent incorrect connection between the units due to deflection.

## ■Wiring

### •Connect the M12 cable.

M12 connector is applicable for SPEEDCON connector. SPEEDCON connector wiring method is explained below.

- (1) Align the mark B on the metal bracket of the cable side connector (plug/socket) with the mark A.
- (2) Align the mark C on the unit and insert the connector into the unit vertically.  
If they are not aligned, the connector cannot be joined properly.
- (3) When the mark B of the connector has been turned 180 degrees (1/2 turn), wiring is completed.

Confirm that the connection is not loose. If turned too far, it will become hard to remove the connector.

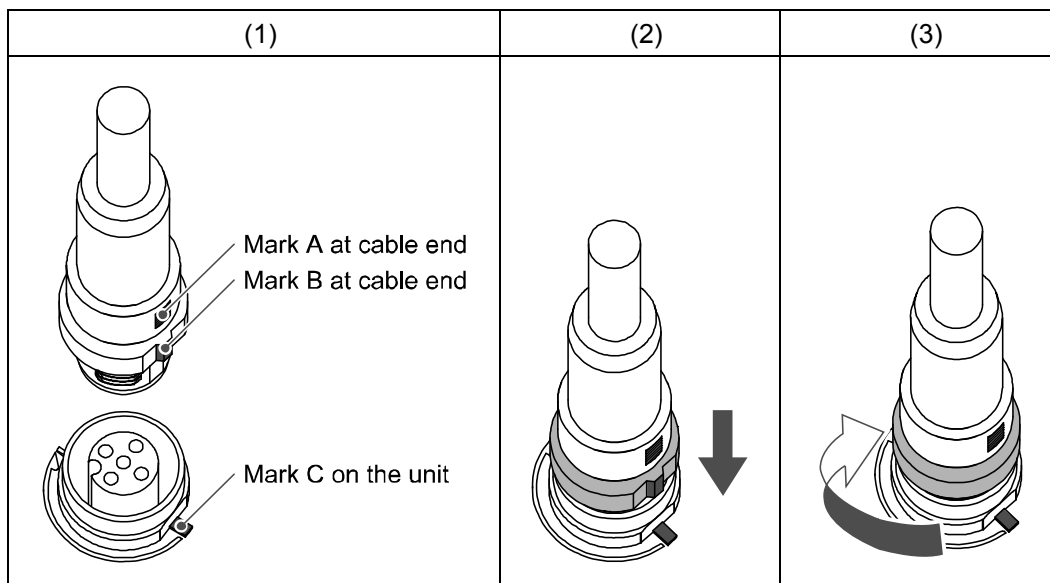

### •Mounting the marker

Signal name of the input or output devices and unit address can be written to the marker, and it can be installed to each unit.

Mount the marker (EX600-ZT1) into the marker groove as required.

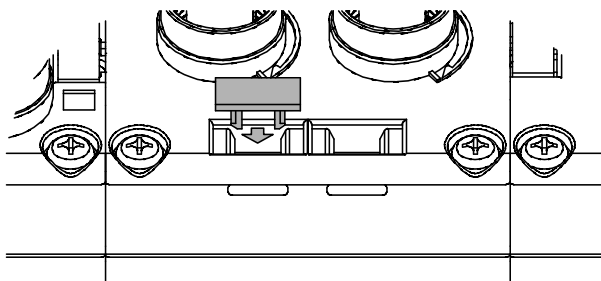

## SI unit

### Model Indication and How to Order

**EX600-SPL1-X26**

Protocol	Ethernet POWERLINK
Polarity of output	PNP ( Negative common )

### Summary of Product parts

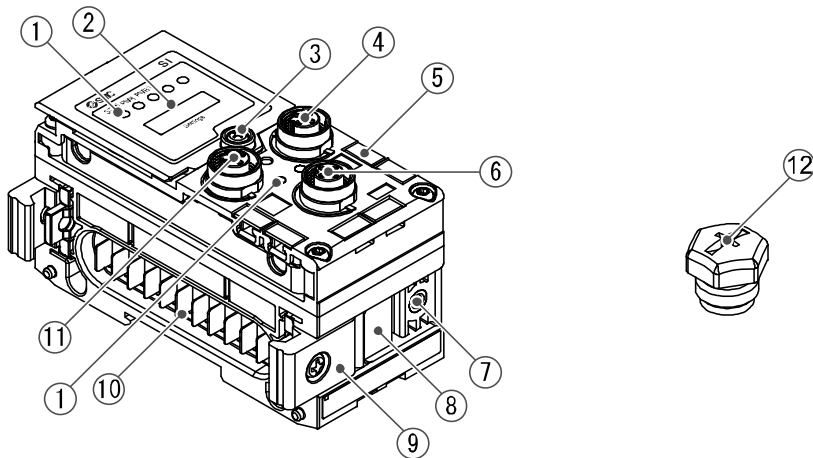

No.	Description	Function
1	Status display LED	Displays the status of the unit.
2	Display cover	Open for the setting of switch.
3	Display cover tightening screw	Loosen to open the display cover.
4	Connector (BUS OUT)	Connects the cable for fieldbus outputs. (M12, 5pin, socket : SPEEDCON)
5	Marker groove	Groove to mount a marker.
6	Connector (PCI)	Connector for Handheld Terminal.
7	Valve plate mounting screw hole	Fixes the valve plate.
8	Valve plate mounting groove	Groove to insert the valve plate into.
9	Joint bracket	Bracket for joining to adjacent units.
10	Unit connector (plug)	Transmits signals and power supplies to adjacent units.
11	Connector (BUS IN)	Connects the cable for fieldbus inputs. (M12, 5pin, socket : SPEEDCON)
12	Seal cap (2 pcs.)	Mounted on to unused connectors (BUS OUT and PCI) .



## Mounting and Installation

### ■ Wiring

#### • Connector pin assignment

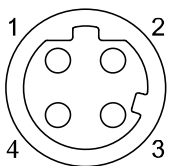
Configuration	Pin number	Signal name
BUS IN / BUS OUT		
	1	TX+
	2	RX+
	3	TX-
	4	RX-

#### ● Precautions for handling

Be sure to fit a seal cap on any unused connectors. Proper use of the seal cap enables the enclosure to achieve IP67 specification.

## Setting and Adjustment

### •Switch operation

- (1) Loosen the display cover screw.
- (2) Open the display cover using a flat head screwdriver, etc.

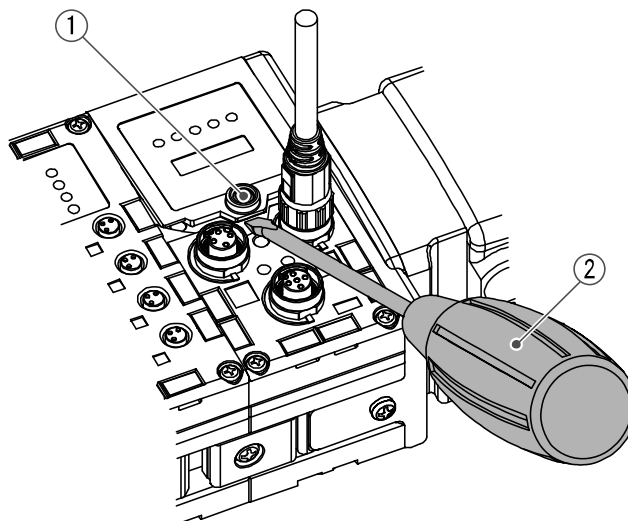

- (3) Set the switch using a small watchmaker's screwdriver with a thin blade, referring to the setting of switch on the following pages.
- (4) After setting the switch, tighten the display cover tightening screw in the reverse order of the above procedure. (Tightening torque: 0.3 to 0.4 Nm)

#### •Precautions for handling

- Turn off the power supply whilst setting the switch.
- If there is foreign matter or water droplets around the display cover, clean it off before opening the cover.
- When setting the switch, do not touch other unrelated parts. This can cause parts damage or malfunction due to a short circuit.
- All default settings are OFF. Perform the setting of the switch before using this product.

## •Switch setting

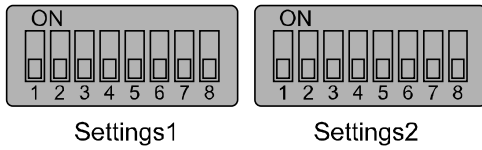

Settings1		Settings2	
1	Hold / Clear setting	1	Node ID setting
2	Reserved	2	
3		3	
4		4	
5		5	
6		6	
7		7	
8		8	

### •Precautions for handling

- Handle the switch with care. Excessive force can break the switch.
- 2 to 8 of the Settings1 switch are not used. (Never turn it ON.)

### (1) Hold/Clear setting

Sets the output status when the fieldbus has a communication error.

Settings 1	Content
1	
OFF	Output is OFF. (Default setting)
ON	Holds the output.

### (2) Node ID setting

The Node ID setting range is 1~239.

The IP address is made up as 192.168.100.[Node ID].

Settings2								Node ID	IP address
1	2	3	4	5	6	7	8		
ON	OFF	OFF	OFF	OFF	OFF	OFF	OFF	1	192.168.100.1
OFF	ON	OFF	OFF	OFF	OFF	OFF	OFF	2	192.168.100.2
ON	ON	OFF	OFF	OFF	OFF	OFF	OFF	3	192.168.100.3
:	:	:	:	:	:	:	:	:	:
ON	OFF	ON	ON	OFF	ON	ON	ON	237	192.168.100.237
OFF	ON	ON	ON	OFF	ON	ON	ON	238	192.168.100.238
ON	ON	ON	ON	OFF	ON	ON	ON	239	192.168.100.239

## LED Display

The status display LED displays the power supply and communication status.  
Various kinds of status can be checked as follows:

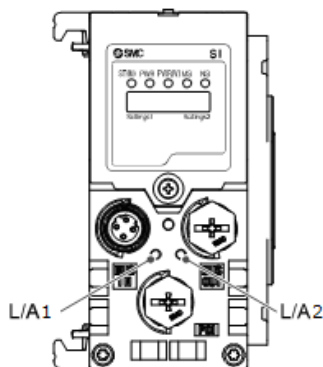



Display	Content
ST (M)	Displays the diagnostic status of the unit.
PWR	Displays the status of the power supply voltage for control and input.
PWR (V)	Displays the status of the power supply voltage for outputs.
BS	Displays the Communication status.
BE	Displays the Communication error
L/A1	Displays the communication status of the BUS IN side.
L/A2	Displays the communication status of the BUS OUT side.



### •ST(M)-LED

LED display	Content
○ OFF	The power supply for control and input is OFF.
● Green ON	Normal operation.
⊙ Green flashing	Diagnostic error of I/O unit is detected.
⊙ Red flashing	Valve is short circuited or disconnected.
⊙ Red/green flashing alternately	Detect a communication error between SI unit and I/O unit.
● Red ON	SI unit has failed.













•PWR-LED

LED display	Content
 Green ON	The power supply voltage for control and input is properly.
 Red ON	The power supply voltage for control and input is out of range. (When diagnostic parameter is enabled)

•PWR(V)-LED

LED display	Content
 OFF	The power supply voltage for output is OFF or out of range. (When diagnostic parameter is disabled)
 Green ON	The power supply for output is properly.
 Red ON	The power supply voltage for output is OFF or out of range. (When diagnostic parameter is enabled)

•POWERLINK status

	LED display	Content
BS	 OFF	SI Unit is initializing or not active.
	 Green flashing	Fast flashing (ON 50msec, OFF 50msec) : Basic Ethernet state No POWERLINK traffic has been detected.
		Single flash: Pre-Operational 1. Only asynchronous data.
		Double flash: Pre-Operational 2. Asynchronous and synchronous data. No process data.
		Triple flash: Ready to operate. No process data.
	Slow flash (ON 200msec, OFF 200msec) : Stopped No process data.	
 Green ON	Operation. Full operational. Process data is sent and received.	
BE	 OFF	No error.
	 Red flashing	Node ID set outside 1~239 range.
	 Red ON	SI Unit receives defective Ethernet frames. An existing POWERLINK communication has been separated.
L/A1	 OFF	BUS IN side: No Link, No Activity
	 Green ON	BUS IN side: Link, No Activity
	 Green flashing	BUS IN side: Link, Activity
L/A2	 OFF	BUS OUT side: No Link, No Activity
	 Green ON	BUS OUT side: Link, No Activity
	 Green flashing	BUS OUT side: Link, Activity

# Specification

## ■ Specifications

Model		EX600-SPL1-X26
General	Enclosure	IP67 (With manifold assembled) *1
	Housing material	PBT
	Weight	300 g or less
	Operating temperature range	-10 to 50 °C
	Storage temperature range	-20 to 60 °C
	Operating humidity range	35 to 85% RH (No condensation)
	Max. number of I/O Unit	9
	Standard	CE marking, RoHS
Power supply (Control and input)		24 VDC, Class2, 2 A
Power supply (Output)		24 VDC, Class2, 2 A
Solenoid valve	Applicable series	VQC1000/2000/4000/5000, SV1000/2000/3000, SY3000/5000/7000, S0700
	Max. number of solenoid valves	32 solenoid coils
	Output type of solenoid	PNP (Negative common)
	Connected load	Solenoid valve with surge voltage suppressor 24 VDC, 1.0 W or less (SMC)
	Short circuit protection	YES
Fieldbus	Protocol	Ethernet POWERLINK
	Media	100 BASE-TX
	Communication speed	100 Mbps
	Communication type	Half duplex
	Node ID setting method	Dip switch: From 1 to 239
	Vendor ID	FFFF 0007

\*1: All unused connectors must have a seal cap fitted.

■Dimensions

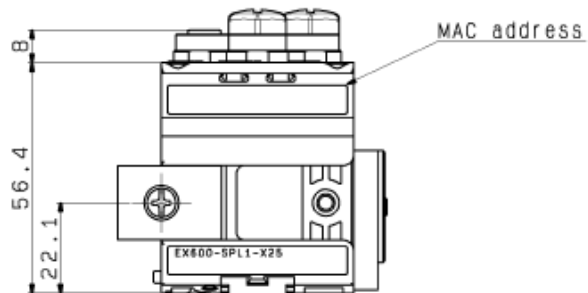
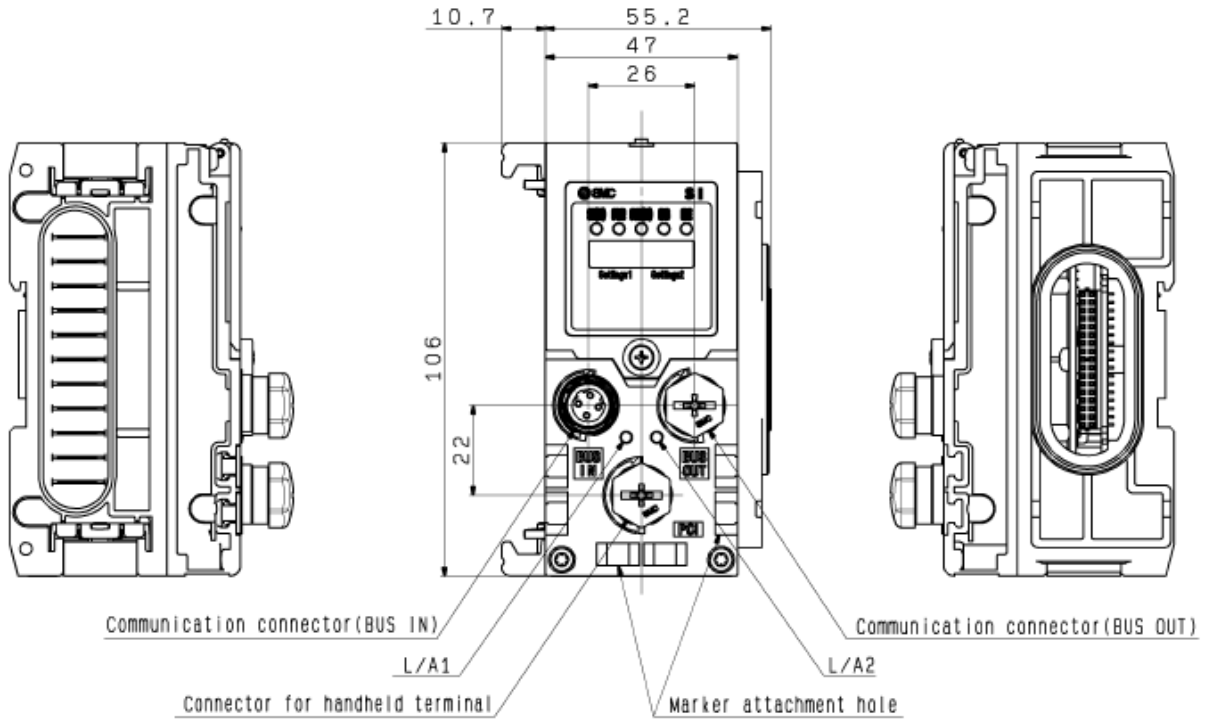



# End plate

## Model Indication and How to Order

**EX600-ED□-□**

End plate at D side

Mounting method

Connector

Symbol	Content
2	M12 (5 pin)
3	7/8 inch (5 pin)

Symbol	Content
Nil	No DIN rail bracket
2	With DIN rail bracket
3	With DIN rail bracket (Specified for SY series)

## Summary of Product parts

•EX600-ED2-□

•EX600-ED3-□

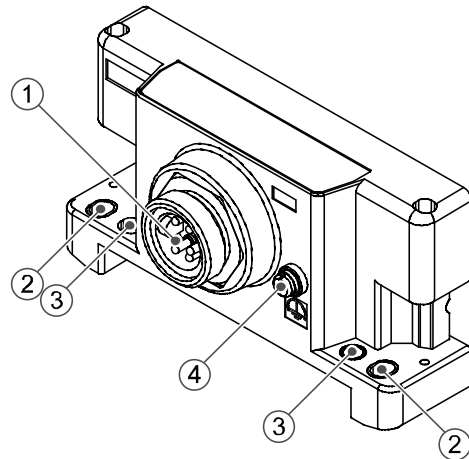
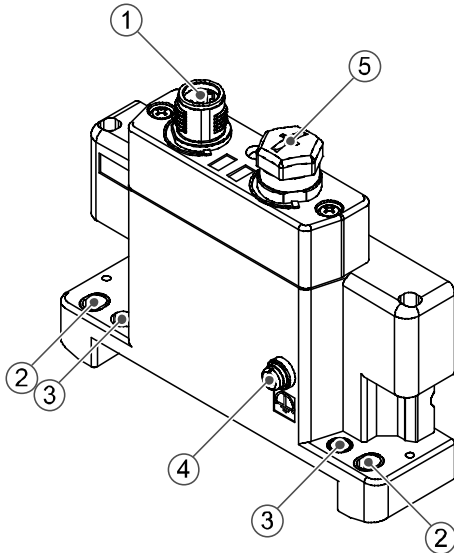

No.	Description	Function
1	Power connector	Connector for power supply to SI unit and I/O unit.
2	Fixing hole for direct mounting	Holes for direct mounting.
3	DIN rail fixing hole	Holes for fix DIN rail mounting.
4	F.E. terminal*1	Functional Earth terminal - must be connected directly to system earth (ground) .
5	Connector (Not used)	Unused connector. Do not remove seal cap.

\*1: Individual grounding should be provided close to the product with a short cable.

# Mounting and Installation

## ■Wiring

### ○Connector pin assignment

#### (1) EX600-ED2-□

Configuration	Pin number	Signal name
	1	24 V (Output)
	2	0 V (Output)
	3	24 V (Control and input)
	4	0 V (Control and input)
	5	FE

#### (2) EX600-ED3-□

Configuration	Pin number	Signal name
	1	0 V (Output)
	2	0 V (Control and input)
	3	FE
	4	24 V (Control and input)
	5	24 V (Output)

### ○Regarding the 2 types of power supply

The power supply consists of two power supply systems as follows:

- Power supply for control and input: Supplying power for control of each unit's power supply for control and also for device connected to input port of Digital and Analog unit.
- Power supply for output: Supplying power for equipment connected to output port of Digital and Analog unit, and also power supply for solenoid valve manifold.

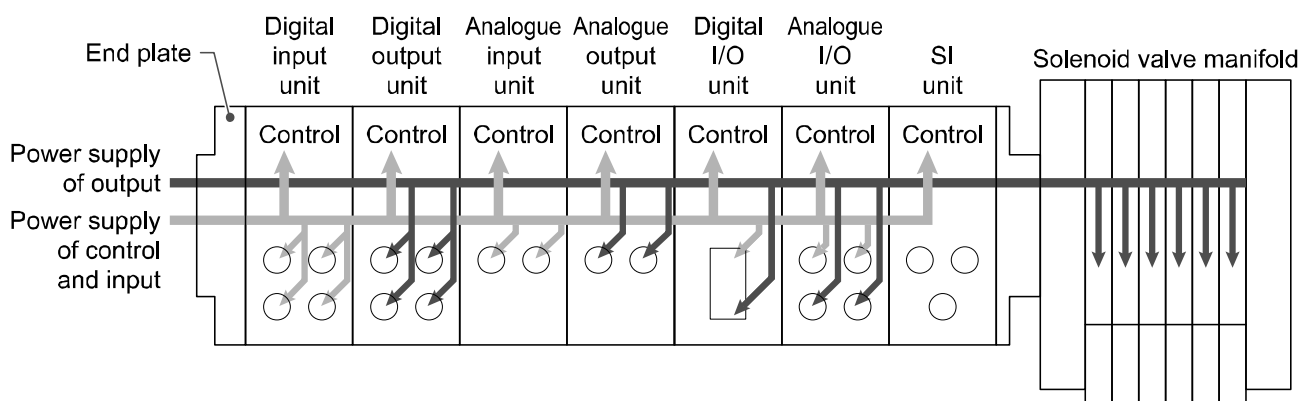

### ●Precautions for handling

Be sure to fit a seal cap on any unused connectors. Proper use of the seal cap enables the enclosure to achieve IP67 specification.

# Specification

## ■ Specifications

Model		EX600-ED2-□	EX600-ED3-□
Power specifications	Power connector	M12 (5 pin) Plug	7/8 inch (5 pin) Plug
	Power supply (Control and input)	24 VDC, ±10%, Class2, 2 A	24 VDC, ±10%, 8 A
	Power supply (Output)	24 VDC, +10/-5%, Class2, 2 A	24 VDC, +10/-5%, 8 A
Environment	Enclosure	IP67 (With manifold assembled) *1	
	Operating temperature range	-10 to 50 °C	
	Storage temperature range	-20 to 60 °C	
	Operating humidity range	35 to 85%RH (No condensation)	
	Withstand voltage	500 VAC for 1 minute between external terminals and FE	
	Insulation resistance	500 VDC, 10 MΩ min. between external terminals and FE	
	Pollution degree	Pollution degree 3	
Standard	CE marking, UL (CSA) , RoHS		
Weight		170 g	175 g

\*1: All unused connectors must have a seal cap fitted.

## ■ Dimensions

### •EX600-ED2-□

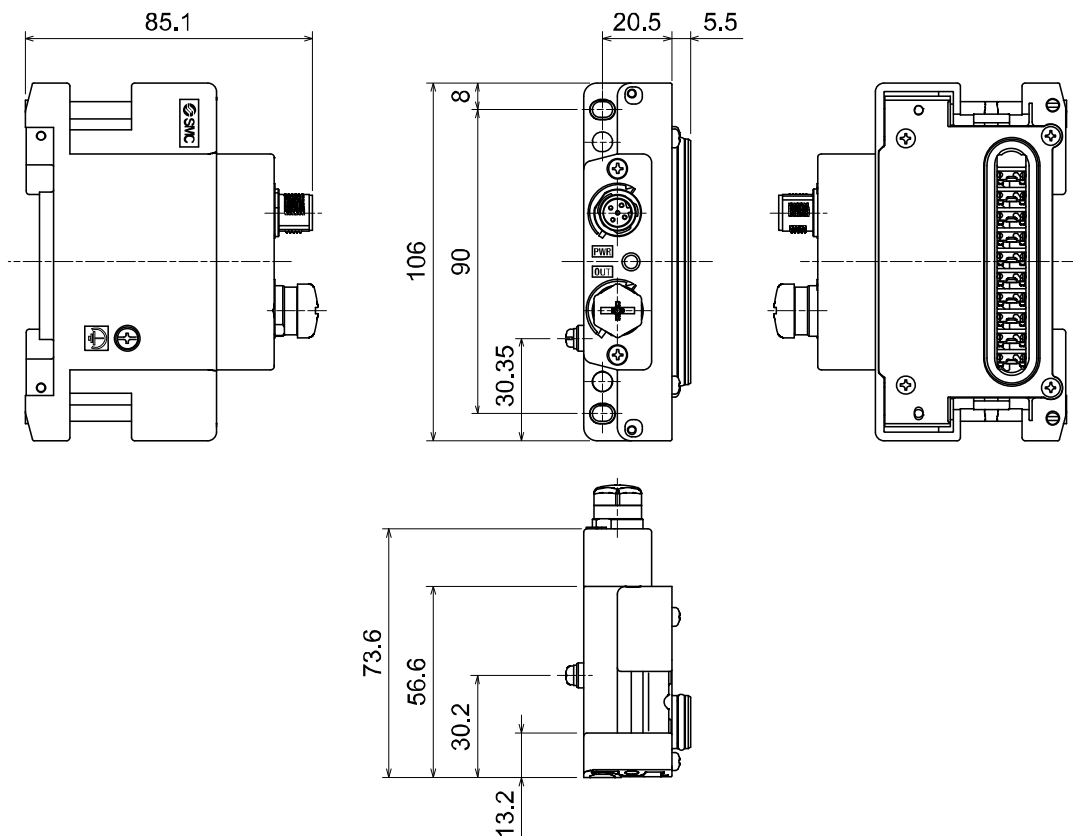

•EX600-ED3-□

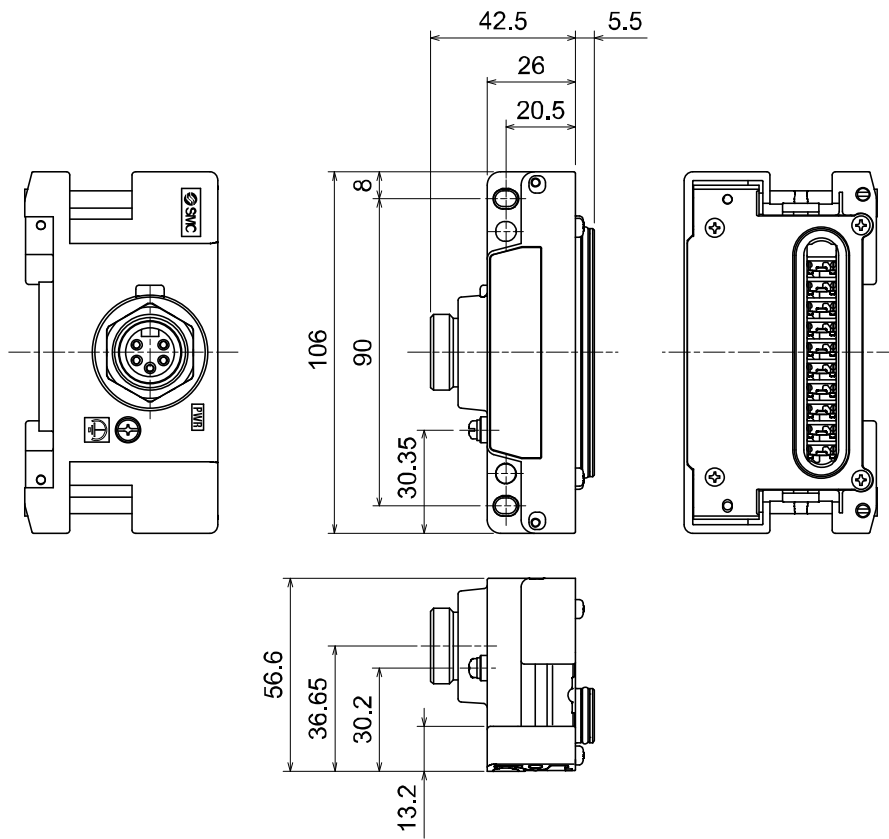

## Maintenance

Turn off the power supply, stop the supplied air, exhaust the residual pressure and verify the release of air before performing maintenance.

### Cleaning method

Use a soft cloth to remove stains.

For heavy stains, use a cloth soaked with diluted neutral detergent and fully squeezed, then wipe up the stains again with a dry cloth.

Do not use solvents such as benzene, thinner etc. to clean each unit.

Inspection item	Content of inspection
Connector/Electric wiring	Connect properly if the connection is loose.
Seal cap	Tighten properly if the connection is loose.
Thread for mounting and installation	If the thread is loose, re-tighten it to the specified torque.
Connection cables	If the cable is broken or any other abnormality is confirmed by appearance, replace the cable with a new one.
Supply source voltage	Check if source voltage within the specification range (24 VDC $\pm$ 10%) is supplied.

### How to reset the product for power cut or forcible de-energizing

Supply power to the product.

The output status just before the power failure is not maintained when power supply is recovered.

Start operation after confirming safety of the entire equipment.

# Configuration

## ■ Configuration layout

EX600 Slot No. is assigned from the end-plate side.

The unit connected to the right of the end-plate is Slot 0.

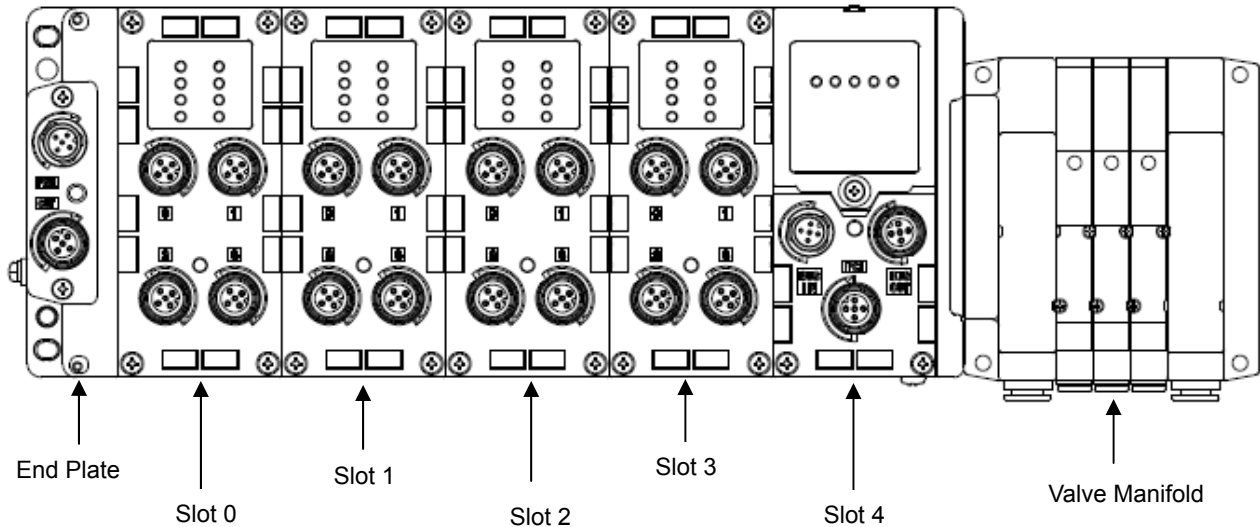

## ■ XDD file

The XDD file is required when configuring the device using B&R's Automation studio.

The XDD file for the EX600 is "FFFF0007\_EX600-SPL1-X26.xdd".

## ■ Configuration using Automation studio

- 1) Select "Import Fieldbus Device..." from "Tools" in the Project Explorer, and install "FFFF0007\_EX600-SPL1-X26.xdd".

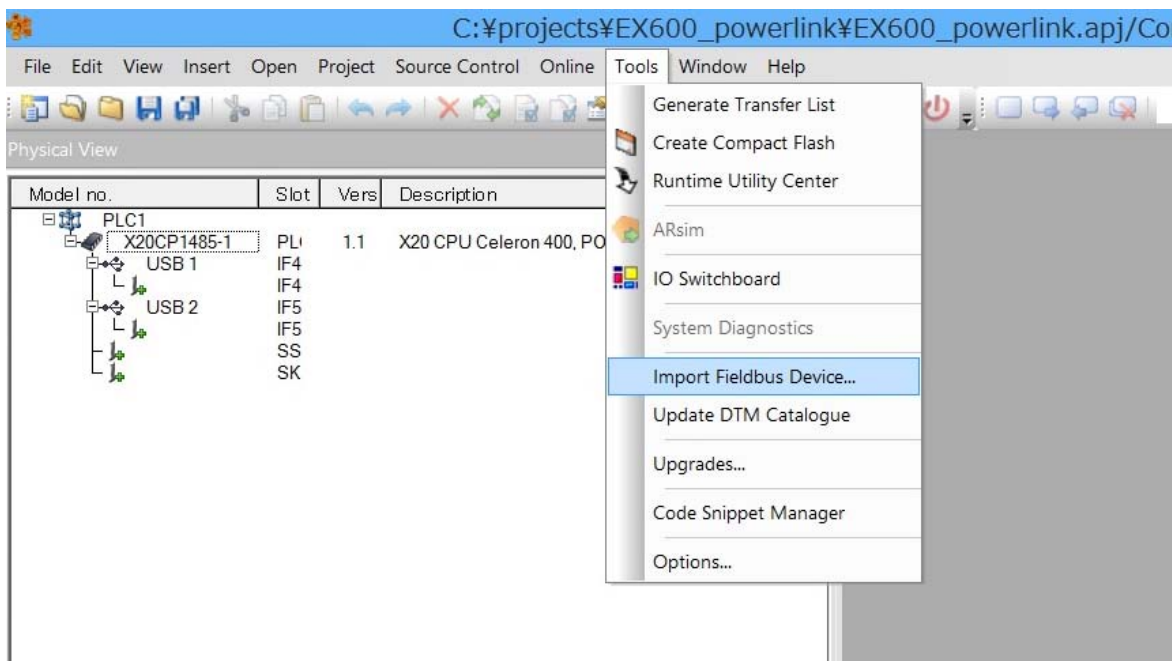

2) Select "Open POWERLINK" by right clicking PLC type.

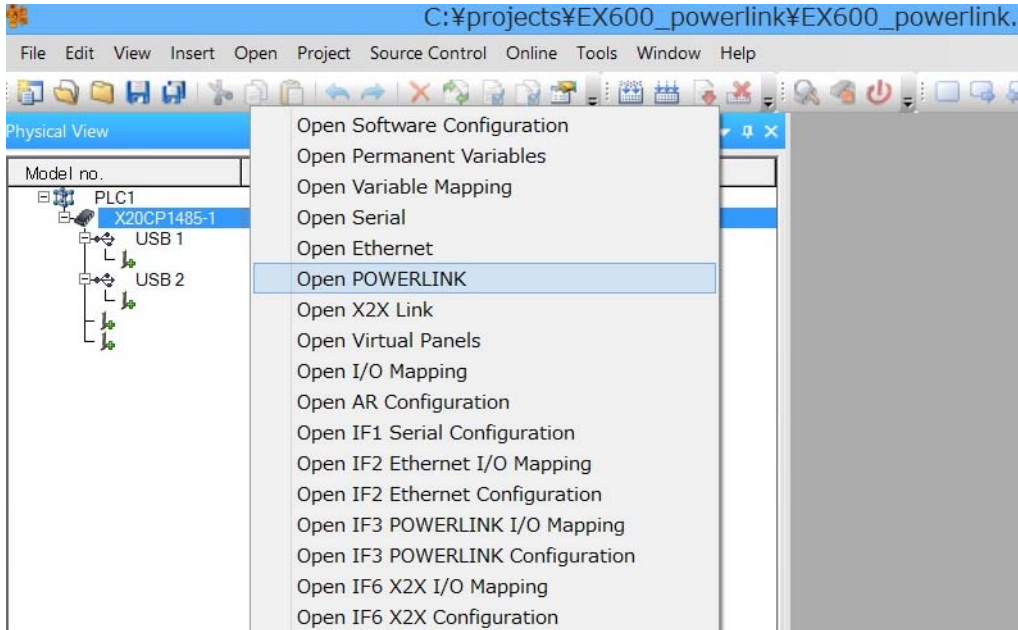

3) Select "Insert" by right clicking on Slave Module IF.

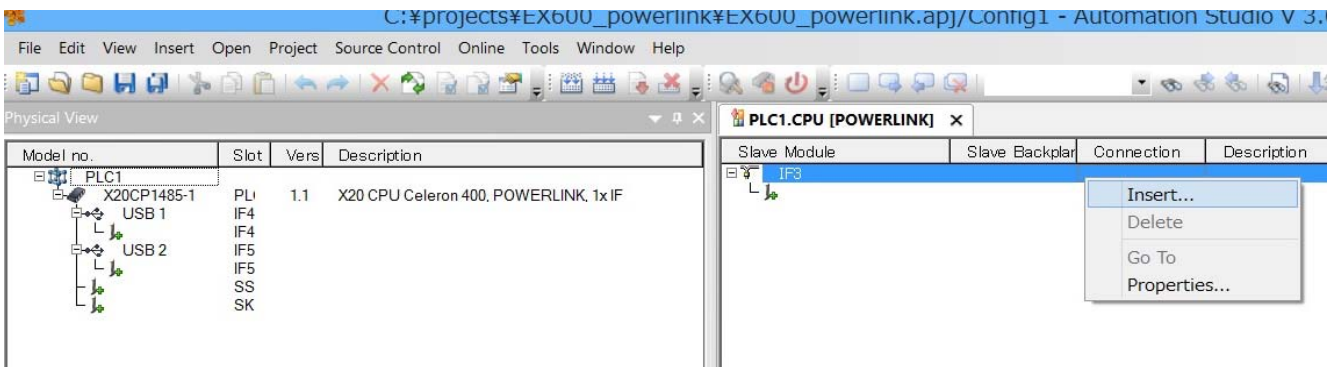

4) Select EX600-SPL1-X26 and click "Next".

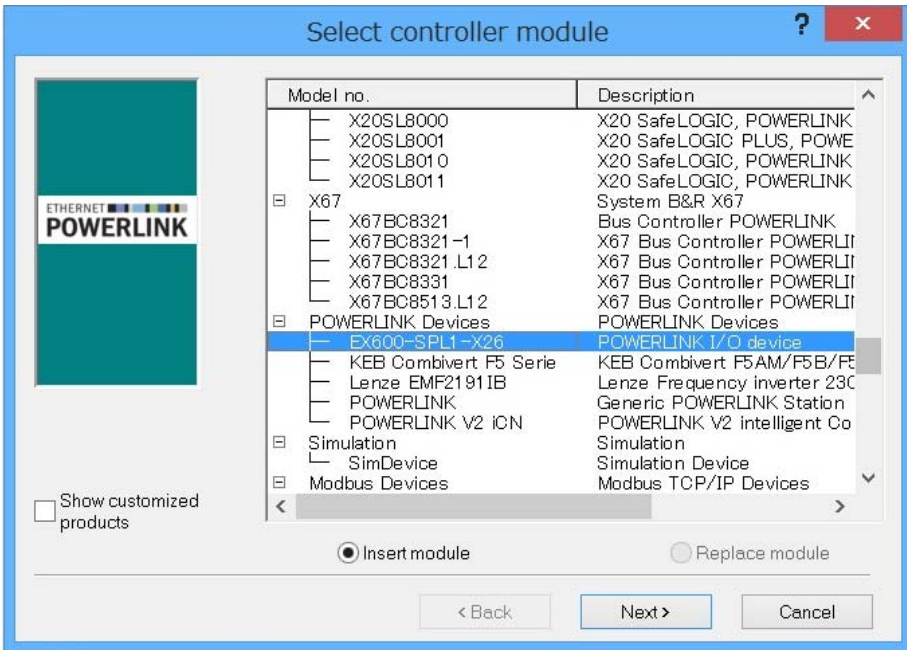

5) Input Node ID set to the EX600-SPL1-X26 in the Enter node number form, click next to complete configuration.

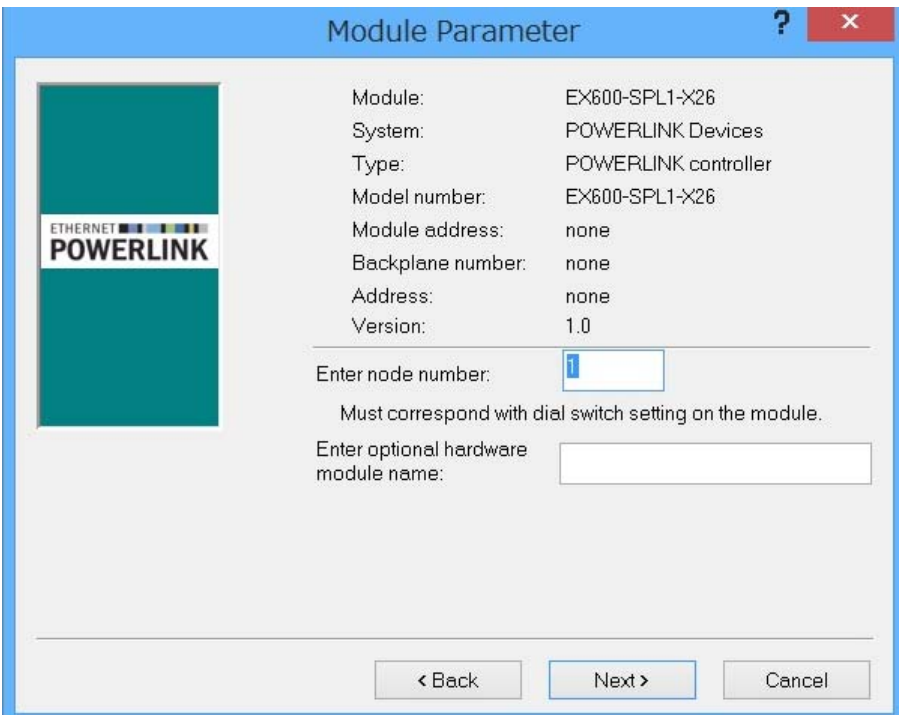



## I/O data size

Each unit of the product has its own I/O occupied word.

Unit	Unit part number	Occupied word size	
		Input	Output
Diagnostic data	System diagnostic	1	0
	Unit diagnostic	1	0
SI unit	EX600-SPL1-X26 (32 outputs)	0	2
Digital input unit	EX600-DX□B (8 inputs)	1	0
	EX600-DX□C (8 inputs)	1	0
	EX600-DX□C1 (8 inputs) (with open circuit detection)	1	0
	EX600-DX□D (16 inputs)	1	0
	EX600-DX□E (16 inputs)	1	0
	EX600-DX□F (16 inputs)	1	0
Digital output unit	EX600-DY□B (8 outputs)	0	1
	EX600-DY□E (16 outputs)	0	1
	EX600-DY□F (16 outputs)	0	1
Digital I/O unit	EX600-DM□E (8 inputs/8 outputs)	1	1
	EX600-DM□F (8 inputs/8 outputs)	1	1
Analog input Unit	EX600-AXA (2 channels)	2 (1 word / 1 channel)	0
Analog output Unit	EX600-AYA (2 channels)	0	2 (1 word / 1 channel)
Analog I/O Unit	EX600-AMB (2/2 channels)	2 (1 word / 1 channel)	2 (1 word / 1 channel)

Note) 1 word is equivalent to 2 bytes.

## I/O Map

I/O map of EX600 is assigned in order starting from the unit on the End plate side.

The unit connected to the right of the end-plate is slot 0.

Input data is allocated to manufacture specific object Index2001h~2020h. Output data is assigned to Index 2065h~2084h.

The I/O map is shown with the following unit configuration as an example.

[Example 1]

	Slot 0	Slot 1	Slot 2	Slot 3	Slot 4	
End plate	DX□B	AXA	DX□D	DY□B	SPL1-X26	Valve
	Digital input	Analog input	Digital input	Digital output	SI unit	

### •Input data

Index	Sub Index	Bit 15 - 8	Bit 7 - 0	Access
2001h	00h	System diagnostic data		RO* <sup>1</sup>
2002h	00h	Unit diagnostic data		RO
2003h	00h	-	DX□B, IN 0 - 7 (Slot 0)	RO
2004h	00h	AXA, analog IN Ch 0 (Slot 1)		RO
2005h	00h	AXA, analog IN Ch 1 (Slot 1)		RO
2006h	00h	DX□D, IN 0 - 15 (Slot 2)		RO
:	:	-		:
2020h	00h			RO

\*1: "RO" means Read Only data.

### •Output data

Index	Sub Index	Bit 15 - 8	Bit 7 - 0	Access
2065h	00h	-	DY□B, OUT 0 - 7 (Slot 3)	RW* <sup>1</sup>
2066h	00h	SPL1-X26, OUT 0 - 15 (Slot4)		RW
2067h	00h	SPL1-X26, OUT 16 - 31 (Slot4)		RW
:	:	-		:
2084h	00h			RW

\*1: "RW" mean that Read and Write are possible.

[Example 2]

	Slot 0	Slot 1	Slot 2	Slot 3	Slot 4	
End plate	AMB	DM□F	DX□F	DY□F	SPL1-X26	Valve
	Analog input /output	Digital input /output	Digital input	Digital output	SI unit	

•Input data

Index	Sub Index	Bit 15 - 8	Bit 7 - 0	Access
2001h	00h	System diagnostic data		RO
2002h	00h	Unit diagnostic data		RO
2003h	00h	AMB, analog IN Ch 0 (Slot 0)		RO
2004h	00h	AMB, analog IN Ch 1 (Slot 0)		RO
2005h	00h	-	DM□F, IN 0 - 7 (Slot 1)	RO
2006h	00h	DX□F, IN 0 - 15 (Slot 2)		RO
:	:	-		:
2020h	00h			RO

•Output data

Index	Sub Index	Bit 15 - 8	Bit 7 - 0	Access
2065h	00h	AMB, analog OUT Ch 2 (Slot 0)		RW
2066h	00h	AMB, analog OUT Ch 3 (Slot 0)		RW
2067h	00h	-	DM□F, OUT 0 - 7 (Slot 1)	RW
2068h	00h	DY□F, OUT 0 - 15 (Slot3)		RW
2069h	00h	SPL1-X26, OUT 0 - 15 (Slot4)		RW
206Ah	00h	SPL1-X26, OUT 16 - 31 (Slot4)		RW
:	:	-		:
2084h	00h			RW

## ■Details of diagnostic data

### • System diagnostic data

Bit No.	Content of diagnosis
0	The analog value has fallen below the user set value.
1	The analog value has exceeded the user set value.
2	The analog input value has fallen below the set range.
3	The analog input value has exceeded the set range.
4	Reserved
5	The open circuit has been detected.
6	The short circuit of the valve output or digital output has been detected.
7	The short circuit of the power supply for the input/output device has been detected.
8	The power supply voltage for output device is outside of the specification.
9	The power supply voltage for control and input device is outside of the specification.
10	Reserved
11	There is a connection failure between each unit (During operation) .
12	There is a connection failure between each unit (When the power supply is applied) .
13	Reserved
14	System error occurred.
15	Hardware error occurred.

### • Unit diagnostic data

Bit No.	Content of diagnosis
0	There is an error in unit 0.
1	There is an error in unit 1.
2	There is an error in unit 2.
3	There is an error in unit 3.
4	There is an error in unit 4.
5	There is an error in unit 5.
6	There is an error in unit 6.
7	There is an error in unit 7.
8	There is an error in unit 8.
9	There is an error in unit 9.
10	Reserved
11	Reserved
12	Reserved
13	Reserved
14	Reserved
15	Reserved

## EX600 Parameter list

The product has parameters that can be set for system, each unit or each channel.  
The parameters can be changed using manufacture specific Objects.

### 1. System Parameter

No.	Parameter	Definition	Item	Content	Default setting* <sup>1</sup>
1	Monitor 24V_C	Generated error per unit when control and input power supply voltage goes over approx. 28 V or under 21 V.	1: True	Generates an error.	○
			0: False	Does not generate an error.	
2	Monitor 24V_D	Generated error per unit when output power supply voltage goes over approx. 28 V or under 20 V.	1: True	Generates an error.	○
			0: False	Does not generate an error.	
3	Hold / Clear	Switch the setting of the output during communication error to follow the setting of the SI unit switch or the parameters.	1: True (Via Software)	Setting by the Manufacture specific object becomes valid. OFF/Hold/Forced ON can be set per channel.	○
			0: False (Via Switch)	Setting by SI unit switch becomes valid.	

\*1: "Default setting" means the parameter setting value of the factory shipment.

### 2. SI Unit

(Unit parameter)

No.	Parameter	Definition	Item	Content	Default setting
1	Monitor Short Circuit	Generates error per unit when the short circuit of the valve is detected.	1: True	Generates an error.	○
			0: False	Does not generate an error.	
2	Restart After Short Circuit	Restore the setting of short circuit detection error per unit after the valve short circuit is cleared.	1: True (Auto)	Error is automatically cleared when the short circuit is fixed.	○
			0: False (Manual)	Even when the short circuit is fixed, error is not cleared until the power is supplied again.	

(Channel parameter)

No.	Parameter	Definition	Item	Content	Default setting
3	Monitor Open Circuit	Generates error per channel when the disconnection of the valve is detected.	1: True	Generates an error.	○
			0: False	Does not generate an error.	
4	Fault Mode Digital*1	Set output per channel when communication error is occurred.	0: Clear	Turn off the output	○
			1: ForcedON	Turn on the output forcefully	
			2: Hold	Hold the output	

\*1: This function is valid only when "Hold/Clear Setting" of the SI Unit parameter is set to "Via software".

### 3. Digital Input Unit

( Unit parameter)

No.	Parameter	Definition	Item	Content	Default setting
1	Monitor Short Circuit	Generates error per unit when the short circuit of the power supply for the input device is detected.	1: True	Generates an error.	○
			0: False	Does not generate an error.	
2	Inrush Current Filter	Ignores excess current per unit for 100 msec. after inrush.	1: True	Ignores excess current.	○
			0: False	Does not ignore excess current.	
3	Digital Input Filtering Time	Sets the time to ignore the input signal change per unit.	0: 0.1 ms	Selects the time for filtering.	1.0 ms
			1: 1.0 ms		
			2: 10 ms		
			3: 20 ms		
4	Digital Input Extension Time	Sets the time to hold the input signal per unit.	0: 1.0ms	Selects the time to hold the input signal.	15 ms
			1: 15 ms		
			2: 100 ms		
			3: 200 ms		

(Channel parameter)

No.	Parameter	Definition	Item	Content	Default setting
5	Monitor Open Circuit	Generates error per channel when the disconnection of the input device is detected.	1: True	Generates an error.	○
			0: False	Does not generate an error.	

Note1) Monitor Open Circuit is a function only available for Digital unit (EX600-DXPC1, EX600-DXNC1) with disconnection detection.

Note 2) 2-wire type input equipment cannot be correctly detected if its leakage current is 0.5 mA or less while the equipment is in the OFF state (reed sensor, etc.)

Ensure that all input equipment used has a leakage current above 0.5 mA in the OFF state.

3-wire type input equipment cannot be correctly detected if its current consumption is 0.5mA or less.

The open circuit of input signals cannot be detected.

#### 4. Digital Output unit

##### (Unit parameter)

No.	Parameter	Definition	Item	Content	Default setting
1	Monitor Short Circuit	Generates error per unit when the short circuit of the output device is detected.	1: True	Generates an error.	○
			0: False	Does not generate an error.	
2	Restart After Short Circuit	Restore the setting of short circuit detection error per unit after the output device short circuit is cleared.	1: True (Auto)	Error is automatically cleared when the short circuit is fixed.	○
			0: False (Manual)	Even when the short circuit is fixed, error is not cleared until the power is supplied again.	

##### (Channel parameter)

No.	Parameter	Definition	Item	Content	Default setting
3	Monitor Open Circuit	Generates error per channel when the disconnection of the output device is detected.	1: True	Generates an error.	○
			0: False	Does not generate an error.	
4	Fault Mode Digital *1	Set output per channel when communication error is occurred.	0: Clear	Turn off the output	○
			1: ForcedON	Turn on the output forcefully	
			2: Hold	Hold the output	

\*1: This function is valid only when "Hold/Clear Setting" of the SI Unit parameter is set to "Via software".

## 5. Digital I/O Unit

( Unit parameter)

No.	Parameter	Definition	Item	Content	Default setting
1	Monitor Short Circuit	Generates error per unit when the short circuit is detected.	1: True	Generates an error.	○
			0: False	Does not generate an error.	
2	Inrush Current Filter	Ignores excess current per unit for 100 msec. after inrush.	1: True	Ignores excess current.	
			0: False	Does not ignore excess current.	○
3	Digital Input Filtering Time	Sets the time to ignore the input signal change per unit.	0: 0.1 ms	Selects the time for filtering.	1.0 ms
			1: 1.0 ms		
			2: 10 ms		
			3: 20 ms		
4	Digital Input Extension Time	Sets the time to hold the input signal per unit.	0: 1.0ms	Selects the time to hold the input signal.	15 ms
			1: 15 ms		
			2: 100 ms		
			3: 200 ms		
5	Restart After Short Circuit	Restore the setting of short circuit detection error per unit after the output device short circuit is cleared.	1: True (Auto)	Error is automatically cleared when the short circuit is fixed.	○
			0: False (Manual)	Even when the short circuit is fixed, error is not cleared until the power is supplied again.	

(Channel parameter)

No.	Parameter	Definition	Item	Content	Default setting
6	Monitor Open Circuit	Generates error per channel when the disconnection of the output device is detected.	1: True	Generates an error.	
			0: False	Does not generate an error.	○
7	Fault Mode Digital*1	Set output per channel when communication error is occurred.*1	0: Clear	Turn off the output	○
			1: ForcedON	Turn on the output forcefully	
			2: Hold	Hold the output	

\*1: This function is valid only when "Hold/Clear Setting" of the SI Unit parameter is set to "Via software".



## 6. Analog Input Unit

( Unit parameter)

No.	Parameter	Definition	Item	Content	Default setting
1	Monitor Short Circuit	Generates error per unit when the short circuit of the power supply for the input device is detected.	1: True	Generates an error.	○
			0: False	Does not generate an error.	
2	Analog Data Format	Sets analog data type which is output to PLC per unit.	0: Offset binary	Offset binary.	○
			1: Sign & Magnitude	Signed binary.	
			2: 2s complement	2's complement.	
3	Monitor Over Range	Generates error per unit when the input value has exceeded the "Range upper limit +0.5% of full span"	1: True	Generates an error.	○
			0: False	Does not generate an error.	
4	Monitor Under Range	Generates error per unit when the input value is below the "Range lower limit -0.5% of full span"	1: True	Generates an error.	○
			0: False	Does not generate an error.	

( Channel parameter)

No.	Parameter	Definition	Item	Content	Default setting
5	Analog Range	Set the analog input range per channel.	0: -10..10 V	Selects the analog input range.	0..10 V
			1: -5..5 V		
			2: -20..20 mA		
			3: 0..10 V		
			4: 0..5 V		
			5: 1..5 V		
			6: 0..20 mA		
7: 4..20 mA					
6	Analog Filter	Sets analog input filtering time per channel. Sampling interval is approx.2ms.	0: None	None	
			1: 2AVG	2 value average	○
			2: 4AVG	4 value average	
3: 8AVG	8 value average				
7	Monitor Upper Limit	Generates error per unit when the input value exceeds the set value.	1: True	Generates an error. *1	
			0: False	Does not generate an error.	○
8	Upper Limit Value*1		Value (-32767.. 32767 )	Value x 0.01 (mA or V)	1000
9	Monitor Lower Limit	Generates error per channel when the input value falls below the set value.	1: True	Generates an error. *1	
			0: False	Does not generate an error.	○
10	Lower Limit Value*1		Value (-32767.. 32767 )	Value x 0.01 (mA or V)	0

\*1: Set value shall be set per analog input range within settable range in the table below.

When the analog input range is changed, check the set value and change it to an appropriate value.

Analog input measurement range	Lower limit		Upper limit	
	Settable value range	Setting Value	Settable value range	Setting Value
-10..10 V	-10.50 to +10.45 V	-1050 to 1045	-10.45 to +10.50 V	-1045 to 1050
-5..5 V	- 5.25 to + 5.22 V	-525 to 522	- 5.22 to +5.25 V	-522 to 525
-20..20 mA	-21.00 to +20.90 mA	-2100 to 2090	-20.90 to +21.00 mA	-2090 to 2100
0..10 V	0.00 to +10.45 V	0 to 1045	+0.05 to +10.50 V	5 to 1050
0..5 V	0.00 to +5.22 V	0 to 522	+0.03 to +5.25 V	3 to 525
1..5 V	+0.75 to +5.22 V	75 to 522	+0.78 to +5.25 V	78 to 525
0..20 mA	0.00 to +20.90 mA	0 to 2090	+0.10 to +21.00 mA	10 to 2100
4..20 mA	+3.00 to +20.90 mA	300 to 2090	+3.10 to +21.00 mA	310 to 2100

## 7. Analog Output Unit

( Unit parameter)

No.	Parameter	Definition	Item	Content	Default setting
1	Monitor Short Circuit	Generates error per unit when the short circuit of the output device is detected.	1: True	Generates an error.	○
			0: False	Does not generate an error.	
2	Analog Data Format	Set analog data type.	0: Offset binary	Offset binary.	○
			1: Sign & Magnitude	Signed binary.	
			2: 2s complement	2's complement.	
			3: Linear Scaled	Linear Scaled	

( Channel parameter)

No.	Parameter	Definition	Item	Content	Default setting
3	Analog Range	Sets the range of the analog output device per channel.	3: 0..10 V	Selects the analog output range.	0..10 V
			4: 0.5 V		
			5: 1..5 V		
			6: 0..20 mA		
			7: 4..20 mA		
4	Monitor Upper Limit	Generates error per channel when the output value is exceed the upper limit value.	1: True	Generates an error. *1	
			0: False	Does not generate an error.	○
5	Upper Limit Value*1	When analog data format is not linear scaled: Set the upper limit value.	Value (-32767..32767 )	Value x 0.01 (mA or V)	1000
		When analog data format is linear scaled: Set the scaled upper limit AD value.		Upper limit AD value of Analog Range.	
6	Monitor Lower Limit	Generates error per channel when the output value is below the lower limit value.	1: True	Generates an error. *1	
			0: False	Does not generate an error.	○
7	Lower Limit Value*1	When analog data format is not linear scaled: Set the user set lower limit value.	Value (-32767..32767 )	Value x 0.01 (mA or V)	0
		When analog data format is linear scaled: Set the scaled upper limit AD value.		Lower limit AD value of Analog Range.	

\*1: Set value shall be set per analog output range within settable range in the table below.

When the analog output range is changed, check the set value and change it to an appropriate value.

No.	Parameter	Definition	Item	Content	Default setting
8	Fault Mode Analog		1: True	Output will be fault value.	
			0: False	Output will be held last state.	○
9	Fault Value Analog <sup>*2</sup>	Set output per channel when communication error is occurred.	Value (-32767.. 32767)	When analog data format is not linear scaled: Value x 0.01 (mA or V) When analog data format is linear scaled: Setting AD value	0

\*2: This function is valid only when "Hold/Clear Setting" of the SI Unit parameter is set to "Via software".

Analog output measurement range	Lower limit		Upper limit	
	Settable value range	Setting Value	Settable value range	Setting Value
0..10 V	0.00 to +10.45 V	0 to 1045	+0.05 to +10.50 V	5 to 1050
0..5 V	0.00 to +5.22 V	0 to 522	+0.03 to +5.25 V	3 to 525
1..5 V	+0.75 to +5.22 V	75 to 522	+0.78 to +5.25 V	78 to 525
0..20 mA	0.00 to +20.90 mA	0 to 2090	+0.10 to +21.00 mA	10 to 2100
4..20 mA	+3.00 to +20.90 mA	300 to 2090	+3.10 to +21.00 mA	310 to 2100

## 8. Analog I/O Unit

( Unit parameter)

No.	Parameter	Definition	Item	Content	Default setting
1	Monitor Short Circuit	Generates error per unit when the short circuit is detected.	True	Generates an error.	○
			False	Does not generate an error.	
2	Analog Data Format	Set analog data type.	0: Offset binary	Offset binary.	○
			1: Sign & Magnitude	Signed binary.	
			2: 2s complement	2's complement.	
			3: Linear Scaled	Linear Scaled	
3	Monitor Over Range	Generates error per unit when the input value has exceeded the "Range upper limit +0.5% of full span"	True	Generates an error.	
			False	Does not generate an error.	○
4	Monitor Under Range	Generates error per unit when the input value is below the "Range lower limit -0.5% of full span"	True	Generates an error.	
			False	Does not generate an error.	○

(Channel parameter)

No.	Parameter	Definition	Item	Content	Default setting
5	Analog Range	Sets the analog input or output range per channel.	3: 0..10 V	Selects the analog input or output range	0..10 V
			4: 0..5 V		
			5: 1.5 V		
			6: 0..20 mA		
			7: 4..20 mA		
6	Analog Filter	Sets analog input filtering time per channel. Sampling interval is approx. 4ms.	0: None	None	
			1: 2AVG	2 value average	○
			2: 4AVG	4 value average	
			3: 8AVG	8 value average	
7	Monitor Upper Limit	Generates error per channel when the input or output value is exceed the upper limit value.	True	Generates an error. *1	
			False	Does not generate an error.	○
8	Upper Limit Value*1	When analog data format is not linear scaled: Set the upper limit value.	Value (-32767.. 32767 )	Value x 0.01 (mA or V)	1000
		When analog data format is linear scaled: Set the scaled upper limit AD value.		Upper limit AD value of Analog Range.	
9	Monitor Lower Limit	Generates error per channel when the input or output value is below the lower limit value.	True	Generates an error. *1	
			False	Does not generate an error.	○
10	Lower Limit Value*1	When analog data format is not linear scaled: Set the user set lower limit value.	Value (-32767.. 32767 )	Value x 0.01 (mA or V)	0
				Lower limit AD value of Analog Range.	
11	Fault Mode Analog	Set output per channel when communication error is occurred.	True	Output will be fault value.	
			False	Output will be held last state.	○
12	Fault Value Analog*2	Set output per channel when communication error is occurred.	Value (-32767.. 32767 )	When analog data format is not linear scaled: Value x 0.01 (mA or V)	0
				When analog data format is linear scaled: Setting AD value	

\*1: Set value shall be set per analog input or output range within settable range in the table below.

When the analog input and output range is changed, check the set value and change it to an appropriate value.

\*2: This function is valid only when "Hold/Clear Setting" of the SI Unit parameter is set to "Via software".

Analog input /output measurement range	Lower limit		Upper limit	
	Settable value range	Setting Value	Settable value range	Setting Value
0..10 V	0.00 to +10.45 V	0 to 1045	+0.05 to +10.50 V	5 to 1050
0.5 V	0.00 to +5.22 V	0 to 522	+0.03 to +5.25 V	3 to 525
1.5 V	+0.75 to +5.22 V	75 to 522	+0.78 to +5.25 V	78 to 525
0..20 mA	0.00 to +20.90 mA	0 to 2090	+0.10 to +21.00 mA	10 to 2100
4..20 mA	+3.00 to +20.90 mA	300 to 2090	+3.10 to +21.00 mA	310 to 2100

# Parameter setting via Manufacture specific Object

The EX600 parameters can be set using manufacture specific object. The image below shows B&R's Automation studio.

All slots (Slot 0~Slot 9) are shown in the parameter settings screen, regardless of the number of connected I/O units to the EX600. All EX600 parameter types will be displayed for each slot. When changing unit parameters, confirm the Slot No. and parameters for the unit before completing settings.

1) Select "EX600-SPL1-X26" from the Physical View, right click and select "Open I/O Configuration".

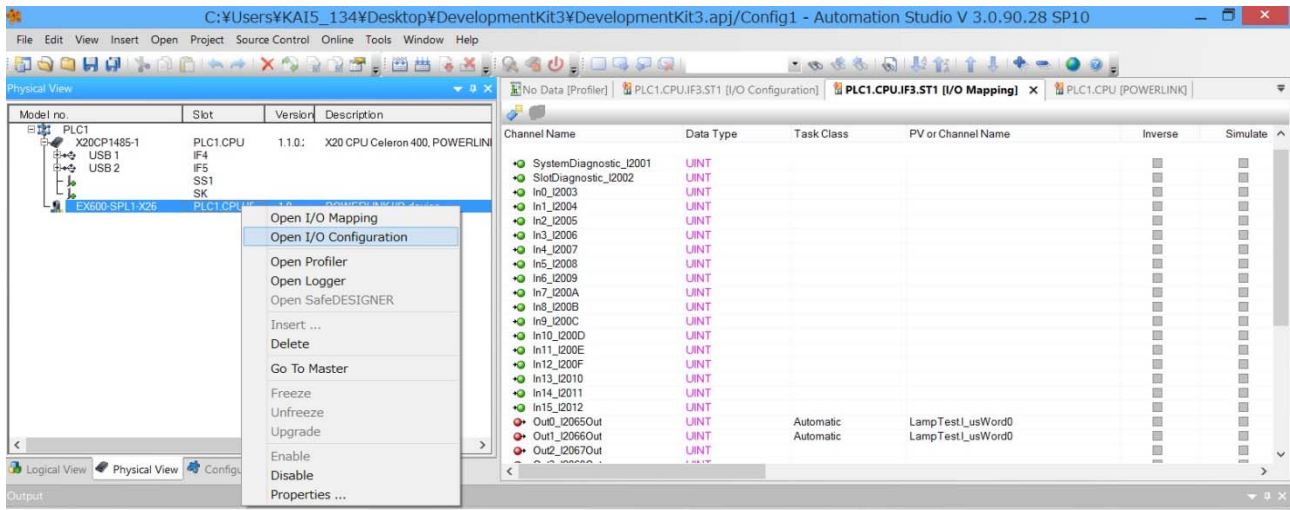

2) The system parameters and slot 0~slot 9 will be displayed in the "Device specific parameters" folder. Parameter allocation for SI units and all I/O units will be shown for each slot.

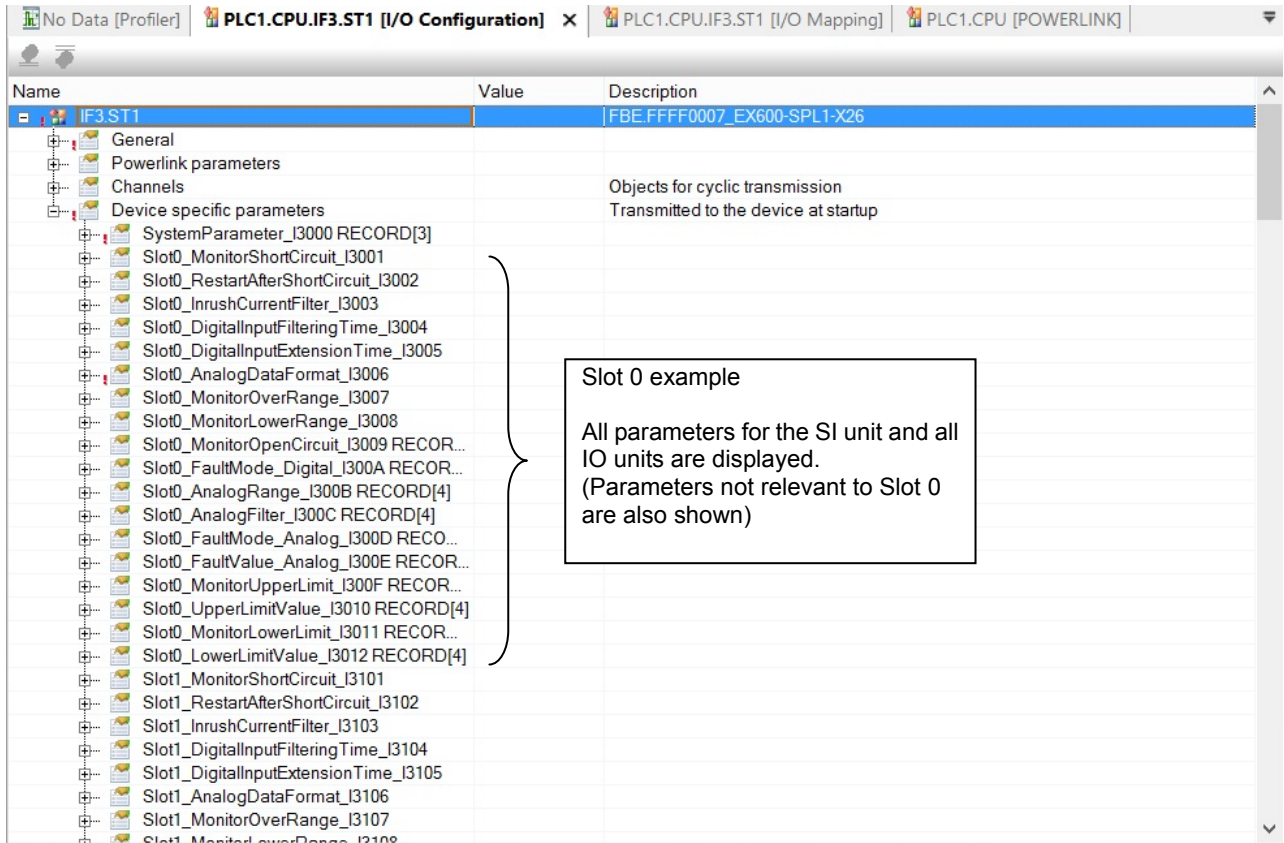

(E.g.) When an analog output unit or analog input unit is connected to Slot 0, and channel 0 needs to be changed to analog range 4-20mA.

3) Select Channel0 (Sub Index 01) from the Slot \_AnalogRange (Index 300B) folder. The default Init value is "3 (0 -10V)".

Name	Value	Description
IF3.ST1		FBE.FFFF0007_EX600-SPL1-X26
General		
Powerlink parameters		
Channels		Objects for cyclic transmission
Device specific parameters		Transmitted to the device at startup
SystemParameter_I3000 RECORD[3]		
Slot0_MonitorShortCircuit_I3001		
Slot0_RestartAfterShortCircuit_I3002		
Slot0_InrushCurrentFilter_I3003		
Slot0_DigitalInputFilteringTime_I3004		
Slot0_DigitalInputExtensionTime_I3005		
Slot0_AnalogDataFormat_I3006		
Slot0_MonitorOverRange_I3007		
Slot0_MonitorLowerRange_I3008		
Slot0_MonitorOpenCircuit_I3009 RECORD...		
Slot0_FaultMode_Digital_I300A RECORD...		
Slot0_AnalogRange_I300B RECORD[4]		
Channel0_I300B_S01		
Datatype	USINT	UNSIGNED8
Init value	3	Set at bootup (clear to preserve value on device)
Channel1_I300B_S02		
Channel2_I300B_S03		
Channel3_I300B_S04		
Slot0_AnalogFilter_I300C RECORD[4]		
Slot0_FaultMode_Analog_I300D RECO...		
Slot0_FaultValue_Analog_I300E RECOR...		
Slot0_MonitorUpperLimit_I300F RECOR...		
Slot0_UpperLimitValue_I3010 RECORD[4]		
Slot0_MonitorLowerLimit_I3011 RECOR...		
Slot0_LowerLimitValue_I3012 RECORD[4]		

4) Change Init value from "3" to "7 (4-20mA)".

Slot0_FaultMode_Digital_I300A RECOR...		
Slot0_AnalogRange_I300B RECORD[4]		
Channel0_I300B_S01		
Datatype	USINT	UNSIGNED8
Init value	7	Set at bootup (clear to preserve value on device)
Channel1_I300B_S02		
Channel2_I300B_S03		
Channel3_I300B_S04		
Slot0_AnalogFilter_I300C RECORD[4]		
Slot0_FaultMode_Analog_I300D RECO...		
Slot0_FaultValue_Analog_I300E RECOR...		



5) Click the “transfer” button to download the altered parameters to the EX600.

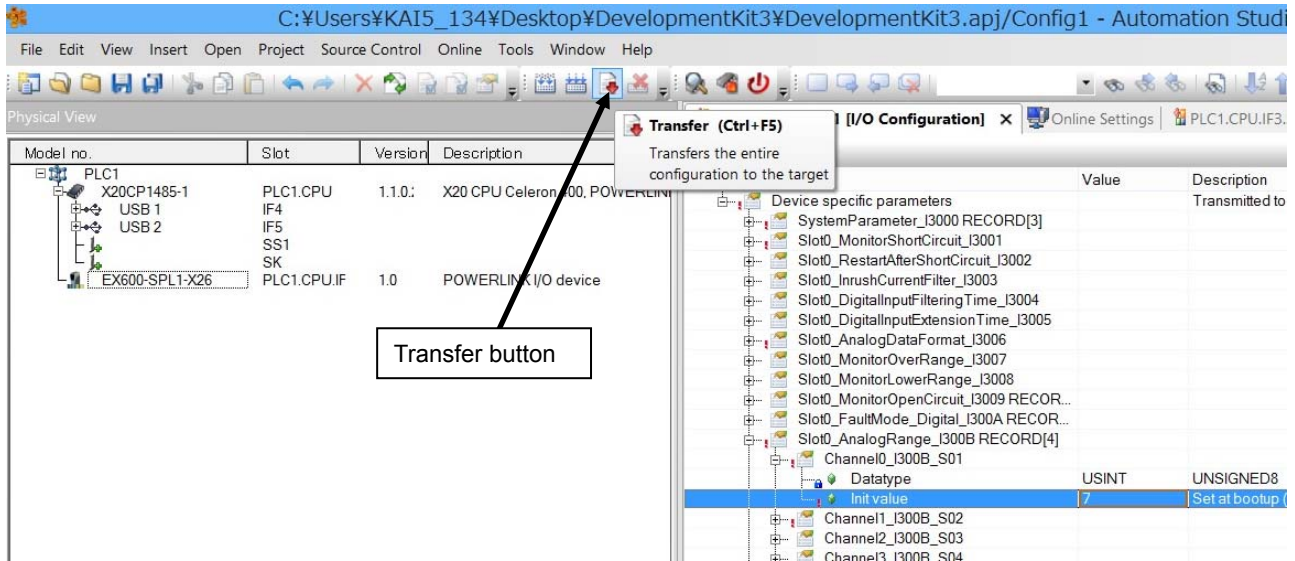

6) Start parameter download. The box below will be displayed while parameters are being transferred.

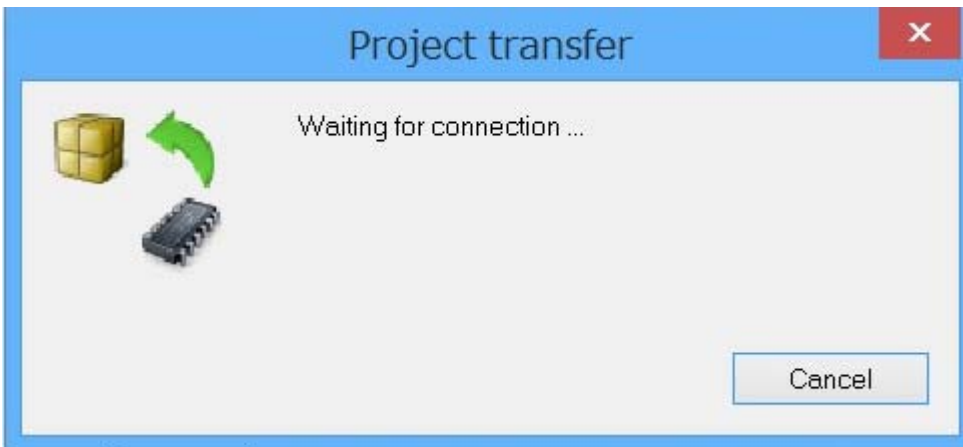

7) The box below will be displayed after the parameter download is complete. Click “OK”.

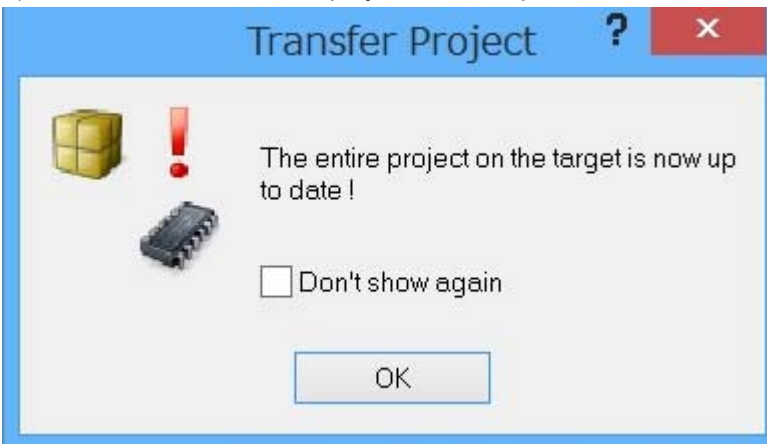

## Manufacture specific Object

Index	Object Name	Sub Index	Description	Value/Notes
3000h	SystemParameter	00h	NumberOfEntries	3
		01h	Monito24V_C	0: false (default)
		02h	Monito24V_D	0:false (default)
		03h	Hold Clear	0:false, Switch (default) , 1: true, Parameter setting
3001h	Slot0_MonitorShortCircuit	00h		1: true (default)
3002h	Slot0_RestartAfterShortCircuit	00h		1: true (default)
3003h	Slot0_InrushCurrentFilter	00h		0: false (default)
3004h	Slot0_DigitalInputFilteringTime	00h		0: 0.1ms, 1: 1ms (default) , 2: 10ms, 3: 20ms
3005h	Slot0_DigitalInputExtensionTime	00h		0: 1ms, 1: 15ms (default) , 2: 100ms, 3: 200ms
3006h	Slot0_AnalogDataFormat	00h		0: Offset (default) , 1: Signed, 2: 2's, 3: Scaled
3007h	Slot0_MonitorOverRange	00h		0: false (default)
3008h	Slot0_MonitorUnderRange	00h		0: false (default)
3009h	Slot0_MonitorOpenCircuit	00h	NumberOfEntries	32
		01h	Channel 0	0: false (default)
		..	..	..
		20h	Channel 31	0: false (default)
300Ah	Slot0_FaultMode_Digital	00h	NumberOfEntries	32
		01h	Channel 0	0: Clear (default) , 1: Forced On, 2: Hold
		..	..	..
		20h	Channel 31	0: Clear (default) , 1: Forced On, 2: Hold
300Bh	Slot0_AnalogRange	00h	NumberOfEntries	4
		01h	Channel 0	0: -10..+10V, 1: -5..+5V, 2: -20..+20mA, 3: 0..10V (default) , 4: 0..5V, 5: 1..5V, 6: 0..20mA, 7: 4..20mA
		..	..	..
		04h	Channel 3	0: -10..+10V, 1: -5..+5V, 2: -20..+20mA, 3: 0..10V (default) , 4: 0..5V, 5: 1..5V, 6: 0..20mA, 7: 4..20mA
300Ch	Slot0_AnalogFilter	00h	NumberOfEntries	4
		01h	Channel 0	0: None, 1: 2 value (default) , 2: 4 value, 3: 8 value
		..	..	..
		04h	Channel 3	0: None, 1: 2 value (default) , 2: 4 value, 3: 8 value
300Dh	Slot0_FaultMode_Analog	00h	NumberOfEntries	4
		01h	Channel 0	0: false (default)
		..	..	..
		04h	Channel 3	0: false (default)
300Eh	Slot0_FaultValue_Analog	00h	NumberOfEntries	4
		01h	Channel 0	-32767..32767 (default: 0)
		..	..	..
		04h	Channel 3	-32767..32767 (default: 0)
300Fh	Slot0_MonitorUpperLimit	00h	NumberOfEntries	4
		01h	Channel 0	0: false (default)
		..	..	..
		04h	Channel 3	0: false (default)

Index	Object Name	Sub Index	Description	Value/Notes
3010h	Slot0_UpperLimitValue	00h	NumberOfEntries	4
		01h	Channel 0	-32767..32767 (default: 1000)
		..	..	..
		04h	Channel 3	-32767..32767 (default: 1000)
3011h	Slot0_MonitorLowerLimit	00h	NumberOfEntries	4
		01h	Channel 0	0: false (default)
		..	..	..
		04h	Channel 3	0: false (default)
3012h	Slot0_LowerLimitValue	00h	NumberOfEntries	4
		01h	Channel 0	-32767..32767 (default: 0)
		..	..	..
		04h	Channel 3	-32767..32767 (default: 0)
..	..	..	..	..
3901h	Slot9_MonitorShortCircuit	00h		1: true (default)
3902h	Slot9_RestartAfterShortCircuit	00h		1: true (default)
3903h	Slot9_InrushCurrentFilter	00h		0: false (default)
3904h	Slot9_DigitalInputFilteringTime	00h		0: 0.1ms, 1: 1ms (default), 2: 10ms, 3: 20ms
3905h	Slot9_DigitalInputExtensionTime	00h		0: 1ms, 1: 15ms (default), 2: 100ms, 3: 200ms
3906h	Slot9_AnalogDataFormat	00h		0: Offset (default), 1: Signed, 2: 2's, 3: Scaled
3907h	Slot9_MonitorOverRange	00h		0: false (default)
3908h	Slot9_MonitorUnderRange	00h		0: false (default)
3909h	Slot9_MonitorOpenCircuit	00h	NumberOfEntries	32
		01h	Channel 0	0: false (default)
		..	..	..
		20h	Channel 31	0: false (default)
390Ah	Slot9_FaultMode_Digital	00h	NumberOfEntries	32
		01h	Channel 0	0: Clear (default), 1: ForcedOn, 2: Hold
		..	..	..
		20h	Channel 31	0: Clear (default), 1: ForcedOn, 2: Hold
390Bh	Slot9_AnalogRange	00h	NumberOfEntries	4
		01h	Channel 0	0: -10..+10V, 1: -5..+5V, 2: -20..+20mA, 3: 0..10V (default), 4: 0..5V, 5: 1..5V, 6: 0..20mA, 7: 4..20mA
		..	..	..
		04h	Channel 3	0: -10..+10V, 1: -5..+5V, 2: -20..+20mA, 3: 0..10V (default), 4: 0..5V, 5: 1..5V, 6: 0..20mA, 7: 4..20mA

Index	Object Name	Sub Index	Description	Value/Notes
390Ch	Slot9_AnalogFilter	00h	NumberOfEntries	4
		01h	Channel 0	0: None, 1: 2 value (default) , 2: 4 value, 3: 8 value,
		..	..	..
		04h	Channel 3	0: None, 1: 2 value (default) , 2: 4 value, 3: 8 value,
390Dh	Slot9_FaultMode_Analog	00h	NumberOfEntries	4
		01h	Channel 0	0: false (default)
		..	..	..
		04h	Channel 3	0: false (default)
390Eh	Slot9_FaultValue_Analog	00h	NumberOfEntries	4
		01h	Channel 0	-32767..32767 (default: 0)
		..	..	..
		04h	Channel 3	-32767..32767 (default: 0)
390Fh	Slot9_MonitorUpperLimit	00h	NumberOfEntries	4
		01h	Channel 0	0:false (default)
		..	..	..
		04h	Channel 3	0:false (default)
3910h	Slot9_UpperLimitValue	00h	NumberOfEntries	4
		01h	Channel 0	-32767..32767 (default: 1000)
		..	..	..
		04h	Channel 3	-32767..32767 (default: 1000)
3911h	Slot9_MonitorLowerLimit	00h	NumberOfEntries	4
		01h	Channel 0	0:false (default)
		..	..	..
		04h	Channel 3	0:false (default)
3912h	Slot9_LowerLimitValue	00h	NumberOfEntries	4
		01h	Channel 0	-32767..32767 (default: 0)
		..	..	..
		04h	Channel 3	-32767..32767 (default: 0)

## Accessories

For the selection of accessories, refer to the catalog.

### (1) Valve plate

EX600-ZMV1

Enclosed parts: Round head screw (M4 x 6) , 2 pcs.

Round head screw (M3 x 8) , 4 pcs.

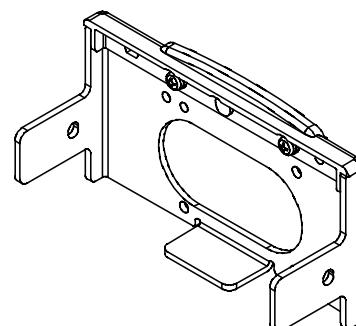

EX600-ZMV2 (Specified for SY series)

Enclosed parts: Round head screw (M4 x 6) , 2 pcs.

Round head screw (M3 x 8) , 4 pcs.

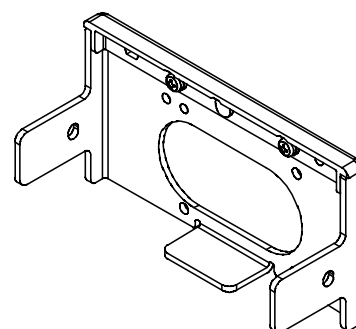

### (2) End plate bracket

EX600-ZMA2

Enclosed parts: Round head screw (M4 x 20) , 1 pc.

P tight screw (4 x 14) , 2 pcs.

EX600-ZMA3 (Specified for SY series)

Enclosed parts: Round head screw (M4 x 20) with washer, 1 pc.

P tight screw (4 x 14) , 2 pcs.

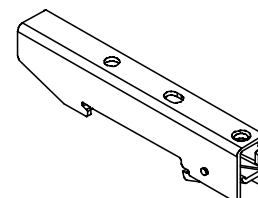

### (3) Intermediate support bracket

EX600-ZMB1...for direct mounting

Enclosed parts: Round head screw (M4 x 5) , 2 pcs.

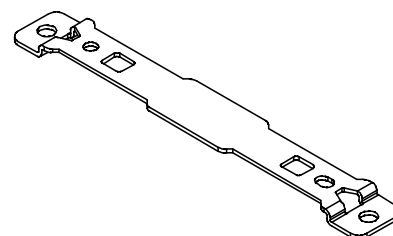

EX600-ZMB2...for DIN rail mounting

Enclosed parts: Round head screw (M4 x 6) , 2 pcs.

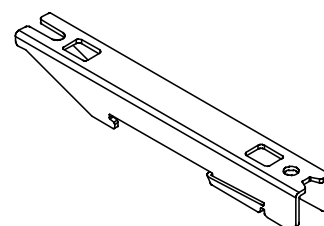

(4) Seal cap (10 pcs.)

EX9-AWES...for M8

EX9-AWTS...for M12

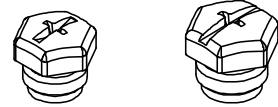

(5) Marker (1 sheet, 88 pcs.)

EX600-ZT1

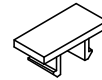

(6) Assembled type connector

PCA-1446553: For EtherNet/IP™ communication, M12 (4 pin) Plug, D code

PCA-1578078: For power supply, 7/8 inch, Plug, Cable O.D. 12 to 14 mm

PCA-1578081: For power supply, 7/8 inch, Socket, Cable O.D. 12 to 14 mm

(7) Power supply cable

PCA-1558810: Cable with 7/8 inch connector, Socket, Straight 2 m

PCA-1558823: Cable with 7/8 inch connector, Socket, Straight 6 m

PCA-1558836: Cable with 7/8 inch connector, Socket, Right angle 2 m

PCA-1558849: Cable with 7/8 inch connector, Socket, Right angle 6 m

PCA-1564927: Cable with M12 connector, B code, Socket, Straight 2 m, SPEEDCON compatible

PCA-1564930: Cable with M12 connector, B code, Socket, Straight 6 m, SPEEDCON compatible

PCA-1564943: Cable with M12 connector, B code, Socket, Right angle 2 m, SPEEDCON compatible

PCA-1564969: Cable with M12 connector, B code, Socket, Right angle 6 m, SPEEDCON compatible

(8) Ethernet communication cable

PCA-1446566: Cable with M12 connector, D code, Plug, Straight 5 m, SPEEDCON compatible

EX9-AC010EN-PSRJ: Cable with M12 connector, D code-RJ45, Plug, Straight 1 m

EX9-AC020EN-PSRJ: Cable with M12 connector, D code-RJ45, Plug, Straight 2 m

EX9-AC030EN-PSRJ: Cable with M12 connector, D code-RJ45, Plug, Straight 3 m

EX9-AC050EN-PSRJ: Cable with M12 connector, D code-RJ45, Plug, Straight 5 m

EX9-AC100EN-PSRJ: Cable with M12 connector, D code-RJ45, Plug, Straight 10 m

Revision history

## SMC Corporation

4-14-1, Sotokanda, Chiyoda-ku, Tokyo 101-0021 JAPAN

Tel: +81 3 5207 8249 Fax: +81 3 5298 5362

URL <http://www.smcworld.com>

---

Note: Specifications are subject to change without prior notice and any obligation on the part of the manufacturer.

The descriptions of products shown in this document may be used by the other companies as their trademarks.

© 2015 SMC Corporation All Rights Reserved