



Operation Manual

PRODUCT NAME

AIR OPERATED VALVE
SUCK BACK VALVE

MODEL / Series / Product Number

LVA/LVC Series

SMC Corporation

Contents

1. Safety Instructions P1
2. Precautions P2~4
3. LVC Series How to Order and Specifications P5~6
4. LVC Series(Suck Back) How to Order and Specifications P7
5. LVA Series How to Order and Specifications P8~9
6. Organic Solvents compatible P10
7. Applicable Fluids P11
8. Fittings and Special Tools P12
9. Failure and countermeasures P13

Safety Instructions

These safety instructions are intended to prevent hazardous situations and/or equipment damage. These instructions indicate the level of potential hazard with the labels of “**Caution**,” “**Warning**” or “**Danger**.” They are all important notes for safety and must be followed in addition to International Standards (ISO/IEC)*1), and other safety regulations.

 **Caution:** Caution indicates a hazard with a low level of risk which, if not avoided, could result in minor or moderate injury.

 **Warning:** Warning indicates a hazard with a medium level of risk which, if not avoided, could result in death or serious injury.

 **Danger:** Danger indicates a hazard with a high level of risk which, if not avoided, will result in death or serious injury.

*1) ISO 4414: Pneumatic fluid power – General rules relating to systems.
 ISO 4413: Hydraulic fluid power – General rules relating to systems.
 IEC 60204-1: Safety of machinery – Electrical equipment of machines.
 (Part 1: General requirements)
 ISO 10218-1: Manipulating industrial robots – Safety.
 etc.

Warning

- The compatibility of the product is the responsibility of the person who designs the equipment or decides its specifications.**
 Since the product specified here is used under various operating conditions, its compatibility with specific equipment must be decided by the person who designs the equipment or decides its specifications based on necessary analysis and test results. The expected performance and safety assurance of the equipment will be the responsibility of the person who has determined its compatibility with the product. This person should also continuously review all specifications of the product referring to its latest catalog information, with a view to giving due consideration to any possibility of equipment failure when configuring the equipment.
- Only personnel with appropriate training should operate machinery and equipment.**
 The product specified here may become unsafe if handled incorrectly. The assembly, operation and maintenance of machines or equipment including our products must be performed by an operator who is appropriately trained and experienced.
- Do not service or attempt to remove product and machinery/equipment until safety is confirmed.**
 - The inspection and maintenance of machinery/equipment should only be performed after measures to prevent falling or runaway of the driven objects have been confirmed.
 - When the product is to be removed, confirm that the safety measures as mentioned above are implemented and the power from any appropriate source is cut, and read and understand the specific product precautions of all relevant products carefully.
 - Before machinery/equipment is restarted, take measures to prevent unexpected operation and malfunction.
- Contact SMC beforehand and take special consideration of safety measures if the product is to be used in any of the following conditions.**
 - Conditions and environments outside of the given specifications, or use outdoors or in a place exposed to direct sunlight.
 - Installation on equipment in conjunction with atomic energy, railways, air navigation, space, shipping, vehicles, military, medical treatment, combustion and recreation, or equipment in contact with food and beverages, emergency stop circuits, clutch and brake circuits in press applications, safety equipment or other applications unsuitable for the standard specifications described in the product catalog.
 - An application which could have negative effects on people, property, or animals requiring special safety analysis.
 - Use in an interlock circuit, which requires the provision of double interlock for possible failure by using a mechanical protective function, and periodical checks to confirm proper operation.

Caution

- The product is provided for use in manufacturing industries.**
 The product herein described is basically provided for peaceful use in manufacturing industries.
 If considering using the product in other industries, consult SMC beforehand and exchange specifications or a contract if necessary.
 If anything is unclear, contact your nearest sales branch.

Limited warranty and Disclaimer/ Compliance Requirements

The product used is subject to the following “Limited warranty and Disclaimer” and “Compliance Requirements”.
 Read and accept them before using the product.

Limited warranty and Disclaimer

- The warranty period of the product is 1 year in service or 1.5 years after the product is delivered, whichever is first.*2)
 Also, the product may have specified durability, running distance or replacement parts. Please consult your nearest sales branch.
- For any failure or damage reported within the warranty period which is clearly our responsibility, a replacement product or necessary parts will be provided. This limited warranty applies only to our product independently, and not to any other damage incurred due to the failure of the product.
- Prior to using SMC products, please read and understand the warranty terms and disclaimers noted in the specified catalog for the particular products.

*2) Vacuum pads are excluded from this 1 year warranty.

A vacuum pad is a consumable part, so it is warranted for a year after it is delivered. Also, even within the warranty period, the wear of a product due to the use of the vacuum pad or failure due to the deterioration of rubber material are not covered by the limited warranty.

Compliance Requirements

- The use of SMC products with production equipment for the manufacture of weapons of mass destruction (WMD) or any other weapon is strictly prohibited.
- The exports of SMC products or technology from one country to another are governed by the relevant security laws and regulations of the countries involved in the transaction. Prior to the shipment of a SMC product to another country, assure that all local rules governing that export are known and followed.

Caution

SMC products are not intended for use as instruments for legal metrology.
 Measurement instruments that SMC manufactures or sells have not been qualified by type approval tests relevant to the metrology (measurement) laws of each country. Therefore, SMC products cannot be used for business or certification ordained by the metrology (measurement) laws of each country.

Revision history	
Edition B	* Body class 6, manifold specifications and options added to the LVC and LVA series. * Manifold specifications added to the LVH series. * Number of pages increased from 32 to 44. GR
Edition C	* 3 port added to the LVC and LVA series. * The models with indicator added to the LVC and LVA series. HX
Edition D	* Organic solvents compatible products (LVA/LVH) added. * Symbol changed. * LVC-Z type added. * Number of pages increased from 44 to 56. UR

 **Safety Instructions** Be sure to read the “Handling Precautions for SMC Products” (M-E03-3) and “Operation Manual” before use.



LV□ Series High Purity Chemical Liquid Valve Precautions 1

Be sure to read this before handling the products.
Refer to the back cover for Safety Instructions.

Design / Selection

Warning

1. Check the specifications.

Give careful consideration to operating conditions such as the application, fluid and environment, and use within the operating ranges specified in this catalog.

2. Fluids

Operate after confirming the compatibility of the product's component materials with fluids, using the check list on page 50. Please contact SMC regarding fluids other than those in the check list. Operate within the indicated fluid temperature range.

3. Maintenance space

Ensure the necessary space for maintenance and inspections.

4. Fluid pressure range

Keep the supplied fluid pressure within the operating pressure range shown in the catalog.

5. Ambient environment

Install in an environment where there is no effect from radiant heat caused by heat sources, etc., and use within the ambient temperature range. After confirming the compatibility of the product's component materials with the ambient environment, operate so that fluid does not adhere to the product's exterior surfaces.

6. Liquid seals

When circulating fluid:

Provide a relief valve in the system so that fluid does not get into the liquid seal circuit.

7. Countermeasures for static electricity

Since static electricity may be generated depending on the fluid being used, implement suitable countermeasures.

Mounting

Warning

1. If air leakage increases or equipment does not operate properly, stop operation.

After mounting, perform suitable function and leak tests to confirm that the mounting is correct.

2. Operation Manual

Mount and operate the product after reading the manual carefully and understanding its contents. Also, keep the manual where it can be referred to as necessary.

Piping

Caution

1. Preparation before piping

Before piping is connected, it should be thoroughly flushed out with air or washed to remove chips, cutting oil and other debris from inside the pipe.

Install piping so that it does not apply pulling, pressing, bending or other forces on the valve body.

2. Use the tightening torques shown below for the pilot port.

Tightening Torque for Operating Port

Operating port	Torque [N·m]
M5	1/6 turn with a tightening tool after first tightening by hand
Rc, NPT1/8	0.8 to 1.0

Piping

Caution

3. Use of metal fittings

Do not use metal fittings for piping on taper threads made of resin, as this may cause damage to the threads.

LVA PPS Body Ported Tightening Torque for Fittings

Size	Breaking torque [N·m]	Tightening torque [N·m]	Guideline for tightening torque (Number of turns)
LVA20	2 to 3	0.5 to 1	2 to 3 turns
LVA30	6 to 8	2 to 3	3 to 4 turns
LVA40	11 to 14	5 to 7	3 to 4 turns
LVA50	18 to 20	8 to 10	3 to 4 turns

*: Guideline for tightening torque

Number of turns when the fitting is screwed into the body with 2 to 3 windings of sealant tape applied to threaded portion of the piping. The value may differ for types other than sealant type.

4. Use pilot ports and sensor (breathing) ports as indicated below.

	PA port	PB port	Sensor (breathing) port
N.C.	Pressure	Breathing	Breathing
N.O.	Breathing	Pressure	Breathing
Double acting	Pressure	Pressure	Breathing

For N.C. and N.O. types, the port which does not receive operating pressure is released to atmosphere. When intake and exhaust directly from the valve is not desired due to problems with the ambient environment or scattering of dust, etc., install piping and perform intake and exhaust at a location which does not present a problem.

5. Connect tubing with special tools.

Refer to the catalog "High-Purity Fluoropolymer Fittings Hyper Fittings/LQ1, 2 Series Work Procedure Instructions" (M-E05-1) for connecting tubing and special tools. (Downloadable from the SMC website.)



6. SMC's G threads and thread depths

Body material: Stainless steel [mm]

	P	Q	R
LVA1	G1/8: 6.2	—	—
LVA20	G1/4: 9.4	G1/8: 6.2	—
LVA21/22	—	—	—
LVA3	G1/4: 9.4 G3/8: 9.7	—	—
LVA4	G3/8: 9.7 G1/2: 13	G1/8: 6.2	G1/8: 6.2
LVA5	G1/2: 13 G3/4: 14.5	—	—
LVA6	G1: 16.2	—	—

Body material: PPS [mm]

	P	Q	R
LVA1	G1/8: 6.2	—	—
LVA20	G1/4: 9.4	—	—
LVA21/22	G1/4: 9.4	G1/8: 6.2	—
LVA3	G3/8: 9.7	—	—
LVA4	G1/2: 13	G1/8: 6.2	G1/8: 6.2
LVA5	G3/4: 14.5	—	—

Body material: PFA [mm]

	P	R	U
LVA1	G1/8: 6.2	—	—
LVA20	G1/4: 9.4	G1/8: 6.2	—
LVA21/22	G1/4: 9.4	—	—
LVA3	G3/8: 9.7	—	—
LVA4	G1/2: 13	G1/8: 6.2	G1/8: 6.2
LVA5	G3/4: 14.5	—	—
LVA6	G1: 16.2	—	—



LV□ Series High Purity Chemical Liquid Valve Precautions 2

Be sure to read this before handling the products.
Refer to the back cover for Safety Instructions.

Operating Air Supply

⚠ Warning

1. Use clean air.

Do not use compressed air which includes chemicals, synthetic oils containing organic solvents, salt, or corrosive gases, etc., as this may cause damage or malfunction.

Operating Environment

⚠ Warning

1. Do not use in a location having an explosive atmosphere.
2. Do not operate in locations where vibration or impact occurs.
3. Do not use in locations where radiated heat will be received from nearby heat sources.
4. Do not use in environments which exceed the ambient temperature specifications of the product.

Maintenance

⚠ Warning

1. Maintenance should be performed in accordance with the procedures in the Operation Manual.

Incorrect handling can cause damage or malfunction of machinery and equipment, etc.

2. Before removing equipment or compressed air supply/exhaust devices, shut off the air and power supplies, and exhaust compressed air from the system. Further, when restarting equipment after remounting or replacement, first confirm safety and then check the equipment for normal operation.
3. Perform work after removing residual chemicals and carefully replacing them with DI water (Deionized water) or air, etc.
4. Do not disassemble the product. Products which have been disassembled cannot be guaranteed. If disassembly is necessary, please contact SMC.
5. In order to obtain optimum performance from valves, perform periodic inspections to confirm that there are no leaks from valves or fittings, etc.

⚠ Caution

1. Removal of drainage

Flush drainage from filters regularly.

Handling

⚠ Warning

1. Operate within the ranges of the maximum operating pressure and back pressure.

Handling

⚠ Caution

1. When the diaphragm is made of PTFE

Please note that when the product is shipped from the factory, gases such as N₂ and air may leak from the valve at a rate of 1 cm³/min (when pressurized).

2. When operated at a very low flow rate, the LV□ series with flow rate adjustment may vibrate, etc. depending on the operating conditions. Therefore, operate it after careful examination of the flow rate, pressure and piping conditions.
3. In the LV□ series, water hammering may occur depending on the fluid pressure conditions. In most cases, improvement is possible by adjusting the pilot pressure with a speed controller, etc., but the flow rate, pressure and piping conditions should be reviewed.
4. To adjust the flow rate for the LV□ series with flow rate adjustment, open gradually starting from the fully closed state.

Opening is accomplished by turning the adjustment knob counterclockwise. Additionally, do not apply excessive force to the adjustment knob when nearing a fully open or closed state. This may result in deformation of the orifice sheet surface or damage to the threaded portion of the adjustment knob. It is in the fully closed state when the product is shipped from the factory.

5. After a long period of nonuse, perform a test run before beginning regular operation.
6. Since the LVC is packaged in a clean room, use sufficient care in handling when opened.
7. Take extra care when setting the operating direction and when handling the lever of the LVH series.

Use of Tubing

⚠ Caution

1. Refer to the applicable tubing sizes shown below for tubing to be used.

Applicable Tubing Sizes

	Connecting tubing size	O.D. [mm]		Internal thickness [mm]	
		Standard size	Tolerance	Standard size	Tolerance
Metric size	ø3 x ø2	3.0	+0.2 -0.1	0.5	±0.06 ±0.1 ±0.15
	ø4 x ø3	4.0			
	ø6 x ø4	6.0			
	ø8 x ø6	8.0	+0.3 -0.1	1.0	
	ø10 x ø8	10.0			
	ø12 x ø10	12.0	1.5		
	ø19 x ø16	19.0			
ø25 x ø22	25.0				
Inch size	1/8" x 0.086"	3.18	+0.2 -0.1	0.5	±0.1
	3/16" x 1/8"	4.75		0.8	
	1/4" x 5/32"	6.35		1.2	±0.12
	3/8" x 1/4"	9.53			
	1/2" x 3/8"	12.7	1.6	±0.15	
	3/4" x 5/8"	19.0			
	1" x 7/8"	25.4			+0.3 -0.1



LV□ Series

High Purity Chemical Liquid Valve Precautions 3

Be sure to read this before handling the products.
Refer to the back cover for Safety Instructions.

Return of Product

⚠ Warning

If the product to be returned is contaminated or is possibly contaminated with substances that are harmful to humans, for safety reasons, please contact SMC beforehand and then employ a specialist cleaning company to decontaminate the product. After the decontamination prescribed above has been carried out, submit a Product Return Request Sheet or the Detoxification/Decontamination Certificate to SMC and await SMC's approval and further instructions before attempting to return the item.

Please refer to the International Chemical Safety Cards (ICSC) for a list of harmful substances.

If you have any further questions, please don't hesitate to contact your SMC sales representative.

Air Operated Insert Bushing Integrated Fitting Type **LVC Series**

How to Order Valve (Single Type)

For N.C.

Body class: 2

LVC 2 0 - S 06 [] [] [] [] [] - Z

Pilot port thread type

Symbol	Thread type
Nil	Fc
N	NPT
F	G

For N.O./Double acting

Body class: 2

LVC 2 1 - S 06 [] [] [] [] [] - []

Pilot port thread size 1/8

Symbol	Body class	Orifice dia.	Valve type
2	2	ø4	1 N.O.
			2 Double acting

Body class:
3, 4, 5, 6

LVC 3 0 - S 10 [] [] [] [] [] - V

Specifications

Symbol	None
Nil	None
V	Vacuum specification

Symbol	Body class	Orifice dia.
3	3	ø8
4	4	ø10
5	5	ø16
6	6	ø22

Body class

Option

Symbol	None
1	With flow rate adjustment
2	With bypass
3	With flow rate adjustment & bypass
4	With indicator

*: Applicable to only material symbol Nil.

Valve type	
0	N.C.
1	N.O.
2	Double acting

*: Refer to Variations for valve type combinations.

Port B (OUT) different dia. size

Symbol	Application
Nil	Ports A & B same size
Refer to the applicable tubing table on the left.	Different diameter tubing can be selected within the same body class.

*: Refer to Variations for option combinations. Options cannot be combined.

Pilot port thread type

Symbol	Body class	Thread type
Nil	2	M5
N	3, 4, 5, 6	Rc1/8
F	3, 4, 5, 6	NPT1/8
F	3, 4, 5, 6	G1/8

Material

Symbol	Body	Actuator section	End plate	Diaphragm	Applicable option				Note
					1	2	3	4	
Nil	PFA	PPS	PTFE	●	●	●	●	●	—
F	PFA	PVDF	PTFE	—	—	—	—	—	Hydrofluoric acid compatible (Only LVC40, 50 type)
N	PFA	PPS	PTFE	●	●	●	●	●	Ammonium hydroxide compatible

LQ2 integrated fitting

Applicable tubing size^{*1,2}

Symbol	Connecting tubing size	Body class					
		2	3	4	5	6	
Metric size							
03	3 x 2	●					
04	4 x 3	●					
06	6 x 4	○	●				
08	8 x 6		○	●			
10	10 x 8			○	●		
12	12 x 10				○	●	
19	19 x 16					○	●
25	25 x 22						○
Inch size							
03	1/8" x 0.086"	●					
05	3/16" x 1/8"	●					
07	1/4" x 5/32"	○	●				
11	3/8" x 1/4"		○	●			
13	1/2" x 3/8"			○	●		
19	3/4" x 5/8"				○	●	
25	1" x 7/8"					○	●

○ Basic size ● With reducer

*1: Applicable fitting for body class 6 is LQ1.
*2: Refer to page 52 for details of the applicable tubing sizes.

Variations

Type	Symbol	Valve Type	Model	Orifice diameter					
				LVC20	LVC30	LVC40	LVC50	LVC60	
				ø4	ø8	ø10	ø16	ø22	
Basic	[Diagram]	N.C.	N.C.	○	○	○	○	○	
				Double acting	○	○	○	○	○
With flow rate adjustment	[Diagram]	N.C.	N.C.	○	○	○	○	○	
				Double acting	○	○	○	○	○
With bypass	[Diagram]	N.C.	N.C.	—	○	○	○	—	
				Double acting	—	○	○	○	—
With flow rate adjustment & bypass	[Diagram]	N.C.	N.C.	—	○	○	○	—	
				Double acting	—	○	○	○	—
With indicator	[Diagram]	N.C.	N.C.	○	○	○	○	○	
				Double acting	○	○	○	○	○

Air Operated **LVC Series** Insert Bushing Integrated Fitting Type

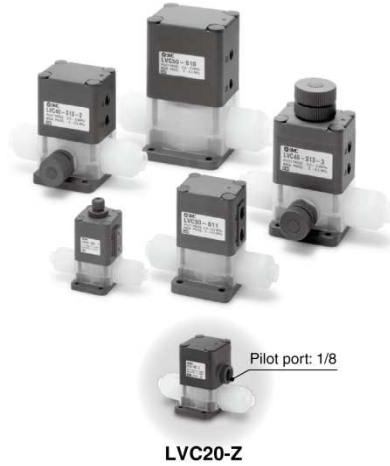

Standard Specifications

Model		LVC20	LVC30	LVC40	LVC50	LVC60
Tubing O.D. *1	Metric size	6	10	12	19	25
	Inch size	1/4	3/8	1/2	3/4	1
Orifice diameter		ø4	ø8	ø10	ø16	ø22
Flow rate characteristics	Kv	0.3	1.4	2.1	5.1	6.8
	Cv	0.35	1.7	2.5	6	8
Withstand pressure [MPa]		1				
Operating pressure [MPa]	A → B	(-94 kPa)*2 0 to 0.5			(-94 kPa)*2 0 to 0.4	
	B → A	(-94 kPa)*2 0 to 0.2			(-94 kPa)*2 0 to 0.1	
Back pressure [MPa]	N.C./N.O.	0.3 or less			0.2 or less	
	Double acting	0.4 or less			0.3 or less	
Valve leakage [cm ³ /min]		0 (with water pressure)				
Pilot air pressure [MPa]		0.3 to 0.5				
Pilot port size	Standard	M5*3	Rc1/8, NPT1/8, G1/8			
	-Z type*4	Rc1/8, NPT1/8, G1/8	—			
Fluid temperature [°C]		0 to 100				
Ambient temperature [°C]		0 to 60				
Weight [kg]		0.09	0.23	0.42	0.86	1.00

- *1: Refer to page 52 for details of the applicable tubing sizes.
 *2: When using for vacuum, select the product number ending in "-V". This product cannot be used for vacuum retention. Also, connecting the vacuum to the B port may reduce the life of the product.
 *3: Applicable for the LVC21 (N.O.) and LVC22 (double acting) types
 *4: Applicable for the LVC20 (N.C.)-Z type
 *: Please contact SMC if the manifold will be used with vacuum and B → A flow.

Different Diameter Tubing Applicable with Reducer

Different diameter tubing can be selected (within a body class) by using a nut and insert bushing (reducer). ● With reducer

Body class	Tubing O.D.														
	Metric size							Inch size							
	3	4	6	8	10	12	19	25	1/8	3/16	1/4	3/8	1/2	3/4	1
2	●	●	○	—	—	—	—	—	●	●	○	—	—	—	—
3	—	—	●	●	○	—	—	—	—	●	○	—	—	—	—
4	—	—	—	—	●	○	—	—	—	—	●	○	—	—	—
5	—	—	—	—	—	●	○	—	—	—	—	●	○	—	—
6	—	—	—	—	—	—	●	○	—	—	—	—	—	●	○

*: Refer to page 49 for information on changing tubing sizes.

⚠ Precautions

Be sure to read this before handling the products. Refer to the back cover for Safety Instructions, and pages 51 and 52 for High Purity Chemical Liquid Valve Precautions.

Piping

⚠ Caution

1. Connect tubing with special tools.

Refer to the catalog "High-Purity Fluoropolymer Fittings Hyper Fittings/LQ1, 2 Series Work Procedure Instructions" (M-E05-1) for connecting tubing and special tools. (Downloadable from the SMC website.)



⚠ Caution

2. Tighten the nut until it touches the end surface of the body, and then tighten it an additional 1/8 turn. If the nut won't turn any further, then it means a sufficient tightening has occurred. Refer to the proper tightening torques shown below.

Tightening Torque for Piping

Body class	Torque [N·m]
2	1.5 to 2.0
3	3.0 to 3.5
4	7.5 to 9.0
5	11.0 to 13.0
6	5.5 to 6.0

LVC Series

Suck Back

A change of volume inside the suck back valve pulls in liquid at the end of the nozzle to prevent dripping.

Single type

Symbol

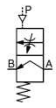

Unit type

Adjustment knob
Adjusts the amount of suck back.

Lock nut
Locks the adjustment knob position.

Symbol

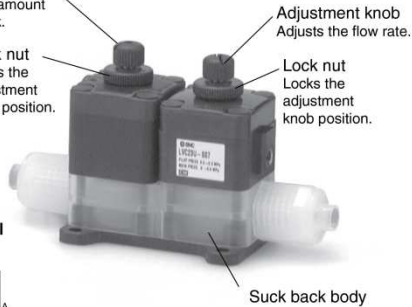
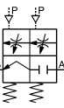

Standard Specifications

Model		LVC23	LVC23U
Tubing O.D. ^{+1 +2}	Metric size	(3), (4), 6	
	Inch size	(1/8), (3/16), 1/4	
Orifice diameter		—	ø3
Flow rate characteristics	Kv	—	0.1
	Cv	—	0.2
Withstand pressure [MPa]		1	
Operating pressure [MPa]		0 to 0.2	
Maximum suck back volume [cm ³]		0.1	
Pilot air pressure [MPa]		0.3 to 0.5	
Pilot port size		M5	
Fluid temperature [°C]		0 to 100	
Ambient temperature [°C]		0 to 60	
Weight [kg]		0.08	0.16

*1: Different diameter tubing shown in () can be selected when used with a reducer. Refer to page 49 for details.

*2: Refer to page 52 for details of the applicable tubing sizes.

How to Order

LVC 2 3 - S 06

Body class

Symbol	Body class
2	2

Valve type

Symbol	Valve type
3	Suck back

Body type

Symbol	Body type
Nii	Single
U	Unit type with 2 way valve

LQ2 integrated fitting

Port B (OUT) different dia. size

Symbol	Application
Nii	Ports A & B same size
Refer to the applicable tubing can be selected within the same body class.	

Applicable tubing size

Symbol	Connecting tubing size	Body class
Metric size		
03	3 x 2	○
04	4 x 3	○
06	6 x 4	◎
Inch size		
03	1/8" x 0.086"	○
05	3/16" x 1/8"	○
07	1/4" x 5/32"	◎

◎ Basic size ○ With reducer

Options

■ With flow rate adjustment

The flow rate is adjusted by controlling the diaphragm stroke.



■ With bypass

A small amount of fluid from the inlet side is allowed to flow continuously to the outlet side by providing a bypass inside the body.

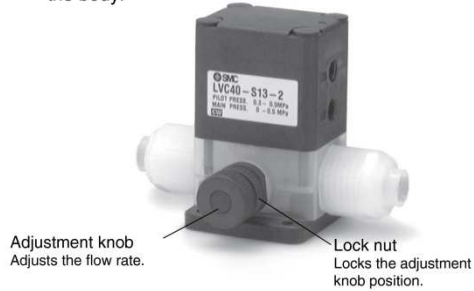

Air Operated Threaded Type LVA Series

How to Order Valve (Single Type)

For N.C. **Body class: 2** LVA 2 0 - 01 □ - A □ - V - Z

For N.O./Double acting **Body class: 2** LVA 2 1 - 01 □ - A □ - V

Body class: 1, 3, 4, 5, 6 LVA 3 0 - 02 □ - A □ - V

Valve type

0	N.C.
1	N.O.
2	Double acting

Body class

Symbol	Body class	Orifice dia.
2	2	ø4
3	3	ø8
4	4	ø12
5	5	ø20
6	6	ø22

Port size

Symbol	Port size	Body class
01	1/8	1
02	1/4	1
01	1/8	2
02	1/4	2
02	1/4	3
03	3/8	3
03	3/8	4
04	1/2	4
04	1/2	5
06	3/4	5
10	1	6

Thread type

Symbol	Body class	Port thread type	Pilot port thread type
Nil	1, 2	Rc	M5
	3, 4, 5, 6	Rc	Rc1/8
	1, 2	NPT	M5
N	3, 4, 5, 6	NPT	NPT1/8
	1, 2	G	M5
F	1, 2	G	M5
	3, 4, 5, 6	G	G1/8

Pilot port thread type

Symbol	Thread type
Nil	Rc
N	NPT
F	G

Specifications

Symbol	None
Nil	None
V	Vacuum specification

*: Applicable to only material symbols A, B, C, F and N. Vacuum specification is not available for LVA1□.

Option

Symbol	None
1	With flow rate adjustment
2	With bypass
3	With flow rate adjustment & bypass
4	With indicator

*: Refer to Variations for option combinations. Options cannot be combined.

Material

Symbol	Body	Actuator section End plate	Diaphragm	Applicable option	Note
A	Stainless steel	PPS	PTFE	1 2 3 4	—
B	PPS	PPS	PTFE	1 2 3 4	Except LVA60
C	PFA	PPS	PTFE	1 2 3 4	—
D	Stainless steel	PPS	NBR	1 2 3 4	Except LVA20-Z, LVA60
E	Stainless steel	PPS	EPDM	1 2 3 4	Except LVA20-Z, LVA60
F	PFA	PVDF	PTFE	1 2 3 4	Hydrofluoric acid compatible (Only LVA40, 50 type)
G	PPS	PPS	NBR	1 2 3 4	Except LVA20-Z, LVA60
H	PPS	PPS	EPDM	1 2 3 4	Except LVA20-Z, LVA60
N	PFA	PPS	PTFE	1 2 3 4	Ammonium hydroxide compatible

Variations

Type	Symbol	Model	Orifice diameter		LVA10		LVA20		LVA30		LVA40		LVA50		LVA60	
			Port size	Body material ¹	ø2	ø4	ø2	ø4	ø8	ø12	ø20	ø22				
Basic		N.C.	1/8	1/4	1/8	1/4	1/4	3/8	3/8	1/2	1/2	3/4	3/4	1	1	1
			1/8	1/4	1/8	1/4	1/4	3/8	3/8	1/2	1/2	3/4	3/4	1	1	1
With flow rate adjustment		N.C.	1/8	1/4	1/8	1/4	1/4	3/8	3/8	1/2	1/2	3/4	3/4	1	1	1
			1/8	1/4	1/8	1/4	1/4	3/8	3/8	1/2	1/2	3/4	3/4	1	1	1
With bypass		N.C.	1/8	1/4	1/8	1/4	1/4	3/8	3/8	1/2	1/2	3/4	3/4	1	1	1
			1/8	1/4	1/8	1/4	1/4	3/8	3/8	1/2	1/2	3/4	3/4	1	1	1
With flow rate adjustment & bypass		N.C.	1/8	1/4	1/8	1/4	1/4	3/8	3/8	1/2	1/2	3/4	3/4	1	1	1
			1/8	1/4	1/8	1/4	1/4	3/8	3/8	1/2	1/2	3/4	3/4	1	1	1
With indicator		N.C.	1/8	1/4	1/8	1/4	1/4	3/8	3/8	1/2	1/2	3/4	3/4	1	1	1
			1/8	1/4	1/8	1/4	1/4	3/8	3/8	1/2	1/2	3/4	3/4	1	1	1

*1: Refer to Material for the applicable optional body materials.

LVA Series



Basic type



LVA-Z



With flow rate adjustment

Standard Specifications

Model	LVA10	LVA20	LVA30	LVA40	LVA50	LVA60	
Orifice diameter	ø2	ø4	ø8	ø12	ø20	ø22	
Port size	1/8, 1/4	1/8, 1/4	1/4, 3/8	3/8, 1/2	1/2, 3/4	1	
Flow rate characteristics	Kv	0.06	0.3	1.4	2.8	5.1	6.8
	Cv	0.07	0.35	1.7	3.3	6	8
Withstand pressure [MPa]	1						
Operating pressure [MPa]	A → B	0 to 0.5	(-94 kPa) ^{*3} 0 to 0.5		(-94 kPa) ^{*3} 0 to 0.4		
	B → A	0 to 0.05	(-94 kPa) ^{*3} 0 to 0.2		(-94 kPa) ^{*3} 0 to 0.1		
Back pressure [MPa]	N.C./N.O. ^{*2}	0.15 or less	0.3 or less		0.2 or less		
	Double acting	0.3 or less	0.4 or less		0.3 or less		
Valve leakage [cm ³ /min]	0 (with water pressure)						
Pilot air pressure [MPa]	0.3 to 0.5						
Pilot port size	Standard	M5	M5 ^{*4}	Rc1/8, NPT1/8, G1/8			
	-Z type ^{*5}	—	Rc1/8, NPT1/8, G1/8	—			
Fluid temperature [°C]	0 to 100 ^{*1}						
Ambient temperature [°C]	0 to 60						
Weight [kg]	Stainless steel	0.12	0.18	0.44	0.86	1.67	1.96
	PPS	0.05	0.08	0.18	0.32	0.73	—
	PFA	0.05	0.09	0.20	0.35	0.78	0.90

*1: 0 to 60°C when the diaphragm is NBR or EPDM.

*2: The N.O. type is not available for LVA10.

*3: When using for vacuum, select the product number ending in "-V". This product cannot be used for vacuum retention. Also, connecting the vacuum to the B port may reduce the life of the product.

*4: Applicable for the LVC21 (N.O.) and LVC22 (double acting) types

*5: Applicable for the LVC20 (N.C.)-Z type

⚠ Precautions

Be sure to read this before handling the products. Refer to the back cover for Safety Instructions, and pages 51 and 52 for High Purity Chemical Liquid Valve Precautions.

Piping

⚠ Caution

1. Avoid using metal fittings with a resin body (taper threads).

This can cause damage to the valve body.

Option

■ With flow rate adjustment

Adjusts the flow rate by controlling the diaphragm stroke.

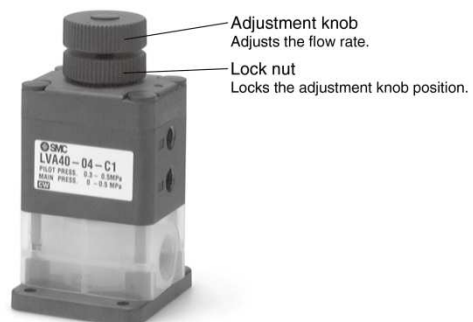

Air Operated, Organic Solvents Compatible Double Ferrule Fittings/Metal Gasket Seal Fittings/Integrated Tubing

LVA Series

How to Order Valve

LVA 2 0 - D 07 - AD - -

Body class

Symbol	Body class	Orifice dia.
2	2	ø4
3	3	ø8
4	4	ø12
5	5	ø20
6	6	ø22

Fitting type

Symbol	Type
D	With double ferrule fittings
G	With metal gasket seal fittings
T	Integrated tubing

Valve type

0	N.C.
1	N.O.
2	Double acting

Applicable tubing size

Symbol	Connecting tubing size	Body class				
		2	3	4	5	6
Metric size						
06	ø6	○				
10	ø10		○			
12	ø12			○		
19	ø19				○	
Inch size						
07	1/4	○				
11	3/8		○			
13	1/2			○		
19	3/4				○	
25	1					○

*: Metric size is only available for fitting types D and T.

Option 2

Nil	None
W	Low water hammer type
E	Body wetted parts equivalent to EP grade

Option 1

Nil	None
1	With flow rate adjustment
4	With indicator
5	High back pressure (0.5 MPa) tolerant
6	High back pressure with flow rate adjustment
9	High back pressure with indicator

*: With flow rate adjustment: Only available with N.C. valve and double acting valve
*: With indicator: Only available with N.C. valve

Material

Symbol	Body	Actuator section	Diaphragm	Seal	Buffer
AD	Stainless steel	ADC	PTFE	FKM	FKM
ND	Stainless steel	ADC	PTFE	EPDM	EPDM

Pilot port thread type

Symbol	Body class	Thread type
Nil	2	M5 x 0.8
	3, 4, 5, 6	Rc1/8
N	3, 4, 5, 6	NPT1/8



LVA30-D11-AD
Double ferrule fittings



LVA60-T25-AD
Integrated tubing



LVA50-G19-AD
Metal gasket seal fittings

Standard Specifications

Model		LVA20	LVA30	LVA40	LVA50	LVA60
Tubing O.D.	Metric size ^{*1}	6	10	12	19	—
	Inch size	1/4	3/8	1/2	3/4	1
Orifice diameter		ø4	ø8	ø12	ø20	ø22
Flow rate characteristics	Kv	0.3	1.4	2.8	5.1	6.8
	Cv	0.35	1.7	3.3	6	8
Withstand pressure [MPa]		1				
Operating pressure [MPa]	Standard	A→B	0 to 0.5		0 to 0.4	
		B→A	0 to 0.2		0 to 0.1	
	High back pressure	A→B	0 to 0.5			
		B→A	0 to 0.4			
Back pressure [MPa]	Standard	N.C./N.O.	0.3 or less		0.2 or less	
		Double acting	0.4 or less		0.3 or less	
	High back pressure ^{*2}	N.C./N.O./Double acting	0.5 or less			
Valve leakage [cm ³ /min]		0 (with water pressure)				
Pilot air pressure [MPa]		0.3 to 0.5 (High back pressure: 0.5 to 0.8) ^{*2}				
Pilot port size		M5	Rc1/8, NPT1/8			
Fluid temperature [°C]		0 to 100				
Ambient temperature [°C]		0 to 60				
Fitting type		With double ferrule fittings, With metal gasket seal fittings, Integrated tubing				

*1: Metric size is only available for fitting types D and T.

*2: High back pressure is optional.



LV□ Series

Applicable Fluids

High Purity Air and Manually Operated Chemical Liquid Valves Material and Fluid Compatibility Check List

Chemicals	Body material			Diaphragm material		
	Stainless steel 316	Fluoro resin PFA	Polyphenylene sulfide resin PPS	Fluoro resin PTFE	Nitrile rubber NBR	Ethylene propylene rubber EPR
Acetone	○	○*1	○*1	○*2	×	×
Ammonium hydroxide	○	○	○	○*2	×	×
Isobutyl alcohol	○	○*1	○*1	○*2	○	○
Isopropyl alcohol	○	○*1	○*1	○*2	○	○
Hydrochloric acid	×	○	○	○	×	×
Ozone (dry)	○	○	○	○	×	○
Hydrogen peroxide Concentration 5% or less, 50°C or less	×	○	○	○	×	×
Ethyl acetate	○	○*1	○*1	○*2	×	×
Butyl acetate	○	○*1	○*1	○*2	×	×
Nitric acid (except fuming nitric acid) Concentration 10% or less	×	○	○	○*2	×	×
DI water (deionized water)	○	○	○	○	×	○
Sodium hydroxide (caustic soda) Concentration 50% or less	○	○	○	○	×	×
Nitrogen gas	○	○	○	○	○	○
Ultrapure water	×	○	○	○	×	×
Toluene	○	○*1	○*1	○*2	×	×
Hydrofluoric acid	×	○	×	○*2	×	×
Sulfuric acid (except fuming sulfuric acid)	×	○	×	○*2	×	×
Phosphoric acid Concentration 80% or less	×	○	×	○	×	×

The material and fluid compatibility check list provides reference values as a guide only.

*1: Use a stainless steel body, as static electricity may be generated.

*2: Use caution as permeation may occur. The permeated fluid may effect the parts of other materials.

Table symbols ○ : Can be used.
○ : Can be used under certain conditions.
× : Cannot be used.

• Compatibility is indicated for fluid temperatures of 100°C or less.

• The material and fluid compatibility check list provides reference values as a guide only, therefore we do not guarantee the application to our product.

• The data above is based on the information presented by the material manufacturers.

• SMC is not responsible for its accuracy and any damage happened because of this data.

• Set the viscosity of a fluid to 300 cp or less.

If a fluid with a high viscosity is used, this may cause inadequate closing of the valve.

LV□ Series

Fittings and Special Tools

Fittings

Changing Tubing Sizes

The tubing size can be changed within the same body class (body size) by replacing the nut and insert bushing.

Body class	Tubing O.D.														
	Metric size						Inch size								
	3	4	6	8	10	12	19	25	1/8	3/16	1/4	3/8	1/2	3/4	1
2	●	●	○	—	—	—	—	—	●	●	○	—	—	—	—
3	—	—	●	●	○	—	—	—	—	—	●	○	—	—	—
4	—	—	—	—	●	○	—	—	—	—	—	●	○	—	—
5	—	—	—	—	—	●	○	—	—	—	—	—	●	○	—
6	—	—	—	—	—	—	●	○	—	—	—	—	—	●	○

Changing the tubing size

Example) Changing the tubing from an O.D. 1/4" to O.D. 1/8" in body class 2.

Prepare an insert bushing and nut for 1/8" O.D. tubing (LQ-2U03) and change the tubing size. (Refer to How to Order Fitting Parts.)

※: Tubing is sold separately.

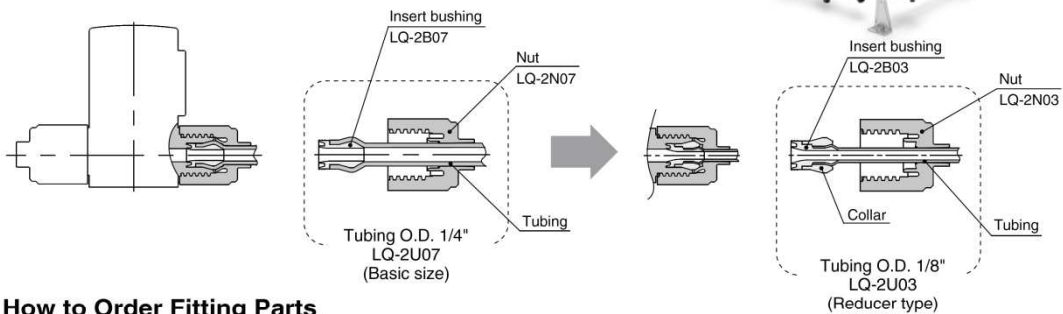

Part Components

	Component parts		
	Nut	Insert	Collar (insert assembly)
○ Basic size	Yes	Yes	No
● Reducer type	Yes	Yes	Yes

Caution

1. Connect tubing with special tools.

Refer to the catalog "High-Purity Fluoropolymer Fittings Hyper Fittings/LQ1, 2 Series Work Procedure Instructions" (M-E05-1) for connecting tubing and special tools. (Downloadable from the SMC website.)

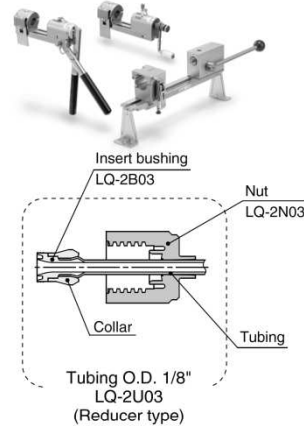

How to Order Fitting Parts

LQ □ - 2 U 03 ※: Type U is recommended when changing tubing sizes.

Fitting type

Symbol	Applicable fitting
Nil	LQ2
1	LQ1

Body class (fittings)

Symbol	Body class (fittings)	Applicable fitting
2	2	LQ1
3	3	
4	4	LQ2
5	5	LQ1
6	6	

Part type

Symbol	Type
U	Insert bushing & nut
B	Insert bushing
N	Nut

Tubing size^{*1}

Symbol	Tubing size	Body class (fittings)	Applicable fitting
03	1/8" x 0.086", 3 x 2	2	LQ1 LQ2
04	4 x 3		
05	3/16" x 1/8"		
06	6 x 4	3	LQ1 LQ2
07	1/4" x 5/32"		
08	6 x 4		
10	8 x 6	4	LQ1
11	10 x 8		
12	12 x 10		
13	3/8" x 1/4"	5	LQ1
19	10 x 8		
25	12 x 10		
12	12 x 10	6	LQ1
13	1/2" x 3/8"		
19	3/4" x 5/8", 19 x 16		
19	3/4" x 5/8", 19 x 16		
25	1" x 7/8", 25 x 22		

※1: Refer to page 52 for details of the applicable tubing sizes.

Failure and countermeasures

Failure	If valves don't operate properly, refer the following failure and perform countermeasures stated in check list.	Causes	Countermeasures
Malfunction	<p>1.Fluid doesn't stop.</p>	<p>1)Malfunction of pilot valve</p> <p>2)Failure of electrical system</p>	<ul style="list-style-type: none"> •Replace valve •Clean air supply source •Check power supply
		<p>1)Lacking pilot pressure (N.O.valve,double acting valve)</p> <p>2)Main pressure is high.</p>	<ul style="list-style-type: none"> •Set proper pressure •Set proper pressure
		<p>1)Back pressure is high</p> <p>2)Particle intrusion</p> <p>3)Mispipng of pilot port</p>	<ul style="list-style-type: none"> •Set proper pressure •Eliminate particles and install filter. •Check if the connection of pilot port is correct.
		<p>1)Malfunction of pilot valve</p> <p>2)Failure of electrical system</p>	<ul style="list-style-type: none"> •Replace valve •Clean air supply source •Check power supply
Malfunction	<p>2.Fluid doesn't stop</p>	<p>1)Malfunction of pilot valve</p> <p>2)Failure of electrical system</p>	<ul style="list-style-type: none"> •Replace valve •Clean air supply source •Check power supply
		<p>1)Lacking pilot pressure (N.C.valve)</p>	<ul style="list-style-type: none"> •Set proper pressure
		<p>1)No main pressure</p> <p>2)Side failure of piston packing.</p>	<ul style="list-style-type: none"> •Check to proper pressure •Replace product.
Failure of air tight	1.Internal leakage	<p>1)Intrusion of particles</p> <p>2)Flaws on valve seat</p>	<ul style="list-style-type: none"> •Eliminate particles and install filter. •Replace product
	2.External leakage	<p>1)Tightening failure</p> <p>2)Breakage of diaphragm</p>	<ul style="list-style-type: none"> •Tighten additionally •Replace product

Revision history

SMC Corporation

4-14-1, Sotokanda, Chiyoda-ku, Tokyo 101-0021 JAPAN

Tel: + 81 3 5207 8249 Fax: +81 3 5298 5362

URL <https://www.smcworld.com>

Note: Specifications are subject to change without prior notice and any obligation on the part of the manufacturer.
© 2019 SMC Corporation All Rights Reserved