



# Operation Manual

PRODUCT NAME

Rotary Actuated Air Gripper

MODEL / Series / Product Number

M(D)HR3-10

M(D)HR3-15

**SMC Corporation**

# Contents

## Safety Instructions

1. Product Specifications
  
2. Operating method or operation
  - 2-1. Design precautions
  - 2-2. Selection
  - 2-3. Mounting
  - 2-4. Air supply
  - 2-5. Piping
  - 2-6. Operating environment
  - 2-7. Lubrication
  
3. Maintenance
  - 3-1. Notes
  - 3-2. Structural drawing / Parts List
  - 3-3. For use without cover



# Safety Instructions

These safety instructions are intended to prevent hazardous situations and/or equipment damage. These instructions indicate the level of potential hazard with the labels of “Caution,” “Warning” or “Danger.” They are all important notes for safety and must be followed in addition to International Standards (ISO/IEC)\*1), and other safety regulations.

\*1) ISO 4414: Pneumatic fluid power -- General rules relating to systems.

ISO 4413: Hydraulic fluid power -- General rules relating to systems.

IEC 60204-1: Safety of machinery -- Electrical equipment of machines .(Part 1: General requirements)

ISO 10218: Manipulating industrial robots -Safety.

etc.



## Caution

**Caution** indicates a hazard with a low level of risk which, if not avoided, could result in minor or moderate injury.



## Warning

**Warning** indicates a hazard with a medium level of risk which, if not avoided, could result in death or serious injury.



## Danger

**Danger** indicates a hazard with a high level of risk which, if not avoided, will result in death or serious injury.

## Warning

### **1. The compatibility of the product is the responsibility of the person who designs the equipment or decides its specifications.**

Since the product specified here is used under various operating conditions, its compatibility with specific equipment must be decided by the person who designs the equipment or decides its specifications based on necessary analysis and test results.

The expected performance and safety assurance of the equipment will be the responsibility of the person who has determined its compatibility with the product.

This person should also continuously review all specifications of the product referring to its latest catalog information, with a view to giving due consideration to any possibility of equipment failure when configuring the equipment.

### **2. Only personnel with appropriate training should operate machinery and equipment.**

The product specified here may become unsafe if handled incorrectly.

The assembly, operation and maintenance of machines or equipment including our products must be performed by an operator who is appropriately trained and experienced.

### **3. Do not service or attempt to remove product and machinery/equipment until safety is confirmed.**

1. The inspection and maintenance of machinery/equipment should only be performed after measures to prevent falling or runaway of the driven objects have been confirmed.

2. When the product is to be removed, confirm that the safety measures as mentioned above are implemented and the power from any appropriate source is cut, and read and understand the specific product precautions of all relevant products carefully.

3. Before machinery/equipment is restarted, take measures to prevent unexpected operation and malfunction.

### **4. Contact SMC beforehand and take special consideration of safety measures if the product is to be used in any of the following conditions.**

1. Conditions and environments outside of the given specifications, or use outdoors or in a place exposed to direct sunlight.

2. Installation on equipment in conjunction with atomic energy, railways, air navigation, space, shipping, vehicles, military, medical treatment, combustion and recreation, or equipment in contact with food and beverages, emergency stop circuits, clutch and brake circuits in press applications, safety equipment or other applications unsuitable for the standard specifications described in the product catalog.

3. An application which could have negative effects on people, property, or animals requiring special safety analysis.

4. Use in an interlock circuit, which requires the provision of double interlock for possible failure by using a mechanical protective function, and periodical checks to confirm proper operation.



# Safety Instructions

## Caution

### **The product is provided for use in manufacturing industries.**

The product herein described is basically provided for peaceful use in manufacturing industries.

If considering using the product in other industries, consult SMC beforehand and exchange specifications or a contract if necessary.

If anything is unclear, contact your nearest sales branch.

## **Limited warranty and Disclaimer/Compliance Requirements**

The product used is subject to the following “Limited warranty and Disclaimer” and “Compliance Requirements”.

Read and accept them before using the product.

### **Limited warranty and Disclaimer**

1. The warranty period of the product is 1 year in service or 1.5 years after the product is delivered, whichever is first.\*2)

Also, the product may have specified durability, running distance or replacement parts. Please consult your nearest sales branch.

2. For any failure or damage reported within the warranty period which is clearly our responsibility, a replacement product or necessary parts will be provided.

This limited warranty applies only to our product independently, and not to any other damage incurred due to the failure of the product.

3. Prior to using SMC products, please read and understand the warranty terms and disclaimers noted in the specified catalog for the particular products.

\*2) Vacuum pads are excluded from this 1 year warranty.

A vacuum pad is a consumable part, so it is warranted for a year after it is delivered.

Also, even within the warranty period, the wear of a product due to the use of the vacuum pad or failure due to the deterioration of rubber material are not covered by the limited warranty.

### **Compliance Requirements**

1. The use of SMC products with production equipment for the manufacture of weapons of mass destruction(WMD) or any other weapon is strictly prohibited.

2. The exports of SMC products or technology from one country to another are governed by the relevant security laws and regulation of the countries involved in the transaction. Prior to the shipment of a SMC product to another country, assure that all local rules governing that export are known and followed.

## Caution

### **SMC products are not intended for use as instruments for legal metrology.**

Measurement instruments that SMC manufactures or sells have not been qualified by type approval tests relevant to the metrology (measurement) laws of each country.

Therefore, SMC products cannot be used for business or certification ordained by the metrology (measurement) laws of each country.

# 1. Specifications

## Specifications

Model		M(D)HR3-10	M(D)HR3-15
Nominal size		10	15
Fluid		Air	
Operation pressure MPa		0.2 to 0.6	0.15 to 0.6
Ambient and fluid temperature °C		0 to 60	
Repeatability		±0.01	
Max. operating frequency c.p.m.		180	
Lubrication		Not required	
Action		Double acting	
Note 1)	External hold	7	13
Holding force N	Internal hold	6.5	12
Opening stroke (Both side) mm		6	8
Note 2)	MHR3	120	225
Weight g	MDHR3	125	230

Note 1) Pressure: 0.5MPa.

Note 2) Not including auto switch.

## 2. Operation Guide for Air Gripper.

### 2-1 Design precautions

#### Warning

1. A protective cover is recommended to minimize the risk of personal injury due to accidental contact with moving parts of the gripper.
2. Measures should be taken to protect against unexpected drop of work due to loss of air pressure.
3. Contact SMC for other applications than work transfer. (i.e. Positioning, crimping)

### 2-2 Selection

#### Warning

1. Keep the holding point within the specified range of the holding distance.

When the holding point distance becomes large, the finger attachment applies an excessively large load to the cross roller section, causing excessive play of the fingers and possibly leading to premature failure. Refer to catalog for details.

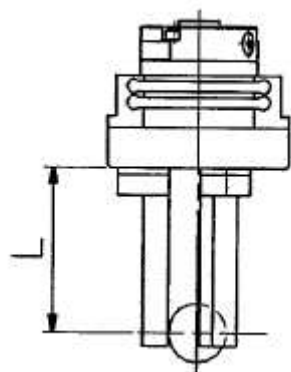

NG : L is too long.

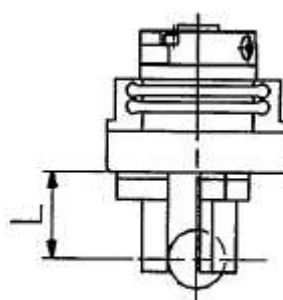

OK : L is correct.

2. Attachment should be designed as light and short as possible.
  - 1) Long and heavy attachment increases the inertia force to open or close the finger. It may cause unsteady movement of fingers and have an adverse effect on life.
  - 2) Even if holding point remains within the limited range, make the attachment as light and short as possible. Please refer the catalogue in details.

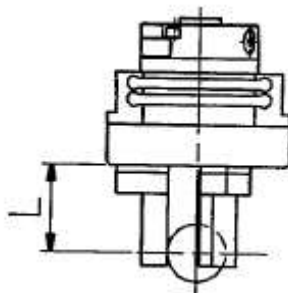

- 3) Please use some pieces or larger size if long work or large work.

3. Please set roll on attachment if work is extra thin or extra fine.

Product without roll off may cause incorrect positioning or incorrect holding, due to unstable holding.

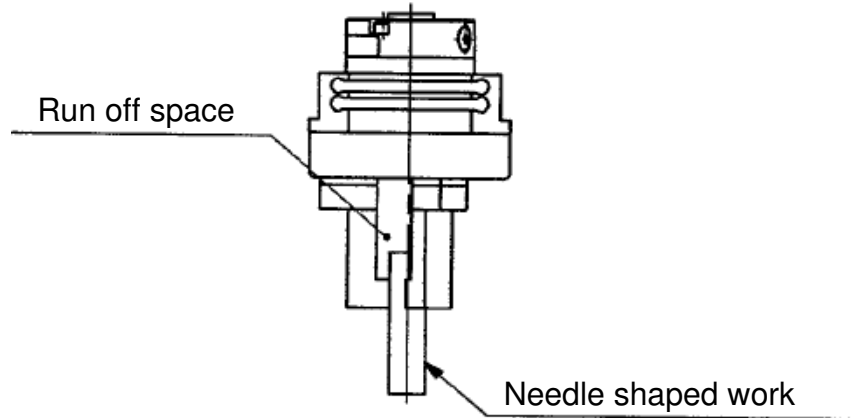

4. Select the model whose holding force is sufficient against work weight.  
Incorrect selection may lead to release of work etc. Refer to “Effective holding force” and information to select the model by weight of work.
5. Do not use in applications where excessive external force or impact force may be applied to gripper. It may cause malfunction. Consult SMC with regard to any other application.
6. Select a model to have allowance in opening/closing width to work.  
<If no allowance is provided>
  - 1) Holding may be insecure due variations in air gripper opening/closing width or in work diameter.
  - 2) If auto-switch is used, detection failure may occur. Refer to hysteresis of auto-switch in each series to secure extra stroke for hysteresis. Especially when dual color advance waterproof auto-switch is used, stroke may be restricted depending on the setting of the lamp color at detection.

## 2-3 Mounting

### Warning

1. Do not drop nor dent the gripper when mounting. Slight deformation can cause unaccuracy or malfunction.
2. Tighten the screw within the specified torque range to mount the attachment.  
The tightening with larger torque than specified range may cause malfunction, while the tightening with smaller torque may allow movement of holding position and dropping of work.

### How to locate finger and attachment

- Positioning of finger open/close direction

Position by finger pin and the attachment pin hole. C is the dimension of shorter diameter of the pin hole which is mating dimension referring to open/close direction. B is the dimension of longer diameter of the long oval and shall be set as clearance for adjustment for width direction.

- Finger width direction positioning

Position by the finger with and the attachment finger insert groove A.

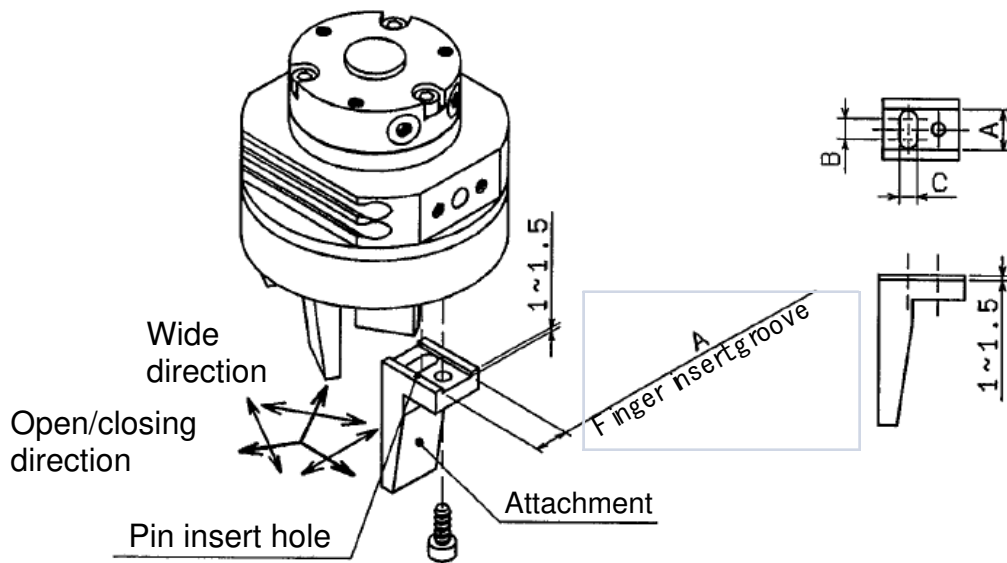

### How to mount the attachment on fingers

When mounting an attachment on a finger, hold the finger with a spanner to prevent the finger from being distorted.

To mount attachment, screw bolts in finger mounting female threads with the tightening torque in the table below.

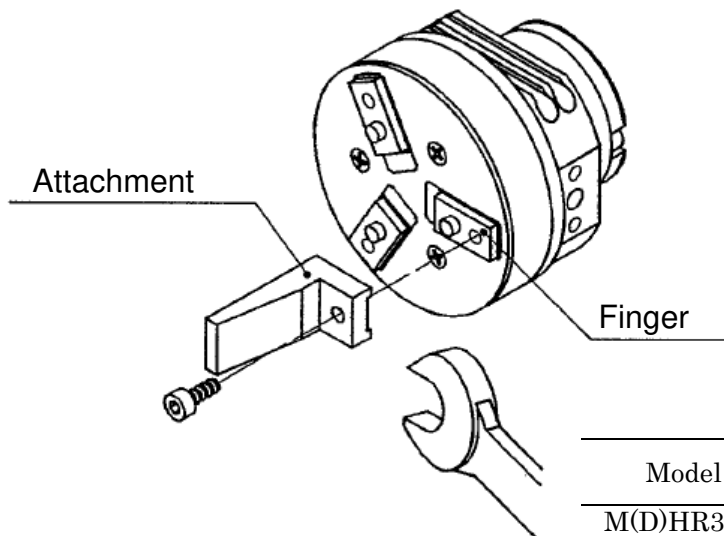

Model	Mounting bolt	Max. tightening Torque N·m
M(D)HR3-10	M3x0.5	0.59
M(D)HR3-15		



## Mounting of gripper

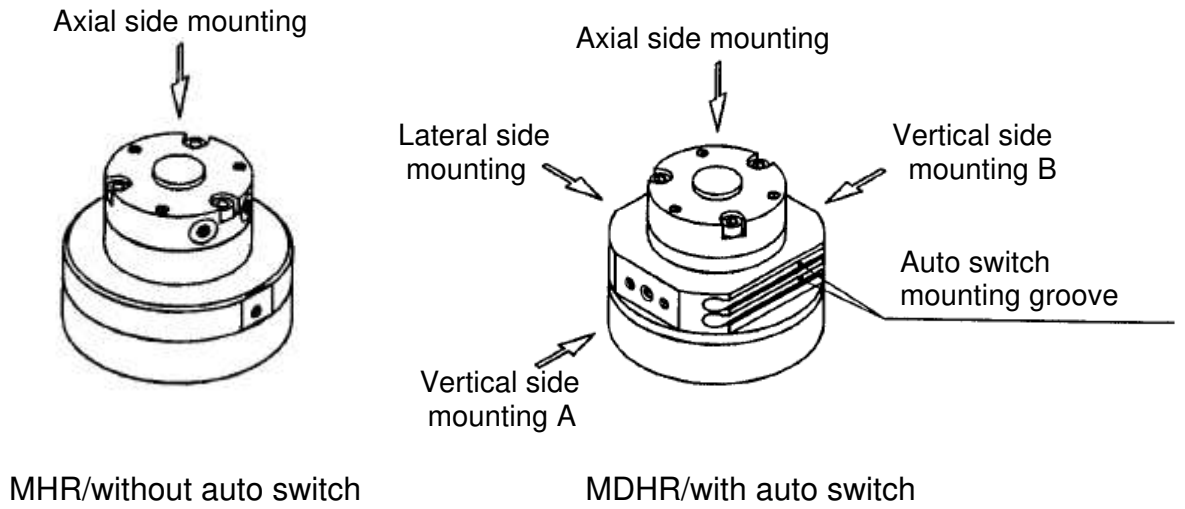

Model	Axial side mounting	Lateral side mounting	Vertical side mounting	
			A	B
MHR3-*	●	—	—	—
MDHR3-*	●	●	●	●

## Axial side mounting

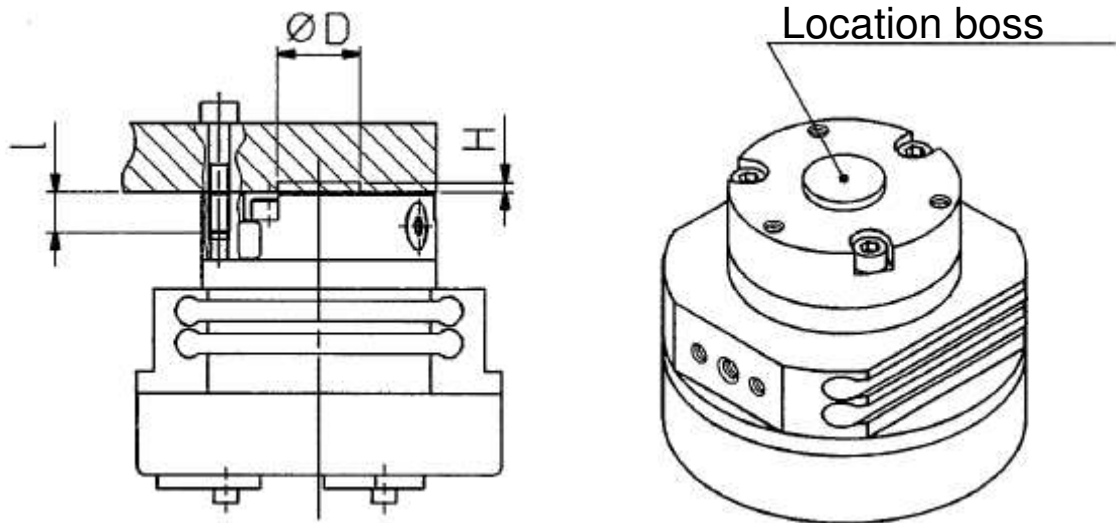

Model	Mounting bolt	Max. tightening torque N·m	Max. screw-in depth (l) mm	Location boss	
				D mm	H mm
M(D)HR3-10	M3x0.5	0.88	6	$\varnothing 9h9_{-0.036}^0$	1
M(D)HR3-15				$\varnothing 12h9_{-0.043}^0$	1.5

Lateral side mounting

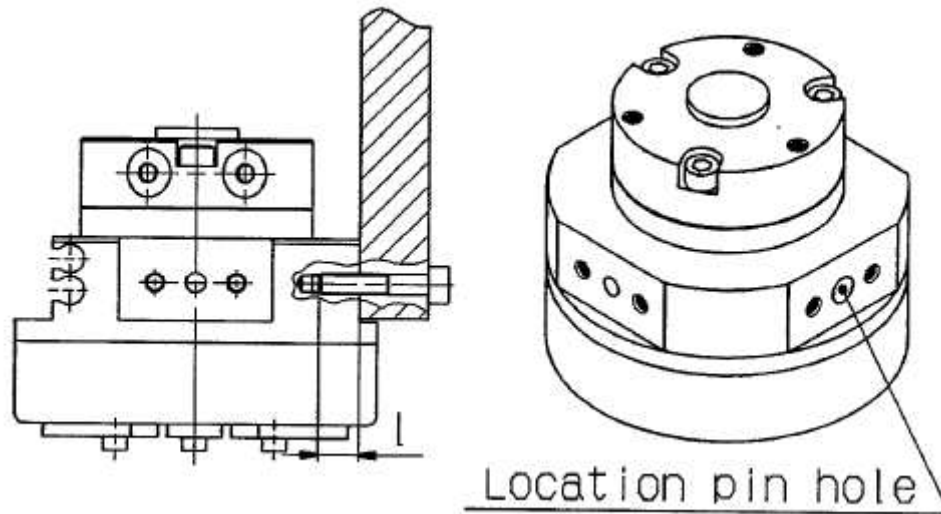

Model	Mounting bolt	Max. tightening torque N·m	Max. screw-in depth (l) mm	Location pin hole	
				Hole diameter d mm	Height h mm
M(D)HR3-10 M(D)HR3-15	M3x0.5	0.88	6	$\phi 3^{+0.02}_0$	6

Vertical side mounting

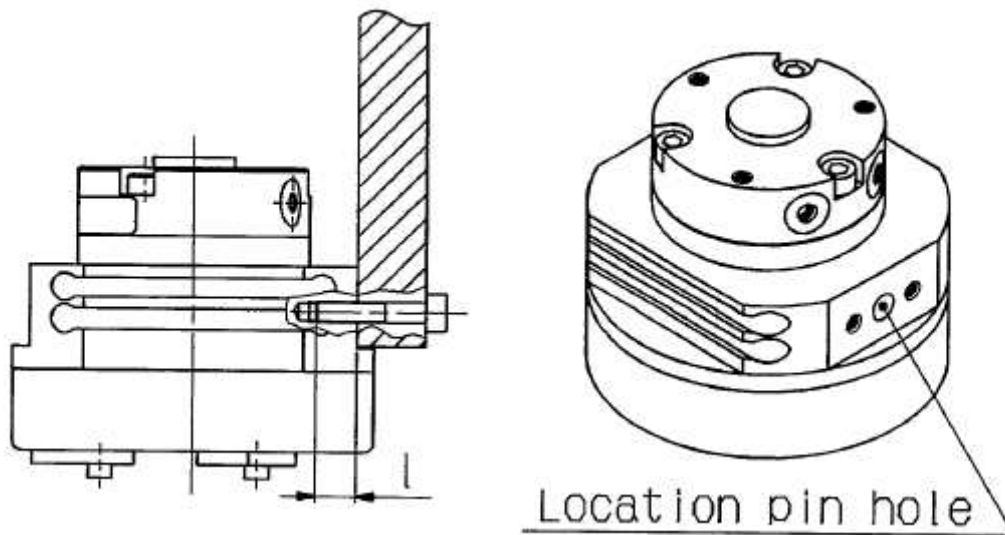

Model	Mounting bolt	Max. tightening torque N·m	Max. screw-in depth (l) mm	Location pin hole	
				Hole diameter d mm	Height h mm
M(D)HR3-10 M(D)HR3-15	M3x0.5	0.88	6	$\phi 3^{+0.02}_0$	6

## ⚠ Caution

1. Avoid the excessive force on fingers when mounting the attachment.  
Any change of fingers may cause the malfunction and deteriorate the accuracy.
2. Avoid external force to fingers. Fingers may be damaged by continual lateral or the impact load.

Provide clearance to prevent the work or the attachment from striking against any object at the stroke end.

### 1. Stroke end in finger opening condition

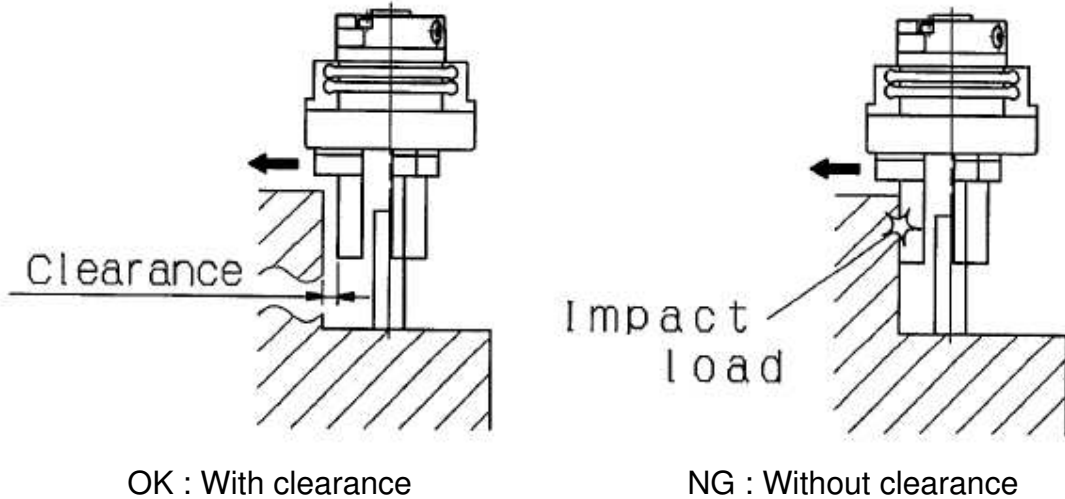

### 2. Air gripper traveling stroke end

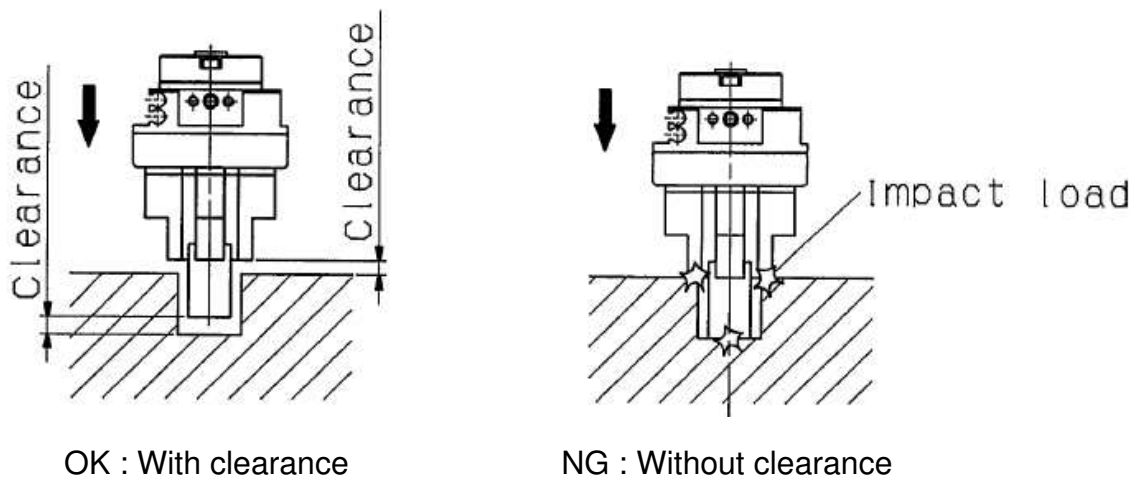

3. Adjust the holding point so that excessive force will not be applied on fingers when inserting the work.

Confirm that the gripper can operate without receiving any shock by testing with manual operation or low-speed operation.

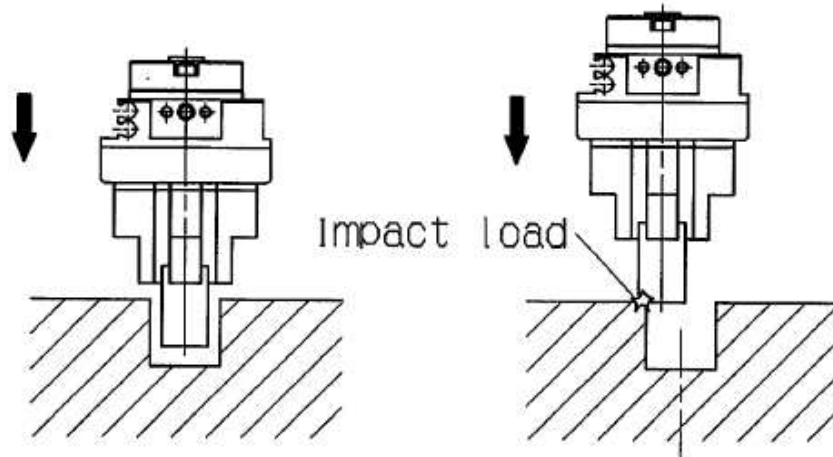

OK : Aligned

NG : Not aligned

4. Speed control of finger full stroke slower than 0.2sec may cause slipstick or literally stop the operation.

## 2-4 Air supply

### Warning

1. Use clean air.

Do not use compressed air contains chemicals, salinity, corrosive gas or synthetic oil with organic solvent. Using it may cause malfunction or damage of air gripper.

### Caution

1. Mount air filter.

Mount air filter near valve and before air gripper. Select filtration rating of  $5\mu\text{m}$  or less.

2. Install after-cooler, air dryer and drain catch.

Compressed air contains a large amount of drain may cause malfunction of valve and other pneumatic equipment.

3. Use air gripper within the specified fluid and ambient temperature range.

If air gripper is used below  $5^{\circ}\text{C}$ , moisture inside the circuit is frozen and may cause damage of packings or malfunction. Take preventative measures for freezing.

Refer to SMC "Compressed Air Cleaning System" for the details of compressed air quality described above.

## 2-5 Piping

### ⚠ Caution

1. Preparation before piping.  
Thoroughly flush the fittings to prevent dust or chips from entering the gripper.

### Air gripper piping method

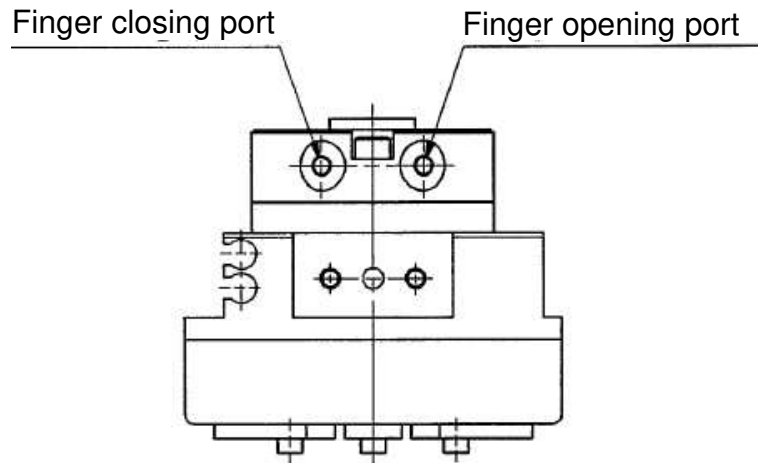

Connection port

Model	Connection port
M(D)HR3-10	M3x0.5
M(D)HR3-15	

## 2-6 Operating environment

### ⚠ Warning

1. Do not use in environment of corrosive grass, salt water, water, nor vapor.
2. Do not use in direct sun light.
3. Do not subject to excessive vibration.
4. Do not use close to flame.
5. Use a cover when gripper must be used in an environment where dust or cutting oil will come in contact with gripper.
6. Consult SMC for the use in any other special environment.

## 2-7 Lubrication

### ⚠ Caution

1. This product is lubrication.  
Although operable with lubrication, it may cause stick-slip.

### 3. Maintenance

---

<b>3-1 Notes</b>
------------------

 **Warning**

1. Do not enter the transfer line nor put the object. It may cause unexpected accidents.
2. Do not enter your hands between finger and attachment. It may cause unexpected accidents.
3. Confirm that no work is held by fingers before releasing the compressed air to remove the gripper from the line. Dropping of work can be dangerous.

### 3-2 Structural drawing / Parts List

MHR 3

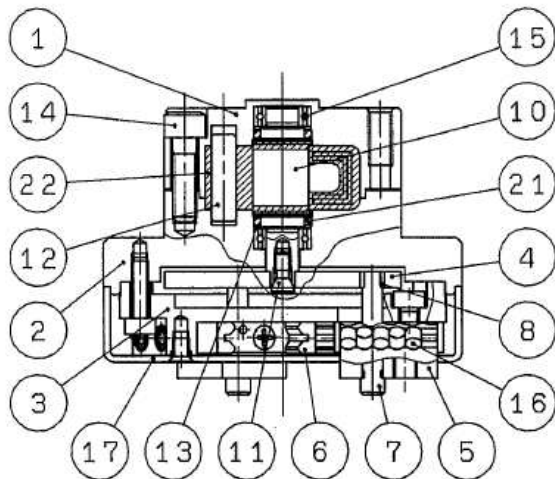

MDHR 3

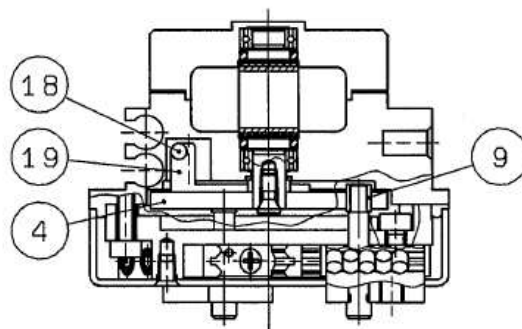
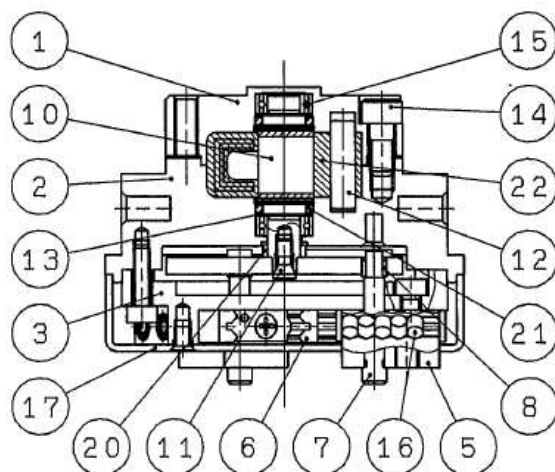

Component Parts

No.	Description	Material	Note
1	Body	Aluminum alloy	Hard anodized
2	Adaptor Body	Aluminum alloy	Hard anodized
3	Guide holder	Stainless steel	
4	Cam	Steel	Nitriding
5	Finger ass'y	Stainless steel	Heat treatment
6	Guide	Stainless steel	Heat treatment
7	Pin	Carbon steel	Heat treatment Electroless nickel plated
8	Pin roller	Stainless steel	Nitriding
9	Pin roller A	Stainless steel	Nitriding
10	Vane shaft	Stainless steel NBR	
11	Joint bolt	Steel	Zinc chrome

Component Parts

No.	Description	Material	Note
12	Stopper	Resin	
13	Back-up ring	Stainless steel	
14	Hexagon socket head bolt	Stainless steel	
15	Bearing	High carbon chrome steel	
16	Cylindrical roller	Stainless steel	
17	Cover	Aluminum alloy	
18	Magnet	Rare earth magnet	
19	Magnet holder	Aluminum alloy	Hard anodized
20	Roller	Stainless steel	Nitriding
21	O ring	NBR	
22	Stopper packing	NBR	

### 3-3 For use without cover

The cover can be replaced easily by taking off cross-recessed and flat head machine screw. When the cover is replaced, pay attention to prevent coarse particulates, chips, cutting lubricant from entering into the inside.

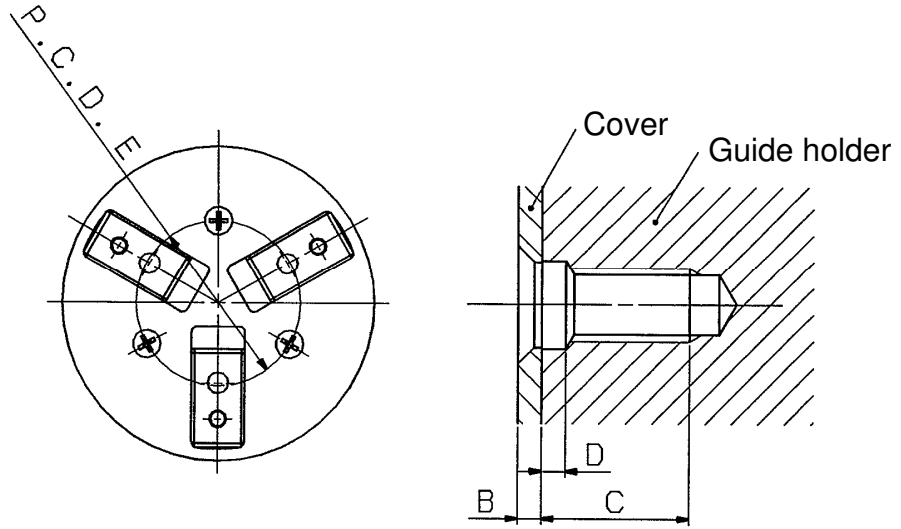
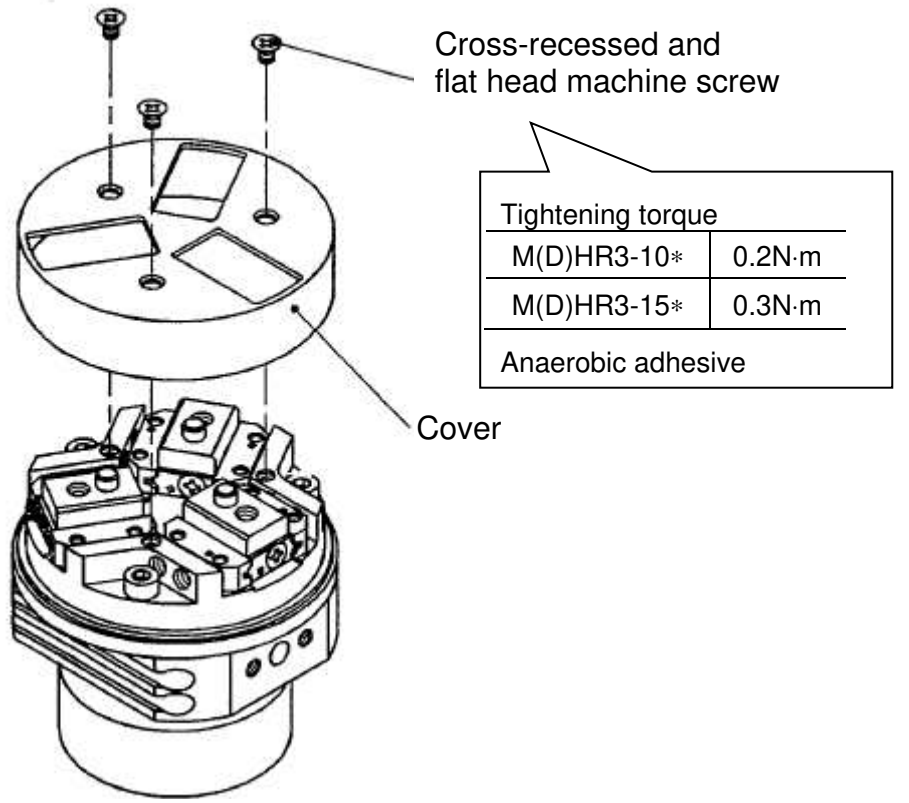

	A (Screw size)	B (Cover thickness)	C (screw depth)	D (Counterbore)	E (P.C.D.)
M(D)HR3-10	M2x0.4	0.8	3	Bore $\phi 2.5$ Depth 0.5	25
M(D)HR3-15	M2.5x0.45	0.8	5	Bore $\phi 3$ Depth 0.8	28



Revision history
------------------

## SMC Corporation

4-14-1, Sotokanda, Chiyoda-ku, Tokyo 101-0021 JAPAN

Tel: + 81 3 5207 8249 Fax: +81 3 5298 5362

URL <https://www.smcworld.com>