



Operation Manual

PRODUCT NAME

Parallel Type Air Gripper

MODEL / Series / Product Number

MHL2-10D*

MHL2-16D*

MHL2-20D*

MHL2-25D*

MHL2-32D*

MHL2-40D*

SMC Corporation

Contents

1. Safety Instructions
2. Product Specifications
3. Operating method or operation
 - 3-1. Operating environment
 - 3-2. Air supply
 - 3-3. Lubrication
 - 3-4. Mounting
 - 3-5. Finger attachment
 - 3-6. Selection
 - 3-7. Installation and setting of auto switch
 - 3-8. Piping
4. Maintenance · Inspection
 - 4-1. Maintenance · Inspection
 - 4-2. Parts list
 - 4-3. Piston Ass'y replacement procedure
 - 4-4. Replacement procedure of packing set



Safety Instructions

These safety instructions are intended to prevent hazardous situations and/or equipment damage. These instructions indicate the level of potential hazard with the labels of “Caution,” “Warning” or “Danger.” They are all important notes for safety and must be followed in addition to International Standards (ISO/IEC)*1), and other safety regulations.

*1) ISO 4414: Pneumatic fluid power -- General rules relating to systems.

ISO 4413: Hydraulic fluid power -- General rules relating to systems.

IEC 60204-1: Safety of machinery -- Electrical equipment of machines .(Part 1: General requirements)

ISO 10218: Manipulating industrial robots -Safety.

etc.



Caution

Caution indicates a hazard with a low level of risk which, if not avoided, could result in minor or moderate injury.



Warning

Warning indicates a hazard with a medium level of risk which, if not avoided, could result in death or serious injury.



Danger

Danger indicates a hazard with a high level of risk which, if not avoided, will result in death or serious injury.

Warning

1. The compatibility of the product is the responsibility of the person who designs the equipment or decides its specifications.

Since the product specified here is used under various operating conditions, its compatibility with specific equipment must be decided by the person who designs the equipment or decides its specifications based on necessary analysis and test results.

The expected performance and safety assurance of the equipment will be the responsibility of the person who has determined its compatibility with the product.

This person should also continuously review all specifications of the product referring to its latest catalog information, with a view to giving due consideration to any possibility of equipment failure when configuring the equipment.

2. Only personnel with appropriate training should operate machinery and equipment.

The product specified here may become unsafe if handled incorrectly.

The assembly, operation and maintenance of machines or equipment including our products must be performed by an operator who is appropriately trained and experienced.

3. Do not service or attempt to remove product and machinery/equipment until safety is confirmed.

1. The inspection and maintenance of machinery/equipment should only be performed after measures to prevent falling or runaway of the driven objects have been confirmed.

2. When the product is to be removed, confirm that the safety measures as mentioned above are implemented and the power from any appropriate source is cut, and read and understand the specific product precautions of all relevant products carefully.

3. Before machinery/equipment is restarted, take measures to prevent unexpected operation and malfunction.

4. Contact SMC beforehand and take special consideration of safety measures if the product is to be used in any of the following conditions.

1. Conditions and environments outside of the given specifications, or use outdoors or in a place exposed to direct sunlight.

2. Installation on equipment in conjunction with atomic energy, railways, air navigation, space, shipping, vehicles, military, medical treatment, combustion and recreation, or equipment in contact with food and beverages, emergency stop circuits, clutch and brake circuits in press applications, safety equipment or other applications unsuitable for the standard specifications described in the product catalog.

3. An application which could have negative effects on people, property, or animals requiring special safety analysis.

4. Use in an interlock circuit, which requires the provision of double interlock for possible failure by using a mechanical protective function, and periodical checks to confirm proper operation.



Safety Instructions

Caution

The product is provided for use in manufacturing industries.

The product herein described is basically provided for peaceful use in manufacturing industries.

If considering using the product in other industries, consult SMC beforehand and exchange specifications or a contract if necessary.

If anything is unclear, contact your nearest sales branch.

Limited warranty and Disclaimer/Compliance Requirements

The product used is subject to the following “Limited warranty and Disclaimer” and “Compliance Requirements”.

Read and accept them before using the product.

Limited warranty and Disclaimer

1. The warranty period of the product is 1 year in service or 1.5 years after the product is delivered, whichever is first.*2)

Also, the product may have specified durability, running distance or replacement parts. Please consult your nearest sales branch.

2. For any failure or damage reported within the warranty period which is clearly our responsibility, a replacement product or necessary parts will be provided.

This limited warranty applies only to our product independently, and not to any other damage incurred due to the failure of the product.

3. Prior to using SMC products, please read and understand the warranty terms and disclaimers noted in the specified catalog for the particular products.

*2) Vacuum pads are excluded from this 1 year warranty.

A vacuum pad is a consumable part, so it is warranted for a year after it is delivered.

Also, even within the warranty period, the wear of a product due to the use of the vacuum pad or failure due to the deterioration of rubber material are not covered by the limited warranty.

Compliance Requirements

1. The use of SMC products with production equipment for the manufacture of weapons of mass destruction(WMD) or any other weapon is strictly prohibited.

2. The exports of SMC products or technology from one country to another are governed by the relevant security laws and regulation of the countries involved in the transaction. Prior to the shipment of a SMC product to another country, assure that all local rules governing that export are known and followed.

Caution

SMC products are not intended for use as instruments for legal metrology.

Measurement instruments that SMC manufactures or sells have not been qualified by type approval tests relevant to the metrology (measurement) laws of each country.

Therefore, SMC products cannot be used for business or certification ordained by the metrology (measurement) laws of each country.

2. Specifications

Model/Stroke

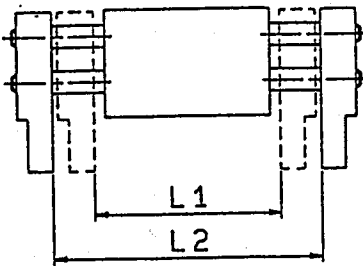

Model	Cylinder bore mm	Max. frequency c.p.m	Stroke mm (L ₂ -L ₁)	Close mm (L ₁)	Open mm (L ₂)	Weight (g)
MHL2-10D	10	60	20	56	76	280
MHL2-10D1		40	40	78	118	345
MHL2-10D2			60	96	156	425
MHL2-16D	16	60	30	68	98	585
MHL2-16D1		40	60	110	170	795
MHL2-16D2			80	130	210	935
MHL2-20D	20	60	40	82	122	1,025
MHL2-20D1		40	80	142	222	1,495
MHL2-20D2			100	162	262	1,690
MHL2-25D	25	60	50	100	150	1,690
MHL2-25D1		40	100	182	282	2,560
MHL2-25D2			120	200	320	2,775
MHL2-32D	32	30	70	150	220	2,905
MHL2-32D1		20	120	198	318	3,820
MHL2-32D2			160	242	402	4,655
MHL2-40D	40	30	100	188	288	5,270
MHL2-40D1		20	160	246	406	6,830
MHL2-40D2			200	286	486	7,905

Display symbol

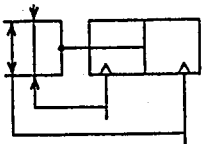

Note) Open/Close width is the value of holding on work OD.

Specifications

Cylinder bore mm	10	16	20	25	32	40
Operating fluid	Air					
Operation type	Double acting					
Operating pressure MPa{kgf/cm ² }	0.15~0.6 {1.5~6.1}	0.1~0.6 {1~6.1}				
Ambient & Operating fluid temperature	-10~60°C					
Repeatability (mm)	±0.1					
Lubrication	Not required					
(Note) Effective holding force N {kgf}	14	45	74	131	228	396
{Pressure 0.5MPa (5.1kgf/cm ²)}	{1.4}	{4.6}	{7.5}	{13.4}	{23.4}	{40.4}

Note) Holding position is 40mm for cylinder bore size 10, 16, 20, 25, and 80mm for cylinder bore size 32, 40.

3. Operating Method

3-1 Operating environment

Warning

- ① Contact SMC, for the use in environment especially have effect of corrosive gases, salt water, water, and vapor atmosphere or sticking.

Depending on environment, it will have bad influences upon dust cover and packing and will lead to operating failure and short life time. Please contact SMC after confirming the kind of environment.

- ② Shut-off sun light where expose to direct sun light.
- ③ Do not use subject to vibration and impact.
- ④ Do not use in heat source and radiating heat.
- ⑤ Use a cover where dust or cutting oil come in contact with gripper.
- ⑥ Consult SMC for the use in any other special environment.

3-2 Air supply

Warning

- ① Type of fluid

This product is designed for use with compressed air. Contact SMC in case a different fluid is to be used.

Contact SMC regarding the types of fluids which can be used in products designed for use with general purpose fluid.

- ② Large amount of drain

Compressed air which contained a large amount of drain may result malfunction of pneumatic product. Install air dryer or drain catch in front of the filter.

- ③ Drainage control

If the drainage of air filter is not performed, drain will flow out to the outlet side and may cause malfunction on pneumatic equipment.

In case drainage control is difficult, use of filter with auto drain is recommended.

Refer to "Air Cleaning Equipment" catalogue for details of above compressed air quality.

- ④ Type of air

Do not use compressed air containing chemicals, organic solvents. Salt or corrosive gases, as this can cause damage and malfunction.

3-3 Lubrication

Caution

- ① Non-lube type gripper is lubricated already. Therefore, it is not necessary to lubricate before using.

When lubrication the gripper, use the turbine oil class1 (non-additive) ISO VG32 and refuel continually. When lubrication has been started, it must be continued throughout the life of the gripper or malfunction may result.

3-4 Mounting

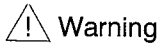

Warning

① Tighten the screw within the specified torque range to mount the gripper.

Tightening with larger torque may cause malfunction, while tightening with smaller torque may allow movement of the gripper and release of work.

Mounting of gripper

Vertical mounting

Body tapped

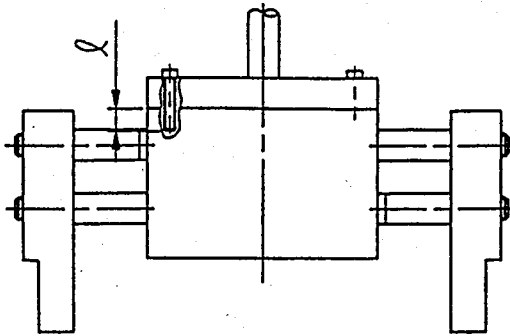

Horizontal mounting

Body tapped

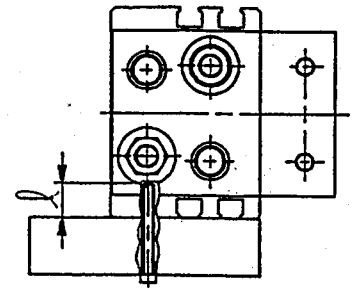

Model	Bolt used	Max. tightening torque N·m{kgf·cm}	Max. screw-in depth l (mm)
MHL2-10D□	M4×0.7	2.1{21}	8
MHL2-16D□	M5×0.8	4.3{44}	10
MHL2-20D□	M6×1	7.3{74}	12
MHL2-25D□	M8×1.25	17.7 {180}	16
MHL2-32D□	M8×1.25	18 {183}	16
MHL2-40D□	M10×1.5	36 {367}	20

Model	Bolt used	Max. tightening torque N·m{kgf·cm}	Max. screw-in depth l (mm)
MHL2-10D□	M4×0.7	1.4{14}	5
MHL2-16D□	M5×0.8	2.8{29}	7
MHL2-20D□	M6×1	4.8{49}	7
MHL2-25D□	M8×1.25	12 {122}	7
MHL2-32D□	M8×1.25	12 {122}	11
MHL2-40D□	M10×1.5	24 {245}	12

Through-hole mounting

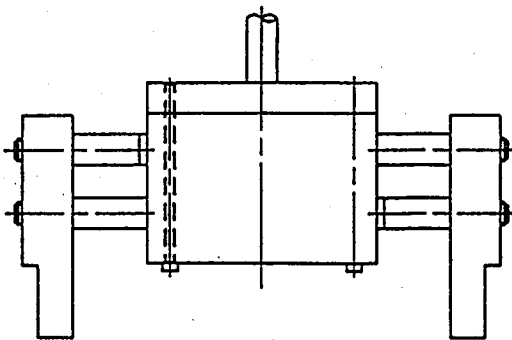

Model	Bolt used	Max. tightening torque N·m{kgf·cm}
MHL2-10D□	M4×0.7	2.1{21}
MHL2-16D□	M5×0.8	4.3{44}
MHL2-20D□	M6×1	7.3{74}
MHL2-25D□	M8×1.25	17.7 {180}

- ② Avoid the excessive force on fingers when mounting the attachment.
- ③ Adjust and confirm to avoid external force to fingers.

Life time may be shortened by continual lateral to the fingers. Provide clearance to prevent the work or the attachment from striking against any object at the stroke end.

1. Stroke end when fingers are open

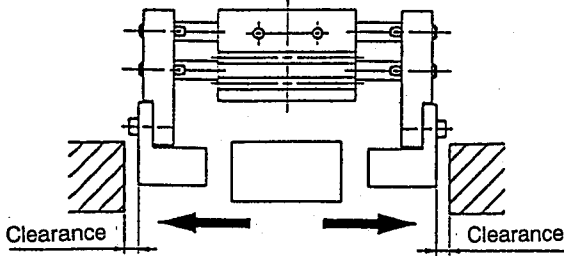

○ With clearance

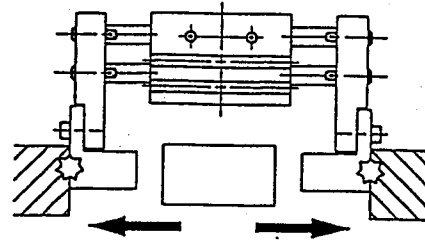

× Without clearance

2. Stroke end when gripper is moving

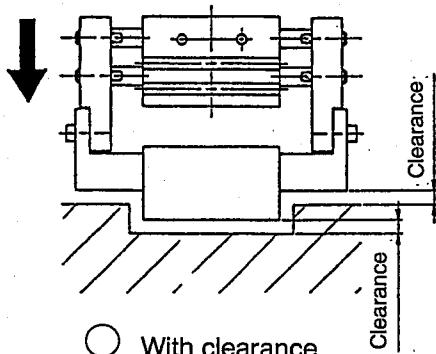

○ With clearance

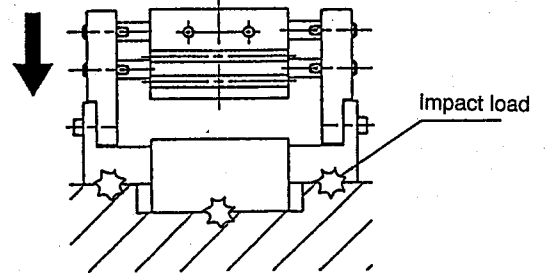

× Without clearance

- ④ Adjust the holding point so that excessive force will not be applied on fingers when inserting the work. Confirm that the gripper can operate without receiving any shock by testing with manual operation or low-speed operation.

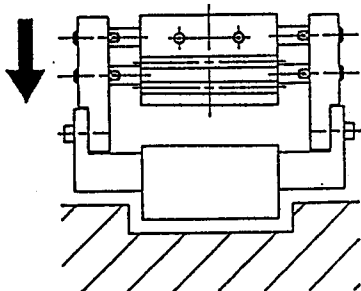

○ Holding point is adjusted

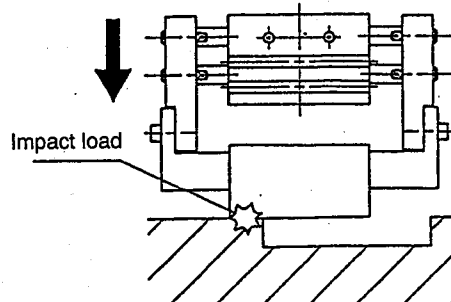

× Holding point is not adjusted

- ⑤ Control the opening/closing speed with the speed controller to avoid excessive high-speed operation. Continuous opening and closing at high speed may cause play or damage by inertia of finger and attachment, therefore install speed controller to avoid impact. Adjustment should be performed by connecting 2 pcs. of speed controllers at meter out control.

Applicable speed controller

Air gripper mounted type.....AS1200-M5, AS2200-01

Piping type.....AS1000, AS2000 series, AS1001F, AS2051F, etc.

3-5 Finger attachment

 Warning

Secure necessary space for maintenance space of

- ① Do not drop nor dent the gripper when mounting.
Slight deformation can cause inaccuracy or malfunction.
- ② Retract the piston rod not to be twisted while attachment is mounted to finger.

How to mount the attachment on fingers

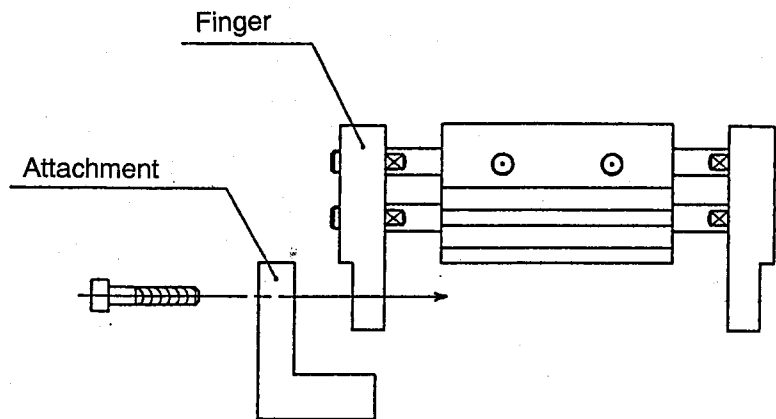

- ③ Nicks or dints on sliding surface of piston rod lead the breakage of bushing or packings and might cause malfunctioning or air leakage.
- ④ Tighten the screw within the specified torque range to mount the attachment.
The tightening with larger torque than specified range may cause malfunction, while the tightening with smaller torque may allow movement of holding position and dropping of work.
- ⑤ As for tightening torque for finger mounting bolt, see the table below.

Model	Bolt	Max. tightening torque N·m{kgf/cm}
MHL2-10D□	M4×0.7	1.4 {14}
MHL2-16D□	M5×0.8	2.8 {29}
MHL2-20D□	M6×1	4.8 {49}
MHL2-25D□	M8×1.25	12 {122}
MHL2-32D□	M10×1.5	24 {245}
MHL2-40D□	M12×1.75	42.2 {430}

3-6 Selection

⚠ Warning

- ① The work holding point R should be within the limit range.

When the overhang is larger for attachment mounting on finger, an excessive moment is applied to bushing, causing excessive play of fingers and exercising an adverse effect on the life, therefore holding point R should be within the range in catalogue of air gripper.

- ② Attachment should be designed as light and short as possible.

1. Long and heavy attachment increases the inertia force to open or close the fingers. It may cause unsteady movement of fingers and have an adverse effect on life.
2. Even if holding point remains within the limited range, make the attachment as light and short as possible.
3. Select the larger size gripper or use two or more grippers for one piece at once for handling long and large work.

- ③ Select the model whose holding force is sufficient against work weight.

Incorrect selection may lead to release of work etc.

Refer to "Effective holding force" and information to select the model by weight of work.

- ④ Do not use in applications where excessive external force or impact force may be applied to gripper.

It may cause malfunction.

Consult SMC with regard to any other applications.

- ⑤ Select the model taking the width of fingers between opening and closing points into consideration.

(In case of short width)

1. The holding condition becomes unsteady due to the unstable opening/closing width or the changeable work diameter.
2. When using the auto switch, malfunction may be caused. Refer to "Auto switch hysteresis" and set the stroke including the hysteresis length for sure. Especially, when using water proof improvement 2 color auto switch, stroke may be limited depending on set of detection lamp, therefore refer to "Auto switch hysteresis".

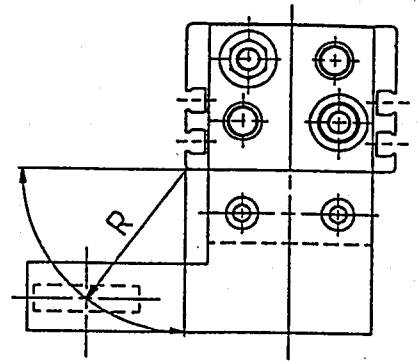

○ R is correct

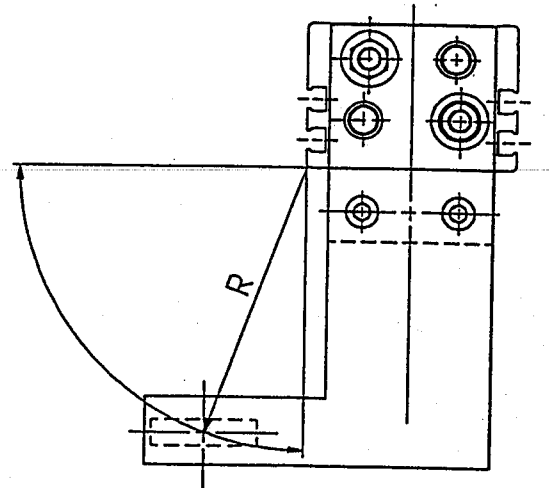

× R is too long

Holding position R

3-7 Installation and Setting of Auto Switch

Auto switch can be used in various ways depending on the number installed and the required detecting position.

1) Detection of work (External holding)

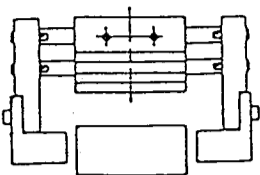
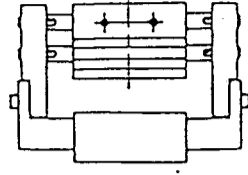
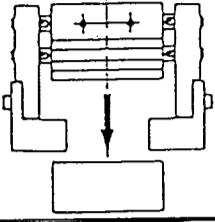
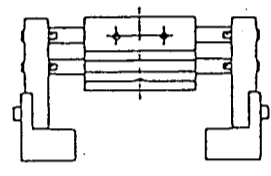
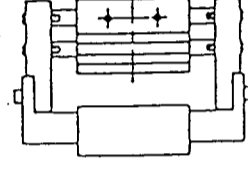
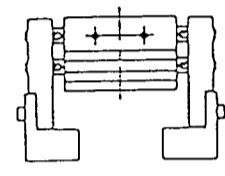
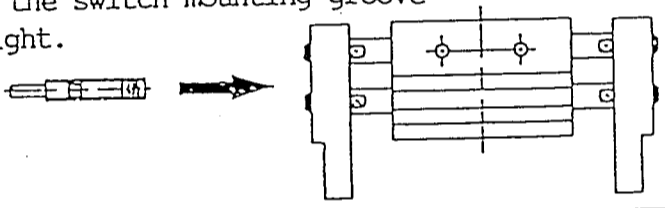
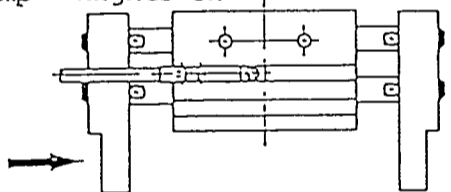
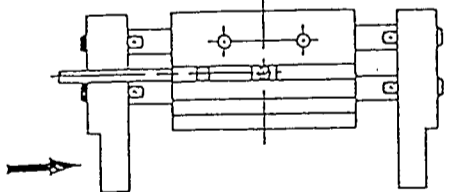
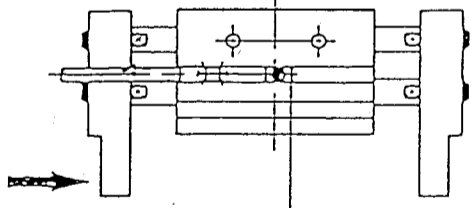
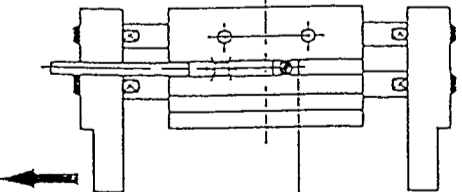
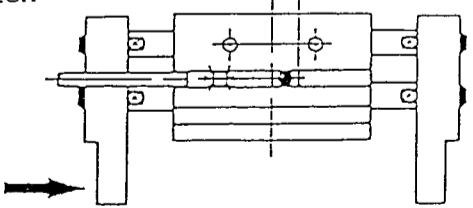
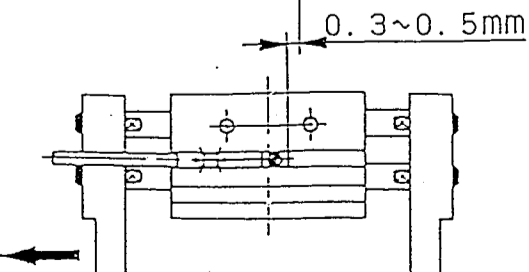
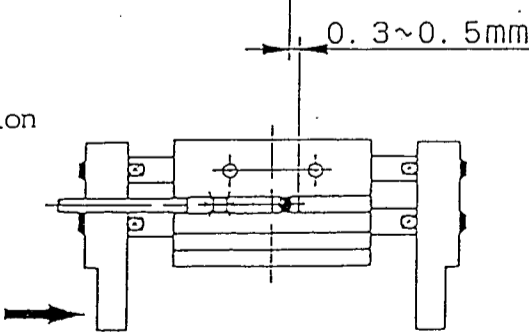
Detection samples	1. To make sure fingers return to the initial position.	2. To detect if the work is held.	3. To detect if the work is not held.	
Detection position	Fingers are fully opened 	The holding position of work. 	Fingers are fully closed 	
Operation of Auto Switch	Switch to turn ON at finger reset position (Lamp:operation)	Switch to turn ON at work holding position (Lamp:operation)	At work holding position (Normal operation): Turn OFF the switch (Lamp not lit) Work not held condition (Abnormal operation): Turn ON the switch (Lamp:operation)	
Combinations	1 Auto Switch should be used.	●	●	
	2 Auto Switches should be used.	●-----●	●-----●	
The procedure for setting the Auto Switch mounting position	1) Open fingers completely. 	1) Position fingers at the required work holding position. 	1) Close fingers completely. 	
	Connect the switch to the power supply, ensuring that the air supply remains turned off, and then set the Switch by the following procedure.	2) Insert the Auto Switch into the switch mounting groove in the direction as shown right. 		
3) Move the switch in the direction of the arrow until the indicator lamp "lights-on" 		3) Move the Switch in the direction of the arrow, and continue to move it 0.3~0.5mm past the "Light-on" position, and then fix it in that position.		
4) Continue to move the switch in the direction of the arrow until the indicator lamp "lights-off". 		The position of "Light-on" 		
5) Move the switch back in the opposite direction and fix it at the position 0.3~0.5mm past where the indicator lamp first "lights-on". 	The "Fix" position 			
				

Note) The work should be held at approximately the center of the finger stroke.

In the case that the work is held at approximately the end of the finger stroke, the combination of possible detections might be limited due to the hysteresis of the Auto Switch.

Auto switch can be used in various ways depending on the number installed and the required detecting position.

2) Internal holding

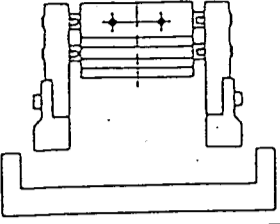
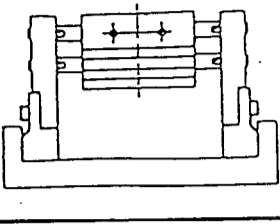
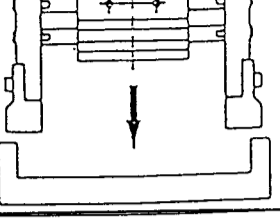
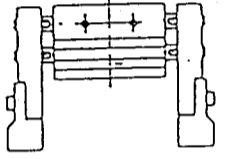
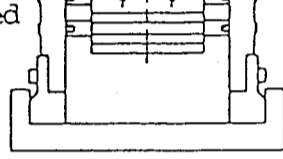
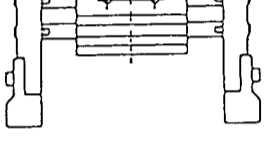
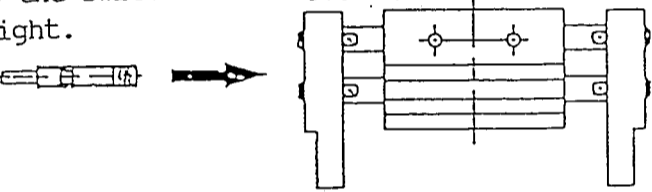
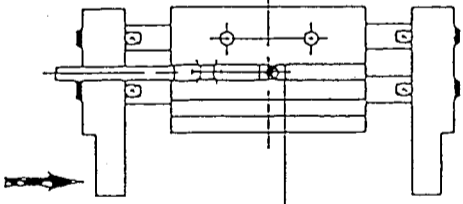
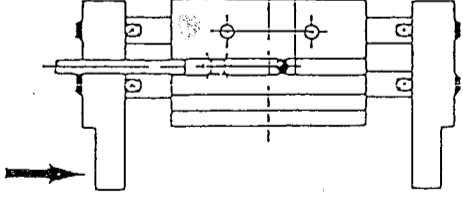
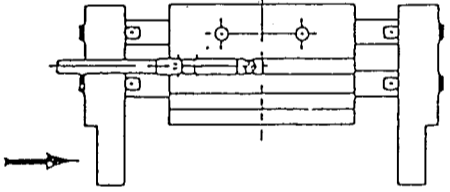
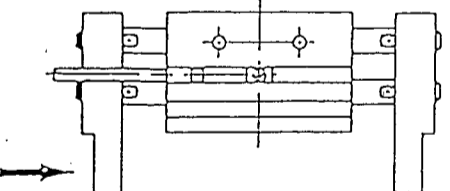
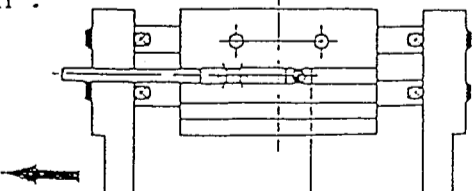
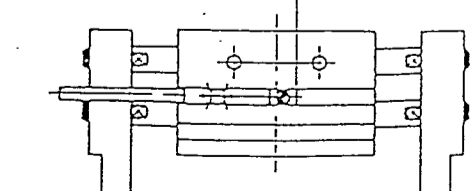
Detection samples	1. To make sure fingers return to the initial position.	2. To detect if the work is held.	3. To detect if the work is not held.
Detection position	Fingers are fully closed. 	The holding position of work. 	Fingers are fully opened. 
Operation of Auto Switch	Switch to turn ON at finger reset position (Lamp:operation)	Switch to turn ON at work holding position (Lamp:operation)	At work holding position (Normal operation): Turn OFF the switch (Lamp not lit) Work not held condition (Abnormal operation): Turn ON the switch (Lamp:operation)
Combinations	1. Auto Switch should be used.	●	
	2. Auto Switches should be used.	●—●	●
The procedure for setting the Auto Switch mounting position.	1) Close fingers completely. 	1) Position fingers at the required work holding position. 	1) Open fingers completely. 
	Connect the switch to the power supply, ensuring that the air supply remains turned off, and then set the Switch by the following procedure.	2) Insert the Auto Switch into the switch mounting groove in the direction as shown right. 	
	3) Move the Switch in the direction of the arrow, and continue to move it 0.3~0.5mm past the "Light-on" position, and then fix it in that position. The position of "Light-on"  The "Fix" position 	3) Move the switch in the direction of the arrow until the indicator lamp "lights-on".  4) Continue to move the switch in the direction of the arrow until the indicator lamp "lights-off".  5) Move the switch back in the opposite direction and fix it at the position 0.3~0.5mm past where the indicator lamp first "lights-on".  	

Note) The work should be held at approximately the center of the finger stroke.

In the case that the work is held at approximately the end of the finger stroke, the combination of possible detections might be limited due to the hysteresis of the Auto Switch.

② Setting method of Auto Switch

Insert auto switch into the switch mounting groove in the air chuck in the air gripper in the direction shown below, then tighten the attached switch mounting screw with a screw driver after setting the mounting position.

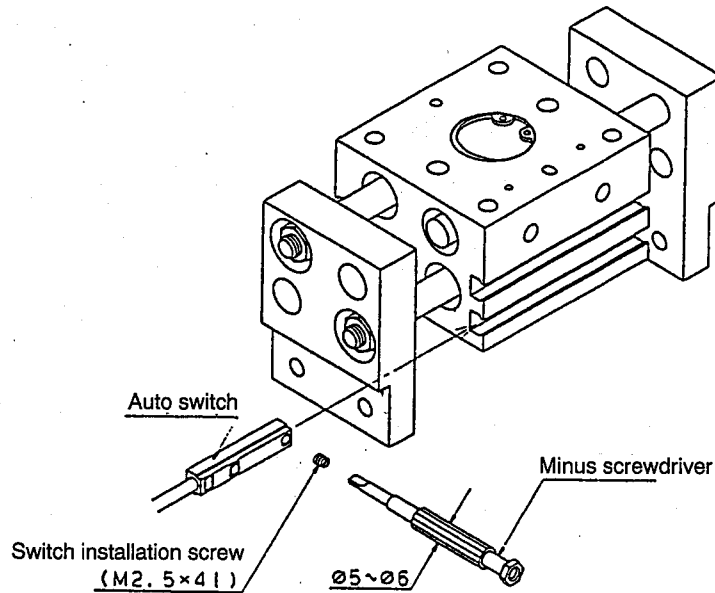

Note) Use a screwdriver with a grip diameter of 5 to 6 mm to tighten the auto-switch mounting screw. The tightening torque should be about 0.05~0.1N·m. When you begin to feel that the screw is being tightened, turn it further by 90°.

③ Auto Switch Hysteresis

The hysteresis of the auto switch are shown in the table below.

Refer to them for controlling the switch location.

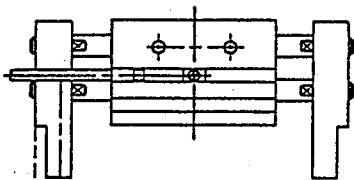

Auto Switch Part No.	D-Y59 ^A _B D-Y69 ^A _B	D-Y7 ^N _B W	D-Y7 ^N _B WV	D-Y7BA
MHL2-10D□	0.8	0.6	0.7	0.5
MHL2-16D□	0.5	0.3	0.3	0.2
MHL2-20D□	0.5	0.2	0.3	0.2
MHL2-25D□	0.2	0.2	0.2	0.1
MHL2-32D□	0.4	0.7	0.7	0.4
MHL2-40D□	0.2	0.7	0.6	0.4

④ Handling instruction

1. Do not nicks or dint the sliding surface of piston rod. It may lead the breakage of packings or air leakage.
2. Although the mounting surface of the air gripper is plated with hard anodic oxide coating, please be sure not to nick or dint on the mounting surface of air gripper. It may cause such as play at mounting or inaccuracy.

3-8 Piping

① Preparation before piping

Thoroughly air blow (brushing) or clean to remove chips, cutting oil, and dust in the pipe.

② How to wrap seal tape

When installing piping and fittings, care should be taken to avoid entering of chips from piping threads and seal materials into the product. In addition, when wrapping seal tape, please leave 1.5~2 threads uncovered on the pipe end.

③ Operating air

Air supplied to the cylinder should be filtered off by using SMC made AF series air filter, and operate pressure reduced air to the specified setting pressure by such as AR series regulator.

4 Maintenance • Inspection

Warning

4-1 Maintenance • Inspection

① Do not enter the transfer line nor put the object.

It may cause unexpected accidents.

② Do not enter your hands between finger and attachment.

It may cause unexpected accidents.

③ Confirm that no work is held by fingers before releasing the compressed air to remove the gripper from the line.

④ Do not disassemble or modify.

4-2 Parts List

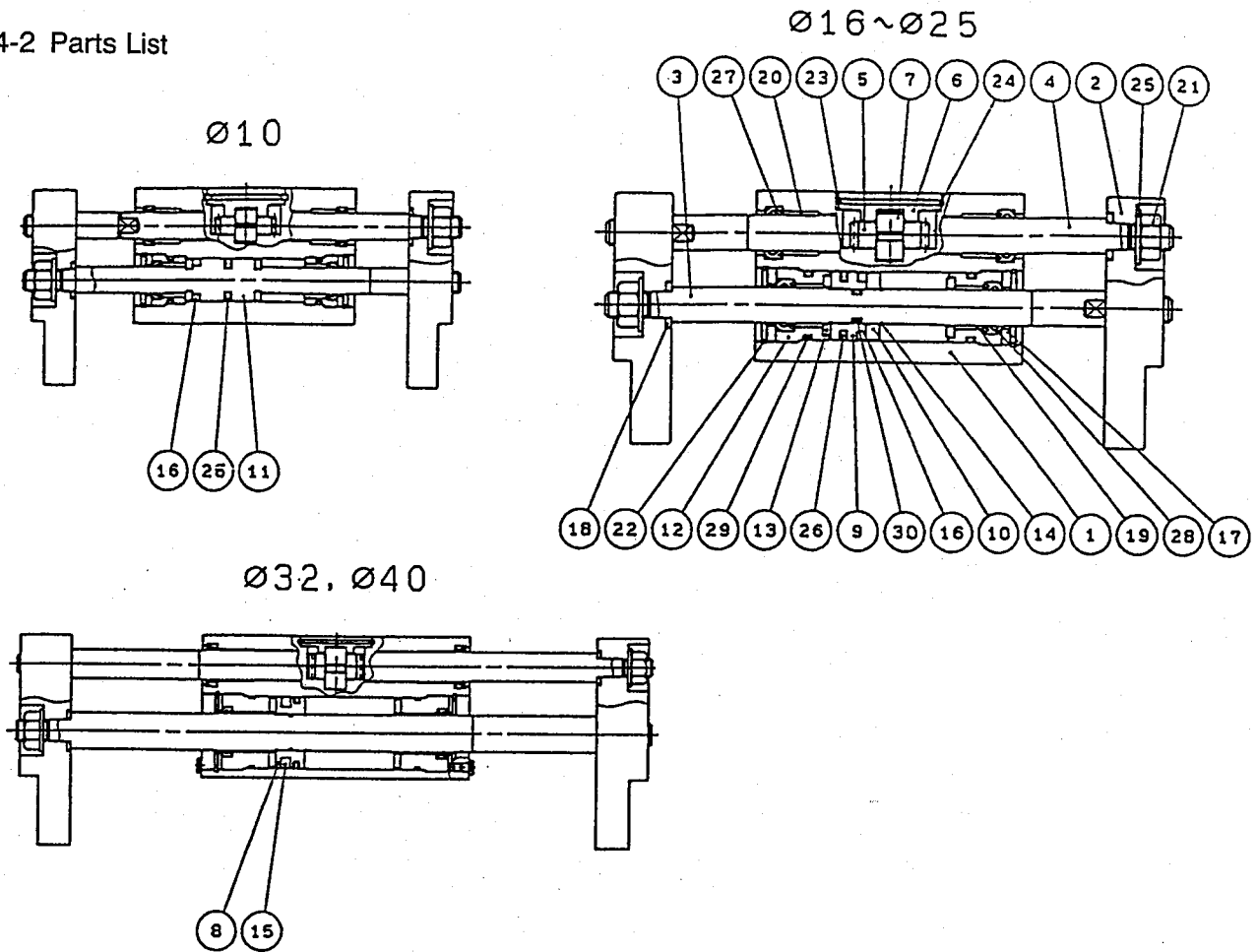

Parts List

No.	Description	Material	Note	No.	Description	Material	Note
1	Body	Aluminum alloy	Hard alumite treatment	15	Rubber magnet	Synthetic rubber	
2	Finger	Aluminum alloy	Hard alumite treatment	16	Magnet	Magnet material	Nickel plating
3	Piston rod	Stainless steel		17	Rod packing cover B	Cold-rolled steel	Electrolysis nickel plating
4	Rack	Stainless steel		18	Washer	Stainless steel	Nitriding
5	Pinion	Carbon steel		19	Bearing	Oil containing polyacetal with back metal	
6	Pinion cover	Carbon steel	Heat treatment· Electrolysis nickel plating	20	Bearing	Oil containing polyacetal with back metal	
7	Pinion shaft	Stainless steel	Nitriding	21	U nut	Carbon steel	Nickel plating
8	Piston	Brass		22	R-shape snap ring	Carbon steel	Nickel plating
9	Piston A	Brass		23	C-shape snap ring	Carbon steel	Nickel plating
10	Piston B	Brass		24	Wave washer	Steel for spring	Phosphate coating
11	Piston A	Stainless steel		25	Conical spring washer	Carbon steel	Nickel plating
12	Rod cover	Aluminum alloy	Chromate treatment				
13	Damper	Urethane rubber					
14	Clip	Stainless steel spring wire					

Packing List

	Description	Material	Parts No.					
			MHL2-10D□	MHL2-16D□	MHL2-20D□	MHL2-25D□	MHL2-32D□	MHL2-40D□
26	Packing set	NBR	MHL10-PS	MHL16-PS	MHL20-PS	MHL25-PS	MHL32-PS	MHL40-PS
27								
28								
29								
30								

4-3 Piston Ass'y replacement procedure

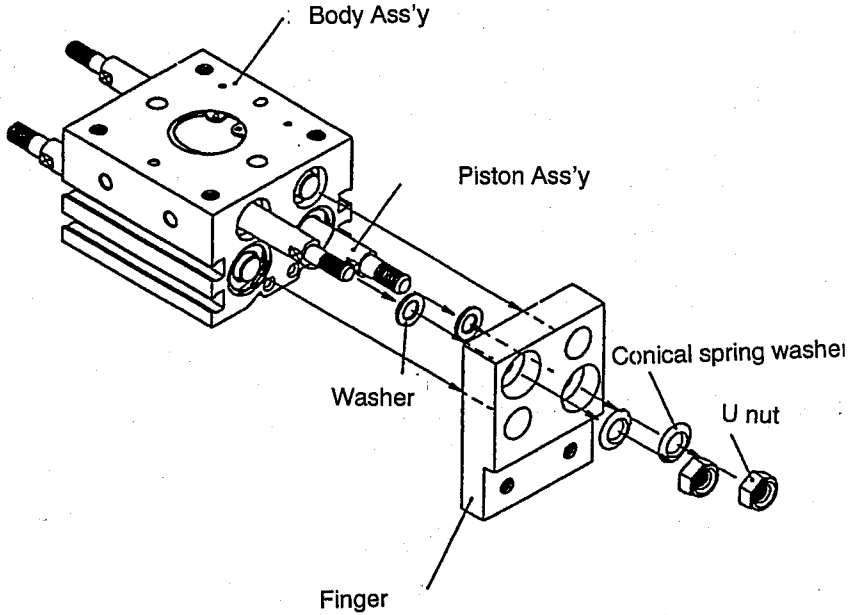
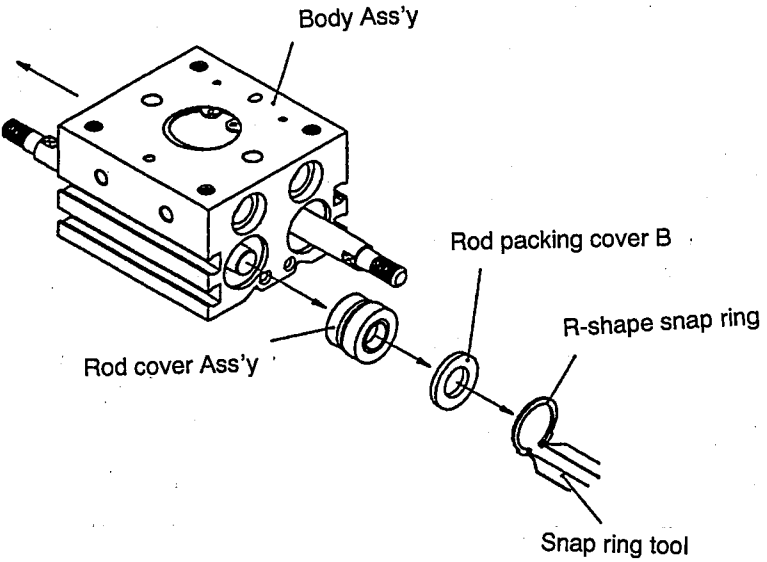
Procedure	Contents of procedure	Illustration
1	<p>① Loosen U nut, then remove conical spring washer, finger, and washer.</p>	
2	<p>① Remove R-shape snap ring using snap ring tool. ② Remove rod packing cover B and rod cover Ass'y. ③ Pull out piston Ass'y.</p>	
3	Replace piston Ass'y	

4-4 Replacement procedure of packing set

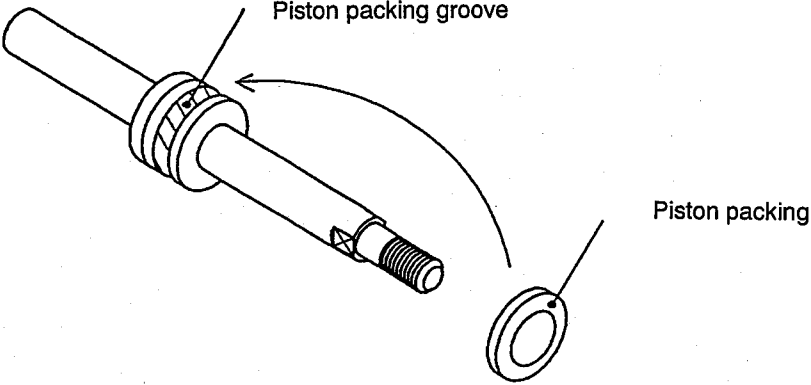
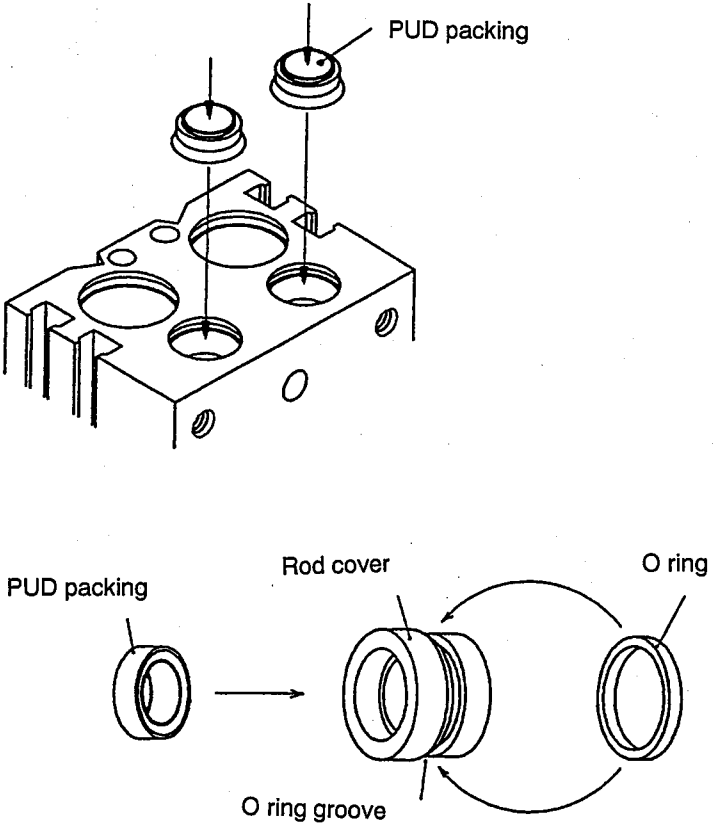
Procedure	Contents of procedure	
1	<p>① Replacement of piston packing</p>	
2	<p>① Replacement of rod packing for body rack</p> <p>② Replacement of O ring and rod packing for rod cover Ass'y</p>	
3	Replace packing	

Revision history

SMC Corporation

4-14-1, Sotokanda, Chiyoda-ku, Tokyo 101-0021 JAPAN

Tel: + 81 3 5207 8249 Fax: +81 3 5298 5362

URL <https://www.smcworld.com>