



Operation Manual

PRODUCT NAME

Parallel Type Air Gripper

MODEL / Series / Product Number

MHZ2-6□
MHZJ2-6□
MHZA2-6□
MHZAJ2-6□

SMC Corporation

Contents

Safety Instructions

1. Product Specifications

1-1. Specifications

2. Operating method or operation

2-1. Design precautions

2-2. Selection

2-3. Mounting

2-4. Air supply

2-5. Piping

2-6. Operating environment

2-7. Lubrication

3. Maintenance

3-1. Precautions

3-2. Replacement of Dust Cover (MHZJ2 / MHZAJ2 Only)

3-3. Construction / Parts list, seal list · · · MHZ2-6□

3-4. Construction / Parts list, seal list · · · MHZJ2-6□

3-5. Construction / Parts list, seal list · · · MHZA2-6*□

3-6. Construction / Parts list, seal list · · · MHZAJ2-6□



Safety Instructions

These safety instructions are intended to prevent hazardous situations and/or equipment damage. These instructions indicate the level of potential hazard with the labels of “Caution,” “Warning” or “Danger.” They are all important notes for safety and must be followed in addition to International Standards (ISO/IEC)*1), and other safety regulations.

*1) ISO 4414: Pneumatic fluid power -- General rules relating to systems.

ISO 4413: Hydraulic fluid power -- General rules relating to systems.

IEC 60204-1: Safety of machinery -- Electrical equipment of machines .(Part 1: General requirements)

ISO 10218: Manipulating industrial robots -Safety.

etc.



Caution

Caution indicates a hazard with a low level of risk which, if not avoided, could result in minor or moderate injury.



Warning

Warning indicates a hazard with a medium level of risk which, if not avoided, could result in death or serious injury.



Danger

Danger indicates a hazard with a high level of risk which, if not avoided, will result in death or serious injury.

Warning

1. The compatibility of the product is the responsibility of the person who designs the equipment or decides its specifications.

Since the product specified here is used under various operating conditions, its compatibility with specific equipment must be decided by the person who designs the equipment or decides its specifications based on necessary analysis and test results.

The expected performance and safety assurance of the equipment will be the responsibility of the person who has determined its compatibility with the product.

This person should also continuously review all specifications of the product referring to its latest catalog information, with a view to giving due consideration to any possibility of equipment failure when configuring the equipment.

2. Only personnel with appropriate training should operate machinery and equipment.

The product specified here may become unsafe if handled incorrectly.

The assembly, operation and maintenance of machines or equipment including our products must be performed by an operator who is appropriately trained and experienced.

3. Do not service or attempt to remove product and machinery/equipment until safety is confirmed.

1. The inspection and maintenance of machinery/equipment should only be performed after measures to prevent falling or runaway of the driven objects have been confirmed.

2. When the product is to be removed, confirm that the safety measures as mentioned above are implemented and the power from any appropriate source is cut, and read and understand the specific product precautions of all relevant products carefully.

3. Before machinery/equipment is restarted, take measures to prevent unexpected operation and malfunction.

4. Contact SMC beforehand and take special consideration of safety measures if the product is to be used in any of the following conditions.

1. Conditions and environments outside of the given specifications, or use outdoors or in a place exposed to direct sunlight.

2. Installation on equipment in conjunction with atomic energy, railways, air navigation, space, shipping, vehicles, military, medical treatment, combustion and recreation, or equipment in contact with food and beverages, emergency stop circuits, clutch and brake circuits in press applications, safety equipment or other applications unsuitable for the standard specifications described in the product catalog.

3. An application which could have negative effects on people, property, or animals requiring special safety analysis.

4. Use in an interlock circuit, which requires the provision of double interlock for possible failure by using a mechanical protective function, and periodical checks to confirm proper operation.



Safety Instructions

Caution

The product is provided for use in manufacturing industries.

The product herein described is basically provided for peaceful use in manufacturing industries.

If considering using the product in other industries, consult SMC beforehand and exchange specifications or a contract if necessary.

If anything is unclear, contact your nearest sales branch.

Limited warranty and Disclaimer/Compliance Requirements

The product used is subject to the following "Limited warranty and Disclaimer" and "Compliance Requirements".

Read and accept them before using the product.

Limited warranty and Disclaimer

1. The warranty period of the product is 1 year in service or 1.5 years after the product is delivered, whichever is first.*2)

Also, the product may have specified durability, running distance or replacement parts. Please consult your nearest sales branch.

2. For any failure or damage reported within the warranty period which is clearly our responsibility, a replacement product or necessary parts will be provided.

This limited warranty applies only to our product independently, and not to any other damage incurred due to the failure of the product.

3. Prior to using SMC products, please read and understand the warranty terms and disclaimers noted in the specified catalog for the particular products.

*2) Vacuum pads are excluded from this 1 year warranty.

A vacuum pad is a consumable part, so it is warranted for a year after it is delivered.

Also, even within the warranty period, the wear of a product due to the use of the vacuum pad or failure due to the deterioration of rubber material are not covered by the limited warranty.

Compliance Requirements

1. The use of SMC products with production equipment for the manufacture of weapons of mass destruction(WMD) or any other weapon is strictly prohibited.

2. The exports of SMC products or technology from one country to another are governed by the relevant security laws and regulation of the countries involved in the transaction. Prior to the shipment of a SMC product to another country, assure that all local rules governing that export are known and followed.

Caution

SMC products are not intended for use as instruments for legal metrology.

Measurement instruments that SMC manufactures or sells have not been qualified by type approval tests relevant to the metrology (measurement) laws of each country.

Therefore, SMC products cannot be used for business or certification ordained by the metrology (measurement) laws of each country.

1. Product Specifications

1-1. Specifications

Specifications

Model No.		MHZ2-6□	MHZJ2-6□	MHZA2-6□	MHAJ2-6□
Cylinder inside diameter (mm)		6			
Fluid		Air			
Operating pressure (Mpa)	Double acting: D		0.15 to 0.7		
	Single acting	Normally open: S	0.3 to 0.7		
Normally closed: C					
Ambient and fluid temperature (°C)		-10 to 60			
Repeatability (mm)		+/-0.01			
Maximum operating frequency (c.p.m.)		180			
Lubrication		Lubrication not required.			
Action		Double acting, single acting			
Note 1) Gripping force per finger Effective value (N)	D	O.D. External gripping force	3.3		
		I.D. Internal gripping force	6.1		
	S	O.D. External gripping force	1.9		
		I.D. Internal gripping force	3.7		
Open/close stroke (Both sides) (mm)		4			
Note 2) Weight (g)		27	28	26	27

Note 1) Values based on pressure of 0.5 MPa, gripping point L=20 mm, at center of stroke.

Note 2) Values excluding weight of auto switch.

2. Operating method or operation

2-1. Design precautions

Warning

1. The product is designed for use only in compressed air systems. Do not operate at pressures or temperatures, etc., beyond the range of specifications, as this can cause damage or malfunction. (Refer to the specifications.)
Please contact SMC if using for fluids other than compressed air. We do not guarantee against any damage if the product is used outside of the specification.
2. Take safety measures (e.g. mounting protective covers) when workpieces pose a danger of fingers being caught in a gripper, etc.
3. There is a danger of workpieces dropping if there is a decrease in gripping force due to a drop in circuit pressure caused by a power failure, etc. It is necessary to take measures such as drop prevention so that injury and damage to machinery or equipment can be prevented.
4. If the product is used for the purpose other than the transportation of a workpiece such as positioning or clamping, please consult SMC.

2-2. Selection

Warning

1. The gripping point should be set within the limited range.
When the gripping point distance becomes large, the gripper attachment applies an excessively large load to the gripper sliding section, and causes adverse affects on the life of the gripper. Refer to the catalog for details.

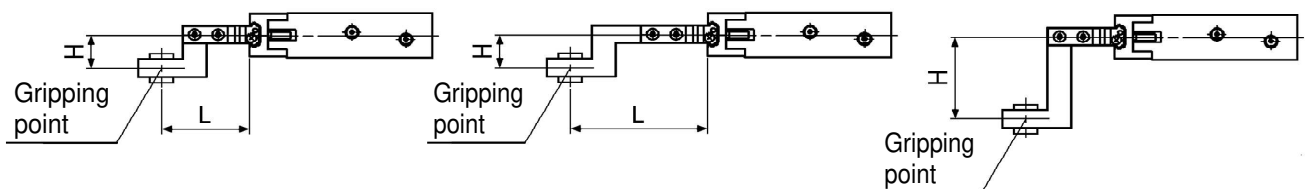

Good: "L" and "H" are appropriate

Not good: "L" is too long

Not good: "H" is too long

2. Attachments should be designed to be as light and short as possible.

- (1) A long or heavy attachment increases the inertia force required to open or close the fingers. This may cause unsteady movement of fingers and have an adverse affect on the life of the gripper.
- (2) Design the attachment as short and light as possible even if the gripping point is within the limited range. Refer to the catalog for details.

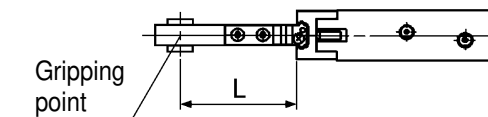

- (3) Select a larger size gripper or used two or more grippers for handling a long and/or large workpiece.

3. Provide a runoff space in the attachment when using with a small or thin workpiece.
If a runoff space is not provided within the finger part, gripping becomes unsteady, and it may lead to gripping failure or slippage.

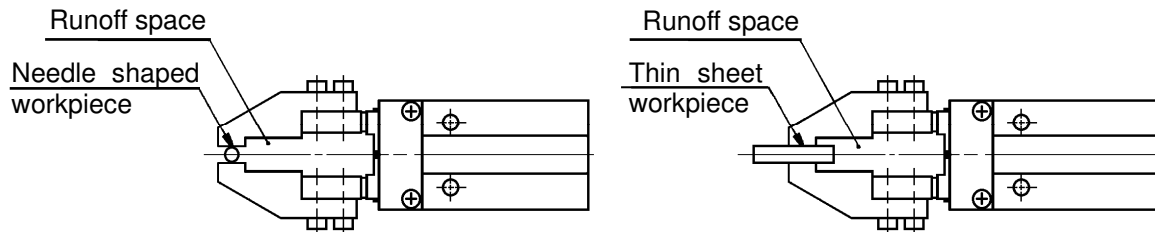

4. Select a model whose gripping force is compatible with the workpiece mass.
Incorrect selection may lead to the dropping of a workpiece, etc. Refer to the model selection criteria of each series for the effective gripping force and the workpiece mass.
5. Do not use the product in applications where excessive external force or impact force is applied. It may cause product failure. Please consult with SMC if necessary.
6. Select a model having a sufficient working finger opening/closing width.
< In case of insufficient width >
- (1) Gripping becomes unsteady due to variations in opening/closing width or workpiece diameter.
 - (2) When using an auto switch, the detection may not be reliable. Refer to the Auto Switch Hysteresis section and set the stroke including the hysteresis length for a reliable switch function. When using the water resistant 2-color indicator auto switch, the gripper stroke may be limited by the setting of the indicator color during detection.
7. Please consult with SMC regarding a single acting, spring force only grip type.
In some cases, this can cause unstable gripping or return malfunction, due to faulty operation, etc.

2-3. Mounting

Warning

1. Install and operate the product only after reading the Operation Manual carefully and understanding its contents. Also, keep the manual where it can be referred to as necessary.
2. Allow sufficient space for maintenance and inspection.
3. Do not drop or hit the product when mounting to avoid scratches and dents. Even slight deformation can cause the deterioration of accuracy and operation failure.
4. Tighten the mounting screws of the attachment with the specified torque. Tightening the screws with a higher torque than the maximum may cause malfunction. In addition, tightening the screws with a lower torque can cause the displacement of the mounting position or in extreme conditions, detaching of the work piece.

Mounting attachment to the finger

The attachment should be mounted with the torque specified in the following table by screwing the bolt into the female mounting thread of the finger.

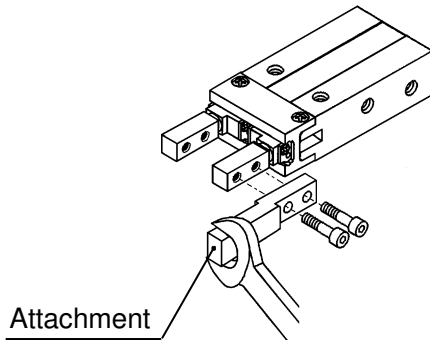

Model No	Screw	Max. tightening torque (N · m)
MHZ2-6□	M2x0.4	0.15
MHZJ2-6□		
MHZA2-6□		
MHZAJ2-6□		

5. Tighten the screw within the specified torque range when mounting the air gripper. Tightening with a torque above the limit can cause malfunction, while insufficient tightening can cause slippage and dropping.

Mounting Gripper

Axial mounting (Body tapped)

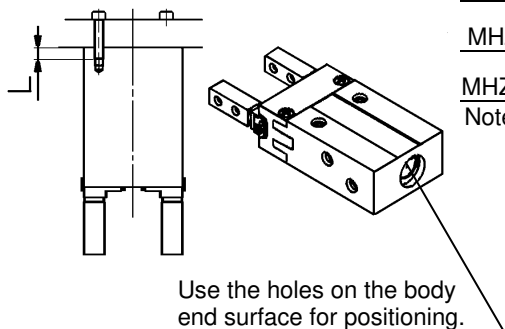

Model No.	Screw	Max. tightening torque (N · m)	Max. thread depth (mm)	Hole diameter (mm)	Hole depth (mm)
MHZA2-6□	M2×0.4	0.15	4.5	φ7H8(+0.022/0)	1.5
MHZAJ2-6□					

Note) Axial mounting type is not available for MHZ2-6□ and MHZJ2-6□.

Vertical mounting (Body tapped)

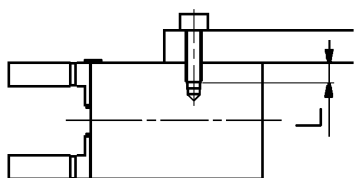

Model No.	Screw	Max. tightening torque (N · m)	Maximum screw-in depth (mm)
MHZA2-6□	M2x 0.4	0.15	4
MHZAJ2-6□			

Note) Except MHZ2-6□ and MHZJ2-6□.

Side mounting (Body tapped)

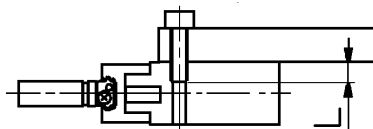

Model No.	Screw	Max. tightening torque (N · m)	Maximum screw-in depth (mm)
MHZ2-6□	M3 x 0.5	0.88	10
MHZJ2-6□			
MHZA2-6□			
MHZAJ2-6□			

Horizontal mounting (Body tapped)

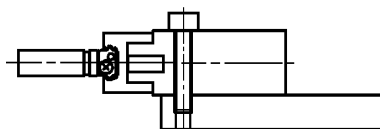

Model No.	Screw	Max. tightening torque (N · m)
MHZ2-6□	M2.5x0.45	0.49
MHZJ2-6□		
MHZA2-6□		
MHZAJ2-6□		

 **Caution**

1. Avoid twisting the gripper when mounting an attachment.

Any damage to the gripper may cause malfunction and reduce the accuracy.

2. Avoid external force to fingers.

Fingers may be damaged by a continual lateral or impact load. Provide clearance to prevent the workpiece or the attachment from striking against any object at the stroke end.

1. Stroke end when fingers are opened

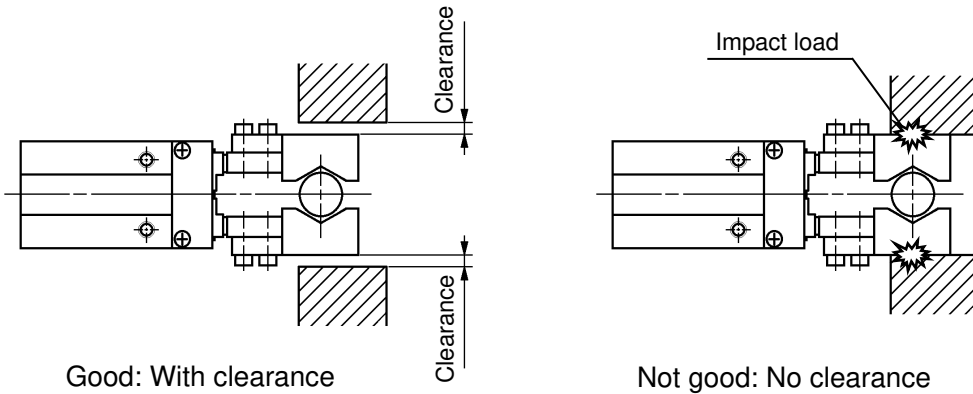

2. Stroke end when gripper is moving

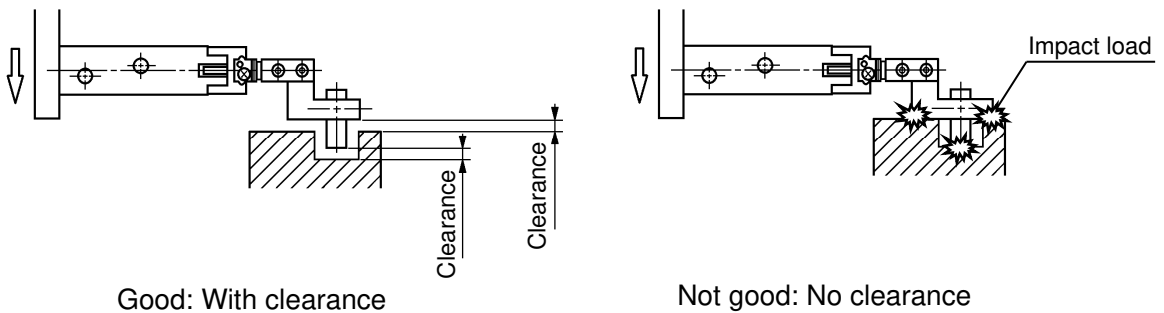

3. When turning over

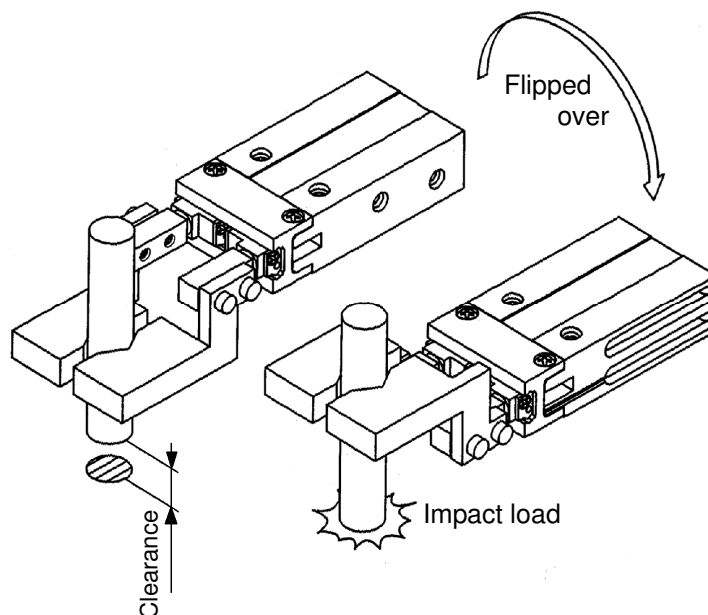

3. Adjust the gripping point so that an excessive force will not be applied to the fingers when inserting a workpiece.

Confirm that the gripper can operate without receiving any shock by testing it in manual

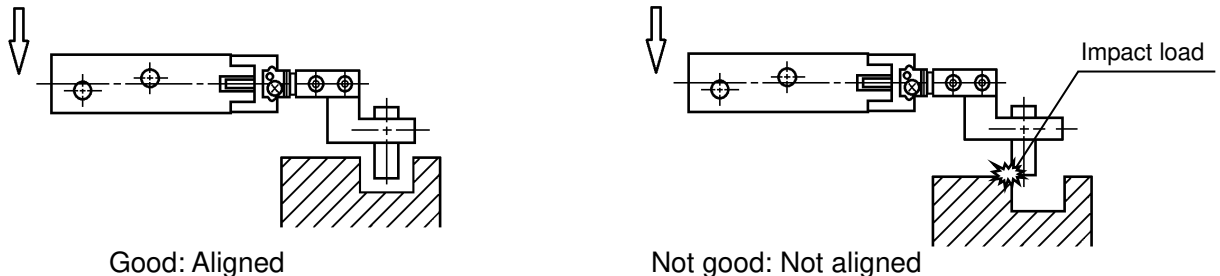

4. Control the opening/closing speed with the speed controller to avoid excessive high speed operation.

If the finger opening/closing speed is greater than necessary, impact forces on the fingers and other parts will increase. This can cause a loss of repeatability when gripping a workpiece and have an adverse effect on the life of the gripper unit.

Example of Using SMC's Speed Controller

<Applicable Speed controller>

Air gripper mounted type: AS1211F-M3, AS1201F-M5, etc.

Piping type: AS1000 series, AS1002F, etc.

2-4. Air supply

Warning

1. Please contact SMC when using the product in applications other than with compressed air.
2. Compressed air containing a large amount of condensate can cause malfunction of pneumatic equipment. An air dryer or water droplet separator should be installed upstream from filters.
3. If condensate in the drain bowl is not emptied on a regular basis, the condensate will overflow and allow it to enter the compressed air lines. This will cause a malfunction of pneumatic equipment. If the drain bowl is difficult to check and remove, installation of a drain bowl with an auto drain option is recommended.
4. Use clean air.

Do not use compressed air that contains chemicals, synthetic oils including organic solvents, salt or corrosive gases, etc., as it can cause damage or malfunction.

For detailed information regarding the quality of the compressed air described above, refer to SMC's "Air Cleaning Systems".

Caution

1. When extremely dry air is used as the fluid, degradation of the lubrication properties inside the equipment may occur, resulting in reduced reliability (or reduced service life) of the equipment. Please consult with SMC.
2. Install an air filter.
Install an air filter upstream near the valve. A filtration degree of 5µm or less should be selected.
3. Install an aftercooler, air dryer or drain catch before the filter and take appropriate measures.
Compressed air that contains excessive foreign material may cause malfunction of valves and other pneumatic equipment.
Install an aftercooler, air dryer or drain catch before the filter and take appropriate measures.
4. Use the product within the specified fluid and ambient temperature range.
When operating at temperatures 5°C or lower, water in the circuit may freeze and cause breakage of seals or malfunction. Measures should be taken to prevent freezing.
For detailed information regarding the quality of the compressed air described above, refer to SMC's "Air Cleaning Systems".

2-5. Piping

Caution

1. Refer to the Fittings and Tubing Precautions (Best Pneumatics) for handling one touch fittings.
2. Before piping
Before piping is connected, flush thoroughly with air or wash to remove chips, cutting oil and other debris from inside the pipe.

2-6. Operating environment

Warning

1. Do not use in an environment where corrosive gases, chemicals, sea water, water or steam are present.
Refer to the construction drawings regarding the air chuck materials.
2. Do not use in direct sunlight.
3. Do not operate in a location subject to vibration or impact.
4. Do not mount the product in locations where it is exposed to radiant heat.
5. Do not use this product in an area that is dusty, or in an environment in which water or oil splashes on the cylinder.

2-7. Lubrication

Caution

1. The non-lube type air gripper is lubricated at the factory, and can be used without any further lubrication.
If a lubricant is used in the system, use turbine oil Class 1 (with no additive) ISO VG32. Furthermore, once lubrication is applied, it must be continued.
If lubrication is later stopped, malfunction can occur due to loss of the original lubricant. Refer to the Material Safety Data Sheet (MSDS) of the hydraulic fluid when supplying the fluid.

3. Maintenance

3-1. Precautions

Warning

1. Maintenance should be performed according to the procedure indicated in the Operation Manual.
If handled improperly, malfunction and damage of machinery of equipment may occur.
2. If handled improperly, compressed air can be dangerous. Assembly, handling, repair and element replacement of pneumatic systems should be performed by a knowledgeable and experienced person.
3. Remove drainage moisture from air filters regularly.
4. When components are removed, first confirm that measures are in place to prevent any workpieces from dropping, run-away of equipment, etc. Then cut off the supply pressure and electric power, and exhaust all compressed air from the system using the residual pressure release function.
Turn off the power supply, stop the air supply and exhaust all compressed air from the system.
5. Do not allow people to enter or place objects in the carrying path of the air gripper.
This may cause an injury or accident.
6. Do not put hands, etc. in between the air gripper fingers or attachments.
This may cause an injury or accident.
7. When removing the air gripper, first confirm that no workpieces are being held and then release the compressed air before removing the air gripper.
If a workpiece is still being held, there is a danger of it being dropped.

3-2. Replacement of Dust Cover

< Removal of Dust Cover >

1. Hold the shaded regions indicated in the picture () of the cover. Remove the dust cover from the body groove carefully.
2. When the bead of the dust cover is separated from the body groove, pull the shaded part in direction of the finger.
3. When all the bead of the dust cover is out of the body groove, pull the cover in direction shown by arrow to remove it from the air gripper.

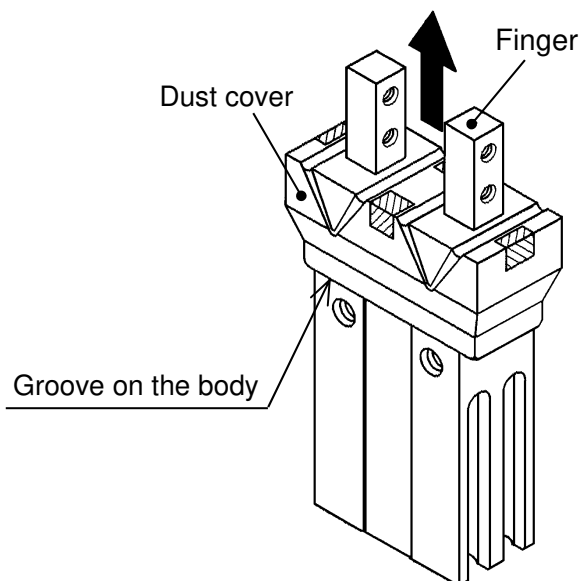

< Mounting of Dust Cover >

1. Put the dust cover on the finger.
2. Attach the dust cover to the groove of the finger.
3. Push the bead of the dust cover into the hole in the body groove.

Note: Be careful not to tear the dust cover during mounting or removal of the dust cover. Also, be careful not to twist the finger.

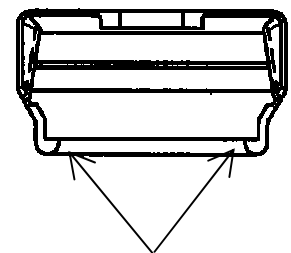

The bead of the dust cover
Cross section for dust cover

3-3. Construction / Parts list, seal list MHZ2-6□

Double acting / Finger open

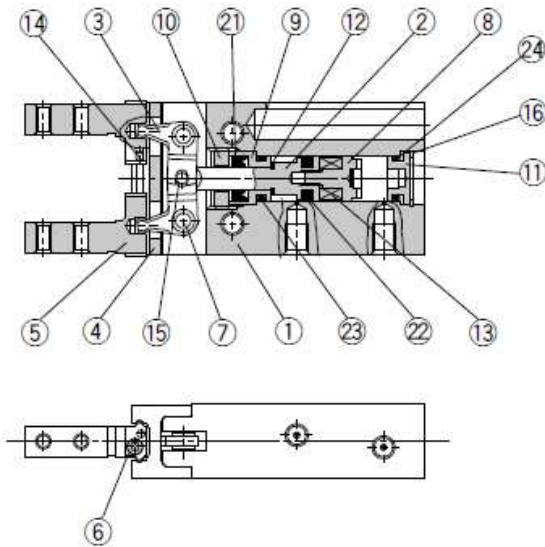

Single acting / Normal open

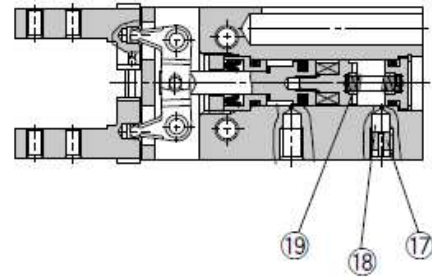

Single acting / Normal closed

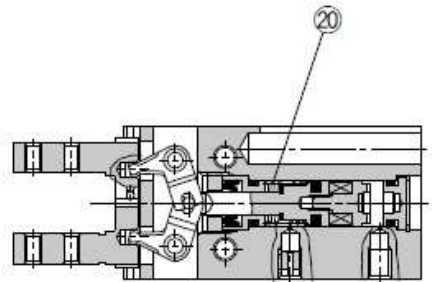

Double acting / Finger closed

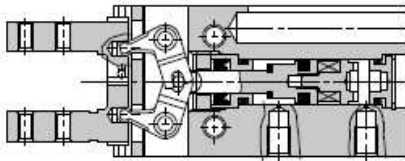

Components

No.	Description	Material	Remarks
1	Body	Aluminum alloy	Hard anodizing
2	Piston	Stainless steel	
3	Lever	Stainless steel	Heat treatment
4	Guide	Stainless steel	Heat treatment
5	Finger	Stainless steel	Heat treatment
6	Roller stopper	Stainless steel	
7	Lever shaft	Stainless steel	Nitriding
8	Magnet holder	Stainless steel	
9	Holder	Brass	Electroless nicked plated
10	Holder lock	Stainless steel	
11	Cap	Aluminum alloy	Clear anodized
12	Bumper	Urethane rubber	
13	Magnet	—	Nickel plated

Components

No.	Description	Material	Remarks
14	Steel ball	High carbon chromium bearing steel	Heat treatment
15	Needle roller	High carbon chromium bearing steel	Heat treatment
16	Type C retaining ring	Carbon steel	Phosphate coated
17	Exhaust plug	Brass	Electroless nickel plating
18	Exhaust filter	Polyvinyl formal	
19	N.O. spring	Stainless steel wire for spring	
20	N.C. spring	Stainless steel wire for spring	
21	Rod seal	NBR	
22	Piston seal	NBR	
23	Gasket	NBR	
24	Gasket	NBR	

Replacement parts

Description	MHZ2-6□
Seal kit	Please contact SMC to replace the seal kit, finger assembly and piston assembly.
Finger assembly	
Piston assembly	

3-4. Construction / Parts list, seal list MHZJ2-6□

Double acting / Finger open

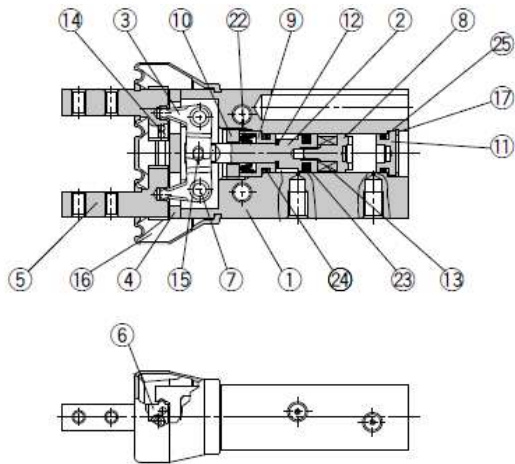

Single acting / Normal open

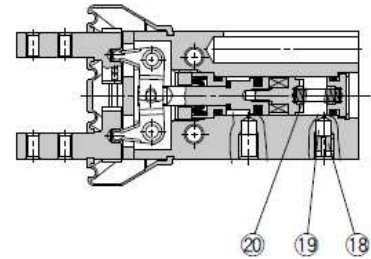

Single acting / Normal closed

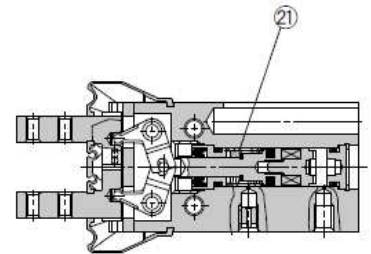

Double acting / Finger closed

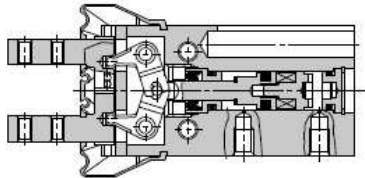

Components

No.	Description	Material	Remarks
1	Body	Aluminum alloy	Hard anodizing
2	Piston	Stainless steel	
3	Lever	Stainless steel	Heat treatment
4	Guide	Stainless steel	Heat treatment
5	Finger	Stainless steel	Heat treatment
6	Roller stopper	Stainless steel	
7	Lever shaft	Stainless steel	Nitriding
8	Magnet holder	Stainless steel	
9	Holder	Brass	Electroless nicked plated
10	Holder lock	Stainless steel	
11	Cap	Aluminum alloy	Clear anodized
12	Bumper	Urethane rubber	
13	Magnet	—	Nickel plated
14	Steel ball	High carbon chromium bearing steel	Heat treatment
15	Needle roller	High carbon chromium bearing steel	Heat treatment

Components

No.	Description	Material	Remarks
16	Dust cover	CR	Chloroprene rubber
		FKM	Fluororubber
		Si	Silicone rubber
17	Type C retaining ring	Carbon steel	Nickel plating
18	Exhaust plug	Brass	Electroless nickel plating
19	Exhaust filter	Polyvinyl formal	
20	N.O. spring	Stainless steel wire for spring	
21	N.C. spring	Stainless steel wire for spring	
22	Rod seal	NBR	
23	Piston seal	NBR	
24	Gasket	NBR	
25	Gasket	NBR	

Replacement parts

Description		MHZJ2-6□	
Seal kit		Please contact SMC to replace the seal kit, finger assembly and piston assembly.	
Finger assembly			
Piston assembly			
Dust cover	Material	CR	MHZJ2-J6
		FKM	MHZJ2-J6F
		Si	MHZJ2-J6S

3-5. Construction / Parts list, seal list MHZA2-6□

Double acting / Finger open

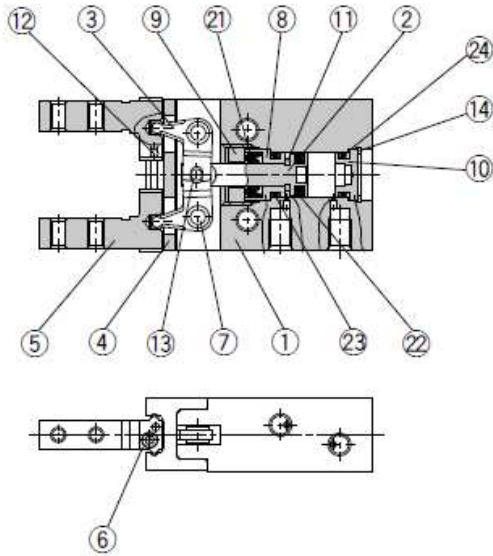

Single acting / Normal open

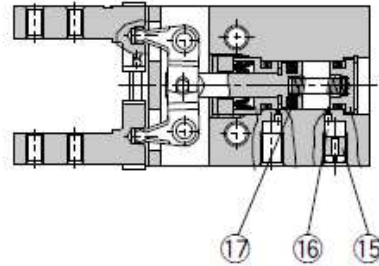

Single acting / Normal closed

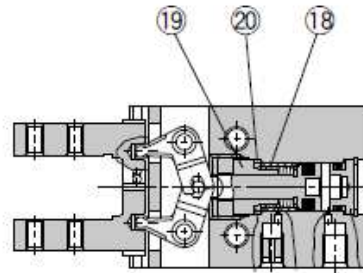

Double acting / Finger closed

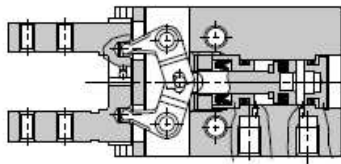

Components

No.	Description	Material	Remarks
1	Body	Aluminum alloy	Hard anodizing
2	Piston	Stainless steel	
3	Lever	Stainless steel	Heat treatment
4	Guide	Stainless steel	Heat treatment
5	Finger	Stainless steel	Heat treatment
6	Roller stopper	Stainless steel	
7	Lever shaft	Stainless steel	Nitriding
8	Holder	Brass	Electroless nicked plated
9	Holder lock	Stainless steel	
10	Cap	Aluminum alloy	Clear anodized
11	Bumper	Urethane rubber	
12	Steel ball	High carbon chromium bearing steel	Heat treatment
13	Needle roller	High carbon chromium bearing steel	Heat treatment

Components

No.	Description	Material	Remarks
14	Type C retaining ring	Carbon steel	Phosphate coated
15	Exhaust plug	Brass	Electroless nickel plating
16	Exhaust filter	Polyvinyl formal	
17	N.O. spring	Stainless steel wire for spring	
18	N.C. spring	Stainless steel wire for spring	
19	N.C. holder	Brass	Electroless nickel plating
20	N.C. spacer	Stainless steel	
21	Rod seal	NBR	
22	Piston seal	NBR	
23	Gasket	NBR	
24	Gasket	NBR	

Replacement parts

Description	MHZA2-6□	Main parts	
Seal kit	Please contact SMC to replace the seal kit, finger assembly and Piston assembly.		
Finger assembly			
Piston assembly			
Endboss assembly	MHZA2-6□□H	MHZA-A0607	Main body of adaptor Mounting screw for adaptor Seal
	MHZA2-6□□K	MHZA-A0608	
	MHZA2-6□□M	MHZA-A0609	
	MHZA2-6□□E	MHZA-A0610	

* The end boss assembly other than type E should be mounted on the special body.

Replacement part/Grease pack part no.: GR-S-010 (10 g)

3-6. Construction / Parts list, seal list MHZAJ2-6□

Double acting / Finger open

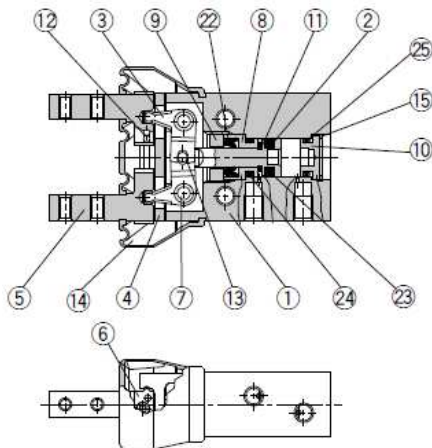

Single acting / Normal open

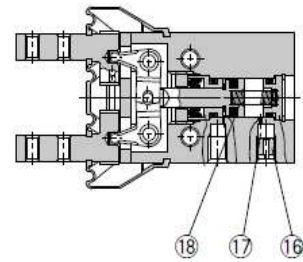

Single acting / Normal closed

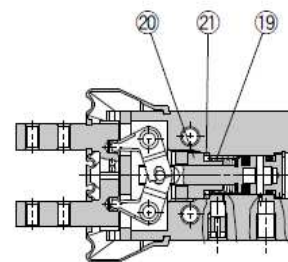

Double acting / Finger closed

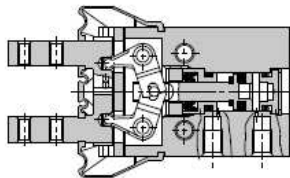

Components

No.	Description	Material	Remarks
1	Body	Aluminum alloy	Hard anodizing
2	Piston	Stainless steel	
3	Lever	Stainless steel	Heat treatment
4	Guide	Stainless steel	Heat treatment
5	Finger	Stainless steel	Heat treatment
6	Roller stopper	Stainless steel	
7	Lever shaft	Stainless steel	Nitriding
8	Holder	Brass	Electroless nicked plated
9	Holder lock	Stainless steel	
10	Cap	Aluminum alloy	Clear anodized
11	Bumper	Urethane rubber	
12	Steel ball	High carbon chromium bearing steel	Heat treatment
13	Needle roller	High carbon chromium bearing steel	Heat treatment

Components

No.	Description	Material	Remarks
14	Dust cover	CR	Chloroprene rubber
		FKM	Fluororubber
		Si	Silicone rubber
15	Type C retaining ring	Carbon steel	Nickel plating
16	Exhaust plug	Brass	Electroless nickel plating
17	Exhaust filter	Polyvinyl formal	
18	N.O. spring	Stainless steel wire for spring	
19	N.C. spring	Stainless steel wire for spring	
20	N.C. holder	Brass	Electroless nickel plating
21	N.C. spacer	Stainless steel	
22	Rod seal	NBR	
23	Piston seal	NBR	
24	Gasket	NBR	
25	Gasket	NBR	

Replacement parts

Description		MHZAJ2-6□	Main parts
Seal kit		Please contact SMC to replace the seal kit, finger assembly and Piston assembly.	
Finger assembly			
Piston assembly			
Dust cover	Material	CR	MHZAJ2-J6
		FKM	MHZAJ2-J6F
		Si	MHZAJ2-J6S
Endboss assembly	MHZAJ2-6□□H	MHZA-A0607	Main body of adaptor Mounting screw for adaptor Seal
	MHZAJ2-6□□K	MHZA-A0608	
	MHZAJ2-6□□M	MHZA-A0609	
	MHZAJ2-6□□E	MHZA-A0610	

* End boss type

Replacement part/Grease pack part no.: GR-S-010 (10 g)

H = With hose nipple, K = With One-touch fitting, M = With M3 port, E = Side ported

* The end boss assembly other than type E should be mounted on the special body.

Revision history

SMC Corporation

4-14-1, Sotokanda, Chiyoda-ku, Tokyo 101-0021 JAPAN

Tel: + 81 3 5207 8249 Fax: +81 3 5298 5362

URL <https://www.smcworld.com>