



Operation Manual

PRODUCT NAME

Magnet Gripper Unit for Collaborative Robots

MODEL / Series / Product Number

MHM-25D-X7400A

SMC Corporation

Contents

Safety Instructions	2 -
1.List of included items	4 -
2.Parts description of the magnet gripper	5 -
3.Product Specifications	6 -
3-1. How to order	6 -
3-2. Specifications	7 -
3-3. Gripping force	8 -
3-4. Dimensions	10 -
3-5. Connector and pin layout	11 -
3-6. Center of gravity	11 -
4.Product Specifications	13 -
4-1. Magnet gripper	13 -
4-2. 3-port solenoid valve	14 -
4-3. Auto switch	15 -
5.Operating method or operation	16 -
5-1. Precautions for Design	16 -
5-2. Installation	17 -
5-3. U R C a p	20 -
5-4. Air supply	26 -
5-5. Piping	26 -
5-6. Operating environment	27 -
5-7. Lubrication	27 -
6. Maintenance or inspection	27 -
6-1. Maintenance or inspection	27 -
6-2. Replacement part	28 -
6-3. Maintenance	28 -



Safety Instructions

These safety instructions are intended to prevent hazardous situations and/or equipment damage. These instructions indicate the level of potential hazard with the labels of "Caution," "Warning" or "Danger." They are all important notes for safety and must be followed in addition to International Standards (ISO/IEC)*1), and other safety regulations.

*1) ISO 4414: Pneumatic fluid power -- General rules relating to systems.

ISO 4413: Hydraulic fluid power -- General rules relating to systems.

IEC 60204-1: Safety of machinery -- Electrical equipment of machines.(Part 1: General requirements)

ISO 10218: Manipulating industrial robots -Safety.

etc.



Caution

Caution indicates a hazard with a low level of risk which, if not avoided, could result in minor or moderate injury.



Warning

Warning indicates a hazard with a medium level of risk which, if not avoided, could result in death or serious injury.



Danger

Danger indicates a hazard with a high level of risk which, if not avoided, will result in death or serious injury.



Warning

1. The compatibility of the product is the responsibility of the person who designs the equipment or decides its specifications.

Since the product specified here is used under various operating conditions, its compatibility with specific equipment must be decided by the person who designs the equipment or decides its specifications based on necessary analysis and test results.

The expected performance and safety assurance of the equipment will be the responsibility of the person who has determined its compatibility with the product.

This person should also continuously review all specifications of the product referring to its latest catalog information, with a view to giving due consideration to any possibility of equipment failure when configuring the equipment.

2. Only personnel with appropriate training should operate machinery and equipment.

The product specified here may become unsafe if handled incorrectly.

The assembly, operation and maintenance of machines or equipment including our products must be performed by an operator who is appropriately trained and experienced.

3. Do not service or attempt to remove product and machinery/equipment until safety is confirmed.

1. The inspection and maintenance of machinery/equipment should only be performed after measures to prevent falling or runaway of the driven objects have been confirmed.

2. When the product is to be removed, confirm that the safety measures as mentioned above are implemented and the power from any appropriate source is cut, and read and understand the specific product precautions of all relevant products carefully.

3. Before machinery/equipment is restarted, take measures to prevent unexpected operation and malfunction.

4. Contact SMC beforehand and take special consideration of safety measures if the product is to be used in any of the following conditions.

1. Conditions and environments outside of the given specifications, or use outdoors or in a place exposed to direct sunlight.

2. Installation on equipment in conjunction with atomic energy, railways, air navigation, space, shipping, vehicles, military, medical treatment, combustion and recreation, or equipment in contact with food and beverages, emergency stop circuits, clutch and brake circuits in press applications, safety equipment or other applications unsuitable for the standard specifications described in the product catalog.

3. An application which could have negative effects on people, property, or animals requiring special safety analysis.

4. Use in an interlock circuit, which requires the provision of double interlock for possible failure by using a mechanical protective function, and periodical checks to confirm proper operation.



Safety Instructions

Caution

The product is provided for use in manufacturing industries.

The product herein described is basically provided for peaceful use in manufacturing industries. If considering using the product in other industries, consult SMC beforehand and exchange specifications or a contract if necessary.

If anything is unclear, contact your nearest sales branch.

Limited warranty and Disclaimer/Compliance Requirements

The product used is subject to the following “Limited warranty and Disclaimer” and “Compliance Requirements”.

Read and accept them before using the product.

Limited warranty and Disclaimer

1. The warranty period of the product is 1 year in service or 1.5 years after the product is delivered, whichever is first. □2)

Also, the product may have specified durability, running distance or replacement parts. Please consult your nearest sales branch.

2. For any failure or damage reported within the warranty period which is clearly our responsibility, a replacement product or necessary parts will be provided.

This limited warranty applies only to our product independently, and not to any other damage incurred due to the failure of the product.

3. Prior to using SMC products, please read and understand the warranty terms and disclaimers noted in the specified catalog for the particular products.

□□2) Vacuum pads are excluded from this 1 year warranty.

A vacuum pad is a consumable part, so it is warranted for a year after it is delivered.

Also, even within the warranty period, the wear of a product due to the use of the vacuum pad or failure due to the deterioration of rubber material are not covered by the limited warranty.

Compliance Requirements

1. The use of SMC products with production equipment for the manufacture of weapons of mass destruction(WMD) or any other weapon is strictly prohibited.

2. The export of SMC products or technology from one country to another is governed by the relevant security laws and regulations of the countries involved in the transaction. Prior to the shipment of an SMC product to another country, ensure that all local rules governing that export are known and followed.

Caution

SMC products are not intended for use as instruments for legal metrology.

Measurement instruments that SMC manufactures or sells have not been qualified by type approval tests relevant to the metrology (measurement) laws of each country.

Therefore, SMC products cannot be used for business or certification ordained by the metrology (measurement) laws of each country.

1.List of included items

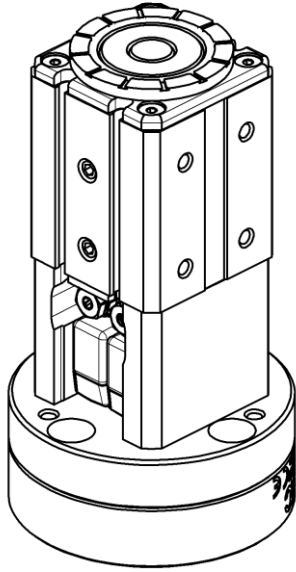

Magnet gripper unit 1pc.

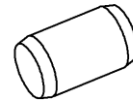

Positioning pin (6×10) 1pc.
For positioning the product.

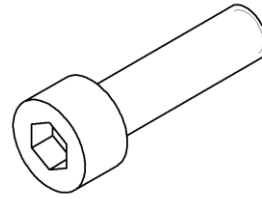

Hexagon socket head cap screw
(M6×23) 4pcs.
For mounting the product.

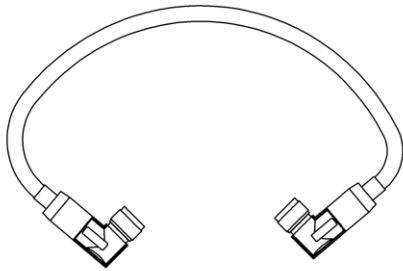

M8 8 Pin connector 1pc.

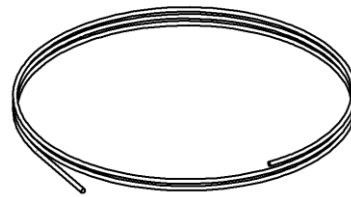

Polyurethane tube for piping $\phi 4$
(TU0425) 2m

2.Parts description of the magnet gripper

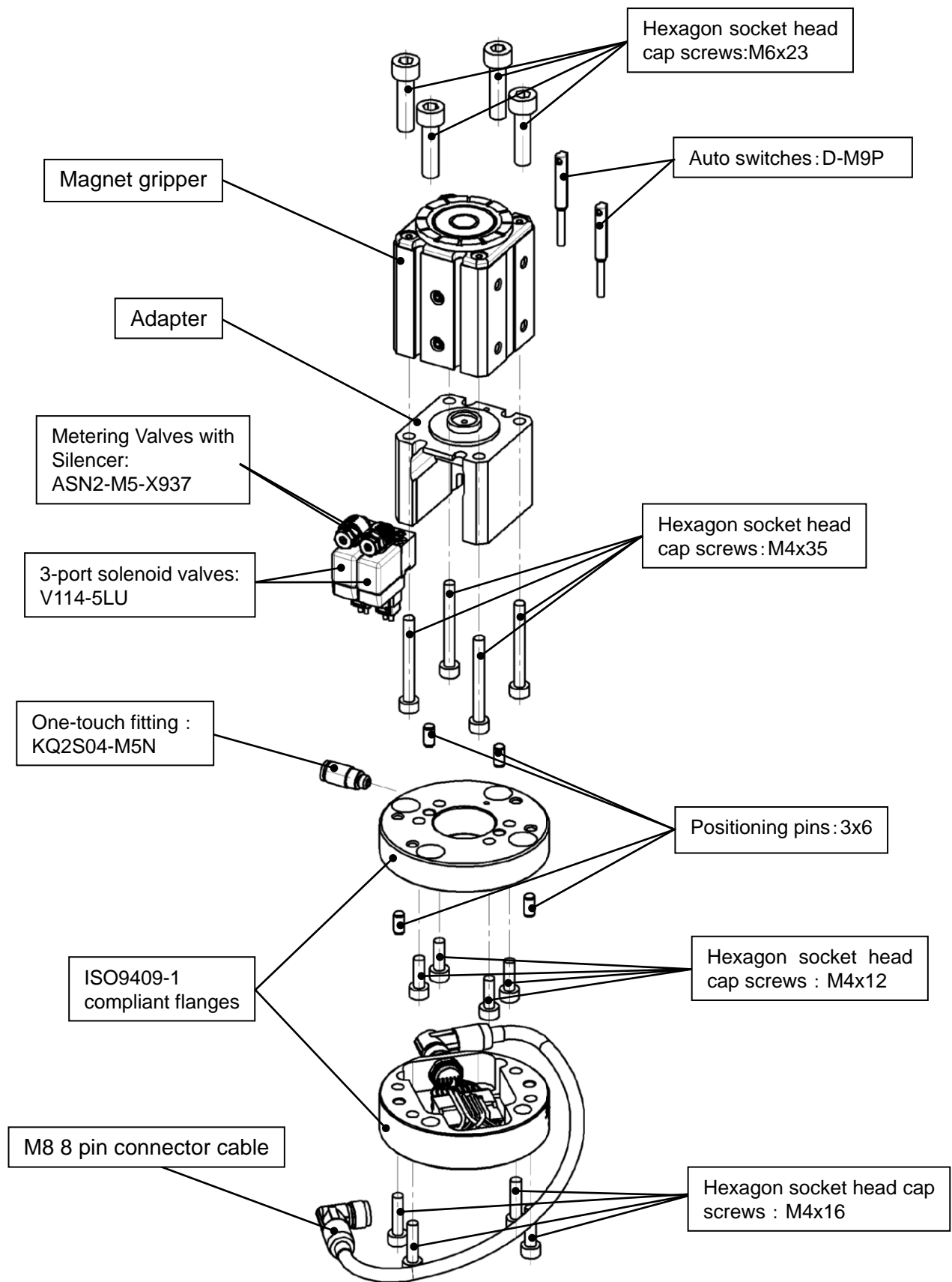

3.Product Specifications

3-1. How to order

MHM - 25 D - X7400A

● Bore size

φ 25

3-2. Specifications

Specifications

Fluid		Air
Operating method		Double acting
Operating pressure		0.2 to 0.6MPa
Proof pressure		0.9MPa
Ambient and operating fluid temperature(°C)		-10 to 50
Gripping Force *	Workpiece thickness:2mm	160N
	Workpiece thickness:6mm	200N
Residual holding force		0.3 N or less
Lubrication		Non-lube
Weight (g)		590g
Auto switch model		D-M9P
Standard for mounting onto the robot		ISO9409-1-50-4-M6
Connector configuration of the accessory		Both side M8 8 pin connector(Socket)

*1 Theoretical holding force (reference value) when a low carbon steel plate is held by entire surface attraction surface

In the default setting, the auto switch is fixed at the workpiece release position.

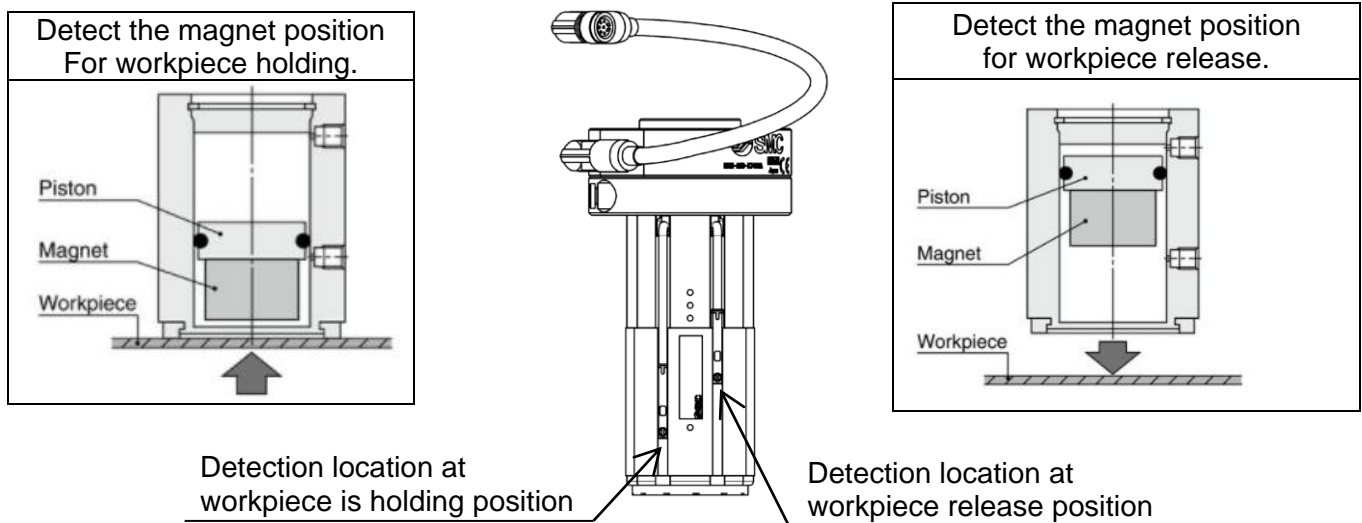

* For examples of setting auto switch and setting of mounting position of auto switches, please refer to the MHM Series catalogue P.12 onwards on our website (www.smcworld.com).

* Auto switches are used for checking the operation of the magnet gripper. They do not guarantee the actual holding and release of the workpiece. For checking the holding / release of the workpiece, a proximity sensor should be mounted separately.

3-3. Gripping force

Holding conditions.

- To lift workpieces vertically, be sure to take into consideration the acceleration rate, air pressure, impact etc., in addition to the mass of the workpieces.

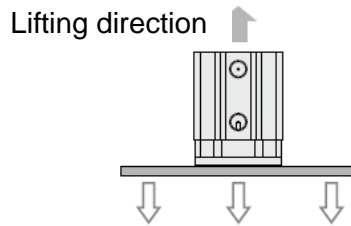

- Consider the center of gravity of the workpiece to avoid moments being applied the magnet gripper as much as possible.

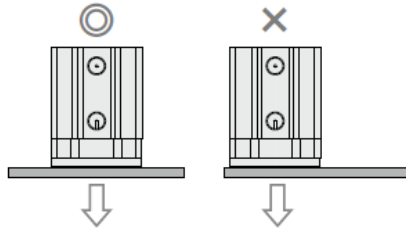

- If multiple magnet grippers are used for transferring a workpiece with a large surface area, properly allocate the magnet grippers to maintain balance.

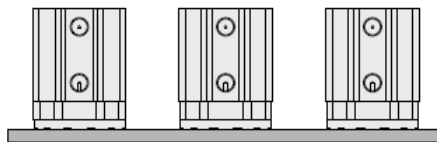

- Horizontal movement of the magnet gripper may cause sideslip of the workpiece depending on the acceleration or friction coefficient between the pad and workpiece. Therefore, the acceleration rate of the lateral movement must be minimized.

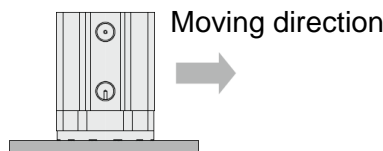

- Use the magnet gripper for horizontal handling. Adequate safety factor needs to be considered for inclined handling or vertical handling.

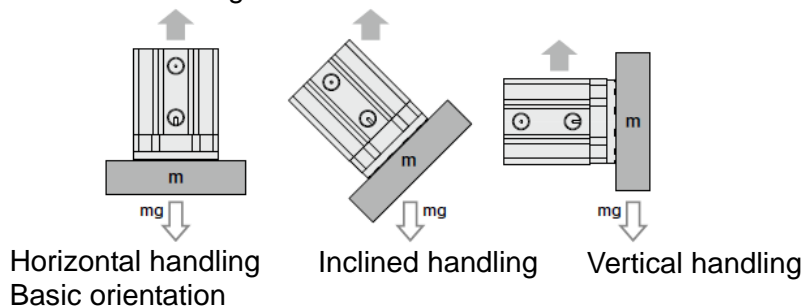

- Thin workpieces may be deformed during transportation. It is recommended to use multiple magnet grippers for scenarios such as this.

Calculate the required holding force.

$$W = S \frac{mg}{n}$$

W: Required holding force

n : Number of magnet grippers [pcs.]

m: Workpiece mass [kg]

g : Gravitational acceleration [= 9.8 m/s²]

S : Safety factor Horizontal lifting: 4 or more



The holding force graph shows the theoretical value for low carbon steel plate. Holding forces very depending on the material and shape of the workpiece. Please perform a holding test referring to the value selected based on the graph.

3-4. Dimensions

Refer to P13, P14 and P15 for the dimensions of the magnet gripper, valves and auto switches.

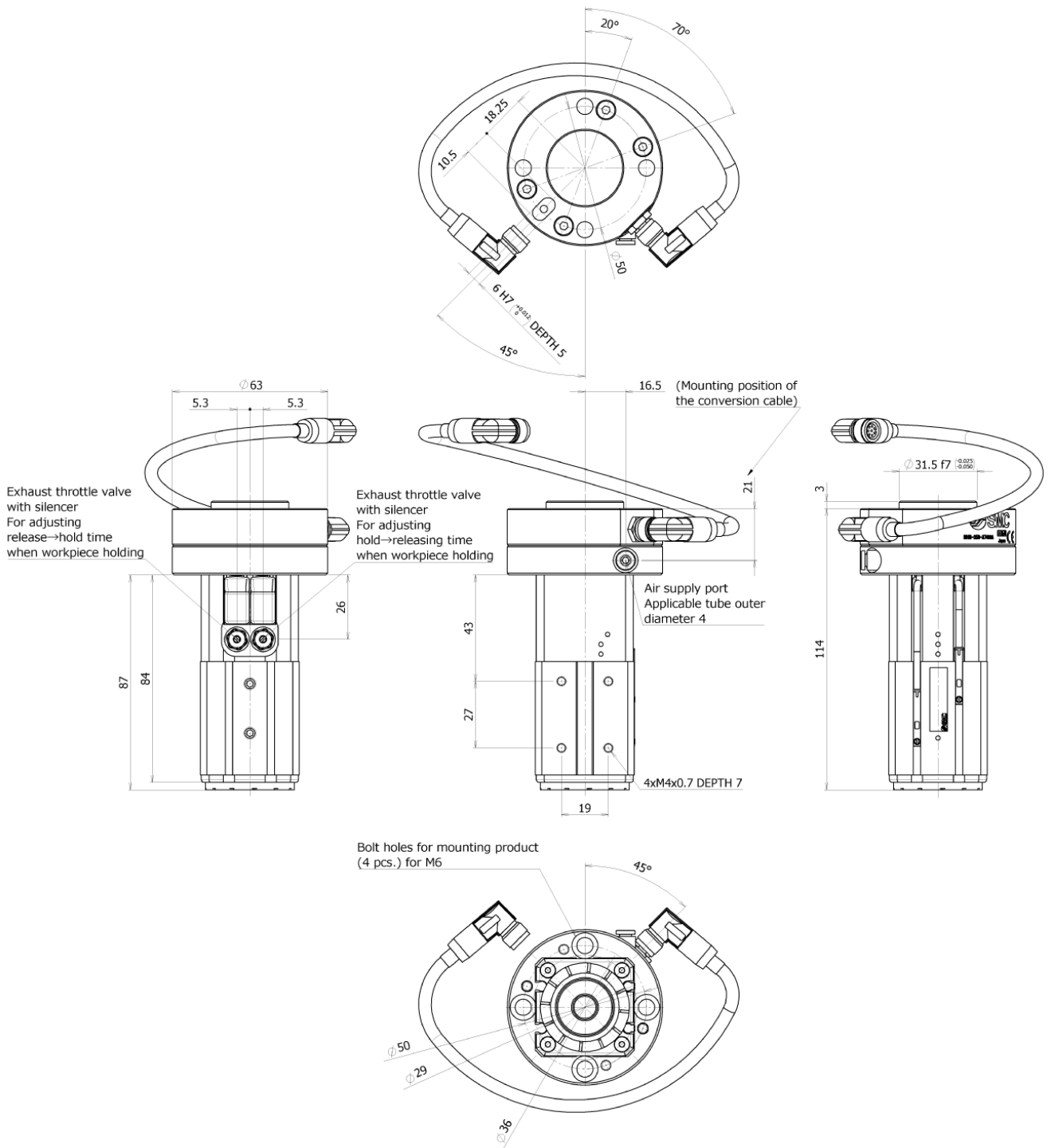

3-5. Connector and pin layout

Attached cable is fixed to the product.

Connect the communication cable correctly. Refer to P.18 for assembling method.

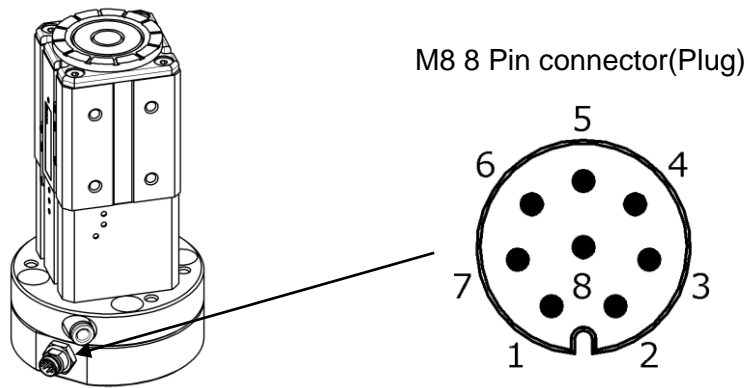

PNP output

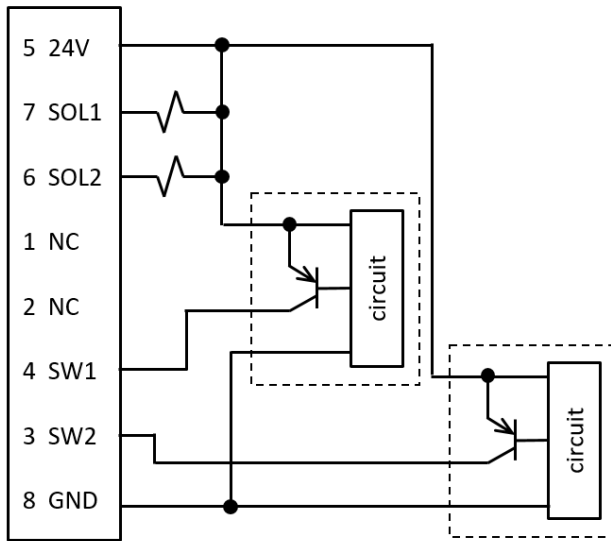

PIN No.	Function	Explanation
1	-	NC
2	-	NC
3	Auto switch (For holding position)	-
4	Auto switch (For releasing position)	-
5	+24V	Power supply for 24 VDC
6	Valve ON/OFF (For holding position)	-
7	Valve ON/OFF (For releasing position)	-
8	GND	Power supply for 0 VDC

Conversion cable

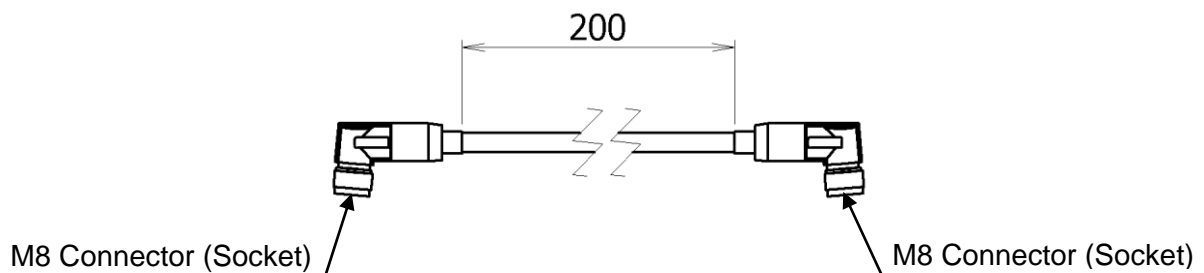

3-6. Center of gravity

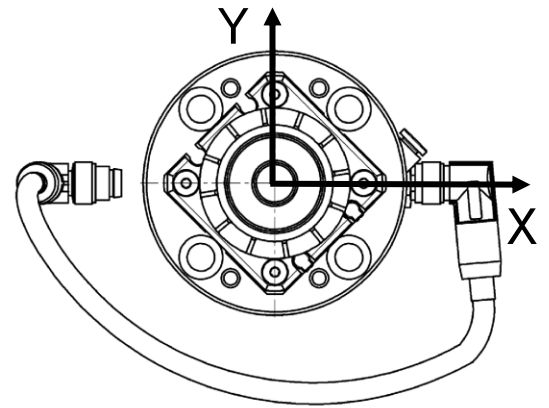
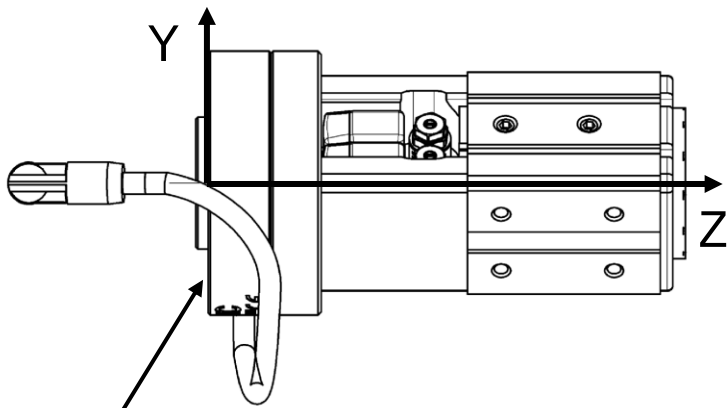

Flange
mounting surface

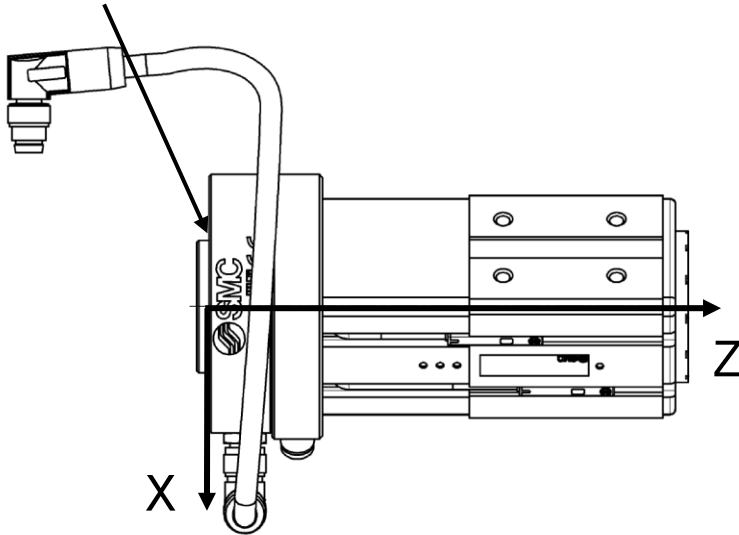

Center of gravity		
X	Y	Z
-0.1	-0.5	55.8

4.Product Specifications

* For detailed specifications not included in this document, please refer to the our website (www.smcworld.com) or operation manual.

4-1. Magnet gripper

Specifications

Fluid		Air
Operating pressure [MPa]		0.2 to 0.6
Operating method		Double acting
Proof pressure		0.9MPa
Ambient and operating fluid temperature(°C)		-10 to 60
Gripping force *	Workpiece thickness:2mm	160N
	Workpiece thickness:6mm	200N
Residual holding force		0.3 N or less
Lubrication		Non-lube
Weight (g)		244

*1 Theoretical holding force (reference value) when a low carbon steel plate is held by entire surface attraction surface

Dimensions.

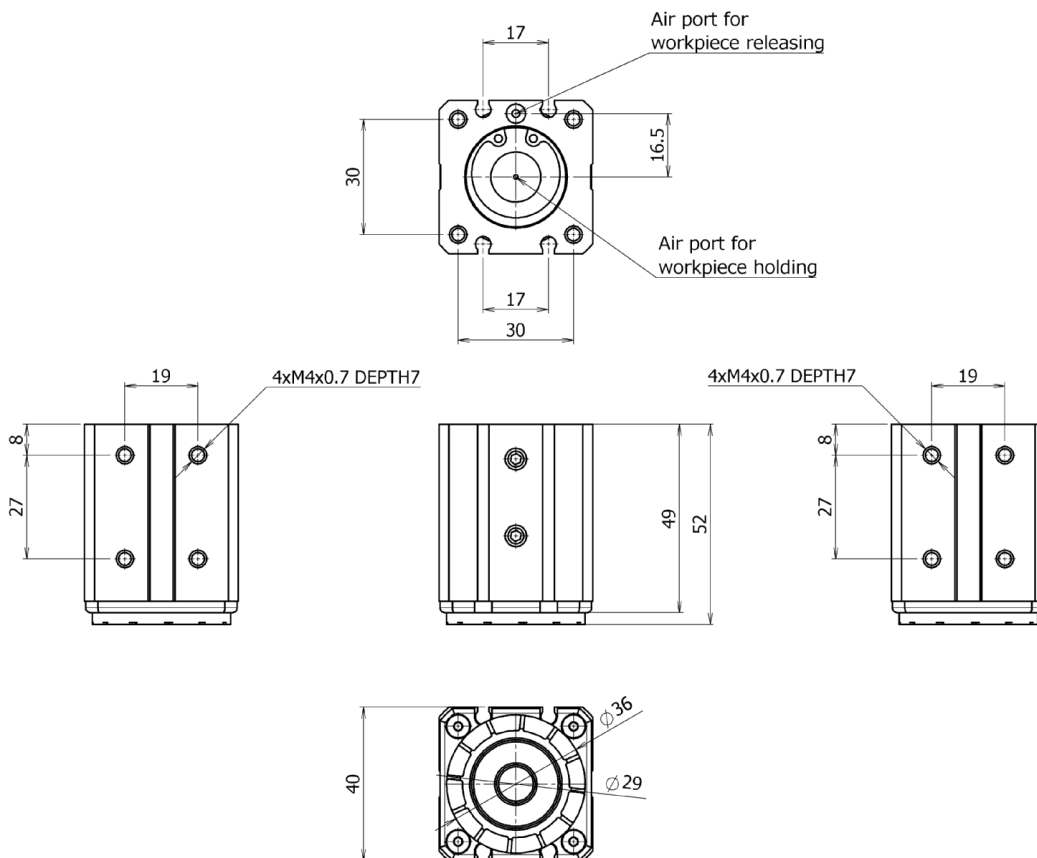

Caution

This special magnet gripper cannot be replaced with MHM-25D because the piping direction is different.

4-2. 3-port solenoid valve

Specifications

Model No.	V114-5LU
Fluid	Air
Ambient and operating fluid temperature(°C)	-10 to 50 (No freezing)
Response time [ms]	ON : 5 or less OFF : 4 or less
Minimum operation frequency [Hz]	20
Lubrication	Non-lube
Mounting orientation	Free
Impact resistance/Vibration resistance (m/s ²)	150/30
Enclosure rating	Dustproof

Solenoid specifications

Model No.	V114-5LU
Electrical entry	L shaped plug connector (L)
Coil rated voltage [V]	24
Allowable voltage fluctuation	-10 to 10%
Power consumption [W]	0.4 [Starting 0.4,Holding 0.1]
Surge voltage suppressor	Please refer to page 1367 of the Best Pneumatics catalogue.
Indicator LED	LED

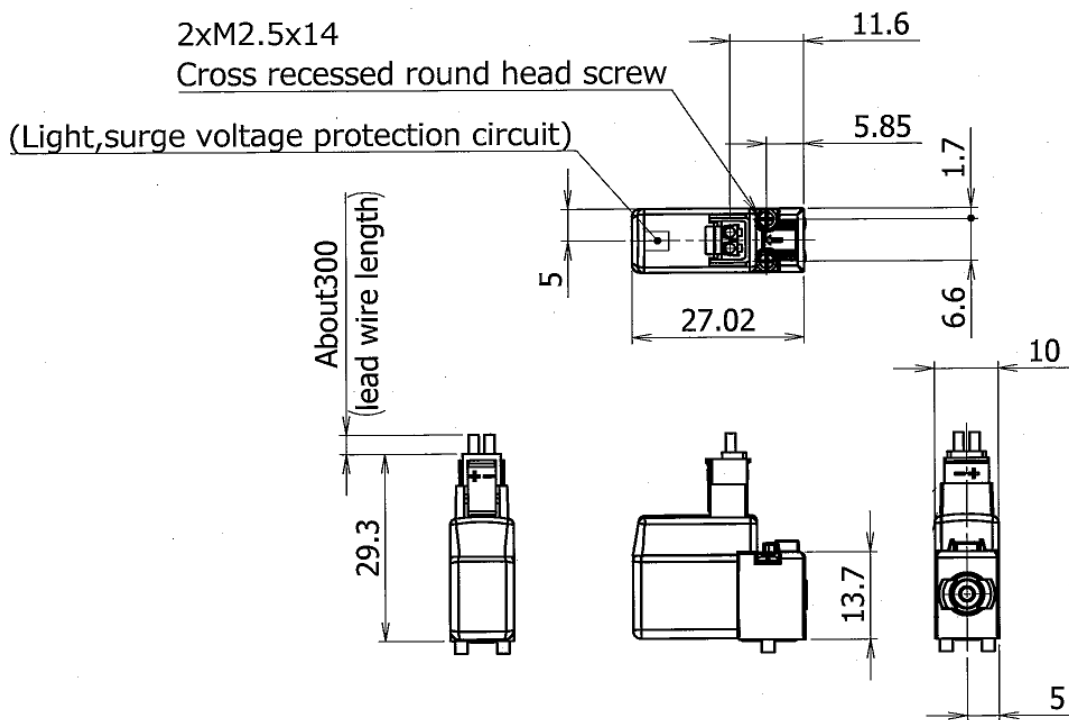

4-3. Auto switch

Auto Switch Specifications

D-M9P(With indicator light)	
Auto switch model	D-M9P
Electrical entry direction	In-line
Wiring	3-wire
Output	PNP type
Applicable load	IC circuit, Relay, PLC
Power supply voltage	DC5 · 12 · 24V(4.5 to 28V)
Current consumption	10 mA or less
Load voltage	-
Load current	40 mA or less
Internal voltage drop	0.8 V or less at 10 mA (2 V or less at 40 mA)
Current leakage	100 μ A or less at 24 VDC
Indicator LED	Red LED illuminates when turned ON.
Standard	CE marking、RoHS

Dimensions

D-M9P

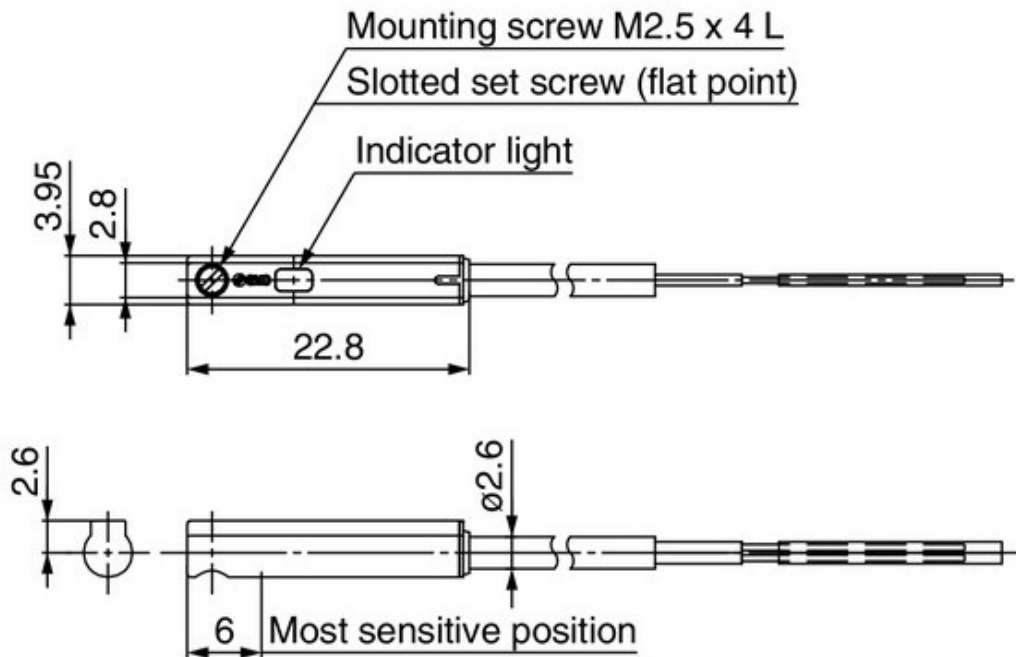

5. Operating method or operation

5-1. Precautions for Design

Warning

1. Confirm the specifications.

Products represented in this catalog are designed only for use in compressed air systems (including vacuum). Do not operate at pressures, temperatures, etc., beyond the range of specifications, as this can cause damage or malfunction. (Refer to the specifications.) Please contact SMC when using a fluid other than compressed air (including vacuum). We do not guarantee against any damages if the product is used outside of the specification range.

2. Take safety measures (e.g. mounting protective covers) when there is a danger of fingers being caught between the magnet gripper and the workpiece or with moving workpieces causing personal injury.

3. Select a model whose holding force is compatible with the workpiece mass.

Expected holding force may not be obtained depending on the material or shape of the workpiece, please evaluate the safety against the fall of workpiece with actual machine.

4. Do not use in applications where excessive external force or impact force may be applied to the gripper.

5. Consider the possibility of a power source related malfunction.

Measures should be taken to prevent injury and equipment damage in the event that there is a power malfunction to equipment controlled by air pressure, electricity or hydraulics, etc.

6. Consider the action of the product in the event of an emergency stop.

Devise a safe system so that if a person engages the emergency stop or if a safety device is tripped during a system malfunction, such as a power outage, the operation of the magnet gripper will not cause a hazard to humans or damage the equipment.

7. Consider the action when operation is restarted after an emergency or abnormal stop.

Design machinery so that bodily injury or equipment damage will not occur upon the restart of operation.

8. Do not disassemble the product or make any modifications, including additional machining.

Doing so may cause human injury and/or an accident.

9. Refer to the Auto Switches Precautions (Web Catalog) if using with an auto switch.

10. Risk to people with pacemakers

The product has a magnet inside. It may interfere with the use of an electronic equipment such as a pacemaker. People with pacemakers should stay away from the magnet gripper or take safety measures to block the magnetic force.

Caution

1. If pressure is applied to the external magnet gripper parts, there is a possibility that air will get inside the cylinder from the rod seal section. (Example : inside a chamber, etc.)

2. Keep away from objects which are influenced by magnets.

As the body magnets are built-in, do not allow close contact with magnetic disks, magnetic cards, or magnetic tapes. Data may be erased.

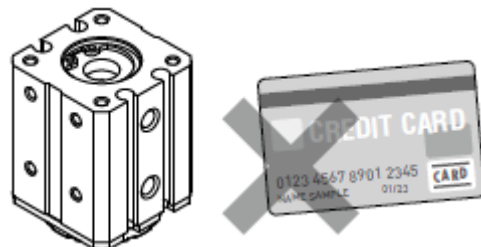

5-2. Installation

Warning

- 1. Keep the manual in a safe place for future reference. The product should be mounted and operated only after thoroughly reading the operation manual and understanding its contents.**
- 2. Ensure sufficient space for maintenance activities.**

When installing the products, allow access for maintenance and inspection.

- 3. Observe the tightening torque for screws.**

Tighten the screws to the recommended torque for mounting the product.

- 4. Do not place a magnetic object near the product.**

The auto switch is a magnetic sensing type product. If a magnetic object is placed close to it, the product could operate suddenly, which could pose a hazard to humans or damage the machinery and equipment. When the magnet grippers are used in parallel, keep the specified cap between them to avoid malfunction.

- 5. Do not perform additional machining to the product.**

Additional machining to the product can result in insufficient strength and cause damage to the product. This can lead to possible human injury or damage to the surrounding equipment.

- 6. Do not enlarge the fixed orifice by modifying the pipe connectors.**

If the fixed orifice is enlarged, the speed of switching between holding and releasing increases which results in higher impact forces. This may lead to damage to the product, which can lead to human injury and damage to other equipment and machinery.

- 7. When the magnet moves toward the magnetic attraction surface, holding force is generated on the attraction surface, Make sure that holding force is not generated when working around the magnet gripper so that your fingers do not get caught in the magnet gripper.**

Caution

- 1. Do not scratch or dent the magnet gripper by dropping or bumping it when mounting.**

Even a slight deformation can cause malfunction.

- 2. Be careful with the magnetic attraction of parts of objects around the magnet gripper when mounting the magnet gripper while it is in its holding position (the piston is on the attraction side). They may cause injury.**

- 3. When mounting the product, tighten it with screws of appropriate length at an appropriate torque.**

Tightening with a torque greater than the specified torque can cause malfunction, while insufficient tightening can cause slippage and dropping.

- 4. Do not apply impact load to the center of the magnetic attraction surface.**

Otherwise, it may result in a breakage or malfunction.

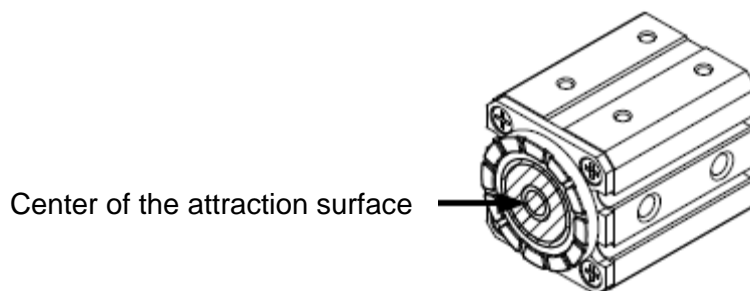

How to Mount Magnet Gripper

Adjust the robot arm position before mounting so that the mounting is easy.

(1) Mounting to the robot arm

Hexagon socket head
cap screw (M6 x 23)

Max. tightening torque :
6.3Nm

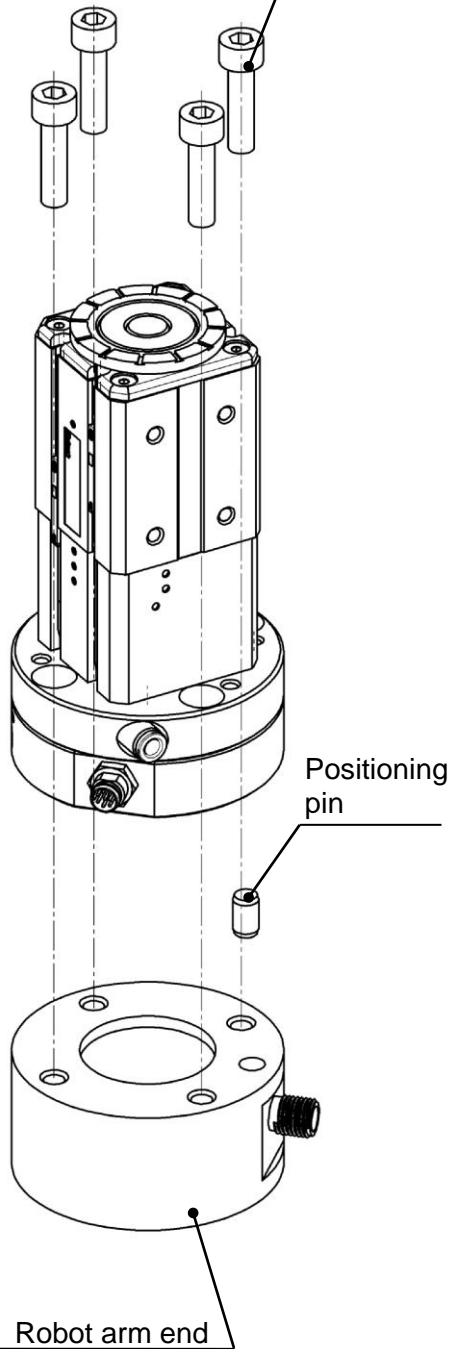

(2) Connecting the M8 connector

- * Do not energize while securing the connector.
- * Check that the connector is not loose.

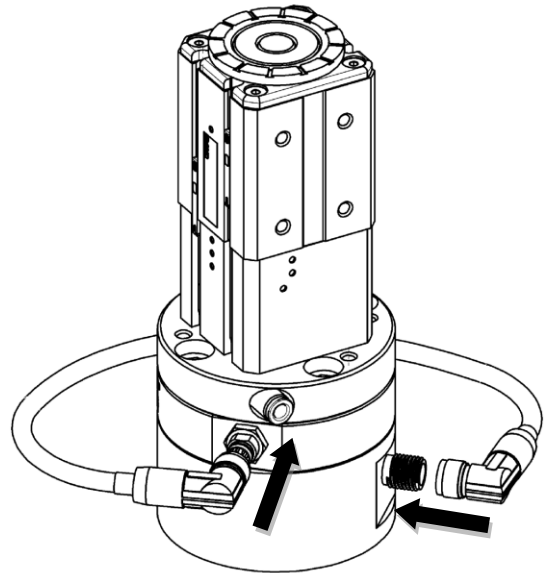

Operation time adjustment method for holding / releasing the workpiece

The piston operation time during workpiece holding / release can be adjusted by adjusting the opening of the metering speed controller valve.

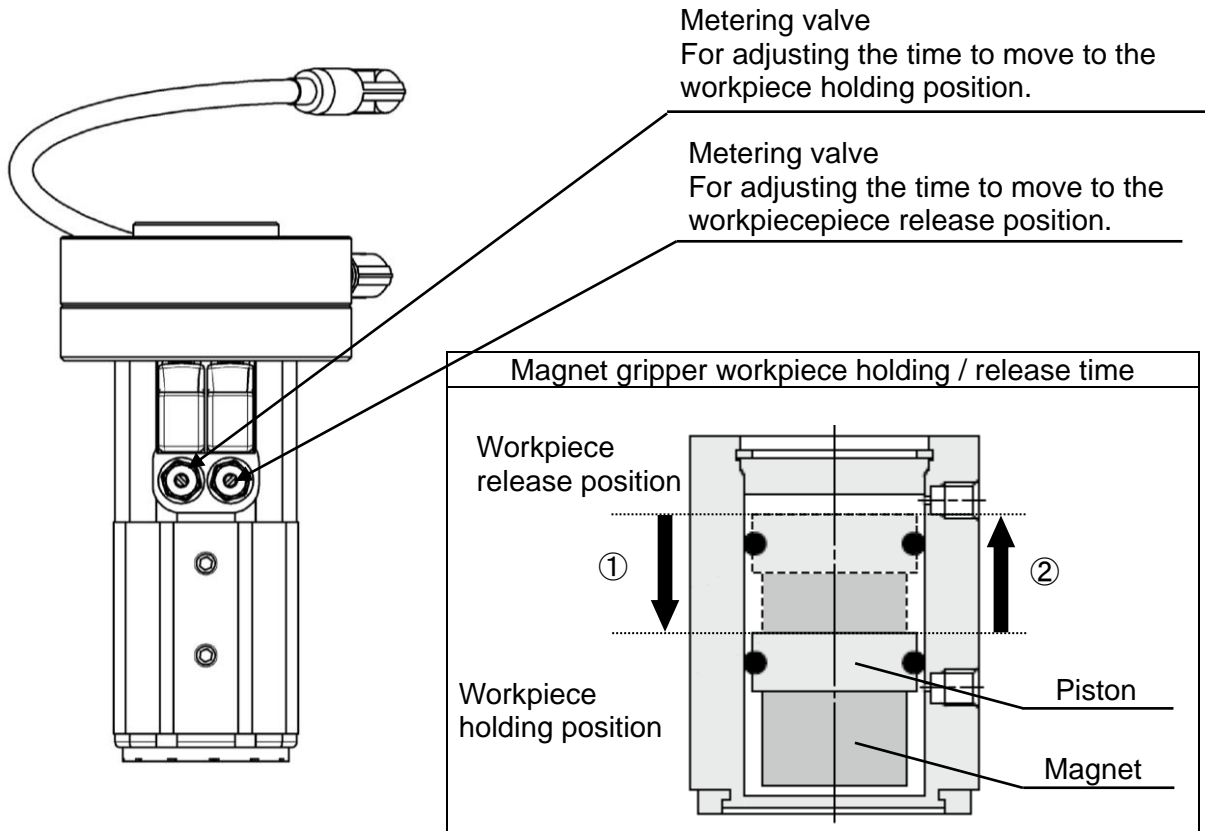

- * (1) Workpiece holding time: Time required when the piston and magnet travel from the workpiece release position to the workpiece holding position
- * (2) Workpiece release time: Time required when the piston and magnet travel from the workpiece holding position to the workpiece release position

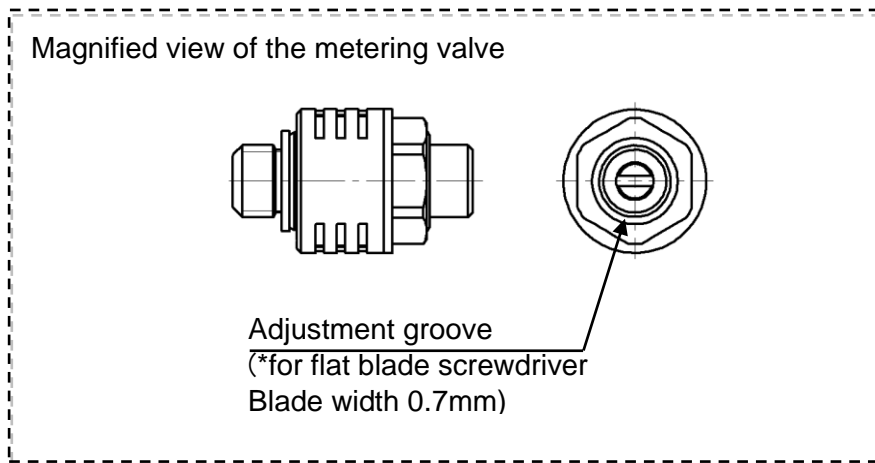

- * Use a flat blade screwdriver for adjusting the restriction of the metering valves.
- * Keep the restriction of the 2 metering valves approximately the same. If they are different too much, the operation may become unstable.

5-3. U R C a p

Installation and basic setting

1. Installation of URCap

- (1) Tap the "URCap" menu from the robot settings screen.
- (2) Insert the USB memory with a copy of the downloaded file into the teaching pad and tap the "+" button.

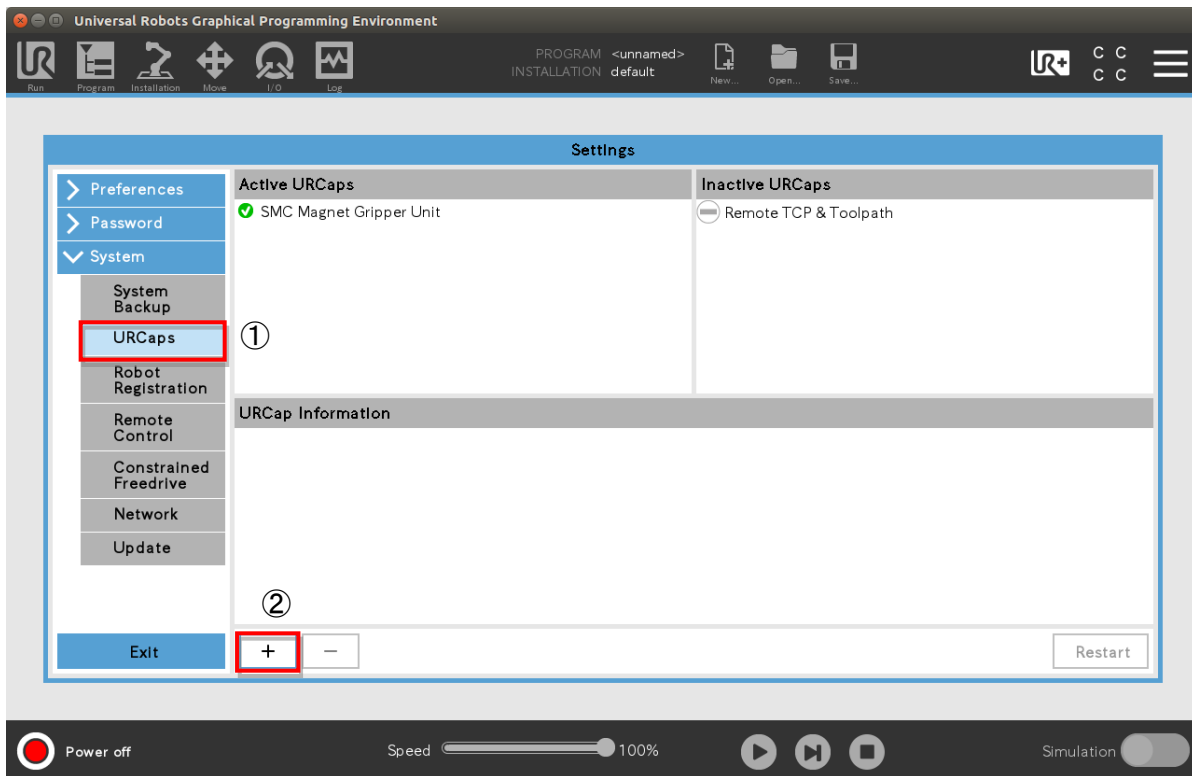

- (3) Select "SMC-Air Gripper Unit-xxx.urcap" from the file screen and tap the "open" button.
- (4) Tap the "Restart" button to restart the robot.

2. Select "SMC Magnet Gripper Unit" on the "URCaps" menu for basic settings.

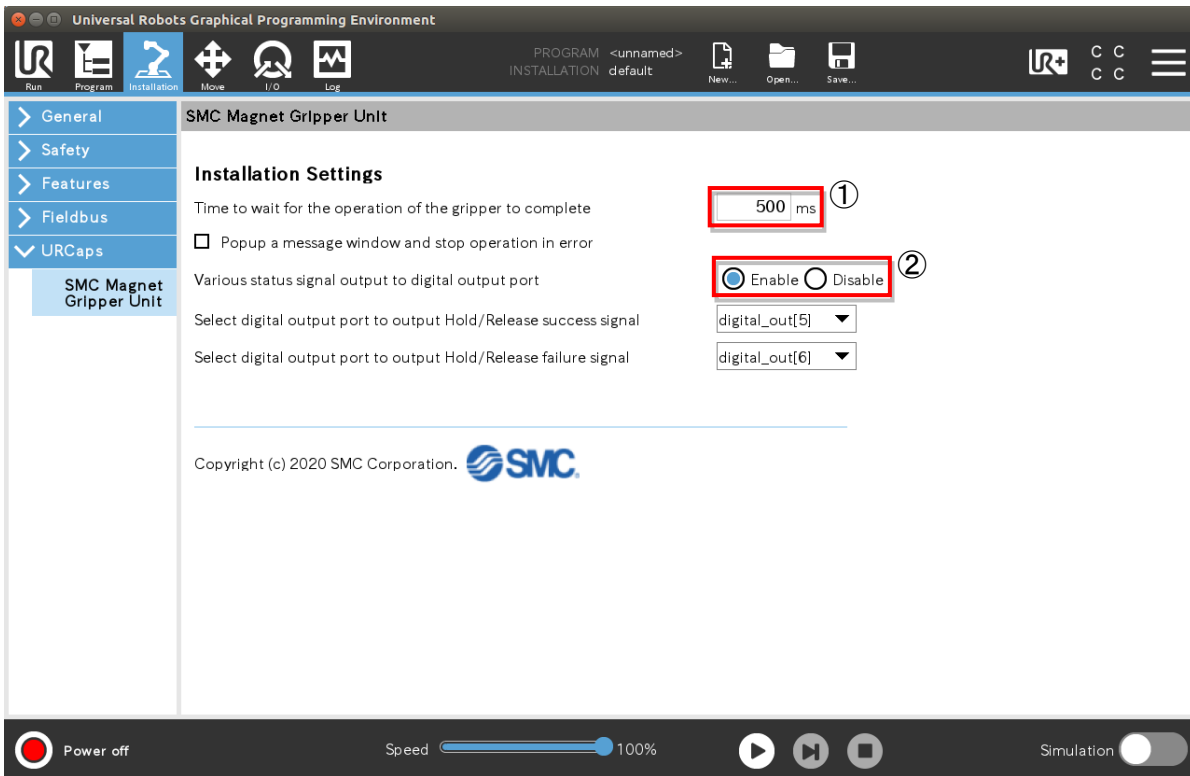

① "Time to wait for the operation of the gripper to complete"

If the NODE is "RELEASE ONLY NODE" or "HOLD ONLY NODE" (see P.21 for NODE), the delay time between outputting the valve switching signal and the transition of the robot to the next operation can be set.

If the NODE is "RELEASE AND CHECK SIGNAL NODE" or "HOLD AND CHECK SIGNAL NODE", the delay time between outputting the valve switching signal and starting of the monitoring of the auto switch input signal can be set.

Enter the appropriate value according to the opening/closing speed of the finger by adjusting the metering valve.

Example 1. **Set value 500ms.** "RELEASE ONLY NODE" or "HOLD ONLY NODE".

When the valve switching signal is output, the robot operation moves to next operation in 500ms. If the finger operation time is less than 500ms, the robot will only move to the next operation when 500ms has passed, even if the finger has completed its operation at less than 500ms from the valve switching. If the finger operation time is 500ms or more, it is necessary to be careful because the robot moves to the next operation before the finger operation is completed.

Example 2. **Set value 500ms.** "RELEASE AND CHECK SIGNAL NODE" or "HOLD AND CHECK SIGNAL NODE".

In 500ms after the valve switching signal is output, the monitoring of the auto switch input signal begins. If the finger operation time is less than 500ms, the monitoring of the auto switch signal begins when 500ms has passed, even if the finger has completed its operation at less than 500ms from the valve switching. If the finger operation time is more than 500ms, the auto switch signal monitoring begins when 500ms has passed even when the finger is in operation.

② "Popup a message window and stop operation in error"

Sets the error handling.

When "Popup message: Stopping operation when error occurs" is checked in Installation Settings and "RELEASE AND CHECK SIGNAL NODE" or "HOLD AND CHECK SIGNAL NODE" is checked in Select operation (refer to page 22), error handling can be set in case of workpiece holding and release fail.

When the box is checked :

When workpiece holding or release fails (auto switch detection does not work), the above message pops up and the program stops.

In this case, failure signal is output and it can be assigned to the Hold/Release failure signal in ③ "Various status signal output to digital output port".

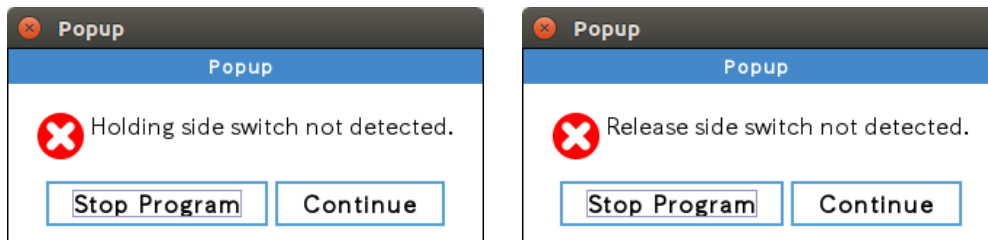

When the box is not checked :

Even though workpiece holding or release fails (auto switch detection does not work), the above message does not pop up and the program continues.

In this case, failure signal is output and it can be assigned to the Hold/Release failure signal in ③ "Various status signal output to digital output port".

* The check box is not checked in the default setting.

* The auto switches are used for checking the operation of the magnet gripper. They do not guarantee holding / release of the actual workpiece.

"Various status signal output to digital output port":

Sets the status of the output port. If "Enable" is selected, the signal for open/close success, failure, and workpiece drop detection can be assigned to the output port No.5 / 6 / 7, respectively. Select "Disable" when the output port is not used.

* The auto switches are used for checking the operation of the magnet gripper. They do not guarantee holding / release of the actual workpiece.

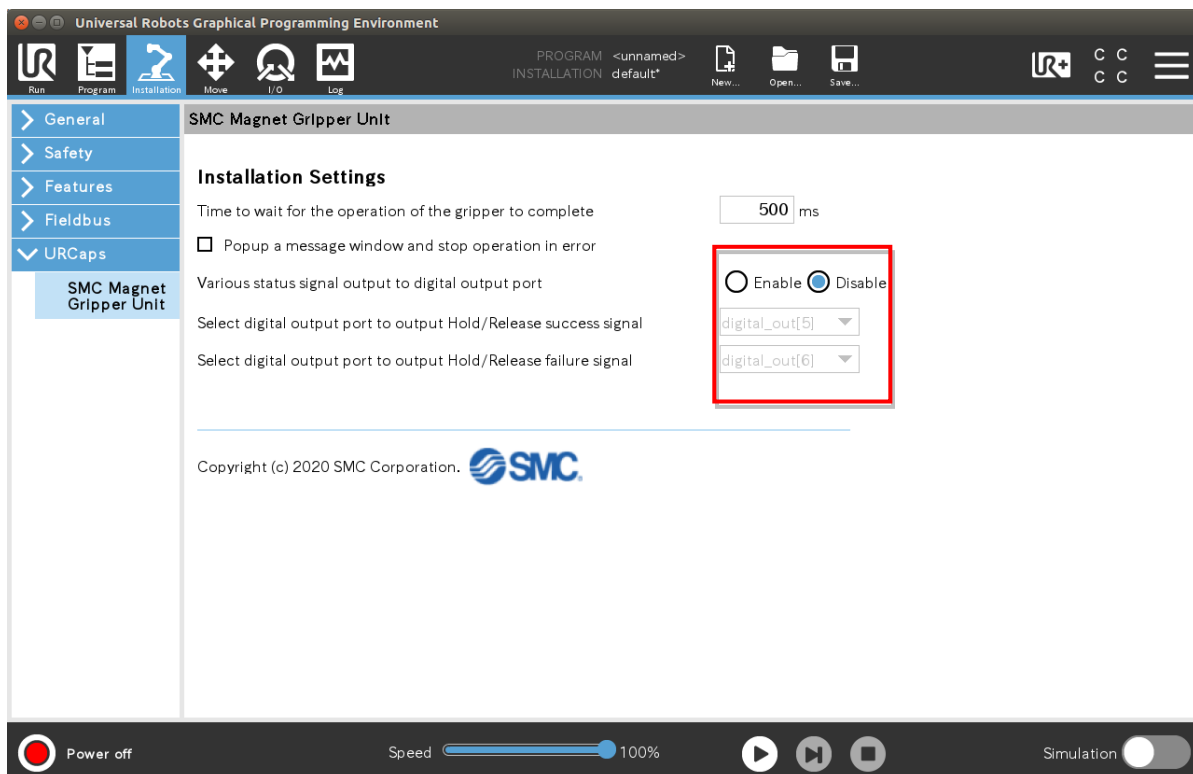

Different signal cannot be assigned to the same port.

Universal Robots Graphical Programming Environment

PROGRAM <unnamed>
INSTALLATION default*

Run Program Installation Move I/O Log

New... Open... Save...

UR+ C C C C

> General
> Safety
> Features
> Fieldbus
v URCaps

SMC Magnet Gripper Unit

Installation Settings

Time to wait for the operation of the gripper to complete ms

Popup a message window and stop operation in error

Various status signal output to digital output port Enable Disable

Select digital output port to output Hold/Release success signal

Select digital output port to output Hold/Release failure signal

WARNING : Slected signals are set on the same port.

Copyright (c) 2020 SMC Corporation. 

Power off Speed 100% Simulation

Program setting

Operation program can be set from the “Program” tab.

①:“Select operation”

4 type of operation NODEs are available.

1: “OPEN ONLY NODE” opens the finger. This does not monitor the auto switch signal.

2: Fingers are open when “OPEN AND CHECK SIGNAL NODE” is executed. In this case, after checking the auto switch signal and confirming the reaction, the transition of the operation occurs.

3: “OPEN ONLY NODE” closes the finger. This does not monitor the auto switch signal.

4: Fingers are closed when “CLOSE AND CHECK SIGNAL NODE” is executed. In this case, after checking the auto switch signal and confirming the reaction, the transition of the operation occurs.

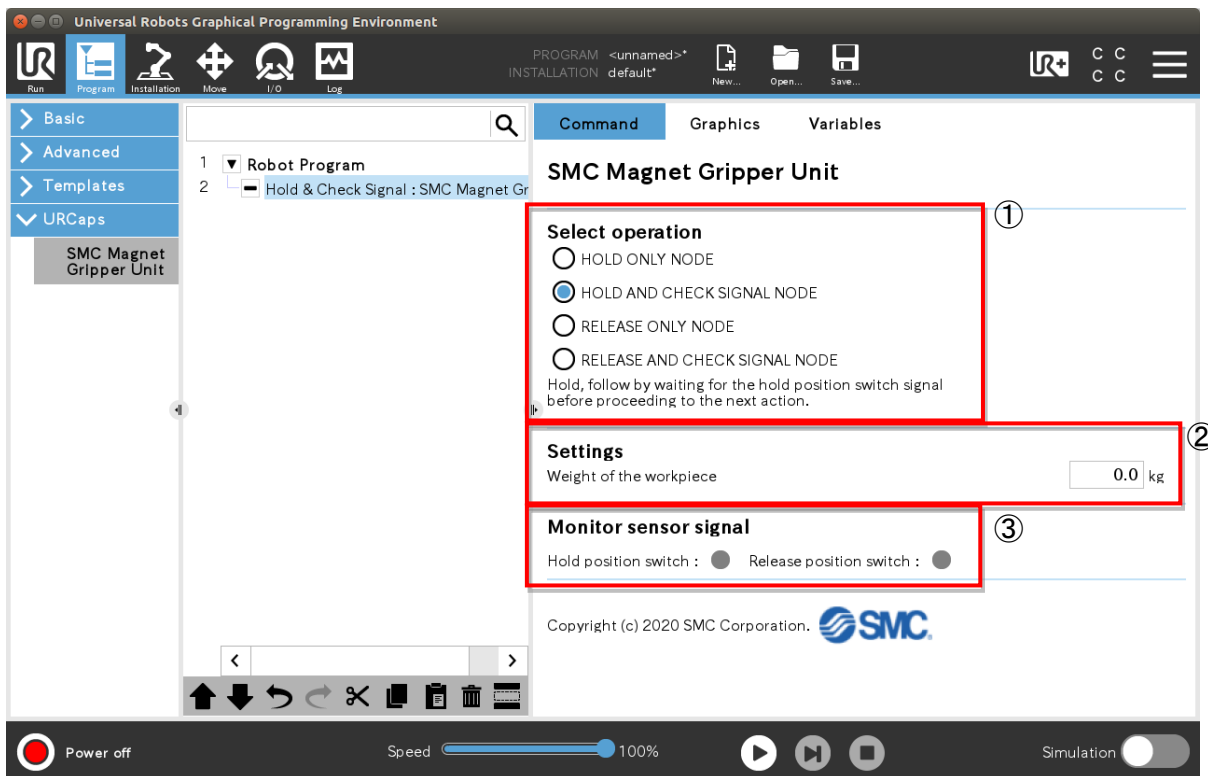

②“Settings”

Enter the mass of the transferred object.

③:“Monitor sensor signal”

Auto switch signal detection can be confirmed on the screen.

Manual operation

From the UR+ icon in the upper right corner of the screen, the manual operation of the gripper can be checked. The gripper operation (open or close) and the auto switch reaction can be checked by tapping the Open/ Close button.

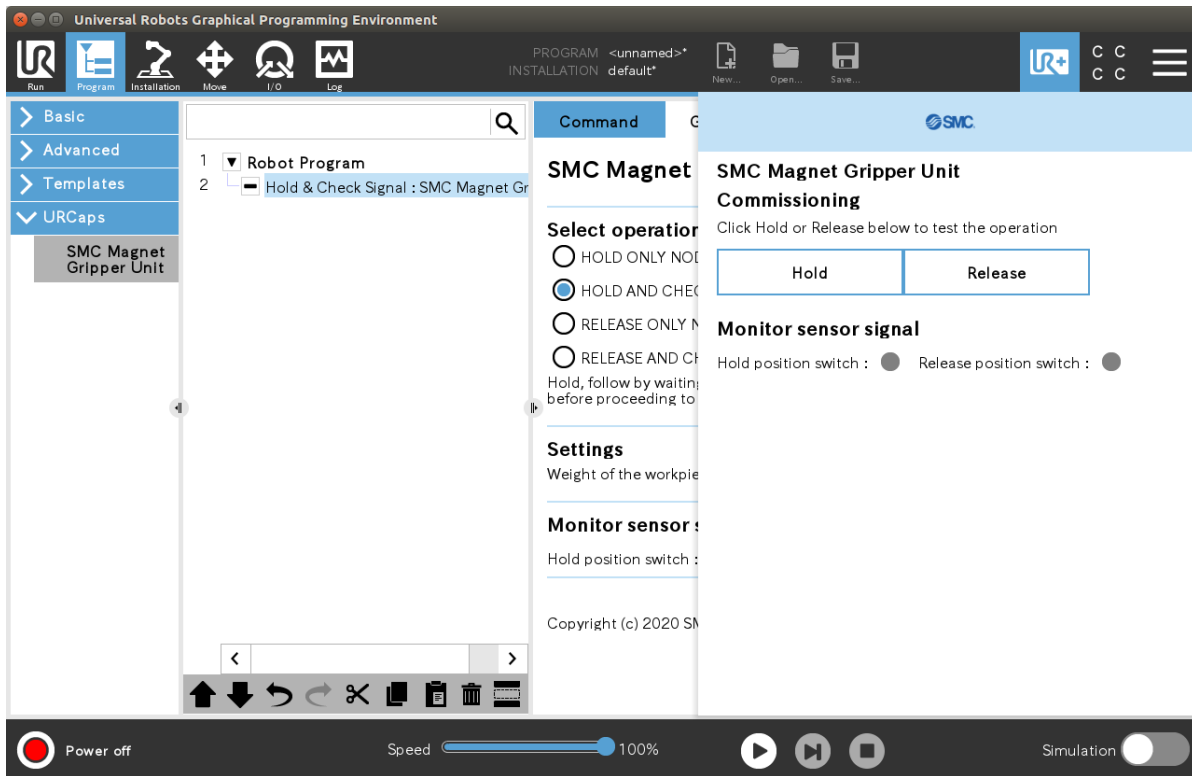

5-4. Air supply

Warning

1. Type of fluids

Please consult with SMC when using the product in applications other than compressed air.

2. When there is a large amount of drainage

Compressed air containing a large amount of drainage can cause the malfunction of pneumatic equipment. An air dryer or water separator should be installed upstream from filters.

3. Drain flushing

If condensation in the drain bowl is not emptied on a regular basis, the bowl will overflow and allow the condensation to enter the compressed air lines. This causes the malfunction of pneumatic equipment. If the drain bowl is difficult to check and remove, the installation of a drain bowl with an auto drain option is recommended. For compressed air quality, refer to the SMC Best Pneumatics No. 6 catalog.

4. Use clean air.

Do not use compressed air that contains chemicals, synthetic oils that include organic solvents, salt, corrosive gases, etc., as it can cause damage or malfunction.

Caution

1. When extremely dry air is used as the fluid, degradation of the lubrication properties inside the equipment may occur, resulting in reduced reliability (or reduced service life) of the equipment. Please consult with SMC.

2. Install an air filter.

Install an air filter upstream near the valve. Select an air filter with a filtration size of 5 µm or smaller.

3. Take measures to ensure air quality, such as by installing an aftercooler, air dryer, or water separator.

Compressed air that contains a large amount of drainage can cause the malfunction of pneumatic equipment, such as air grippers. Therefore, take appropriate measures to ensure air quality, such as by providing an aftercooler, air dryer, or water separator.

4. Ensure that the fluid and ambient temperatures are within the specified range.

If the fluid temperature is 5°C or less, the moisture in the circuit could freeze, causing damage to the seals or equipment malfunction. Therefore, take appropriate measures to prevent freezing. For compressed air quality, refer to the SMC Best Pneumatics No. 6 catalog.

5. Precautionary measures against condensation

Moisture condensation can occur inside pneumatic systems due to a drop in temperatures caused by the piping or operating conditions. This can degrade or wash away grease, resulting in a shortened service life or a malfunction. For details, refer to the catalog "Precautionary measures against condensation in a pneumatic system" (CAT.P-E01-11).

5-5. Piping

Caution

1. Refer to the Fittings and Tubing Precautions (Best Pneumatics) for handling one touch fittings.

2. Before piping, blow air (flush) or clean the piping to remove any cutting chips, cutting oil, dust, etc.

5-6. Operating environment

Warning

1. Do not use in an atmosphere containing corrosive gases, chemicals, sea water, water, water steam, or where there is direct contact with any of these.

Refer to each construction drawing for information on the materials of air grippers.

2. Do not expose the product to direct sunlight for an extended period of time.

3. Do not use in a place subject to heavy vibration and/or shock.

4. Do not mount the product in locations where it is exposed to radiant heat.

5. Do not use in dusty locations or where water, oil, etc., splash on the equipment.

6. A decrease in the base oil of grease may be accelerated by the properties of the compressed air used in pneumatic equipment, the external environment, operating conditions, etc., and the resulting drop in lubricating performance may have an effect on the equipment's service life.

Caution

1. Internal lubricant or the base oil of grease may seep out of the cylinder depending on the operating conditions (an ambient temperature of 40°C or more, pressure retention, low-frequency actuation, etc.). Take great care when a clean environment is required.

5-7. Lubrication

Caution

Magnet gripper is lubricating non-lube type.

These cylinders have been lubricated for life at the factory and can be used without any further lubrication. However, in the event that it is additionally lubricated, be sure to use class 1 turbine oil (with no additives) ISO VG320. Do not use machine oil or spindle oil. Stopping lubrication later on may lead to a malfunction because the new lubricant will displace the original lubricant. Therefore, lubrication must be continued once it has been started. If turbine oil is used, refer to the corresponding Safety Data Sheet (SDS).

6. Maintenance or inspection

6-1. Maintenance or inspection

Warning

1. Perform maintenance and inspection according to the procedures indicated in the operation manual.

If handled improperly, human injury and/or malfunction or damage of machinery and equipment may occur.

2. **Maintenance work**

If handled improperly, compressed air can be dangerous. Assembly, handling, repair, and element replacement of pneumatic systems should be performed by a knowledgeable and experienced person.

3. **Drain flushing**

Remove drainage from air filters regularly.

4. **Removal of equipment, and supply/exhaust of compressed air**

Before components are removed, first confirm that measures are in place to prevent workpieces from dropping, run-away equipment, etc. Then, cut off the supply pressure and electric power, and exhaust all compressed air from the system using the residual pressure release function. When machinery is restarted, proceed with caution after confirming that appropriate measures are in place to prevent sudden movement.

6-2. Replacement part

1. Replace the pad using the following procedure.

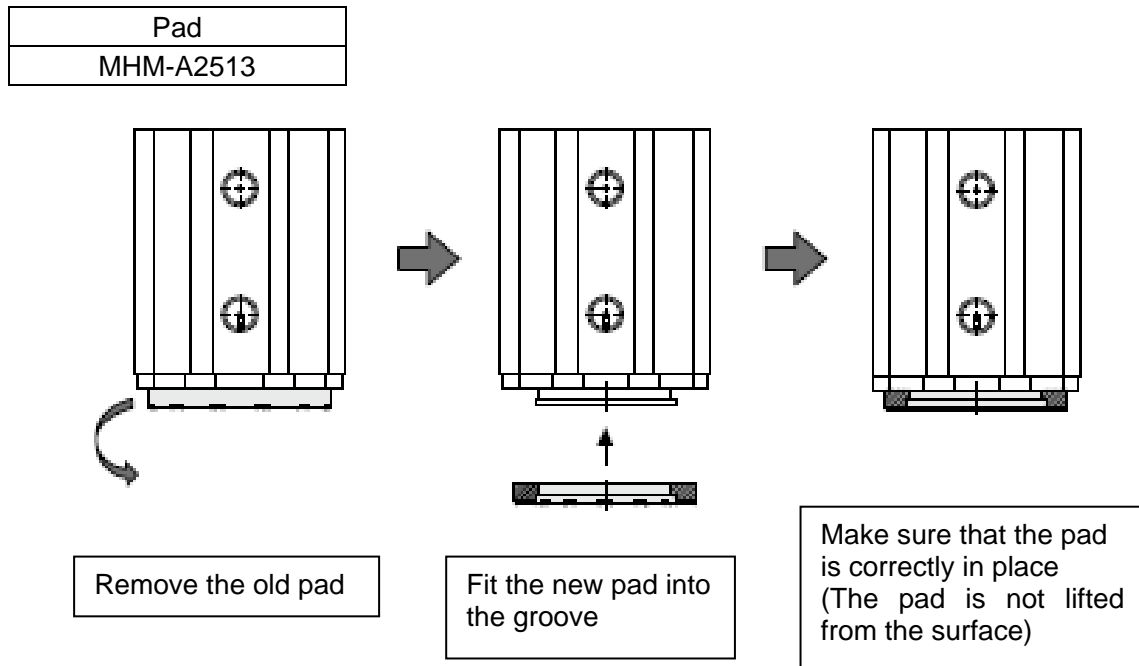

6-3. Maintenance



Warning

There is a strong magnet in the magnet gripper. Do not disassemble the product as the magnet may attract parts and peripheral objects which may cause an accident. When it is necessary to disassemble, please contact the SMC Sales representative.

Revision history

SMC Corporation

4-14-1, Sotokanda, Chiyoda-ku, Tokyo 101-0021 JAPAN

Tel: + 81 3 5207 8249 Fax: +81 3 5298 5362

URL <https://www.smcworld.com>

Note: Specifications are subject to change without prior notice and any obligation on the part of the manufacturer.
© 2019 SMC Corporation All Rights Reserved