



# Operation Manual

PRODUCT NAME

Air Gripper for Collaborative Robots

MODEL / Series / Product Number

JMHZ2-16D-\*-X7500AC-KA

**SMC Corporation**

# Contents

Safety Instructions .....	- 2 -
1. List of included items .....	- 4 -
2. Parts description of the air gripper .....	- 5 -
3. Product Specifications.....	- 6 -
3-1. How to order .....	- 6 -
3-2. Specifications .....	- 6 -
3-3. Auto switch .....	- 7 -
3-4. Gripping force.....	- 8 -
3-5. Gripping point.....	- 9 -
3-6. Dimensions .....	- 10 -
3-7. Air Gripper Single Unit .....	- 11 -
3-8. Center of gravity .....	- 12 -
4. Product Specifications.....	- 13 -
4-1. Attachment .....	- 13 -
4-2. Protection cover .....	- 14 -
4-3. Mounting to duAro flange .....	- 15 -
4-4. Angle Adjustment of the Moving Direction of the Finger.....	- 16 -
4-5. Piping .....	- 17 -
4-6. Speed controller .....	- 17 -
4-7. Finger open / close speed adjustment.....	- 18 -
4-8. Connection of the auto switch and sensor harness.....	- 19 -
5. Operating method or operation.....	- 19 -
5-1. Precautions for Design.....	- 19 -
5-2. Air supply .....	- 19 -
5-3. Operating environment .....	- 20 -
5-4. Lubrication .....	- 20 -
6. Maintenance .....	- 20 -



# Safety Instructions

These safety instructions are intended to prevent hazardous situations and/or equipment damage. These instructions indicate the level of potential hazard with the labels of "Caution," "Warning" or "Danger." They are all important notes for safety and must be followed in addition to International Standards (ISO/IEC)\*1), and other safety regulations.

\*1) ISO 4414: Pneumatic fluid power -- General rules relating to systems.

ISO 4413: Hydraulic fluid power -- General rules relating to systems.

IEC 60204-1: Safety of machinery -- Electrical equipment of machines.(Part 1: General requirements)

ISO 10218: Manipulating industrial robots -Safety.

etc.



## Caution

**Caution** indicates a hazard with a low level of risk which, if not avoided, could result in minor or moderate injury.

## Warning

**Warning** indicates a hazard with a medium level of risk which, if not avoided, could result in death or serious injury.

## Danger

**Danger** indicates a hazard with a high level of risk which, if not avoided, will result in death or serious injury.

## Warning

### **1. The compatibility of the product is the responsibility of the person who designs the equipment or decides its specifications.**

Since the product specified here is used under various operating conditions, its compatibility with specific equipment must be decided by the person who designs the equipment or decides its specifications based on necessary analysis and test results.

The expected performance and safety assurance of the equipment will be the responsibility of the person who has determined its compatibility with the product.

This person should also continuously review all specifications of the product referring to its latest catalog information, with a view to giving due consideration to any possibility of equipment failure when configuring the equipment.

### **2. Only personnel with appropriate training should operate machinery and equipment.**

The product specified here may become unsafe if handled incorrectly.

The assembly, operation and maintenance of machines or equipment including our products must be performed by an operator who is appropriately trained and experienced.

### **3. Do not service or attempt to remove product and machinery/equipment until safety is confirmed.**

1. The inspection and maintenance of machinery/equipment should only be performed after measures to prevent falling or runaway of the driven objects have been confirmed.

2. When the product is to be removed, confirm that the safety measures as mentioned above are implemented and the power from any appropriate source is cut, and read and understand the specific product precautions of all relevant products carefully.

3. Before machinery/equipment is restarted, take measures to prevent unexpected operation and malfunction.

### **4. Contact SMC beforehand and take special consideration of safety measures if the product is to be used in any of the following conditions.**

1. Conditions and environments outside of the given specifications, or use outdoors or in a place exposed to direct sunlight.

2. Installation on equipment in conjunction with atomic energy, railways, air navigation, space, shipping, vehicles, military, medical treatment, combustion and recreation, or equipment in contact with food and beverages, emergency stop circuits, clutch and brake circuits in press applications, safety equipment or other applications unsuitable for the standard specifications described in the product catalog.

3. An application which could have negative effects on people, property, or animals requiring special safety analysis.

4. Use in an interlock circuit, which requires the provision of double interlock for possible failure by using a mechanical protective function, and periodical checks to confirm proper operation.



# Safety Instructions

## Caution

### **The product is provided for use in manufacturing industries.**

The product herein described is basically provided for peaceful use in manufacturing industries. If considering using the product in other industries, consult SMC beforehand and exchange specifications or a contract if necessary.  
If anything is unclear, contact your nearest sales branch.

## **Limited warranty and Disclaimer/Compliance Requirements**

The product used is subject to the following “Limited warranty and Disclaimer” and “Compliance Requirements”.

Read and accept them before using the product.

### **Limited warranty and Disclaimer**

- 1. The warranty period of the product is 1 year in service or 1.5 years after the product is delivered, whichever is first. □2)**  
Also, the product may have specified durability, running distance or replacement parts. Please consult your nearest sales branch.
- 2. For any failure or damage reported within the warranty period which is clearly our responsibility, a replacement product or necessary parts will be provided.**  
This limited warranty applies only to our product independently, and not to any other damage incurred due to the failure of the product.
- 3. Prior to using SMC products, please read and understand the warranty terms and disclaimers noted in the specified catalog for the particular products.**  
□□2) Vacuum pads are excluded from this 1 year warranty.  
A vacuum pad is a consumable part, so it is warranted for a year after it is delivered.  
Also, even within the warranty period, the wear of a product due to the use of the vacuum pad or failure due to the deterioration of rubber material are not covered by the limited warranty.

### **Compliance Requirements**

- 1. The use of SMC products with production equipment for the manufacture of weapons of mass destruction(WMD) or any other weapon is strictly prohibited.**
- 2. The export of SMC products or technology from one country to another is governed by the relevant security laws and regulations of the countries involved in the transaction. Prior to the shipment of an SMC product to another country, ensure that all local rules governing that export are known and followed.**

## Caution

### **SMC products are not intended for use as instruments for legal metrology.**

Measurement instruments that SMC manufactures or sells have not been qualified by type approval tests relevant to the metrology (measurement) laws of each country.

Therefore, SMC products cannot be used for business or certification ordained by the metrology (measurement) laws of each country.

# 1. List of included items

- Air gripper 1pc.

\*The appearance of the air gripper differs depending on the part number.  
For the product number, see section 3-1. How to order (P.6).

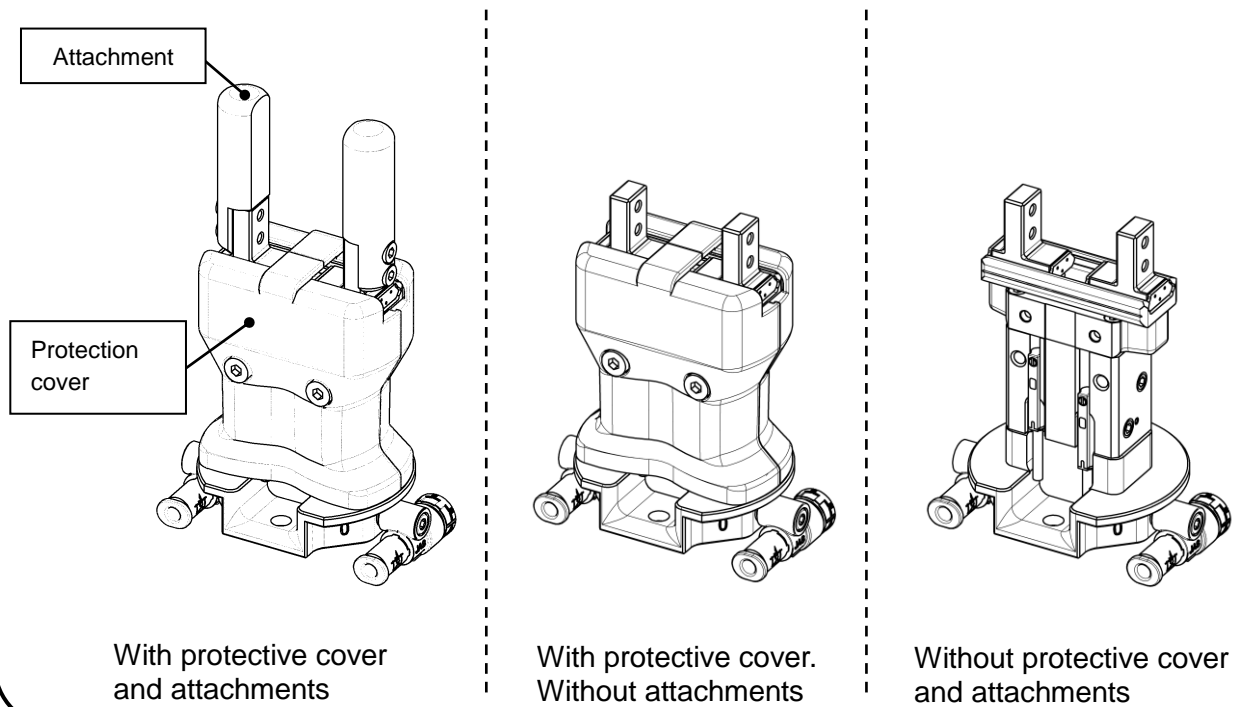

- Accessories

Used for mounting this product and duAro flange. Refer to 4-3. Mounting to duAro flange (P.15).

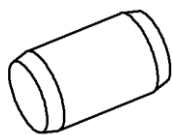

Positioning pin (5x10) 1pc.

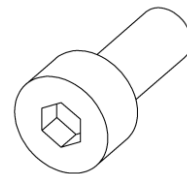

Hexagon socket head cap screw (M5x10) 2 pcs.

## 2. Parts description of the air gripper

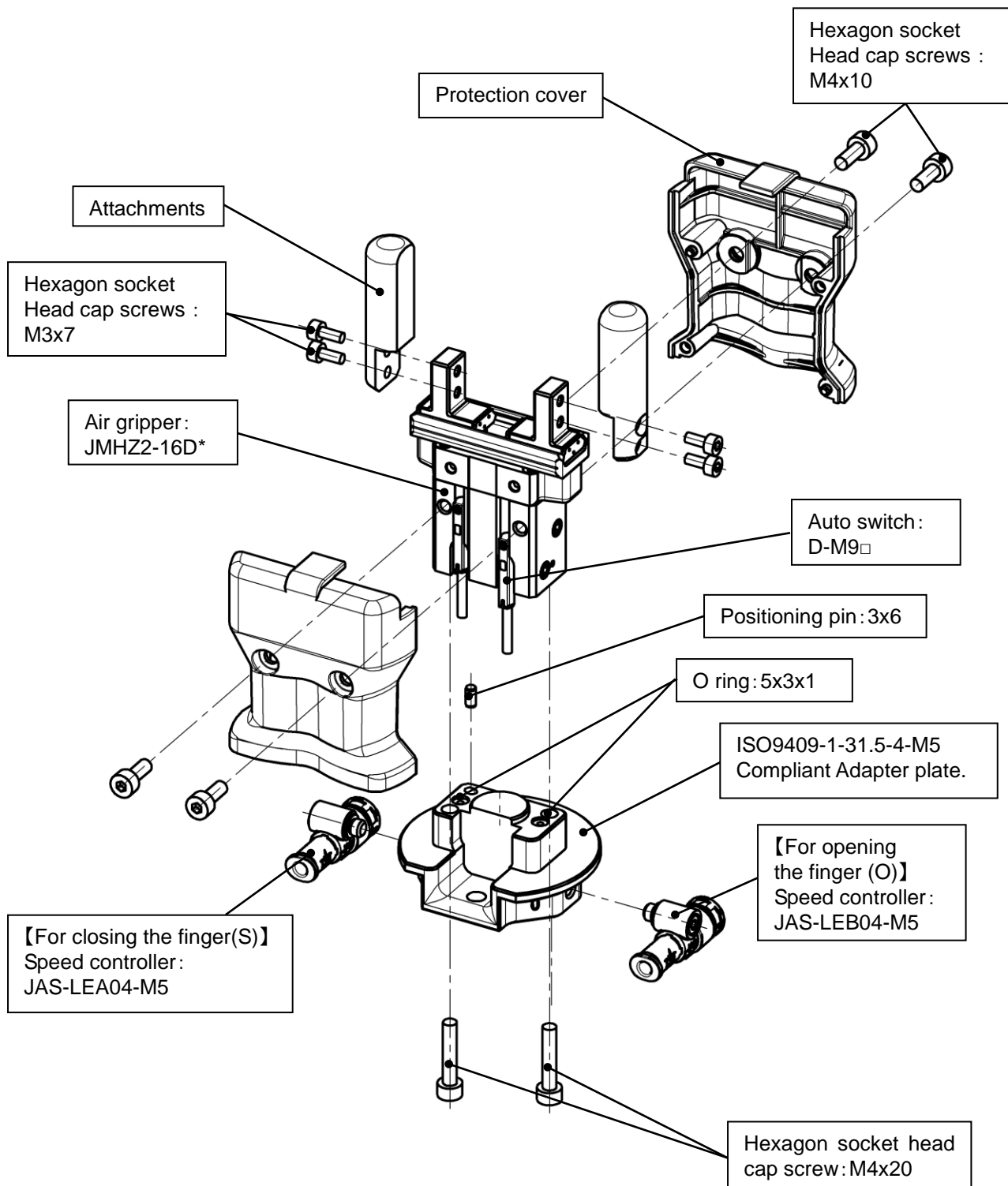

\* This drawing shows “with protective cover and attachments”.

# 3. Product Specifications

## 3-1. How to order

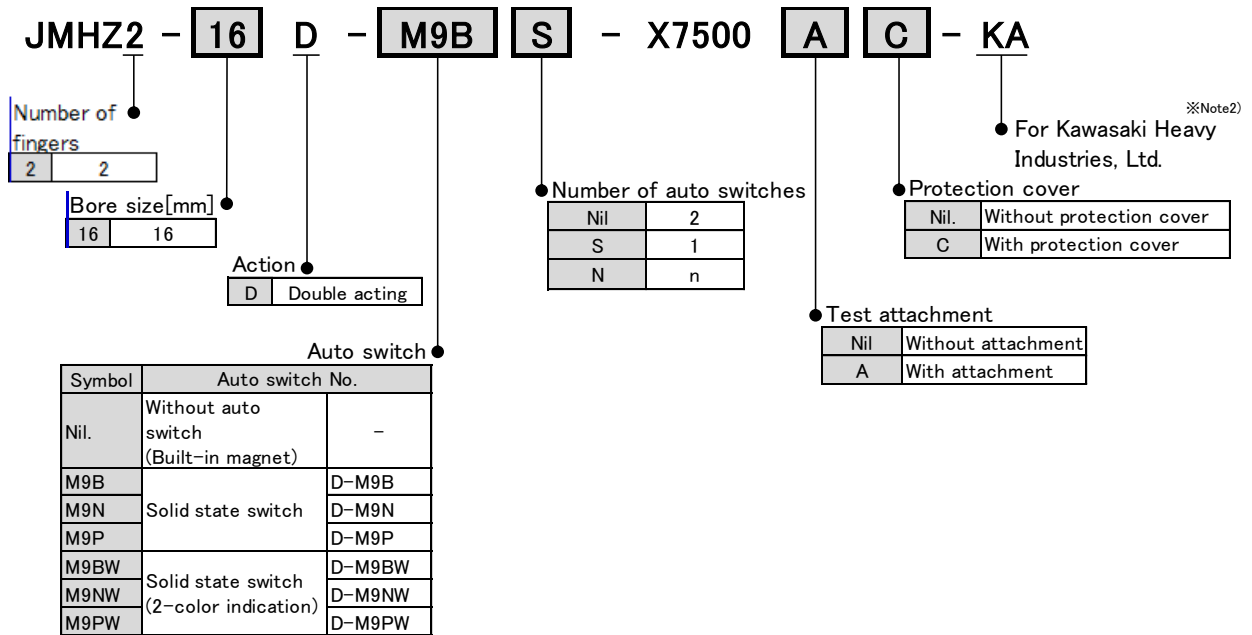

\*Note 1) lead wire length symbols

- 0.5m · · · Nil. (Case) M9NW
- 1m · · · M (Case) M9NWM
- 3m · · · L (Case) M9NWL
- 5m · · · Z (Case) M9NWZ

\*Note 2) When 2 auto-switches are specified they are assembled for shipping. Otherwise, the switch(es) is/are included in the package separately.  
 duAro1 · duAro2 · RS003N · RS005N · RS005L · RS007N · RS007L

## 3-2. Specifications

### Specifications

Cylinder inside diameter (mm)		16
Fluid		Air
Operating pressure (MPa)		0.1 to 0.7
Ambient and operating fluid temperature(°C)		-10 to 60
Repeatability (mm)		±0.01
Maximum operating frequency (c.p.m.)		120
Lubrication		Non-lube
Operating method		Double acting
Gripping force Actual value per finger (N)	External gripping force	32.7
	Internal Gripping force	43.5
Opening/ closing stroke (both sides) (mm)		10
Weight (g)		230 *Note2

\*Note 2) This value excludes the weight of the attachments 2pcs : Approx. 30g and protective cover 2pcs : approx. 20g.

### 3-3. Auto switch

#### Specifications

D-M9□(With indicator light)						
Auto switch model	D-M9B	D-M9N	D-M9P	D-M9BW	D-M9NW	D-M9PW
Electrical entry direction	In-line					
Wiring	2-wire	3-wire		2-wire	3-wire	
Output	-	NPN type	PNP type	-	NPN type	PNP type
Applicable load	DC24V Relay PLC	IC circuit,Relay,PLC		DC24V Relay PLC	IC circuit,Relay,PLC	
Power supply voltage	-	DC5·12·24V(4.5 to 28V)		-	DC5·12·24V(4.5 to 28V)	
Current consumption	-	10mA or less		-	10mA or less	
Load voltage	DC24 (DC10 to 28V)	DC28V or less	-	DC24 (DC10 to 28V)	DC28V or less	-
load current	2.5 to 40mA	40mA or less		2.5 to 40mA	40mA or less	
Internal voltage drop	4V or less	0.8 V or less at 10 mA (2 V or less at 40 mA)		4V or less	0.8 V or less at 10 mA (2 V or less at 40 mA)	
Current leakage	0.8mA or less	100μA or less at 24 VDC		0.8mA or less	100μA or less at 24 VDC	
Indicator LED	Red LED illuminates when turned ON.			Operating range ----- Red LED ON Correct operating range ---- Green LED ON		
Standard	CE marking, RoHS					

#### Dimensions

##### D-M9□

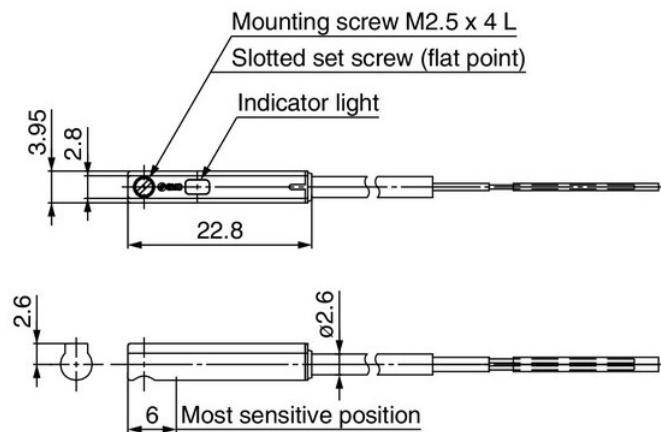

- \*The sensing position of the auto switch is fixed to the open end and closed end of the finger.
- \* When detecting the gripping position of the workpiece, secure the auto switch at the appropriate position according to the shape of the workpiece.
- \* For examples of setting auto switch and setting of mounting position of auto switches, please refer to the JMHZ2 Series catalogue P.15 onwards on our website ([www.smcworld.com](http://www.smcworld.com)).

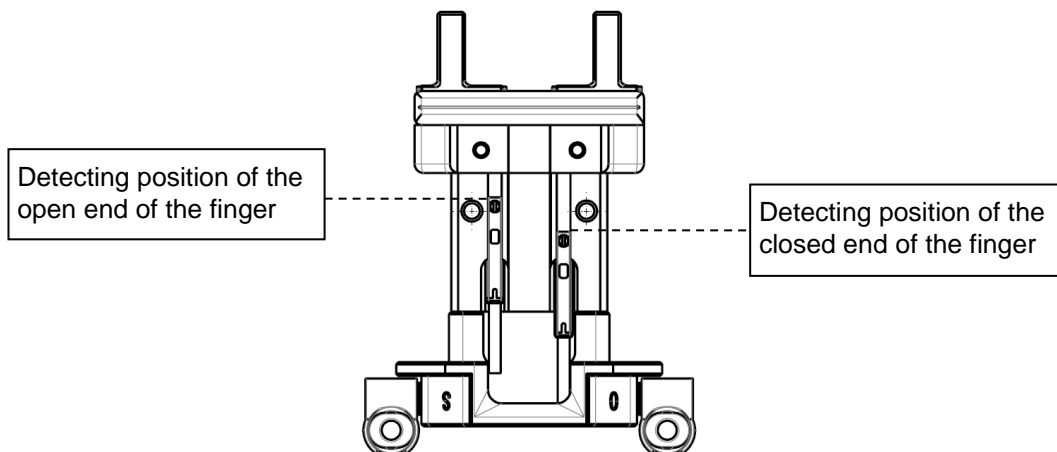



### 3-4. Gripping force

The gripping force shown in the graph to the right represents the gripping force of one finger when all fingers and attachments are in contact with the workpiece.

#### External gripping state.

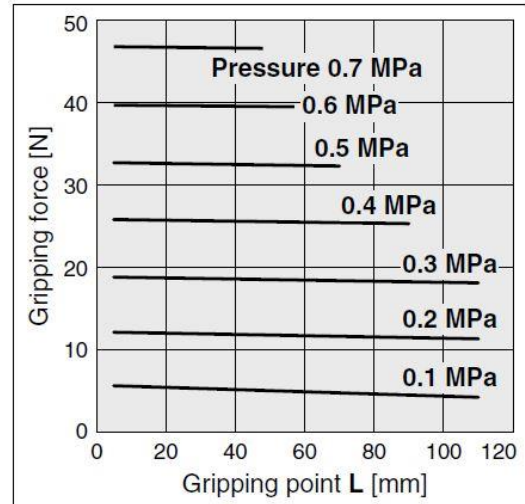
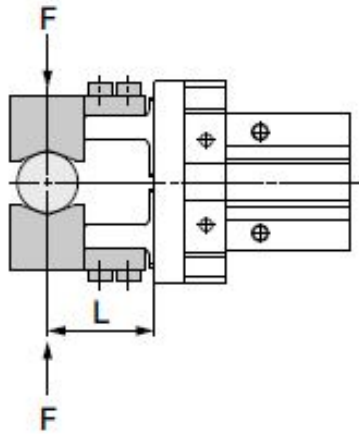

#### Internal gripping state.

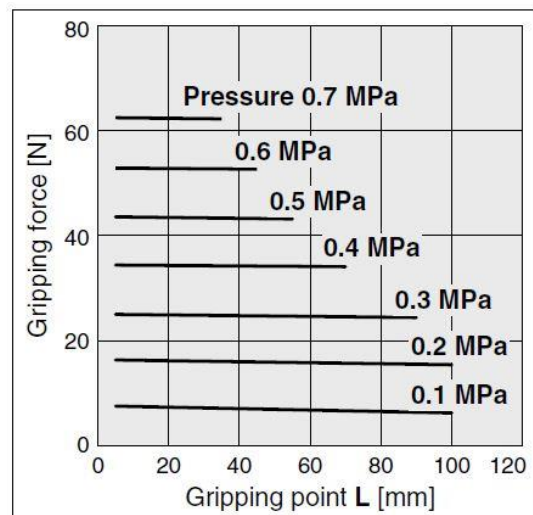
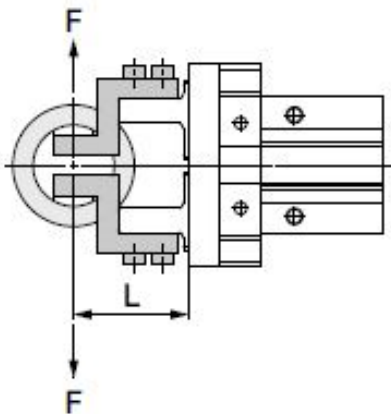

### 3-5. Gripping point

The air gripper should be operated so that the workpiece gripping point “L” and the amount of overhang “H” stay within the range shown for each operating pressure given in the graphs to the right. If the workpiece gripping point goes beyond the range limits, this will have an adverse effect on the life of the air gripper.

#### External gripping state

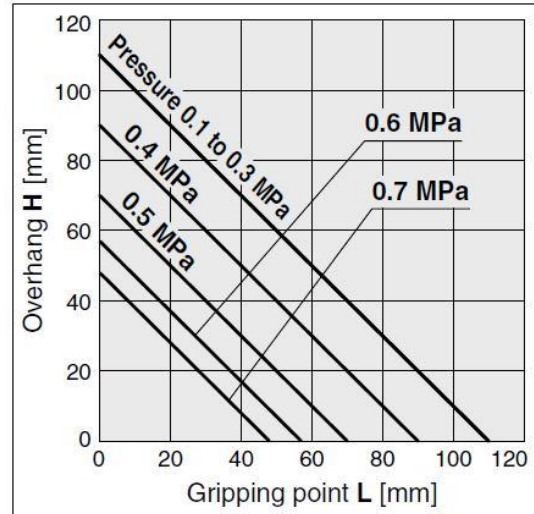
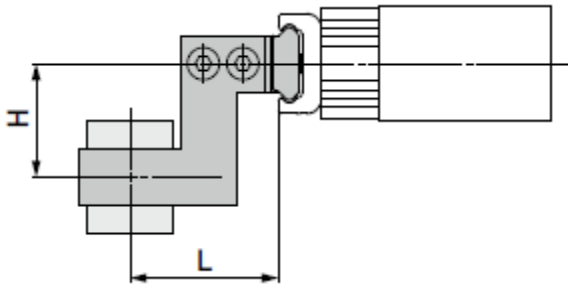

#### Internal gripping state

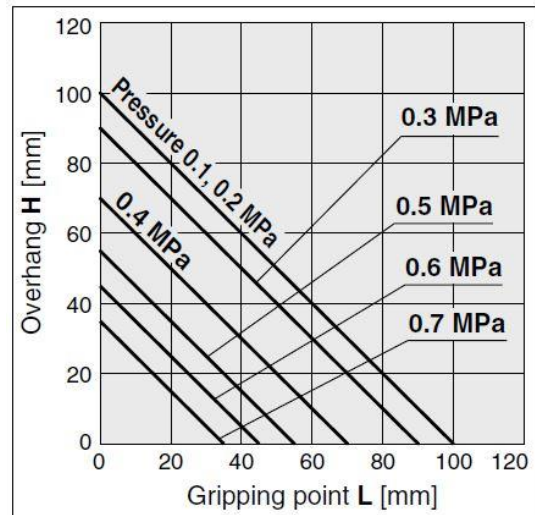
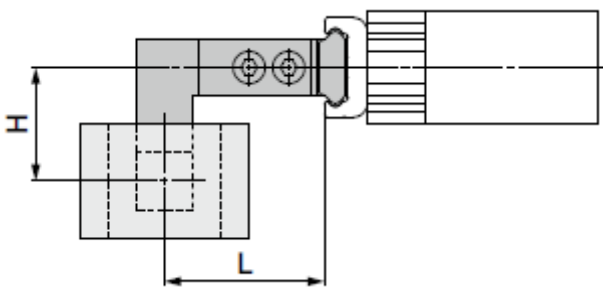



### 3-7. Air Gripper

The drawings below show the external dimensions of the air gripper built into the product. Refer to the drawings below if attachments are prepared by the user. The specifications of the single unit of the air gripper are the same as the specifications in P.6, 3-2. Specifications.

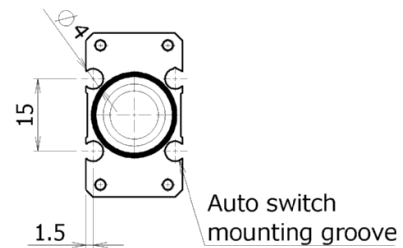
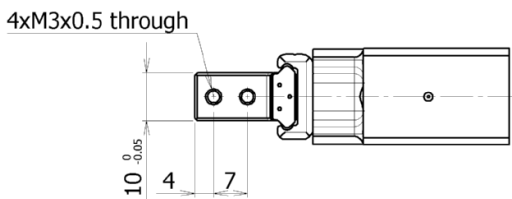
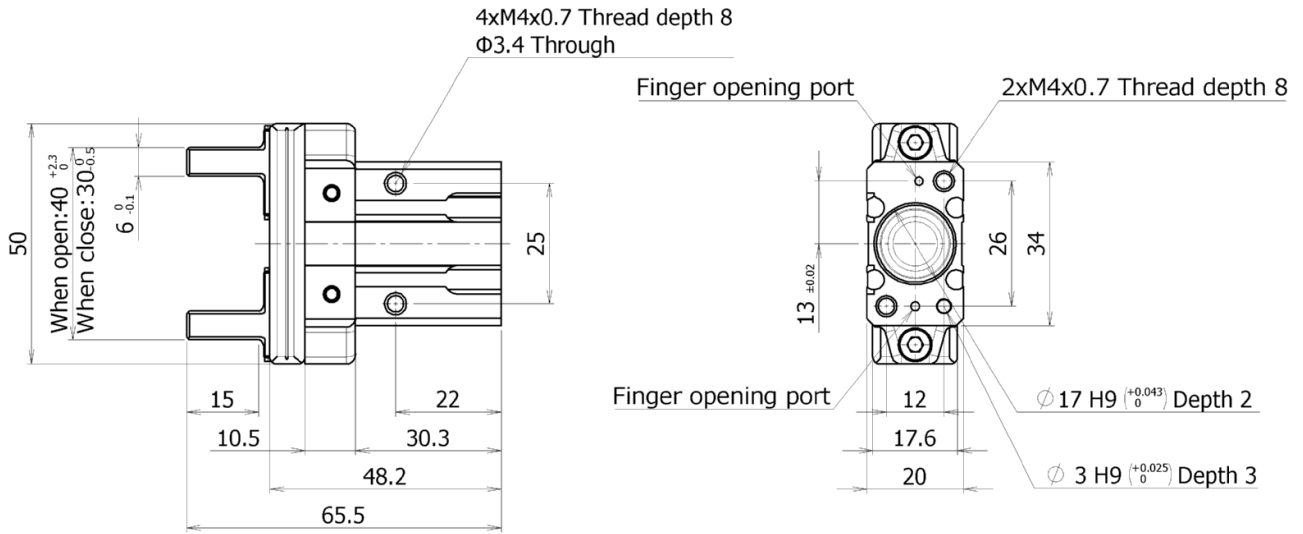

### ⚠ Caution

\* For detailed specifications not included in this document, please refer to the our website ([www.smcworld.com](http://www.smcworld.com)) or operation manual.

The air gripper in this product has a special specification with a different piping direction from the standard product. Therefore, it is not interchangeable with the SMC standard JMHZ2-16D. Contact SMC sales representative in case of malfunction or maintenance.

### 3-8. Center of gravity

The centre of gravity of the product is shown below. Adjust the position of the center of gravity with the robot controller.

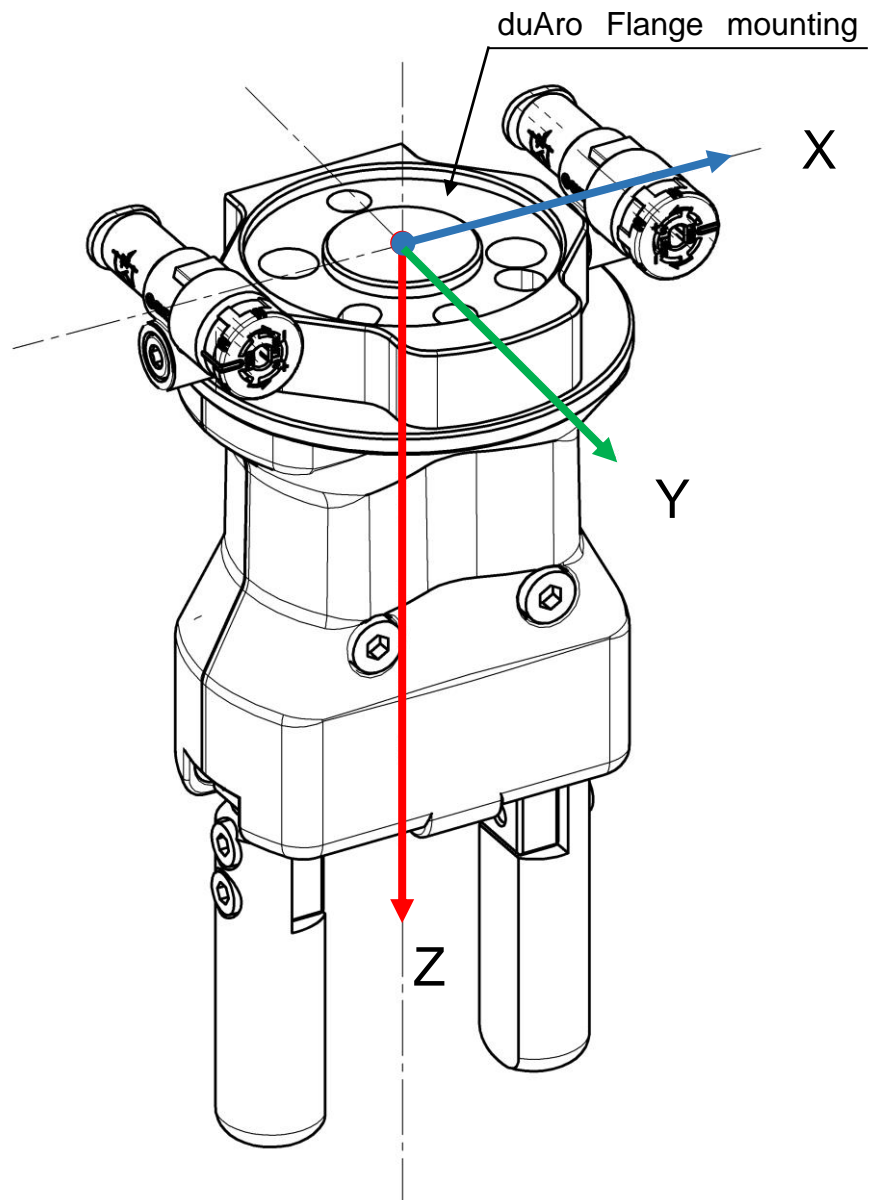

Center of gravity		
X	Y	Z
0.1	0.8	44.7

## 4. Product Specifications

### Warning

1. Install and operate the product only after reading the Operation Manual carefully and understanding its contents. Also, keep the manual where it can be referred to as necessary.
2. When installing the products, allow access for maintenance.
3. Do not scratch or dent the air gripper by dropping or bumping it when mounting. Slight deformation can cause inaccuracies or a malfunction.
4. Tighten the screw within the specified torque range when mounting the attachment.  
Tightening with a torque above the limit can cause malfunction, while insufficient tightening can cause slippage and dropping.

### 4-1. Attachment

Attachment for testing is included in the product. For mounting and removal of the attachment, refer to the drawing below. When tightening, fix the finger attachment with a tool such as a spanner so that the load is not directly applied to the guide while tightening.

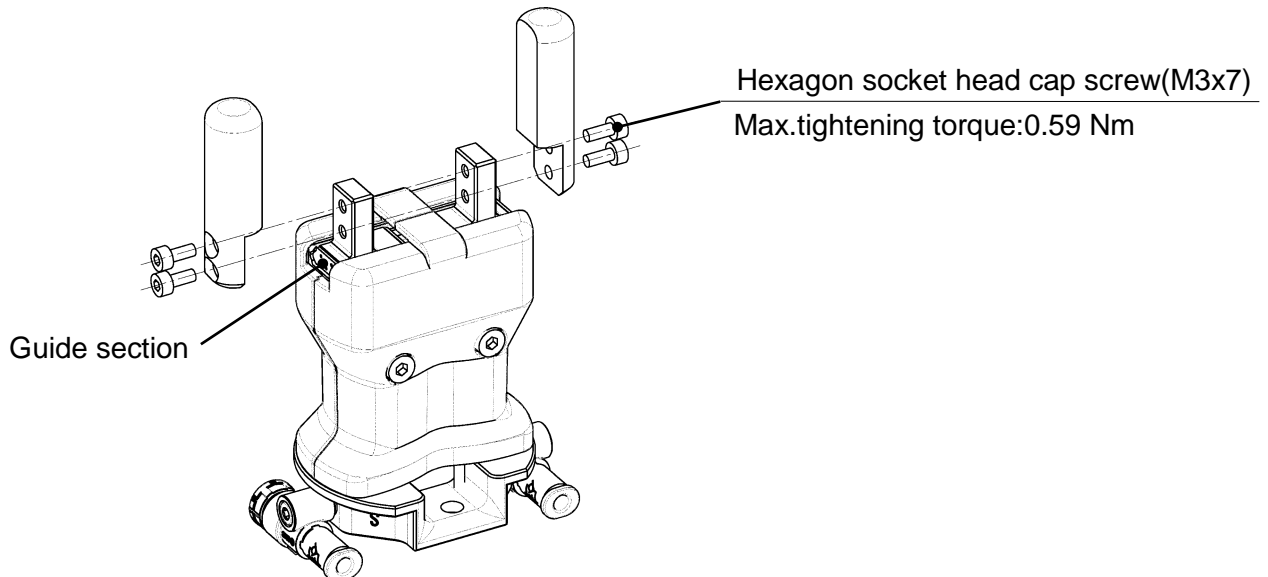

Make sure to mount the attachments on fingers with the tightening torque in the table below by using bolts, etc., for the female threads on fingers.

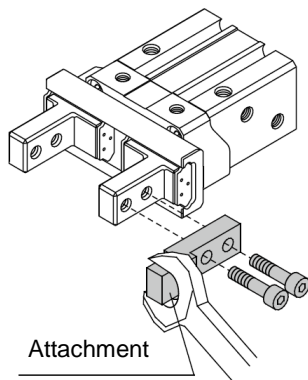

Model	Bolt	Max.tightening Torque (Nm)
JMHZ2-16D	M3x0.5	0.59

## 4-2. Protection cover

For mounting and removal of the protective cover, refer to the drawing below. Take care not to get the switch cable caught when mounting the cover.

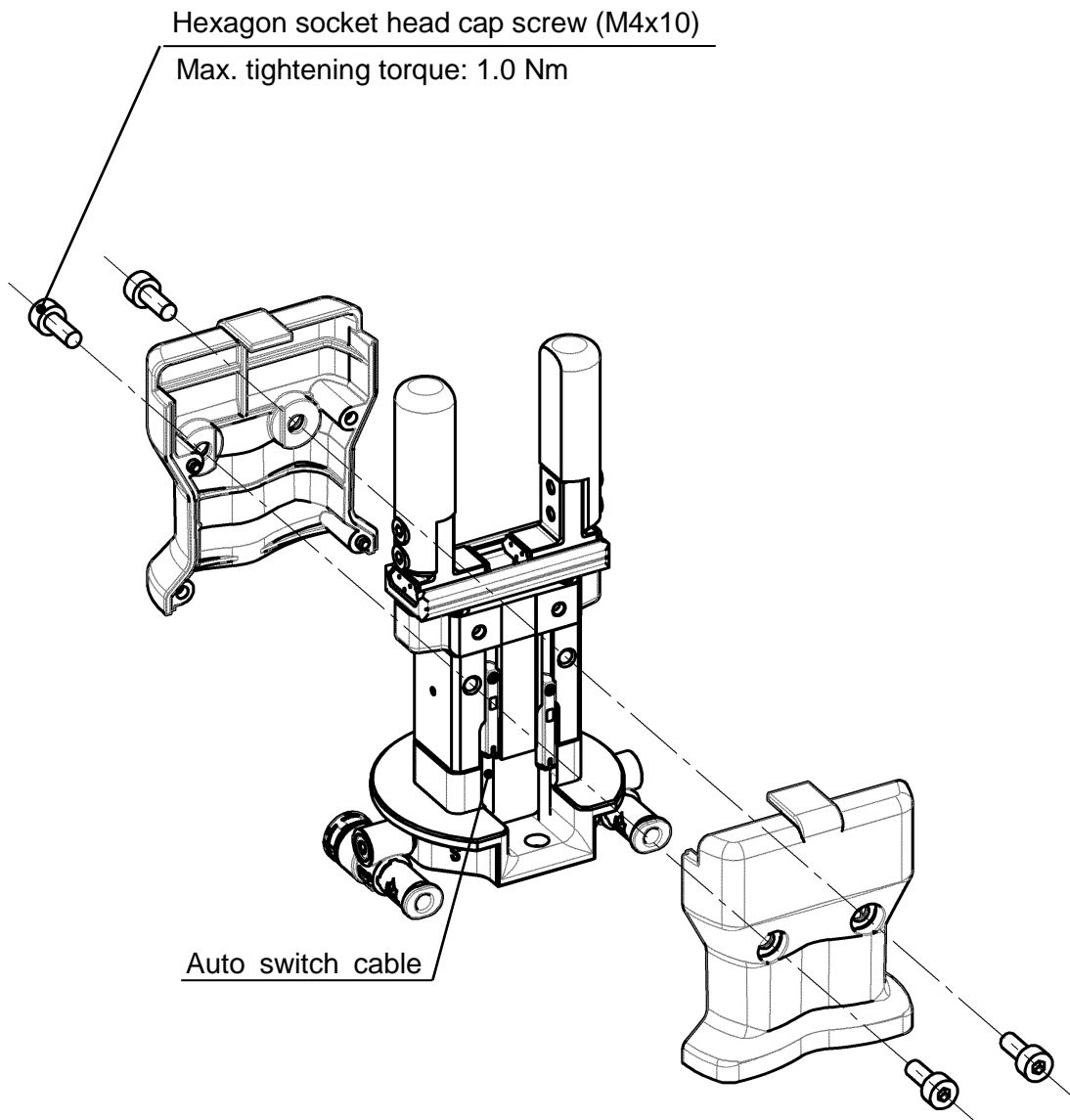

### 4-3. Mounting to duAro flange

Mount the duAro flange using the bolts in the accessory as shown below.

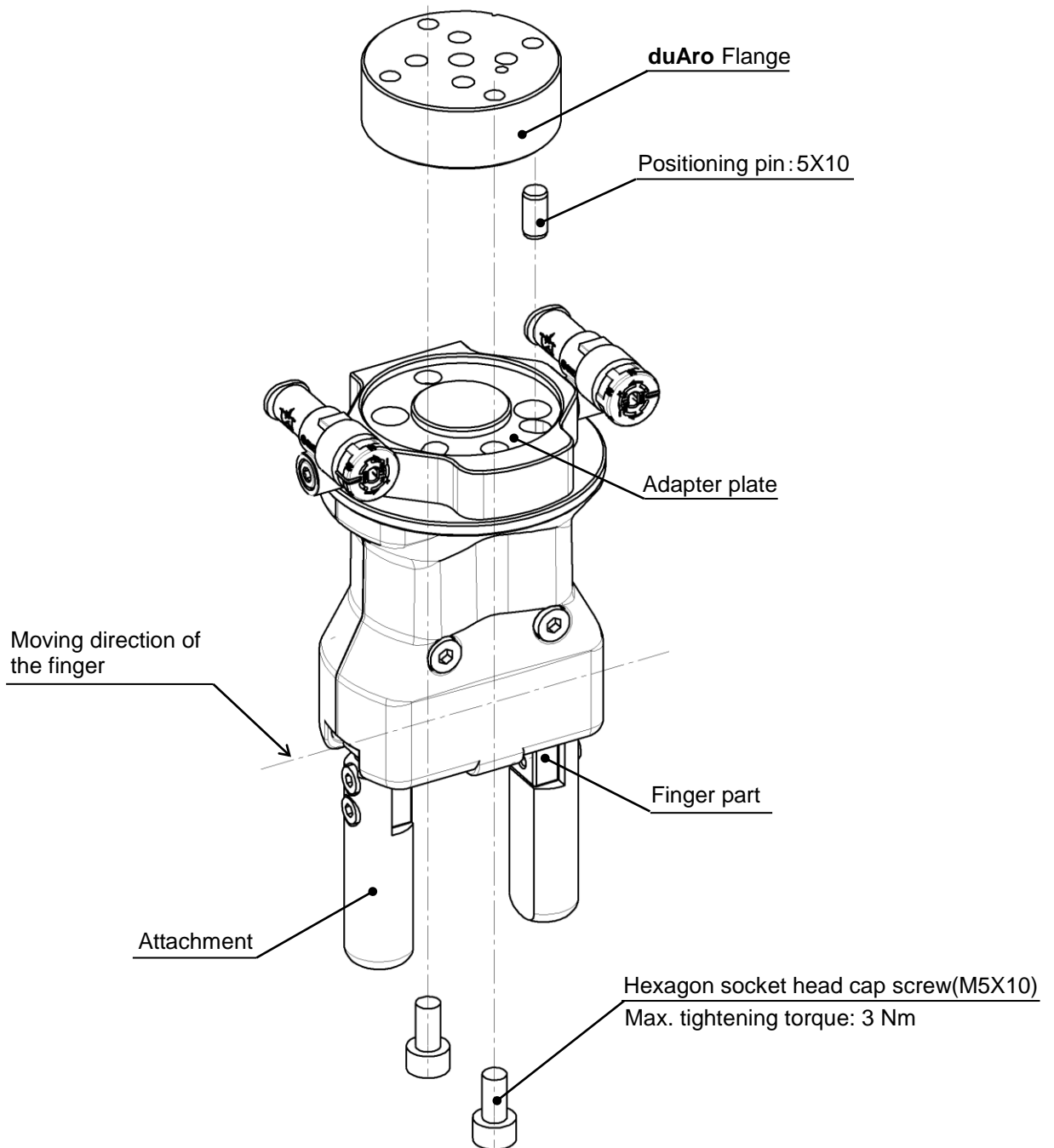

#### **Caution**

The adapter plate of this product has two positioning pin holes. The moving direction of the finger can be changed by 90 degree depending on the mounting position. After determining the mounting position, correct the angle of the moving direction of the finger on the duAro if necessary. (4- 4. Angle Adjustment of the Moving Direction of the Finger)





## 4-5. Piping

Based on the dimensions of this product, connect the tube with an appropriate diameter to each air supply port.

For the connection between this product and the air tubing coming out of the duAro arm, refer to the Operation manual of the duAro.

## 4-6. Speed controller:

A push-lock type one-touch speed controller is fitted in each port to control speed in each direction of travel.. Refer to **P. 18** for the product number of the speed controller.

### **Caution**

1. Speed controller is provided with a retaining mechanism.
2. Make sure that the push-lock handle (hereinafter referred to as handle) is locked. When the orange mark is visible, the speed controller is unlocked.

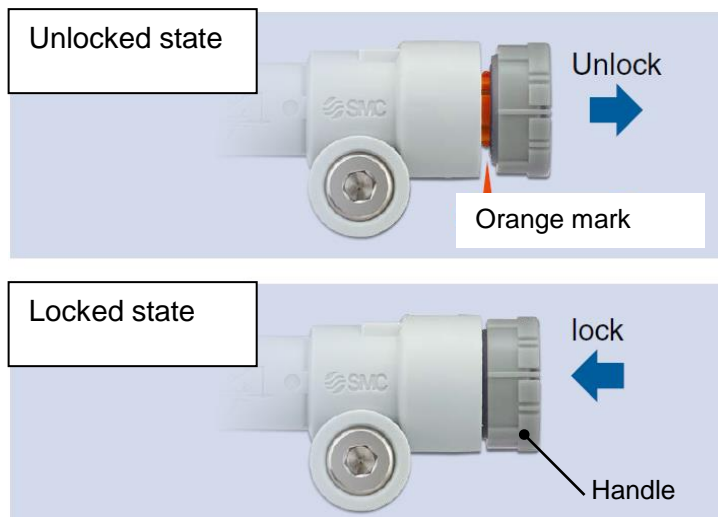

3. When the speed controller is unlocked, the set speed may change.
4. If the handle is pulled with force while the speed controller is unlocked, it may result in breakage.  
When it is unlocked, do not pull the handle out with force.
5. To adjust the speed, start with the handle in the closed position, and then adjust by opening gradually.
6. Too much rotation of the handle will cause damage.  
The number of rotations of the handle is 4 from the fully closed position

### **Caution**

1. Refer to the Fittings and Tubing Precautions (Best Pneumatics) for the speed controller with one-touch fitting push lock type.

#### **2. Before piping**

Before piping is connected, it should be thoroughly flushed with air or washed to remove chips, cutting oil and other debris from inside the pipe.

## 4-7. Finger open / close speed adjustment

After setting the piping and supply pressure, adjust the finger opening / closing speed.

Adjust the finger opening / closing speed by turning the handle of each speed controller shown in the figure below.

The needle closes with a clockwise rotation and opens with a counterclockwise rotation meaning that the finger speed becomes slower with clockwise rotation and faster with counterclockwise rotation.

Confirm that the handle is locked by pushing the handle after adjusting the opening / closing speed of the finger.

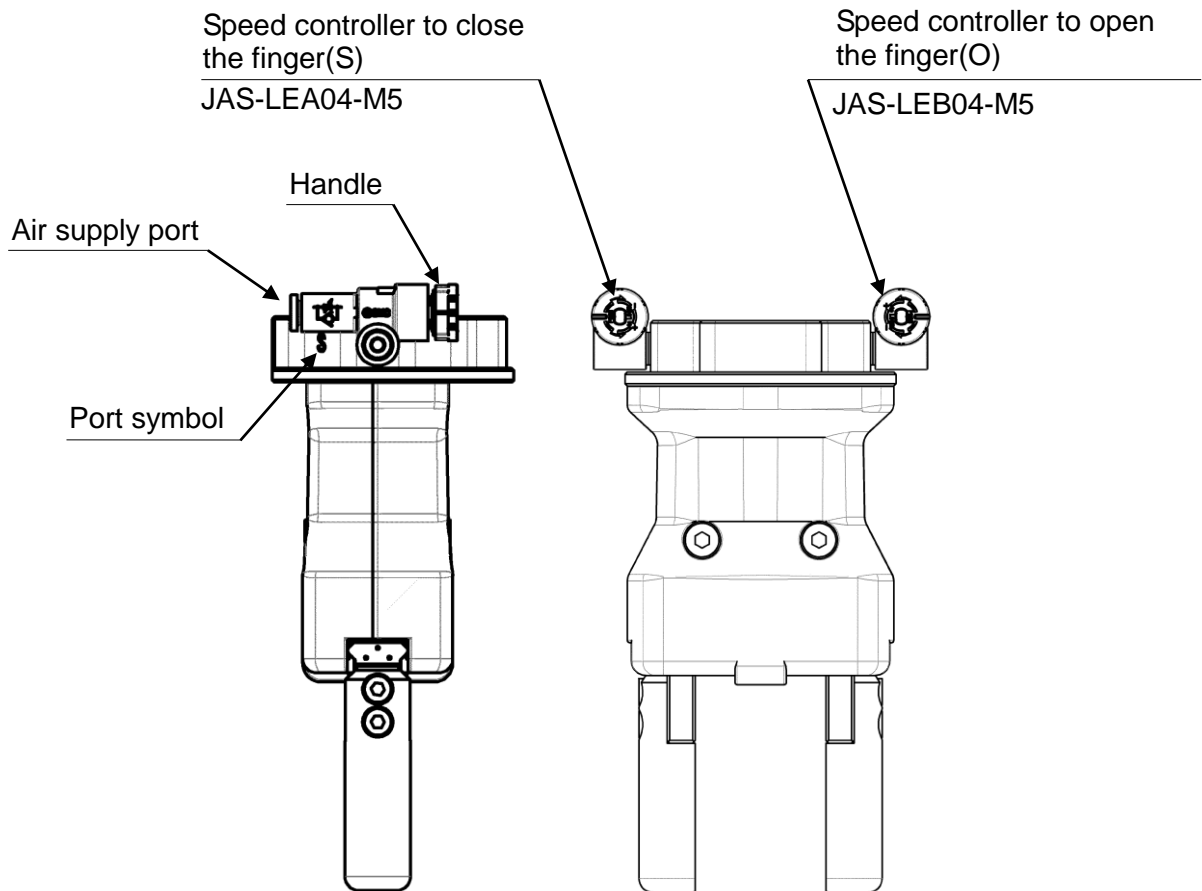

## 4-8. Connection of the auto switch and sensor harness

For the wiring connection between the sensor harness on the duAro arm and each auto switch of this product, refer to the operation manual of the duAro main unit.  
See also JMHZ2 Series Catalogue P.18 Auto Switch connections and Examples.

## 5. Operating method or operation

---

### 5-1. Precautions for Design

#### Warning

1. The product is designed for use only in compressed air systems. Do not operate at pressures or temperatures, etc., beyond the range of the specifications, as this can cause damage or malfunction of the cylinder and other equipment. (Refer to the specifications.)  
Please contact SMC if using fluids other than compressed air. The product cannot be guaranteed if is used outside of the specification range.
2. Take safety measures (e.g. mounting protective covers) when there is a danger of fingers being caught in a gripper or workpieces causing damage, etc.
3. There is a danger of workpieces dropping if there is a decrease in gripping force due to a drop in circuit pressure caused by a power failure, etc. It is necessary to take measures such as drop prevention so that injury and damage to machinery or equipment can be prevented.
4. If the product is used for a purpose other than the transportation of a workpiece such as positioning or clamping, please consult SMC.

#### Caution

1. Finite orbit type guide is used in the actuator finger part. By using this, when there are inertial force which cause by movements or rotation to the actuator, steel ball will move to one side and this will cause a large resistance degrade the accuracy. When there are inertial force which cause by movements or rotation to the actuator, operate the finger to full stroke.

### 5-2. Air supply

#### Warning

1. Please contact SMC when using the product in applications other than with compressed air.
2. Compressed air containing a large amount of drainage can cause the malfunction of pneumatic equipment. An air dryer or water separator should be installed upstream from filters.
3. If condensation in the drain bowl is not emptied on a regular basis, the bowl will overflow and allow the condensation to enter the compressed air lines. This causes the malfunction of pneumatic equipment. If the drain bowl is difficult to check and remove, the installation of a drain bowl with an auto drain option is recommended.
4. Use clean air.  
Do not use compressed air that contains chemicals, synthetic oils including organic solvents, salt or corrosive gases, etc., as it can cause damage or malfunction of equipment.  
For detailed information regarding the quality of the compressed air described above, refer to SMC's "Air Cleaning Systems".

#### Caution

1. When dry air is used as the fluid, degradation of the lubrication properties inside the equipment may occur, resulting in reduced reliability (or reduced service life) of the equipment. Please consult with SMC.
2. Install air filters.  
Install an air filter at the upstream side of valve. Select an air filter with a filtration degree of 5µm or finer.

3. Install an aftercooler, air dryer or drain catch before the filter and take appropriate measures.  
Compressed air that contains excessive foreign material may cause malfunction of valves and other pneumatic equipment.  
Therefore, take appropriate measures to ensure air quality, such as by providing an aftercooler, air dryer or water separator.
4. Use the product within the specified fluid and ambient temperature range.  
If the fluid temperature is 5°C or Cable at the bottom, the moisture in the circuit could freeze, causing damage to the seals and leading to equipment malfunction. Therefore, take appropriate measures to prevent freezing.

For detailed information regarding the quality of the compressed air described above, refer to SMC's "Air Cleaning Systems".

### 5-3. Operating environment

#### **Warning**

1. Do not use in an atmosphere where corrosive gases, chemicals, sea water, water or water steam is present.
2. Do not expose the product to direct sunlight for an extended period of time.
3. Do not operate in a location subject to vibration or impact.
4. Do not mount the product in locations where it is exposed to radiant heat.
5. Do not use this product in an area that is dusty, or in an environment in which water or oil splashes on to the cylinder.

#### **Caution**

1. Martensitic stainless steel is used for the finger guide rail, so make sure that anti-corrosiveness is inferior to the austenitic stainless steel. Especially rust may be generated in environments that allow water drops from condensation to stay on the surface.

### 5-4. Lubrication

#### **Caution**

1. The non-lube type air gripper is lubricated at the factory, and can be used without any further lubrication.  
If a lubricant is used in the system, use turbine oil Class 1 (with no additive) ISO VG32.  
Furthermore, once lubrication is applied, it must be continued.  
If lubrication is later stopped, malfunction can occur due to loss of the original lubricant.  
Refer to the Material Safety Data Sheet (MSDS) of the hydraulic fluid when supplying the fluid.

## 6. Maintenance

---

#### **Warning**

1. If handled improperly, compressed air can be dangerous. The assembly, handling, repair and element replacement of pneumatic systems should be performed by a knowledgeable and experienced person.
2. Remove drainage from air filters regularly.
3. When air grippers are removed, first confirm that measures are in place to prevent any workpieces from dropping, run-away of equipment, etc. Then cut off the supply pressure and electric power and exhaust all compressed air from the system using the residual pressure release function.  
When the equipment is restarted, proceed with caution after confirming that appropriate measures are in place to prevent cylinders from sudden movement.
4. Do not allow people to enter or place objects in the carrying path of the air gripper.  
Otherwise, injury or an accident may occur.

5. Do not put hands, etc. in between the air gripper fingers or attachments.  
Otherwise, injury or an accident may occur.
6. When removing the air gripper, first confirm that no workpieces are being held and then release the compressed air before removing the air gripper.  
If a workpiece is still being held, there is a danger of it being dropped.
7. If the auto switch needs to be replaced due to a failure, an auto switch product can be ordered separately and the user can replace it.

Revision history

# SMC Corporation

4-14-1, Sotokanda, Chiyoda-ku, Tokyo 101-0021 JAPAN

Tel: + 81 3 5207 8249 Fax: +81 3 5298 5362

URL <https://www.smcworld.com>

---

Note: Specifications are subject to change without prior notice and any obligation on the part of the manufacturer.  
© 2021 SMC Corporation All Rights Reserved