



# Operation Manual

PRODUCT NAME

Digital Flow Switch  
(Integrated display type)

MODEL / Series / Product Number

*PFM7##*

**SMC Corporation**

## Table of Contents

Safety Instructions	2
Model Indication and How to Order	10
Summary of Product parts	13
Mounting and Installation	14
Installation	14
Piping	16
Wiring	17
Flow Setting	20
Function Setting	22
Default settings	22
F0 Unit selection function	23
F1 Setting of OUT1	24
F2 Setting of OUT2	27
F3 Operating fluid	28
F4 Reference condition	29
F5 Response time	30
F6 Display mode	31
F7 External input	32
F8 Display resolution	35
F9 Auto-preset	36
F10 Accumulated value hold	38
F11 Analogue output filter	39
F12 Power saving mode	40
F13 Security code	41
F98 Setting of all functions	42
F99 Reset to the default settings	44
Other Settings	45
Maintenance	49
Troubleshooting	50
Error indication	53
Specification	54
Specifications	54
Characteristics data	57
Dimensions	59
Made to Order	73



# Safety Instructions

These safety instructions are intended to prevent hazardous situations and/or equipment damage. These instructions indicate the level of potential hazard with the labels of "Caution", "Warning" or "Danger". They are all important notes for safety and must be followed in addition to International Standards (ISO/IEC)\*1), and other safety regulations.

\*1) ISO 4414: Pneumatic fluid power -- General rules relating to systems.

ISO 4413: Hydraulic fluid power -- General rules relating to systems.

IEC 60204-1: Safety of machinery -- Electrical equipment of machines .(Part 1: General requirements)

ISO 10218: Manipulating industrial robots -Safety.

etc.



## Caution

**Caution** indicates a hazard with a low level of risk which, if not avoided, could result in minor or moderate injury.



## Warning

**Warning** indicates a hazard with a medium level of risk which, if not avoided, could result in death or serious injury.



## Danger

**Danger** indicates a hazard with a high level of risk which, if not avoided, will result in death or serious injury.

## Warning

### 1. The compatibility of the product is the responsibility of the person who designs the equipment or decides its specifications.

Since the product specified here is used under various operating conditions, its compatibility with specific equipment must be decided by the person who designs the equipment or decides its specifications based on necessary analysis and test results.

The expected performance and safety assurance of the equipment will be the responsibility of the person who has determined its compatibility with the product.

This person should also continuously review all specifications of the product referring to its latest catalog information, with a view to giving due consideration to any possibility of equipment failure when configuring the equipment.

### 2. Only personnel with appropriate training should operate machinery and equipment.

The product specified here may become unsafe if handled incorrectly.

The assembly, operation and maintenance of machines or equipment including our products must be performed by an operator who is appropriately trained and experienced.

### 3. Do not service or attempt to remove product and machinery/equipment until safety is confirmed.

1. The inspection and maintenance of machinery/equipment should only be performed after measures to prevent falling or runaway of the driven objects have been confirmed.

2. When the product is to be removed, confirm that the safety measures as mentioned above are implemented and the power from any appropriate source is cut, and read and understand the specific product precautions of all relevant products carefully.

3. Before machinery/equipment is restarted, take measures to prevent unexpected operation and malfunction.

### 4. Contact SMC beforehand and take special consideration of safety measures if the product is to be used in any of the following conditions.

1. Conditions and environments outside of the given specifications, or use outdoors or in a place exposed to direct sunlight.

2. Installation on equipment in conjunction with atomic energy, railways, air navigation, space, shipping, vehicles, military, medical treatment, combustion and recreation, or equipment in contact with food and beverages, emergency stop circuits, clutch and brake circuits in press applications, safety equipment or other applications unsuitable for the standard specifications described in the product catalog.

3. An application which could have negative effects on people, property, or animals requiring special safety analysis.

4. Use in an interlock circuit, which requires the provision of double interlock for possible failure by using a mechanical protective function, and periodical checks to confirm proper operation.



# Safety Instructions

## Caution

### **1. The product is provided for use in manufacturing industries.**

The product herein described is basically provided for peaceful use in manufacturing industries. If considering using the product in other industries, consult SMC beforehand and exchange specifications or a contract if necessary.  
If anything is unclear, contact your nearest sales branch.

## Limited warranty and Disclaimer/Compliance Requirements

The product used is subject to the following "Limited warranty and Disclaimer" and "Compliance Requirements".

Read and accept them before using the product.

### Limited warranty and Disclaimer

#### **1. The warranty period of the product is 1 year in service or 1.5 years after the product is delivered, whichever is first.\*2)**

Also, the product may have specified durability, running distance or replacement parts. Please consult your nearest sales branch.

#### **2. For any failure or damage reported within the warranty period which is clearly our responsibility, a replacement product or necessary parts will be provided.**

This limited warranty applies only to our product independently, and not to any other damage incurred due to the failure of the product.

#### **3. Prior to using SMC products, please read and understand the warranty terms and disclaimers noted in the specified catalog for the particular products.**

##### **\*2) Vacuum pads are excluded from this 1 year warranty.**

A vacuum pad is a consumable part, so it is warranted for a year after it is delivered.

Also, even within the warranty period, the wear of a product due to the use of the vacuum pad or failure due to the deterioration of rubber material are not covered by the limited warranty.

### Compliance Requirements

#### **1. The use of SMC products with production equipment for the manufacture of weapons of mass destruction (WMD) or any other weapon is strictly prohibited.**

#### **2. The exports of SMC products or technology from one country to another are governed by the relevant security laws and regulation of the countries involved in the transaction. Prior to the shipment of a SMC product to another country, assure that all local rules governing that export are known and followed.**

## Caution

### **SMC products are not intended for use as instruments for legal metrology.**

Products that SMC manufactures or sells are not measurement instruments that are qualified by pattern approval tests relating to the measurement laws of each country.

Therefore, SMC products cannot be used for business or certification ordained by the measurement laws of each country.

## Operator

- ◆ This operation manual is intended for those who have knowledge of machinery using pneumatic equipment, and have sufficient knowledge of assembly, operation and maintenance of such equipment. Only those persons are allowed to perform assembly, operation and maintenance.
- ◆ Read and understand this operation manual carefully before assembling, operating or providing maintenance to the product.

### ■ Safety Instructions

#### **Warning**

- Do not disassemble, modify (including changing the printed circuit board) or repair.  
An injury or failure can result.
- Do not operate the product outside of the specifications.  
Do not use for flammable or harmful fluids.  
Fire, malfunction, or damage to the product can result.  
Verify the specifications before use.
- Do not operate in an atmosphere containing flammable, explosive or corrosive gas.  
Fire or an explosion can result.  
This product is not designed to be explosion proof.
- Do not use the product for flammable fluid.  
A fire or explosion can result.  
Only dry air, N<sub>2</sub>, CO<sub>2</sub> and Ar are applicable.
- Do not use the product in a place where static electricity is a problem.  
Otherwise it can cause failure or malfunction of the system.
- If using the product in an interlocking circuit:
  - Provide a double interlocking system, for example a mechanical system
  - Check the product regularly for proper operationOtherwise malfunction can result, causing an accident.
- The following instructions must be followed during maintenance :
  - Turn off the power supply
  - Stop the air supply, exhaust the residual pressure and verify that the air is released before performing maintenance workOtherwise an injury can result.

## Caution

- Do not touch the terminals and connectors while the power is on.  
Otherwise electric shock, malfunction or damage to the product can result.
- After maintenance is complete, perform appropriate functional inspections and leak tests.  
Stop operation if the equipment does not function properly or there is a leakage of fluid.  
When leakage occurs from parts other than the piping, the product might be faulty.  
Disconnect the power supply and stop the fluid supply.  
Do not apply fluid under leaking conditions.  
Safety cannot be assured in the case of unexpected malfunction.

### ■ NOTE

- Follow the instructions given below when designing, selecting and handling the product.
  - The instructions on design and selection (installation, wiring, environment, adjustment, operation, maintenance, etc.) described below must also be followed.
  - \* Product specifications
    - The direct current power supply used should be UL approved as follows.  
Circuit (Class 2) of maximum 30 Vrms (42.4 V peak) or less, with UL1310 Class 2 power supply unit or UL1585 Class 2 transformer.
    - The product is a UL approved product only if it has a  mark on the body.
    - Use the specified voltage.  
Otherwise failure or malfunction can result.  
Insufficient supply voltage may not drive a load due to a voltage drop inside the product.  
Verify the operating voltage of the load before use.
    - Do not exceed the specified maximum allowable load.  
Otherwise it can cause damage or shorten the lifetime of the product.
    - Data stored by the product is not deleted, even if the power supply is cut off.  
(Writing time: 1000000 cycles, Data duration: 20 years after power off.)
    - Applicable operating fluid depends on the product.  
Check the details of the specifications before using.
    - Before designing piping confirm the pressure loss at the sensor from the pressure loss graph.  
Confirm pressure loss of the sensor from the characteristics data.
    - For the details of compressed air quality, refer to ISO 8573-1, 1.1.2 to 1.6.2.
    - Use the specified measurement flow rate and operating pressure.  
Otherwise it can cause damage to the product or inability to measure correctly.
    - Reserve a space for maintenance.  
Allow sufficient space for maintenance when designing the system.

●Product handling

\*Installation

- Tighten to the specified tightening torque.

If the tightening torque is exceeded the mounting screws and brackets may be damaged.

If the tightening torque is insufficient, the product may be displaced and the mounting screws may come loose (Refer to page 14 "Mounting and Installation".)

- Do not apply excessive stress to the product when it is mounted with a panel mount.

Otherwise damage to the product and disconnection from the panel can result.

- Ensure that the FG terminal is connected to ground when using a commercially available switch-mode power supply.

- Do not drop, hit or apply excessive shock to the product.

Otherwise damage to the internal parts can result, causing malfunction.

- Do not pull the lead wire forcefully, or lift the product by the lead wire. (Tensile force 49N or less)

Hold the product body when handling, to prevent damage, failure or malfunction

- For piping of the product, hold the piping with a spanner on the metal part of the product (Piping attachment).

Holding other parts with a spanner leads to may damage the product.

- Any dust left in the piping should be flushed out by air blow before connecting the piping to the product.

Otherwise damage or malfunction can result.

- Refer to the flow direction of the fluid indicated on the product label for installation and piping.

Retention of air can cause inability to measure accurately.

- Do not mount the body with the bottom facing upwards.

Retention of air can cause inability to measure accurately.

- Do not insert metal wires or other foreign matter into the piping port.

This can damage the sensor causing failure or malfunction.

- Never mount a product in a location that will be used as a foothold.

The product may be damaged if excessive force is applied by stepping or climbing onto it.

- If there is a risk of foreign matter entering the fluid, install and pipe a filter or the mist separator at the inlet to avoid failure and malfunction.

Otherwise damage or malfunction can result.

And it can cause inability to measure accurately.

Refer to the figure below for the recommended pneumatic circuit.

Recommended pneumatic circuit example

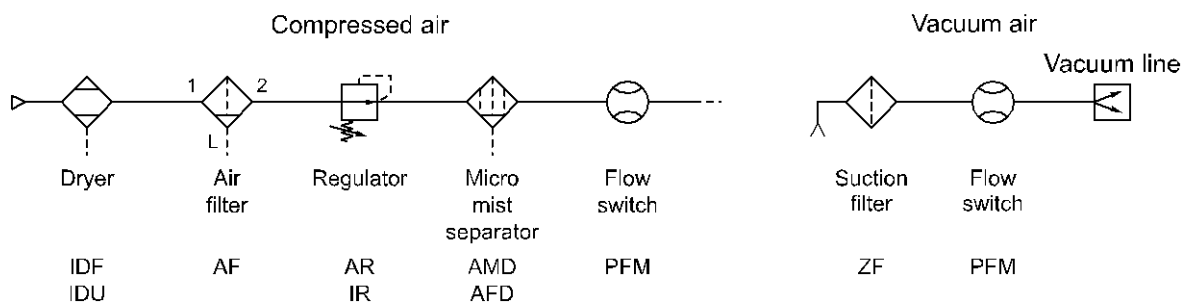

#### \*Wiring

- Do not pull the lead wires.

In particular, never lift a product equipped with fitting and piping by holding the lead wires.

Otherwise damage to the internal parts can result, causing malfunction or disconnection of the connector.

- Avoid repeatedly bending or stretching the lead wire, or placing heavy loads on it

Repeated bending stress or tensile stress can cause damage to the sheath, or breakage of the wires.

If the lead wire can move, fix it near the body of the product.

The recommended bend radius of the lead wire is 6 times the outside diameter of the sheath, or 33 times the outside diameter of the wire insulation material, whichever is larger.

Replace any damaged lead wire with a new one.

- Wire correctly.

Incorrect wiring can damage the product.

- Do not perform wiring while the power is on.

Otherwise damage to the internal parts can result, causing malfunction.

- Do not route wires and cables together with power or high voltage cables.

Otherwise the product can malfunction due to interference or noise and surge voltage from power and high voltage cables.

- Confirm proper insulation of wiring.

Poor insulation (interference from another circuit, poor insulation between terminals, etc.) can lead to excess voltage or current being applied to the product, causing damage.

- Keep wiring as short as possible to prevent interference from electromagnetic noise and surge voltage.

Do not use a cable longer than 30 m.

Wire the DC (-) line (blue) as close as possible to the power supply.

- When analogue output is used, install a noise filter (line noise filter, ferrite element, etc.) between the switch-mode power supply and this product.



#### \*Environment

- Do not use the product in area that is exposed to corrosive gases, chemicals, sea water, water or steam.  
Otherwise failure or malfunction can result.
- Do not use in a place where the product could be splashed by oil or chemicals.  
If the product is to be used in an environment containing oils or chemicals such as coolant or cleaning solvent, even for a short time, it may be adversely affected (damage, malfunction, or hardening of the lead wires)
- Do not use in an area where electrical surges are generated.  
If there is equipment generates large electrical surges (solenoid type lifter, high frequency induction furnace, motor, etc.) close to the product, damage or failure of the internal circuit may occur. Take measures against the surge sources, and prevent the wires from coming into close contact.
- Do not use a load which generates a surge voltage.  
When a surge-generating load such as a relay or solenoid is driven directly, use a product with a built-in surge absorbing element.
- The product is CE/UKCA marked, but not immune to lightning strikes. Take measures against lightning strikes in the system.
- Do not use the product in areas that are exposed to vibration or impact.  
Otherwise failure or malfunction can result.
- Do not use the product in the presence of a magnetic field.  
This may lead to the malfunction of the product.
- Prevent foreign matter such as wire debris from entering the product.  
Otherwise failure or malfunction can result.
- Do not use the product in areas subject to large temperature cycle.  
Heating/cooling cycles other than ordinary changes in temperature can adversely affect the internal structure of the product
- Do not expose the product to direct sunlight.  
If using in a location directly exposed to sunlight, use a suitable protective cover.  
Otherwise failure or malfunction can result.
- Keep within the operating fluid temperature and operation temperatures range.  
The operating fluid temperature and operating temperature range is 0 to 50 °C.  
Operation below the minimum temperature limit may cause damage or operation failure due to frozen moisture in the fluid or air.  
Protection against freezing is necessary.  
An air dryer is recommended for elimination of drainage and water.  
Avoid sudden temperature changes even within the specified temperature range.
- Do not operate close to a heat source, or in a location exposed to radiant heat.  
Otherwise malfunction can result.
- The temperature between products rises when sticking is installed, and there is a possibility to influence the performance of the product.

#### \*Adjustment and Operation

- Connect load before turning on the power.
- Do not short-circuit the load.  
Although an error is displayed when the product load is short circuited, excess current may cause damage to the product.
- Do not press the setting buttons with a sharp pointed object.  
This may damage the setting buttons.
- Supply the power when there is no flow.
- The output is off for 3 seconds after power is supplied.
- Use settings suitable for the operating conditions.  
Incorrect settings can cause operational failure.  
(Refer to page 20 " Flow setting".)
- During the initial setting and any subsequent flow rate setting, the product will switch the output according to the existing settings until the changes are complete.  
Confirm the output has no adverse effect on machinery and equipment before setting.  
Stop the control system before setting if necessary.
- Do not touch the LED during operation.  
The display can vary due to static electricity.

#### \*Maintenance

- Perform regular maintenance and inspections.  
There is a risk of unexpected malfunction of components due to the malfunction of equipment and machinery.
- Turn off the power supply, stop the supplied air, exhaust the residual pressure and verify the release of air before performing maintenance.  
There is a risk of unexpected malfunction.
- Perform drainage regularly.  
If condensate enters the outside, it can cause operating failure of pneumatic equipment.
- Do not use solvents such as benzene, thinner etc. to clean the product.  
They could damage the surface of the body and erase the markings on the body.  
Use a soft cloth to remove stains.  
For heavy stains, use a cloth lightly dampened with diluted neutral detergent, then wipe up any residue with a dry cloth.

#### \*Other

- If there is a restrictor fitted, vibration may cause the flow adjustment valve to rotate and change the flow rate.
- Accuracy may vary by 2 to 3% if the customer removes or replaces the piping port.

# Model Indication and How to Order

PFM 7 □ □ - □ □ - □ □ - □ □ - □ □ - □ □

Integrated display type

Rated flow range

Symbol	Content
10	0.2 to 10 (5) L/min
25	0.5 to 25 (12.5) L/min
50	1 to 50 (25) L/min
11	2 to 100 (50) L/min

\*1: Value in ( ) is the flow rate when CO<sub>2</sub> is used.

Flow adjustment valve

Symbol	Content
Nil	without flow adjustment valve
S	with flow adjustment valve

Made to order  
(Refer to page 12.)

Option 2  
(Refer to page 11.)

Option 1  
(Refer to page 11.)

Calibration certificate

Symbol	Content
Nil	without calibration certificate
A	with calibration certificate *2

\*2: Certificate in both Japanese and English.

Operation manual

Symbol	Content
Nil	with operation manual (Japanese and English)
N	without operation manual

Unit specification

Symbol	Content
Nil	Unit selection function *3
M	SI unit only *4

\*3: Since the unit for Japan is fixed to SI due to new measurement law, this option is for overseas.

\*4: Fixed unit Instantaneous flow: L/min, Accumulated flow: L

Output specification

Symbol	Content
A	NPN (2 outputs)
B	PNP (2 outputs)
C	NPN (1 output) + Analogue (1 to 5 V)
D	NPN (1 output) + Analogue (4 to 20 mA)
E	PNP (1 output) + Analogue (1 to 5 V)
F	PNP (1 output) + Analogue (4 to 20 mA)
G	NPN (1 output) + External input *5
H	PNP (1 output) + External input *5

\*5: Accumulated flow external reset or auto-shift or auto-shift zero are selectable.

Piping direction

Symbol	Content
Nil	Straight
L	Bottom entry

\*6: Combination of piping direction of IN side and OUT side are specified to order.

Thread type (Port size)

Symbol	Content	Flow range			
		10	25	50	11
01	Rc1/8	●	●	●	-
02	Rc1/4	-	-	-	●
N01	NPT1/8	●	●	●	-
N02	NPT1/4	-	-	-	●
F01	G1/8	●	●	●	-
F02	G1/4	-	-	-	●
C4	φ 4 (5/32") One-touch fitting	●	-	-	-
C6	φ 6 One-touch fitting	●	●	●	●
C8	φ 8 (5/16") One-touch fitting	-	●	●	●
N7	φ 1/4 One-touch fitting	-	●	●	●

### Option1

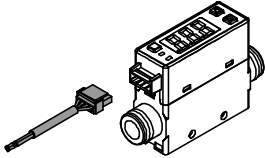
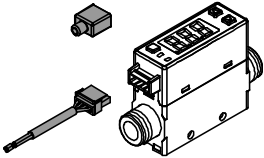
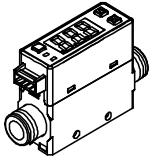
Nil	W	Z
<p>with lead wire and connector (2 m)</p> 	<p>with lead wire and connector (2 m) + Connector cover (silicone rubber)</p> 	<p>without lead wire</p> 

### Option2

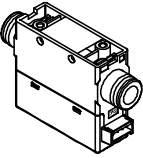
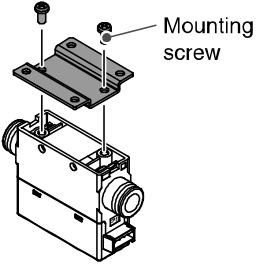
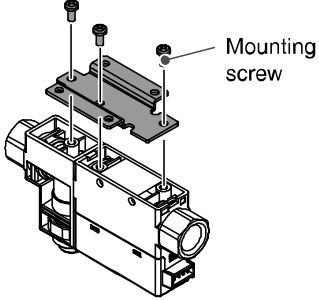
Nil	R	S
<p>without bracket</p> 	<p>with bracket (without flow adjustment valve)</p>  <p>Mounting screw</p>	<p>with bracket (with flow adjustment valve)</p>  <p>Mounting screw</p> <p>Not applicable to bottom entry type</p>

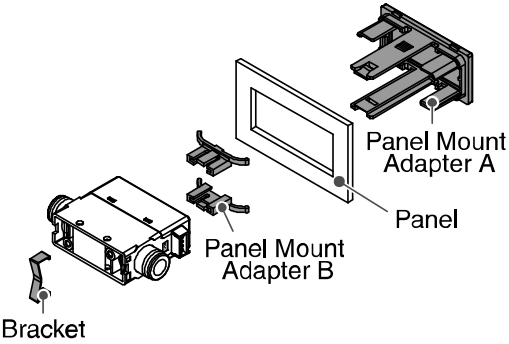
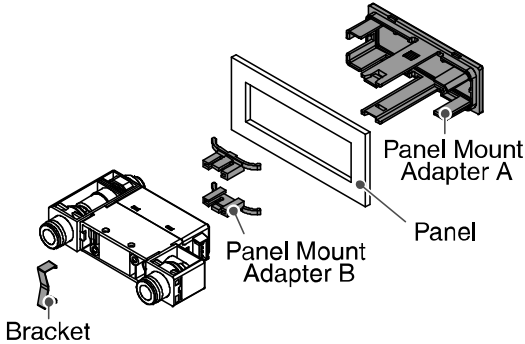
T	V
<p>with panel mount adapter (without flow adjustment valve)</p>  <p>Bracket</p> <p>Panel Mount Adapter B</p> <p>Panel</p> <p>Panel Mount Adapter A</p>	<p>with panel mount adapter (with flow adjustment valve)</p>  <p>Bracket</p> <p>Panel Mount Adapter B</p> <p>Panel</p> <p>Panel Mount Adapter A</p>

\*: Each accessory is not assembled with the product, but shipped together.

## Made to Order

Symbol	Content	Page
X693	Special combination of piping directions IN side: Straight OUT side: Bottom entry	Page 73
X694	Special combination of piping directions IN side: Bottom entry OUT side: Straight	Page 73
X731	For Argon (Ar) and carbon dioxide (CO <sub>2</sub> ) mixtures. Mixture ratio (Ar : CO <sub>2</sub> ) 92:8, 90:10, 80:20, 70:30, 60:40	Page 75

## Accessories/Part number

If an accessory is required separately, order using the following part numbers.

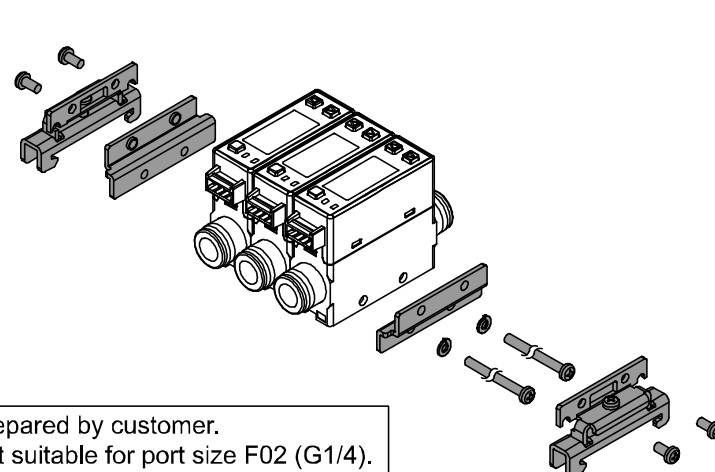
Part number	Description	Remarks										
ZS-33-D	Lead wire and connector	Length: 2 m										
ZS-33-F	Connector cover (silicone rubber) 											
ZS-33-J	Panel mount adapter (without flow adjustment valve)											
ZS-33-JS	Panel mount adapter (with flow adjustment valve)											
ZS-33-M	Bracket (without flow adjustment valve)	Mounting screw 2 pcs.										
ZS-33-MS	Bracket (with flow adjustment valve)	Mounting screw 3 pcs.										
ZS-33-R□	<p>DIN rail mounting parts</p> <p>ZS-33-R□</p> <p>Number of stations</p> <table border="1"> <tbody> <tr> <td>1</td> <td>1 station</td> </tr> <tr> <td>2</td> <td>2 stations</td> </tr> <tr> <td>3</td> <td>3 stations</td> </tr> <tr> <td>4</td> <td>4 stations</td> </tr> <tr> <td>5</td> <td>5 stations</td> </tr> </tbody> </table>  <div style="border: 1px solid black; padding: 5px; margin-top: 10px;"> <ul style="list-style-type: none"> <li>· DIN rail is prepared by customer.</li> <li>· DIN rail is not suitable for port size F02 (G1/4).</li> </ul> </div>	1	1 station	2	2 stations	3	3 stations	4	4 stations	5	5 stations	
1	1 station											
2	2 stations											
3	3 stations											
4	4 stations											
5	5 stations											

## Summary of Product parts

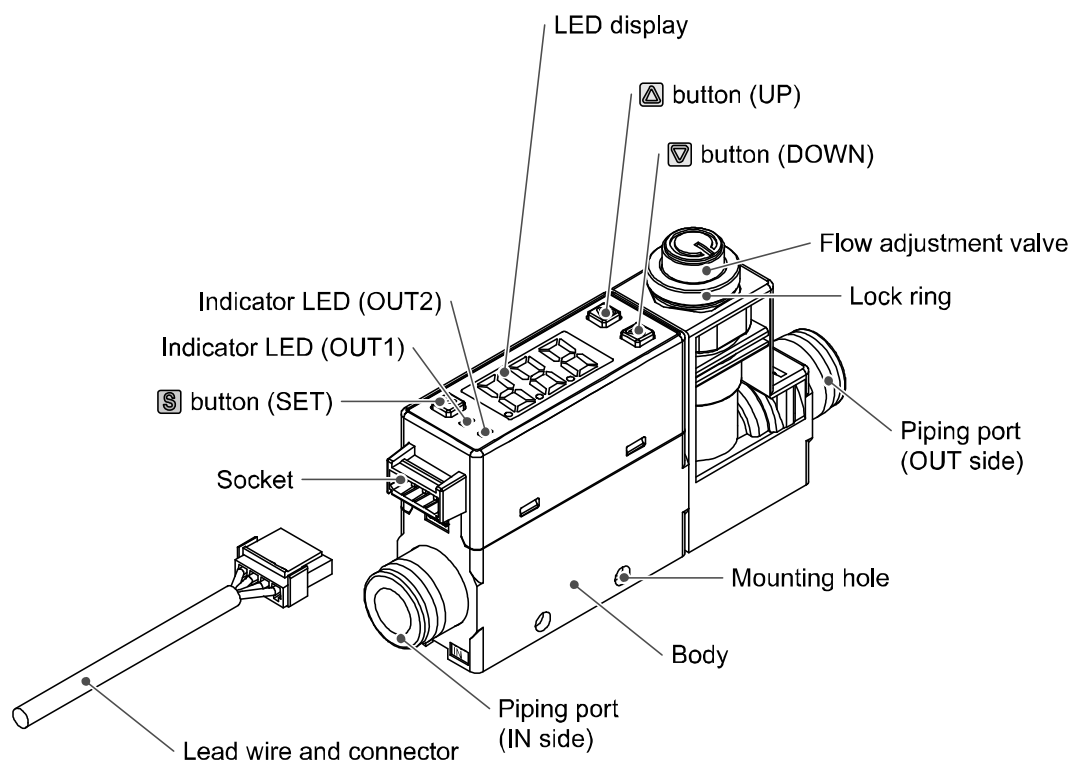

Item	Description
Indicator LED (OUT1)	Indicates the output status of OUT1. LED is ON (Green) when OUT1 is ON. When the accumulated pulse output mode is selected, the indicator LED will turn OFF.
Indicator LED (OUT2)	Indicates the output status of OUT2. LED is ON (Red) when OUT2 is ON. When the accumulated pulse output mode is selected, the indicator LED will turn OFF.
Ⓢ button ( SET )	Press this button to change to another mode and to set a value.
Socket	Socket for electrical connections.
Piping port	Connected to the fluid inlet at IN side and to the fluid outlet at OUT side.
LED display	Displays the flow value, setting mode, and error indication. Four display modes can be selected: display always in red or green, or display changing from green to red, or red to green, according to the output status (OUT1).
▲ button (UP)	Selects the mode or increases the ON/OFF set value. Press this button to change to the peak display mode.
▼ button (DOWN)	Selects the mode or decreases the ON/OFF set value. Press this button to change to the bottom display mode.
Flow adjustment valve *	Orifice mechanism to adjust the flow.
Lock ring *	Used to lock the flow adjustment valve.
Mounting hole	Used to mount the product on a DIN rail or directly to a panel.
Body	The body of the product.
Lead wire and connector	Lead wire to supply power and transmit output signals.

\*: The table shows the specifications when a flow adjusting valve is included.

## Mounting and Installation

### ■ Installation

- Refer to the flow direction of the fluid indication on the product label for installation and piping.

#### Panel mounting

- Insert Panel Mount Adapter B (supplied as an accessory) into Section A of Panel Mount Adapter A. Push Panel Mount Adapter B from behind until the display is fixed onto the panel.  
The pin of bracket engages the notched part of panel adapter A section C to fix the display.
- The switch can be mounted on a panel with a thickness of 1 to 3.2 mm.
- Refer to the dimension drawing (page 71) for panel cut-out dimensions.

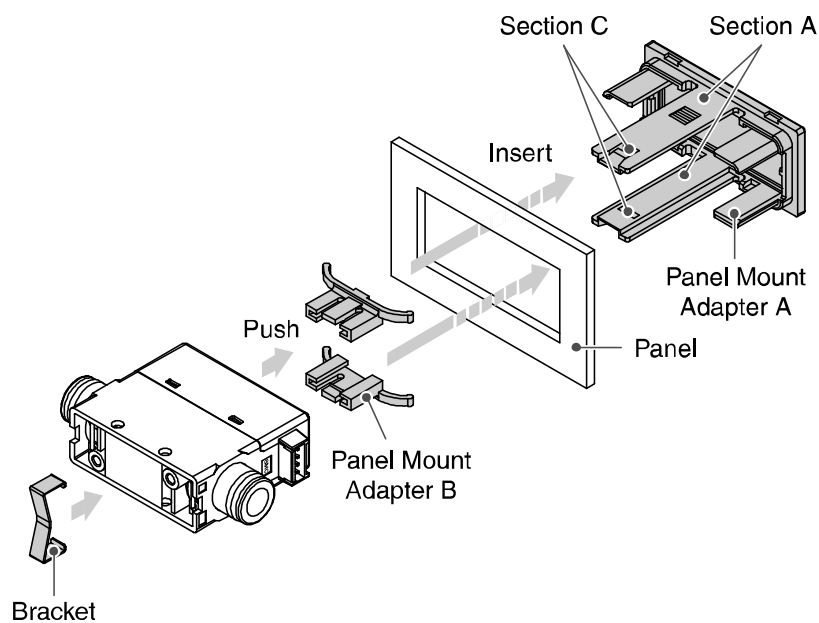

## Bracket mounting

- Mount the bracket using the mounting screws supplied.
- The required tightening torque is  $0.5 \pm 0.05$  N•m.

Without flow adjustment valve  
(using ZS-33-M)

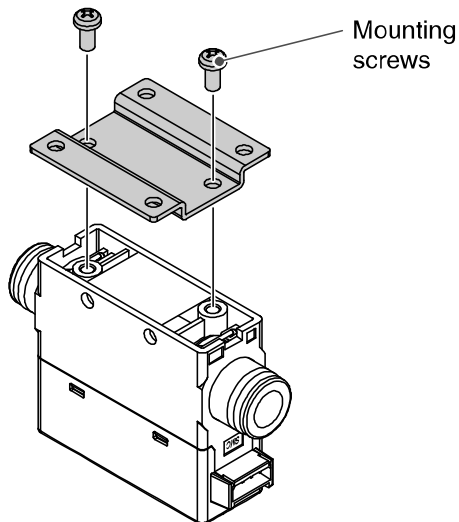

With flow adjustment valve  
(using ZS-33-MS)

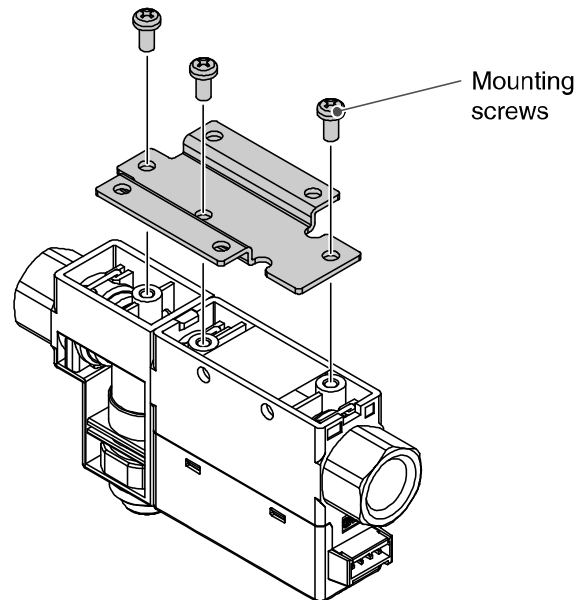

- Install the product (with bracket) using the M3 screws (4 pcs.).
- Bracket thickness is approximately 1.2 mm.
- Refer to the dimension drawing of the bracket (page 71) for mounting hole dimensions.

## DIN rail mounting (using ZS-33-R□)

- Mount the DIN rail mounting parts using DIN rail mounting screws and joint screws supplied.
- The required tightening torque of the DIN rail mounting screws and joint screws is  $0.4 \pm 0.05$  N•m.

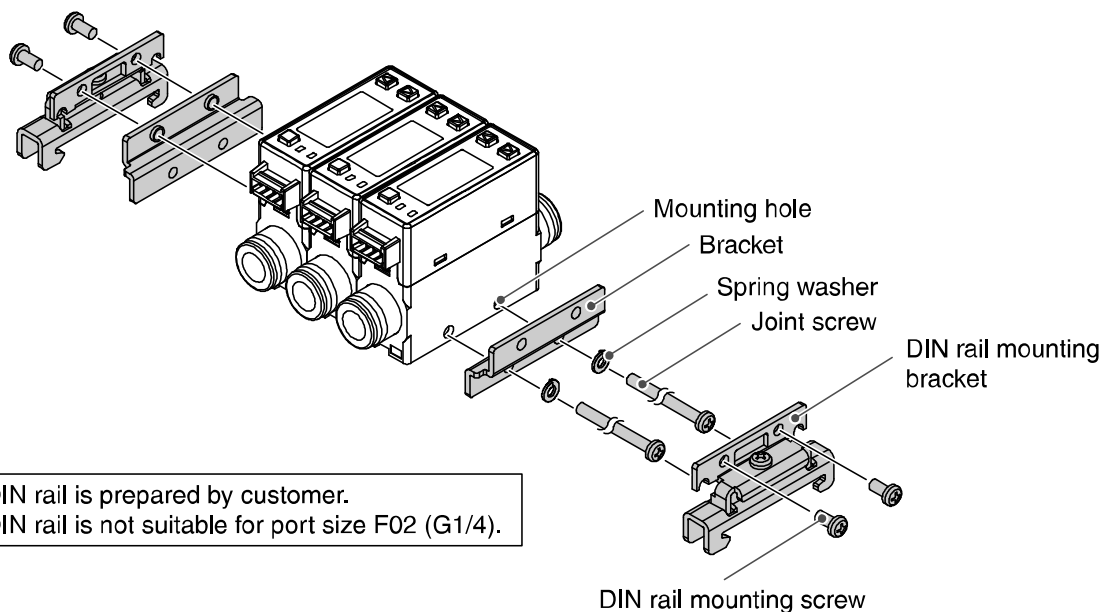



## ■Piping

### For the metal piping attachments

- Ensure that the metal piping attachments are tightened to the required torque (refer to the table below).
- If the tightening torque is exceeded, the product can be broken. If the tightening torque is insufficient, the fittings may become loose.
- When connecting piping to the product, a spanner should be used on the metal piping attachment only. Using a spanner on other parts may damage the product.
- Avoid any sealing tape from entering inside the piping.
- Ensure that there is no leakage from loose piping.

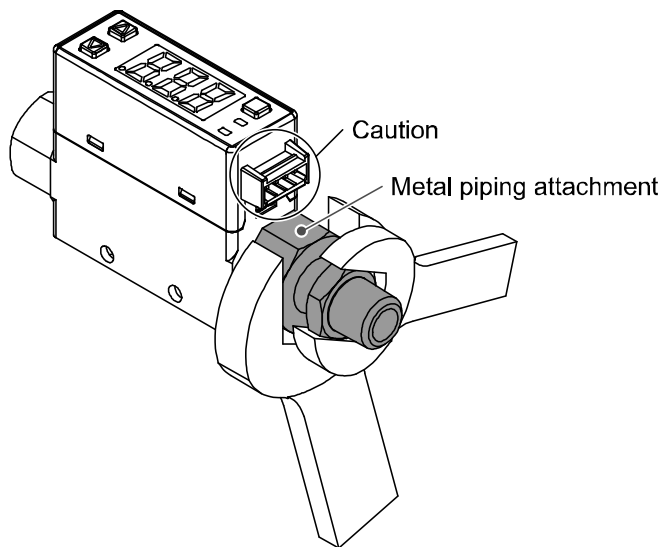

Nominal thread size	Required torque
Rc(NPT)1/8	7 to 9 N•m
Rc(NPT)1/4	12 to 14 N•m

Nominal thread size	Width across flats of attachment
Rc(NPT)1/8 Rc(NPT)1/4 G1/8	17 mm
G1/4	21 mm

### For one-touch fittings

- Insert the tube until it bottoms out, to ensure it cannot be pulled out.
- Insertion with excessive force can cause damage.
- Ensure that there is no leakage after piping.
- Use this product within the specified operating pressure and temperature ranges.
- Proof pressure is 1.0 MPa.

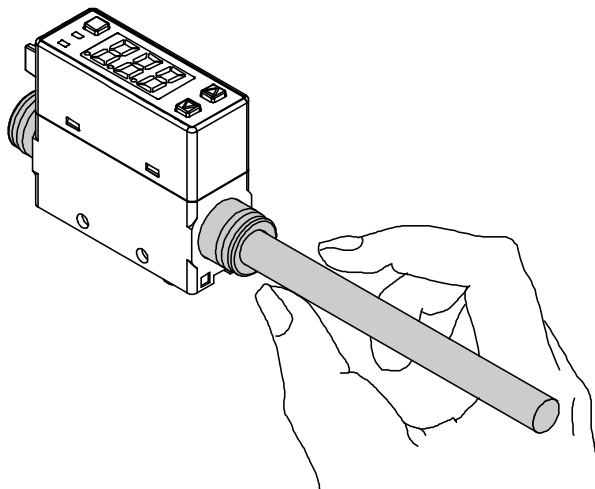

## ■Wiring

### Wiring of connector

- Connections should only be made with the power supply turned off.
- Use separate routes for the product wiring and any power or high voltage wiring. Otherwise, malfunction may result due to noise.
- Ensure that the FG terminal is connected to ground when using a commercially available switch-mode power supply. When a switch-mode power supply is connected to the product, switching noise will be superimposed and the product specification can no longer be met. This can be prevented by inserting a noise filter, such as a line noise filter and ferrite core, between the switch-mode power supply and the product, or by using a series power supply instead of a switch-mode power supply.

### Connecting/Disconnecting

- When mounting the connector, insert it straight into the socket, holding the lever and connector body, and push the connector until the lever hooks into the housing, and locks.
- When removing the connector, press down the lever to release the hook from the housing and pull the connector straight out.

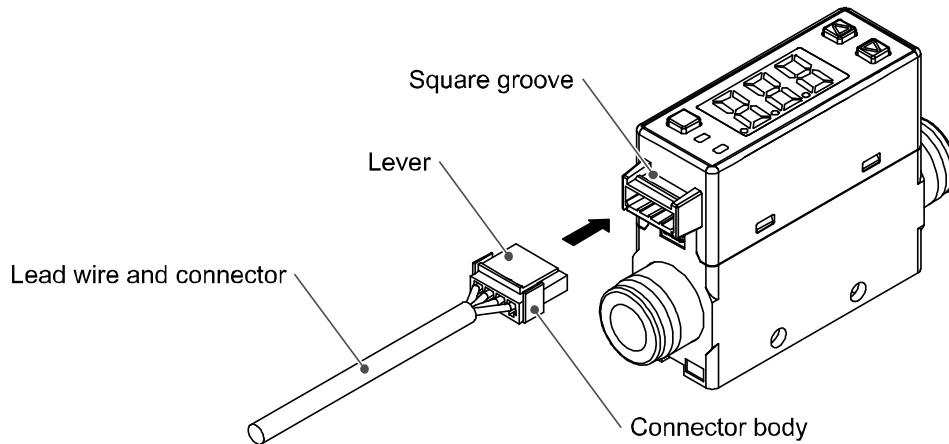

### Connector pin numbers (on the lead wire)

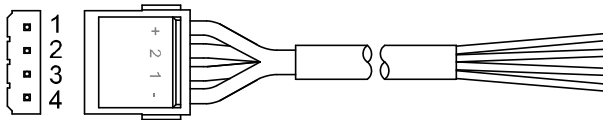

Connector pin numbers	Wire colour	Description
1	Brown	DC(+)
2	White	OUT2/Analogue output/External input
3	Black	OUT1
4	Blue	DC(-)

## Internal circuit and wiring example

NPN (2 outputs) type

PFM7□□-□□-**A**-□□□

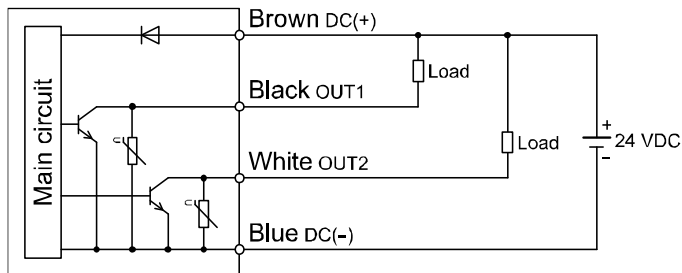

Max. 28 V, 80 mA

Internal voltage drop: 1 V or less

NPN (1 output) + Analogue (1 to 5 V) output type

PFM7□□-□□-**C**-□□□

NPN (1 output) + Analogue (4 to 20 mA) output type

PFM7□□-□□-**D**-□□□

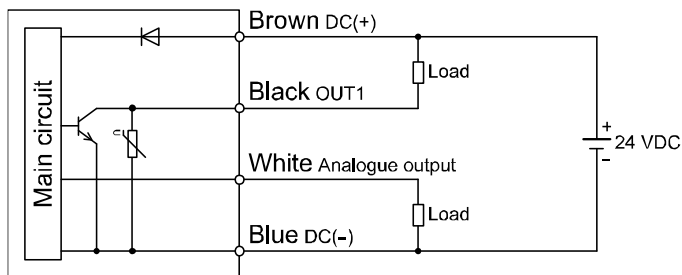

Max. 28 V, 80 mA

Internal voltage drop: 1 V or less

C: Analogue output: 1 to 5 V

Output impedance: 1 k $\Omega$

D: Analogue output: 4 to 20 mA

Max. load impedance: 600  $\Omega$

Min. load impedance: 50  $\Omega$

NPN (1 output) + External input type

PFM7□□-□□-**G**-□□□

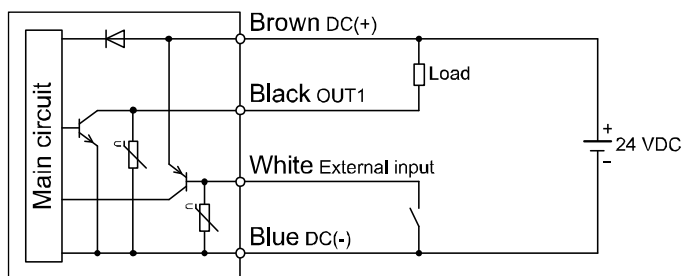

Max. 28 V, 80 mA

Internal voltage drop: 1 V or less

External input: No voltage input (reed switch or solid state), 30 ms or more

PNP (2 outputs) type

PFM7□□-□□-**B**-□□□

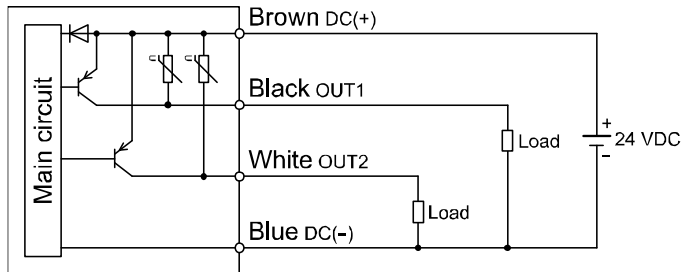

Max. 80 mA

Internal voltage drop: 1.5 V or less

PNP (1 output) + Analogue (1 to 5 V) output type

PFM7□□-□□-**E**-□□□

PNP (1 output) + Analogue (4 to 20 mA) output type

PFM7□□-□□-**F**-□□□

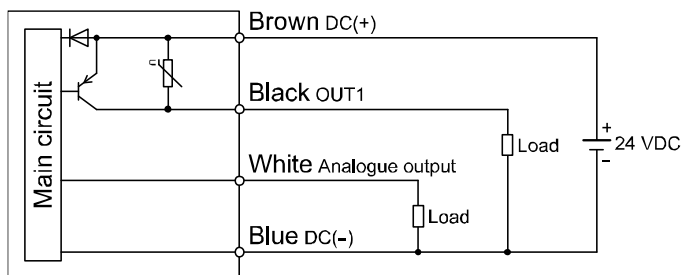

Max. 80mA

Internal voltage drop: 1.5 V or less

E: Analogue output: 1 to 5 V

Output impedance: 1 kΩ

F: Analogue output: 4 to 20 mA

Max. load impedance: 600 Ω

Min. load impedance: 50 Ω

PNP (1 output) + External input type

PFM7□□-□□-**H**-□□□

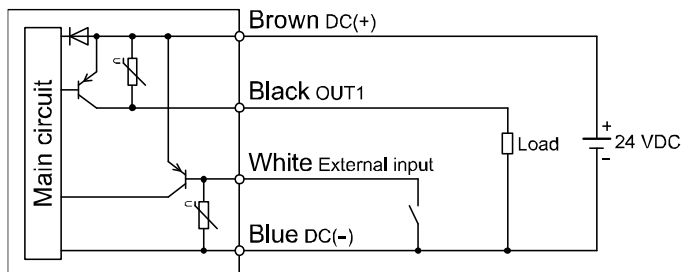

Max. 80 mA

Internal voltage drop: 1.5 V or less

External input: No voltage input (reed switch or solid state), 30 ms or more

# Flow Setting

## Measurement mode

The mode in which the flow is detected and displayed, and the switch function is operating. This is the basic operating mode; other modes should be selected for set-point and other Function Setting changes.

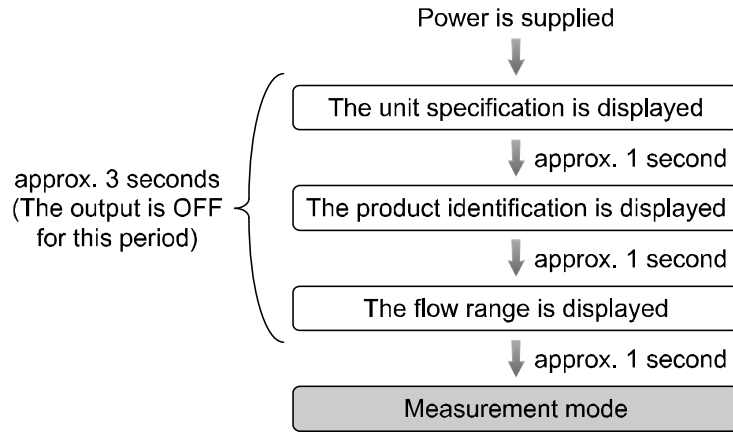

## Switch operation

When the flow exceeds the set value, the switch will turn ON. When the flow falls below the set value by the amount of hysteresis or more, the switch will turn OFF. If this condition, shown to the right, is acceptable, then keep these settings.

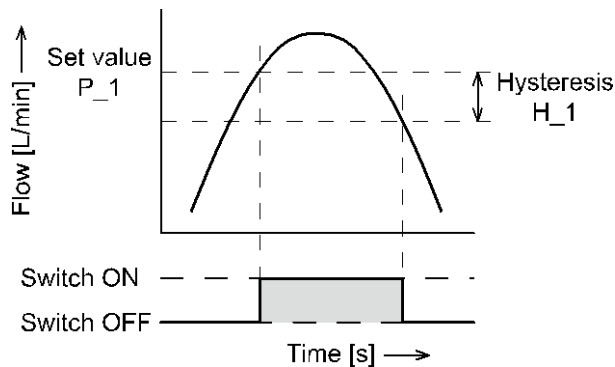

<Operation> \*: The Product outputs will continue operating during setting.

1. Press the **[S]** button once in measurement mode.



[P\_1] or [n\_1] and the set value are displayed in turn.



2. Press the **[▲]** or **[▼]** button to change the set value.

The **[▲]** button is to increase and the **[▼]** button is to decrease the set value.

• Press the **[▲]** button once to increase by one digit, or press it continuously to keep increasing the set value.



• Press the **[▼]** button once to decrease by one digit, or press it continuously to keep decreasing the set value.

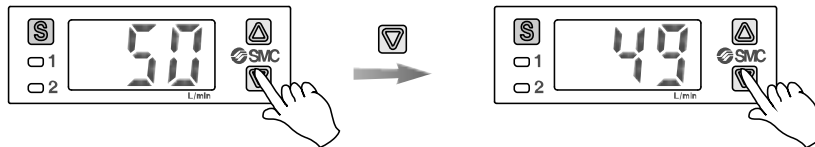

3. Press the **[S]** button to complete the setting of OUT1.

For models with 2 outputs, [P\_2] or [n\_2] will be displayed. Set as above.

#### Zero clear of display

The display is reset to zero when **[▲]** and **[▼]** are pressed simultaneously for 1 second (page 45).

For the initial operation, always perform zero clear with no flow applied.

# Function Setting

## Function selection mode

In measurement mode, press the **[S]** button for 2 seconds or longer, to display [F 1].  
(when using a product with unit selection function, [F 0] will be displayed).

The [F□□] indicates the mode for changing each Function Setting.

Press the **[S]** button for 2 seconds or longer in function selection mode to return to measurement mode.

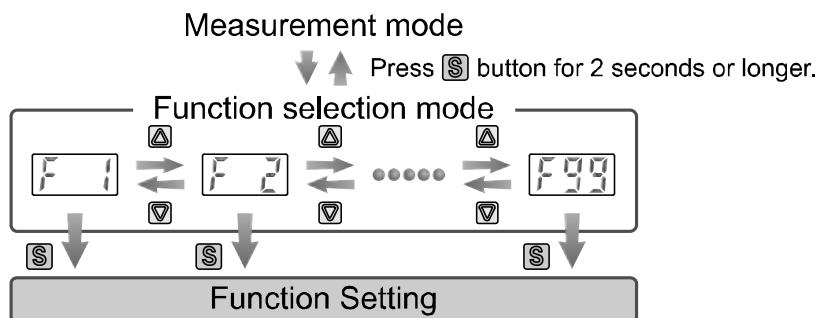

## ■Default settings

Item		Default setting	Page
[F 0]	[Uni] Unit selection function	[ L ] L/min	Page <a href="#">23</a>
[F 1]	[oU1] Output mode (OUT1)	[HYS] Hysteresis mode	Page <a href="#">24</a>
	[1ot] Reversed output (OUT1)	[1_P] Normal output	
	[P_1] Input of set value (OUT1)	[ ] 50% of maximums rated flow PFM710: 5 L/min, PFM725: 12.5 L/min PFM750: 25 L/min, PFM711: 50 L/min	Page <a href="#">25</a>
	[H_1] Setting of Hysteresis (OUT1)	[ ] 3% of maximums rated flow PFM710: 0.3 L/min, PFM725: 0.8 L/min PFM750: 1.5 L/min, PFM711: 3 L/min	
	[CoL] Display colour	[SoG] ON: Green OFF: Red	
[F 2]	[oU2] Output mode (OUT2)	[HYS] Hysteresis mode	Page <a href="#">27</a>
	[2ot] Reversed output (OUT2)	[2_P] Normal output	
	[P_2] Input of set value (OUT2)	[ ] 50% of maximums rated flow PFM710: 5 L/min, PFM725: 12.5 L/min PFM750: 25 L/min, PFM711: 50 L/min	
	[H_2] Setting of Hysteresis (OUT2)	[ ] 3% of maximums rated flow PFM710: 0.3 L/min, PFM725: 0.8 L/min PFM750: 1.5 L/min, PFM711: 3 L/min	
[F 3]	[FLU] Operating fluid	[Air] dry air, N <sub>2</sub>	Page <a href="#">28</a>
[F 4]	[rEF] Reference condition	[Anr] Standard condition	Page <a href="#">29</a>
[F 5]	[eES] Response time	[1.00] 1 second	Page <a href="#">30</a>
[F 6]	[dSP] Display mode	[inS] Instantaneous flow	Page <a href="#">31</a>
[F 7]	[inP] External input	[r_r] Accumulated flow external reset	Page <a href="#">32</a>
[F 8]	[drE] Display resolution	[1E2] 100-split	Page <a href="#">35</a>
[F 9]	[PrS] Auto-preset	[oFF] Manual	Page <a href="#">36</a>
[F10]	[EEP] Accumulated value hold	[oFF] OFF	Page <a href="#">38</a>
[F11]	[AFL] Analogue output filter	[ on ] With filter	Page <a href="#">39</a>
[F12]	[Eco] Power saving mode	[oFF] Unused	Page <a href="#">40</a>
[F13]	[Pin] Security code	[oFF] Unused	Page <a href="#">41</a>
[F98]	[ALL] Setting of all functions	[oFF] Unused	Page <a href="#">42</a>
[F99]	[ini] Reset to the default settings	[oFF] Unused	Page <a href="#">44</a>



## ■ [F 0] Unit selection function

This function is only available for products with the unit selection function.

L/min or CFM (ft<sup>3</sup>/min) x 10<sup>-2</sup> are selectable for the displayed units.

\*: When the products other than unit selection type are used, this function is not displayed.

<Operation>

Press the  or  button in function selection mode to display [F 0].

Press the  button. ↓

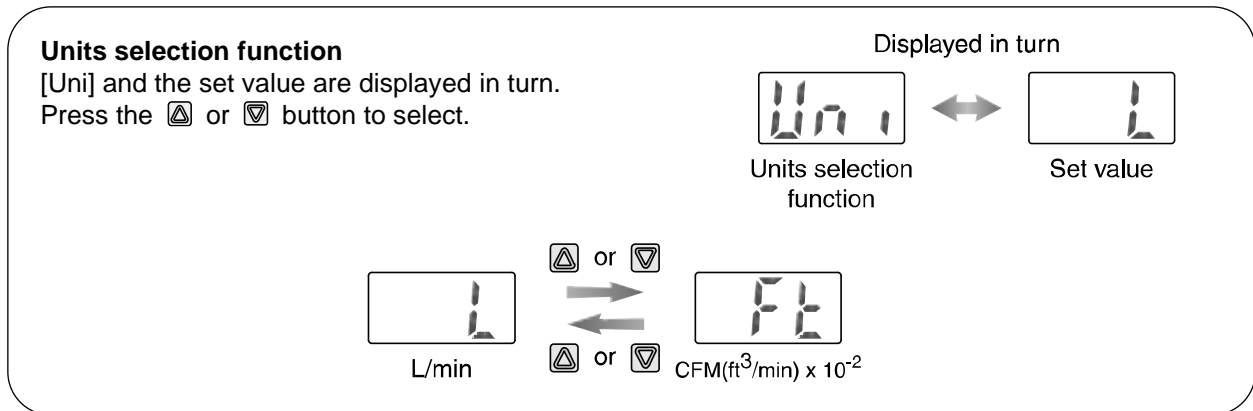

Press the  button. ↓ Return to function selection mode.

Setting of [F 0] Unit selection function completed

Flow specification when [ Ft ] is selected by unit selection function

Model			PFM710	PFM725	PFM750	PFM711
Rated flow range		Dry air, N <sub>2</sub> , Ar	0.8 to 35.3 CFM x 10 <sup>-2</sup>	1.8 to 88.3 CFM x 10 <sup>-2</sup>	4 to 177 CFM x 10 <sup>-2</sup>	8 to 353 CFM x 10 <sup>-2</sup>
		CO <sub>2</sub>	0.8 to 17.6 CFM x 10 <sup>-2</sup>	1.8 to 44.1 CFM x 10 <sup>-2</sup>	4 to 88 CFM x 10 <sup>-2</sup>	8 to 176 CFM x 10 <sup>-2</sup>
Instantaneous flow	Setting/Display flow range	Dry air, N <sub>2</sub> , Ar	0.8 to 37.1 CFM x 10 <sup>-2</sup>	1.8 to 92.7 CFM x 10 <sup>-2</sup>	4 to 186 CFM x 10 <sup>-2</sup>	8 to 371 CFM x 10 <sup>-2</sup>
		CO <sub>2</sub>	0.8 to 18.5 CFM x 10 <sup>-2</sup>	1.8 to 46.3 CFM x 10 <sup>-2</sup>	4 to 93 CFM x 10 <sup>-2</sup>	8 to 185 CFM x 10 <sup>-2</sup>
	Min. setting/display unit		0.1 CFM x 10 <sup>-2</sup>	0.1 CFM x 10 <sup>-2</sup>	1 CFM x 10 <sup>-2</sup>	1 CFM x 10 <sup>-2</sup>
Accumulated flow	Setting/Display flow range		0.0 to 99999.0 ft <sup>3</sup> x 10 <sup>-1</sup>	0.0 to 99999.9 ft <sup>3</sup> x 10 <sup>-1</sup>	0 to 999999 ft <sup>3</sup> x 10 <sup>-1</sup>	0 to 999999 ft <sup>3</sup> x 10 <sup>-1</sup>
	Min. setting/display unit		0.1 ft <sup>3</sup> x 10 <sup>-1</sup>	0.1 ft <sup>3</sup> x 10 <sup>-1</sup>	1 ft <sup>3</sup> x 10 <sup>-1</sup>	1 ft <sup>3</sup> x 10 <sup>-1</sup>
Conversion of accumulated pulse			0.1 ft <sup>3</sup> x 10 <sup>-1</sup> /pulse	1 ft <sup>3</sup> x 10 <sup>-1</sup> /pulse	1 ft <sup>3</sup> x 10 <sup>-1</sup> /pulse	1 ft <sup>3</sup> x 10 <sup>-1</sup> /pulse

\*: Flow rate in the specification is the value at standard condition.

If the display unit standard is changed from standard to normal, use the conversion formula.

Flow rate at standard condition x 0.927 = Flow rate at normal condition



■[F 1] Setting of OUT1

Set output method of OUT1.

<Operation>

Press the or button in function selection mode to display [F 1].

Press the button. ↓

**Select output mode**  
[oU1] and the set value are displayed in turn.  
Press the or button to select.

Displayed in turn

↔   
Output mode                      Set value

Hysteresis mode      Window comparator mode      Accumulated output mode      Accumulated pulse output mode

Press the button. ↓

**Select reversed output**  
[1ot] and the set value are displayed in turn.  
Press the or button to select.

Displayed in turn

↔   
Select reversed output                      Set value

↔   
Normal output                      Reversed output

Press the button. ↓ (continued)

### Input of set values

Set flow based on setting procedure on page 21.

Hysteresis mode: [P\_1]

Window comparator mode: [P1L] [P1H]

Accumulated output mode: [P1.1] [P1.2]. ([P1.1]...Upper 3 digits, [P1.2]...lower 3 digits)

Accumulated pulse output mode: Omitted

\*: For reversed output, P becomes n.

Press the  button. ↓

### Setting of hysteresis

[H\_1] and the set value are displayed in turn.

Press the  or  button to input.

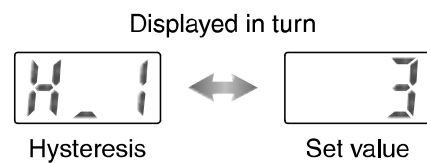

This process is omitted for accumulated output mode, accumulated pulse output mode.

Press the  button. ↓

### Select display colour

[CoL] and the set value are displayed in turn.

Press the  or  button to select.

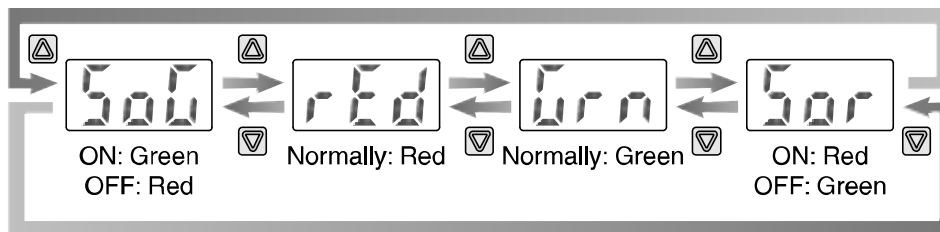
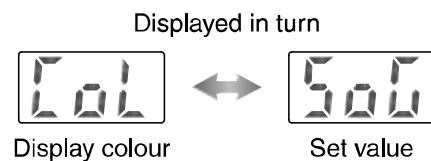

Press the  button. ↓ Return to function selection mode.

[F 1] Setting of OUT1 completed

•List of output modes

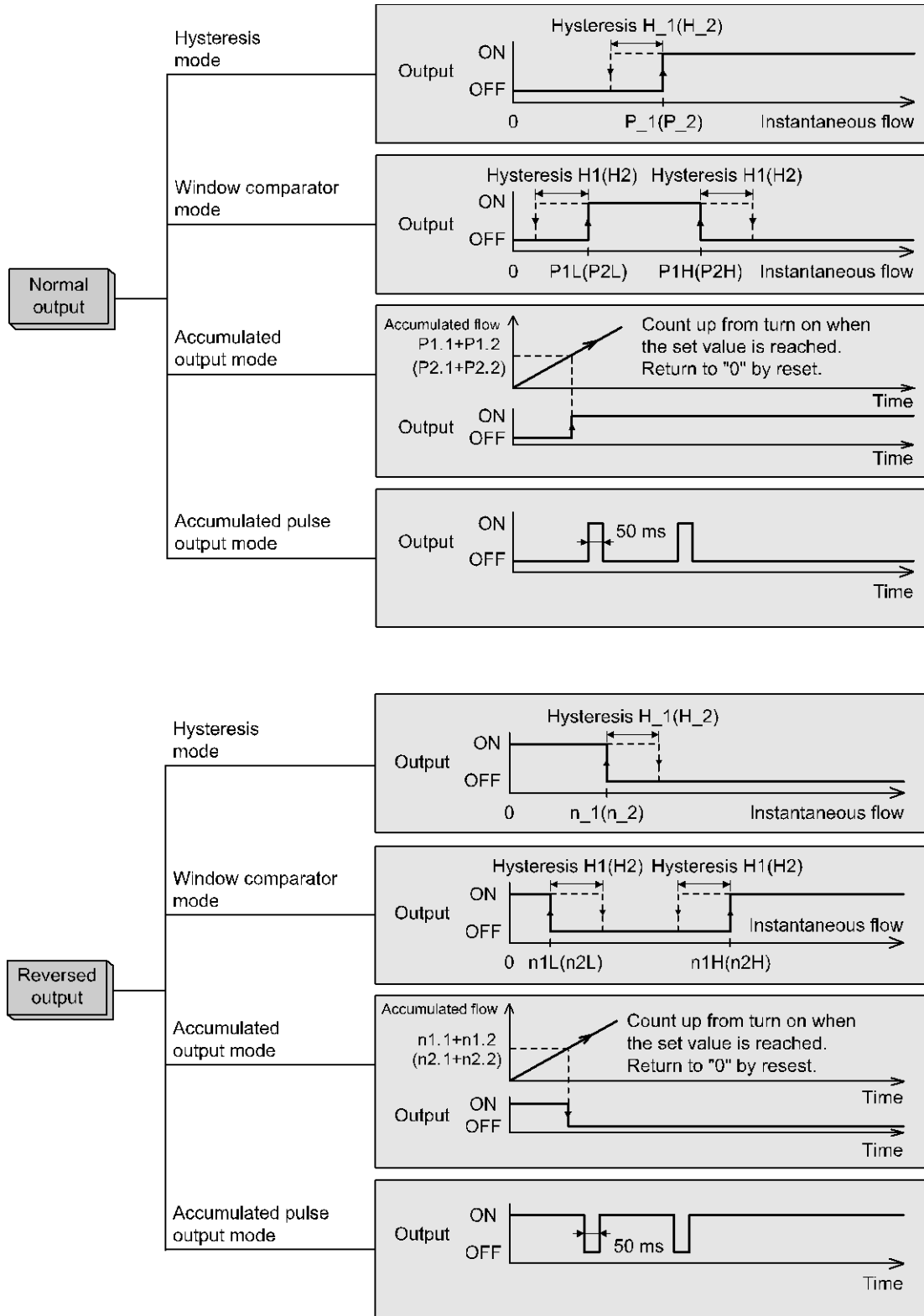



\*: If hysteresis or window comparator mode is selected and there is an unstable flow condition (due to fluid pulsation, for example), unstable output operation can result. In such situations, keep sufficient margin between the set values and confirm that the output operation stabilizes.

## ■[F 2] Setting of OUT2

Set output method of OUT2.

The display colour is linked to the setting of OUT1, and can not be set for OUT2.

<Operation>

Press the  or  button in function selection mode to display [F 2].

Press the  button. 

Set [F 2] based on [F 1] setting of OUT1

\*: When product with analogue output function and external input function are used, this function is not available and [---] is displayed.



### ■[F 3] Operating fluid

In the default setting, the PFM is intended for use with dry air or N<sub>2</sub>.



It is necessary to change the setting when Argon (Ar) or carbon dioxide (CO<sub>2</sub>) are used.

\*: When CO<sub>2</sub> is selected, the upper limit of measurement flow range is half that of other fluids.



<Operation>

Press the  or  button in function selection mode to display [F 3].

Press the  button. ↓

**Select operating fluid**  
[FLU] and the set value are displayed in turn.  
Press the  or  button to select.

Displayed in turn

 ↔   
Operating fluid                      Set value

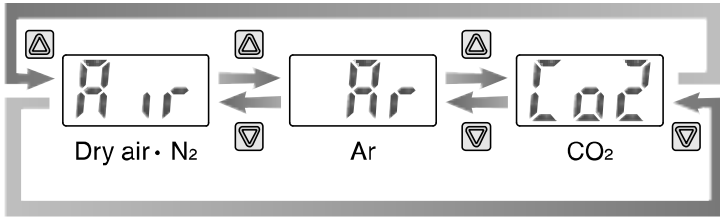

Press the  button. ↓ Return to function selection mode.

[F 3] Selection of operating fluid completed



## ■ [F 4] Reference condition

Standard condition or normal condition can be selected.

Standard condition (ANR) and normal condition (NOR) are defined as follows:

- Standard condition (ANR): 101.3kPa, 20°C, 65%RH.
- Normal condition (NOR): 101.3kPa, 0°C

<Operation>

Press the  or  button in f function selection mode to display [F 4].

Press the  button. ↓

### Select reference condition

[rEF] and the set value are displayed in turn.

Press the  or  button to select.

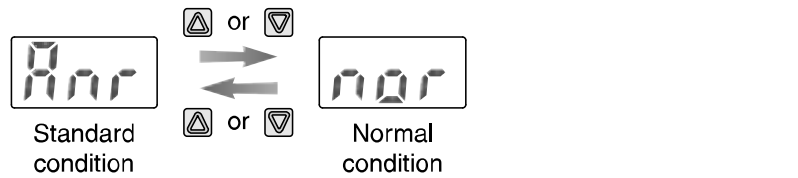

\*: Flow rate in the specification is the value at standard condition.

If the display unit standard is changed from standard to normal, use the conversion formula.

Flow rate at standard condition x 0.927 = Flow rate at normal condition

Press the  button. ↓ Return to function selection mode.



[F 4] Selection of reference condition completed

## ■[F 5] Response time



Select the response time of the switch output.

Output chattering can be prevented by setting the response time.



<Operation>

Press the  or  button in function selection mode to display [F 5].

Press the  button. ↓

**Select response time**  
[rES] and the set value are displayed in turn.  
Press the  or  button to select.

Displayed in turn

 ↔   
Response time                      Set value

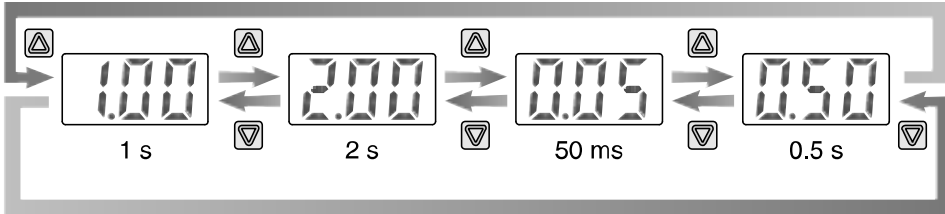

The diagram shows a sequence of four digital displays within a rectangular frame. Each display shows a response time value: '1 s', '2 s', '50 ms', and '0.5 s'. Above each display is an up arrow button, and below each is a down arrow button. Double-headed horizontal arrows connect the displays from left to right, indicating the sequence of selections. A larger double-headed arrow is positioned above the first two displays.



Press the  button. ↓ Return to function selection mode.

[F 5] Selection of response time completed



## ■ [F 6] Display mode

Select instantaneous flow or accumulated flow to be displayed.





<Operation>

Press the  or  button in function selection mode to display [F 6].

Press the  button. ↓

**Select display mode**  
[dSP] and the set value are displayed in turn.  
Press the  or  button to select.

  
Instantaneous flow

 or   
↕  
 or 

  
Accumulated flow



  
Display mode

↔

  
Set value

Press the  button. ↓ Return to function selection mode.

[F 6] Selection of display mode completed

- Accumulated flow measurement starts when the accumulated flow display is selected.
- Although the accumulated flow value is measured up to 999999 L, normally only the lower 3 digits are displayed.  
Press and hold the  button to display the upper 3 digits.
- Press the  and  buttons for 1 second or longer to reset the accumulated flow value.



## ■ [F 7] External input

This function is available when the product includes the external input function

In the default setting, when an input signal is applied, the accumulated flow value is reset to "0".



\*: When using a product without external input function, [---] is displayed and this function cannot be set.

- Accumulated flow external reset: Function to reset the accumulated flow value to "0" when an external signal is input
- Auto-shift: Function where the switch output state is determined by the change in instantaneous flow rate, relative to a reference value set when an external signal is input.
- Auto-shift zero: The same as the auto-shift function, but in addition the display is also set to zero when the external signal is input, and therefore the display shows the change of instantaneous flow from the reference value.

\*: Negative values of flow display and set value are indicated by the leftmost decimal point.

Input signal: Connect the input wire to GND for 30 ms or longer.

<Operation>

Press the  or  button in function selection mode to display [F 7]

Press the  button. ↓

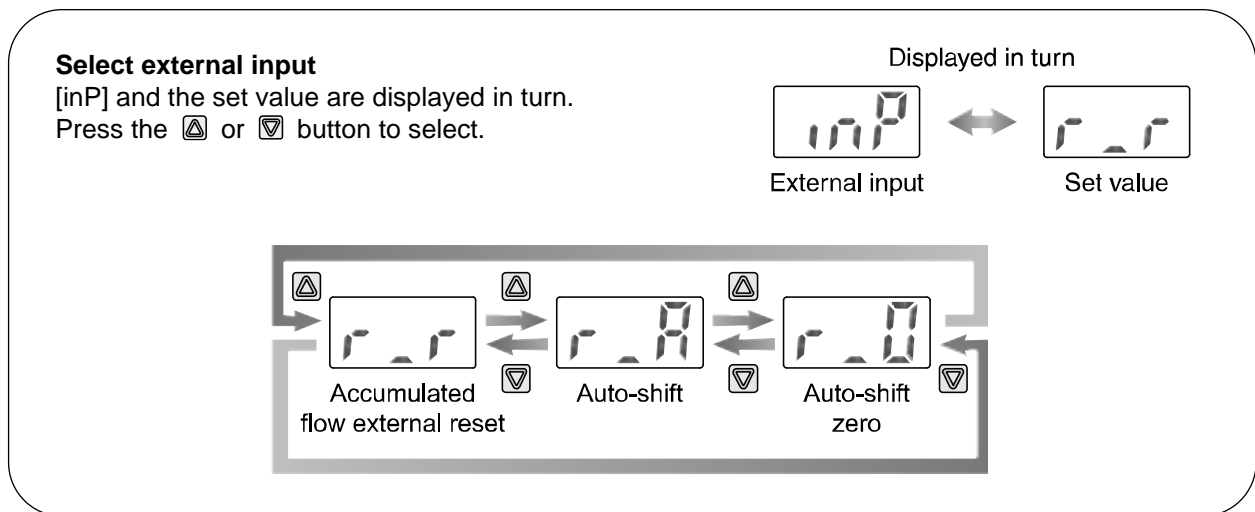

Press the  button. ↓ Return to function selection mode.

[F 7] Selection of external input completed

\*: Please confirm the set value of [F 1] and [F 2] again, after changing the external input setting.

● External input–auto shift, auto shift zero function

Auto-shift and auto-shift zero are functions in which the output and display operate according to the amount of change in the instantaneous flow rate from a reference value set when an external input signal is applied. If auto-shift zero is set, the display value is set to zero when the external signal is input.

See Operation example below.

<E.g.> This function is used during the confirmation of adsorption/release when there are flow rate changes due to source pressure fluctuation or nozzle diameter changes. If there is flow rate variation during adsorption/release and the auto-shift function is not used, then the output will not switch correctly. When the auto-shift function is used, the operation of the switch output is based on the flow rate at the time when auto-shift input is applied. Therefore, reliable output switching will be achieved as long as the auto-shift input is applied during the non-adsorption period.

● When auto-shift is not used

Product: PFM710, switch set value:  $n_1 = 1.6$ ,  $H_1 = 0.4$  (reversed output, hysteresis mode)  
ON/OFF point at these settings ... •ON point:  $n_1$     •OFF point:  $(n_1) + (H_1)$

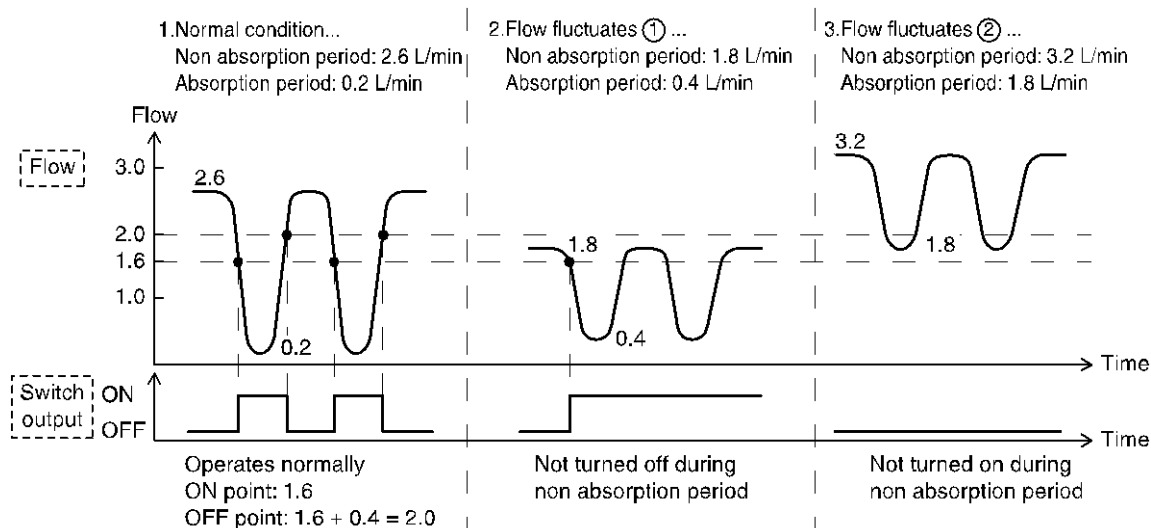

● When auto-shift is used

Product: PFM710, Switch set value:  $n_1 = -1.0$ ,  $H_1 = 0.4$  (reversed output, hysteresis mode)  
ON/OFF point at these settings ... •ON point: (Flow when auto-shift is input) +  $(n_1)$   
•OFF point: (Flow when auto-shift is input) +  $(n_1) + (H_1)$

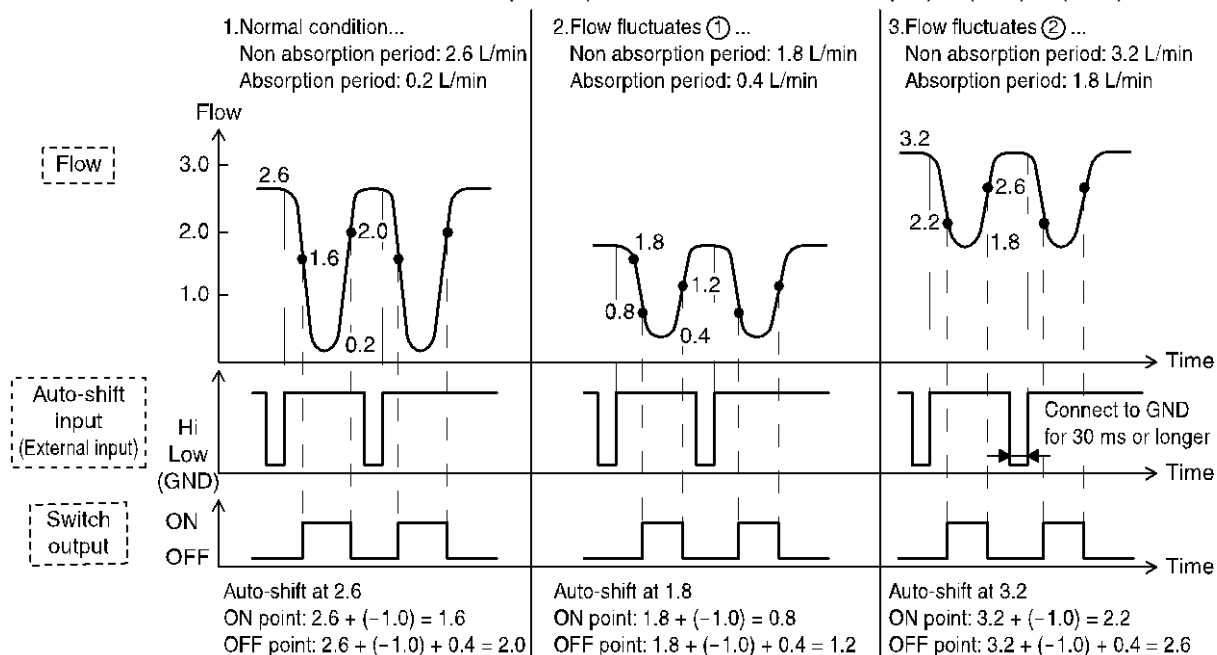

The table below shows an example of the flow displayed when auto-shift zero is selected. Here, a typical condition is used as an example

•Operation example: Flow display before/after auto-shift zero at normal condition.

	Flow display [L/min]							
Before auto-shift	0	1.0	2.6	3.0	...	8.0	9.0	10.0
Input auto-shift at 2.6	↓	↓	↓	↓		↓	↓	↓
After auto-shift	.2.6 *	.1.6 *	0	0.4	...	5.4	6.4	7.4

\*: When the flow value is negative, the left most decimal point indicates the presence of "-".

Set flow range when auto-shift or auto-shift zero is selected is as follows.

•Set flow range when auto-shift or auto-shift zero is selected

Model	PFM710	PFM725	PFM750	PFM711
Set flow range	-10.5 to 10.5 L/min	-26.3 to 26.3 L/min	-52.5 to 52.5 L/min	-105 to 105 L/min

## ■[F 8] Display resolution

This function is only available for the 10 and 100 L/min types.



The minimum setting unit can be changed by selecting the display resolution.

In the default settings, the resolution of the 100 L/min type is 1 L/min, and the 10 L/min type is 0.1 L/min.



\*: When a product other than the 10 L/min type and 100 L/min are used, [---] is displayed and this Function Setting is not available.

\*: This function cannot be used when CFM has been selected by the unit selection function, [---] is displayed.

<Operation>

Press the  or  button in function selection mode to display [F 8].

Press the  button. ↓

**Select display resolution**  
[drE] and the set value are displayed in turn.  
Press the  or  button to select.

  
100-split

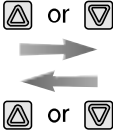
  
↑ or ↓  
↓ or ↑

  
1000-split

  
Display resolution

↔

  
Set value



Press the  button. ↓ Return to function selection mode.

[F 8] Selection of display resolution completed

## ■[F 9] Auto-preset

This function is capable of calculating the approximate set value automatically based on the on-going operation. (OUT1 only)

<Operation>

Press the  or  button in function selection mode to display [F 9].

Press the  button. ↓

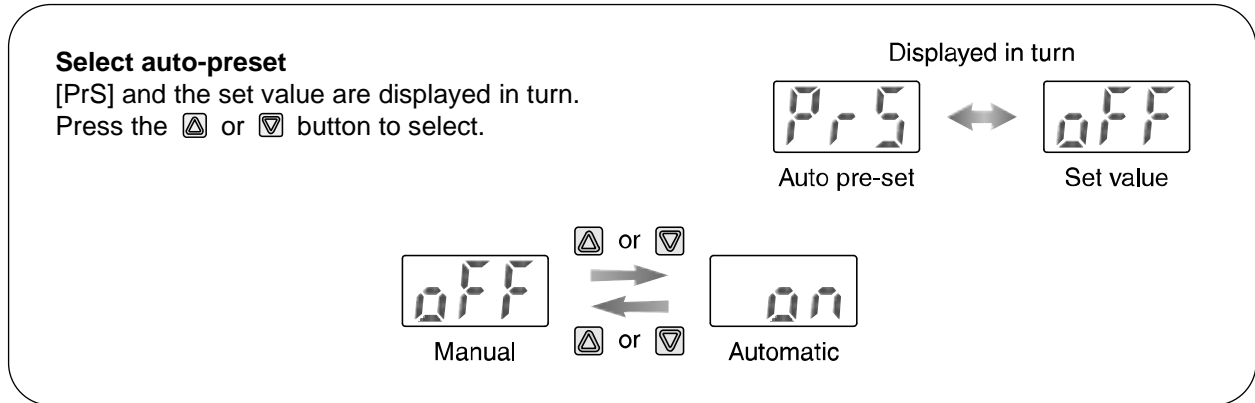

Press the  button. ↓ Return to function selection mode.

[F 9] Selection of auto-preset completed

Press the  button during measurement mode to display [APH].

([APW] for window comparator mode)

Press the  button again, and change the flow rate while the display is flashing.





Hysteresis mode



Window comparator mode

The set value is automatically calculated by pressing the  button. The display will return to measurement mode.

Once setting is performed, auto-preset mode is turned off. It is then possible to confirm the set value by pressing the  button and perform fine adjustment of the set value.

- In auto-preset mode, the set value can be automatically calculated and stored. Auto-preset is a function to automatically calculate the approximate set values according to the actual operating condition. If the  button is pressed during measurement mode after auto-preset function is selected, the display will appear as shown in the table below.

• Display during auto-preset

Output mode	Normal output		Reversed output	
	Hysteresis mode	Window comparator mode	Hysteresis mode	Window comparator mode
Display during auto-preset	APX	APY	AnX	AnY

The Display flashes when the  button is pressed. The flow should be changed while the display is flashing.

Instantaneous flow

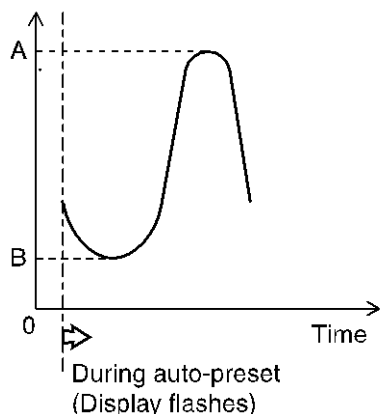

A: Max. flow during auto-preset mode  
B: Min. flow during auto-preset mode

The set value is automatically calculated by pressing the  button. Then, auto-preset mode setting is completed and the display will return to measurement mode. The set values of auto-preset mode are calculated as follows

• Auto-preset set value

	Hysteresis mode	Window comparator mode
Set value	<ul style="list-style-type: none"> <li>• P<sub>1</sub> = A - (A - B)/4</li> <li>• H<sub>1</sub> = (A - B)/2</li> <li>(n<sub>1</sub> = B + <math>\frac{A - B}{4}</math> in reversed output mode)</li> </ul>	<ul style="list-style-type: none"> <li>• P1L = B</li> <li>• P1H = A</li> <li>• H<sub>1</sub> = 5 digit</li> <li>1 digit means the minimum set unit</li> <li>(In reversed output, P1L, P1H becomes n1L, n1H respectively)</li> </ul>

Refer to the list of output operations (page 26) for the setting of hysteresis mode and window comparator mode.



## ■ [F10] Accumulated value hold

The default setting is to clear the accumulated flow value when the power supply is turned off. This function enables the accumulated flow value to be stored in permanent memory every 2 or 5 minutes. The maximum writable limit of the memory device is 1 million cycles, which should be taken into consideration.

For example, if the product is operated 24 hours per day, the life will be as follows:

- Data stored every 5 minutes: 5 minutes x 1 million cycles = 5 million minutes = 9.5 years
- Data stored every 2 minutes: 2 minutes x 1 million cycles = 2 million minutes = 3.8 years

<Operation>

Press the  or  button in function selection mode to display [F10].

Press the  button. ↓

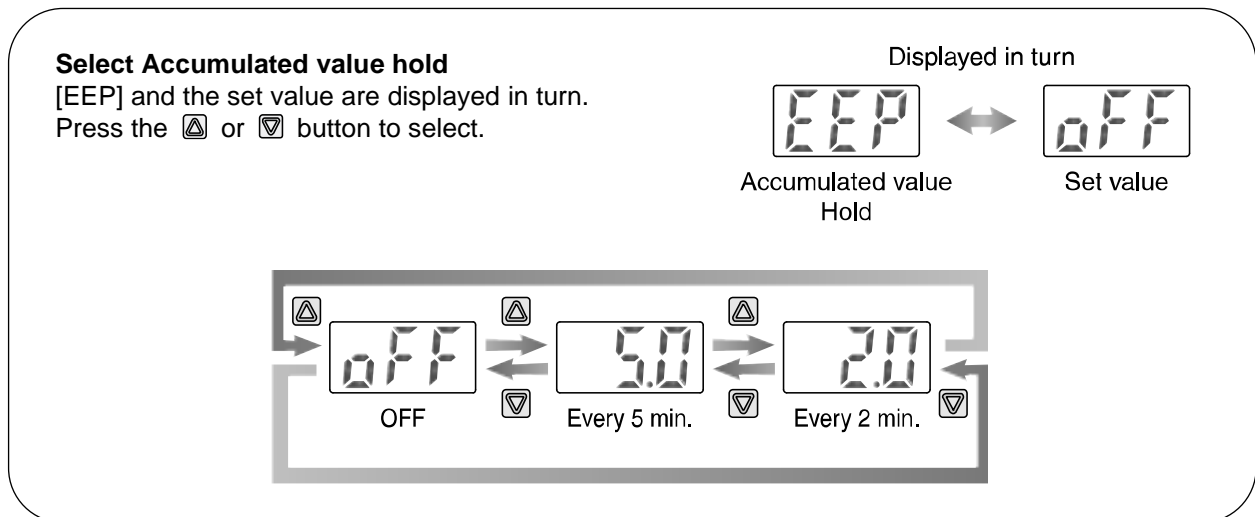

Press the  button. ↓ Return to function selection mode.

[F10] Selection of Accumulated value hold completed

\*: When accumulated flow external reset is repeatedly input, wait for a time longer than the time required to store the value.



## ■[F11] Analogue output filter

This function can only be used on products with the analogue output function.



The response time of the analogue output can be changed by turning off the the analogue output filter. With the filter turned off, a faster response can be obtained.

\*: When using a product without analogue output function, [---] is displayed and this function is not available.

<Operation>

Press the  or  button in function selection mode to display [F11].

Press the  button. ↓

**Select Analogue output filter**  
[AFL] and the set value are displayed in turn.  
Press the  or  button to select.

Displayed in turn

AFL

↔

00

Analogue output filter      Set value

00

↔

OFF

With filter      Without filter  
(Response time 1.5 s)      (Response time 100 ms)

Press the  button. ↓ Return to function selection mode.



[F11] Selection of Analogue output filter completed



## ■[F12] Power saving mode

In power saving mode, the display can be turned off to reduce power consumption.  
When the product is left for 30 seconds with no button operations, it will enter power saving mode.  
The decimal point flashes during operation.

<Operation>

Press the  or  button in function selection mode to display [F12].

Press the  button. ↓

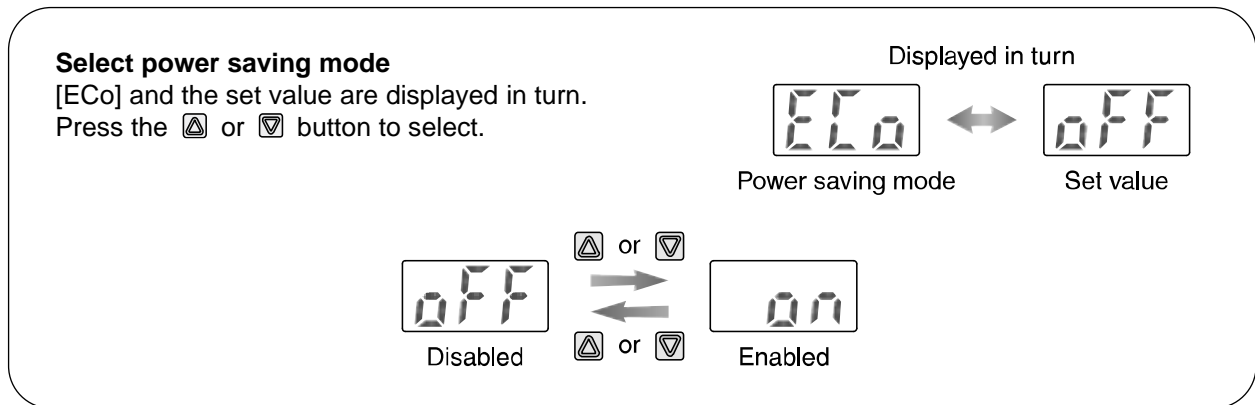

Press the  button. ↓ Return to function selection mode.

[F12] Selection of power saving mode completed

In power saving mode, any key operation will return the normal display.  
If there is no key operations for 30 seconds, the display will return to power saving mode.  
(only in the measurement mode.)



During power saving mode, only the decimal points will flash.



## ■[F13] Security code

A security code can be selected, which must be entered to unlock the keys when the keys are locked. Refer to key-lock function (page 46).

<Operation>

Press the  or  button in function selection mode to display [F13].

Press the  button. ↓

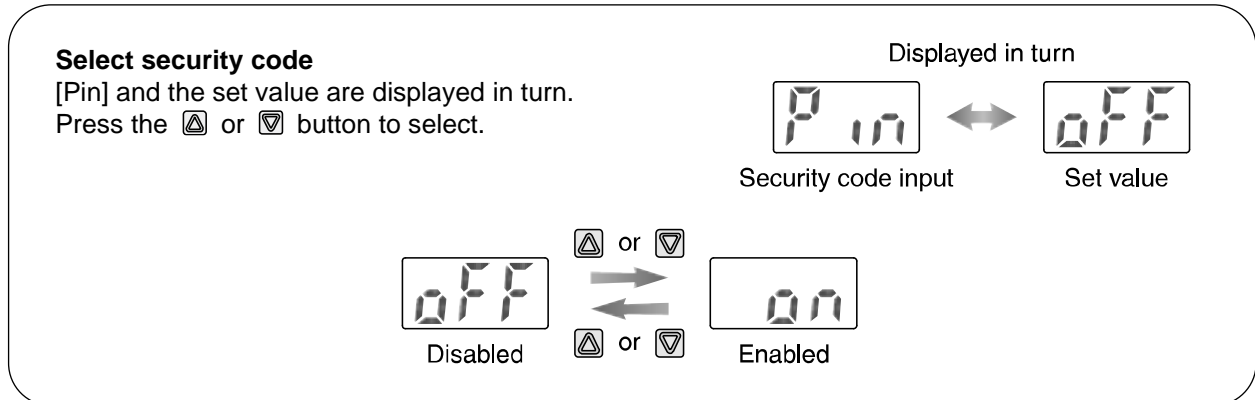



Press the  button. ↓ Return to function selection mode.

[F13] Selection of security code completed

## ■ [F98] Setting of all functions

All functions can be set one after the other, without having to select each one separately from the function selection mode.

<Operation>

Press the  or  button in function selection mode to display [F98].

Press the  button. ↓

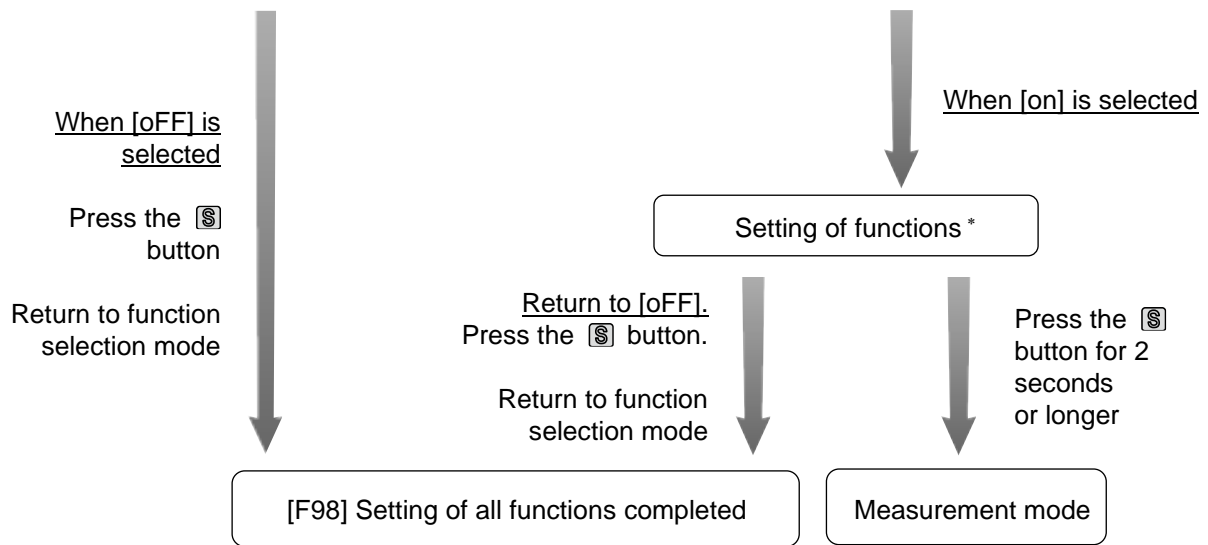
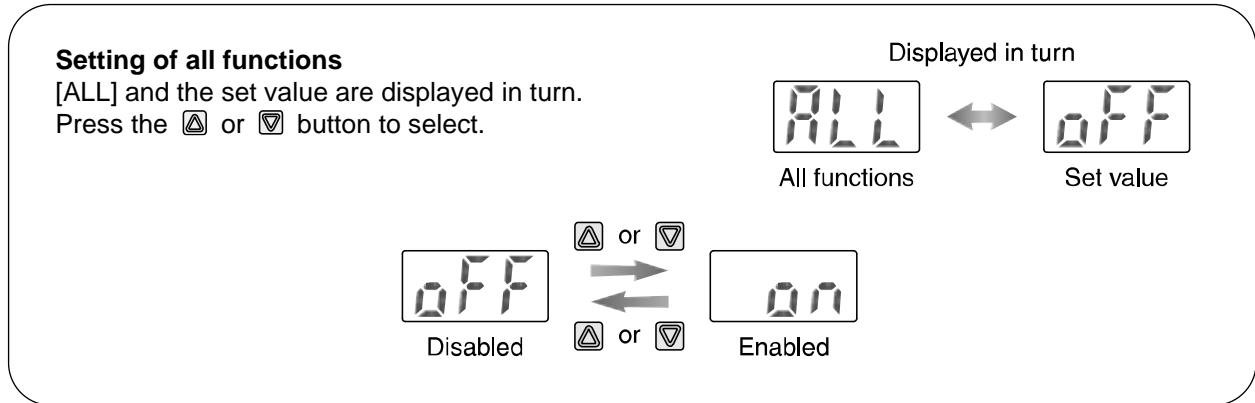

\*: Setting of functions

Every time the  button is pressed, the next function is displayed in order (refer to the following table).

Set by using the  or  buttons.

Refer to each paragraph for the setting details.



### Order of Function Setting

Order	Function	Applicable model
1	Unit selection function	Models with unit selection function
2	Output mode (OUT1)	All models
3	Reversed output (OUT1)	All models
4	Input of set value (OUT1)	All models
5	Setting of hysteresis (OUT1)	All models
6	Display colour	All models
7	Output mode (OUT2)	Models with 2 x NPN output, 2 x PNP output
8	Reversed output (OUT2)	
9	Input of set value (OUT2)	
10	Setting of hysteresis (OUT2)	
11	Operating fluid	All models
12	Reference condition	All models
13	Response time	All models
14	Display mode	All models
15	External input	Models with external input
16	Display resolution	10 or 100 [L/min] models
17	Auto-preset	All models
18	Accumulated value Hold	All models
19	Analogue output filter	Models with analogue output
20	Power saving mode	All models
21	Security code	All models

## ■[F99] Reset to the default settings

The factory default settings can be restored.

<Operation>

Press the  or  button in function selection mode to display [F99].



Press the  button. ↓

### Reset to the default setting

[ini] and the set value are displayed in turn.

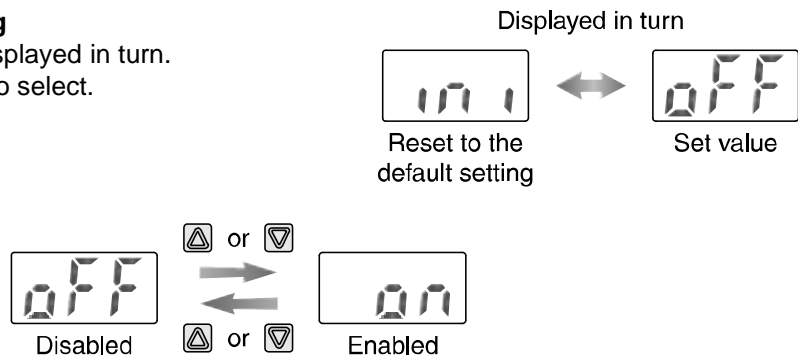
Press the  or  button to select.



Press the  and  buttons simultaneously for 5 seconds or longer when [ on ] is displayed. ↓ Return to function selection mode.

[F99] Reset to the default setting completed

## Other Settings

### ●Peak/Bottom value display

The maximum (minimum) instantaneous flow, from when the power was supplied to this moment, is detected and updated.



In the peak/(bottom) value display mode, the maximum (minimum) instantaneous flow can be displayed.

For peak value display mode, when the  button is pressed for 1 second or longer, the maximum flow will be displayed flashing, and is held.

To release holding the peak value display, press the  button for 1 second or longer to return to measurement mode.

For bottom value display mode, when the  button is pressed for 1 second or longer, the minimum flow will be displayed flashing, and is held.



To release holding the bottom value display, press the  button for 1 second or longer to return to measurement mode.

If the  and  buttons are pressed simultaneously for 1 second or longer while the flow is being held, the peak (bottom) value is reset.

### ●Zero Clear

The displayed value can be adjusted to "0" when the measured flow is within  $\pm 10\%$  F.S. of the zero point at the time of shipment from the factory.

(A tolerance of  $\pm 1$  digit may apply due to individual product differences)

Press the  and  buttons simultaneously for 1 second or longer, to clear the display to "0". The display will return to measurement mode automatically.

The accumulated value is "0" when accumulated flow is displayed.

### ●Key-lock function

The key lock function is used to prevent errors occurring due to unintentional changes of the set values. If a button operation is performed while the key lock setting is ON, [LoC] is displayed for approximately 1 second.

<Operation -Without security code input->

#### ●Locking

1. Press the  button for 5 seconds or longer in measurement mode. [UnL] will be displayed.



2. Press the  or  button to select keys lock [LoC].

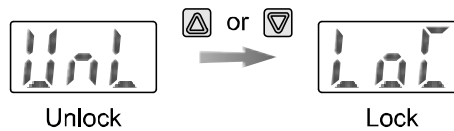



3. Press the  button to store the setting and return to measurement mode.

#### ●Unlocking

1. Press the  button for 5 seconds or longer in measurement mode. [LoC] will be displayed.



2. Press the  or  button to select keys unlock [UnL].

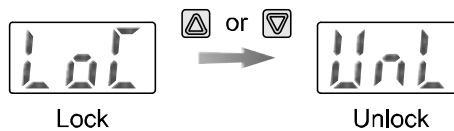

3. Press the  button to store the setting and return to measurement mode.

<Operation -With security code input->

### •Locking

1. Press the  button for 5 seconds or longer in measurement mode. [UnL] will be displayed.

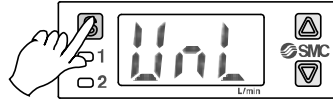

2. Press the  or  button to select keys lock [LoC].

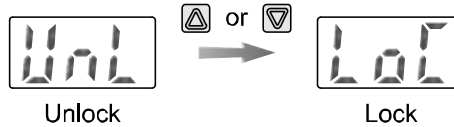



3. Press the  button to store the setting and return to measurement mode.

### •Unlocking

1. Press the  button for 5 seconds or longer in measurement mode. [LoC] will be displayed.



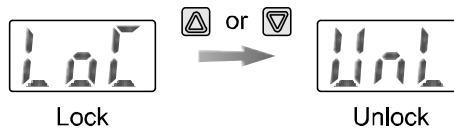

2. Press the  or  button to select keys unlock [UnL].



3. When the  button is pressed, the security code must now be entered.



#### How to enter the security code

The first digit will start flashing. Press the  or  button to select a value.



Press the  button to set, and the next digit will start flashing.

If the  button is pressed at the last digit, the first digit will start flashing again.

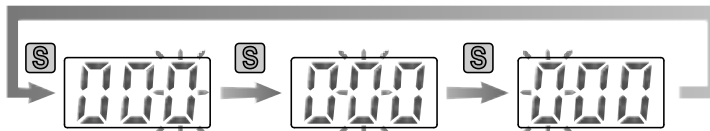
After the setting is completed, press and hold the  button for 1 second or longer.



4. If the security code entered is correct, the display will change to [UnL].

Press any of the ,  or  buttons to release the key-lock and return to measurement mode.

If the security code entered is incorrect, [FAL] will be displayed and the security code must be entered again.

If an incorrect security code is entered three times, [LoC] is displayed and the display will return to measurement mode.



\*: If a key operation is not performed for 30 seconds while entering the security code, the measurement mode will return.



## How to change the security code

At the time of shipment, the security code is set to [000], but this can be changed to any number.

<Operation>



1. Perform the key locking procedure, followed by the first 3 steps of the key unlocking procedure
2. When [UnL] is displayed, press the  and  buttons simultaneously for 5 seconds or longer.

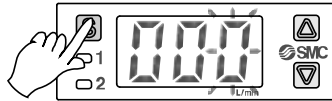

[000] is displayed and a new security code can now be entered.



### How to enter the security code

The first digit will start flashing. Press the  or  button to select a value.



Press the  button to set, and the next digit will start flashing.

If the  button is pressed at the last digit, the first digit will start flashing again.

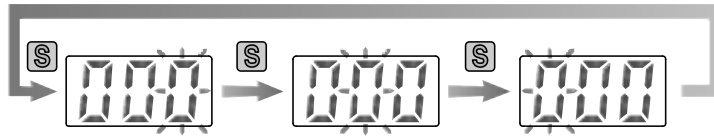
After the setting is completed, press and hold the  button for 1 second or longer.



The new security code will be displayed.

At this time, if the  or  button is pressed, any security code changes are lost, and the change of security code procedure must be repeated.

3. After checking the security code is as required, press the  button.  
The display will return to measurement mode.

## Maintenance

### **How to reset the product after a power cut or forcible de-energizing**

The setting of the product will be retained as it was before a power cut or de-energizing.

The output condition is also basically recovered to that before a power cut or de-energizing, but may change depending on the operating environment.

Therefore, check the safety of the whole installation before operating the product.

## Troubleshooting

### Troubleshooting

If an operation failure occurs with the product, use the chart below to find out the cause of the problem. If none of the countermeasures seem to be applicable, or a replacement product operates normally when installed, the product may be faulty. A product can be damaged by the operating environment (system configuration etc). If the product seems to be faulty, please contact SMC.



#### ●Faults and countermeasures

Fault	Status	Possible cause	Item to check	Countermeasure
Incorrect display	No Display	Incorrect wiring	Check that the brown and blue wires are connected to DC (+) and DC (-) respectively.	Correct the wiring.
		Loose connector	Check the connectors.	Correct the connector wiring.
	Display is flashing	Peak/bottom value display mode is selected	Check if the peak value or bottom value display mode has been selected.	Refer to "Peak/bottom value display" (page 45), and remove the setting.
	Display is not stable	Foreign matter has entered the flow passage or adhered to the sensor	(1) Check if any foreign matter has entered the flow passage. (2) Check if there is foreign matter on the mesh.	Install a filter or mist separator on the IN side.
		Piping connected backwards	Check that the fluid flow is in the same direction as marked on the product body.	Ensure the product is mounted so that the fluid flow matches the direction marked on the product body.
		Flow is pulsing	Check if there is any supply pressure fluctuation or pressure pulsation due to the characteristics of the source compressor (or pump).	Install an accumulator tank to reduce the pressure fluctuation. Change the pressure source to one that has less pulsation.
	Incorrect display	Foreign matter has entered the flow passage or adhered to the sensor	(1) Check if any foreign matter has entered the flow passage. (2) Check if there is foreign matter on the mesh.	Install a filter or mist separator on the IN side.
		Piping in the reverse direction	Check that the fluid flow is in the same direction as marked on the product body.	Ensure the product is mounted so that the fluid flow matches the direction marked on the product body.
		Incorrect display units setting	Check the display unit selected.	Select the appropriate units.

Fault	Status	Possible cause	Item to check	Countermeasure
Incorrect display	Incorrect display	Incorrect flow range selected	Check the flow range of the model used.	Select a model with the appropriate flow range.
		Air leakage	Check for air leakage due to loose piping or insufficient sealant, etc.	Reconnect the piping with the specified tightening torque and re-apply the sealant tape.
	Fluid does not flow	The flow adjustment valve is closed	Check the flow adjustment valve.	Open the flow adjustment valve and adjust the flow.
Incorrect output	No output	Incorrect wiring	Check that the brown, blue, black and white wires are connected correctly.	Correct the wiring.
		Connector is disconnected	Check the connectors.	Correct the connector wiring.
	Output is unstable	Foreign matter has entered the flow passage or adhered to the sensor	(1) Check if any foreign matter has entered the flow passage. (2) Check if there is foreign matter on the mesh.	Install a filter or mist separator on the IN side.
		Piping in the reverse direction	Check that the fluid flow is in the same direction as marked on the product body.	Ensure the product is mounted so that the fluid flow matches the direction marked on the product body.
		Flow is pulsing	Check if there is any supply pressure fluctuation or pressure pulsation due to the characteristics of the source compressor (or pump).	Install an accumulator tank to reduce the pressure fluctuation. Change the pressure source to one that has less pulsation.
		Air leakage	Check for air leakage due to loose piping or insufficient sealant, etc.	Reconnect the piping with the specified tightening torque and re-apply the sealant tape.
		Hysteresis value too low	Check the hysteresis set value.	Increase the hysteresis set value.

Fault	Status	Possible cause	Item to check	Countermeasure
Buttons not operating	No reaction when the buttons are pressed	The keys are locked	Check if [Loc] is displayed when the buttons are pressed.	Release the key-lock function. (Refer to 46)
Incorrect operation of the flow adjustment valve	The flow adjustment valve fails to adjust the flow	The flow adjustment valve is locked	Check the lock ring on the flow adjustment valve.	Loosen the lock ring, and then adjust the flow adjustment valve.
		Insufficient supply pressure	Check the supply pressure and the flow characteristics of the flow adjustment valve.	Increase the supply pressure.
External input does not operate	No reaction to the external input	Incorrect wiring	Check that the brown, blue, black and white wires are connected correctly.	Correct the wiring.
		The input signal duration is too short	Check that the white input wire is connected to GND for 30 ms or more.	For external inputs, the white wire should be connected to GND for 30 ms or more.

## ■ Error indication

Error Name	Display	Type	Troubleshooting
Flow error	HHH	The flow has exceeded the upper limit of the flow display range.	Reduce the flow.
	LLL	There is a flow of 5% or more in the wrong direction.	Ensure the flow is in the correct direction.
Over current error	Er1	The switch output load current (OUT1) has exceeded 80 mA.	Turn off the power supply and remove the cause of the over current. Then supply the power again.
	Er2	The switch output load current (OUT2) has exceeded 80 mA.	
System error	Er0	The product has lost the factory adjustment settings. The internal circuit may be damaged.	Stop operation immediately and contact SMC.
	Er3	System error. The product has failed to store the data, or the internal circuit may be damaged.	Turn the power off and turn it on again, then repeat the Function Setting.
Zero clear error	Er4	The zero clear function has been performed while the fluid is flowing. "Er4" will be displayed for 1 second.	Perform the zero clear function again under no flow conditions.
Accumulated flow error	 Accumulated flow displayed (flashing)	Accumulated flow range has been exceeded.	Reset the accumulated flow (pressing  and  buttons simultaneously for 1 second or more). (Refer to page 45.)

\*: If the error cannot be reset after the above measures are taken, then please contact SMC.

# Specification

## ■ Specifications

Model		PFM710	PFM725	PFM750	PFM711	
Applicable fluid		Dry air, N <sub>2</sub> , Ar, CO <sub>2</sub> (air quality class to ISO8573-1 1.1.2 to 1.6.2)				
Rated flow range	Dry air, N <sub>2</sub> , Ar	0.2 to 10 L/min	0.5 to 25 L/min	1 to 50 L/min	2 to 100 L/min	
	CO <sub>2</sub>	0.2 to 5 L/min	0.5 to 12.5 L/min	1 to 25 L/min	2 to 50 L/min	
Instantaneous flow	Display flow range	Dry air, N <sub>2</sub> , Ar	0.2 to 10.5 L/min * <sup>1</sup>	0.5 to 26.3 L/min	1 to 52.5 L/min	2 to 105 L/min * <sup>2</sup>
		CO <sub>2</sub>	0.2 to 5.2 L/min	0.5 to 13.1 L/min	1 to 26.2 L/min	2 to 52 L/min
	Set flow range	Dry air, N <sub>2</sub> , Ar	0 to 10.5 L/min * <sup>1</sup>	0 to 26.3 L/min	0 to 52.5 L/min	0 to 105 L/min * <sup>2</sup>
		CO <sub>2</sub>	0 to 5.2 L/min	0 to 13.1 L/min	0 to 26.2 L/min	0 to 52 L/min
Min. setting/display unit		0.01 L/min	0.1 L/min	0.1 L/min	0.1 L/min	
Accumulated flow	Setting/display flow range * <sup>3</sup>	0 to 999999 L				
	Min. setting/display unit	1 L				
Accumulated flow volume per pulse		0.1 L/Pulse	0.1 L/Pulse	0.1 L/Pulse	1 L/Pulse	
Display unit		Instantaneous flow: L/min, CFM x 10 <sup>-2</sup> Accumulated flow: L, ft <sup>3</sup> x 10 <sup>-1</sup>				
Reference condition * <sup>4</sup>		Standard condition (ANR), Normal condition (NOR)				
Repeatability		±1%F.S. max. (fluid: Dry air) Analogue output accuracy: ±3%F.S. max.				
Pressure characteristics		±5%F.S. max. (0.35 MPa reference)				
Temperature characteristics		±2%F.S. max. (15 to 35 °C) ±5%F.S. max. (0 to 15 °C, 35 to 50 °C)				
Rated pressure range		-70 to 750 kPa				
Proof pressure		1 MPa				
Switch output		NPN or PNP open collector output				
	Max. load current	80 mA				
	Max. load voltage	28 VDC (NPN output)				
	Internal voltage drop	NPN output: 1 V (at 80 mA), PNP output: 1.5 V or less (at 80 mA)				
	Response time	1 s (50 ms, 0.5 s, 2 s are selectable)				
	Output protection	Short circuit protection				
	Output mode	Hysteresis mode, window comparator mode, Accumulated output mode, Accumulated pulse output mode				
	Hysteresis	Variable				
Analogue output	Response time	1.5 s				
	Voltage output	Output voltage: 1 to 5 V Output impedance: 1 kΩ				
	Current output	Output current: 4 to 20 mA Max. load impedance: 600 Ω (24 VDC) Min. load impedance: 50 Ω				
	Accuracy	±5%F.S. max.				

Model	PFM710	PFM725	PFM750	PFM711
External input	Voltage free input (reed switch or solid state), 30 ms or more			
Display accuracy	±3%F.S. max. (fluid: Dry air)			
Display	3 digits, 7 segment, dual colour display (red/green)			
Indicator LED	LED is ON when output is ON OUT1: Green OUT2: Red			
Supply voltage	24 VDC± 10%			
Power consumption	55 mA			
Environment	Enclosure	IP40		
	Operating fluid temperature	0 to 50 °C (no freezing or condensation)		
	Operating temp. range	Operating: 0 to 50 °C, Stored: -10 to 60 °C (no freezing or condensation)		
	Operating humidity range	Operating, stored 35 to 85% R.H. (no condensation)		
	Withstand voltage	1000 VAC, 1 min. between terminals and case		
	Insulation resistance	50 MΩ min. (at 500 VDC) between terminals and case		
Standards	CE/UKCA marked, UL (CSA)			

\*1: If the resolution is set to 1000 for 10 L/min type, the display upper limit will be [9.99 L/min].

\*2: If the resolution is set to 1000 for 100 L/min type, the display upper limit will be [99.9 L/min].

\*3: When using the Accumulated flow hold function, calculate the product life according to the operating conditions, and use the product within its life. The limit of the number times the memory can be written to is 1 million times. If the product is operated 24 hours per day, the life will be as follows.

· Data stored every 5 minutes: 5 minutes x 1 million cycles = 5 million minutes = 9.5 years

· Data stored every 2 minutes: 2 minutes x 1 million cycles = 2 million minutes = 3.8 years

If the accumulated flow external reset is repeatedly input, the life will be shorter than the calculated life.

\*4: Standard condition (ANR): Flow measurement reference condition 101.3 kPa, 20 °C, 65%R.H.

Normal condition (NOR): Flow measurement reference condition 101.3 kPa, 0 °C.



### Piping port specifications

Model		01	02	N01	N02	F01	F02	C4	C6	C8	N7	
Thread type (Port size)		Rc 1/8	Rc 1/4	NPT 1/8	NPT 1/4	G 1/8	G 1/4	φ4 (5/32") One- touch fitting	φ6 One- touch fitting	φ8 (5/16") One- touch fitting	φ1/4 One- touch fitting	
Weight	Straight without flow adjustment valve	95 g					125 g	55 g				
	Bottom entry without flow adjustment valve	105 g					135 g	65 g				
	Straight with flow adjustment valve	135 g					165 g	95 g				
	Bottom entry with flow adjustment valve	145 g					175 g	105 g				
Material of parts in contact with fluid		LCP, PBT, brass (electroless nickel plating), HNBR (+ fluoro coating), FKM (+ fluoro coating), Si, Au, SUS304										

### Cable specifications

Conductor	Nominal cross section area	AWG26
	Individual wire diameter	approx. 0.50 mm
Insulator	Outside diameter	approx 1.00 mm
	Colours	Brown, White, Black, Blue
Sheath	Material	Lead free heat and oil resistance PVC
	Outer diameter	approx. φ3.5 mm

## ■ Characteristics data

### ● Analogue output characteristics

\*: Analogue output at maximum rated flow rate when CO<sub>2</sub> is selected is 3 [V] for the voltage output type and 12 [mA] for the current output type.

Analogue voltage output (1 to 5 V)

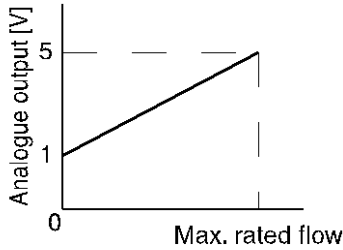

Analogue current output (4 to 20 mA)

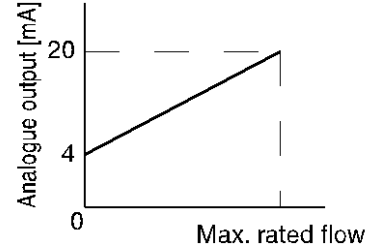

Model	Max. rated flow [L/min]
PFM710-□-C/E	10 (5)
PFM725-□-C/E	25 (12.5)
PFM750-□-C/E	50 (25)
PFM711-□-C/E	100 (50)

\*: ( ) : Fluid: CO<sub>2</sub>

Model	Max. rated flow [L/min]
PFM710-□-D/F	10 (5)
PFM725-□-D/F	25 (12.5)
PFM750-□-D/F	50 (25)
PFM711-□-D/F	100 (50)

\*: ( ) : Fluid: CO<sub>2</sub>

### ● Flow adjustment needle revolution - Flow characteristics (reference value)

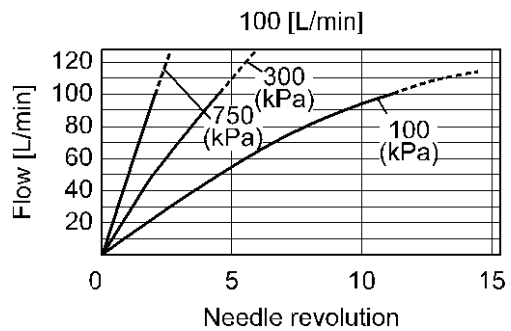
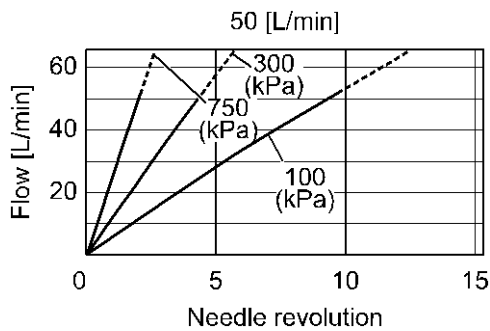
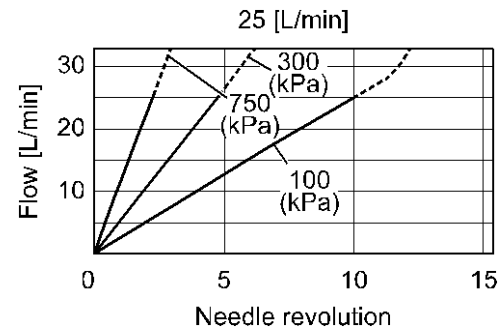
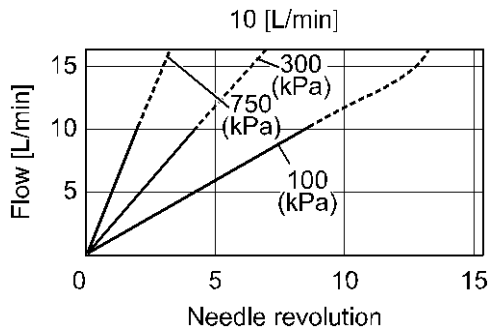

● Pressure loss (at 350 [kPa])

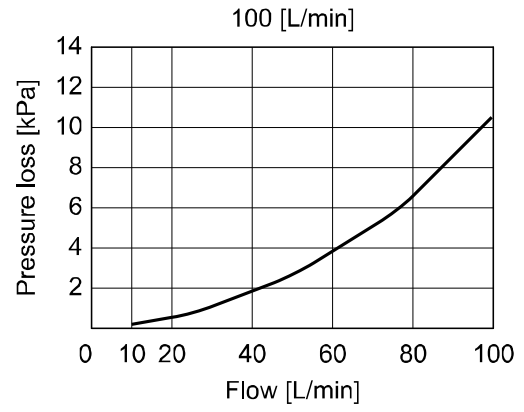
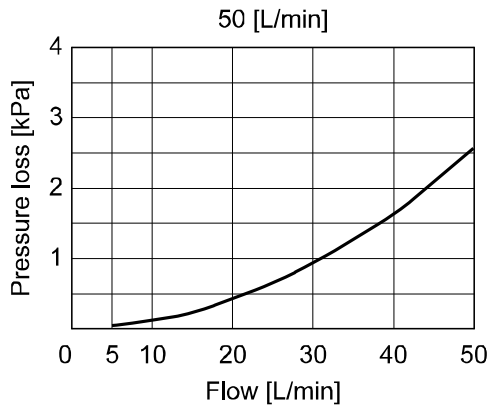
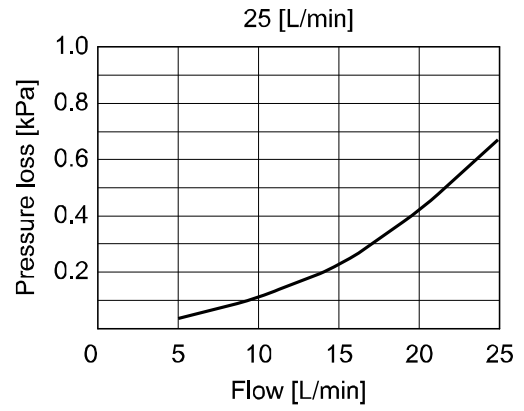
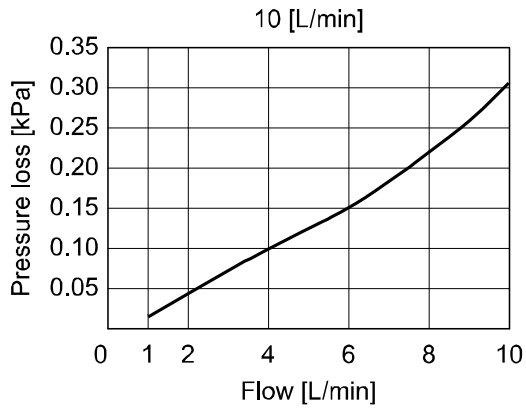

## ■Dimensions

PFM7□□-(N)01/(N)02/F01

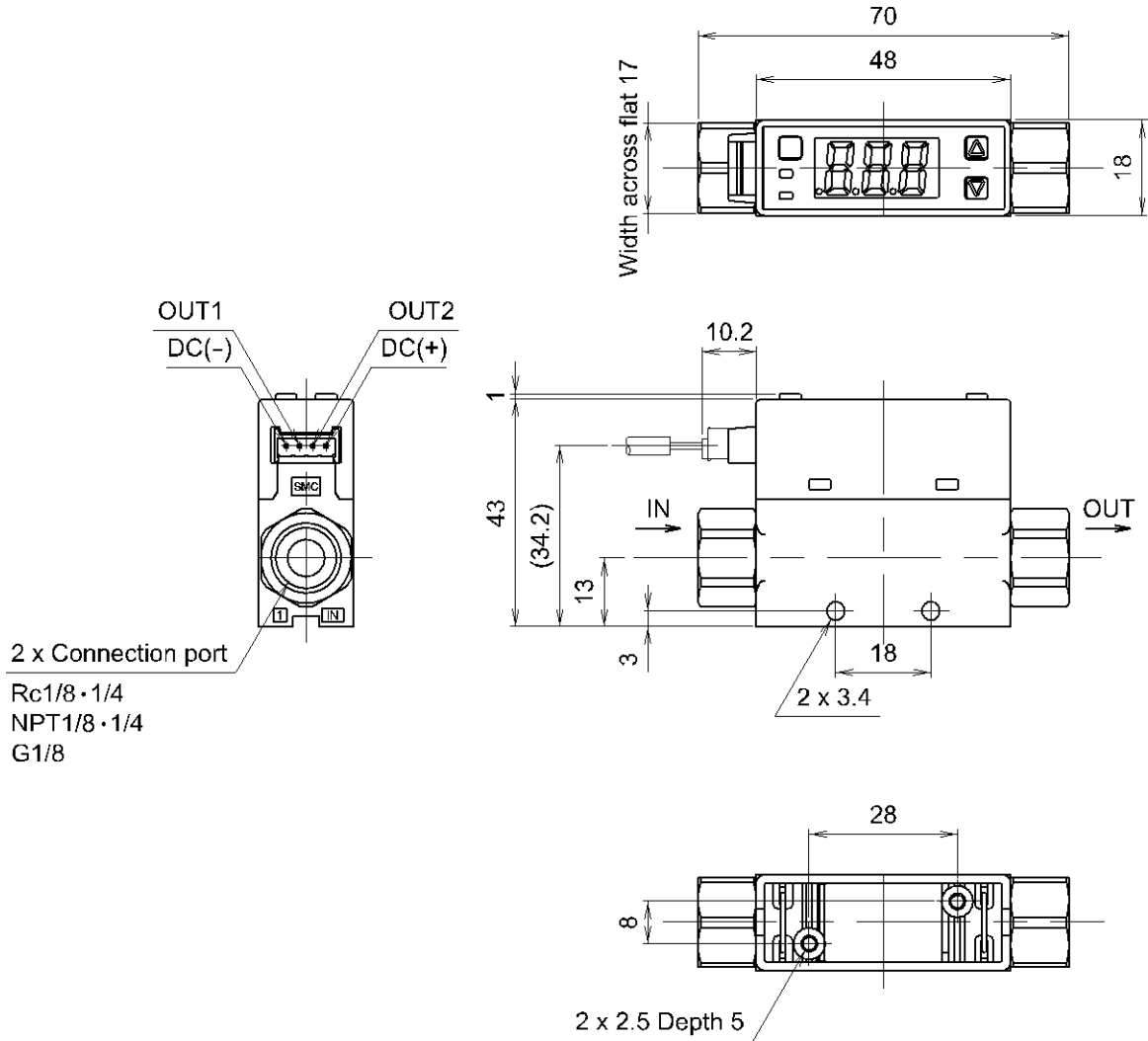

PFM7□□-(N)01L/(N)02L/F01L

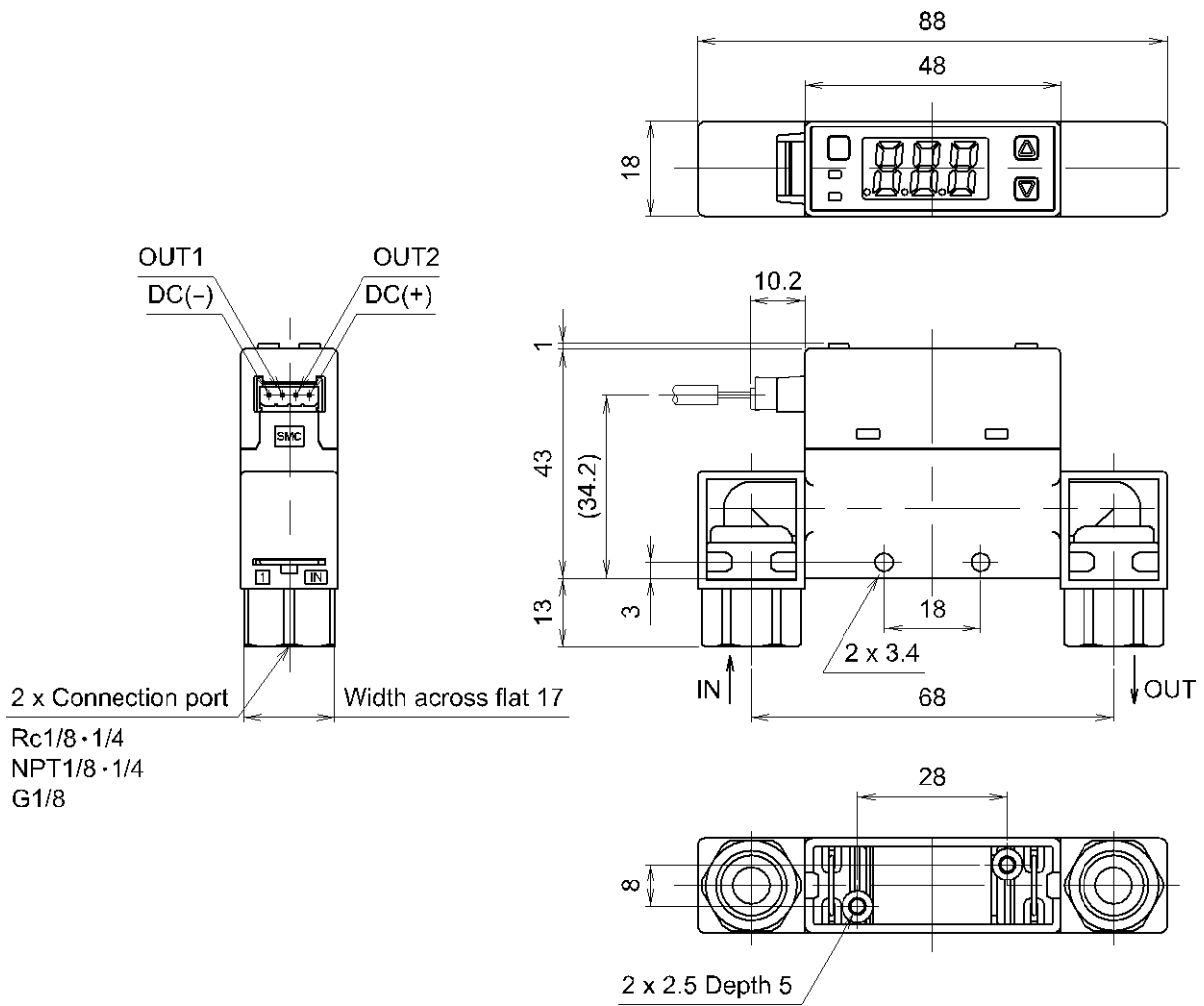

PFM7□□S-(N)01/(N)02/F01

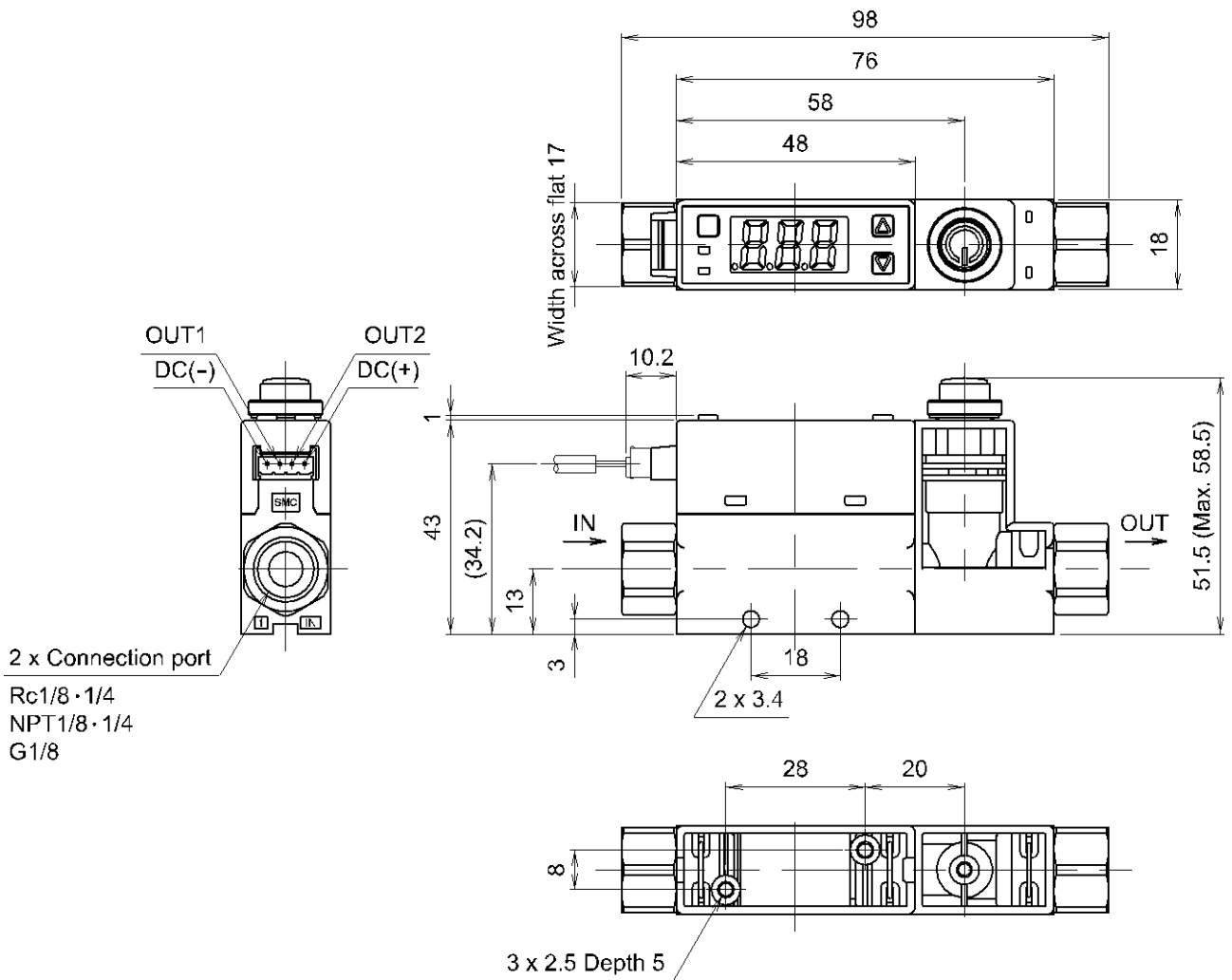

PFM7□□S-(N)01L/(N)02L/F01L

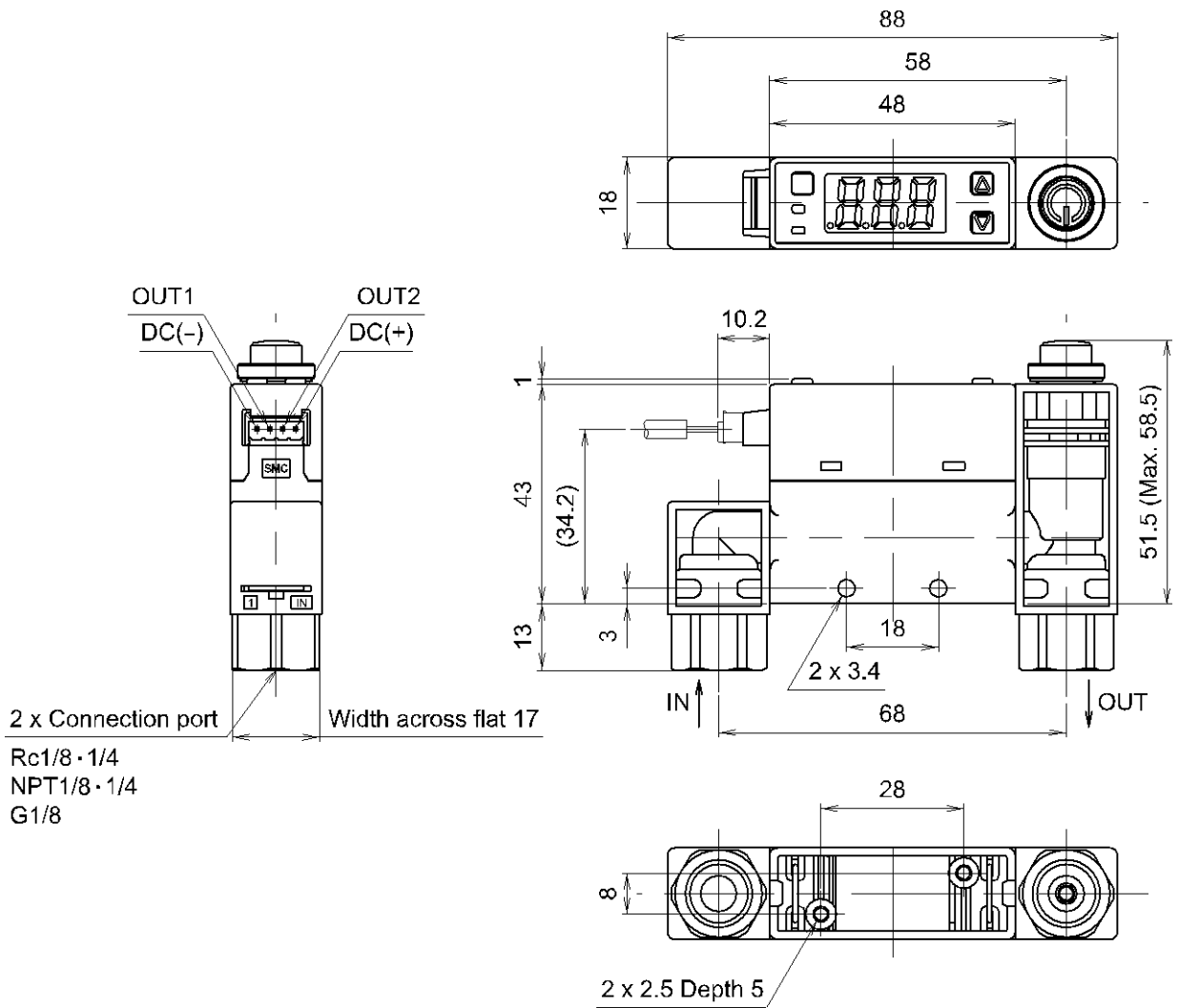

PFM7□□-F02

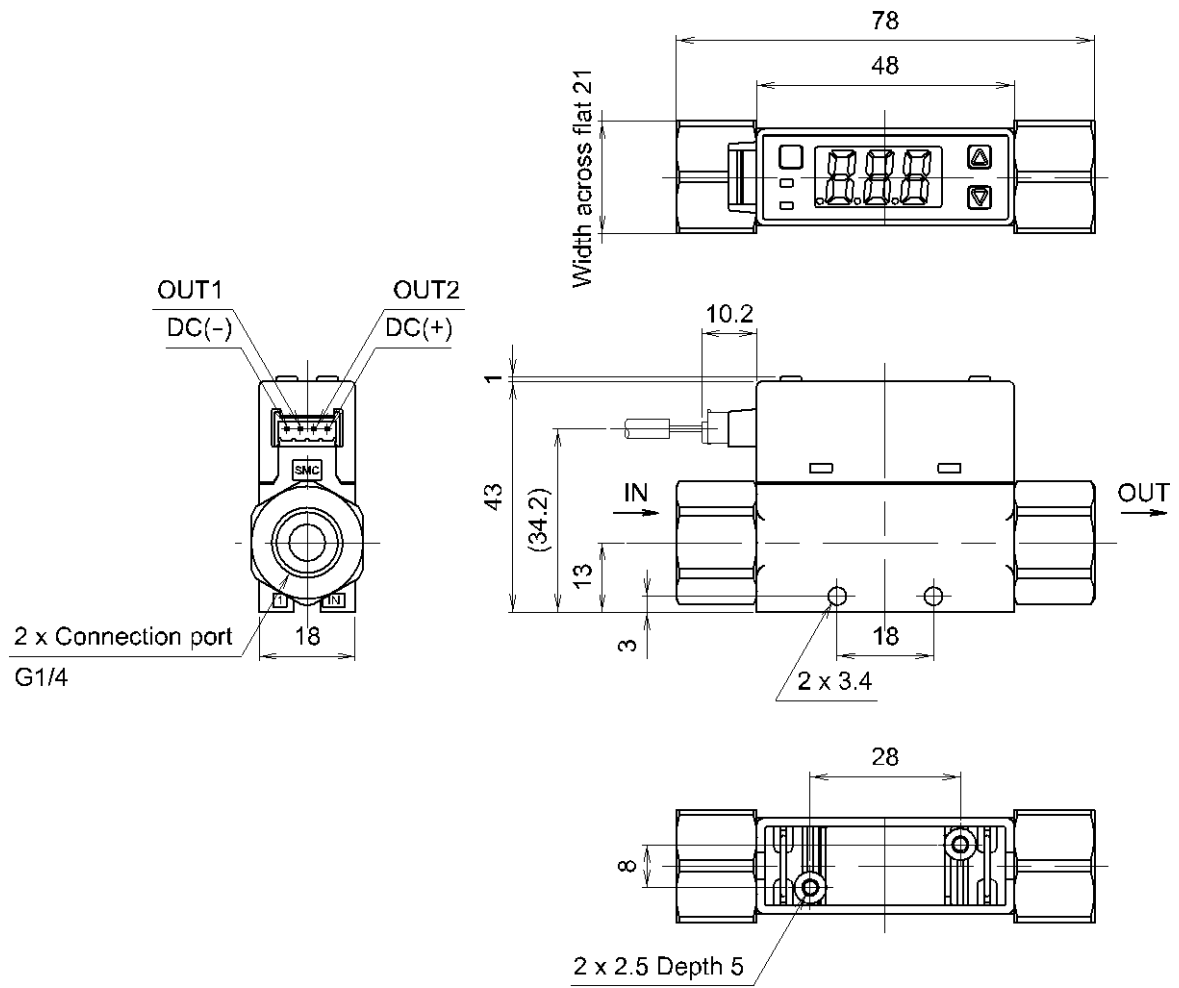



PFM7□□-F02L

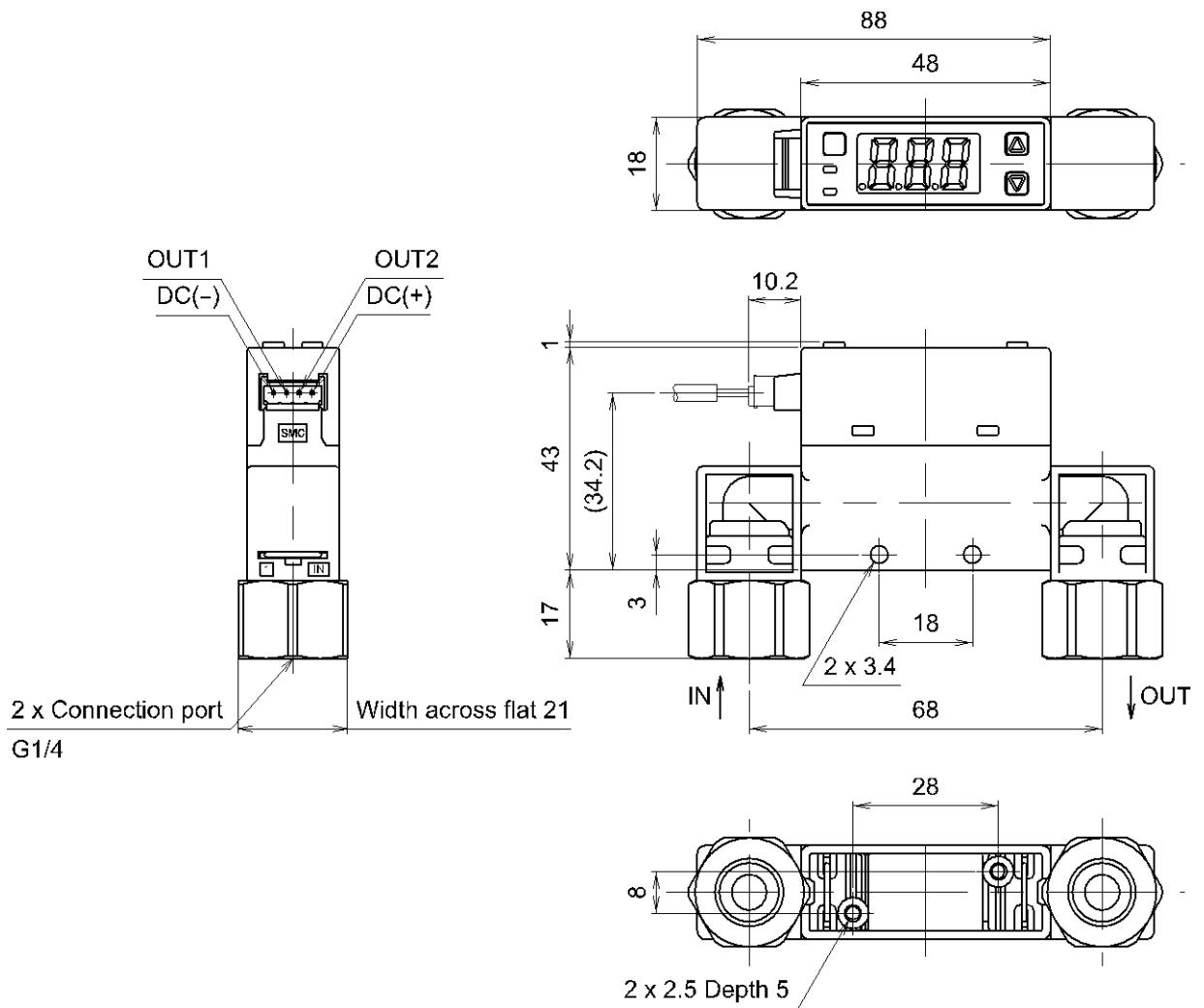

PFM7□□S-F02

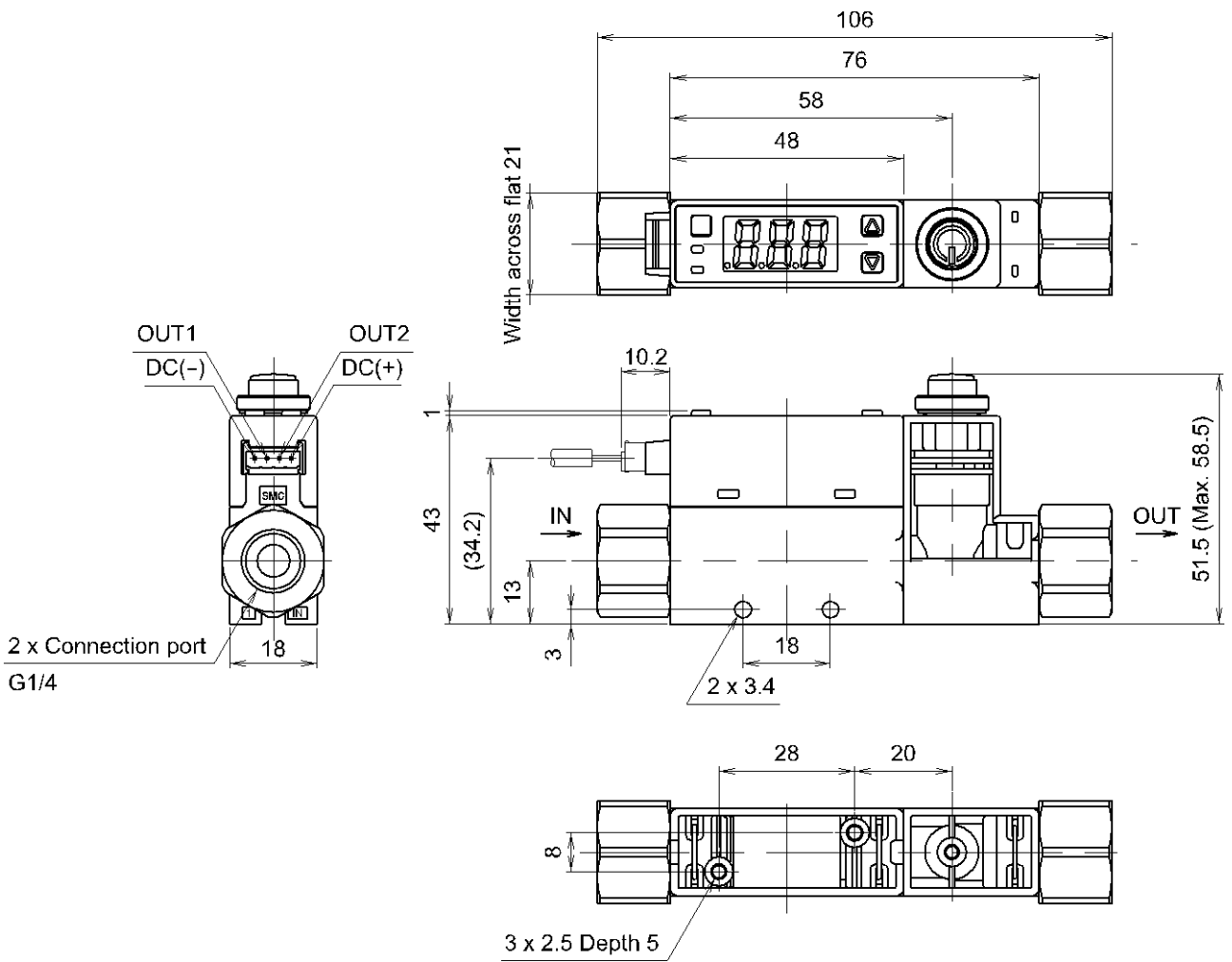

PFM7□□S-F02L

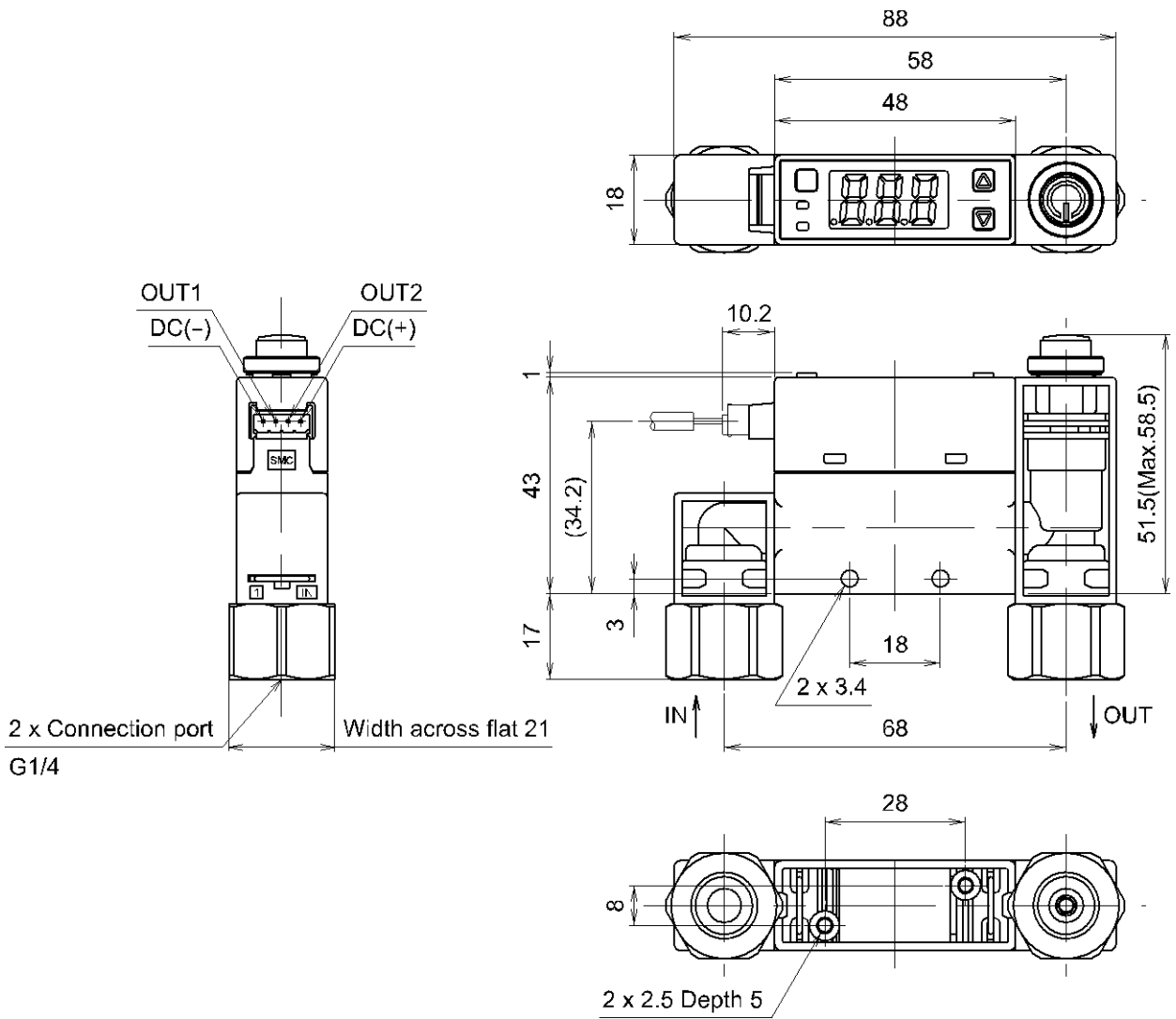

PFM7□□-C4/C6/C8/N7

Model	A
C4	64.2
C6	64.6
C8	68
N7	64.6

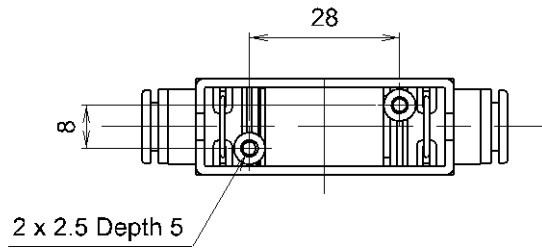
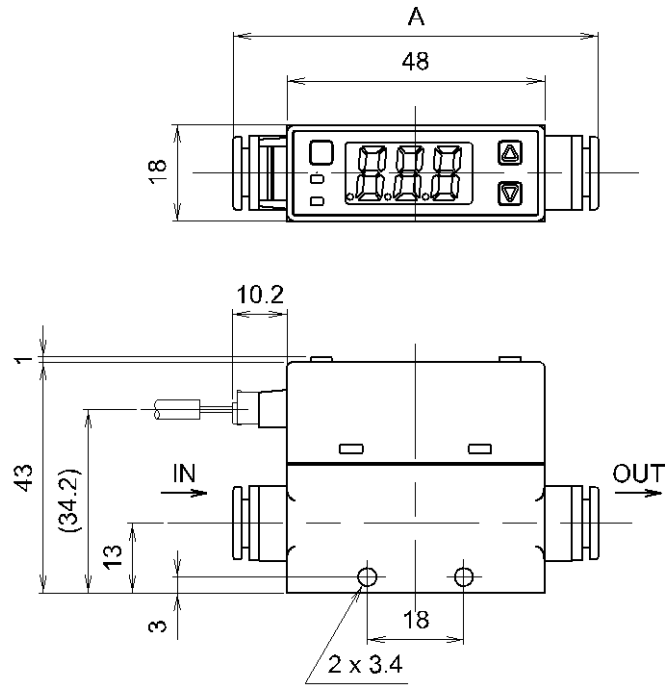
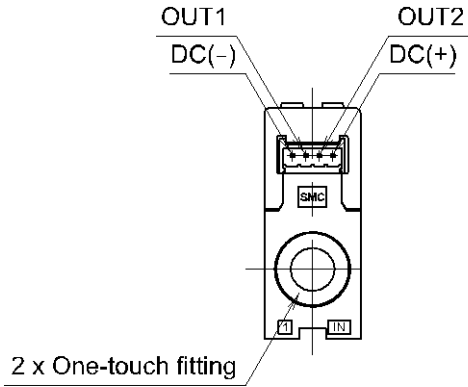

PFM7□□-C4L/C6L/C8L/N7L

Model	A
C4L	10.1
C6L	10.3
C8L	12
N7L	10.3

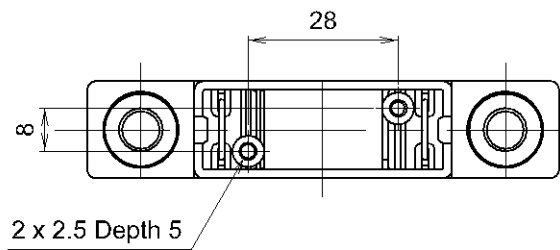
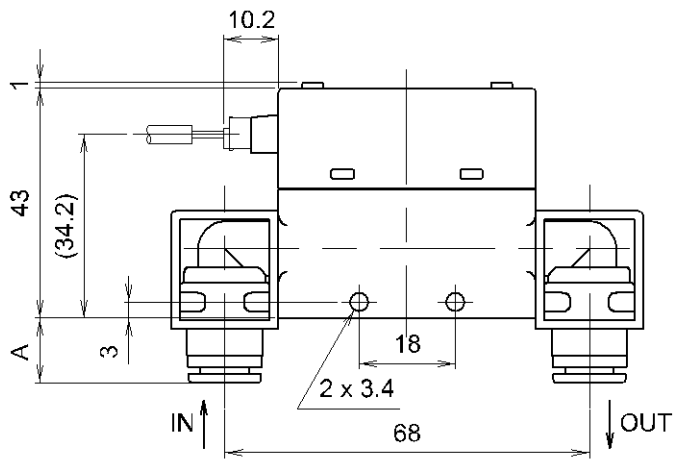
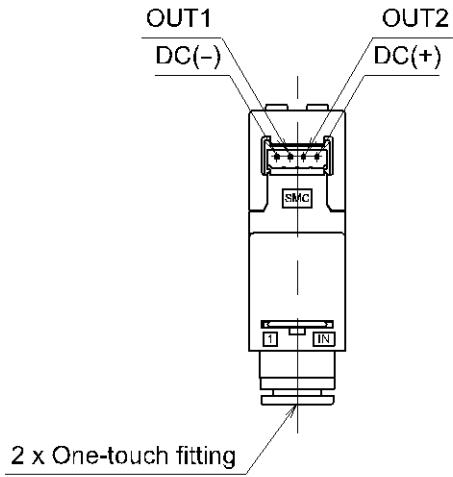
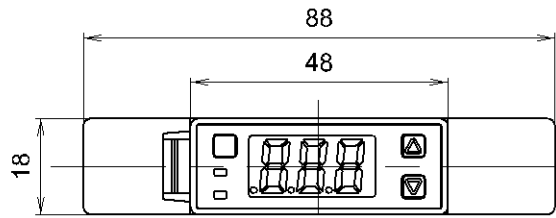

PFM7□□S-C4/C6/C8/N7

Model	A
C4	92.2
C6	92.6
C8	96
N7	92.6

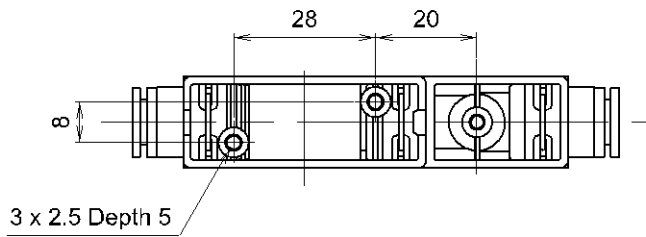
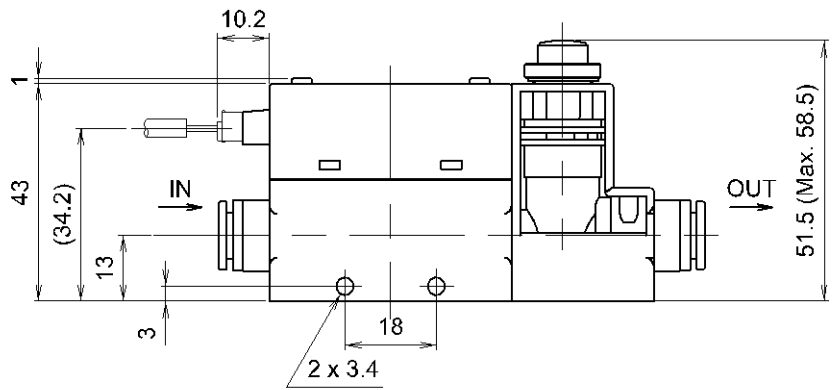
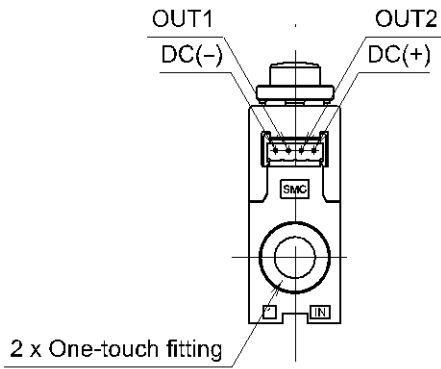
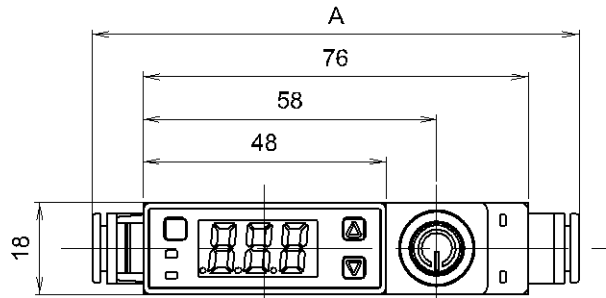

PFM7□□S-C4L/C6L/C8L/N7L

Model	A
C4L	10.1
C6L	10.3
C8L	12
N7L	10.3

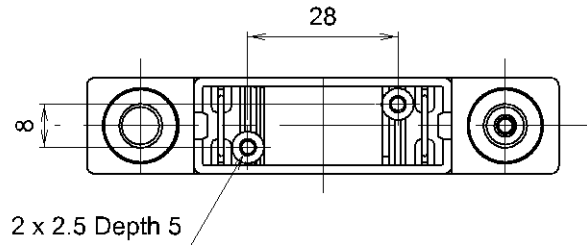
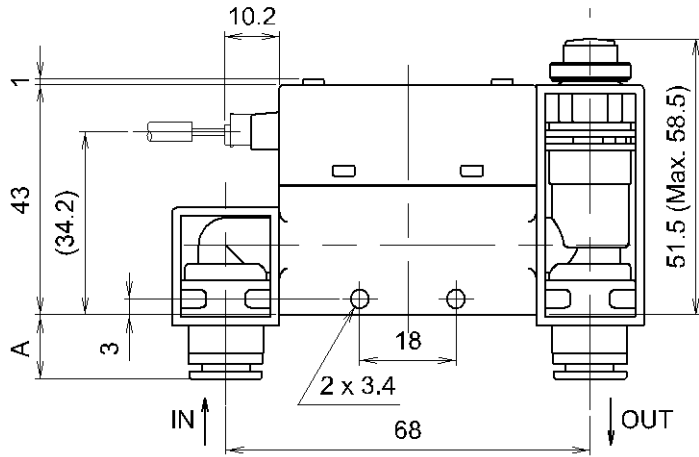
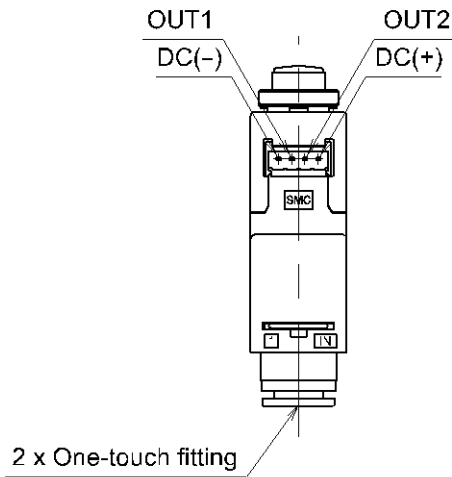
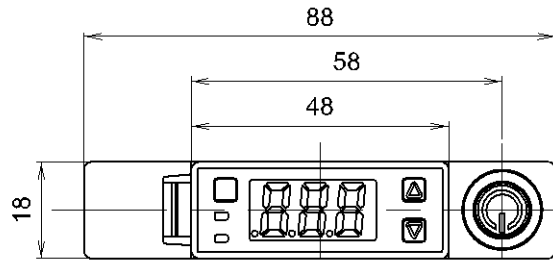

## Panel cut-out dimensions

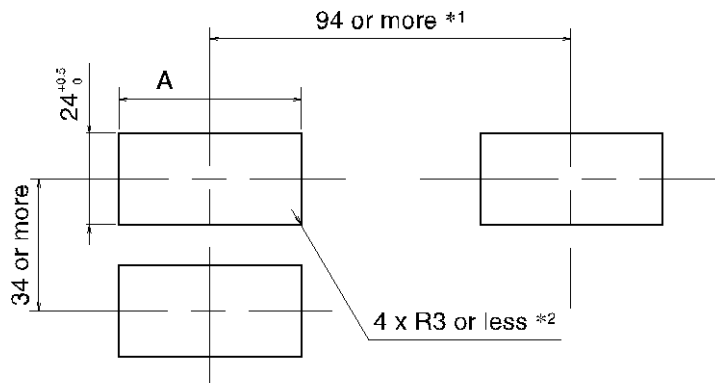

Flow adjustment valve	A
None	54 <sup>+0.5</sup> <sub>0</sub>
With flow adjustment valve	74 <sup>+0.5</sup> <sub>0</sub>

\*1: Piping entry direction: These are the minimum dimensions for bottom entry piping. If using straight entry piping, the material and tubing need to be taken into consideration when deciding panel cut-out spacing.

\*2: If a bend (R) is used, limit it to R3 or less.

\*3: Suitable for panel thickness of 1 to 3.2 mm.

## Bracket (ZS-33-M)

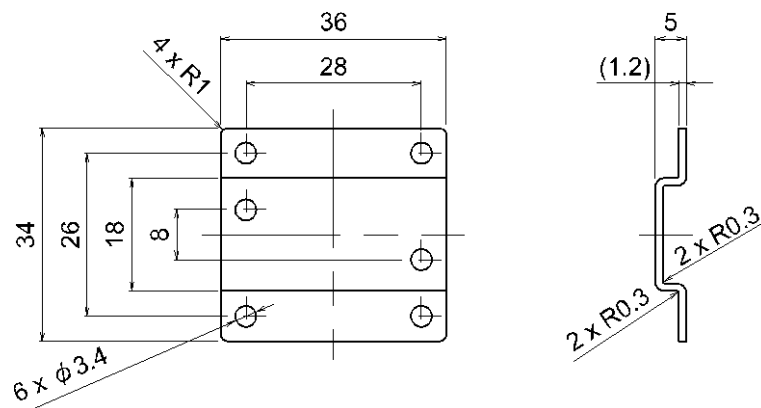

## Bracket (ZS-33-MS)

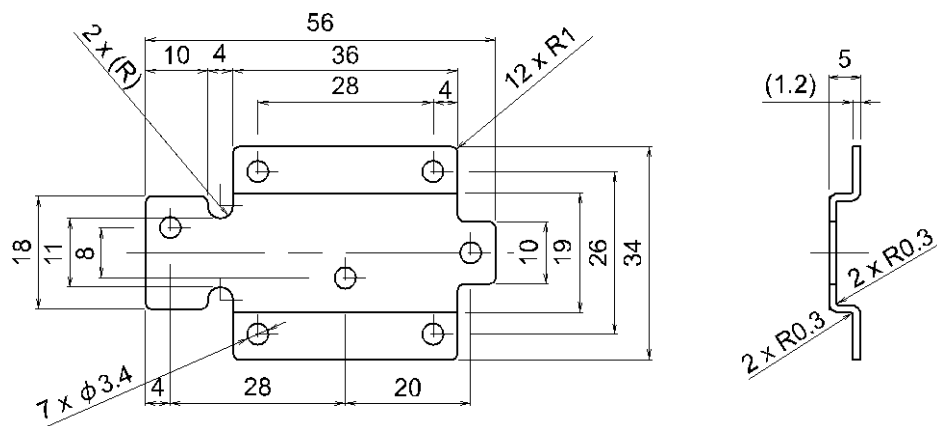



Lead wire and connector (ZS-33-D)

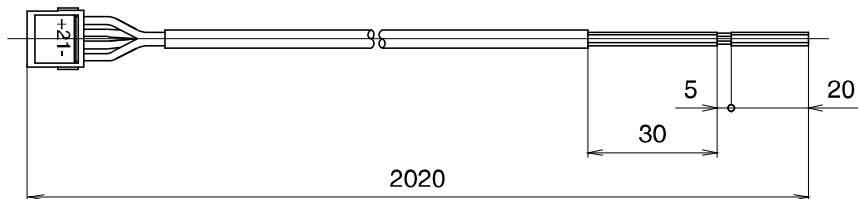

Connector cover (ZS-33-F)

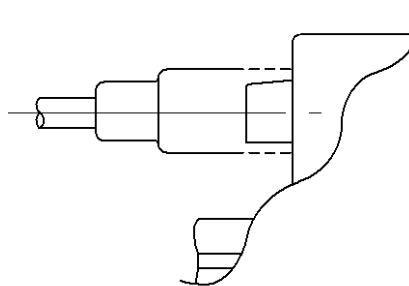
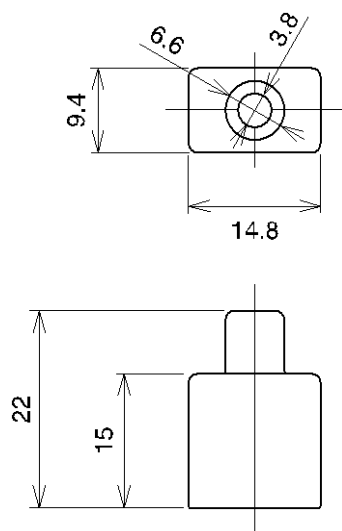

Attached the connector cover

# Made to Order

- Special combination of piping direction for IN side and OUT side ports

PFM7   -   -     - X693

Integrated display  
Piping direction  
\*: There is no symbol.

Piping direction combination

Symbol	Content
X693	IN side: Straight OUT side: Bottom entry
X694	IN side: Bottom entry OUT side: Straight

Refer to Model Indication and How to Order (page 10).

PFM7-C4/C6/C8/N7--X693

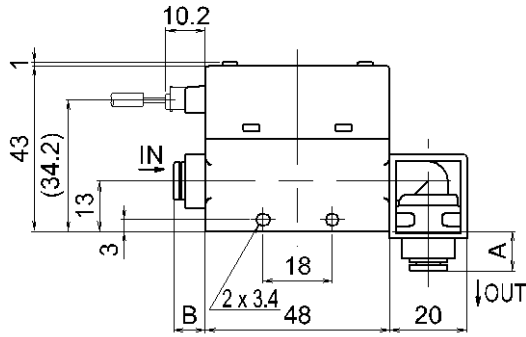

One-touch fitting		A	B
C4	φ4(5/32")	10.1	8.1
C6	φ6	10.3	8.3
C8	φ8(5/16")	12	10
N7	φ1/4	10.3	8.3

PFM7S-C4/C6/C8/N7--X693

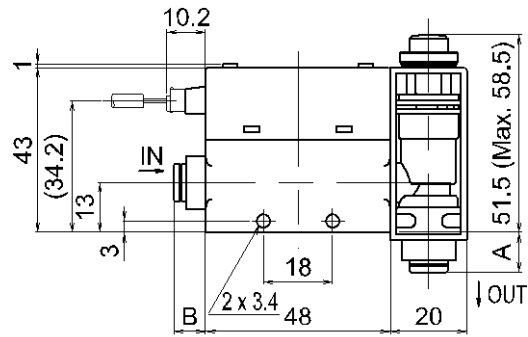

One-touch fitting		A	B
C4	φ4(5/32")	10.1	8.1
C6	φ6	10.3	8.3
C8	φ8(5/16")	12	10
N7	φ1/4	10.3	8.3

PFM7-01/02--X693

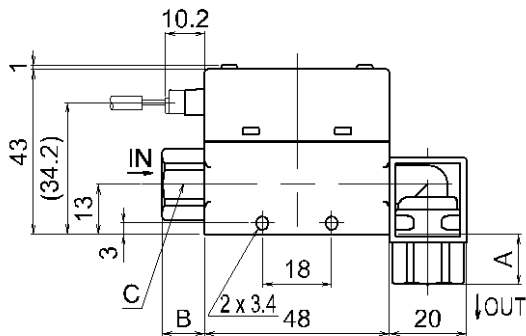

Connection port	A	B	C (Width across flat)
Rc1/8 · 1/4 NPT1/8 · 1/4 G1/8	13	11	17
G1/4	17	15	21

PFM7S-01/02--X693

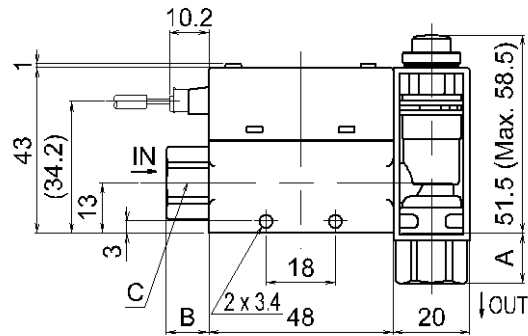

Connection port	A	B	C (Width across flat)
Rc1/8 · 1/4 NPT1/8 · 1/4 G1/8	13	11	17
G1/4	17	15	21

PFM7□□-C4/C6/C8/N7-□-X694

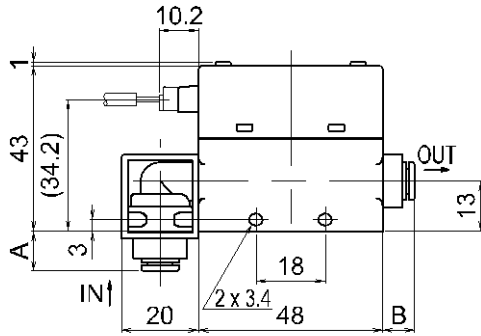

One-touch fitting		A	B
C4	φ4(5/32")	10.1	8.1
C6	φ6	10.3	8.3
C8	φ8(5/16")	12	10
N7	φ1/4	10.3	8.3

PFM7□□S-C4/C6/C8/N7-□-X694

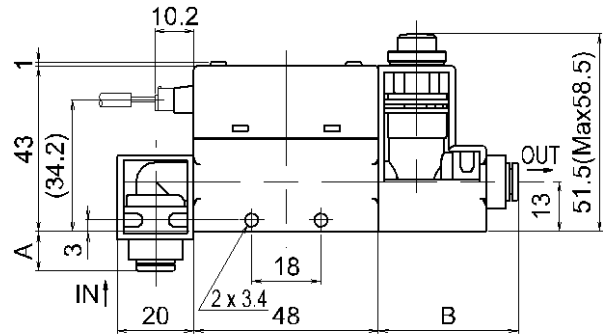

One-touch fitting		A	B
C4	φ4(5/32")	10.1	36.1
C6	φ6	10.3	36.3
C8	φ8(5/16")	12	37
N7	φ1/4	10.3	36.3

PFM7□□-□01/02-□-X694

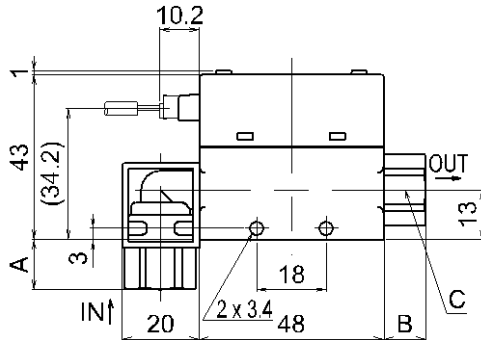

Connection port	A	B	C (Width across flat)
Rc1/8 · 1/4 NPT1/8 · 1/4 G1/8	13	11	17
G1/4	17	15	21

PFM7□□S-□01/02-□-X694

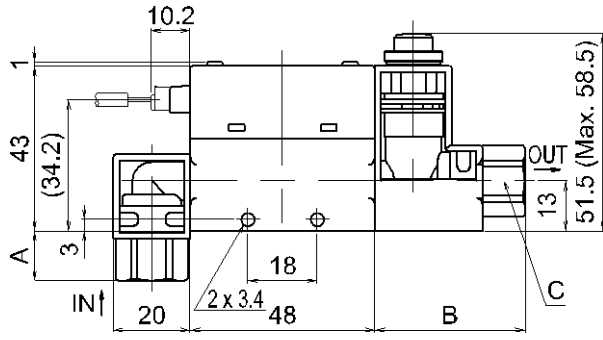

Connection port	A	B	C (Width across flat)
Rc1/8 · 1/4 NPT1/8 · 1/4 G1/8	13	39	17
G1/4	17	43	21

- For a mixture of Argon (Ar) and carbon dioxide (CO<sub>2</sub>)  
The mixture ratio can be selected from Ar:CO<sub>2</sub> = 92:8, 90:10, 80:20, 70:30 or 60:40.  
External dimensions are the same as standard.

PFM7   -   -  -    - X731

└─ Integrated display

Refer to Model Indication and How to Order (page 10).

### [F97] Gas mixture

Mixture gas can be selected.

The ratio of the gas mixture can be selected.

Label	Mixture ratio
928	Ar 92%, CO <sub>2</sub> 8%
91	Ar 90%, CO <sub>2</sub> 10%
82*1	Ar 80%, CO <sub>2</sub> 20%
73	Ar 70%, CO <sub>2</sub> 30%
64	Ar 60%, CO <sub>2</sub> 40%
oFF*2	No gas mixture selected

\*1: In the default setting, [8.2] is set.

\*2: If [oFF] is selected, the operating fluid setting of [F\_3] will apply.

### <Operation>

Press the or button in function selection mode to display [F97].

Press the button ↓

**Select gas mixture**  
Press the or button to select the mixture ratio.

Displayed in turn

0.95

↔

8.2

8.2

oFF

7.3

92.8

6.4

9.1

Press the button. ↓ Return to function selection mode.

[F97] Selection of Gas mixture completed

Details of rated flow range, display flow rate range, set flow rate range and maximum analogue output according to the gas mixture selected.

Model	Ratio		Rated flow range	Display flow range	Set flow range	Max. analogue output	
	Ar	CO <sub>2</sub>				Voltage V max.	Current I max.
PFM710	92%	8%	0.2 to 7.0 L/min	0.2 to 7.4 L/min	0 to 7.4 L/min	3.80 V	15.2 mA
	90%	10%					
	80%	20%					
	70%	30%					
	60%	40%					
PFM725	92%	8%	0.5 to 25.0 L/min	0.5 to 26.3 L/min	0 to 26.3 L/min	5.00 V	20.0 mA
	90%	10%	0.5 to 20.0 L/min	0.5 to 21.0 L/min	0 to 21.0 L/min	4.20 V	16.8 mA
	80%	20%					
	70%	30%					
	60%	40%					
PFM750	92%	8%	1.0 to 50.0 L/min	1.0 to 52.5 L/min	0 to 52.5 L/min	5.00 V	20.0 mA
	90%	10%	1.0 to 40.0 L/min	1.0 to 42.0 L/min	0 to 42 L/min	4.20 V	16.8 mA
	80%	20%					
	70%	30%					
	60%	40%					
PFM711	92%	8%	2 to 100 L/min	2 to 105 L/min	0 to 105 L/min	5.00 V	20.0 mA
	90%	10%	2 to 90 L/min	2 to 95 L/min	0 to 95 L/min	4.60 V	18.4 mA
	80%	20%					
	70%	30%					
	60%	40%					

Other specifications are the same as the standard product.

Output characteristic when gas mixture is selected

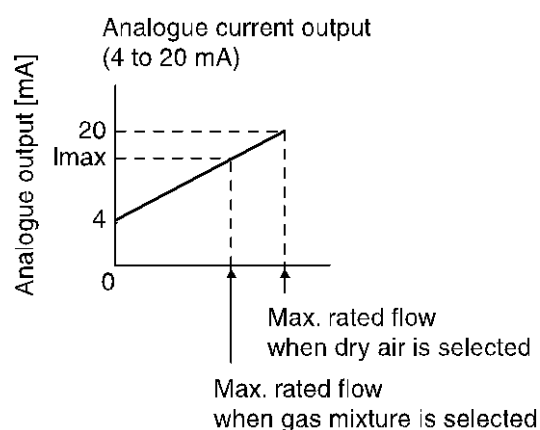
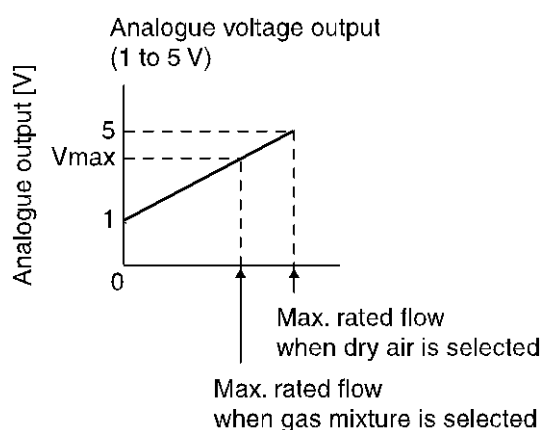

#### Revision history

A: Contents revised in several places.  
B: Contents revised in several places.  
C: Modified errors in text.  
D: Contents are added.  
E: Contents revised in several places.  
F: Contents revised in several places.  
[September 2016]  
G: Contents are added. [February 2017]  
H: Contents revised in several places.  
[August 2018]  
I: Contents are added. [May 2019]  
J: Contents revised in several places. [July 2022]

## SMC Corporation

4-14-1, Sotokanda, Chiyoda-ku, Tokyo 101-0021 JAPAN

Tel: + 81 3 5207 8249 Fax: +81 3 5298 5362

URL <https://www.smcworld.com>

---

Note: Specifications are subject to change without prior notice and any obligation on the part of the manufacturer.  
© 2011-2022 SMC Corporation All Rights Reserved

