



# Operation Manual

PRODUCT NAME

Digital Flow Switch  
(Integrated display type)

MODEL / Series / Product Number

*PF2M7##*

**SMC Corporation**

## Table of Contents

Safety Instructions	3
Model Indication and How to Order	11
Summary of Product parts	15
Definition and terminology	18
Mounting and Installation	21
Installation	21
Wiring	23
Outline of Settings	27
Flow Setting	28
Simple Setting Mode	29
Function Setting	30
Default setting	31
F0 Fluid/Unit criteria/Measurement unit setting	33
F1 Setting of OUT1	35
F2 Setting of OUT2	40
F3 Digital filter setting	44
F4 Auto-preset function setting	45
F10 Display mode setting	47
F11 Display resolution setting	48
F13 Setting for reverse display mode	49
F14 Zero cut-off setting	50
F20 External input setting	51
F22 Analogue output and analogue free span function setting	52
F30 Accumulated flow value hold setting	54
F80 Display OFF mode setting	55
F81 Security code	56
F90 Setting of all functions	57
F96 Check of external input signal	59
F98 Setting of output check	60
F99 Reset to the default settings	63

Other Settings	64
Maintenance	70
Forgotten the security code	70
IO-Link Specifications	71
Outline of IO-Link functions	71
Communication specifications	71
Process data	72
IO-Link parameter setting	76
Troubleshooting	84
Error indication	87
Specifications	89
Characteristics data	93
Dimensions	99



# Safety Instructions

These safety instructions are intended to prevent hazardous situations and/or equipment damage. These instructions indicate the level of potential hazard with the labels of "Caution", "Warning" or "Danger". They are all important notes for safety and must be followed in addition to International Standards (ISO/IEC)\*1), and other safety regulations.

\*1) ISO 4414: Pneumatic fluid power -- General rules relating to systems.

ISO 4413: Hydraulic fluid power -- General rules relating to systems.

IEC 60204-1: Safety of machinery -- Electrical equipment of machines. (Part 1: General requirements)

ISO 10218: Manipulating industrial robots -Safety.  
etc.



## Caution

**Caution** indicates a hazard with a low level of risk which, if not avoided, could result in minor or moderate injury.



## Warning

**Warning** indicates a hazard with a medium level of risk which, if not avoided, could result in death or serious injury.



## Danger

**Danger** indicates a hazard with a high level of risk which, if not avoided, will result in death or serious injury.

## Warning

### 1. The compatibility of the product is the responsibility of the person who designs the equipment or decides its specifications.

Since the product specified here is used under various operating conditions, its compatibility with specific equipment must be decided by the person who designs the equipment or decides its specifications based on necessary analysis and test results.

The expected performance and safety assurance of the equipment will be the responsibility of the person who has determined its compatibility with the product.

This person should also continuously review all specifications of the product referring to its latest catalog information, with a view to giving due consideration to any possibility of equipment failure when configuring the equipment.

### 2. Only personnel with appropriate training should operate machinery and equipment.

The product specified here may become unsafe if handled incorrectly.

The assembly, operation and maintenance of machines or equipment including our products must be performed by an operator who is appropriately trained and experienced.

### 3. Do not service or attempt to remove product and machinery/equipment until safety is confirmed.

1. The inspection and maintenance of machinery/equipment should only be performed after measures to prevent falling or runaway of the driven objects have been confirmed.

2. When the product is to be removed, confirm that the safety measures as mentioned above are implemented and the power from any appropriate source is cut, and read and understand the specific product precautions of all relevant products carefully.

3. Before machinery/equipment is restarted, take measures to prevent unexpected operation and malfunction.

### 4. Contact SMC beforehand and take special consideration of safety measures if the product is to be used in any of the following conditions.

1. Conditions and environments outside of the given specifications, or use outdoors or in a place exposed to direct sunlight.

2. Installation on equipment in conjunction with atomic energy, railways, air navigation, space, shipping, vehicles, military, medical treatment, combustion and recreation, or equipment in contact with food and beverages, emergency stop circuits, clutch and brake circuits in press applications, safety equipment or other applications unsuitable for the standard specifications described in the product catalog.

3. An application which could have negative effects on people, property, or animals requiring special safety analysis.

4. Use in an interlock circuit, which requires the provision of double interlock for possible failure by using a mechanical protective function, and periodical checks to confirm proper operation.



# Safety Instructions

## Caution

### **1. The product is provided for use in manufacturing industries.**

The product herein described is basically provided for peaceful use in manufacturing industries. If considering using the product in other industries, consult SMC beforehand and exchange specifications or a contract if necessary.  
If anything is unclear, contact your nearest sales branch.

## **Limited warranty and Disclaimer/Compliance Requirements**

The product used is subject to the following "Limited warranty and Disclaimer" and "Compliance Requirements".

Read and accept them before using the product.

### **Limited warranty and Disclaimer**

#### **1. The warranty period of the product is 1 year in service or 1.5 years after the product is delivered, whichever is first.\*2)**

Also, the product may have specified durability, running distance or replacement parts. Please consult your nearest sales branch.

#### **2. For any failure or damage reported within the warranty period which is clearly our responsibility, a replacement product or necessary parts will be provided.**

This limited warranty applies only to our product independently, and not to any other damage incurred due to the failure of the product.

#### **3. Prior to using SMC products, please read and understand the warranty terms and disclaimers noted in the specified catalog for the particular products.**

**\*2) Vacuum pads are excluded from this 1 year warranty.**

A vacuum pad is a consumable part, so it is warranted for a year after it is delivered.

Also, even within the warranty period, the wear of a product due to the use of the vacuum pad or failure due to the deterioration of rubber material are not covered by the limited warranty.

### **Compliance Requirements**

#### **1. The use of SMC products with production equipment for the manufacture of weapons of mass destruction (WMD) or any other weapon is strictly prohibited.**

#### **2. The exports of SMC products or technology from one country to another are governed by the relevant security laws and regulation of the countries involved in the transaction. Prior to the shipment of a SMC product to another country, assure that all local rules governing that export are known and followed.**

## Caution

### **SMC products are not intended for use as instruments for legal metrology.**

Products that SMC manufactures or sells are not measurement instruments that are qualified by pattern approval tests relating to the measurement laws of each country.

Therefore, SMC products cannot be used for business or certification ordained by the measurement laws of each country.

## Operator

- ◆ This operation manual is intended for those who have knowledge of machinery using pneumatic equipment, and have sufficient knowledge of assembly, operation and maintenance of such equipment. Only those persons are allowed to perform assembly, operation and maintenance.
- ◆ Read and understand this operation manual carefully before assembling, operating or providing maintenance to the product.

### ■ Safety Instructions

#### **Warning**

- Do not disassemble, modify (including changing the printed circuit board) or repair.  
An injury or failure can result.
- Do not operate the product outside of the specifications.  
Do not use for flammable or harmful fluids.  
Fire, malfunction, or damage to the product can result.  
Verify the specifications before use.
- Do not operate in an atmosphere containing flammable, explosive or corrosive gas.  
Otherwise, fire, explosion or corrosion may occur.  
This product is not designed to be explosion proof.
- Do not use the product for flammable fluid.  
A fire or explosion can result.  
Only dry air, N<sub>2</sub>, CO<sub>2</sub> and Ar are applicable.
- Do not use the product in a place where static electricity is a problem.  
Otherwise it can cause failure or malfunction of the system.
- If using the product in an interlocking circuit:
  - Provide a double interlocking system, for example a mechanical system
  - Check the product regularly for proper operationOtherwise malfunction can result, causing an accident.
- The following instructions must be followed during maintenance :
  - Turn off the power supply
  - Stop the air supply, exhaust the residual pressure and verify that the air is released before performing maintenance workOtherwise an injury can result.

## Caution

- Do not touch the terminals and connectors while the power is on.  
Otherwise electric shock, malfunction or damage to the product can result.
- After maintenance is complete, perform appropriate functional inspections and leak tests.  
Stop operation if the equipment does not function properly or there is a leakage of fluid.  
When leakage occurs from parts other than the piping, the product might be faulty.  
Disconnect the power supply and stop the fluid supply.  
Do not apply fluid under leaking conditions.  
Safety cannot be assured in the case of unexpected malfunction.

### ■ NOTE

- Follow the instructions given below when designing, selecting and handling the product.
  - The instructions on design and selection (installation, wiring, environment, adjustment, operation, maintenance, etc.) described below must also be followed.
  - \*Product specifications
    - The direct current power supply used should be UL approved as follows.  
Circuit (Class 2) of maximum 30 Vrms (42.4 V peak) or less, with UL1310 Class 2 power supply unit or UL1585 Class 2 transformer.
    - The product is a UL approved product only if it has a  mark on the body.
    - Use the specified voltage.  
Otherwise failure or malfunction can result.  
Insufficient supply voltage may not drive a load due to a voltage drop inside the product.  
Verify the operating voltage of the load before use.
    - Do not exceed the specified maximum allowable load.  
Otherwise it can cause damage or shorten the lifetime of the product.
    - Data stored by the product is not deleted, even if the power supply is cut off.  
(Writing time: 3700000 cycles)
    - Applicable operating fluid depends on the product.  
Check the details of the specifications before using.
    - Before designing piping confirm the pressure loss at the sensor from the pressure loss graph.  
Confirm pressure loss of the sensor from the characteristics data.
    - For the details of compressed air quality, refer to ISO 8573-1, 1.1.2 to 1.6.2.
    - Use the specified measurement flow rate and operating pressure.  
Otherwise it can cause damage to the product or inability to measure correctly.
    - Reserve a space for maintenance.  
Allow sufficient space for maintenance when designing the system.

●Product handling

\*Installation

- Do not apply excessive stress to the product when it is mounted with a panel mount.  
Otherwise damage to the product and disconnection from the panel can result.
- Ensure that the FG terminal is connected to ground when using a commercially available switch-mode power supply.
- Do not drop, hit or apply excessive shock to the product.  
Otherwise damage to the internal parts can result, causing malfunction.
- Do not pull the lead wire forcefully, or lift the product by the lead wire. (Tensile force 49N or less)  
Hold the product body when handling, to prevent damage, failure or malfunction
- For piping of the product, hold the piping with a wrench on the metal part of the product.  
Holding other parts of the product with a wrench may damage the product.
- Any dust left in the piping should be flushed out by air blow before connecting the piping to the product.  
Otherwise damage or malfunction can result.
- Refer to the flow direction of the fluid indicated on the product for installation and piping.  
Retention of air can cause inability to measure accurately.
- Do not mount the body with the bottom facing upwards.  
Retention of air can cause inability to measure accurately.
- Do not insert metal wires or other foreign matter into the piping port.  
This can damage the sensor causing failure or malfunction.
- Never mount a product in a location that will be used as a foothold.  
The product may be damaged if excessive force is applied by stepping or climbing onto it.
- If there is a risk of foreign matter entering the fluid, install and pipe a filter or the mist separator at the inlet to avoid failure and malfunction.  
Otherwise damage or malfunction can result.  
And it can cause inability to measure accurately.  
Refer to the figure below for the recommended pneumatic circuit.
- If the fluid flow on the IN side (entry side) of the product is unstable, correct measurement will not be possible.  
If a valve is used on the IN side (entry side) of the product, the fluid may be unstable due to the change of the effective area, and there may be an error in the flow measurement results.

Recommended pneumatic circuit example

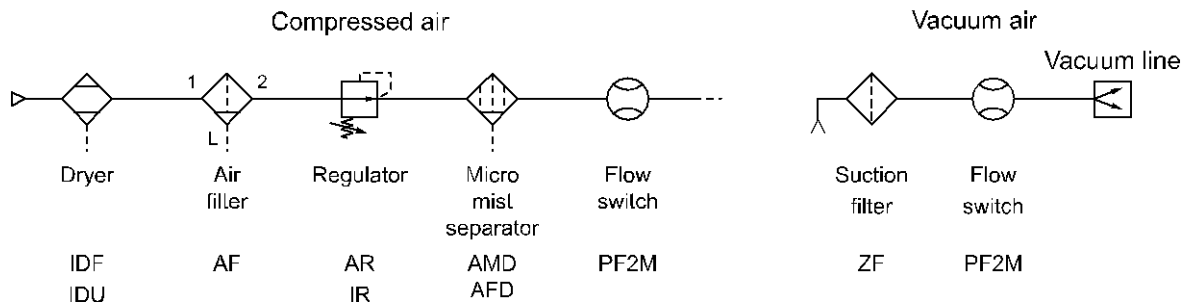



#### \*Wiring

- Do not pull the lead wires.

In particular, never lift a product equipped with fitting and piping by holding the lead wires.

Otherwise damage to the internal parts can result, causing malfunction or disconnection of the connector.

- Avoid repeatedly bending or stretching the lead wire, or placing heavy loads on it

Repeated bending stress or tensile stress can cause damage to the sheath, or breakage of the wires.

If the lead wire can move, fix it near the body of the product.

The recommended bend radius of the lead wire is 6 times the outside diameter of the sheath, or 33 times the outside diameter of the wire insulation material, whichever is larger.

Replace any damaged lead wire with a new one.

- Wire correctly.

Incorrect wiring can damage the product.

- Do not perform wiring while the power is on.

Otherwise damage to the internal parts can result, causing malfunction.

- Do not route wires and cables together with power or high voltage cables.

Otherwise the product can malfunction due to interference or noise and surge voltage from power and high voltage cables.

- Confirm proper insulation of wiring.

Poor insulation (interference from another circuit, poor insulation between terminals, etc.) can lead to excess voltage or current being applied to the product, causing damage.

- Keep wiring as short as possible to prevent interference from electromagnetic noise and surge voltage.

Do not use a cable longer than 30 m.

When using it as an IO-Link device, do not use a cable longer than 20 m.

Wire the DC (-) line (blue) as close as possible to the power supply.

- When analogue output is used, install a noise filter (line noise filter, ferrite element, etc.) between the switch-mode power supply and this product.

#### \*Environment

- Do not use the product in area that is exposed to corrosive gases, chemicals, sea water, water or steam.  
Otherwise failure or malfunction can result.
- Do not use in a place where the product could be splashed by oil or chemicals.  
If the product is to be used in an environment containing oils or chemicals such as coolant or cleaning solvent, even for a short time, it may be adversely affected (damage, malfunction, or hardening of the lead wires)
- Do not use in an area where electrical surges are generated.  
If there is equipment generates large electrical surges (solenoid type lifter, high frequency induction furnace, motor, etc.) close to the product, damage or failure of the internal circuit may occur. Take measures against the surge sources, and prevent the wires from coming into close contact.
- Do not use a load which generates a surge voltage.  
When a surge-generating load such as a relay or solenoid is driven directly, use a product with a built-in surge absorbing element.
- The product is CE/UKCA marked, but not immune to lightning strikes. Take measures against lightning strikes in the system.
- Do not use the product in areas that are exposed to vibration or impact.  
Otherwise failure or malfunction can result.
- Do not use the product in the presence of a magnetic field.  
This may lead to the malfunction of the product.
- Prevent foreign matter such as wire debris from entering the product.  
Otherwise failure or malfunction can result.
- Do not use the product in areas subject to large temperature cycle.  
Heating/cooling cycles other than ordinary changes in temperature can adversely affect the internal structure of the product
- Do not expose the product to direct sunlight.  
If using in a location directly exposed to sunlight, use a suitable protective cover.  
Otherwise failure or malfunction can result.
- Keep within the operating fluid temperature and operation temperatures range.  
The operating fluid temperature and operating temperature range is 0 to 50 °C.  
Operation below the minimum temperature limit may cause damage or operation failure due to frozen moisture in the fluid or air.  
Protection against freezing is necessary.  
An air dryer is recommended for elimination of drainage and water.  
Avoid sudden temperature changes even within the specified temperature range.
- Do not operate close to a heat source, or in a location exposed to radiant heat.  
Otherwise malfunction can result.
- The temperature between products rises when sticking is installed, and there is a possibility to influence the performance of the product.

#### \*Adjustment and Operation

- Connect load before turning on the power.
- Do not short-circuit the load.  
Although an error is displayed when the product load is short circuited, excess current may cause damage to the product.
- Do not press the setting buttons with a sharp pointed object.  
This may damage the setting buttons.
- Supply the power when there is no flow.
- The output is off for 3 seconds after power is supplied.
- Use settings suitable for the operating conditions.  
Incorrect settings can cause operational failure.  
(Refer to page 28 "Flow setting".)
- During the initial setting and any subsequent flow rate setting, the product will switch the output according to the existing settings until the changes are complete.  
Confirm the output has no adverse effect on machinery and equipment before setting.  
Stop the control system before setting if necessary.
- Do not touch the LCD during operation.  
The display can vary due to static electricity.

#### \*Maintenance

- Perform regular maintenance and inspections.  
There is a risk of unexpected malfunction of components due to the malfunction of equipment and machinery.
- Turn off the power supply, stop the supplied air, exhaust the residual pressure and verify the release of air before performing maintenance.  
There is a risk of unexpected malfunction.
- Perform drainage regularly.  
If condensate enters the outside, it can cause operating failure of pneumatic equipment.
- Do not use solvents such as benzene, thinner etc. to clean the product.  
They could damage the surface of the body and erase the markings on the body.  
Use a soft cloth to remove stains.  
For heavy stains, use a cloth lightly dampened with diluted neutral detergent, then wipe up any residue with a dry cloth.

#### \*Other

- If there is a restrictor fitted, vibration may cause the flow adjustment valve to rotate and change the flow rate.

# Model Indication and How to Order

PF2M 7 □ □ - □ - □ □ - □ □ □

Integrated display type

Rated flow range (Flow range)

Symbol	Content
01	0.01 to 1 L/min
02	0.02 to 2 L/min
05	0.05 to 5 L/min
10	0.1 to 10 L/min
25	0.3 to 25 L/min
50	0.5 to 50 L/min
11	1 to 100 L/min
21	2 to 200 L/min

Flow adjustment valve/Piping direction

Symbol	Flow adjustment valve	Piping direction	Rated flow range								
			1	2	5	10	25	50	100	200	
Nil	None	Straight	●	●	●	●	●	●	●	●	●
S	Yes	Straight	-	-	●	●	●	●	●	●	●
L	None	Rear piping	●	●	●	●	●	●	●	●	●
W	Yes	Rear piping	-	-	●	●	●	●	●	●	●

\*: 1 L/min, 2 L/min types with flow adjustment valves is not available.

Port size

Symbol	Port size	Rated flow range							
		1	2	5	10	25	50	100	200
01	Rc1/8	●	●	●	●	●	●	-	-
N1	NPT1/8	●	●	●	●	●	●	-	-
F1	G1/8	●	●	●	●	●	●	-	-
02	Rc1/4	-	-	-	-	-	-	●	●
N2	NPT1/4	-	-	-	-	-	-	●	●
F2	G1/4	-	-	-	-	-	-	●	●
C4	φ4	●	●	●	●	-	-	-	-
C6	φ6	●	●	●	●	●	●	-	-
C8	φ8	-	-	-	-	-	-	●	●
N7	φ1/4	-	-	-	●	●	●	●	●

Output specification

Symbol	OUT1	OUT2
A	NPN	NPN
B	PNP	PNP
C	NPN	Analogue 1 to 5 V ⇔ Analogue 0 to 10 V <sup>*1</sup>
D	NPN	Analogue 4 to 20 mA
E	PNP	Analogue 1 to 5 V ⇔ Analogue 0 to 10 V <sup>*1</sup>
F	PNP	Analogue 4 to 20 mA

\*1: 1 to 5 V or 0 to 10 V can be selected by pressing the button.  
The default setting is 1 to 5 V.

Calibration certificate<sup>\*6</sup>

Symbol	Content
Nil	Without calibration certificate
A	With calibration certificate

\*6: Made to order.  
Certificate in both Japanese and English.

Option 2

Symbol	Content
Nil	Without bracket
R	Bracket (without flow adjustment valve) <sup>*5</sup>
S	Bracket (with flow adjustment valve) <sup>*5</sup>
T	Panel mount adapter (without flow adjustment valve) <sup>*5</sup>
V	Panel mount adapter (with flow adjustment valve) <sup>*5</sup>

\*5: Each accessory is not assembled with the product, but shipped together.

Unit specification

Symbol	Content
Nil	Unit selection function <sup>*3</sup>
M	SI unit only <sup>*4</sup>

\*3: Since the unit for Japan is fixed to SI due to new measurement law, this option is for overseas.  
Unit can be changed Instantaneous flow: L/min ⇔ cfm  
Accumulated flow: L ⇔ ft<sup>3</sup>

\*4: Fixed unit Instantaneous flow: L/min  
Accumulated flow: L

Option 1

Symbol	Content
Nil	With lead wire with connector (2 m) <sup>*2</sup>
W	With lead wire with connector (2 m) + Rubber cover for connector <sup>*2</sup>
N	Without lead wire with connector

\*2: Interchangeable with the existing PFM series.

## IO-Link compatible product

PF2M 7   -  -   -    -

Integrated display type

Rated flow range (Flow range)

Symbol	Content
01	0.01 to 1 L/min
02	0.02 to 2 L/min
05	0.05 to 5 L/min
10	0.1 to 10 L/min
25	0.3 to 25 L/min
50	0.5 to 50 L/min
11	1 to 100 L/min
21	2 to 200 L/min

Flow adjustment valve/Piping direction

Symbol	Flow adjustment valve	Piping direction	Rated flow range								
			1	2	5	10	25	50	100	200	
Nil	None	Straight	●	●	●	●	●	●	●	●	●
S	Yes	Straight	-	-	●	●	●	●	●	●	●
L	None	Rear piping	●	●	●	●	●	●	●	●	●
W	Yes	Rear piping	-	-	●	●	●	●	●	●	●

\*: 1 L/min, 2 L/min types with flow adjustment valves is not available.

Port size

Symbol	Port size	Rated flow range								
		1	2	5	10	25	50	100	200	
01	Rc1/8	●	●	●	●	●	●	●	-	-
N1	NPT1/8	●	●	●	●	●	●	●	-	-
F1	G1/8	●	●	●	●	●	●	●	-	-
02	Rc1/4	-	-	-	-	-	-	-	●	●
N2	NPT1/4	-	-	-	-	-	-	-	●	●
F2	G1/4	-	-	-	-	-	-	-	●	●
C4	φ4	●	●	●	●	●	●	●	-	-
C6	φ6	●	●	●	●	●	●	●	-	-
C8	φ8	-	-	-	-	-	-	-	●	●
N7	φ 1/4	-	-	-	●	●	●	●	●	●

Output specification

Symbol	OUT1	OUT2
L	IO-Link/NPN/PNP	-
L2	IO-Link/NPN/PNP	NPN/PNP/Exterior input
L3	IO-Link/NPN/PNP	Analogue 1 to 5 V ⇔ Analogue 0 to 10 V <sup>*1</sup>
L4	IO-Link/NPN/PNP	Analogue 4 to 20 mA

\*1: 1 to 5 V or 0 to 10 V can be selected by pressing the button.  
The default setting is 1 to 5 V.

Made to order

Symbol	Content
X731	For Argon (Ar) and carbon dioxide (CO2) mixtures

\*: For details, refer to page 14.

Calibration certificate<sup>\*6</sup>

Symbol	Content
Nil	Without calibration certificate
A	With calibration certificate

\*6: Made to order.

Certificate in both Japanese and English.

Option 2

Symbol	Content
Nil	Without bracket
R	Bracket (without flow adjustment valve) <sup>*5</sup>
S	Bracket (with flow adjustment valve) <sup>*5</sup>
T	Panel mount adapter (without flow adjustment valve) <sup>*5</sup>
V	Panel mount adapter (with flow adjustment valve) <sup>*5</sup>

\*5: Each accessory is not assembled with the product, but shipped together.

Unit specification

Symbol	Content
Nil	Unit selection function <sup>*3</sup>
M	SI unit only <sup>*4</sup>

\*3: Since the unit for Japan is fixed to SI due to new measurement law, this option is for overseas.

Unit can be changed Instantaneous flow: L/min ⇔ cfm  
Accumulated flow: L ⇔ ft<sup>3</sup>

\*4: Fixed unit Instantaneous flow: L/min  
Accumulated flow: L

Option 1

Symbol	Content
Nil	With lead wire with connector (2 m) <sup>*2</sup>
W	With lead wire with connector (2 m) + Rubber cover for connector <sup>*2</sup>
N	Without lead wire with connector
Q	With M12 conversion lead wire (0.1 m) <sup>*2</sup>

\*2: Interchangeable with the existing PFM series.

### Option1

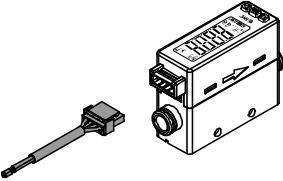
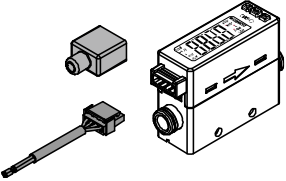
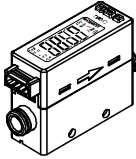
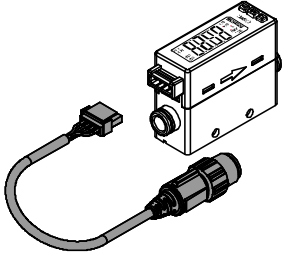
			IO-Link compatible product
Nil	W	N	Q
with lead wire and connector (2 m)	with lead wire and connector (2 m) + Connector cover (silicone rubber)	without lead wire	M12 conversion lead wire
			

### Option2

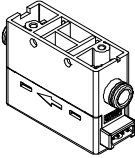
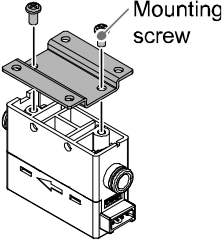
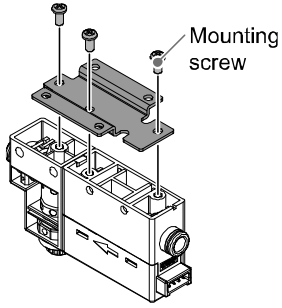
Nil	R	S
without bracket	with bracket (without flow adjustment valve)	with bracket (with flow adjustment valve)
		
		Not suitable for bottom entry piping type.

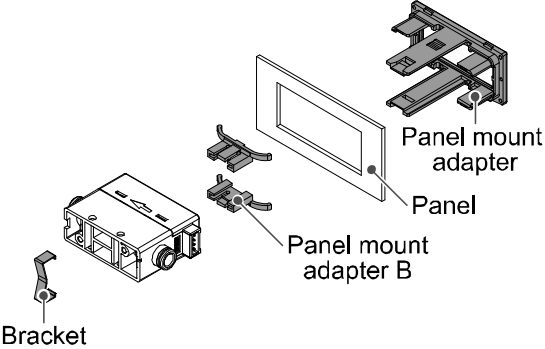
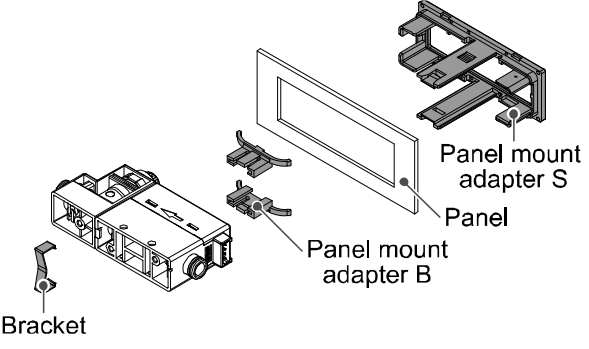
T	V
with panel mount adapter (without flow adjustment valve)	with panel mount adapter (with flow adjustment valve)
	

\*: Each accessory is not assembled with the product, but shipped together.

### Made to Order

Symbol	Content
X731	For Argon (Ar) and carbon dioxide (CO <sub>2</sub> ) mixtures Mixture ratio (Ar: CO <sub>2</sub> ) 92: 8, 90: 10, 80: 20, 70: 30, 60: 40

### Accessories/Part number

If an accessory is required separately, order using the following part numbers.

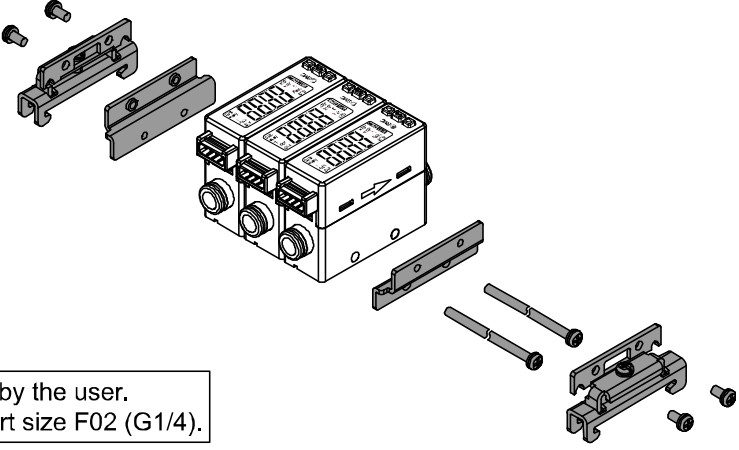
Part number	Description	Remarks												
ZS-33-D	Lead wire and connector	Length: 2 m												
ZS-33-DM	M12 conversion lead wire	Length: 0.1 m												
ZS-33-F	Connector cover (silicone rubber) 													
ZS-33-2J	Panel mount adapter (without flow adjustment valve)													
ZS-33-2JS	Panel mount adapter (with flow adjustment valve)													
ZS-33-M	Bracket (without flow adjustment valve)	Mounting screw 2 pcs.												
ZS-33-MS	Bracket (with flow adjustment valve)	Mounting screw 3 pcs.												
ZS-33-R#	DIN rail mounting parts <div style="display: flex; align-items: center; margin-top: 10px;"> <div style="margin-right: 20px;"> <p>ZS-33-R <input type="checkbox"/></p> <p>Number of stations</p> <table border="1" style="border-collapse: collapse; text-align: center;"> <thead> <tr> <th>Symbol</th> <th>No. of stations</th> </tr> </thead> <tbody> <tr> <td>1</td> <td>1 station</td> </tr> <tr> <td>2</td> <td>2 stations</td> </tr> <tr> <td>3</td> <td>3 stations</td> </tr> <tr> <td>4</td> <td>4 stations</td> </tr> <tr> <td>5</td> <td>5 stations</td> </tr> </tbody> </table> </div> <div style="flex-grow: 1;">  </div> </div> <div style="margin-top: 20px; border: 1px solid black; padding: 5px; width: fit-content;"> <ul style="list-style-type: none"> <li>• DIN rail should be prepared by the user.</li> <li>• DIN rail is not suitable for port size F02 (G1/4).</li> </ul> </div>	Symbol	No. of stations	1	1 station	2	2 stations	3	3 stations	4	4 stations	5	5 stations	
Symbol	No. of stations													
1	1 station													
2	2 stations													
3	3 stations													
4	4 stations													
5	5 stations													

## Summary of Product parts

### Body

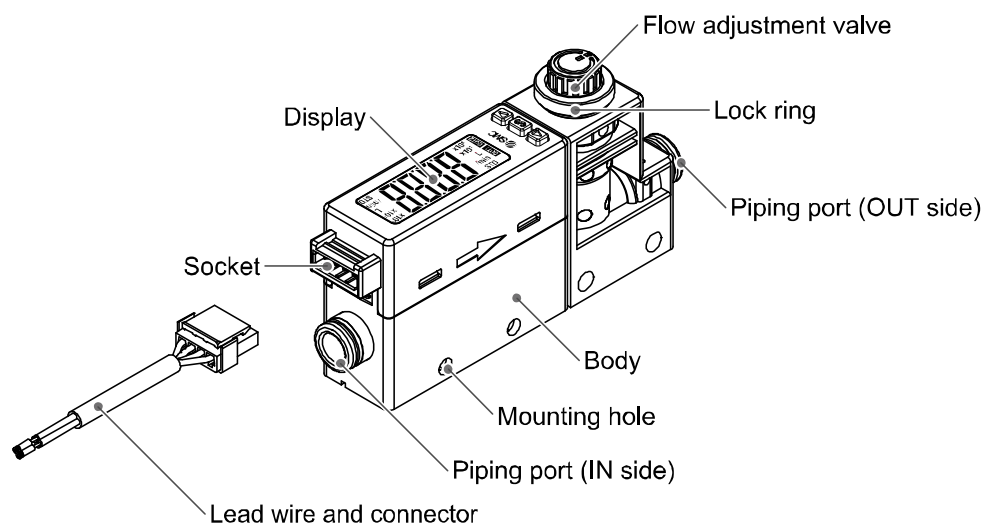

Item	Description
Socket	Socket for electrical connections.
Piping port	Connected to the fluid inlet at IN side and to the fluid outlet at OUT side.
Flow adjustment valve *	Orifice mechanism to adjust the flow.
Lock ring *	Used to lock the flow adjustment valve.
Mounting hole	Used to mount the product on a DIN rail or directly to a panel.
Body	The body of the product.
Lead wire and connector	Lead wire to supply power and transmit output signals.

\*: The table shows the specifications when a flow adjusting valve is included.



## Display

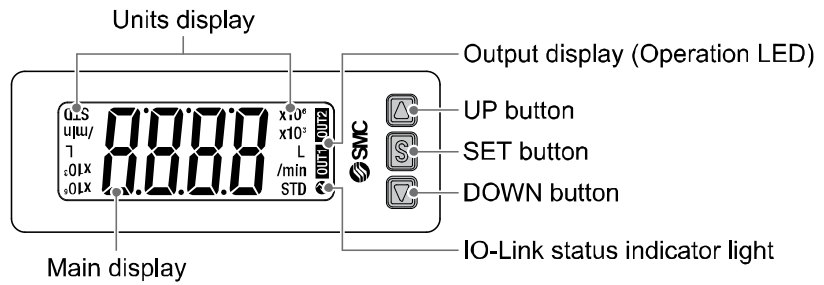

Item	Description
UP button *	Selects the mode or increases the ON/OFF set value. Press this button to change to the peak display mode.
DOWN button *	Selects the mode or decreases the ON/OFF set value. Press this button to change to the bottom display mode.
Main display	Displays the flow value, setting mode, and error indication. Four display modes can be selected: display always in red or green, or display changing from green to red, or red to green, according to the output status (OUT1).
SET button	Press this button to change to another mode and to set a value.
Output display (Operation LED)	Displays the output status of OUT1 and OUT2. OUT1: LED is ON (Orange) when the output is ON. OUT2: LED is ON (Orange) when the output is ON. When the accumulated pulse output mode is selected, the output display is OFF.
Units display	Arbitrary units is ON based on the flow display setting (instantaneous or accumulated flow)
IO-Link status indicator light	LED is ON when OUT1 is used in IO-Link mode. (LED is OFF in SIO mode)

\*: If the reversed display has been selected, the UP and DOWN button function will be reversed.

•IO-Link indicator light operation and display

Communication with master	IO-Link status indicator light	Status			Display *1	Content
Yes	 *1	IO-Link mode	Correct	Operate	oPE	Normal communication status (Reading of measurement value)
				Start up	St r t	When communication starts up.
				Preoperate	P r E	
No	(Flashing) *1	IO-Link mode	Abnormal	Version does not match	Er 15	Version of master and IO-Link does not match. Mismatch because master version is 1.0.
				Communication shut-off	St r t P r E oPE	Correct communication was not received for 1 second or more.
	OFF	SIO mode			S IO	General switch output

\*1: In IO-Link mode, the IO-Link indicator is ON or flashing.

\*2: "LoC" is displayed when the data storage lock is enabled. (Except for version mismatch or when in SIO mode)  
The display colour can be set to red or green.

## ■ Definition and terminology

	Terms	Meaning
A	Accumulated flow	The total amount of fluid that has passed through the device. If an instantaneous flow of 10 L/min continues for 5 minutes, the accumulated flow will be $10 \times 5 = 50$ L.
	Accumulated pulse output	A type of output where a pulse is generated every time a predefined accumulated flow passes. It is possible to calculate the total accumulated flow by counting the pulses.
	Accumulated-value hold time	A function to store the cumulative flow value in the product's internal memory at certain time intervals. Reads the memory data when power is supplied. Accumulation of data begins with the value read at the moment power is supplied. The time interval for memorizing can be selected from 2 or 5 minutes.
	Analogue output	Outputs a value proportional to the flow rate. When the analogue output is in the range 1 to 5 V, it will vary between 1 to 5 V according to the rate of flow. The same for analogue output of 0 to 10 V or 4 to 20 mA.
	Auto-preset	This function will automatically calculate and set the optimum flow rate based on the actual operating condition when hysteresis mode is selected.
C	Chattering	The problem of the switch output turning ON and OFF repeatedly around the set value at high frequency due to the effect of pulsation.
D	Delay time	The setting time from when the flow applied to the flow switch reaches the set value, to when the ON-OFF output actually begins working. Delay time setting can prevent the output from chattering.
	digit (Min. setting unit)	Shows how precisely the flow can be displayed or set by the digital flow switch. When 1 digit = 1 L/min, the flow is displayed in increments of 1 L/min, e.g., 1, 2, 3, ..., 99, 100.
	Digital filter	Function to add digital filtering to the fluctuation of flow value. Smooth the fluctuation of displayed value for sharp start up or fall of the flow. When the function is valid, digital filtering is reflected to the ON/OFF of the switch output. Output chattering or flicker in the measurement mode display can be reduced by setting the digital filter. The response time indicates when the set value is 90% in relation to the step input.
	Display flow range	The range of measured values that can be displayed for a product with a digital display.
E	Error displayed	The code number displayed, identifying the error detected by the self-diagnosis function of the pressure switch. Refer to "Error indication" on page 87 for details of the errors.
	Error output	Switches the switch output to ON/OFF when an error is displayed. Refer to "List of output modes" on page 39 for operating conditions. Refer to "Error indication" on page 87 for details of the errors.
F	F.S. (Full span, Full scale)	Stands for "full span" or "full scale", and indicates varied display value and analogue output range at rated value. For example, when analogue output is 1 to 5 V, $F.S. = 5[V] - 1[V] = 4[V]$ , (ref. $1\%F.S. = 4[V] \times 1\% = 0.04[V]$ )
	Fluid temperature range	Range of fluid temperature that can be measured by the product.

	Terms	Meaning
H	Hysteresis	The difference between ON and OFF points used to prevent chattering. Hysteresis can be effective in avoiding the effects of pulsation.
	Hysteresis mode	Mode where the switch output will turn ON when the flow is greater than the set value, and will turn off when the flow falls below (set value – hysteresis value).
I	Instantaneous flow	The flow passing per unit of time. If it is 10 L/min, there is a flow of 10 L passing through the device in 1 minute.
	Insulation resistance	Insulation resistance of the product. The resistance between the electrical circuit and the case.
	Internal voltage drop	The voltage drop across the product (and therefore not applied to the load), when the switch output is ON. The voltage drop will vary with load current, and ideally should be 0 V.
K	Key-lock function	This function prevents the set value from being changed by mishandling.
M	Maximum applied voltage	The maximum voltage that can be connected to the output of an NPN device.
	Maximum load current	The maximum current that can flow to the output (output line) of the switch output.
	Max. (Min.) load impedance	The maximum (minimum) load (resistance value and impedance) which can be connected to the output (output wire)of the analogue current output.
	Measurement mode	Operating condition in which flow is being detected and displayed, and the switch function is working.
	Min. setting unit	Shows how precisely the flow can be displayed or set by the digital flow switch. When 1 digit = 1 L/min, the flow is displayed in increments of 1 L/min, e.g., 1, 2, 3, ..., 99, 100.
O	Operating humidity range	Humidity range in which the product can operate.
	Operating temp. range	Ambient temperature range in which product is operable.
	Output impedance	The resistance value of a component between the voltage output element and the analogue voltage output. It is indicated as a resistance value which is converted in accordance with the condition in which resistance is directly connected to the voltage output element. There may be an error in the output voltage depending on this output impedance and the input impedance of customers' equipment. (example: If the flow switch with output impedance of 1 kΩ is connected to the A/D converter to detect the analogue output of 5 V, the detected voltage by the A/D converter becomes $5(V) \times 1(M\Omega) / (1(k\Omega) + 1(M\Omega)) \doteq 4.995(V)$ , and there is an error of approximate 0.005 V).

	Terms	Meaning
P	Part in contact with fluid	A part that comes into physical contact with the fluid.
	Pressure characteristics	Indicates the change in the display value and analogue output when fluid pressure changes.
	Proof pressure	Burst pressure at which the product is electrically or mechanically damaged.
R	Rated flow range	The flow range within which the product will meet all published specifications.
	Rated pressure range	The pressure range that satisfies the specifications.
	Repeatability	Reproducibility of the display or analogue output value, when the measured quantity is repeatedly increased and decreased.
	Ripple	Indicates pulsation.
S	Set flow range	The range of ON/OFF threshold values that can be set for those products with a switch output.
	Switch output	Output type that has only 2 conditions, ON or OFF. When in the ON condition an indicator light will show, and any connected load will be powered. When in the OFF condition, there will be no indicator light and no power supplied to the load.
T	Temperature characteristics	Indicates the change in the display value and analogue output caused by ambient temperature changes.
U	Unit selection function	A function to select display units other than the international unit (SI unit) specified in the new Japanese measurement law. Flow can only be displayed by SI units in Japan.
W	Window comparator mode	An operating mode in which the switch output is turned on and off depending on whether the flow is inside or outside the range of two set values.
	Withstand voltage	A measure of the product's resistance to a voltage applied between the electrical circuit and case. Durability in withstanding voltage. The product may be damaged if a voltage over this value is applied. (The withstand voltage is not the supply voltage used to power the product.)
Z	Zero-clear function	This function to adjust the displayed flow to zero.

## Mounting and Installation

### ■ Installation

- Refer to the flow direction of the fluid indication on the product label for installation and piping.

#### Panel mounting

- Insert panel mount adapter B (supplied as an accessory) into section A of panel mount adapter.  
Push panel mount adapter B from behind until the display is fixed onto the panel.  
The pin of bracket engages the notched part of panel adapter section C to fix the display.
- The switch can be mounted on a panel with a thickness of 1 to 3.2 mm.
- Refer to the dimension drawing (page 99) for panel cut-out dimensions.

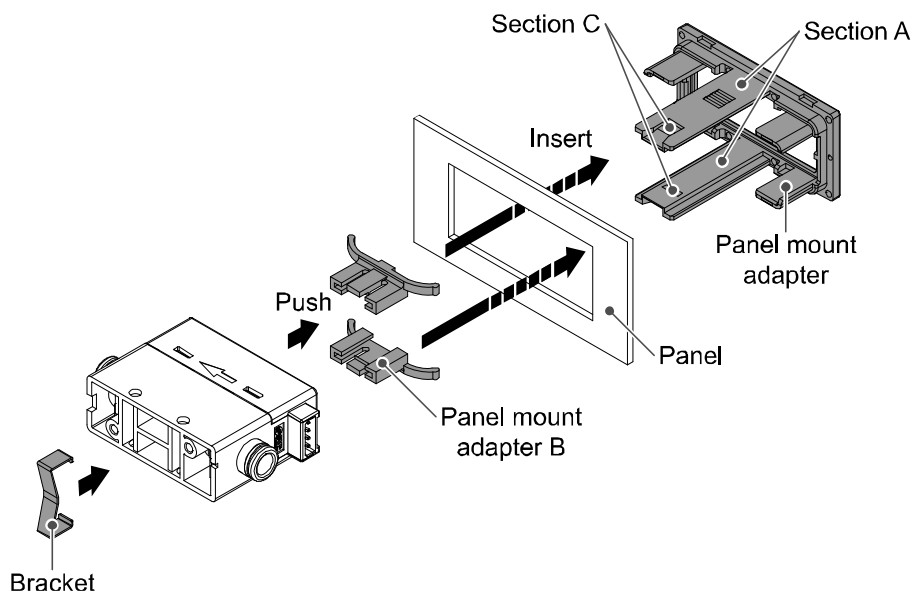

## Bracket mounting

- Mount the bracket using the mounting screws supplied.
- The required tightening torque is  $0.42 \pm 0.04$  N•m.

Without flow adjustment valve  
(using ZS-33-M)

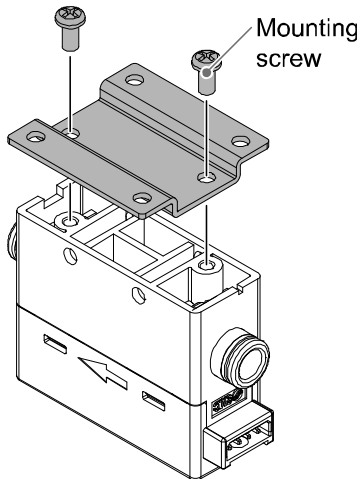

With flow adjustment valve  
(using ZS-33-MS)

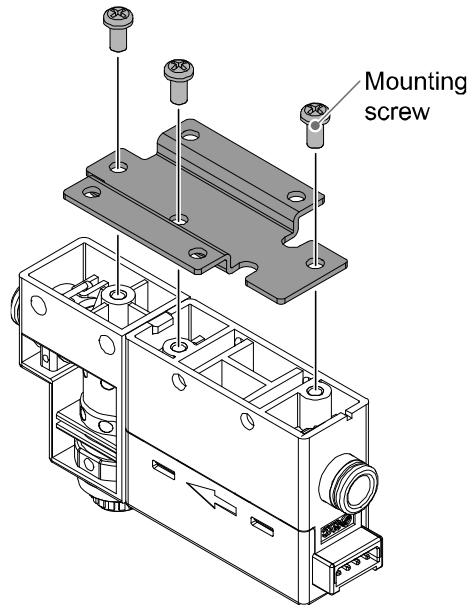

- Install the product (with bracket) using the M3 screws (4 pcs.).
- Bracket thickness is approximately 1.2 mm.
- Refer to the dimension drawing of the bracket (page 99) for mounting hole dimensions.

## DIN rail mounting (using ZS-33-R#)

- Mount the DIN rail mounting parts using DIN rail mounting screws and joint screws supplied.
- The required tightening torque of the DIN rail mounting screws and joint screws is  $0.4 \pm 0.05$  N•m.

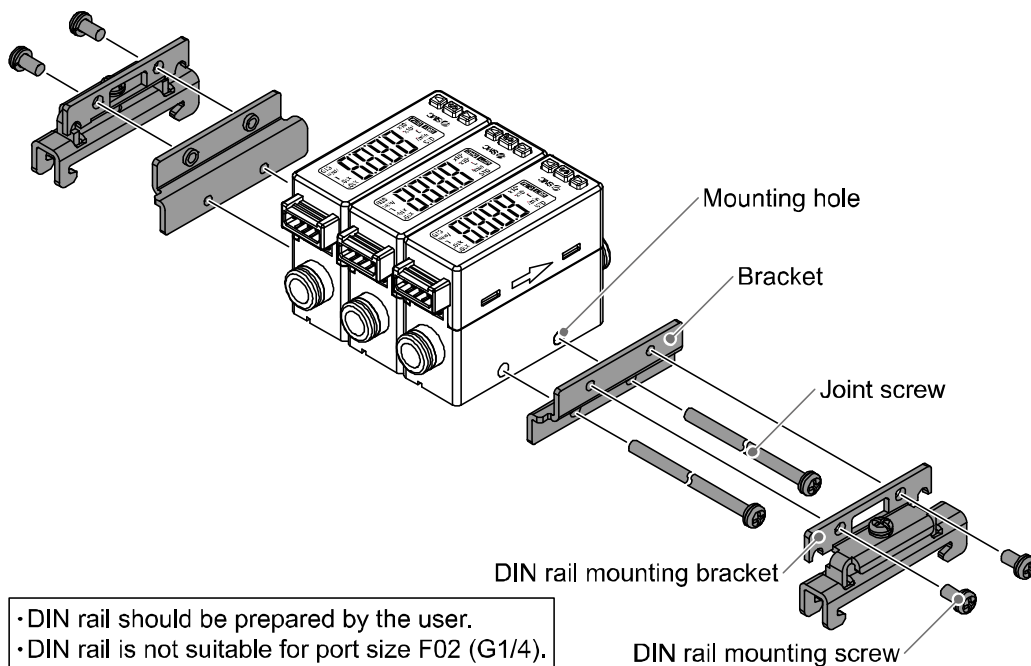

## ■Wiring

### Wiring of connector

- Connections should only be made with the power supply turned off.
- Use separate routes for the product wiring and any power or high voltage wiring. Otherwise, malfunction may result due to noise.
- Ensure that the FG terminal is connected to ground when using a commercially available switch-mode power supply. When a switch-mode power supply is connected to the product, switching noise will be superimposed and the product specification can no longer be met. This can be prevented by inserting a noise filter, such as a line noise filter and ferrite core, between the switch-mode power supply and the product, or by using a series power supply instead of a switch-mode power supply.

### Connecting/Disconnecting

- When mounting the connector, insert it straight into the socket, holding the lever and connector body, and push the connector until the lever hooks into the housing, and locks.
- When removing the connector, press down the lever to release the hook from the housing and pull the connector straight out.

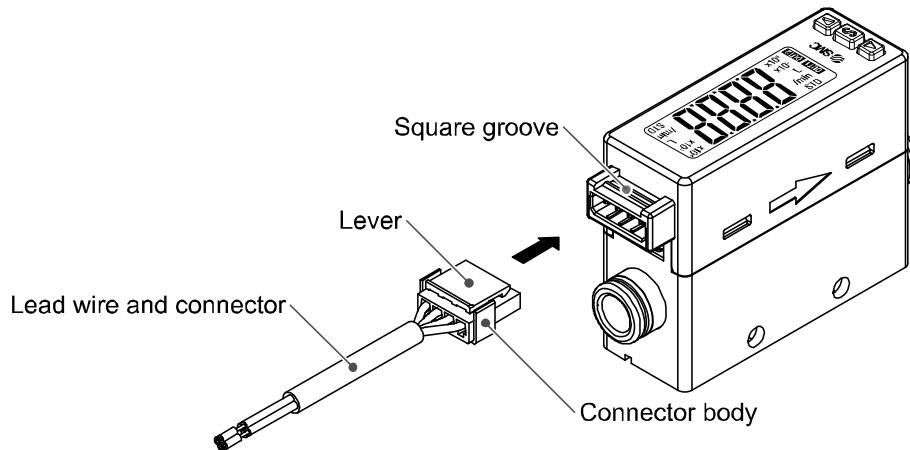



## Connector pin numbers (on the lead wire)

### •Lead wire and connector (ZS-33-D)

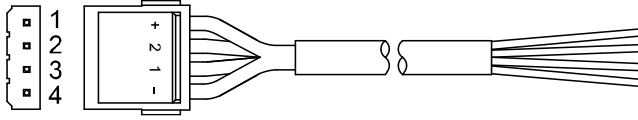

No.	Name	Lead wire colour	Function
1	DC(+)	Brown	12 to 24 VDC
2	OUT2	White	Switch output 2/Analogue output
3	OUT1	Black	Switch output 1
4	DC(-)	Blue	0 V

### •M12 conversion lead wire (ZS-33-DM)

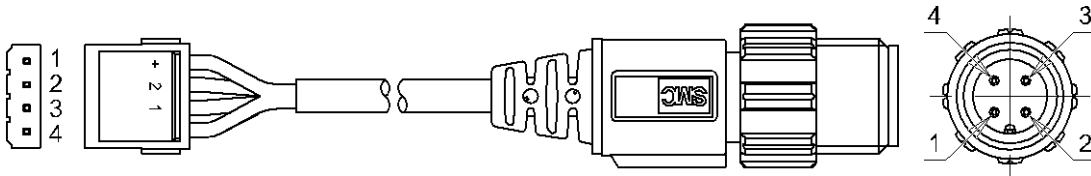

#### Used as switch output device

No.	Name	Lead wire colour	Function
1	DC(+)	Brown	12 to 24 VDC
2	N.C./OUT2	White	Not connected/Switch output 2 (SIO)
3	DC(-)	Blue	0 V
4	OUT1	Black	Switch output 1

#### Used as IO-Link device

No.	Name	Lead wire colour	Function
1	L+	Brown	18 to 30 VDC
2	N.C./OUT2	White	Not connected/Switch output 2 (SIO)
3	L-	Blue	0 V
4	C/Q	Black	Communication data (IO-Link)/Switch output 1 (SIO)

## Internal circuit and wiring example

### PF2M7##-#-L#-### (NPN)

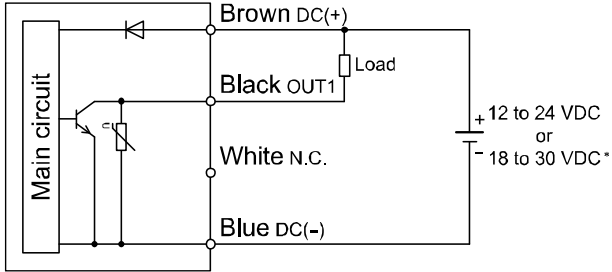

Maximum applied voltage: 28 V  
 Maximum load current: 80 mA  
 Internal voltage drop: 1.5 V or less

### PF2M7##-#-L#-### (PNP)

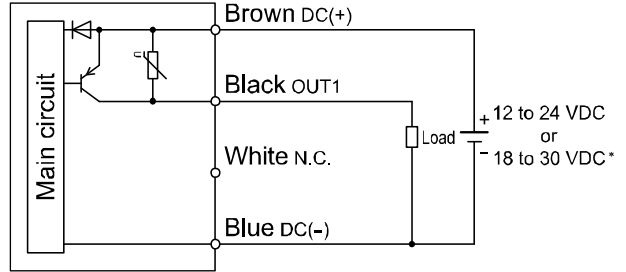

Maximum load current: 80 mA  
 Internal voltage drop: 1.5 V or less

### PF2M7##-#-A#-###

#### PF2M7##-#-L2#-### (NPN)

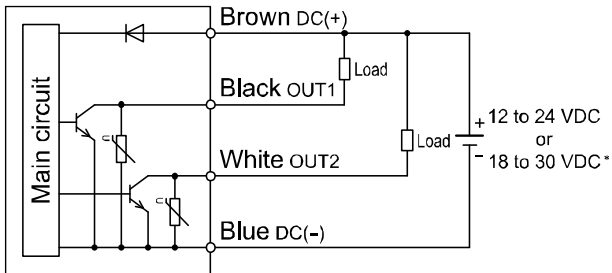

Maximum applied voltage: 28 V  
 Maximum load current: 80 mA  
 Internal voltage drop: 1.0 V or less  
 (For output specification of  
 PF2M7##-#-A)  
 1.5 V or less  
 (For output specification of  
 PF2M7##-#-L2)

### PF2M7##-#-B#-###

#### PF2M7##-##-L2 (PNP)

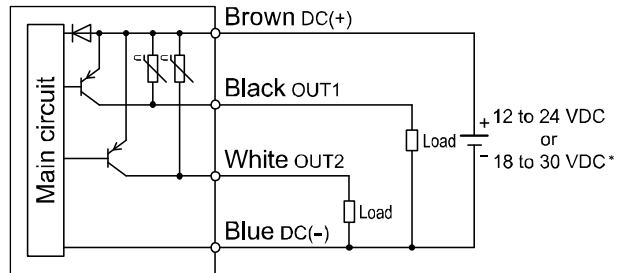

Maximum load current: 80 mA  
 Internal voltage drop: 1.5 V or less

### PF2M7##-#-L2#-### (NPN + external input)

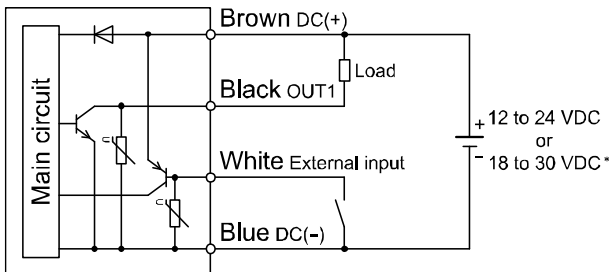

Maximum applied voltage: 28 V  
 Maximum load current: 80 mA  
 Internal voltage drop: 1.5 V or less

### PF2M7##-#-L2#-### (PNP + external input)

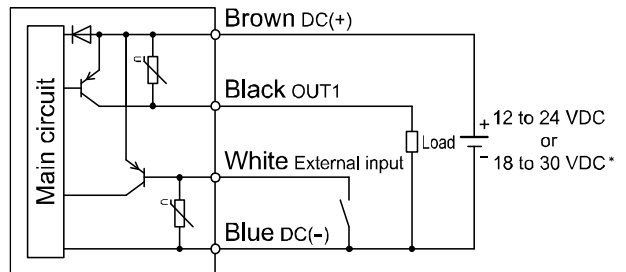

Maximum load current: 80 mA  
 Internal voltage drop: 1.5 V or less

**PF2M7##-#-C/D#-###**

**PF2M7##-#-L3/L4#-### (NPN)**

- L3: NPN + Analogue voltage output type
- L4: NPN + Analogue current output type

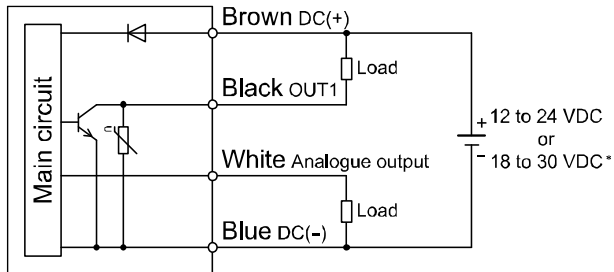

Maximum applied voltage: 28 V  
 Maximum load current: 80 mA  
 Internal voltage drop: 1.5 V or less

- L3: Analogue output: 1 to 5 V, 0 to 10 V (selectable)  
 Output impedance: 1 k $\Omega$
- L4: Analogue output: 4 to 20 mA  
 Load impedance: 50 to 600  $\Omega$

\*: IO-Link compatible product

**PF2M7##-#-E/F#-###**

**PF2M7##-#-L3/L4#-### (PNP)**

- L3: PNP + Analogue voltage output type
- L4: PNP + Analogue current output type

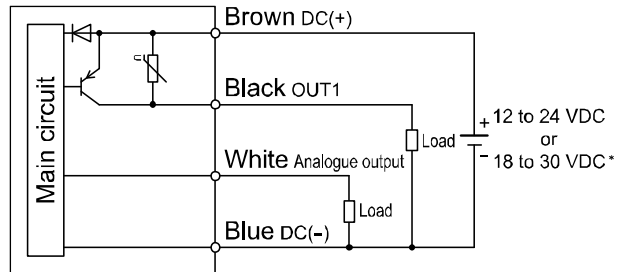

Maximum load current: 80 mA  
 Internal voltage drop: 1.5 V or less

- L3: Analogue output: 1 to 5 V, 0 to 10 V (selectable)  
 Output impedance: 1 k $\Omega$
- L4: Analogue output: 4 to 20 mA  
 Load impedance: 50 to 600  $\Omega$

**Used as IO-Link device**

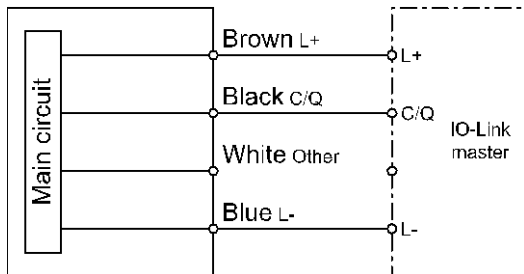

## Outline of Settings

**Power is supplied.**



The product code is displayed for approximately 3 sec. after power is supplied.  
Then, measurement mode will be displayed.

\*: After moving on to the measurement mode, the switch operation will start.



### [Measurement mode]

Measurement mode is the condition where the flow is detected and displayed, and the switch function is operating.  
This is the basic mode; other modes should be selected for set-point changes and other function settings.

#### Measurement mode screen

Current flow rate value  
or peak/bottom value

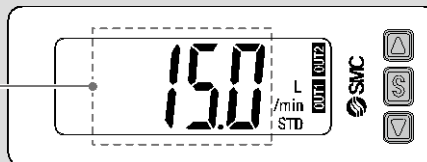

Press the SET button  
once.



Press the SET button  
between 2 to 5 seconds.



Press the SET button for  
5 seconds or longer.

#### Change of Set Flow and Hysteresis

(Simple setting mode)  
(Refer to page 29)

#### Change the Function Settings

(Function selection mode)  
(Refer to page 30)

#### Other Settings •Key-lock

(Refer to page 66)

\*: The outputs will continue to operate during setting.

\*: Simple setting mode and function selection mode settings are reflected each other.

# Flow Setting

## Switch operation

When the flow exceeds the set value, the switch will turn ON.

When the flow falls below the set value by the amount of hysteresis or more, the switch will turn OFF.

The default setting is to turn on the flow switch when the flow reaches the center of the upper limit of the rated flow range.

If this condition, shown to the below, is acceptable, then keep these settings.

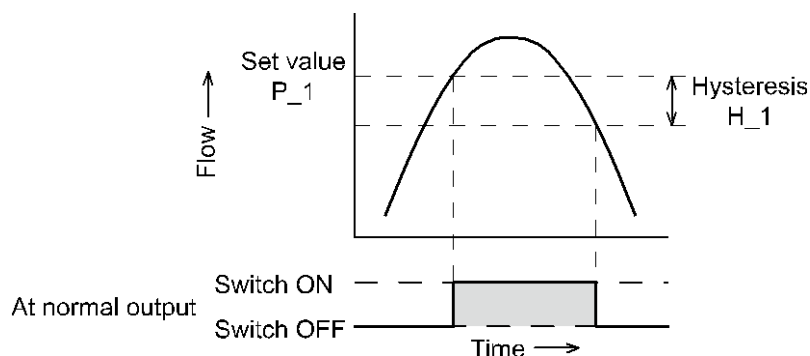

### ●PF2M701

Item	Default Settings
[P_1] Set value of OUT1	0.5 L/min
[H_1] Hysteresis of OUT1	0.05 L/min
[P_2] Set value of OUT2 *	0.5 L/min
[H_2] Hysteresis of OUT2 *	0.05 L/min

### ●PF2M702

Item	Default Settings
[P_1] Set value of OUT1	1.0 L/min
[H_1] Hysteresis of OUT1	0.1 L/min
[P_2] Set value of OUT2 *	1.0 L/min
[H_2] Hysteresis of OUT2 *	0.1 L/min

### ●PF2M705

Item	Default Settings
[P_1] Set value of OUT1	2.5 L/min
[H_1] Hysteresis of OUT1	0.25 L/min
[P_2] Set value of OUT2 *	2.5 L/min
[H_2] Hysteresis of OUT2 *	0.25 L/min

### ●PF2M710

Item	Default Settings
[P_1] Set value of OUT1	5.00 L/min
[H_1] Hysteresis of OUT1	0.50 L/min
[P_2] Set value of OUT2 *	5.00 L/min
[H_2] Hysteresis of OUT2 *	0.50 L/min

### ●PF2M725

Item	Default Settings
[P_1] Set value of OUT1	12.5 L/min
[H_1] Hysteresis of OUT1	1.3 L/min
[P_2] Set value of OUT2 *	12.5 L/min
[H_2] Hysteresis of OUT2 *	1.3 L/min

### ●PF2M750

Item	Default Settings
[P_1] Set value of OUT1	25.0 L/min
[H_1] Hysteresis of OUT1	2.5 L/min
[P_2] Set value of OUT2 *	25.0 L/min
[H_2] Hysteresis of OUT2 *	2.5 L/min

### ●PF2M711

Item	Default Settings
[P_1] Set value of OUT1	50.0 L/min
[H_1] Hysteresis of OUT1	5.0 L/min
[P_2] Set value of OUT2 *	50.0 L/min
[H_2] Hysteresis of OUT2 *	5.0 L/min

### ●PF2M721

Item	Default Settings
[P_1] Set value of OUT1	100 L/min
[H_1] Hysteresis of OUT1	10 L/min
[P_2] Set value of OUT2 *	100 L/min
[H_2] Hysteresis of OUT2 *	10 L/min

\*: Only available for models with switch outputs for both OUT1 and OUT2

\*: For hysteresis, please refer to [F 1] Setting of OUT1 (page 35), [F 2] Setting of OUT2 (page 40).

## Simple Setting Mode

<Operation>

[Simple setting mode (Hysteresis mode)]

In the Simple setting mode, the set value and hysteresis can be changed.

- (1) Press the SET button once in measurement mode.  
[P\_1] or [n\_1] and the [current set value] are displayed alternately.



- (2) Change the set value using the UP or DOWN button, and press the SET button to set the value. Then, the setting moves to hysteresis setting.  
(The snap shot function can be used. (Refer to page 64))

• Press the UP button continuously to keep increasing the set value.

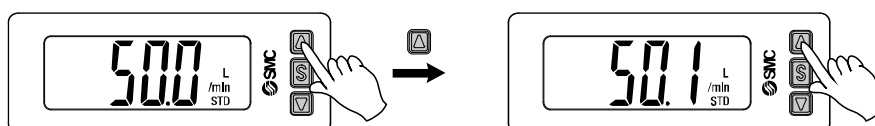

• Press the DOWN button continuously to keep decreasing the set value.

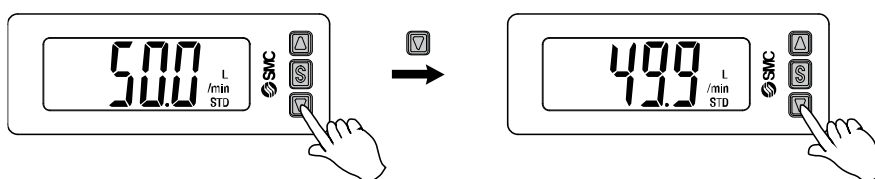

- (3) [H\_1] and the current set value are displayed in turn.

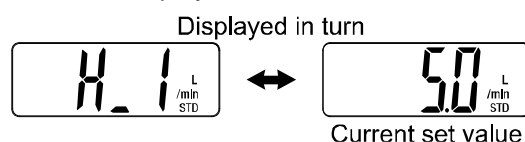

- (4) Change the hysteresis by pressing the UP or DOWN button and press the SET button. Setting is completed and the product returns to measurement mode.  
(The snap shot function can be used. (Refer to page 64))

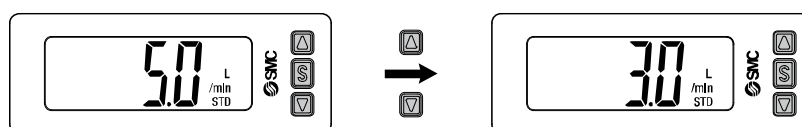

- \*: For models with switch outputs for both OUT1 and OUT2, [P\_2] or [n\_2] will be displayed. These are set simultaneously.
- \*: After enabling the setting by pressing the SET button, it is possible to return to measurement mode by pressing the SET button for 2 seconds or longer.
- \*: When hysteresis mode is not used, "Input set value" (page 53) is displayed.
- \*: The set value and hysteresis settings limit each other.
- \*: For more detailed setting, set each function in function selection mode (page 30).

# Function Setting

## Function selection mode

In measurement mode, press the SET button between 2 to 5 seconds, to display [F 0].

The [F□□] indicates the mode for changing each Function Setting.

Press the SET button for 2 seconds or longer in function selection mode to return to measurement mode.

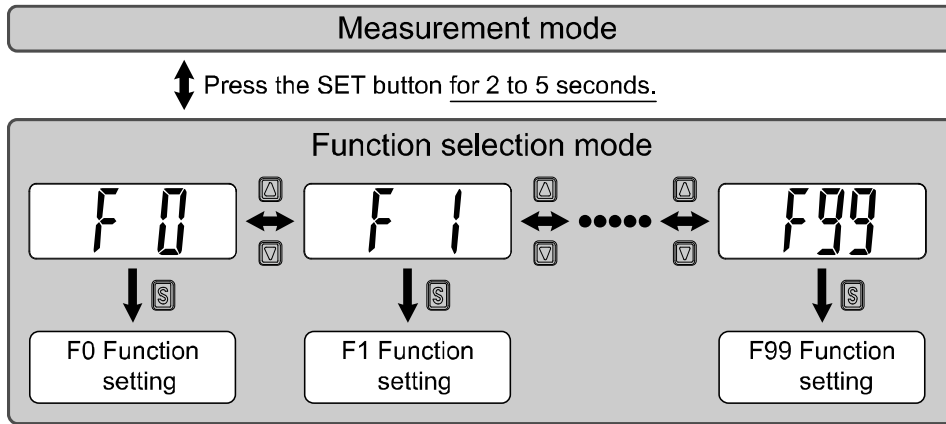

\*: Some products do not have all the functions. If no function is available or selected due to configuration of other functions, [- - -] is displayed.

## ■ Default setting

The default setting is as follows.

If no problem is caused by this setting, keep these settings.

To change a setting, enter function selection mode.

	Item	Default setting	Page
[F 0] ⇔ [FLU]	[FLU] Switch the flow rate	[Air] Dry air, N <sub>2</sub>	Page 33
	[rEF] Setting the units criteria	[Std] Standard condition	
	[Unit] Measurement unit switching *1	[ ] L/min (L)	
	[norP] SW output PNP/NPN setting *4	[PnP] PNP output	
	[i_o] SW/external input setting *4 *5	[oUt] SW output	
[F 1] ⇔ [oUt1]	[oUt1] Setting of OUT1	[HYS] Hysteresis mode	Page 35
	[1ot] OUT1 output configuration setting	[1_P] Normal output	
	[P_1] Set value	[ ] 50% of maximums rated flow PF2M701: 0.5 L/min, PF2M702: 1.0 L/min PF2M705: 2.5 L/min, PF2M710: 5 L/min PF2M725: 12.5 L/min, PF2M750: 25 L/min PF2M711: 50 L/min, PF2M721: 100 L/min	
	[H_1] Hysteresis	[ ] 5% of maximums rated flow PF2M701: 0.05 L/min, PF2M702: 0.1 L/min PF2M705: 0.25 L/min, PF2M710: 0.5 L/min PF2M725: 1.3 L/min, PF2M750: 2.5 L/min PF2M711: 5 L/min, PF2M721: 10 L/min	
	[dt1] Delay time setting	[0.00] 0.00 s	
	[CoL] Display colour setting	[1SoG] ON: Green OFF: Red	
[F 2] ⇔ [oUt2]	[oUt2] Setting of OUT2 *2	[HYS] Hysteresis mode	Page 40
	[2ot] OUT2 output configuration setting *2	[2_P] Normal output	
	[P_2] Set value *2	[ ] 50% of maximums rated flow PF2M701: 0.5 L/min, PF2M702: 1.0 L/min PF2M705: 2.5 L/min, PF2M710: 5 L/min PF2M725: 12.5 L/min, PF2M750: 25 L/min PF2M711: 50 L/min, PF2M721: 100 L/min	
	[H_2] Hysteresis *2	[ ] 5% of maximums rated flow PF2M701: 0.05 L/min, PF2M702: 0.1 L/min PF2M705: 0.25 L/min, PF2M710: 0.5 L/min PF2M725: 1.3 L/min, PF2M750: 2.5 L/min PF2M711: 5 L/min, PF2M721: 10 L/min	
	[dt2] Delay time setting *2	[0.00] 0.00 s	
	[CoL] Display colour setting *2	[1SoG] ON: Green OFF: Red	
[F 3] ⇔ [FiL]	[FiL] Digital filter setting	[1.0] 1.0 s	Page 44
[F 4] ⇔ [PrS]	[PrS] Auto-preset function setting	[oFF] Manual	Page 45



Item		Default setting	Page
[F10] ⇔ [FLo]	[FLo] Display mode	[inS] Instantaneous flow	Page 47
[F11] ⇔ [drE]	[drE] Display resolution setting	[1000] 1000-split	Page 48
[F13] ⇔ [rEv]	[rEv] Set Reverse display	[oFF] Not reverse	Page 49
[F14] ⇔ [CUt]	[CUt] Zero cut-off setting	[1.0] 1% of maximums rated flow PF2M701: 0.01 L/min, PF2M702: 0.02 L/min PF2M705: 0.05 L/min, PF2M710: 0.1 L/min PF2M725: 0.3 L/min, PF2M750: 0.5 L/min PF2M711: 1 L/min, PF2M721: 2 L/min	Page 50
[F20] ⇔ [inP]	[inP] External input setting *5	[rAC] Accumulated value reset	Page 51
[F22] ⇔ [AoUt]	[AoUt] Analogue output setting *3	[1-5] 1 to 5 V Voltage output (when voltage is output) [---] Analogue output is not selectable (for current type output)	Page 52
[F30] ⇔ [SAvE]	[SAvE] Accumulated flow value hold setting	[oFF] Not held	Page 54
[F80] ⇔ [diSP]	[diSP] Display OFF mode setting	[ on] Normal display	Page 55
[F81] ⇔ [Pin]	[Pin] Security code	[oFF] Unused	Page 56
[F90] ⇔ [ALL]	[ALL] Setting of all functions	[oFF] Unused	Page 57
[F96] ⇔ [S_in]	[S_in] External input signal check *5	No setting due to input signal setting	Page 59
[F98] ⇔ [tESt]	[tESt] Output checking	[ n] Normal output	Page 60
[F99] ⇔ [ini]	[ini] Reset to the default settings	[oFF] Not recover	Page 63

\*1: Setting is only possible for models with the units selection function.

\*2: Only available for models with switch outputs for both OUT1 and OUT2.

\*3: This function is available for models with analogue output.

Analogue free span function can be selected.

\*4: This function is available in IO-Link compatible products.

\*5: This function is available for models with external input.

■ [F 0] Fluid/Units criteria/Measurement unit setting

Set the type of operating fluid, display units criteria and measurement unit switching.

<Operation>

Press the UP or DOWN button in function selection mode to display [F 0].

Press the SET button. ↓ Move on to the setting of fluid.

**Fluid setting**  
Press the UP or DOWN button to select the operating fluid.

Displayed in turn

Press the SET button to set. ↓ Move on to the setting of units criteria.

**Units criteria setting**  
Press the UP or DOWN button to select the reference condition.

Displayed in turn

Standard condition      Normal condition

\*: Standard condition: Displayed flow rate which is converted to volume at 20 [°C], 101.3 [kPa] (Absolute pressure), 65 [%R.H.].

\*: Normal condition: Displayed flow rate which is converted to volume at 0 [°C], 101.3 [kPa] (Absolute pressure), 0 [%R.H.].

Press the SET button to set. ↓ Move on to the setting of measurement unit.



### Measurement unit setting

Press the UP or DOWN button to select the measurement unit.

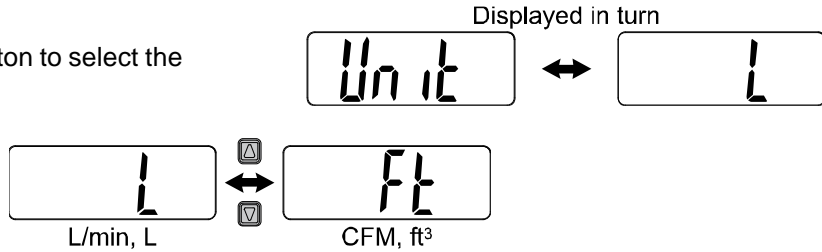

\*: This setting is not available for models which are fixed to SI units.

↓ For IO-Link compatible product

### SW output PNP/NPN setting

Press the UP or DOWN button to select SW output.

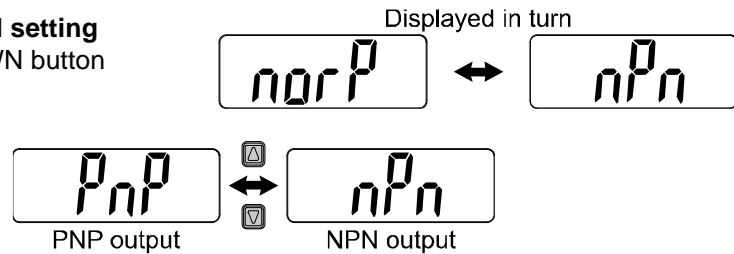

↓ For the model with external input function

### SW output/external input setting

Press the UP or DOWN button to set OUT2.

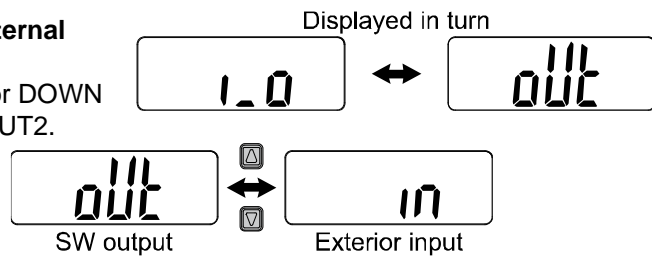

Press the SET button to set. ↓ Return to function selection mode.

[F 0] Fluid/Units criteria/Measurement unit setting is completed

### ● Available display unit and minimum set value

Display mode	Unit	PF2M701	PF2M702	PF2M705	PF2M710	PF2M725	PF2M750	PF2M711	PF2M721
Instantaneous	L/min	0.001	0.01	0.01	0.01	0.1	0.1	0.1	1
	cfm	0.1	0.1	0.001	0.001	0.001	0.01	0.01	0.01
Accumulated	L	0.01	0.01	0.1	0.1	1	1	1	1
	ft <sup>3</sup>	0.001	0.001	0.001	0.01	0.01	0.01	0.1	0.1

\*: The display unit of PF2M701 and PF2M702 is cfm×10<sup>-3</sup>.

■[F 1] Setting of OUT1  
Set output method of OUT1.

<Operation>

Press the UP or DOWN button in function selection mode to display [F 1].

Press the SET button. ↓ Move on to output mode setting.

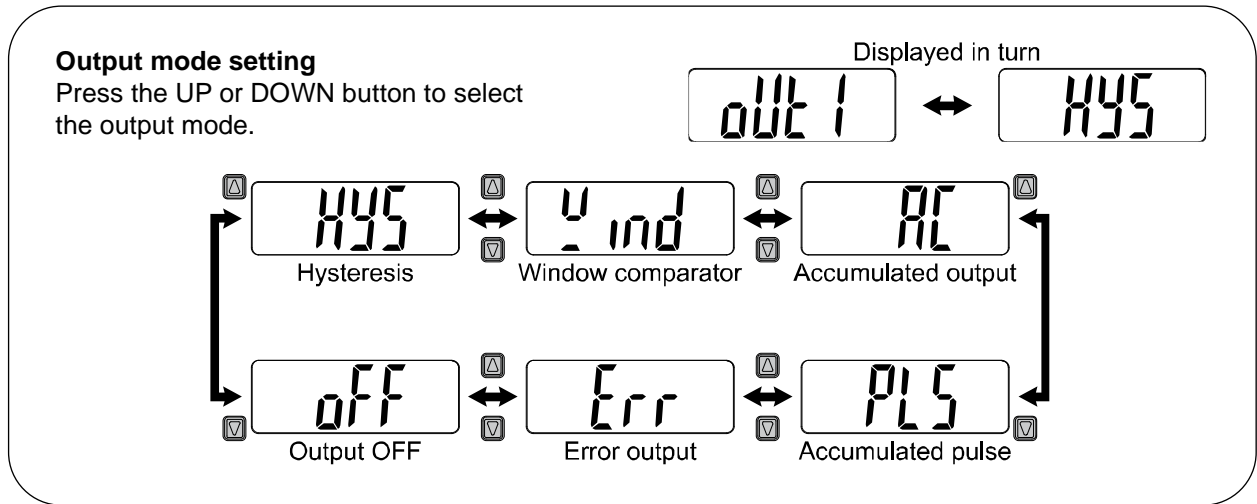

Press the SET button to set. ↓ Move on to the output type setting.

[OFF] is selected  
Press the SET button to move on to display colour setting.

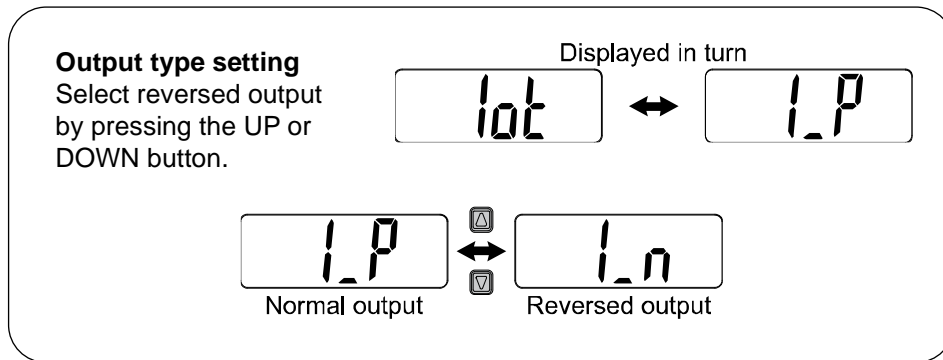

Press the SET button to move on to flow setting.

[AC] is selected  
Press the SET button to select the display for count-up (addition) and count-down (decrement).

[PLS], [Err] are selected  
Press the SET button to move on to display colour setting.

**Select the display for count-up (addition) and countdown (decrement)**

[AC] and the current set value are displayed in turn.

Displayed in turn



Press the UP or DOWN button to select the counting style.

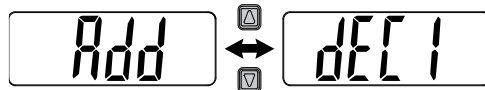

Count-up  
(Addition)

Count-down  
(Decrement)

Press the SET button to move on to flow setting.

**Flow setting**

Set the pressure based on the setting method on page 28.

Displayed in turn



Hysteresis mode: [P\_1]

Window comparator mode: [P1L] [P1H]

Accumulated output: [ P1]

"P" is changed to "n" as [P\_1] → [n\_1] when reversed output is selected.

The snap shot function can be used.

(Refer to page 64)

\*: Note that the set value will apply a limit to the value entered for hysteresis, and vice versa.

When the input of the set value is restricted, the restriction is removed by setting the hysteresis to 0.

Press the SET button to move on to hysteresis setting.

[AC] is selected  
Press the SET button to move on to display colour setting.



### Hysteresis setting

Set the pressure referring to the setting method on page 29.

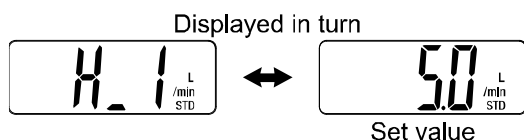

Hysteresis mode: [H\_1]  
Window comparator mode: [H1]  
The snap shot function can be used.  
(Refer to page 64)

Press the SET button to set.



Move on to delay time setting.

### Delay time setting

Press the UP or DOWN button to select the delay time.

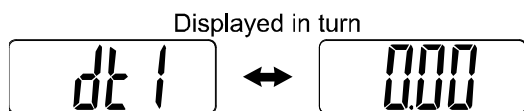

Press the SET button to set.



Move on to display colour setting.



**Display colour setting**

Press the UP or DOWN button to select the display colour.

Displayed in turn

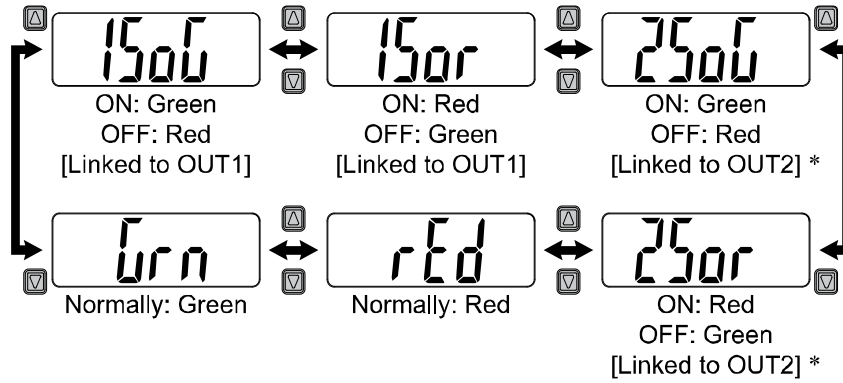
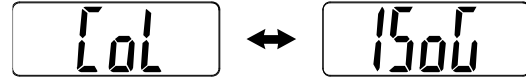

\*: Output specification: C, D, E and F are not displayed.

Press the SET button to set. ↓ Return to function selection mode.

[F 1] Setting of OUT1 completed

•List of output modes

	Normal output	Reversed output
Hysteresis mode		
Window comparator mode		
Accumulated output mode (Addition)	<ul style="list-style-type: none"> <li>• Count up from "0".</li> <li>• Turn ON when the set value is reached.</li> <li>• Return to "0" by reset.</li> </ul>	<ul style="list-style-type: none"> <li>• Count up from "0".</li> <li>• Turn OFF when the set value is reached.</li> <li>• Return to "0" by reset.</li> </ul>
Accumulated output mode (Decrement)	<ul style="list-style-type: none"> <li>• Count down from set value.</li> <li>• Turn ON when the "0" is reached.</li> <li>• Return to set value by reset.</li> </ul>	<ul style="list-style-type: none"> <li>• Count down from set value.</li> <li>• Turn OFF when the "0" is reached.</li> <li>• Return to set value by reset.</li> </ul>
Accumulated pulse output mode		
Error output mode		
OFF mode		

\*1: The applicable errors are Er1, 2, 6, 8 and 40,

\*: The chart above shows the OUT1 operation. For OUT2, all "1" in the chart will be changed to "2". (example P\_1→P\_2)

If the point at which the switch output changes is outside of the set pressure range due to the selection of normal or reversed output, the hysteresis value is automatically adjusted.



## ■[F 2] Setting of OUT2

Set output method of OUT2.

\*: When the product without OUT2 (switch output) is used, [--] will be displayed and this function cannot be set.

<Operation>

Press the UP or DOWN button in function selection mode to display [F 2].

Press the SET button. ↓ Move on to output mode setting.

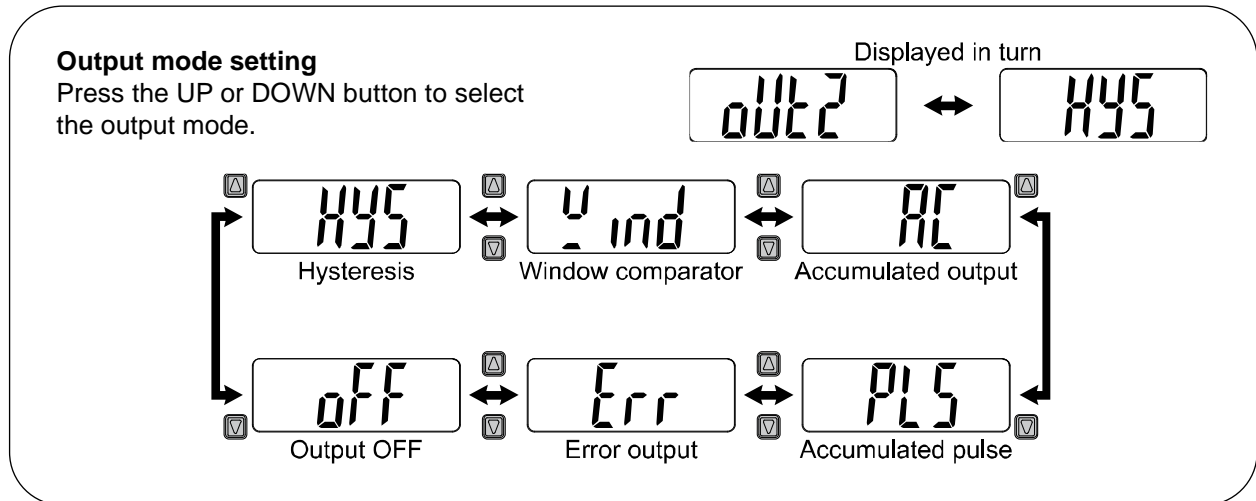

Press the SET button to set. ↓ Move on to the output type setting.

[off] is selected  
Press the SET button to move on to display colour setting.

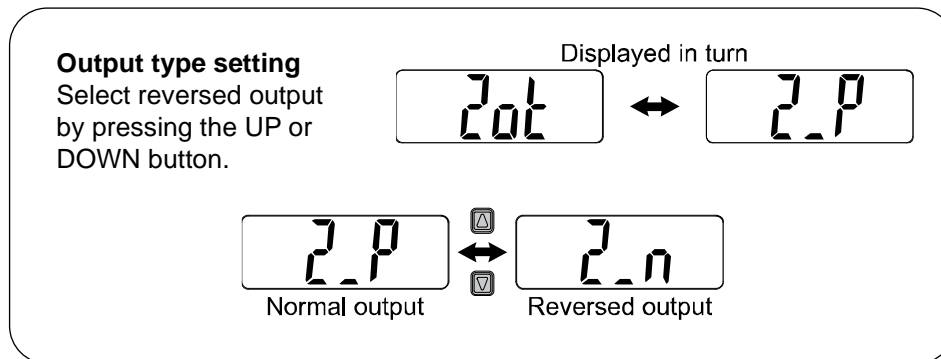

Press the SET button to move on to flow setting.

[AC] is selected  
Press the SET button to select the display for count-up (addition) and count-down (decrement).

[PLS], [Err] are selected  
Press the SET button to move on to display colour setting.

**Select the display for count-up (addition) and countdown (decrement)**

[AC] and the current set value are displayed in turn.

Displayed in turn



Press the UP or DOWN button to select the counting style.

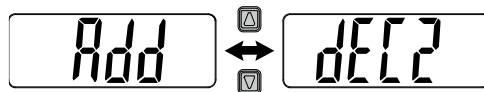

Count-up  
(Addition)

Count-down  
(Decrement)

Press the **SET** button to move on to flow setting.

**Flow setting**

Set the pressure based on the setting method on page 28.

Displayed in turn

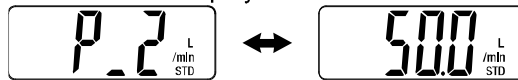

Hysteresis mode: [P\_2]

Window comparator mode: [P2L] [P2H]

Accumulated output: [ P2]

"P" is changed to "n" as [P\_2] → [n\_2] when reversed output is selected.

The snap shot function can be used.

(Refer to page 64)

\*: Note that the set value will apply a limit to the value entered for hysteresis, and vice versa.

When the input of the set value is restricted, the restriction is removed by setting the hysteresis to 0.

Press the **SET** button to move on to hysteresis setting.

[AC] is selected  
Press the **SET** button to move on to display colour setting.



### Hysteresis setting

Set the pressure referring to the setting method on page 29.

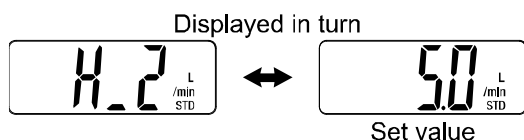

Hysteresis mode: [H\_2]  
Window comparator mode: [H2]  
The snap shot function can be used.  
(Refer to page 64)

Press the SET button to set.



Move on to delay time setting.

### Delay time setting

Press the UP or DOWN button to select the delay time.

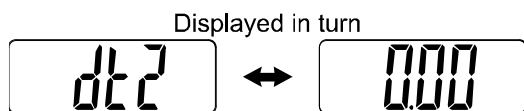

Press the SET button to set.



Move on to display colour setting.





### Display colour setting

Press the UP or DOWN button to select the display colour.

Displayed in turn

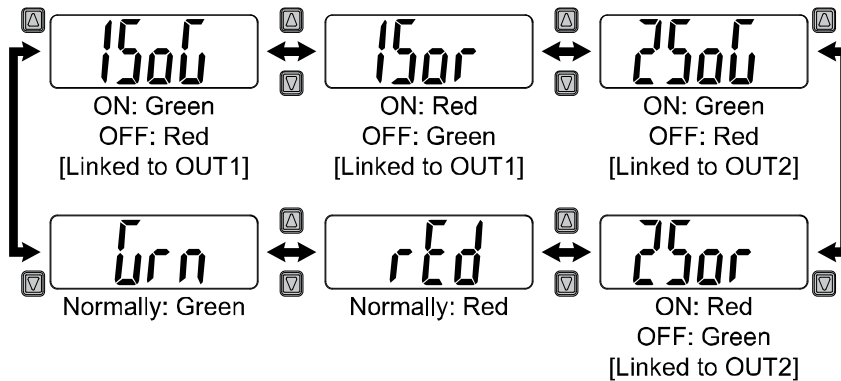
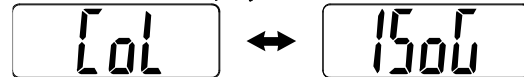

Press the SET button to set. ↓ Return to function selection mode.

[F 2] Setting of OUT2 completed

### ■ [F 3] Digital filter setting

The digital filter can be selected to filter the flow measurement.

Output chattering or flicker in the measurement mode display can be reduced by setting the digital filter.

<Operation>

Press the UP or DOWN button in function selection mode to display [F 3].

Press the SET button. ↓ Move on to digital filter setting.

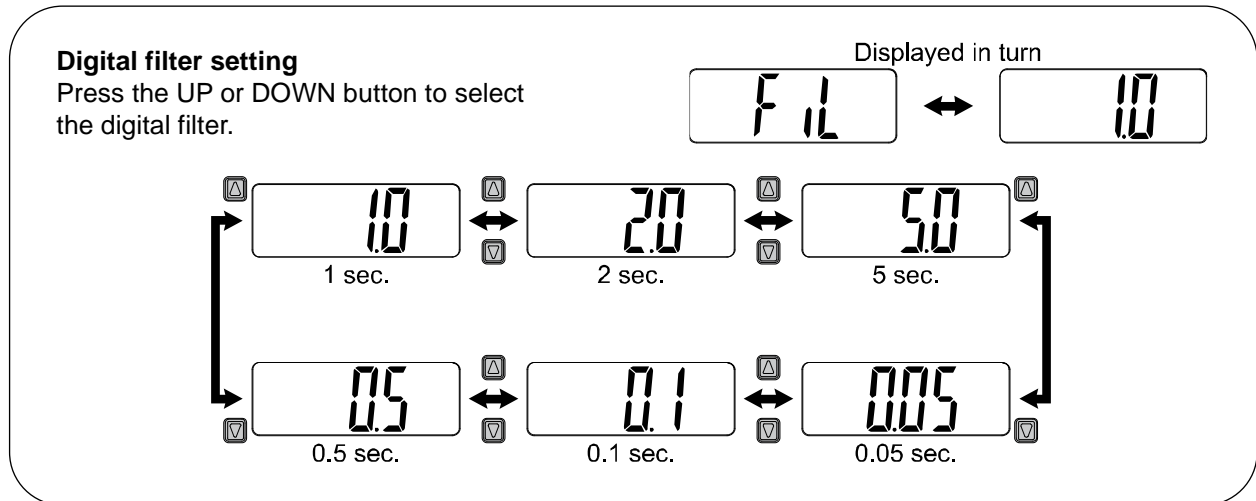

Press the SET button to set. ↓ Return to function selection mode.

[F 3] Digital filter setting completed

#### ■ [F 4] Auto-preset function setting

This function will automatically calculate and set the optimum pressure based on the actual operating condition, when hysteresis mode has been selected.

<Operation>

Press the UP or DOWN button in function selection mode to display [F 4].

Press the SET button. ↓ Move on to Auto-preset function setting.

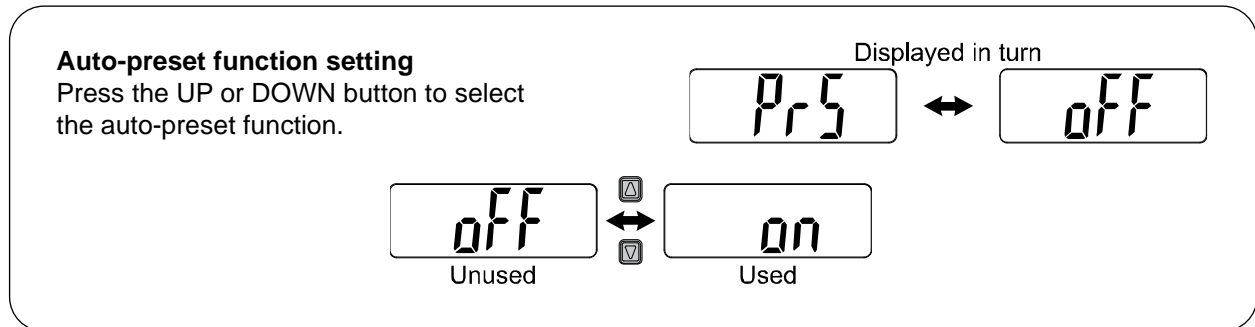

Press the SET button to set. ↓ Return to function selection mode.

[F 4] Auto-preset function setting completed

●Auto-preset

When auto-preset is selected in function selection mode, the set value can be calculated and memorized from the measured flow. Repeating the suction and release of the workpiece to be set for several times will automatically optimize the set value.

(1) Selection of auto-preset OUT1 mode

Press the SET button in measurement mode to display [AP1].  
 (If setting of OUT1 is not necessary, select [AP1], and then press the UP and DOWN buttons simultaneously for 1 second or longer.  
 The display will move to [AP2]).



Auto-preset is ready

(2) Preparation of equipment for OUT1

Prepare the equipment for which the flow of OUT1 is to be set.

(3) Setting of auto-preset for OUT1

Press the SET button to flash [AP1].  
 Measurement starts. Operate the device to change the flow.  
 (If the UP and DOWN buttons are pressed simultaneously for 1 second or longer while "AP1" is displayed, measurement will be stopped and [AP2] will return.)



Auto-preset measurement start

(4) Selection of auto-preset OUT2 mode

Press the SET button to set [P\_1], [H\_1] ([n\_1], [H\_1] in reverse output mode) to display [AP2].  
 (If the setting of OUT1 is not necessary, press the UP and DOWN buttons simultaneously for 1 second or longer after [AP1] display. The display will move to measurement mode).

(5) Preparation of equipment for OUT2

Prepare equipment for which the flow of OUT2 is to be set, and set the value of OUT2 as in OUT1.  
 [AP2 RUN] will be flashed and measurement will start.  
 (If the UP and DOWN buttons are pressed simultaneously for 1 second or longer while "AP1" is displayed, measurement will be stopped and measurement mode will return.)

(6) Complete setup

Press the SET button to set the set value of [P\_2] and [H\_2] and complete the auto-preset mode. Then, measurement mode returns.  
 ([n\_2], [H\_2] in reverse output mode.)

The settings and hysteresis in auto-preset will be as follows.

Output type	Setting items	Calculation formula	A: Maximum measured auto-preset value
			B: Minimum measured auto-preset value
Normal	Set value	Calculated value = $A - \frac{A-B}{4}$	
Reverse		Calculated value = $B + \frac{A-B}{4}$	
Normal Reverse	Hysteresis	Calculated value = $\frac{A-B}{2}$	

If setting is not necessary press the UP and DOWN buttons simultaneously for 1 second or longer.

## ■[F10] Display mode setting

Select instantaneous flow or accumulated flow to be displayed.

<Operation>

Press the UP or DOWN button in function selection mode to display [F 4].

Press the SET button. ↓ Move on to display mode setting.

**Display mode setting**  
Press the UP or DOWN button to select the display mode setting.

Displayed in turn

FlO

↔

InS

InS

Instantaneous flow

↔

AC

Accumulated flow

↔

IOl

IO-Link mode display\*

\*: This function is available in IO-Link compatible products.

Press the SET button to set. ↓ Return to function selection mode.

[F10] Display mode setting completed

- The accumulation flow count will start when power is supplied.  
Accumulated flow can be displayed within the range below.

Unit	PF2M701	PF2M702	PF2M705	PF2M710
L	9999999.99	9999999.99	99999999.9	99999999.9
ft <sup>3</sup>	999999.999	999999.999	999999.999	999999.999

Unit	PF2M725	PF2M750	PF2M711	PF2M721
L	999999999	999999999	999999999	999999999
ft <sup>3</sup>	9999999.99	9999999.99	99999999.9	99999999.9

- Accumulated flow is displayed to the Power (x103, x106) and the first 4 digits are constantly displayed.

Accumulated flow value Unit: L	Display (Power value is displayed.)		3 types of display		
	Display screen	Units indication	Upper	Middle	Lower
0.0	0.0	LED is off	0	0	0.0
1234.0	1.234	×10 <sup>3</sup>	0	12	34.0
7654321.0	7.654	×10 <sup>6</sup>	76	543	21.0
99999999.9 or more	99.9 (flashing)	×10 <sup>6</sup>	999 (flashing)	999 (flashing)	999 (flashing)

- The accumulated value can be reset as follows.
  - Reset by pressing the SET button. (Refer to page 65)
  - Turn the power on.  
(When using the accumulated value hold is used (page 54), reset cannot be performed even if the power is applied again.)



## ■[F11] Display resolution setting

This function is only available for the 1, 10 and 100 L/min types.

The minimum setting unit can be changed by selecting the display resolution.

<Operation>

Press the UP or DOWN button in function selection mode to display [F11].

Press the SET button. ↓ Move on to display resolution setting.

**Display resolution setting**  
Press the UP or DOWN button to select the display resolution.



1000-split







100-split



drE





1000

Displayed in turn

Press the SET button to set. ↓ Return to function selection mode.

[F11] Display resolution setting completed

## ■[F13] Setting for reverse display mode

The display orientation can be changed for ease of operation.

It is used to correct the display when it is upside down due to installation of the product.

<Operation>

Press the UP or DOWN button in function selection mode to display [F13].

Press the SET button. ↓ Move on to the setting for reverse display mode.

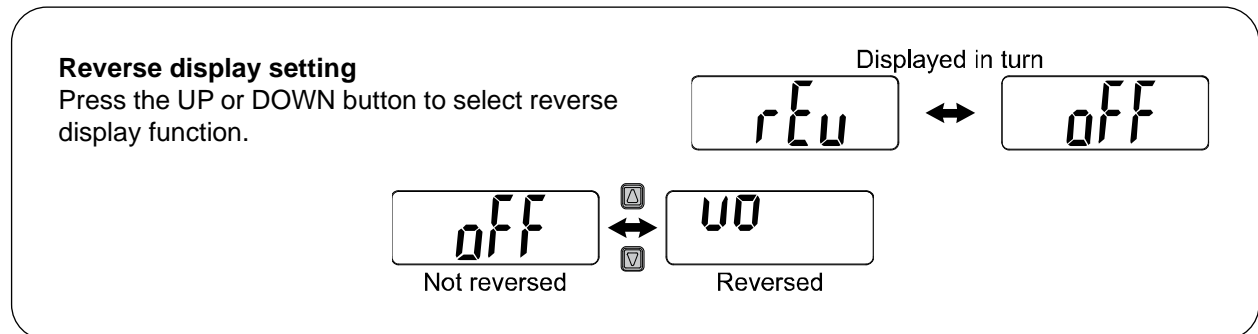

Press the SET button to set. ↓ Return to function selection mode.

[F13] Setting for reverse display mode completed

## ■[F14] Zero cut-off setting

This function forces a zero display when the flow is within the 0 to 10% area of the flow range.

### <Operation>

Press the UP or DOWN button in function selection mode to display [F14].

Press the SET button. ↓ Move on to the setting of the zero cut-off function.

**Setting of zero cut-off function**  
Press the UP or DOWN button to select the zero cut-off function.

Displayed in turn

Zero cut-off range increase

Zero cut-off range decrease

Press the SET button to set. ↓ Move on to checking the zero cut-off set value.

**Check the zero cut-off set value**  
The set zero cut-off range is displayed in percent (%).

Displayed in turn

Zero cut-off value (percent)

Zero cut-off value (percent)

\*: For models with IO-Link output

During the checking of the Zero cut-off set value  
Press the UP and DOWN button simultaneously for 1 second or longer for resetting the set value (to the default value).

Press the SET button to set. ↓ Return to function selection mode.

[F14] Zero cut-off setting completed

## ■ [F20] Setting of external input

This function is available when the model includes the external input function.

The accumulated value, peak value and bottom value can be reset remotely.

\*: When using a model without external input function, this setting is not available and [---] will be displayed.

● **Accumulated flow external reset:** A function to reset the accumulated flow value when an external input signal is applied.

When "Count up display", the accumulated flow value will reset to zero, and then increase from zero. When "Count down display", the accumulated flow value will reset to a set value, and then decrease from the set value.

\*: Each time the accumulated flow external reset is activated and when the accumulated flow value is stored, a memory device (EEPROM) is accessed. The memory device has a limit of 1 million cycles. When using the product, it should be considered that the total number of external input resets and accumulated values stored must not exceed 1 million.

● **Peak/Bottom external reset:** A function to clear the peak value or bottom value when an external input signal is applied.

● **OFF:** The external input function will not operate.

<Operation>

Press the UP or DOWN button in function selection mode to display [F20].

Press the SET button. ↓

[F20] and [inP] are displayed in turn.

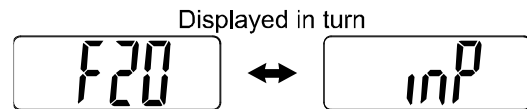

Press the SET button to set. ↓ Move on to setting of external input.

### Setting of external input

[inP] and [the current set value] are displayed in turn.  
Press the UP or DOWN button to select.

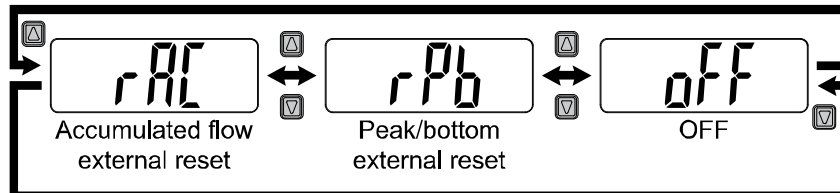
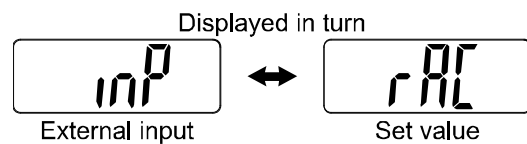

Press the SET button to set. ↓ Return to function selection mode.

[F20] Setting of external input completed

**Input signal:** The external input line must be connected to GND for a minimum of 30 msec.

- When the input signal is ON, the screen will display [ooo] for 1 second.
- After turning OFF the input signal, flow accumulation resumes (displays peak value and bottom value) within 30 msec.
- To input successive signals, the [ooo] display must clear before the next signal is input.

## ■ [F22] Analogue output and analogue free span function setting

This function is available when the model includes the analogue output.  
Change the analogue output set value and analogue free span.

<Operation>

Press the UP or DOWN button in function selection mode to display [F22].

Press the SET button. ↓ Move on to the setting of analogue output.

**Setting of analogue output (only voltage output)**  
Press the UP or DOWN button to select 1 to 5 V output or 0 to 10 V output.

Displayed in turn

▲  
Aout ↔ 1-5  
▼

▲  
1-5 ↔ 0-10  
▼

1 to 5V output      0 to 10 V output

\*: Only 4 to -20 mA is available for current output. The display will be [--] and not settable.  
\*: When current output is used with IO-Link compatible products, only 4 to 20 mA is available

Press the SET button to set. ↓ Move on to the setting of analogue free span.

**Setting of analogue free span**  
Press the UP or DOWN button to select analogue free span function.

Displayed in turn

▲  
Free ↔ off  
▼

▲  
off ↔ on  
▼

Analogue free span OFF      Analogue free span ON

[off] is selected

Press the SET button to set.

[on] is selected

Press the SET button to set.

### Input of set value

Press the UP or DOWN button to set the flow value that will be output, 5 V (10 V) or 20 mA.

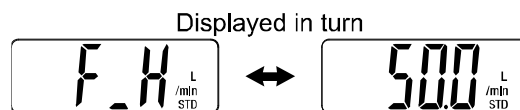

The entered flow value can be in the range: 10% of the max. rated flow, to the upper display limit.

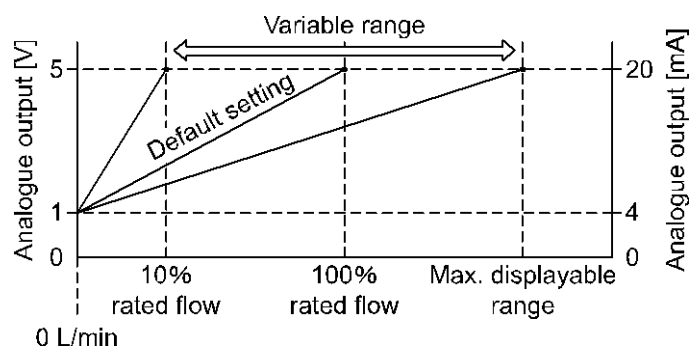

Press the SET button to set. ↓ Return to function selection mode.

[F22] Analogue output analogue free span setting function setting completed

## ■ [F30] Accumulated flow value hold setting

The accumulated flow value can be held for 2 or 5 minutes.

### <Operation>

Press the UP or DOWN button in function selection mode to display [F30].

Press the SET button. ↓ Move to the accumulated flow value hold setting.

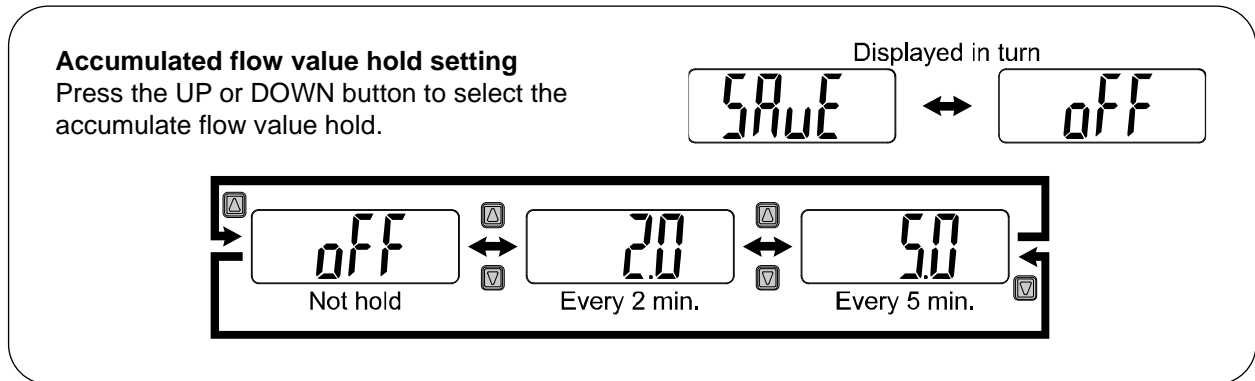

Press the SET button to set. ↓ Return to function selection mode.

[F30] Setting of accumulated flow value hold completed

\*: When using the Accumulated flow hold function, calculate the product life according to the operating conditions, and use the product within its life. The limit of the number times the memory can be written to is 3.7 million times. If the product is operated 24 hours per day, the life will be as follows.

- Data stored every 5 minutes: 5 minutes x 3.7 million cycles = 18.5 million minutes = 35 years
- Data stored every 2 minutes: 2 minutes x 3.7 million cycles = 7.4 million minutes = 14 years

\*: The value is stored in memory every 2 or 5 minutes. If the power supply is turned off, the accumulated flow since the last time it was stored will be lost.

\*: When the power supply is turned on again, the accumulated flow count will start from the last value recorded at B.

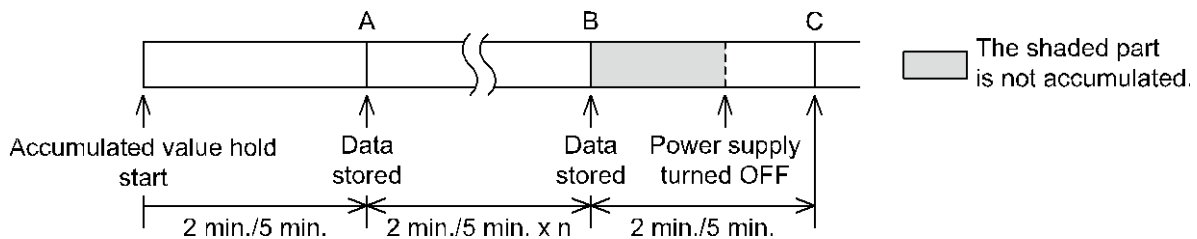

## ■[F80] Display OFF mode setting

Display OFF mode can be selected.

This function will turn the display OFF if no buttons are pressed for 30 seconds.

<Operation>

Press the UP or DOWN button in function selection mode to display [F80].

Press the SET button. ↓ Move on to the setting of display OFF mode.

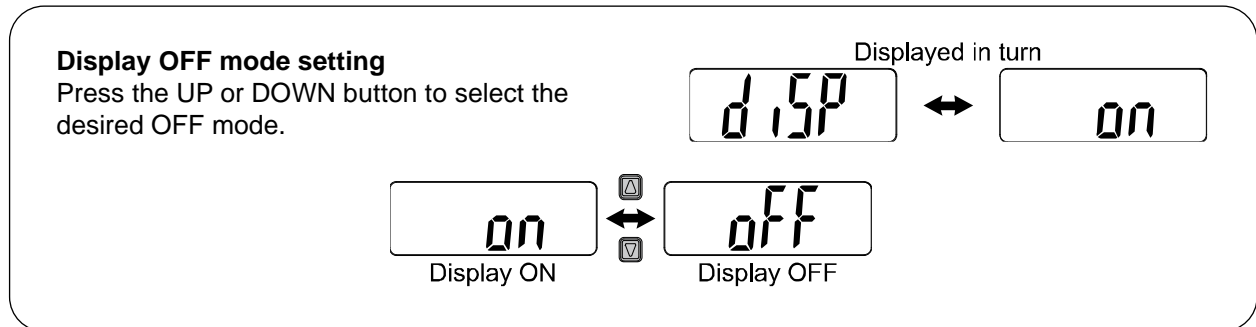

Press the SET button to set. ↓ Return to function selection mode.

[F80] Setting of display OFF mode completed

\*: In display OFF mode, the under bar of sub display flashes.

\*: When any button is activated, the display will turn on. If no button operation is performed within 30 seconds, the display will turn off again.

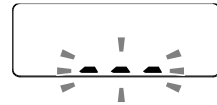



## ■ [F81] Security code

The security code can be turned on or off and the security code can be changed when unlocked.

<Operation>

Press the UP or DOWN button in function selection mode to display [F81].

Press the SET button. ↓ Move on to security code.

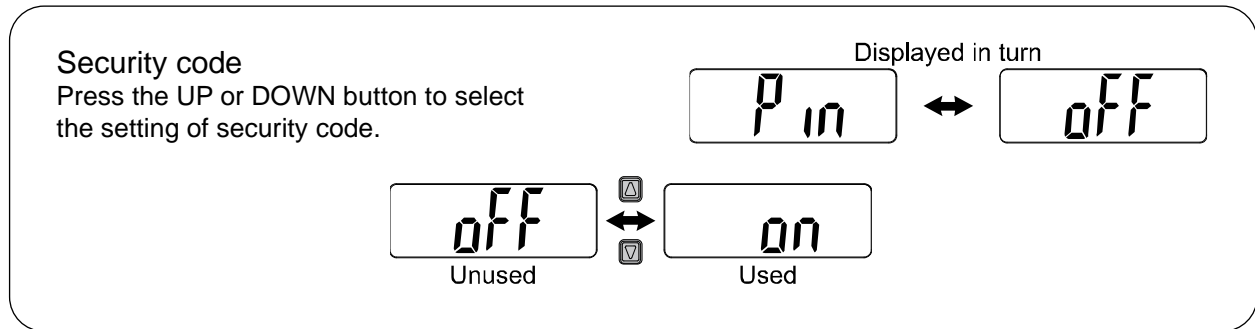

■  
[oFF] is selected  
Press the SET button to return to function selection mode.

[on] is selected  
Press the SET button to set. ↓ Move on to check of the setting of security code.

### Check of the setting of security code

Press the UP or DOWN button to set security code.  
(The default setting is [000].)

For instructions on how to enter the security code, refer to "How to input and change the security code" on page 69.

After entry, the changed security code will flash by pressing the SET button for 1 second.  
(At this point, the changing of the security code is not completed)

Press the UP or DOWN button to return to setting step.

If the security code entered is incorrect, [FAL] will be displayed, and the security code must be entered again.

If the wrong security code is entered 3 times, [LoC] is displayed.



Press the SET button to set. ↓ Return to function selection mode.

[F81] Security code completed

## ■[F90] Setting of all functions

Each time the S button is pressed, the function steps in the order shown in the following table.

<Operation>

Press the UP or DOWN button in function selection mode to display [F90].

Press the SET button. ↓ Move on to setting of all function.

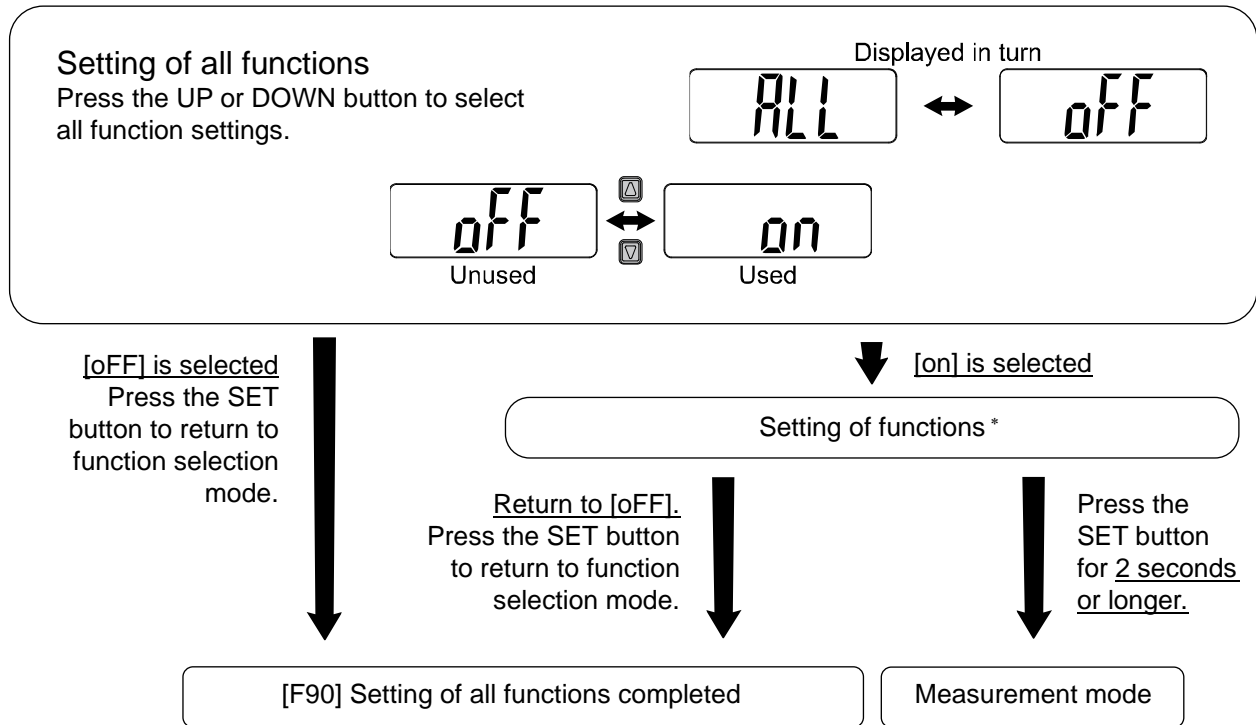

\*: Setting of functions

Every time the SET button is pressed, the next function is displayed in order (refer to the following table). Set by using the UP or DOWN buttons.

Refer to each paragraph for the setting details.

●Order of Function Setting

Order	Function
1	Fluid/Units criteria/measurement unit setting
2	Setting of OUT1
3	Setting of OUT2
4	Digital filter setting
5	Auto-preset function setting
6	Display mode
7	Display resolution setting
8	Reverse display setting
9	Setting of zero cut-off function
10	Analogue output and free span function
11	Accumulated flow value hold setting
12	Set display OFF mode
13	Security code

\*: Measurement mode can return from any setting item by pressing the SET button for 2 seconds or longer.

\*: Function set before returning to the measurement mode is maintained.

## ■[F96] Check of external input signal

This function is selectable when the model includes the external input function.  
The existence of an external input signal can be checked.

<Operation>

Press the UP or DOWN button in function selection mode to display [F96].

Press the SET button. ↓ Move to the external input signal check window.

**Check of external input signal**

Displayed in turn

S_in	↔	off
When external input signal is ON		on
When external input signal is OFF		off
Terminal input is not available or input function is not available		---

Press the SET button to set. ↓ Return to function selection mode.

[F96] Check of external input signal is completed

## ■ [F98] Setting of output check

The switch output and analogue output can be checked.  
The output can be turned ON/OFF manually.

<Operation>

Press the UP or DOWN button in function selection mode to display [F98].

Press the SET button. ↓ Move on to the setting of output check.

**Setting of output check**  
Press the UP or DOWN button to select output check.

Displayed in turn

Normal output  
(Output not checked)

Fixed output  
(Output is checked)

■  
[n] (Normal output) is selected

Press the SET button to return to function selection mode.



[F] (Fixed output) is selected  
Press the SET button to set.

↓ Move on to output check of OUT1.

**Check of OUT1 output**  
Press the UP or DOWN button to select the OUT1 output check.

Displayed in turn

Output OFF

Output ON

Press the SET button to set. ↓ Move on the OUT2 output check.

**Check of OUT2**

Press the UP or DOWN button to select the OUT2 output check.

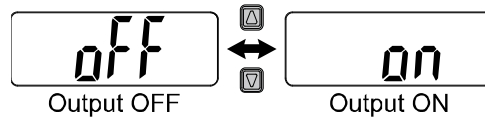
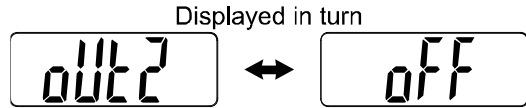

**•Analogue output**

Press the UP or DOWN button to select the analogue output check.

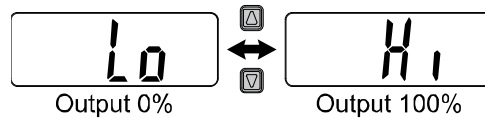
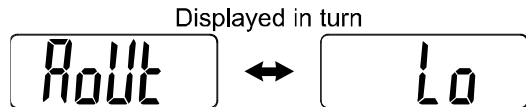

**•For IO-Link compatible product**

Press the UP or DOWN button to select the analogue output check.

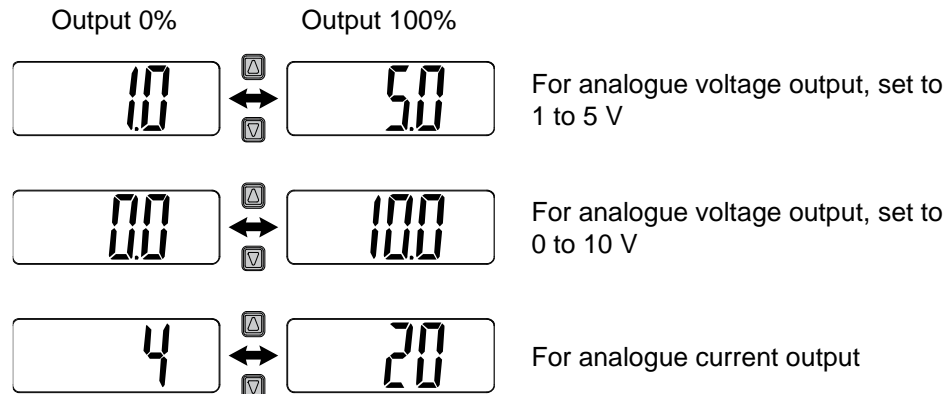
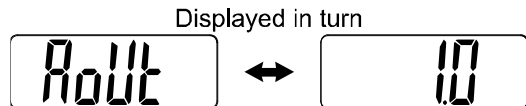

↓ For IO-Link compatible product with SDCI mode



**Diagnostic bit output check**  
Press the UP or DOWN button to select the diagnostic bit output check.

Displayed in turn

d1.1 ↔ off

off ↔ on

Output OFF      Output ON

Press the SET button to set. ↓ Move to error bit output check.

**Error bit output check**  
Press the UP or DOWN button to select the error bit output check.

Displayed in turn

d1.E ↔ off

off ↔ on

Output OFF      Output ON

Press the SET button to set. ↓ Move to process data output check.

**Process data output check**  
Press the UP or DOWN button to select the process data output check.

Displayed in turn

Pd.1 ↔ 0

0 ↔ 4000

PD value upper limit      PD value lower limit

Press the SET button for 2 seconds or longer. ↓ Return to function selection mode.

[F98] Output check completed

\*: Measurement mode can return from any setting item by pressing the SET button for 2 seconds or longer.

## ■ [F99] Reset to default settings

If the product settings are uncertain, the default values can be restored.

<Operation>

Press the UP or DOWN button in function selection mode to display [F99].

Press the SET button. ↓ Move on to reset to default settings.

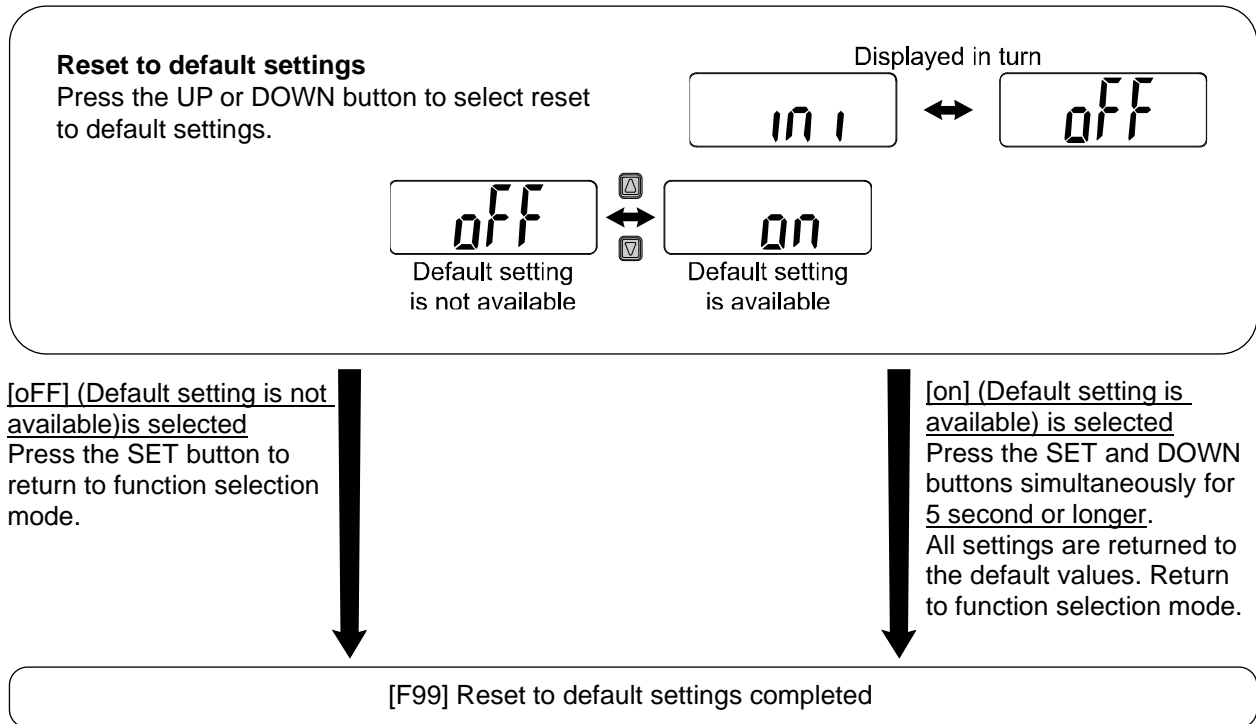



## Other Settings

- Snap shot function

The current flow value can be stored to the switch output ON/OFF set point.

When the threshold values have been selected from the table below during the setting of [F 1] OUT1 and [F 2] OUT2, in Simple setting mode or function selection mode, [---] is displayed when the UP and DOWN button are pressed simultaneously for 1 second or longer and the value according to the current flow rate is displayed automatically.

Output mode	Configurable items	Display	Snap shot function
Hysteresis mode	OUT1, OUT2 set value	P_1 (n_1), P_2 (n_2)	○
	Hysteresis	H_1, H_2	○
Window comparator mode	OUT1, OUT2 set value	P1L (n1L), P1H (n1H) P2L (n2L), P2H (n2H)	○
	Hysteresis	H1, H2	×

- OUT1 set value and OUT2 set value

The value is set to the same value as the flow value (current flow value).

(There is a range which cannot be set to the current flow depending on the hysteresis. In that case, the value is set to the closest value.)

- Hysteresis

The hysteresis is calculated from the equation below and set.

Normal output: (OUT1 (2) set value) - (current flow value)

Reverse output: (current flow value) - (OUT1 (2) set value)

If the calculation result becomes 0 or less, [Err] is displayed on the display and the set value is not changed.

Afterwards, it is possible to adjust the value by pressing the UP or DOWN button.

- Peak/bottom value indication

The maximum (minimum) flow when the power is supplied is detected and updated.

In peak/bottom indication mode, the current flow is displayed.

Current peak (bottom) value will be displayed by pressing the UP or DOWN button for 1 second or longer during measurement mode.

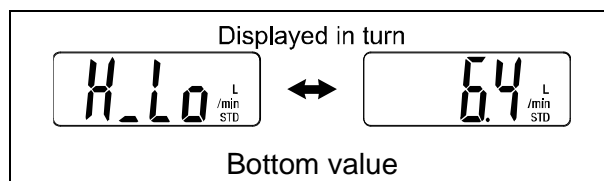
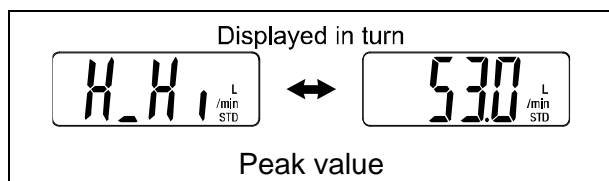

Peak/ Bottom value is cleared if the power supply is disconnected.  
Current peak (bottom) value will be cleared by pressing the UP and DOWN simultaneously button for 1 second or longer while peak/bottom value is displayed.



- Reset

Accumulated flow rate can be reset by pressing the SET and DOWN button simultaneously for 1 second or longer during accumulated flow.



Reset of the accumulated flow value

- Zero-clear function

The measured flow rate can be cleared to zero by pressing the UP and DOWN button simultaneously for 1 second or longer during instantaneous flow.

Zero-clear operation time will change according to the digital filter set value. The value can be adjusted within the range  $\pm 5\%$  F.S. from the default condition.



Zero-clear display

●Key-lock function

The key-lock function is used to prevent errors occurring due to unintentional changes of the set values. [LoC] is displayed on screen by pressing the SET button during key lock setting mode. Then, the current set value and hysteresis of OUT1 (OUT2) will be displayed in turn.

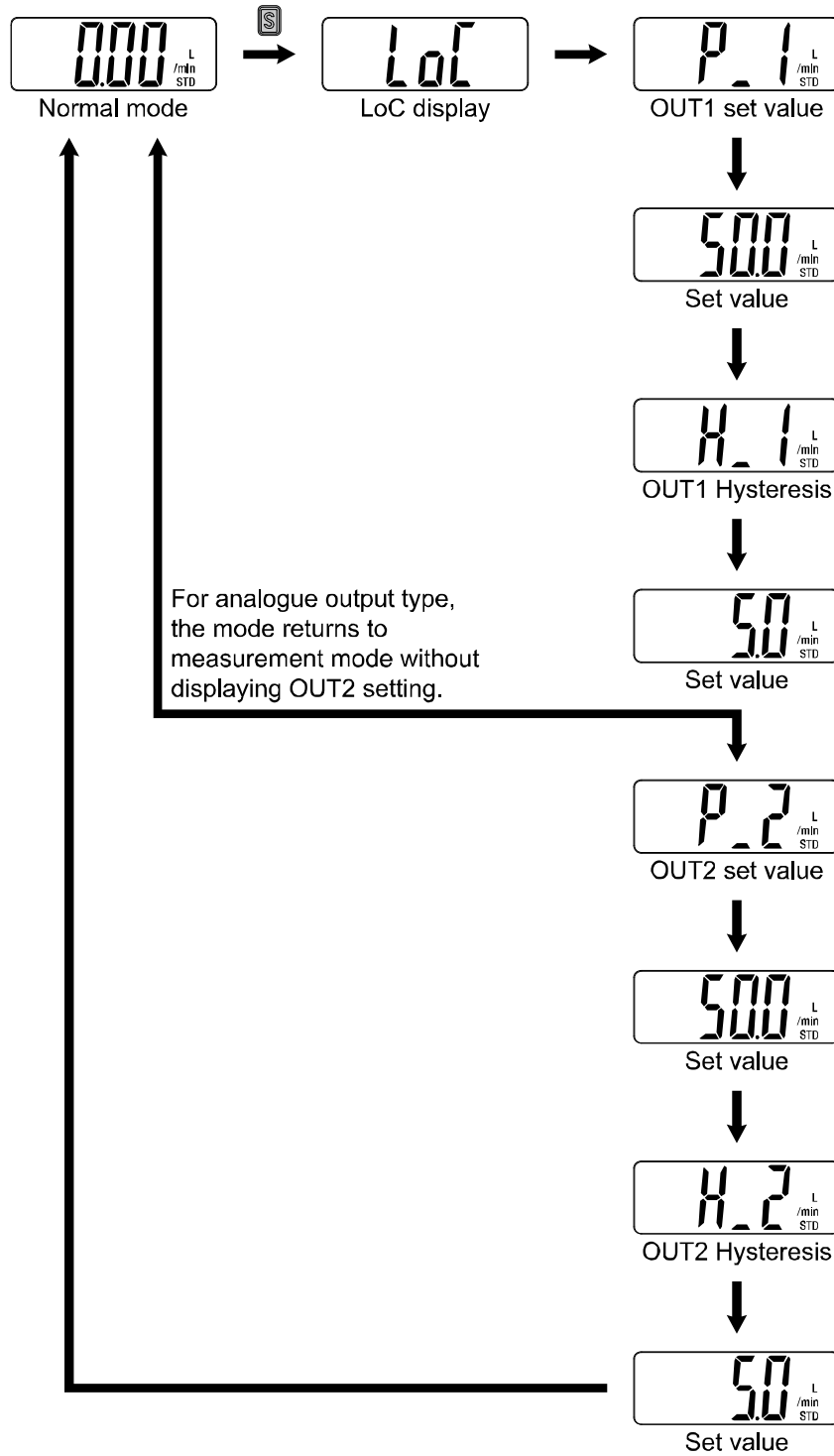

<Operation -Without security code input->

- (1) Press the SET button for 5 seconds or longer in measurement mode. When [UnL] is displayed on the display, release the button.  
(To release key-lock repeat the above operation.)

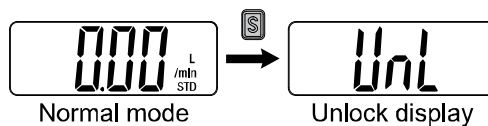

- (2) Select the key locking [LoC]/un-locking [UnLoc] with the UP or DOWN button, and press the SET button to set.

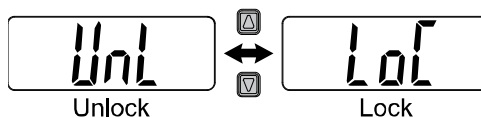

<Operation -With security code input->

### •Locking

- (1) Press the SET button for 5 seconds or longer in measurement mode. When [UnL] is displayed on the display, release the button.

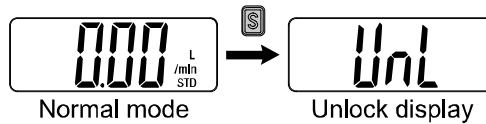

- (2) Select the key [LoC] with UP or DOWN button, and press the SET button to set.

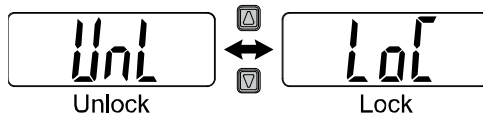

### •Unlocking

- (1) Press the SET button for 5 seconds or longer in measurement mode. When [LoC] is flashed on the display, release the button.

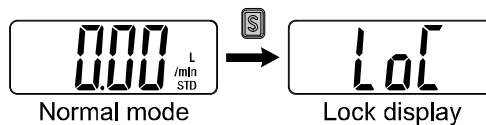

- (2) Press the UP or DOWN button to select unlock [UnL] and press the SET button. The security code is required to enter.

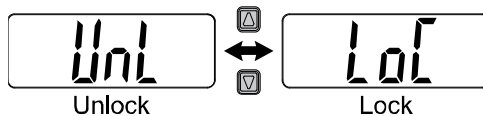

- (3) For instructions on how to enter the security code, refer to "How to input and change the security code" on page 69.



- (4) When the security code is correct, [UnL] will be displayed.  
If the security code entered is incorrect, [FAL] will be displayed, and the security code must be entered again. If the wrong security code is entered 3 times, [LoC] is displayed and the device returns to measurement mode.

- (5) Press any of the UP, SET or DOWN buttons to release the lock and return to measurement mode.

● **How to input and change the security code**

The left most digit starts flashing.

Press the UP or DOWN button to select a value.

Press the SET button to make the next digit to the right flash.

(If the SET button is pressed at the last digit, the first digit will start flashing.)

After the setting is complete, Press and hold the SET button for 1 second or longer.

(If an operation is not performed for 30 seconds during input or change of the security code, it will return to measurement mode.)

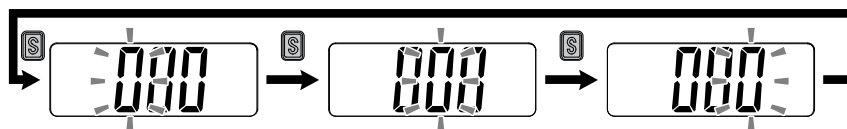

● **Zero-clear function**

The displayed value can be adjusted to zero if the flow being measured is within  $\pm 5\%$ F.S of the zero point set at the time of default settings.

(The zero clear range varies by  $\pm 1\%$ F.S. due to variation between individual products.)

When the UP and DOWN buttons are pressed simultaneously for 1 second or longer, the displayed value is cleared to "zero".

The display returns to measurement mode automatically.

## Maintenance

### **How to reset the product after a power cut or forcible de-energizing**

The setting of the product will be retained as it was before a power cut or de-energizing. The output condition is also basically recovered to that before a power cut or de-energizing, but may change depending on the operating environment.

## Forgotten the security code

If you have forgotten your security code, please contact SMC directly.

## IO-Link Specifications

### ■ Outline of IO-Link functions

#### ○ Communication function

This product can check the temperature measurement value, diagnostic information and switch output status using cyclic data communication via the IO-Link system.

#### ○ Product status monitoring function

This function monitors the product status via the IO-Link.

- Several errors (e.g. internal hardware errors) can be monitored.
- Several warnings (e.g. flow measurement error) can be detected.

#### ○ Data storage function

The Data storage function stores the IO-Link device parameter settings to the IO-Link master.

With the IO-Link data storage function, the IO-Link device can be replaced easily without re-setting the equipment construction or setting parameters

When the device parameter is set and downloaded to the device using the IO-Link setting tool, the parameter will be uploaded to the data storage in the master by the system command after download (backup instruction by the communication command).

When the device is replaced with the same type of IO-Link device due to failure, the parameter settings stored in the master are downloaded automatically, device can be operated with the parameter settings of the previous device.

Device parameter setting is applicable to 3 types of back-up levels of the master setting ("Inactive", "back-up/Restore", "Restore").

"Back-up" implies the activation of upload and "restore" implies download.

### ■ Communication specifications

IO-Link type	Device
IO-Link version	V1.1
Communication speed	COM2 (38.4 kbps)
Min. cycle time	3.4 ms
Process data length	Input Data: 6 byte, Output Data: 0 byte
On request data communication	Available
Data storage function	Available
Event function	Available



## ■ Process data

Process data is the data which is exchanged periodically between the master and device.

This product process data consists of switch output status, error diagnostics and flow measurement value.

(Refer to the table below.)

Bit offset	Item	Notes
0	OUT1 output	0: OFF 1: ON
1	OUT2 output	0: OFF 1: ON
8	Measurement diagnostics	0: Within range 1: Out of range (HHH/LLL)
14	Fixed output	0: Normal output 1: Fixed output
15	Error Diagnosis	0: Error not generated 1: Error generated
16 to 31	Flow measurement value	With sign: 16 bit

Bit offset	31	30	29	28	27	26	25	24	23	22	21	20	19	18	17	16
Item	Flow measurement value (PD)															

Bit offset	15	14	13	12	11	10	9	8	7	6	5	4	3	2	1	0
Item	Error Diagnosis	Fixed output	Reservation				Measurement diagnostics	Reservation				OUT2	OUT1			
												Switch output				

•The process data of this product is Big-Endian type.

When the transmission method of the upper communication is Little-Endian, the byte order will be changed.

Refer to the table below for the Endian type of the major upper communication.

Endian type	Upper communication protocol
Big-Endian type	Such as PROFIBUS and PROFINET
Little-Endian type	Such as EtherNet/IP, EtherCAT and CC-Link IE Field.

○Unit specification and flow measurement value (PD)

Series	Unit	Flow range	Flow value				PD value			
			Rated flow range		Display/settable range		Rated flow range		Display/settable range	
			Min.	to Max.	Min.	to Max.	A	to B	C	to D
PF2M7	L/min	1 L	0.01	to 1.0	-0.05	to 1.05	40	to 4000	-200	to 4200
		2 L	0.02	to 2.0	-0.1	to 2.1				
		5 L	0.05	to 5.0	-0.25	to 5.25				
		10 L	0.1	to 10.0	-0.5	to 10.5				
		25 L	0.3	to 25.0	-1.3	to 26.3				
		50 L	0.5	to 50.0	-2.5	to 52.5				
		100 L	1.0	to 100.0	-5.0	to 105.0				
		200 L	2.0	to 200.0	-10.0	to 210.0				
	Cfm x 10 <sup>-3</sup>	1 L	0.4	to 35.3	-1.8	to 37.1				
		2 L	0.7	to 70.6	-3.5	to 74.2				
	cfm	5 L	0.002	to 0.177	-0.009	to 0.185				
		10 L	0.004	to 0.353	-0.018	to 0.371				
		25 L	0.009	to 0.883	-0.044	to 0.927				
		50 L	0.02	to 1.77	-0.09	to 1.85				
100 L		0.04	to 3.53	-0.18	to 3.71					
200 L		0.07	to 7.06	-0.35	to 7.42					

●Relationship between flow rate and PD

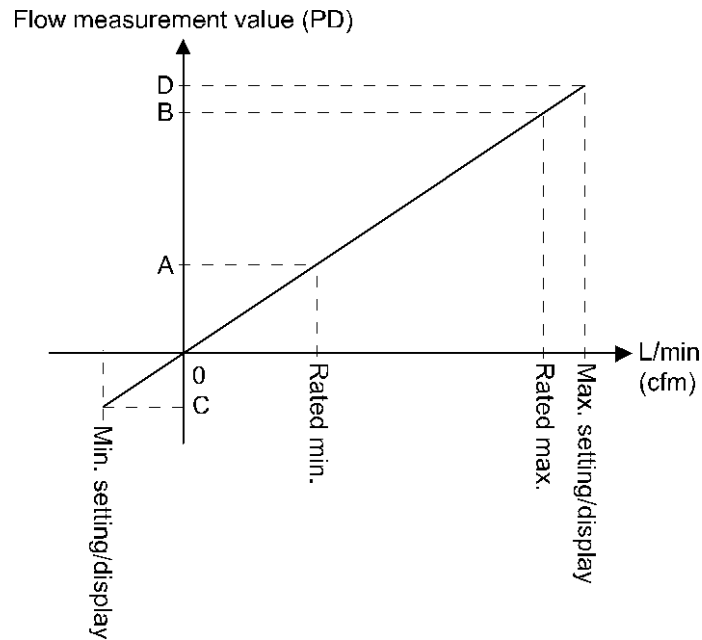

○ Conversion formula of the process data and flow measurement value

**(1) Conversion formula from the process data to the flow measurement value:**

$$Pr = a \times (PD) + b$$

**(2) Conversion formula from the flow gauge measurement value to the process data:**

$$(PD) = (Pr - b) / a$$

Pr: Flow measurement value and pressure set value

PD: Flow measurement value (process data)

a: Inclination

b: Intercept

[Inclination and intercept to the unit specification]

Series	Unit	Flow range	Inclination a	Intercept b
PF2M7	L/min	1 L	0.00025	0
		2 L	0.0005	0
		5 L	0.00125	0
		10 L	0.0025	0
		25 L	0.00625	0
		50 L	0.0125	0
		100 L	0.025	0
	Cfm x 10 <sup>-3</sup>	1 L	0.0088275	0
		2 L	0.0176575	0
	cfm	5 L	0.00004415	0
		10 L	0.000088275	0
		25 L	0.000220725	0
		50 L	0.0004415	0
		100 L	0.00088275	0

[Calculation example]

**(1) Conversion from the process data to the flow measurement value**  
(For PF2M7 series, unit L/min, flow range 25 L and PD = 3000)

$$\begin{aligned}Pr &= a \times (PD) + b \\ &= 0.00625 \times 3000 + 0 \\ &= 18.75 \text{ [L/min]}\end{aligned}$$

**(2) Conversion from the flow measurement value to the process data**  
(For PF2M7 series, unit L/min, flow range 100 L and Pr = 50 [L/min])

$$\begin{aligned}(PD) &= (Pr - b) / a \\ &= [50 - 0] / 0.025 \\ &= 2000\end{aligned}$$

## ■IO-Link parameter setting

### ○IODD file

IODD (I/O Device Description) is a definition file which provides all properties and parameters required for establishing functions and communication of the device.

IODD includes the main IODD file and a set of image files such as vendor logo, device picture and device icon.

The IODD file is shown below.

Product No.	IODD file *
PF2M7*(S)-**L*	SMC-PF2M7****L* * * *-yyyymmdd-IODD1.1

\*: "\*" indicates the product No., and the product No. applicable to each IODD file input.

\*: "yyyymmdd" indicates the file preparation date. yyyy is the year, mm is the month and dd is the date.

The IODD file can be downloaded from the SMC Web site (<https://www.smcworld.com>).

### ○Service data

The tables below indicates the parameters which can be read or written by simple access parameter (direct parameters page) and ISDU parameters which are applicable to various parameters and commands.

#### ●Direct parameters page 1

DPP1 address	Access	Parameter name	Initial value (dec)	Content
0x07	R	Vendor ID	0x0083 (131)	"SMC Corporation"
0x08				
0x09	R	Device ID	0x00016D (365)	PF2M701****L****
0x0A			0x00016E (366)	PF2M701****L2****
			0x00016F (367)	PF2M701****L3****
			0x000170 (368)	PF2M701****L4****
			0x000171 (369)	PF2M702****L****
			0x000172 (370)	PF2M702****L2****
			0x000173 (371)	PF2M702****L3****
			0x000174 (372)	PF2M702****L4****
			0x000175 (373)	PF2M705****L****
			0x000176 (374)	PF2M705****L2****
			0x000177 (375)	PF2M705****L3****
			0x000178 (376)	PF2M705****L4****
			0x000179 (377)	PF2M710****L****
			0x00017A (378)	PF2M710****L2****
			0x00017B (379)	PF2M710****L3****
			0x00017C (380)	PF2M710****L4****
			0x00017D (381)	PF2M725****L****
			0x00017E (382)	PF2M725****L2****
			0x00017F (383)	PF2M725****L3****
0x000180 (384)			PF2M725****L4****	
0x000181 (385)	PF2M750****L****			
0x000182 (386)	PF2M750****L2****			
0x000183 (387)	PF2M750****L3****			
0x000184 (388)	PF2M750****L4****			
0x000185 (389)	PF2M711****L****			
0x000186 (390)	PF2M711****L2****			
0x000187 (391)	PF2M711****L3****			
0x000188 (392)	PF2M711****L4****			
0x00023B (571)	PF2M721****L****			
0x00023C (572)	PF2M721****L2****			
0x00023D (573)	PF2M721****L3****			
0x00023E (574)	PF2M721****L4****			

●ISDU parameters

Index (dec)	Sub index	Access *1	Parameters	Initial value	Remarks
0x0002 (2)	0	W	System command	-	Refer to "System command" on page 77.
0x000C (12)	0	R/W	Device access lock	0x0000	Refer to "Device access lock parameter" on page 78.
0x0010 (16)	0	R	Vendor name	SMC Corporation	
0x0011 (17)	0	R	Vendor text	www.smcworld.com	
0x0012 (18)	0	R	Product name	Example: PF2M710x-xx-Lx-xxx	
0x0013 (19)	0	R	Product ID	Example: PF2M710x-xx-Lx-xxx	
0x0014 (20)	0	R	Product text	Flow sensor	
0x0015 (21)	0	R	Serial number	Example: "xxxxxxxx"	•Initial value is indicated as 8-digit. •16 octets fixed character string
0x0016 (22)	0	R	Hardware version	HW-Vx.y	x: Large revision number y: Small revision number
0x0017 (23)	0	R	Software version	FW-Vx.y	x: Large revision number y: Small revision number
0x0024 (36)	0	R	Device status parameter	-	Refer to "Device state parameters" on page 78.
0x0025 (37)	0	R	Device detailed state parameter	-	Refer to "Device detailed state parameter" on page 79.
0x0028 (40)	0	R	Process data input	-	The latest value of process data can be read.

\*1: R: Read, W: Write

●System command (index 2)

In the ISDU index 0x002 SystemCommand (system command), the command shown in the table below will be issued.

The button of each system command is displayed on the IO-Link setting tool (excluding "ParamDownloadStore").

Click the button to send the system command to the product.

Writable commands are shown below.

Data type: 8 bit UInteger

Value	Function definition	Description
128	Device Reset	Restarts the device
129	Application Reset	Reset of the peak/bottom value Reset of the accumulated flow value
130	Restore Factory Reset	Initialize the set value to the default value
160	Zero clear	Conduct a zero-clear function
170	Flow peak bottom Reset	Reset of peak/bottom value
190	Integrated flow Reset	Reset of the accumulated flow value

- Device access lock parameter (index 12)

The contents are as follows.

Data type: 16 bit Record

Value	Contents
0	Key lock release, DS unlock (Initial value)
2	Key lock release, DS lock
8	Key lock, DS unlock
10	Key lock, DS lock

**[Key lock]**

This function prevents the user from physically changing the setting of the flow switch (button operation is not accepted).

Even when key lock function is activated, settings can be changed by IO-Link communication.

Restoration by data storage (overwriting parameter data) can be performed.

**[Lock data storage (DS lock)]**

Locking "Data storage" will invalidate the data storage function of the flow switch.

In this case, access will be denied for backup and restoration of data storage.

- Device state parameters (index 36)

Readable device states are as follows.

Data type: 8 bit UInteger

Value	State definition	Description
0	Normal operation	-
1	Maintenance inspection required	Not available
2	Outside specification range	Outside the flow measurement range Below the flow measurement range
3	Function check	Not available
4	Failure	Internal failure of digital flow switch

- Device detail status parameters (index 37)

Detailed event contents of readable device status are as follows.

Array	Event content	Event classification		Event code
		Definition	Value	
1	Internal failure of digital flow switch	Error	0xF4	0x8D03
2	Internal failure of digital flow switch	Error	0xF4	0x8D04
3	Internal failure of digital flow switch	Error	0xF4	0x8D05
4	Internal failure of digital flow switch	Error	0xF4	0x8D01
5	Internal failure of digital flow switch	Error	0xF4	0x8D06
6	Internal failure of digital flow switch	Error	0xF4	0x8D08
7	OUT2 over current error	Error	0xF4	0x8CC0
8	Outside the accumulated flow measurement	warning	0xE4	0x8D80
9	Outside the instantaneous flow measurement	warning	0xE4	0x8C10
10	Outside the instantaneous flow measurement	warning	0xE4	0x8C30
11	Test event A	warning	0xE4	0x8CA0
12	Test event B	warning	0xE4	0x8CA1
13	Data storage upload request	notification	0x54	0xFF91



●Product individual parameters

Index		Sub index	Access *1	Parameter	Data type *2	Initial value	Data storage *3	Set value	Remarks
dec	hex								
1000	0x03E8	0	R/W	Display unit	U8	0	Y	0: L/min (L) 1: cfm (ft3)	When writing to an unsettable item, it will be rejected
1010	0x03F2	0	R/W	Display colour	U8	2	Y	0: rEd (Constantly red) 1: Grn (Constantly green) 2: 1SoG (OUT1 turns green at ON) 3: 1Sor (OUT1 turns red at ON) 4: 2SoG (OUT2 turns green at ON) 5: 2Sor (OUT2 turns red at ON)	Product screen display colour
1020	0x03FC	0	R/W	NPN/PNP switching	U8	1	Y	0: nPn 1: PnP	Setting the switch output
1030	0x0406	0	R/W	Selection of external input	U8	0	Y	0: oUt (Switch output) 1: in (Exterior input)	Selection of external input Output type "L2" only
1060	0x0424	0	R/W	Fluid	U8	0	Y	0: Air (Air) 1: Ar (Argon) 2: Co2 (Carbon dioxide)	
1070	0x042E	0	R/W	Normal condition	U8	0	Y	0: std (Standard condition) 1: nor (Normal condition)	
1210	0x04BA	1	R/W	Output operation mode	U8	0	Y	0: HYS (Hysteresis) 1: Wind (Window comparator) 2: AC (Accumulated output) 3: PLS (Accumulated pulse output) 4: Err (Error output) 5: oFF (Output OFF)	Selection of OUT1 output mode
		2	R/W	Output type	U8	0	Y	0: 1_P (Normal output) 1: 1_n (Reverse output)	Setting of OUT1 output normal and reserved output.
1220	0x04C4	1	R/W	Hysteresis setting value	S16	2000	Y	Setting range -200 to 4200	Setting of OUT1 output value (Hysteresis mode)
		2	R/W	Hysteresis	S16	200	Y	Setting range 0 to 4400	Setting of OUT1 hysteresis (Hysteresis mode)
		3	R/W	Lower limit of window comparator	S16	1200	Y	Setting range -200 to 4200	Setting of OUT1 output value (Lower limit of window comparator mode)
		4	R/W	Upper limit of window comparator	S16	2400	Y	Setting range -200 to 4200	Setting of OUT1 output value (Upper limit of window comparator mode)
		5	R/W	Window comparator hysteresis	S16	400	Y	Setting range 0 to 2200	Setting of OUT1 hysteresis (Window comparator mode)
		6	R/W	Delay time	S16	0	Y	Setting range 0 to 6000	Setting of OUT1 delay time
1300	0x0514	1	R/W	Accumulated output set value L	S16	0	Y	Setting range 0 to 9999	OUT1 uses the unit for accumulated output set value (When unit: "L" is selected)
		2	R/W	Accumulated output index L	S16	0	Y	Setting range 1, 2L range: -2 to 3 5, 10L range: -1 to 4 25, 50, 100, 200L range: 0 to 5	OUT1 uses the unit for accumulated output index value (When unit: "L" is selected)
1310	0x051E	1	R/W	Accumulated output set value ft3	S16	0	Y	Setting range 0 to 9999	OUT1 uses the unit for accumulated output set value (When unit: "ft3" is selected)
		2	R/W	Accumulated output index ft3	S16	0	Y	Setting range 1, 2, 5, 10, 25, 50L range: -2 to 3 100, 200L range: -1 to 4	OUT1 uses the unit for accumulated output set value (When unit: "ft3" is selected)

●Product individual parameters (continued)

Index		Sub index	Access *1	Parameter	Data type *2	Initial value	Data storage *3	Set value	Remarks
dec	hex								
1410	0x0582	1	R/W	Output operation mode	U8	0	Y	0: HYS (Hysteresis) 1: Wind (Window comparator) 2: AC (Accumulated output) 3: PLS (Accumulated pulse) 4: Err (Error output) 5: oFF (Output OFF)	Selection of OUT2 output mode
		2	R/W	Output type	U8	0	Y	0: 2_P (Normal output) 1: 2_n (Reverse output)	Setting of OUT2 output normal and reserved output.
1420	0x058C	1	R/W	Hysteresis set value	S16	2000	Y	Setting range -200 to 4200	Setting of OUT2 output value (Hysteresis mode)
		2	R/W	Hysteresis	S16	200	Y	Setting range 0 to 4400	Setting of OUT2 hysteresis (Hysteresis mode)
		3	R/W	Lower limit of window comparator	S16	1200	Y	Setting range -200 to 4200	Setting of OUT2 output value (Lower limit of window comparator mode)
		4	R/W	Upper limit of window comparator	S16	2400	Y	Setting range -200 to 4200	Setting of OUT2 output value (Upper limit of window comparator mode)
		5	R/W	Window comparator hysteresis	S16	400	Y	Setting range 0 to 2200	Setting of OUT2 hysteresis (Window comparator mode)
		6	R/W	Delay time	S16	0	Y	Setting range 0 to 6000	Setting of OUT2 delay time
1500	0x05DC	1	R/W	Accumulated output set value L	S16	0	Y	Setting range 0 to 9999	OUT2 uses the unit for accumulated output set value (When unit: "L" is selected)
		2	R/W	Accumulated output index L	S16	0	Y	Setting range 1, 2L range: -2 to 3 5, 10L range: -1 to 4 25, 50, 100, 200L range: 0 to 5	OUT2 uses the unit for accumulated output index value (When unit: "L" is selected)
1510	0x05E6	1	R/W	Accumulated output set value ft3	S16	0	Y	Setting range 0 to 9999	OUT2 uses the unit for accumulated output set value (When unit: "ft3" is selected)
		2	R/W	Accumulated output index ft3	S16	0	Y	Setting range 1, 2, 5, 10, 25, 50L range: -2 to 3 100, 200L range: -1 to 4	OUT2 uses the unit for accumulated output index value (When unit: "ft3" is selected)
1600	0x0640	0	R/W	Accumulated flow output direction	U8	0	Y	0: Add (Addition) 1: dEC1 (Subtraction OUT1) 2: dEC2 (Subtraction OUT2)	
1800	0x0708	0	R/W	Digital filter	U8	3	Y	0: 0.05 (sec) 1: 0.1 (sec) 2: 0.5 (sec) 3: 1.0 (sec) 4: 2.0 (sec) 5: 5.0 (sec)	
2000	0x07D0	0	R/W	Display mode	U8	0	Y	0: inS (Instantaneous flow) 1: AC (Accumulated flow) 2: ioL (IO-Link mode)	Measurement mode display screen setting
2010	0x07DA	0	R/W	Display resolution	U8	0	Y	0: 1000 resolution 1: 100 resolution	Resolution setting: only for 1 L, 10 L and 100 L

●Product individual parameters (continued)

Index		Sub index	Access *1	Parameter	Data type *2	Initial value	Data storage *3	Set value	Remarks
dec	hex								
2020	0x07E4	0	R/W	Reversed Display	U8	0	Y	0: oFF (not reversed) 1: on (reversed)	
2030	0x07EE	0	R/W	Zero cur	S8	1	Y	Setting range 0 to 10[%]	Zero cut-off range setting 1: Unit [%]
2040	0x07F8	0	R/W	Exterior input	U8	1	Y	0: oFF 1: rAC (Reset accumulation) 2: rPb (Reset peak/ bottom value)	External input setting Output type "L2" only
2100	0x0834	0	R/W	Analogue voltage output	U8	0	Y	0: 1 to 5 V 1: 0 to 10 V	Setting of analogue voltage output Output type "L3" only
2110	0x083E	1	R/W	Analogue free span	U8	0	Y	0: oFF 1: on	Analogue Free Span Function ON/OFF
		2	R/W	Analogue free span Set value	S16	4000	Y	Setting range 400 to 4200	Set value of Analogue Free Span Function ON
2200	0x0898	0	R/W	Accumulated-value holding function	U8	0	Y	0: oFF 1: 2.0min 2: 5.0min	
2400	0x0960	0	R/W	Display OFF mode	U8	0	Y	0: on 1: oFF	
2410	0x0960	1	R/W	Security code Used/Not used	U8	0	Y	0: invalid 1: valid	Security code Used/Not used
		2	R/W	Security code	S16	0	Y	Security code 0 to 999	
7000	0x1B58	0	W	Communication OUT output test	U8	-	N	0: Normal (Normal output) 1: Fixed (Fixed output)	
7010	0x1B62	0	W	Toggle output	U8	-	N	0: Flow rate 16: OUT1 17: OUT2 80: Analogue output 224: Diagnostic bit 255: Error bit	Effective only when the communication OUT output test setting is fixed.
7100	0x1BBC	0	R	Analogue output check	F32	-	N	Voltage output: 0.1 V (unit) Current output: 1 mA (unit)	The current analogue output value is returned.
8000	0x1F40	0	R	PD conversion equation : a	F32	-	N	Refer to "Inclination and intercept". (Page 74)	
8010	0x1F4A	0	R	PD conversion equation : b	F32	-	N	Refer to "Inclination and intercept". (Page 74)	
8020	0x1F54	0	R	Instantaneous flow peak value	S16	-	N	-200 to 4000	The conversion method from the communication value to the actual measurement value is the same as the method for process data.
8030	0x1F5E	0	R	Instantaneous flow bottom value	S16	-	N	-200 to 4000	
8040	0x1F68	1	R	Accumulated flow value measured value (temporary value)	S16	-	N	0 to 9999	
		2	R	Accumulated measured value (index)	S16	-	N	-2 to 5	Reply the accumulated measured value corresponding to the product range and unit selection.

\*1: "R" means Read and "W" means Write.

\*2: Refer to the table below for the symbol.

Symbol	Data type (IO-Link standard)	Data length Bit [byte]	Description
U8	UIntegerT	8[1]	Unsigned integer
U16		16[2]	
S16	IntegerT	16[2]	Signed integer
F32	Float32T	32[4]	Floating point number

\*3: "Y" indicates that the parameter setting data is saved to the master, and "N" indicates that the parameter is not saved.

\*4: Read/write to un-selectable items will be rejected depending on the product No.

## Troubleshooting

If an operation failure occurs with the product, use the chart below to find out the cause of the problem. If a cause applicable to the troubles cannot be identified and normal operation can be recovered by replacement with a new product, this indicates that the product itself was faulty. A product can be damaged by the operating environment (system configuration etc). If the product seems to be faulty, please contact SMC.

### •Faults and countermeasures

	Problem	Possible cause	Item to check	Countermeasure
Display	No Display	Incorrect wiring	Check that the brown and blue wires are connected to DC (+) and DC (-) respectively.	Correct the wiring.
		Loose connector	Check the connectors.	Correct the connector wiring.
	[H_Hi] and [H_Lo] are displayed in turn.	Peak/bottom value display mode is selected	Check if the peak value or bottom value display mode has been selected.	Refer to "Peak/bottom value display" (page 64), and remove the setting.
	Display is not stable	Foreign matter has entered the flow passage or adhered to the sensor	(1) Check if any foreign matter has entered the flow passage. (2) Check if there is foreign matter on the mesh.	Install a filter or mist separator on the IN side. If there is foreign matter on the mesh, remove it completely, taking care not to damage the product.
		Piping connected backwards	Check that the fluid flow is in the same direction as marked on the product body.	Mount the product so that the flow direction is the same as the arrow indicated on the side of the body.
		Flow is pulsing	Check if there is any supply pressure fluctuation or pressure pulsation due to the characteristics of the source compressor (or pump).	Change to a pressure source with less fluctuation or install a tank which reduces the pressure fluctuation.
		Air leakage	Check if there is air leakage in the piping.	Correct the piping.

	Problem	Possible cause	Item to check	Countermeasure
Display	Incorrect display	Foreign matter has entered the flow passage or adhered to the sensor	(1) Check if any foreign matter has entered the flow passage. (2) Check if there is foreign matter on the mesh.	Install a filter or mist separator on the IN side. If there is foreign matter on the mesh, remove it completely, taking care not to damage the product.
		Piping in the reverse direction	Check that the fluid flow is in the same direction as marked on the product body.	Mount the product so that the flow direction is the same as the arrow indicated on the side of the body.
		Incorrect unit selection *1	Check the selection of the flow unit.	Select the correct unit using the unit selection function.
		Air leakage	Check if there is air leakage in the piping.	Correct the piping.
	Flow does not start.	The flow adjustment valve is locked *2	Check the flow adjustment valve lock ring.	Loosen the lock ring before adjustment.

	Problem	Possible cause	Item to check	Countermeasure
Output	No output	Incorrect wiring	Check that the brown, blue, black and white wires are connected correctly.	Correct the wiring.
		Connector is disconnected	Check the connectors.	Correct the connector wiring.
	Output is unstable	Foreign matter has entered the flow passage or adhered to the sensor	(1) Check if any foreign matter has entered the flow passage. (2) Check if there is foreign matter on the mesh.	Install a filter or mist separator on the IN side. If there is foreign matter on the mesh, remove it completely, taking care not to damage the product.
		Piping in the reverse direction	Check that the fluid flow is in the same direction as marked on the product body.	Mount the product so that the flow direction is the same as the arrow indicated on the side of the body.
		Flow is pulsing	Check if there is any supply pressure fluctuation or pressure pulsation due to the characteristics of the source compressor (or pump).	Change to a pressure source with less fluctuation or install a tank which reduces the pressure fluctuation.
		Air leakage	Check if there is air leakage in the piping.	Correct the piping.
Hysteresis value too low	Check the hysteresis set value.	Increase the hysteresis set value.		
Button	No reaction when the buttons are pressed	The keys are locked	Check if [Loc] is displayed when the buttons are pressed.	Release the key-lock function. (page 66)
Flow adjustment valve	The flow adjustment valve fails to adjust the flow *2	The flow adjustment valve is locked	Check the lock ring on the flow adjustment valve.	Loosen the lock ring, and then adjust the flow adjustment valve.



\*1: Product with unit selection function

\*2: The table lists the parts when a flow adjusting valve is included.

## ■ Error indication

Error Name	Error displayed	Description	Measures
Instantaneous flow error		Flow exceeding the upper limit of the set flow range is applied.	Reduce the flow.
		Flow exceeding the lower limit of the set flow range is applied.	Ensure the flow is in the correct direction.
OUT1 over current error		The load current applied to the switch output has exceeded the maximum value. (OUT1)	Turn the power off and remove the cause of the over current. Then turn the power on again.
OUT2 over current error		The load current applied to the switch output has exceeded the maximum value. (OUT2)	Turn the power off and remove the cause of the over current. Then turn the power on again.
Zero clear error		During zero clear operation, pressure greater than $\pm 5\%$ F.S. is applied. (The mode is returned to measurement mode automatically 1 second later).	Retry the zero clear operation without applying fluid.
System error		An internal data error has occurred.	Turn the power off and turn it on again.

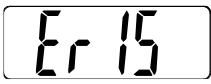

Error Name	Error displayed	Description	Measures
Accumulated flow error *1	 Accumulated flow is displayed (flashing)	The accumulated flow has exceeded the accumulated flow range. (For accumulated increment)	Reset the accumulated flow. (Press the UP and DOWN buttons simultaneously for <u>1 second or longer</u> ) (page 65)
	 Accumulated flow is displayed (flashing)	The accumulated flow has reached the set accumulated flow. (For accumulated decrement)	
Version does not match		Version of master and IO-Link does not match. Mismatch because master version is 1.0.	Align the master IO-Link version to the device.

\*1: A decimal point will be displayed depending on the flow range or measurement unit setting.

\*: If the error cannot be reset after the above measures are taken, or errors other than above are displayed, please contact SMC.

# Specifications

Model		PF2M701	PF2M702	PF2M705	PF2M710	PF2M725	PF2M750	PF2M711	PF2M721	
Fluid	Applicable fluid *1	Dry air, N <sub>2</sub> , Ar, CO <sub>2</sub> (ISO8573-1 1.1.2 to 1.6.2)								
	Fluid temperature range	0 to 50 °C								
Flow rate spec.	Detection method	Thermal type (main flow type)			Thermal type (branch flow type)					
	Rated flow range [L/min]	Dry air, N <sub>2</sub> , Ar	0.01 to 1	0.02 to 2	0.05 to 5	0.1 to 10	0.3 to 25	0.5 to 50	1 to 100	2 to 200
		CO <sub>2</sub>	0.01 to 0.5	0.02 to 1	0.05 to 2.5	0.1 to 5	0.3 to 12.5	0.5 to 25	1 to 50	2 to 100
	Set flow range	Instantaneous flow [L/min]	-0.05 to 1.05	-0.1 to 2.1	-0.25 to 5.25	-0.5 to 10.5	-1.3 to 26.3	-2.5 to 52.5	-5 to 105	-10 to 210
		Accumulated flow [L]	0.00 to 9999999.99		0.0 to 99999999.9		0 to 999999999			
	Min. setting unit	Instantaneous flow [L/min]	0.001	0.01			0.1			1
		Accumulated flow [L]	0.01		0.1		1			
	Accumulated volume per pulse [L/pulse]	0.01			0.1			1		
Accumulated value hold *2	Select from 2 minutes and 5 minutes									
Pressure spec.	Operating pressure range	-0.1 to 0.75 MPa								
	Rated pressure range *3	-0.07 to 0.75 MPa								
	Proof pressure	1.0 MPa								
	Pressure loss	Refer to the pressure loss graph.								
	Pressure characteristics	±5%F.S. ±1 digit (0.35 MPa standard)								
Electric spec.	Power supply voltage *4	Switch output device	12 to 24 VDC ±10%							
		IO-Link device	18 to 30 VDC ±10%							
	Current consumption	35 mA or less								
	Protection	Polarity protection								
Accuracy *5	Display accuracy	±3%F.S. ±1 digit								
	Analogue output accuracy	±3%F.S.								
	Repeatability	±1%F.S. ±1 digit (±2% F.S. ±1 digit when digital filter is set to 0.05 s)								
	Temperature characteristics	±3%F.S. ±1 digit (15 to 35 °C: 25 °C standard) ±5%F.S. ±1 digit (0 to 50 °C: 25 °C standard)								

Model		PF2M701	PF2M702	PF2M705	PF2M710	PF2M725	PF2M750	PF2M711	PF2M721	
Switch output	Output type	NPN or PNP open collector								
	Output mode	Select from hysteresis mode, window comparator mode, accumulated output mode, accumulated pulse output mode, error output and switch output OFF								
	Switch operation	Select from normal output and reversed output								
	Maximum load current	80 mA								
	Maximum applied voltage	28 VDC (NPN only)								
	Internal voltage drop	Standard value	NPN: 1 V or less (Load current 80 mA) PNP: 1.5 V or less (Load current 80 mA)							
		IO-Link compatible product	1.5 V or less (Load current 80 mA)							
	Response time * <sup>6</sup>	50 ms or less								
	Delay time * <sup>7</sup>	0 to 0.10 s (0.01 s increment), 0.1 to 1.0 s (0.1 s increment), 1 to 10 s (1 s increment) Select from 20 s, 30 s, 40 s, 50 s, 60 s								
	Hysteresis * <sup>8</sup>	Variable								
Protection	Short circuit protection									
Analogue output * <sup>9</sup>	Output type	Voltage output: 1 to 5 V (0 to 10 V can be selected, only when the power supply voltage is 24 VDC) * <sup>10</sup> , Current output 4 to 20 mA								
	Impedance	Voltage output	Output impedance approx. 1 kΩ							
		Current output	Max. load impedance Power supply voltage 24 V: 600 Ω Power supply voltage 12 V: 300 Ω							
	Response time * <sup>6</sup>	50 ms ±40%								
Display	Reference condition * <sup>11</sup>	Select from normal condition (STD) and standard condition (NOR)								
	Display mode	Select from instantaneous flow and accumulated flow								
	Unit * <sup>12</sup>	Instantaneous flow	L/min, cfm							
		Accumulated flow	L, ft <sup>3</sup>							
	Displayable range	Instantaneous flow [L/min]	-0.05 to 1.05	-0.1 to 2.1	-0.25 to 5.25	-0.5 to 10.5	-1.3 to 26.3	-2.5 to 52.5	-5 to 105	-10 to 210
		Zero cut-off range	0 to ±10%F.S. (selected for every 1%F.S. of max. rated flow rate)							
		Accumulated flow [L] * <sup>13</sup>	0.00 to 9999999.99		0.0 to 99999999.9		0 to 999999999			
	Display	Display type: LCD, Display colour: Red, green, Display digit: 7-segment, 4 digits								
Operation LED	LED is ON when switch output is ON, OUT1/OUT2: Orange									
Digital filter * <sup>14</sup>	Select from 0.05 s, 0.1 s, 0.5 s, 1 s, 2 s and 5 s									
Environmental resistance	Enclosure	IP40								
	Withstand voltage	1000 VAC, 1 min. between terminals and housing								
	Insulation resistance	50 MΩ or longer (with 500 VDC) between terminals and housing								
	Operating temperature range	Operation: 0 to 50 °C, Storage: -10 to 60 °C (no freezing or condensation)								
	Operating humidity range	Operation, Storage: 35 to 85%R.H. (no freezing or condensation)								
Standards	CE/UKCA marked, UL									
Piping * <sup>15</sup>	Piping specification	One-touch fitting	C4 (φ4)/C6 (φ6)			C6 (φ6)/N7 (φ1/4")		C8 (φ8)/N7 (φ1/4")		
		Screw fitting (Rc/NPT/G)	01 (Rc1/8)/N1 (NPT1/8)/F1 (G1/8)					02 (Rc1/4)/N2 (NPT1/4)/F2 (G1/4)		
	Port direction	Straight, Rear								

Model		PF2M701	PF2M702	PF2M705	PF2M710	PF2M725	PF2M750	PF2M711	PF2M721	
Material fluid contact parts		PPS, PBT, FKM, SUS304, brass (Electroless nickel plating), Si, Au, GE4F								
Weight	Body	One-touch fitting	Straight: 40 g Rear: 55 g					Straight: 48 g Rear: 63 g		
		Screw fitting	Straight: 60 g Rear: 75 g					Straight: 72 g (G1/4: 117 g) Rear: 87 g (G1/4: 132 g)		
	Flow adjustment valve	-		+34 g						
	Lead wire									+35 g
	Bracket									+20 g
	Panel mount adapter									+15 g
	DIN rail mounting bracket									+65 g

- \*1: Refer to the recommended pneumatic circuit.
- \*2: When using the Accumulated flow hold function, calculate the product life according to the operating conditions, and use the product within its life. The limit of the number times the memory can be written to is 3.7 million times. If the product is operated 24 hours per day, the life will be as follows.
- Data stored every 5 minutes: 5 minutes x 3.7 million cycles = 18.5 million minutes = 35 years
  - Data stored every 2 minutes: 2 minutes x 3.7 million cycles = 7.4 million minutes = 14 years
- \*3: Load describes the pressure on the IN side (upstream side).
- \*4: When multiple products are installed closely, the upper limit of the power supply voltage is 24 VDC.
- \*5: The accuracy value is based on dry air as a fluid. For other fluids, it is a reference value.
- \*6: Value when the digital filter is set at 0.05 sec.
- \*7: The time can be set from when the instantaneous flow reaches the set value, to when the switch output actually begins working.
- \*8: If the applied voltage fluctuates around the set value, the width for setting more than the fluctuating width needs to be set. Otherwise, chattering will occur.
- \*9: This function is available when the model includes an analogue output.
- \*10: When selecting 0 to 10 V, refer to the analogue output graph for the allowable load current.
- \*11: Standard condition (STD): 20 [°C], 101.3 [kPa] (Absolute pressure), 65 [%R.H.]  
(Flow rate in the specification is the value at standard condition)  
Normal condition (NOR): 0 [°C], 101.3 [kPa] (Absolute pressure), 0 [%R.H.]
- \*12: This setting is only available for models with the units selection function.
- \*13: Power value is displayed for accumulated flow. The first 4 digits of the measurement value are always displayed.
- \*14: Set the time for digital filter to the sensor input. The response time indicates when the set value is 90% in relation to the step input.
- \*15: Check the precautions for One-touch fitting before use. When the piping condition is changed, for example due to piping on the back of the product, use a general purpose fitting (KQ#L series).  
Some piping conditions may have negative effects on the flow accuracy.
- \*16: Any products with tiny scratches, smears, or display colour variation or brightness which does not affect the performance are verified as conforming products.

Communication (During IO-Link mode)

IO-Link type	Device
IO-Link version	V1.1
Communication speed	COM2 (38.4 kbps)
Min. cycle time	3.4 ms
Process data length	Input Data: 4 byte, Output Data: 0 byte
On request data communication	Available
Data storage function	Available
Event function	Available
Vendor ID	131 (0x0083)
Device ID	Refer to direct parameters page 1 (page 76)

Cable specification: Lead wire with connector (ZS-33-D(M))

Items		Specifications
Conductor	Nominal cross section area	AWG26
Insulator	Outside diameter	Approx.1.00 mm
	Colours	Brown, White, Black, Blue
Sheath	Outer diameter	$\phi 3.5$ +0.10 -0.25

## ■ Characteristics data

### ● Flow rate/Analogue output

	A	B <sup>*2</sup>		C
		PF2M701/702/705/710/750/711/721	PF2M725	
Voltage output (1 to 5 V)	1 V	1.04 V	1.05 V	5 V
Current output (4 to 20 mA)	4 mA	4.16 mA	4.19 mA	20 mA

	E	F		G
		PF2M701/702/705/710/750/711/721	PF2M725	
Voltage output (0 to 10 V) <sup>*1</sup>	0 V	0.10 V	0.12 V	10 V

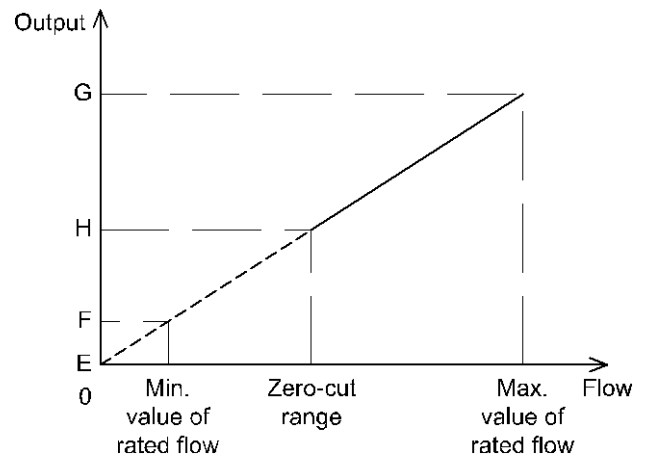
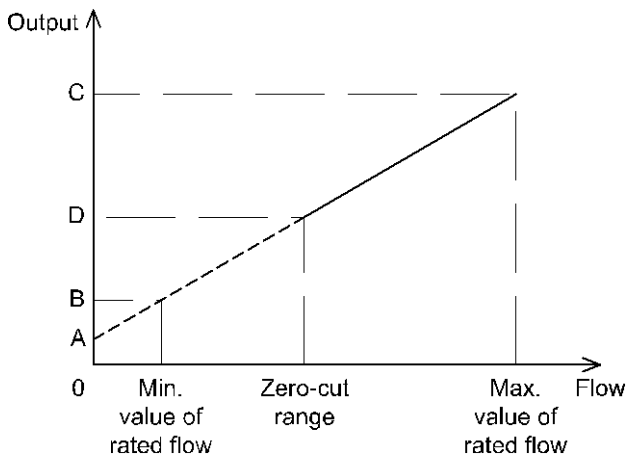

\*1: The analogue output current from the connected equipment should be 20  $\mu$ A or less when selecting 0 to 10 V.

When more than 20  $\mu$ A current flows, it is possible that the accuracy will not be satisfied below 0.5 V.

\*2: D or H changes based on the setting of the zero cut-off function.

When the zero cut-off function is set to "0", the display starts from 0 L/min. In conditions other than horizontal installation and 0.35 MPa supply pressure, the output may not be 0 L/min.

●Flow adjustment needle revolution - Flow characteristics (reference data)

PF2M705 (5 L/min)

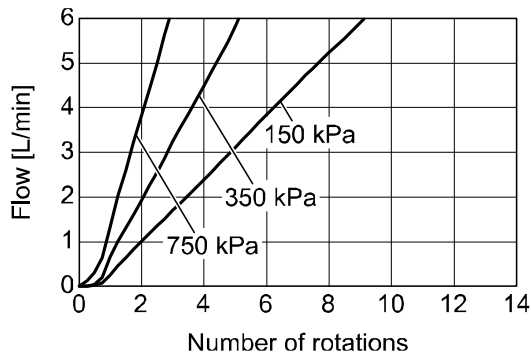

PF2M710 (10 L/min)

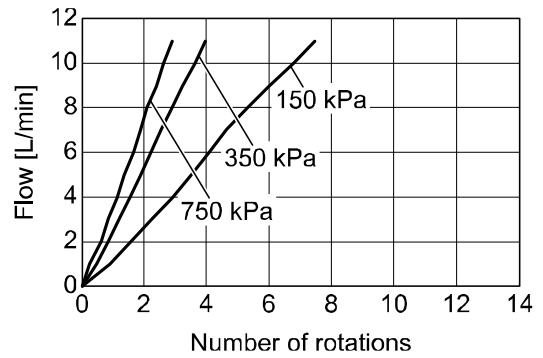

PF2M725 (25 L/min)

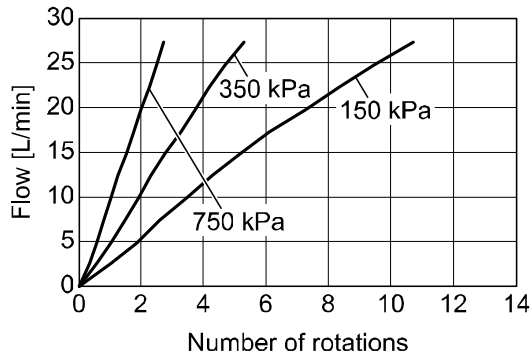

PF2M750 (50 L/min)

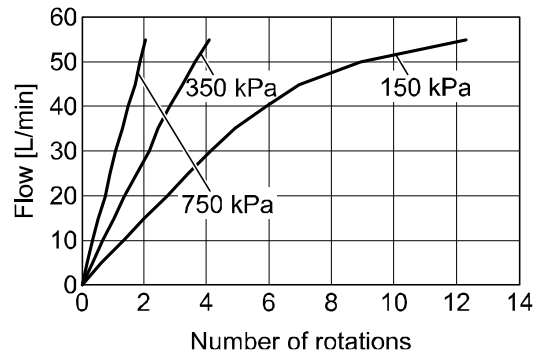

PF2M711 (100 L/min)

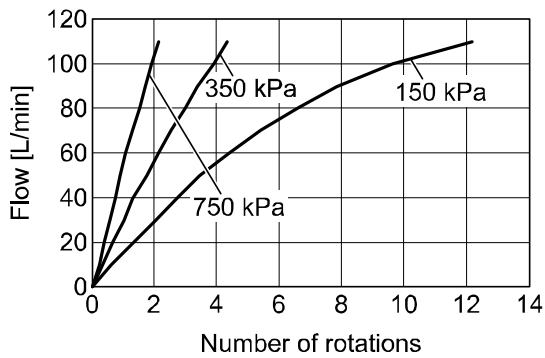

PF2M721 (200 L/min)

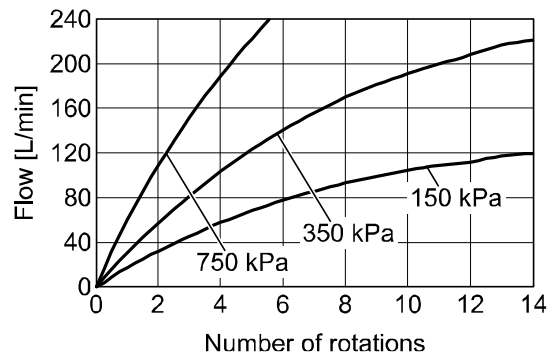

● Pressure loss (reference data): Without flow adjustment valve

PF2M701 (1 L/min)

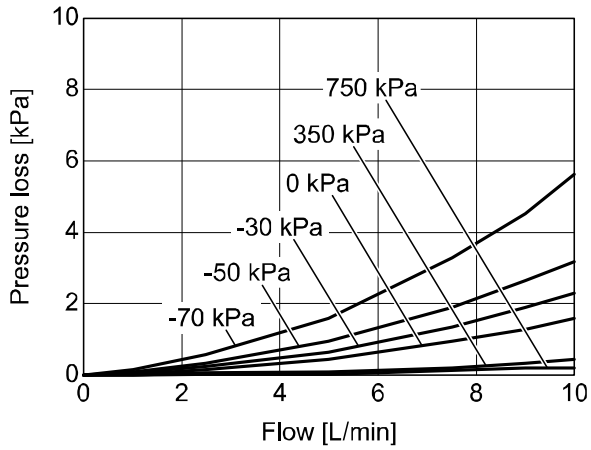

PF2M702 (2 L/min)

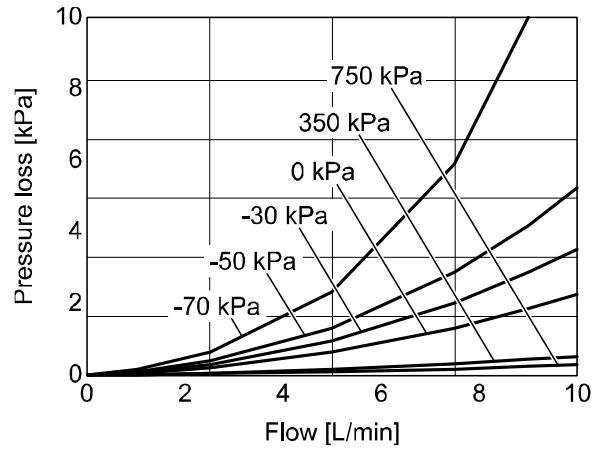

PF2M705 (5 L/min)

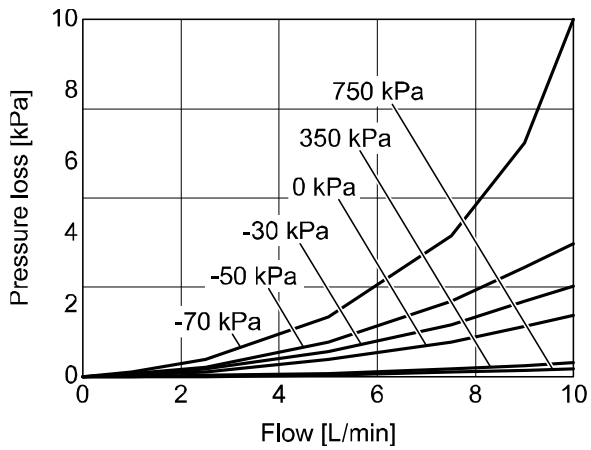

PF2M710 (10 L/min)

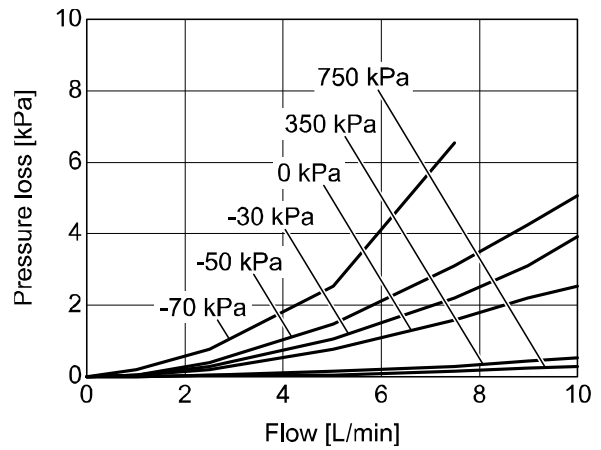



PF2M725 (25 L/min)

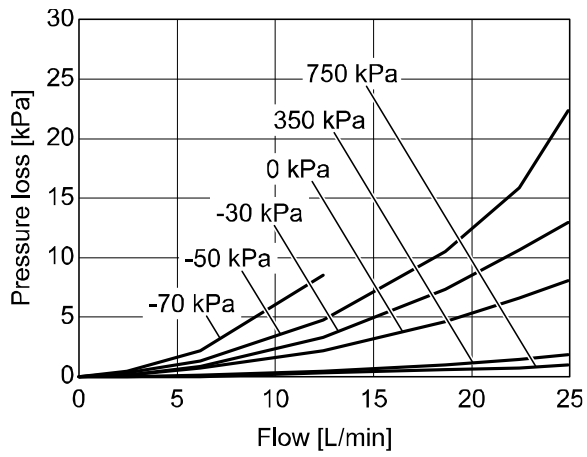

PF2M750 (50 L/min)

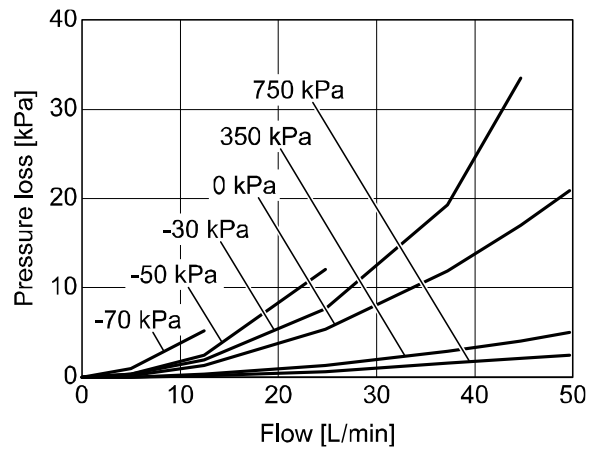

PF2M711 (100 L/min)

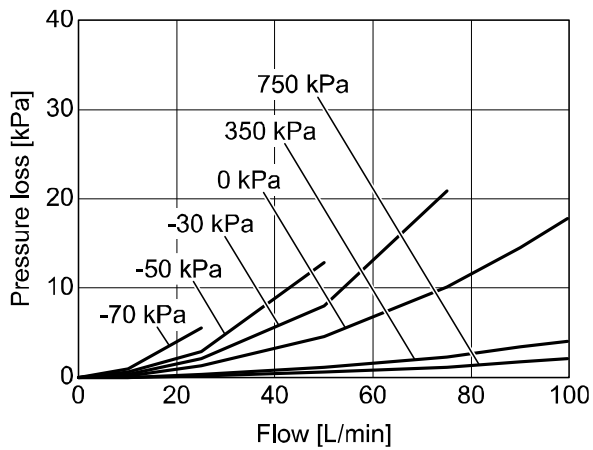

PF2M721 (200 L/min)

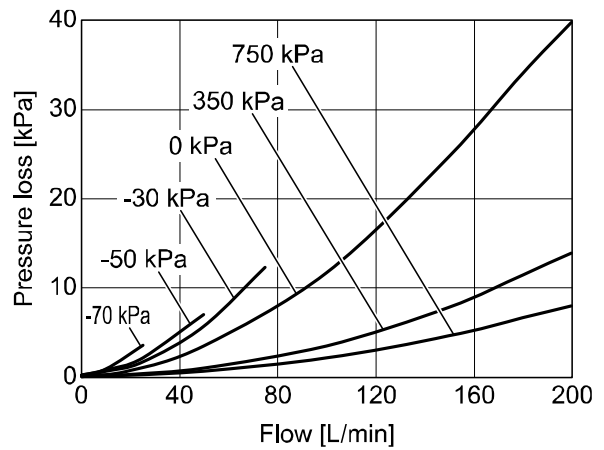

- Flow characteristic at negative pressure (reference data)

When the PF2M series is used with negative pressure (-70 to 0 kPa), the measurable range (warranty range of the specifications including pressure characteristics) varies depending on the flow range. Select the flow range referring to the chart below.

PF2M701 (1 L/min)

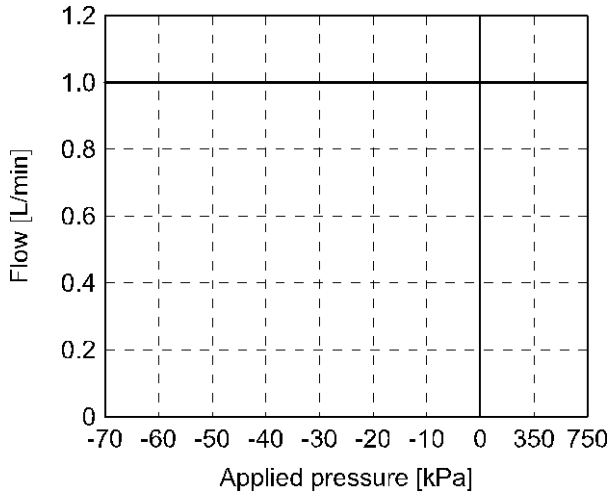

PF2M702 (2 L/min)

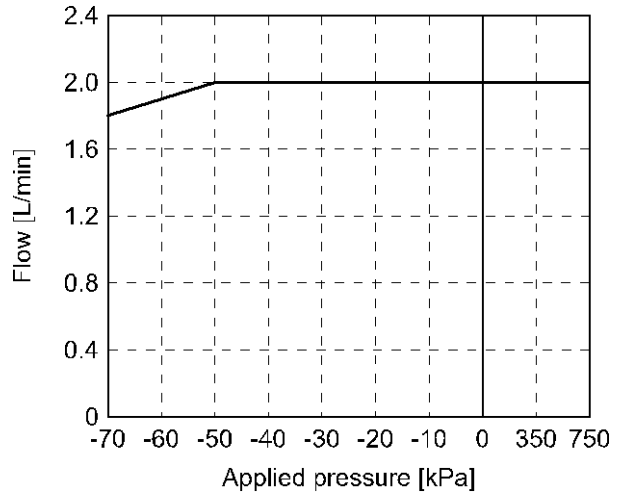

PF2M705 (5 L/min)

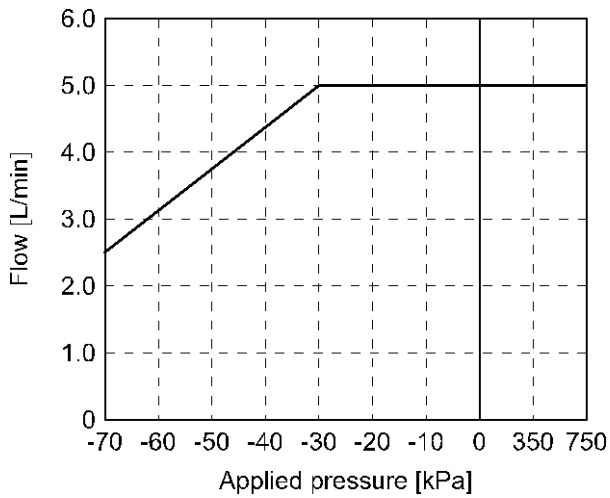

PF2M710 (10 L/min)

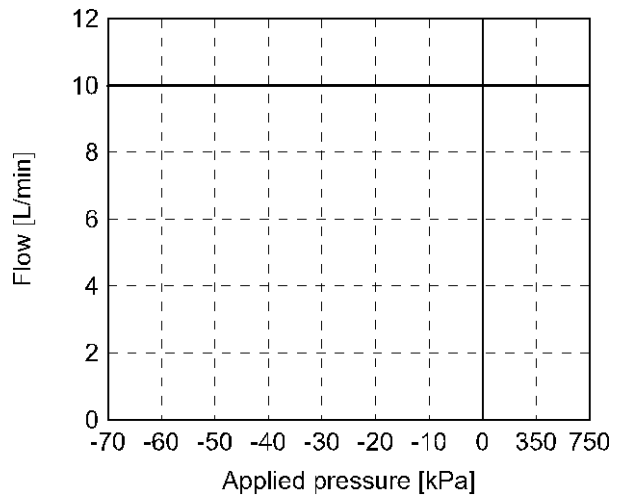

PF2M725 (25 L/min)

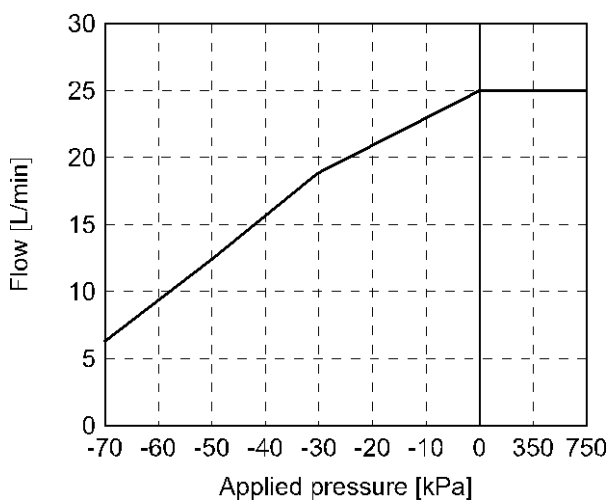

PF2M750 (50 L/min)

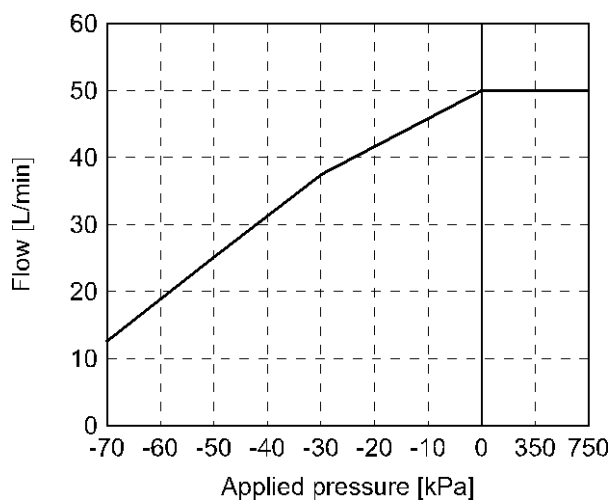

PF2M711 (100 L/min)

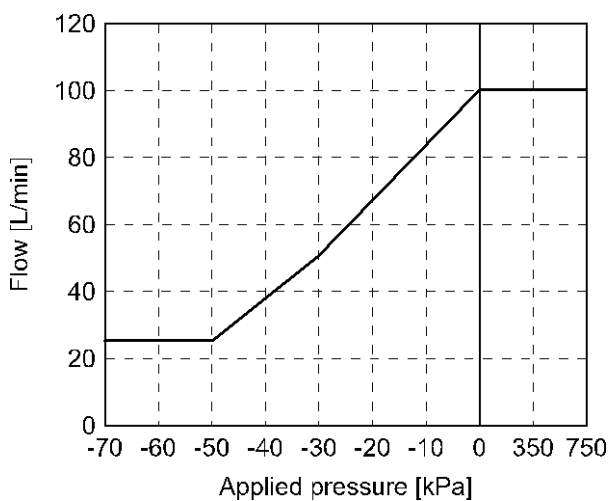

PF2M721 (200 L/min)

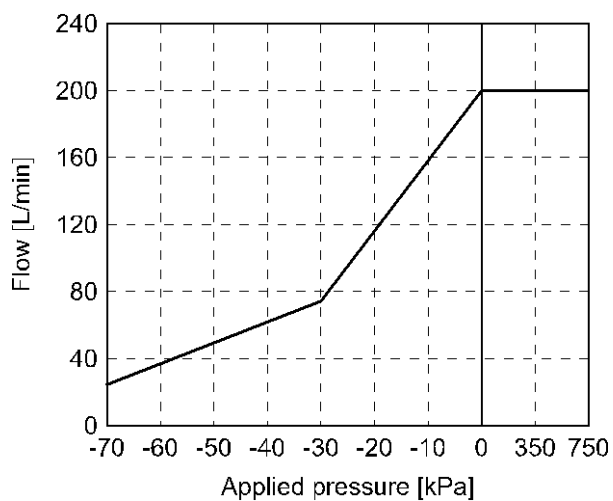

## ■Dimensions

PF2M7#-C4/C6/C8/N7(-L)

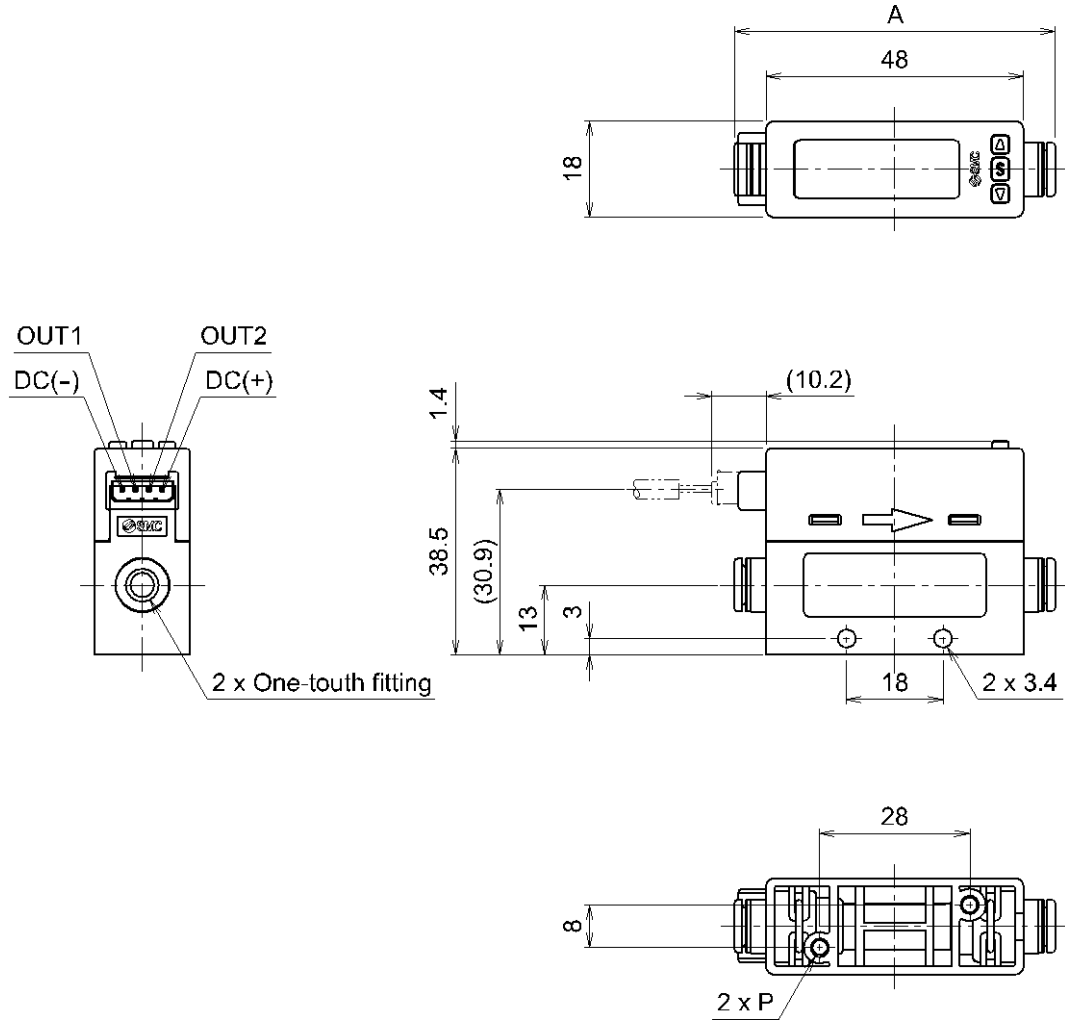

(mm)

Model	A	P
PF2M701/702/705/710-C4(-L)	59.1	φ2.8 depth 8.4
PF2M701/702/705/710/725/750-C6(-L)	59.9	φ2.8 depth 8.4
PF2M725/750-N7(-L)	67.5	φ2.8 depth 8.4
PF2M711/721-C8(-L)	68	φ2.8 depth 6.2
PF2M711/721-N7(-L)	64.6	φ2.8 depth 6.2

PF2M#L-C4/C6/C8/N7(-L)

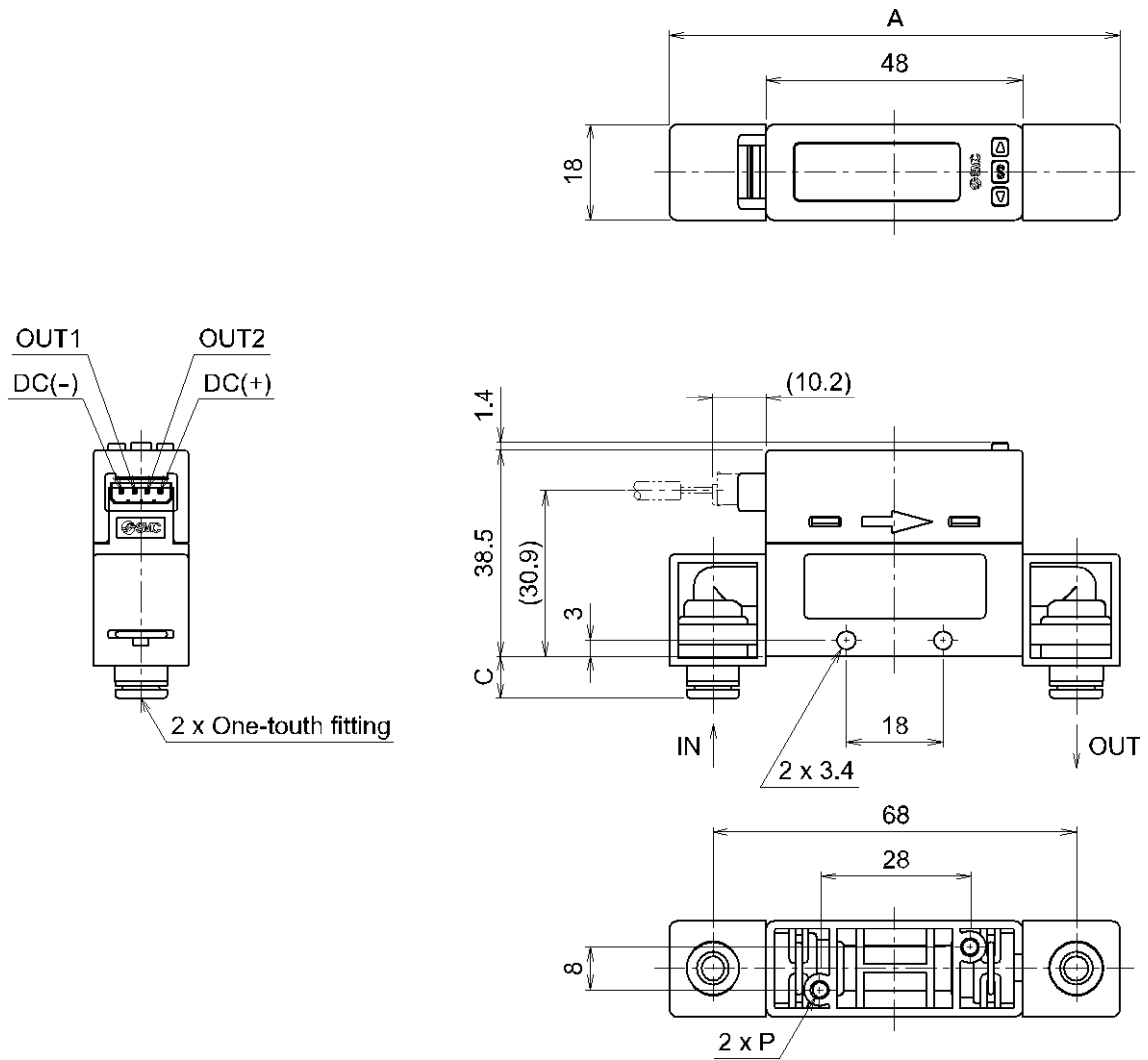

(mm)

Model	A	C	P
PF2M701/702/705/710L-C4(-L)	84.4	7.6	φ2.8 depth 8.4
PF2M701/702/705/710/725/750L-C6(-L)	84.4	8	φ2.8 depth 8.4
PF2M725/750L-N7(-L)	84.4	11.8	φ2.8 depth 8.4
PF2M711/721L-C8(-L)	88	12	φ2.8 depth 6.2
PF2M711/721L-N7(-L)	88	10.3	φ2.8 depth 6.2

PF2M7#-#1/2(-L)

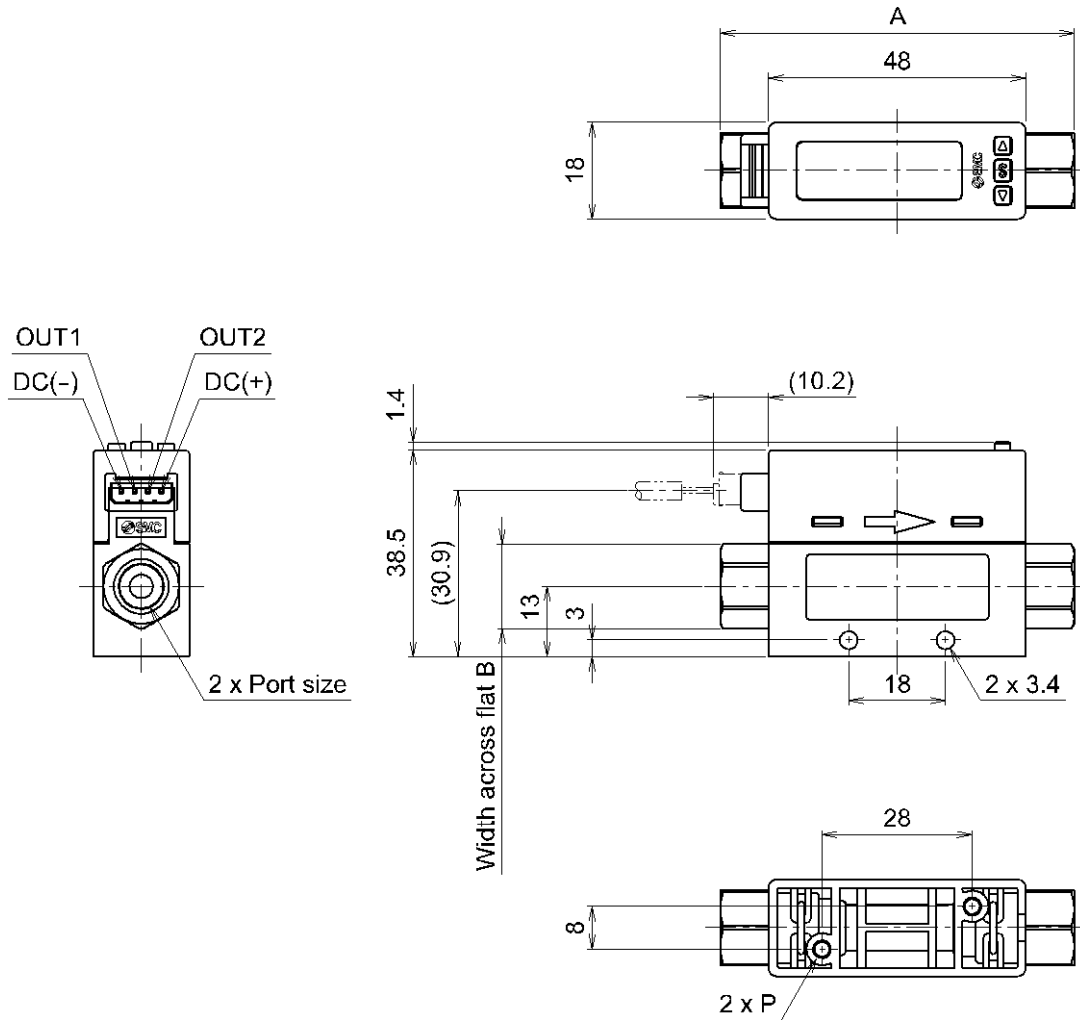

(mm)

Model	A	B	P
PF2M701/702/705/710/725/750-01(-L)	66	14	φ2.8 depth 8.4
PF2M701/702/705/710/725/750-N1(-L)	68	14	φ2.8 depth 8.4
PF2M701/702/705/710/725/750-F1(-L)	70	14	φ2.8 depth 8.4
PF2M711/721-02(-L)	70	17	φ2.8 depth 6.2
PF2M711/721-N2(-L)	70	17	φ2.8 depth 6.2
PF2M711/721-F2(-L)	78	21	φ2.8 depth 6.2

PF2M7#L-#1/2(-L)

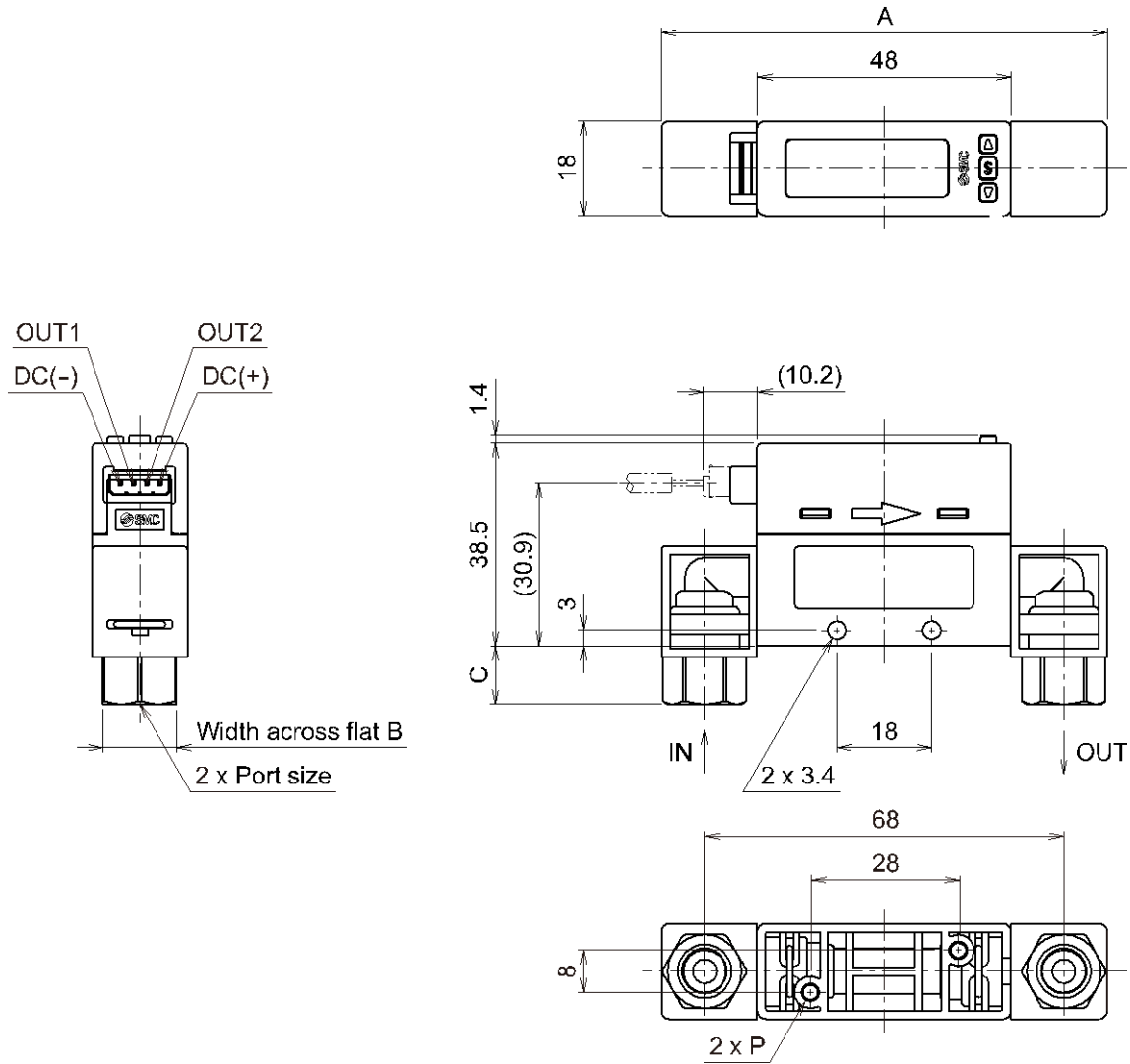

(mm)

Model	A	C	B	P
PF2M701/702/705/710/725/750L-01(-L)	84.4	11	14	φ2.8 depth 8.4
PF2M701/702/705/710/725/750L-N1(-L)	84.4	12	14	φ2.8 depth 8.4
PF2M701/702/705/710/725/750L-F1(-L)	84.4	13	14	φ2.8 depth 8.4
PF2M711/721L-01(-L)	88	13	17	φ2.8 depth 6.2
PF2M711/721L-N1(-L)	88	13	17	φ2.8 depth 6.2
PF2M711/721L-F1(-L)	88	17	21	φ2.8 depth 6.2

PF2M7#S-C4/C6/C8/N7(-L)

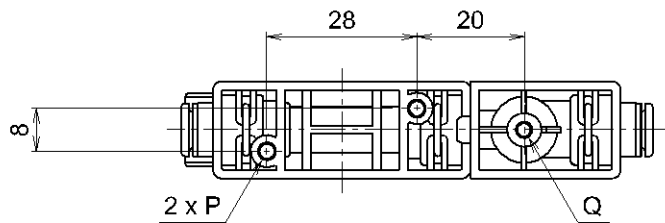
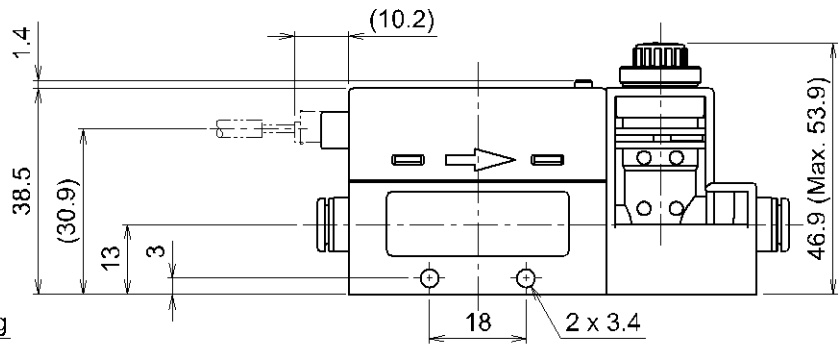
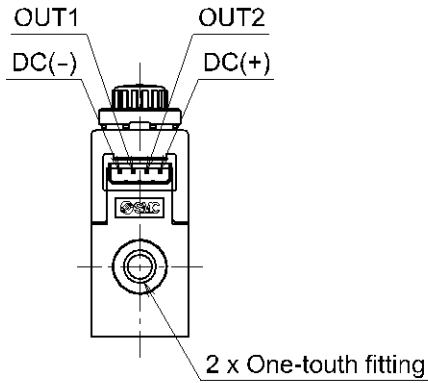
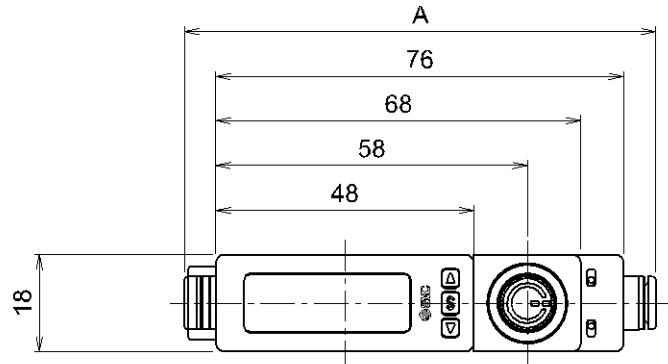

(mm)

Model	A	P	Q
PF2M705/710S-C4(-L)	87.1	φ2.8 depth 8.4	φ2.5 depth 6
PF2M705/710/725/750S-C6(-L)	87.9	φ2.8 depth 8.4	φ2.5 depth 6
PF2M725/750S-N7(-L)	95.5	φ2.8 depth 8.4	φ2.5 depth 6
PF2M711/721S-C8(-L)	96	φ2.8 depth 6.2	φ2.5 depth 5
PF2M711/721S-N7(-L)	92.6	φ2.8 depth 6.2	φ2.5 depth 5



PF2M7#W-C4/C6/C8/N7(-L)

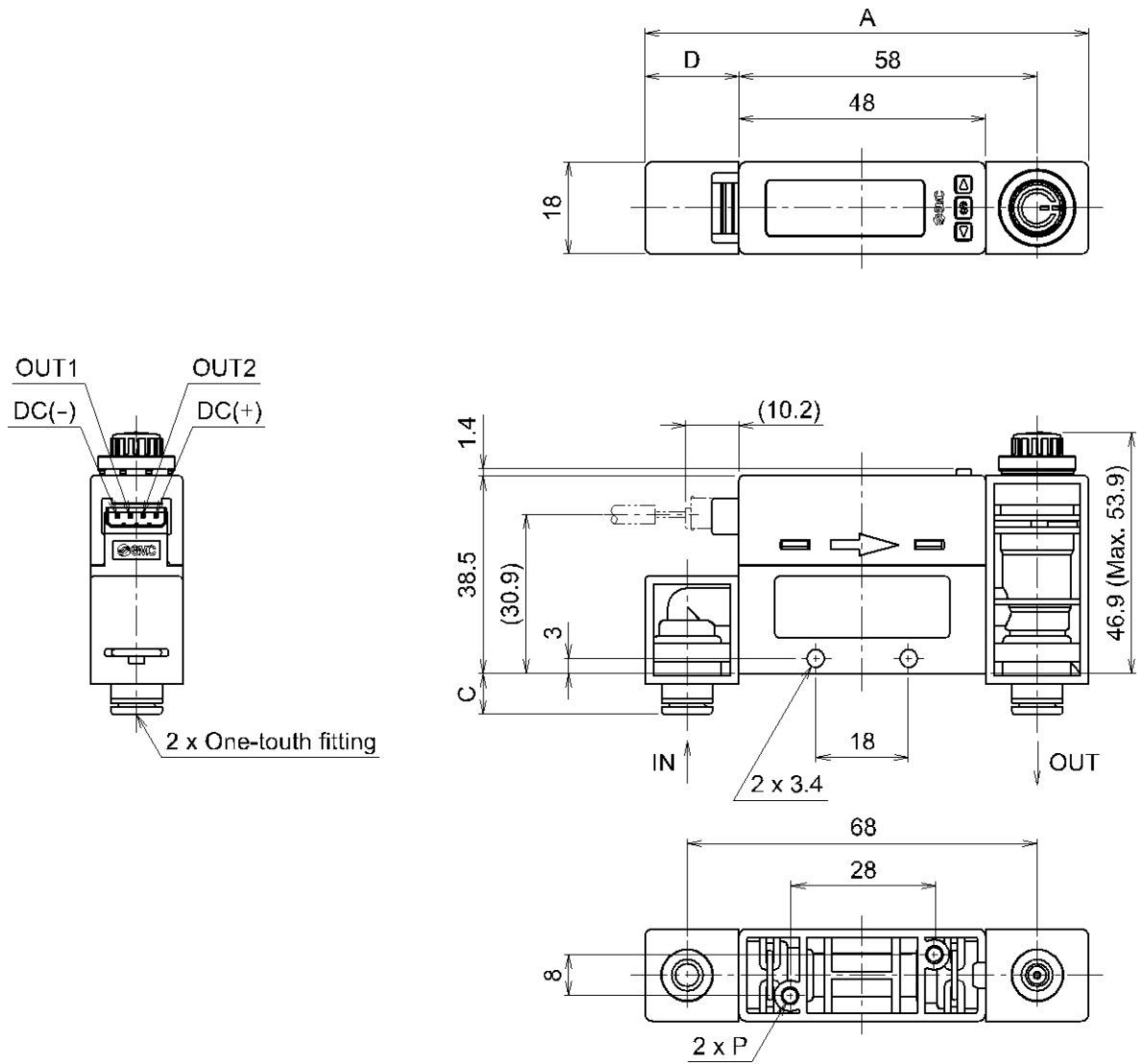

(mm)

Model	A	C	D	P
PF2M705/710W-C4(-L)	86.2	7.6	18.2	φ2.8 depth 8.4
PF2M705/710/725/750W-C6(-L)	86.2	8	18.2	φ2.8 depth 8.4
PF2M725/750W-N7(-L)	86.2	11.8	18.2	φ2.8 depth 8.4
PF2M711/721W-C8(-L)	88	12	20	φ2.8 depth 6.2
PF2M711/721W-N7(-L)	88	10.3	20	φ2.8 depth 6.2

PF2M7#S-#1/2(-L)

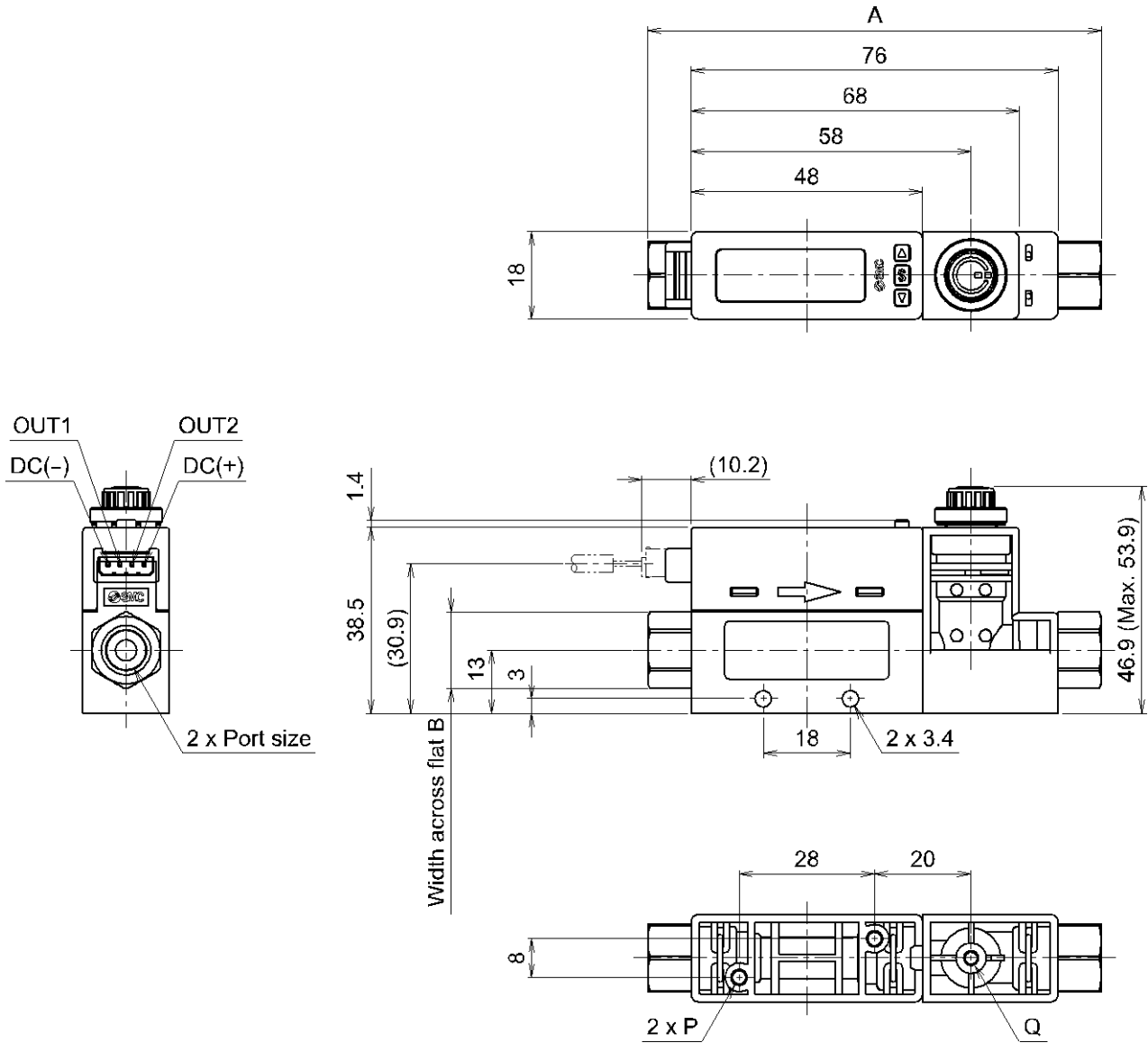

(mm)

Model	A	B	P	Q
PF2M705/710/725/750S-01(-L)	94	14	φ2.8 depth 8.4	φ2.5 depth 6
PF2M705/710/725/750S-N1(-L)	96	14	φ2.8 depth 8.4	φ2.5 depth 6
PF2M705/710/725/750S-F1(-L)	98	14	φ2.8 depth 8.4	φ2.5 depth 6
PF2M711/721S-02(-L)	98	17	φ2.8 depth 6.2	φ2.5 depth 5
PF2M711/721S-N2(-L)	98	17	φ2.8 depth 6.2	φ2.5 depth 5
PF2M711/721S-F2(-L)	106	21	φ2.8 depth 6.2	φ2.5 depth 5

PF2M7#W-#1/2(-L)

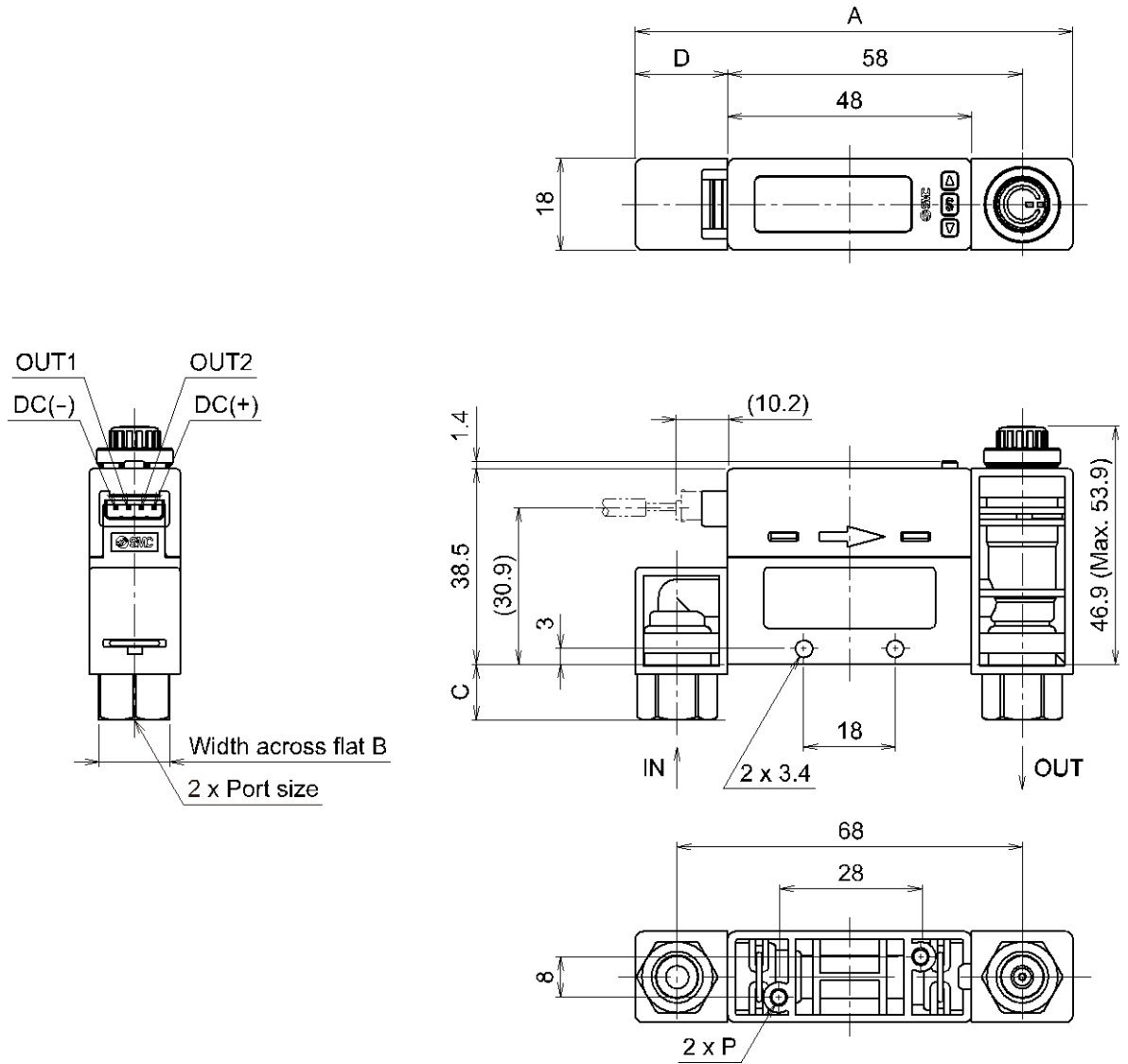

(mm)

Model	A	C	B	D	P
PF2M705/710/725/750W-01(-L)	86.2	11	14	18.2	φ2.8 depth 8.4
PF2M705/710/725/750W-N1(-L)	86.2	12	14	18.2	φ2.8 depth 8.4
PF2M705/710/725/750W-F1(-L)	86.2	13	14	18.2	φ2.8 depth 8.4
PF2M711/721W-01(-L)	88	13	17	20	φ2.8 depth 6.2
PF2M711/721W-N1(-L)	88	13	17	20	φ2.8 depth 6.2
PF2M711/721W-F1(-L)	88	17	21	20	φ2.8 depth 6.2

### Panel cut-out dimensions

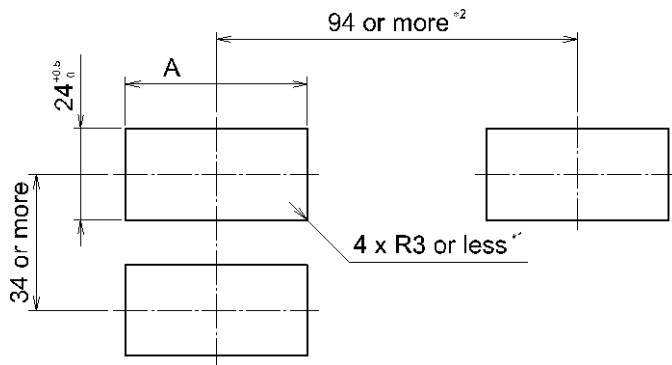

Flow adjustment valve	A
None	$54^{+0.5}_0$
With flow adjustment valve	$74^{+0.5}_0$

\*: Suitable for panel thickness of 1 to 3.2 mm.

\*1: If a bend (R) is used, limit it to R3 or less.

\*2: The value shows the minimum pitch when rear piping is selected in the port direction.

In case of the straight type, the product mounting location on the panel should be decided based on the tubing length.

### Bracket (ZS-33-M)

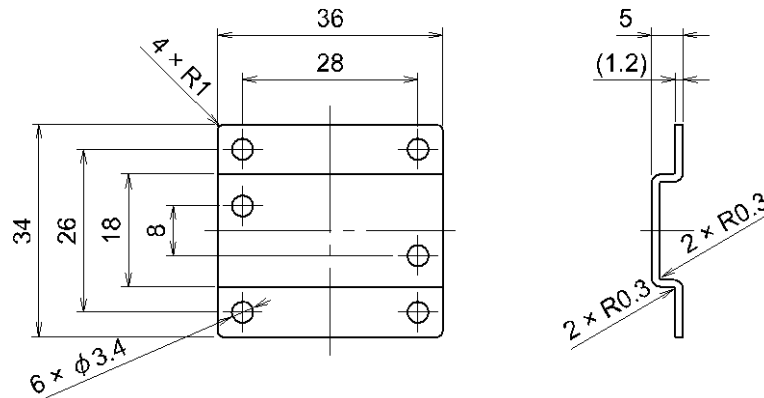

### Bracket (ZS-33-MS)

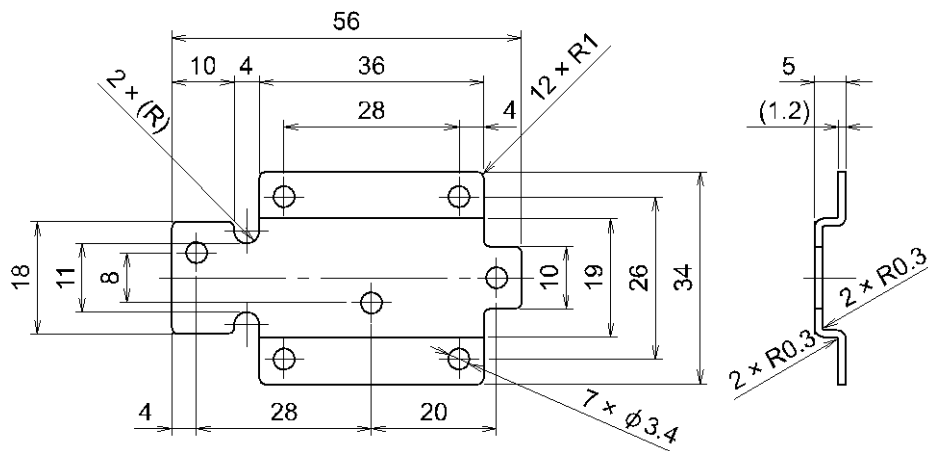

Lead wire and connector (ZS-33-D)

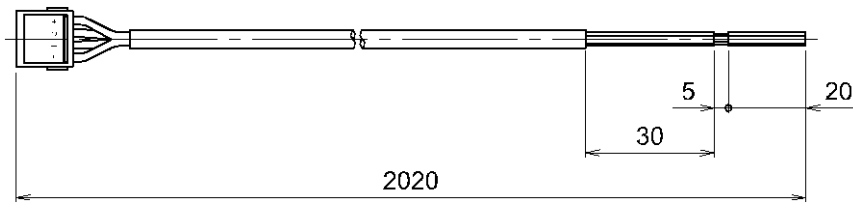

M12 conversion lead wire (ZS-33-DM)

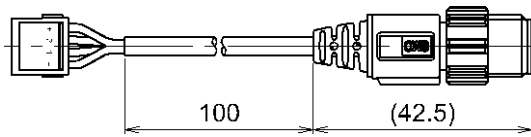

Connector cover (ZS-33-F)

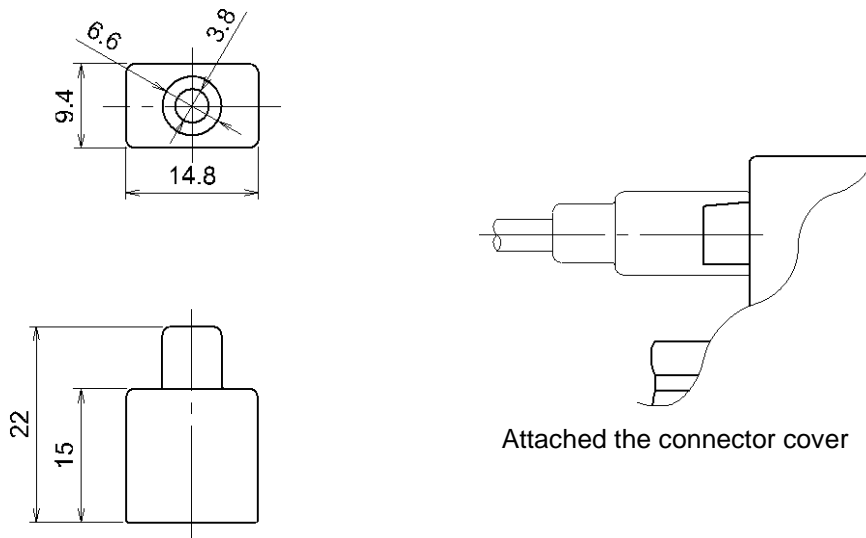

#### Revision history

A: Contents are added. [July 2019]  
B: Contents are added. [January 2020]  
C: Contents are added. [April 2021]  
D: Contents revised in several places. [July 2021]  
E: Contents revised in several places.  
[August 2022]

## SMC Corporation

4-14-1, Sotokanda, Chiyoda-ku, Tokyo 101-0021 JAPAN

Tel: + 81 3 5207 8249 Fax: +81 3 5298 5362

URL <https://www.smcworld.com>

---

Note: Specifications are subject to change without prior notice and any obligation on the part of the manufacturer.

© 2020-2022 SMC Corporation All Rights Reserved

