



Electronic Pressure Switch Operation Manual

Product Name : Electronic Pressure Switch

Model : ZSE2/ISE2(L) Series

Electronic Pressure Switch Operation Manual

Thank you for purchasing SMC Electronic Pressure Switch Series ZSE2/ISE2(L).
Read this operation manual to use this product properly.

SMC CORPORATION P 5025-20

< Before Operation > Observe the safety instructions below since they are crucial for safety.

⚠ Warning, Caution and Danger

文書No. PS* *-OMC0007

Handling

- Do not drop or hit the product, or apply excessive impact (980 m/s^2) to the product. Even if switch case body is not broken, internal parts may be broken, and malfunction could be the result.
- Tensile strength of lead is 49N (5kgf). Tension over this value will cause failure. Hold the body for handling.
- Do not put wire in pressure port. Pressure sensor will be damaged, and abnormal operation will be the result.

Environment

- Do not use this pressure switch in a location where water or oil splashes since this is an open type.
- This pressure switch is not an explosion proof type. Do not use this switch in atmosphere containing explosive gases since explosion may occur.

Wiring

- Check wire color and terminal number before wiring since wrong wiring will lead to breakage, failure or malfunction of the switch.
- Wiring that applies repeated bending stress or tensile stress will result in breakage of wire.
- Wire so that they will be no insulating failure (such as mixing with other circuit, ground fault, insulating failure between terminals, etc.). Overcurrent in switch may break the switch.
- Separate Power source line from other power lines. Control circuit with switch may malfunction due to noise.
- Do not shortcircuit load. Switch will be broken instantly due to overcurrent. Care must be taken not to replace the power source line (brown) by output line (black).

Design and Selection

- Use the product with proper power supply voltage. Voltage out of specifications will cause fire or electric shock.
- Do not apply load more than maximum load capacity. It may result in switch breakage or shorter life.
- Do not apply load that generates surge voltage. Although circuit in output section has surge protection, repeated application may break switch. When directly operating surge generating load such as relay and solenoid valve, use surge absorption element built-in type.
- When equipment/apparatus (electromagnetic type lifter, high frequency induction furnace, motor, etc.) exists near pressure switch, internal circuit element may deteriorate or break. Take some measures for surge source in addition to avoid mixing with other lines.
- Observe setting pressure range and operating pressure range. Pressure out of specifications will cause failure. Use over withstanding pressure will break switch.
- Corrosive and inflammable gases or fluids are not applicable.

Maintenance and Check

- Check pressure switch regularly for normal operation since safety may not be secured due to unexpected malfunction or improper operation.
- When this product is used in interlock circuit, multiplies interlock circuit in preparation for failure. In addition check it regularly for normal operation.

1. Specifications

Model	ZSE2	ISE2L	ISE2
	For vacuum	For low press.	For high press.
Operating/setting pressure range	0 to -101 kPa	0 to 100kPa	0 to 1 MPa
Withstand pressure	500kPa		1.5 MPa
Fluid	Air, Non-corrosive gases		
Power supply voltage	12 to 24VDC $\pm 10\%$, Ripple (P-P) 10% or less		
Current consumption	17mA or less (@ Output ON)		
Response time	5 ms or less		
Repeatability	$\pm 1\%$ F.S. or less		
Environment	Enclosure IP40		
	Operating temp.range Operation : 0 to 60 °C , Storage : -10 to 60 °C (No condensation or freezing)		
	Operating humidity range Operation · Storage : 35 to 85 %RH (No condensation)		
	Vibration proof 10 to 500Hz, smaller one of 1.5mm or 98m/s ² double amplitude, two hours each in direction of X, Y and Z respectively (De-energizing)		
Impact proof	980m/s ² , three times each in direction of X, Y and Z respectively		
Temp. characteristic	$\pm 3\%$ F.S. or less (Standard :25 °C)		
Withstand voltage	1000VAC, 1minute (between lead block and case)		
Insulation resistance	50M Ω or more (@ 500VDC M) (between lead block and case)		
Port size	01 : R(PT)1/8, M5 \times 0.8 0X,0XY : w/Suction filter (ZX ejector mounting type)		T1 : NPTF1/8, M5 \times 0.8 0R : Base mount type(ZR ejector mounting type)
Mass (weight)	35g (incl. 0.6m lead)		

Output Specifications

Model	- 15	- 55
Output	NPN open collector, 30V, 30mA	PNP open collector, 80mA
Hysteresis	3% F.S. or less (Fixed)	
Setting Point	1 point	
Indicator	Illuminate @ON (Red)	

2. Internal Circuit and Wiring Example

ZSE2/ISE2(L) - □□ - 15

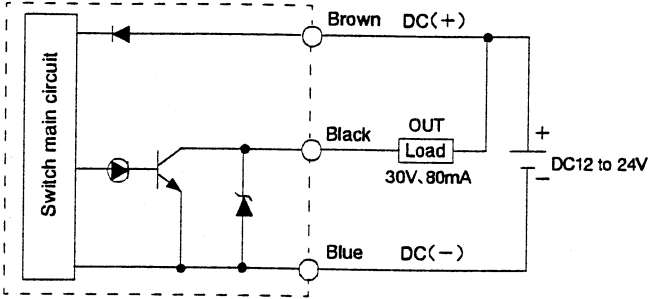

ZSE2/ISE2(L) - □□ - 55

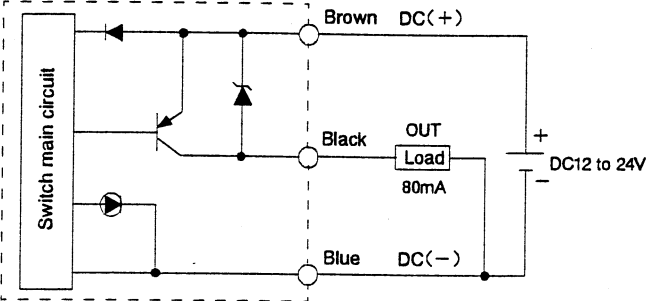

Brown lead : Connect to DC power (+) terminal to operate switch main circuit.

Blue lead : Connect to power GND terminal.

Black lead : Connect load (sequence controller input, relay, etc.)

3. Switch Mounting

Apply spanner to the attachment part (metal) of the switch when mounting switch. Do not apply spanner to the resin part. It will break the switch. Switch tightening torque range is 7 to 9 N·m (70 to 90 kgf·cm). When tightening over this torque range, mounting screws, brackets and switch may be broken. When tightening below this torque range, switch may be loosened. After installation, repair or modification, apply air and electricity for appropriate operation and leakage tests to check for correct mounting.

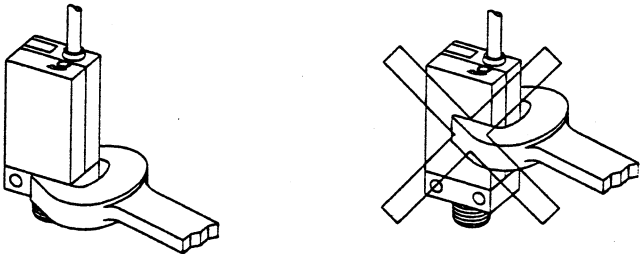

4. Pressure Setting

- Set ON pressure with pressure setting trimmer. Pressure increase or high vacuum setting in clockwise rotation.
- Hysteresis is fixed (3%F.S. or less).
- For setting, use small screw driver that fits for the trimmer groove and turn it lightly. After contacting stoppers on both sides, do not turn it anymore. If trimmer is broken, adjustment will be impossible.

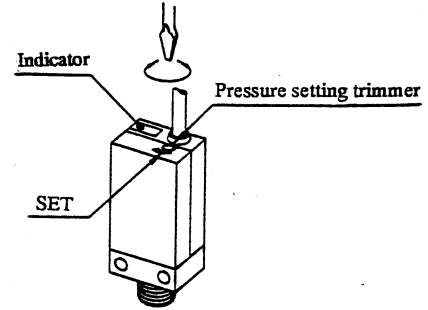

• Pressure Setting Procedures

- ① Supply pressure to switch for setting.
- ② While turning pressure setting trimmer, find a point where switch changes from ON to OFF.
- ③ While turning pressure setting trimmer counterclockwise from that point, find a point where switch turns ON.
- ④ Exhaust pressure from switch to check it turns OFF.
- ⑤ If switch turns ON and OFF stably by changing supply pressure to switch, setting is completed.
- ⑥ If switch does not turn ON and OFF stably, turn pressure setting trimmer counterclockwise and change pressures to check for stable turning ON and OFF of the switch.