



Operation Manual

PRODUCT NAME

Vacuum gripper

MODEL / Series / Product Number

ZXP7*11-***-X1***

ZXP7*12-***-X1***

The outward appearance showed on this manual is an example of the vacuum gripper with suction cups which is indicated by the product number: ZXP7A(11,12)-ZPB25JS-X1*. Refer to the suction cup catalog for the detail of other applicable suction cups.

SMC Corporation

Contents

Safety instructions.....	2
1. Parts included in the package	6
1.1. In case of ZXP7*11	6
1.2. In case of ZXP7*12	7
2. Names of Parts of the Product	8
2.1. In case of ZXP7*11	8
2.2. In case of ZXP7*12	9
3. Specifications	10
3.1. Specifications	10
3.2. Flow rate / Exhaust characteristics	11
3.3. How to calculate theoretical lifting force	12
3.4. How to order	13
4. Mounting.....	14
4.1. Mounting	14
4.2. Wiring	16
4.2.1. In case of ZXP7*11	16
4.2.2. In case of ZXP7*12	17
4.2.3. Wiring example to robot controller (common to NPN/PNP)	18
4.3. Piping	19
4.4. YASKAWA plug & play kit	20
4.4.1. Installing YASKAWA plug & play kit	20
4.4.2. YASKAWA plug & play kit - Tool Presets	25
4.4.3. YASKAWA plug & play kit - Utility Window	26
4.4.4. YASKAWA plug & play kit - Vacuum Gripper Integration Window	27
5. Dimensions.....	31
5.1. Vacuum gripper	31
5.1.1. In case of ZXP7*11	31
5.1.2. In case of ZXP7*12	32
5.2. Center of gravity	33
5.2.1. In case of ZXP7*11 (ZXP7A11-ZPB25JN-X1)	33
5.2.2. In case of ZXP7*12 (ZXP7A12-ZPB25JN-X1)	35
5.3. Suction cup with adapter	37
6. How to change the number of cups.....	39
6.1 Change to 1 cup (with flange)	39
6.2 Change to 1 cup (without flange)	40
6.3 Change to 2 cups	41
7. Maintenance	42
7.1. Maintenance for vacuum gripper	42
7.2. Maintenance for suction cup	43
8. Precautions.....	44
8.1 Air supply	44
8.2 Vacuum gripper precautions	44
8.3 Suction cup precautions	46
9. Trouble shooting.....	49



Safety Instructions

These safety instructions are intended to prevent hazardous situations and/or equipment damage. These instructions indicate the level of potential hazard with the labels of “Caution,” “Warning” or “Danger.” They are all important notes for safety and must be followed in addition to International Standards (ISO/IEC)*1), and other safety regulations.

*1) ISO 4414: Pneumatic fluid power -- General rules relating to systems.

ISO 4413: Hydraulic fluid power -- General rules relating to systems.

IEC 60204-1: Safety of machinery -- Electrical equipment of machines .(Part 1: General requirements)

ISO 10218: Manipulating industrial robots -Safety.

etc.



Caution

Caution indicates a hazard with a low level of risk which, if not avoided, could result in minor or moderate injury.



Warning

Warning indicates a hazard with a medium level of risk which, if not avoided, could result in death or serious injury.



Danger

Danger indicates a hazard with a high level of risk which, if not avoided, will result in death or serious injury.

Warning

1. The compatibility of the product is the responsibility of the person who designs the equipment or decides its specifications.

Since the product specified here is used under various operating conditions, its compatibility with specific equipment must be decided by the person who designs the equipment or decides its specifications based on necessary analysis and test results.

The expected performance and safety assurance of the equipment will be the responsibility of the person who has determined its compatibility with the product.

This person should also continuously review all specifications of the product referring to its latest catalog information, with a view to giving due consideration to any possibility of equipment failure when configuring the equipment.

2. Only personnel with appropriate training should operate machinery and equipment.

The product specified here may become unsafe if handled incorrectly.

The assembly, operation and maintenance of machines or equipment including our products must be performed by an operator who is appropriately trained and experienced.

3. Do not service or attempt to remove product and machinery/equipment until safety is confirmed.

1. The inspection and maintenance of machinery/equipment should only be performed after measures to prevent falling or runaway of the driven objects have been confirmed.

2. When the product is to be removed, confirm that the safety measures as mentioned above are implemented and the power from any appropriate source is cut, and read and understand the specific product precautions of all relevant products carefully.

3. Before machinery/equipment is restarted, take measures to prevent unexpected operation and malfunction.

4. Contact SMC beforehand and take special consideration of safety measures if the product is to be used in any of the following conditions.

1. Conditions and environments outside of the given specifications, or use outdoors or in a place exposed to direct sunlight.

2. Installation on equipment in conjunction with atomic energy, railways, air navigation, space, shipping, vehicles, military, medical treatment, combustion and recreation, or equipment in contact with food and beverages, emergency stop circuits, clutch and brake circuits in press applications, safety equipment or other applications unsuitable for the standard specifications described in the product catalog.

3. An application which could have negative effects on people, property, or animals requiring special safety analysis.

4. Use in an interlock circuit, which requires the provision of double interlock for possible failure by using a mechanical protective function, and periodical checks to confirm proper operation.



Safety Instructions

Caution

The product is provided for use in manufacturing industries.

The product herein described is basically provided for peaceful use in manufacturing industries. If considering using the product in other industries, consult SMC beforehand and exchange specifications or a contract if necessary. If anything is unclear, contact your nearest sales branch.

Limited warranty and Disclaimer/Compliance Requirements

The product used is subject to the following “Limited warranty and Disclaimer” and “Compliance Requirements”.

Read and accept them before using the product.

Limited warranty and Disclaimer

1. The warranty period of the product is 1 year in service or 1.5 years after the product is delivered, whichever is first.*2)

Also, the product may have specified durability, running distance or replacement parts. Please consult your nearest sales branch.

2. For any failure or damage reported within the warranty period which is clearly our responsibility, a replacement product or necessary parts will be provided.

This limited warranty applies only to our product independently, and not to any other damage incurred due to the failure of the product.

3. Prior to using SMC products, please read and understand the warranty terms and disclaimers noted in the specified catalog for the particular products.

***2) Suction cups are excluded from this 1 year warranty.**

A suction cup is a consumable part, so it is warranted for a year after it is delivered.

Also, even within the warranty period, the wear of a product due to the use of the suction cup or failure due to the deterioration of rubber material are not covered by the limited warranty.

Compliance Requirements

1. The use of SMC products with production equipment for the manufacture of weapons of mass destruction(WMD) or any other weapon is strictly prohibited.

2. The exports of SMC products or technology from one country to another are governed by the relevant security laws and regulation of the countries involved in the transaction. Prior to the shipment of a SMC product to another country, assure that all local rules governing that export are known and followed.

Caution

SMC products are not intended for use as instruments for legal metrology.

Measurement instruments that SMC manufactures or sells have not been qualified by type approval tests relevant to the metrology (measurement) laws of each country.

Therefore, SMC products cannot be used for business or certification ordained by the metrology (measurement) laws of each country.

■ Explanation of Symbols

Symbol	Definition
	Things you must not do. Instructions are provided as a drawing or sentence next to the symbol.
	Things you must do Instructions are provided as a drawing or sentence next to the symbol.



■ Operator

1. This Operation Manual is intended for those who have knowledge of machinery using pneumatic equipment, and have sufficient knowledge of assembly, operation and maintenance of such equipment.
Only those persons are allowed to perform assembly, operation and maintenance.
2. Read and understand this Operation Manual carefully before assembling, operating or providing maintenance to the product.

■ Safety Instructions

Warning	
 Disassembly prohibited	Do not disassemble, modify (including the replacement of board) or repair other than instructed in this manual. Otherwise, an injury or failure can result.
 Do not	Do not operate the product outside of the specifications. Do not use for flammable or harmful fluids. Fire, malfunction, or damage to the product can result. Please check the specifications before use.
 Do not	Do not use in an atmosphere containing flammable or explosive gases. Fire or an explosion can result. The product is not designed to be explosion proof.
 Do not	Do not use the product in a place where static electricity is a problem. Otherwise failure or malfunction of the system can result.
 Do not	Do not cut off the power and compressed air supplied to this product while it is operating. Otherwise it can cause injury due to dropping of workpieces or damage to the system.
 Instruction	If using the product in an interlocking circuit - Provide a double interlocking system, for example a mechanical system. - Check the product for proper operation. Otherwise malfunction can result, causing an accident.
 Instruction	The following instructions must be followed during maintenance - Turn off the power supply - Stop the air supply, exhaust the residual pressure in piping and verify that the air is released before performing maintenance work. It may cause an injury.

Caution

 Do not touch	<p>Do not touch the terminals and connectors while the power is on. Otherwise electric shock, malfunction or damage to the switch can result.</p>
 Instruction	<p>Perform sufficient trial run. Otherwise, injury or damage to the system can result due to suction failure depending on the conditions of the suction of the workpiece or the pressure switch settings. Perform sufficient verification before using this product.</p>
 Instruction	<p>After maintenance is complete, perform appropriate functional inspections and leak test. Stop operation if the equipment does not function properly or there is leakage of fluid. If there is leakage from parts other than the piping, the product might be broken. Cut off the power supply and stop the fluid supply. Do not supply fluid if there is leakage. Safety cannot be assured in the case of an unexpected malfunction.</p>

■ Precautions for Handling

Follow the instructions given below for selecting and handling of the vacuum gripper.

*Product specifications

- It is recommended to use compressed air which purity class is 2:6:3 of ISO8573-1:2010.
- The applicable fluid is air.
Do not use a fluid containing chemicals, synthetic oils including organic solvent, salt and corrosive gases.
Otherwise, damage to the vacuum gripper and malfunction can result.
- Use the specified operating pressure.
- Reserve a space for maintenance.
Design the system allowing the required space for maintenance.
- Use the specified voltage. Otherwise failure or malfunction can result.
- Do not exceed the specified maximum allowable load. Otherwise it can cause damage or shorten the life of the product.
- Design the product to prevent reverse current when the circuit is opened or the product is forced to operate for operational check. Reverse current can cause malfunction or damage the vacuum gripper.

*Operating environment

- Do not use in an environment where corrosive gases, chemicals, sea water, water or steam are present.
- Do not use the product in a place where the product could be splashed by oil or chemicals.
If the product is to be used in an environment containing oils or chemicals such as coolant or cleaning solvent, even for a short time, the solenoid valve or pressure switch may be adversely affected (damage, malfunction, or hardening of the cable and the lead wires).
- Do not use in an area where surges are generated.
When there are machines or equipment that generate large surge near the pressure switch (magnetic type lifter, high frequency inductive furnace, motor, etc.), this can result in deterioration and damage of the internal elements. Take measures against the surge sources, and prevent the lines from coming into close contact.
- Do not use a load which generates surge voltage.
When a surge-generating load such as a relay or solenoid is directly driven, use the product with a surge absorbing element built-in.
- Mount the product in a location that is not affected by vibration or impact.
It will cause failure or malfunction.
- Do not use the product in an environment that is exposed to temperature cycle.
Heat cycles other than ordinary changes in temperature can adversely affect the inside of the product.
- Do not expose the product to direct sunlight.
If using in a location directly exposed to sunlight, protect the product from the sunlight.
- Keep within the specified operating fluid and ambient temperature range.
Operation under low temperature may lead to damage or operation failure due to frozen moisture in the fluid or air.
Protection against freezing is necessary. Mounting of an air dryer is recommended for elimination of drainage and water.
Avoid abrupt temperature changes even within the specified temperature range.
- Do not use in a location where the product is exposed to radiant heat from surrounding heat sources.
Insufficient air quality may cause operation failure.

1. Parts included in the package

1.1. In case of ZXP7*11

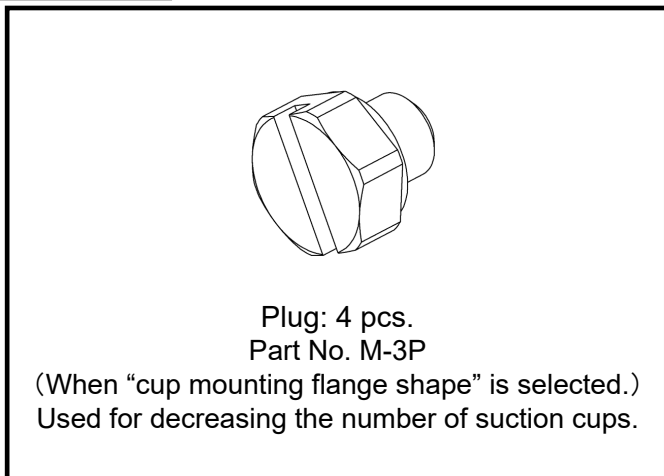
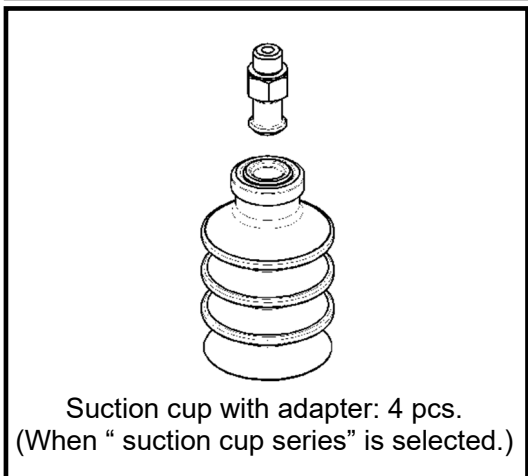
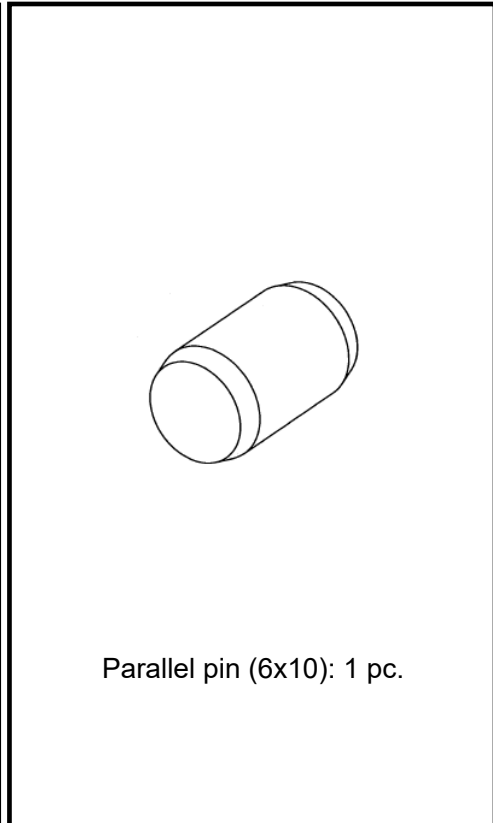
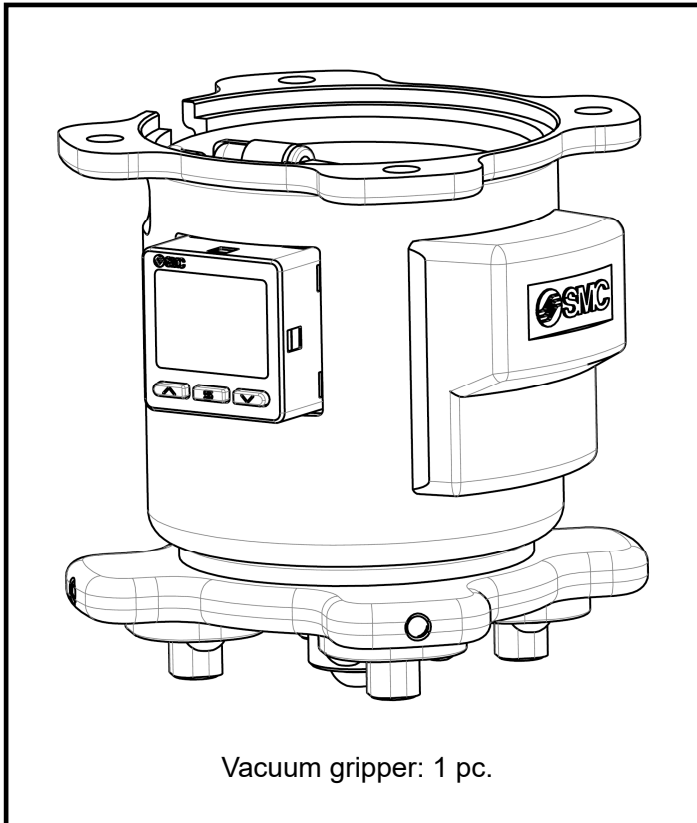
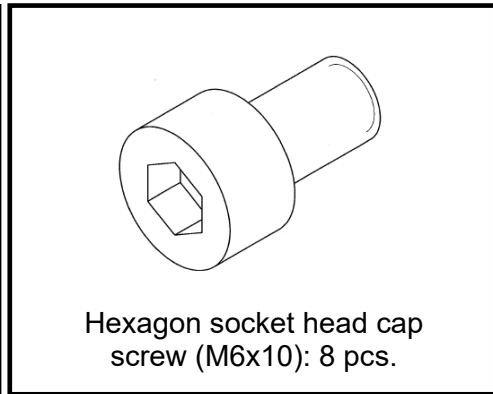
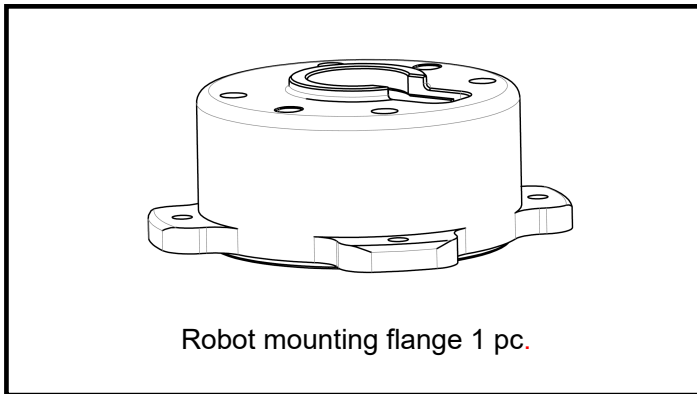

1.2. In case of ZXP7*12

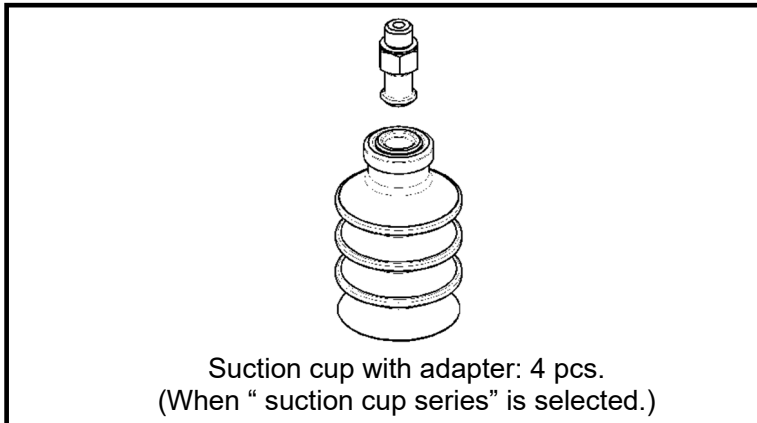
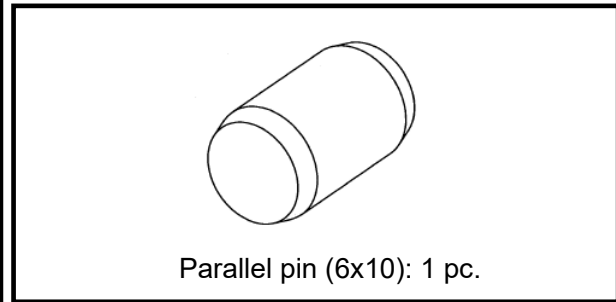
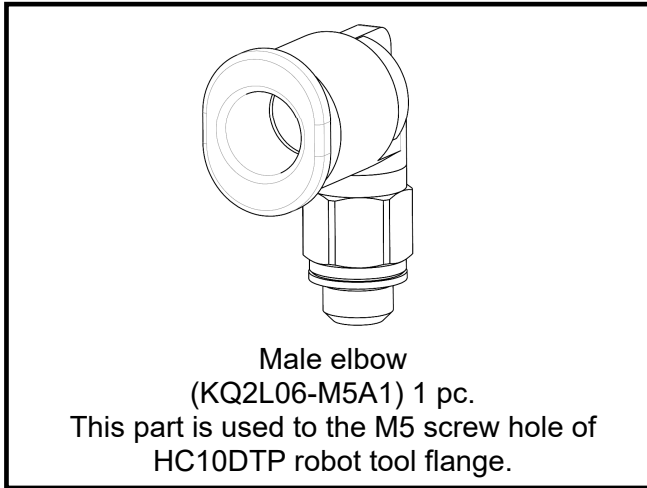
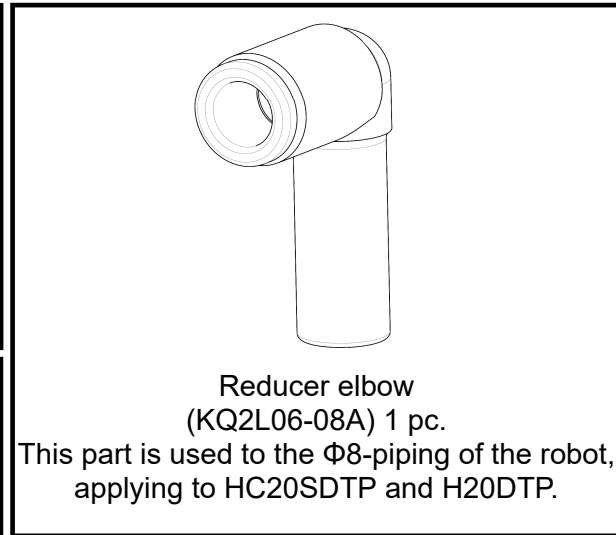
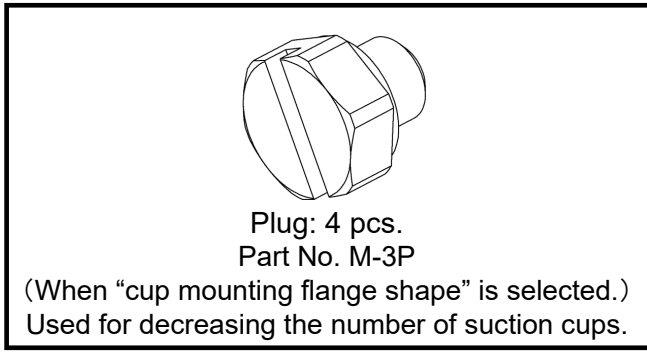
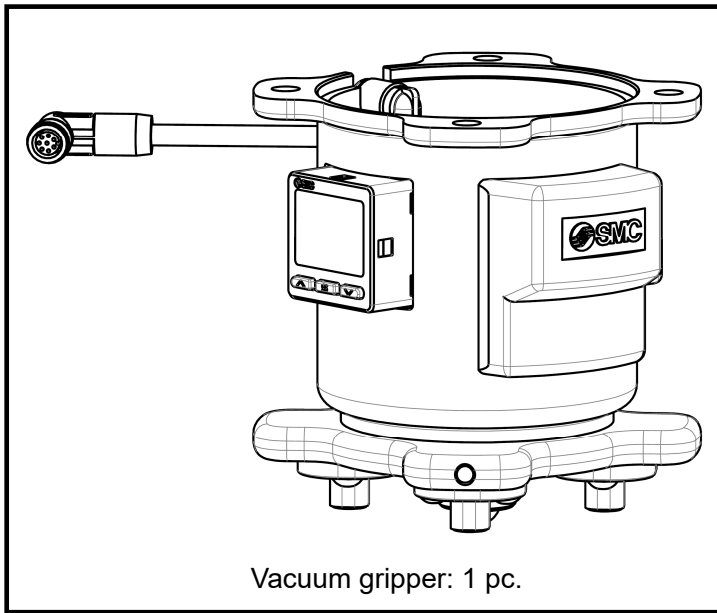
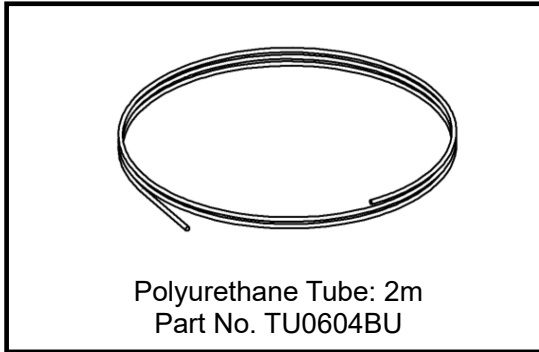
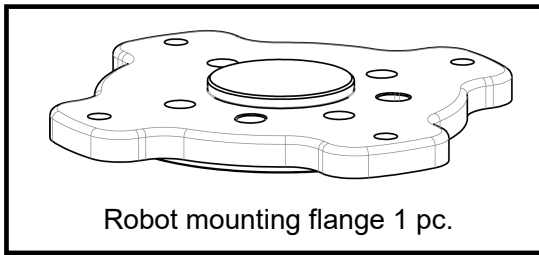

2. Names of Parts of the Product

2.1. In case of ZXP7*11

Details of internal parts

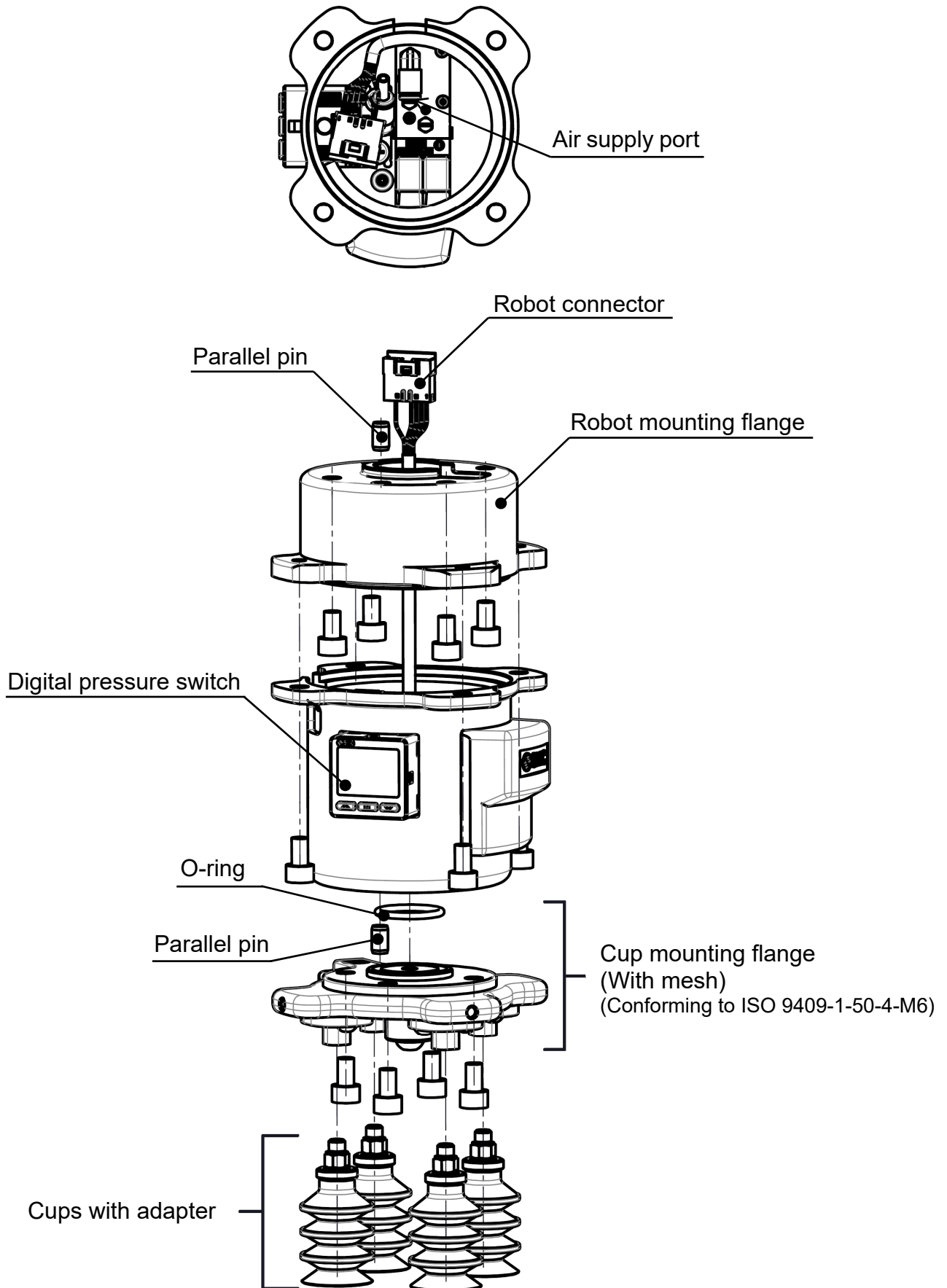

2.2. In case of ZXP7*12

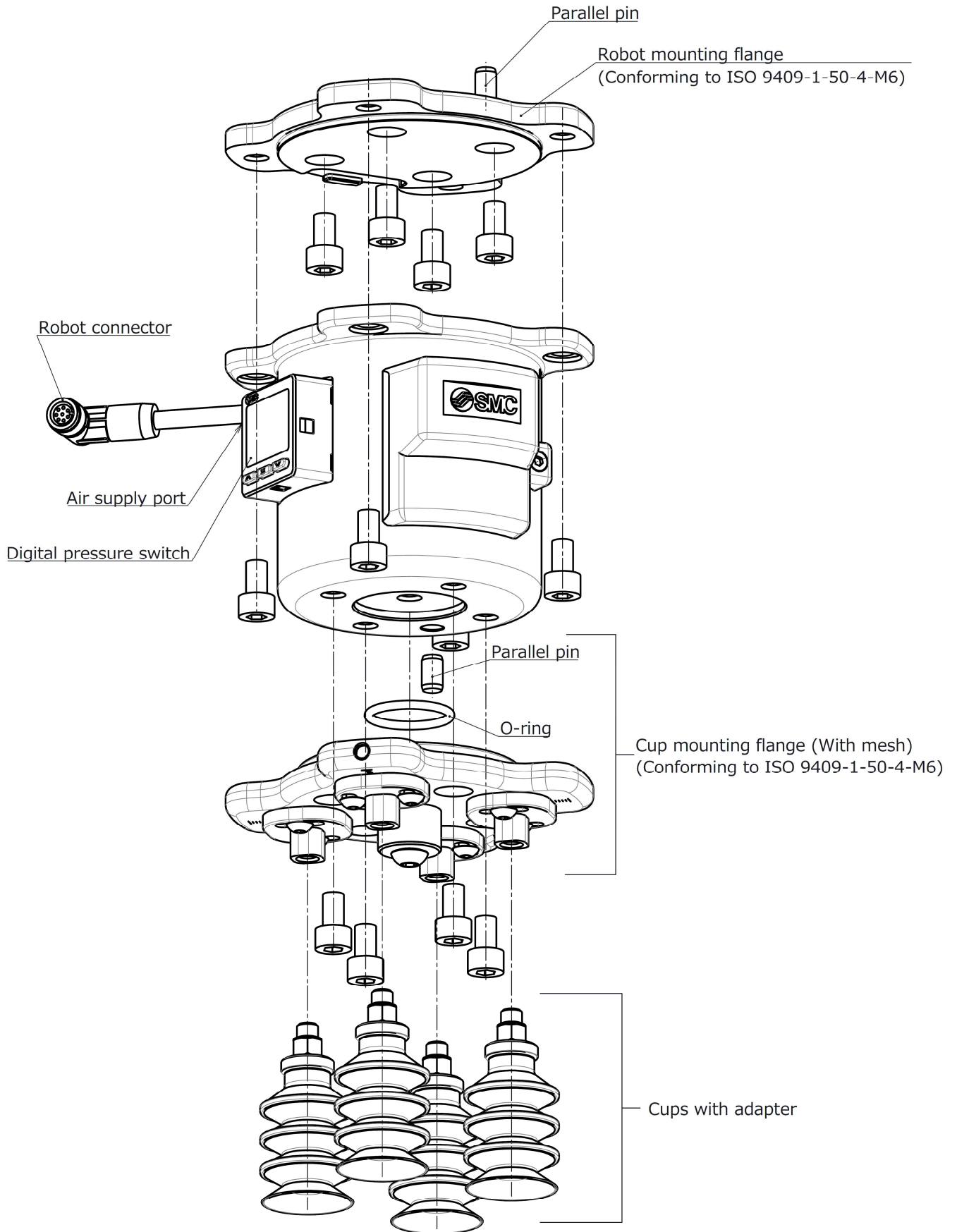

3. Specifications

3.1. Specifications

■ Product specifications

Common	Applicable part number		ZXP7*11	ZXP7*12
	Standards		-	Conforming to ISO 9409-1-50-4-M6
	Applicable fluid		Air	
	Operating temperature range [°C]		5 to 50	
	Connector type		MOLEX 51227-0800	M8 8-pin connector (Socket)
	Weight [g]	ZXP7N*-X1*	671	586
		ZXP7A*-X1*	895	810
		Example) ZXP7A*-ZPB25JS-X1	948 note1)	863 note1)
	Max. workload [kg] Note2)		7	
	Impact / Vibration resistance [m/s ²] Note3)		150 / 30	
	Air pressure supply (P) port		Built-in One-touch fittings (Φ4)	Built-in One-touch fittings (Φ6)
Power supply voltage [V]		24 VDC ±10%		
Vacuum ejector	Max. vacuum pressure [kPa] note4)		-84	
	Suction flow rate [L/min(ANR)] note4)		17	
	Air consumption [L/min(ANR)] note4)		57	
	Supply pressure range [MPa]		0.3 to 0.55	
	Standard supply pressure [MPa] note5)		0.5	
Valve	Model		V114	
Pressure switch	Model		ZSE20-*-*-M5-A1	
	Rated pressure range [kPa]		0 to -101	
	Display accuracy [%]		±2 F.S. ±1 digit (Ambient temperature of 25°C ±3°C)	
	Repeatability [%]		±0.2 F.S. ±1 digit	
	Temperature characteristics [%]		±2 F.S. (25°C conversion)	
Applicable suction cups		Refer to "3.4. How to order"		

Note 1) The weight changes by the selected suction cup. Refer to "3.4 How to order".

Note 2) May be restricted depending on the cup diameter, mounting orientation, or workpiece. Please use within the max. workload. Suction and transfer exceeding the max. work load may result in reduced vacuum pressure due to air leakage.

Note 3) Impact resistance: The characteristics are satisfied after tested one time in each of the X, Y and Z directions without energization. (Initial value)

Vibration resistance: The characteristics are satisfied after tested a one sweep in each of the X, Y and Z directions at 10 to 500 Hz without energization. (Initial value)

Note 4) Values are at the standard supply pressure and based on SMC's measurement standards.

They depend on atmospheric pressure (weather, altitude, etc.) and the measurement method.

Note 5) This value indicates the pressure right before the air pressure supply pressure (P) port when vacuum is generated.

The pressure right before the P port of the vacuum gripper when vacuum is generated may fall below 0.5 MPa due to the air supply capacity, piping size, and the amount of air being consumed by other devices being operated simultaneously.

3.2. Flow rate / Exhaust characteristics

■ Flow rate / Exhaust characteristics.

The flow rate characteristics correspond to the standard supply pressure (0.5MPa).

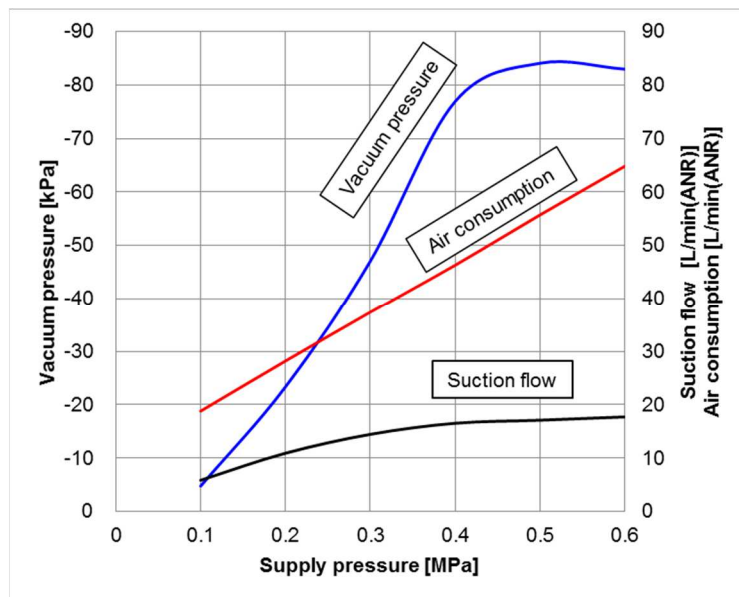

Exhaust characteristics

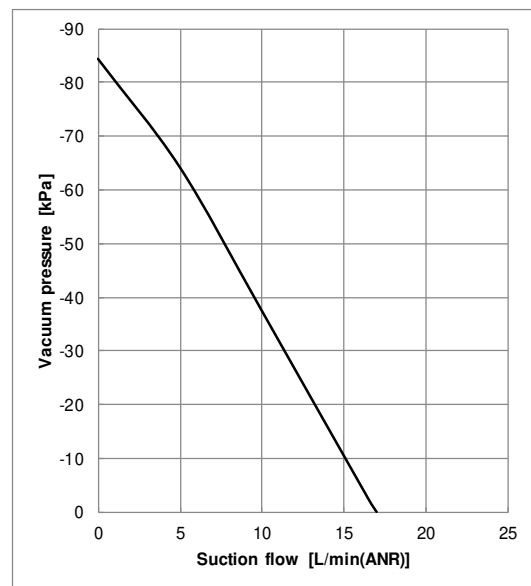

Flow rate characteristics

* The actual suction flow at the point of suction varies depending on the piping conditions to the vacuum port.

■ How to read the flow rate characteristics Graph

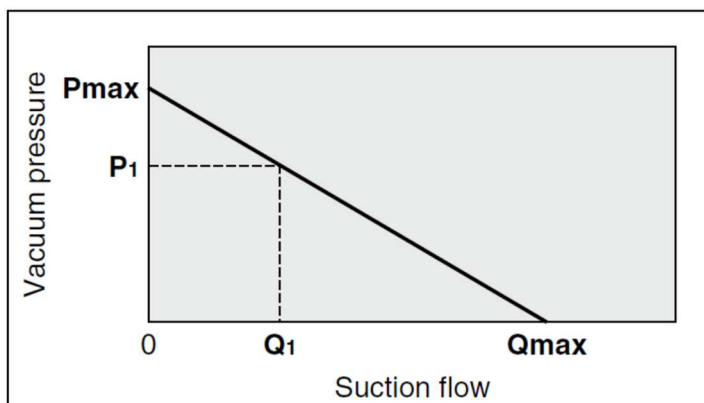

Flow rate characteristics are expressed in ejector vacuum pressure and suction flow. If suction flow changes, the vacuum pressure will also be changed. Normally this relationship is expressed in ejector standard operating pressure use. In the graph, Pmax is maximum vacuum pressure and Qmax is maximum suction flow. The values are specified according to catalog use. Changes in vacuum pressure are expressed in the below order.

1. When the ejector suction port is covered and made airtight, the suction flow becomes zero and vacuum pressure is at the maximum value (Pmax).
2. When the suction port is opened gradually, air can flow through, (air leakage), suction flow increases, but vacuum pressure decreases. (condition P1 and Q1)
3. When the suction port is opened further and fully opened, suction flow moves to the maximum value (Qmax), but vacuum pressure is near zero (atmospheric pressure).

As described above, the vacuum pressure changes when the suction flow changes. In other words, when there is no leakage from the vacuum port, the vacuum pressure can reach its maximum, but as the amount of leakage increases, the vacuum pressure decreases. When the amount of leakage and the maximum suction flow become equal, the vacuum pressure becomes almost zero.

In the case when a ventilative or leaky workpiece should be gripped, take note that vacuum pressure will not rise.

3.3. How to calculate theoretical lifting force

*This manual shows how to calculate theoretical lifting force only. Refer to the catalog of suction cups for further detail of suction cup selection method.

■ How to calculate theoretical lifting force

The theoretical lifting force of a cup can be found by calculation or from the theoretical lifting force table.

Calculation

$$W = P \times S \times 0.1 \times \frac{1}{t}$$

W: Lifting force [N]

P: Vacuum pressure [kPa]

S: Cup area [cm²]

t: Safety factor Horizontal lifting: 4 or more

Vertical lifting: 8 or more

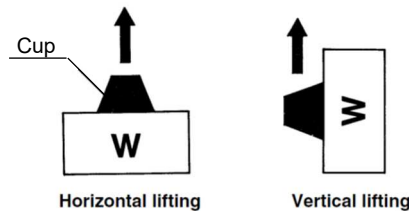

(This type of application should generally be avoided.)

Theoretical lifting force table

The theoretical lifting force (not including the safety factor) can be determined by the cup diameter and vacuum pressure.

The required lifting force can then be determined by dividing the theoretical lifting force by the safety factor t.

$$\text{Lifting force} = \text{Theoretical lifting force} / t$$

Theoretical lifting force (Theoretical lifting force = P x S x 0.1)

Cup diameter (Φ8 to Φ32)

[N]

Cup diameter [mm]	Φ8	Φ10	Φ13	Φ16	Φ20	Φ25	Φ32	
S: Cup area [cm ²]	0.50	0.79	1.33	2.01	3.14	4.91	8.04	
Vacuum pressure [kPa]	-85	4.2	6.6	11	17	26	41	68
	-80	4.0	6.2	10	16	25	39	64
	-75	3.7	5.8	10	15	23	36	60
	-70	3.5	5.5	9.3	14	22	34	56
	-65	3.2	5.1	8.6	13	20	31	52
	-60	3.0	4.7	8.0	12	18	29	48
	-55	2.7	4.3	7.3	11	17	27	44
	-50	2.5	3.9	6.7	10	15	24	40
	-45	2.2	3.5	6.0	9.0	14	22	36
-40	2.0	3.1	5.3	8.0	12	19	32	

3.4. How to order

■ Vacuum Gripper

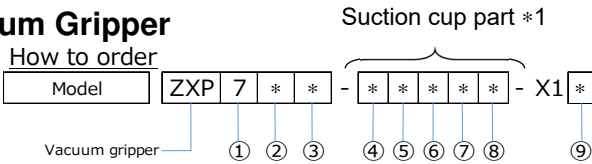

*1 Refer to the table below for the applicable cups. For models with cups, 4 cups with adapters are included in the package.

1) Body size

Symbol	Size
7	75mm

2) Cup mounting flange shape

Symbol	Flange shape
A	With flange (42 mm x 42 mm)
N	Without flange

3) Compatible robot manufacturer

Symbol	Robot manufacturer
11	YASKAWA Electric Corporation: MOTOMAN-HC10DT
12	YASKAWA Electric Corporation: MOTOMAN-HC10DTP, MOTOMAN-HC20DTP, MOTOMAN-HC20SDTP

4) Cup series

Symbol	Cup series
ZP	Basic
ZP3P	Bellows type for film packaging workpieces
Nil	Without cup

5) Cup diameter

Symbol	Cup diameter
08	Φ8
10	Φ10
13	Φ13
16	Φ16
20	Φ20
25	Φ25
B25	Φ25
B30	Φ30
32	Φ32
Nil	Without cup

6) Cup form

Symbol	Cup form
U	Flat
C	Flat with rib
B	Bellows
UT	Thin flat
J	Multistage bellows
JT2	2.5-stage bellows
JT5	5.5-stage bellows
Nil	Without cup

7) Cup material

Symbol	Material
N	NBR
S	Silicone rubber (White) *2
U	Urethane rubber
F	FKM
SF	Silicone rubber (Blue) *2
Nil	Without cup

8) Attachment *3

Symbol	Attachment
Nil	With (guide) attachment
M	With mesh attachment

*3 Only applicable to the cup form "JT□." Note that "M" applies only to cup form: JT2.

9) Pressure switch output specifications/Unit

Symbol	Output/Unit
Nil	NPN/With unit switching function *4
A	NPN/NI unit only *5
B	NPN/With unit switching function (Initial value psi) *4
C	PNP/With unit switching function *4
D	PNP/SI unit only *5
E	PNP/With unit switching function (Initial value psi) *4

*4 Under the New Measurement Act, switches with the unit switching function are not permitted for use in Japan.

*5 Fixed unit: kPa, MPa

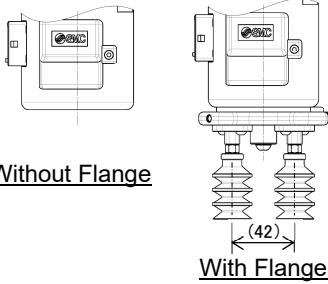

· See the table below for the suction cup part combination.

· Refer to the catalog of suction cup on the SMC website for the detail of suction cup.

*1

■ Suction Cup Part Numbers and Weight

ZXP7(A,N)(11,12) - (4) (5) (6) (7) (8) -X1

Applicable cups					Cup part numbers						
(4) Cup series	(5) Cup diameter	(6) Cup form	(7) Cup material	(8) Attachment	Cup with adapter				Adapter unit (Vacuum inlet: Male thread M6x1)	Cup unit	
					Weight by cup material (g/cup)						
					Part no.	N (NBR)	S/SF (Silicone)	U (Urethan)	F (FKM)		
ZP	08	U	*		ZPT08U*-A6	4	4	4	4	ZPT1-A6	ZP08U*
ZP	08	B	*		ZPT08B*-A6	4	4	4	4		ZP08B*
ZP	10	UT	*		ZPT10UT*-A6	4	4	4	4	ZPT2-7A-X2	ZP10UT*
ZP	13	UT	*		ZPT13UT*-A6	4	4	4	4		ZP13UT*
ZP	16	UT	*		ZPT16UT*-A6	4	4	4	4	ZPT3-7A-X2	ZP16UT*
ZP	10	U	*		ZPG10U*-7A-X2	7	7	7	7		ZP10U*
ZP	13	U	*		ZPG13U*-7A-X2	7	7	7	8	ZPT2-7A-X2	ZP13U*
ZP	16	U	*		ZPG16U*-7A-X2	7	7	7	8		ZP16U*
ZP	20	U	*		ZPG20U*-7A-X2	9	10	10	10	ZPT3-7A-X2	ZP20U*
ZP	25	U	*		ZPG25U*-7A-X2	10	10	10	11		ZP25U*
ZP	32	U	*		ZPG32U*-7A-X2	10	11	11	12	ZPT2-7A-X2	ZP32U*
ZP	10	C	*		ZPG10C*-7A-X2	7	7	7	7		ZP10C*
ZP	13	C	*		ZPG13C*-7A-X2	7	7	7	7	ZPT3-7A-X2	ZP13C*
ZP	16	C	*		ZPG16C*-7A-X2	7	7	7	8		ZP16C*
ZP	20	C	*		ZPG20C*-7A-X2	9	10	10	11	ZPT2-7A-X2	ZP20C*
ZP	25	C	*		ZPG25C*-7A-X2	10	10	10	11		ZP25C*
ZP	32	C	*		ZPG32C*-7A-X2	10	11	11	12	ZPT3-7A-X2	ZP32C*
ZP	10	B	*		ZPG10B*-7A-X2	7	7	7	8		ZP10B*
ZP	13	B	*		ZPG13B*-7A-X2	7	8	8	8	ZPT2-7A-X2	ZP13B*
ZP	16	B	*		ZPG16B*-7A-X2	8	8	8	9		ZP16B*
ZP	20	B	*		ZPG20B*-7A-X2	11	11	11	13	ZPT3-7A-X2	ZP20B*
ZP	25	B	*		ZPG25B*-7A-X2	11	12	12	14		ZP25B*
ZP	32	B	*		ZPG32B*-7A-X2	14	15	15	18	ZPT1-A6	ZP32B*
ZP	20	UT	*		ZPG20UT*-7A-X2	4	4	4	4		ZP2-20UT*
ZP	16	J	*		ZPG16J*-7A-X2	8	8	8	9	ZPT2-7A-X2	ZP2-16J*
ZP	B25	J	*		ZPGB25J*-7A-X2	14	15	15	18		ZP2-B25J*
ZP	B30	J	*		ZPGB30J*-7A-X2	18	19	19	25	ZPT3-7A-X2	ZP2-B30J*
ZP3P	20	JT2	SF		ZP3PG20JT2SF-7A-X2	-	21	-	-		ZP3PA-T1JT-7A-X2
ZP3P	20	JT2	SF	M	ZP3PG20JT2SF-M-7A-X2	-	21	-	-	ZP3P-20JT2SF-WM	
ZP3P	32	JT2	SF		ZP3PG32JT2SF-7A-X2	-	48	-	-	ZP3PA-T2JT-7A-X2	ZP3P-32JT2SF-W
ZP3P	32	JT2	SF	M	ZP3PG32JT2SF-M-7A-X2	-	48	-	-		ZP3P-32JT2SF-WM
ZP3P	20	JT5	SF		ZP3PG20JT5SF-7A-X2	-	23	-	-	ZP3PA-T1JT-7A-X2	ZP3P-20JT5SF-WG
ZP3P	25	JT5	SF		ZP3PG25JT5SF-7A-X2	-	25	-	-		ZP3P-25JT5SF-WG
ZP3P	32	JT5	SF		ZP3PG32JT5SF-7A-X2	-	54	-	-	ZP3PA-T2JT-7A-X2	ZP3P-32JT5SF-WG

Input the material symbol ("N," "S," "U," or "F") into the * in the part number.

4. Mounting

4.1. Mounting

■ Mounting procedure

- 1) Confirm the gasket seal on the adapter, then mount 4 cups with adapter to the vacuum gripper.
(Tightening torque: $1\text{N} \cdot \text{m}$ or tighten for 45 degrees using a spanner after tightening by hand)
- 2) Mount parallel pin to the robot tool flange pin hole.
- 3) Align the parallel pin of the robot tool flange with the robot mounting flange, and assemble them with bolts included in the accessories. (Tightening torque: $5.2\pm 0.5\text{Nm}$)
Connect the wiring after mount the robot mounting flange, when the part number is ZXP7*11.
(Refer to "4.2. Wiring".)
- 4) Tighten the vacuum gripper to the robot mounting flange.
(Tightening torque: $5.2\pm 0.5\text{Nm}$)

Removal should be performed by following the mounting procedure in reverse.

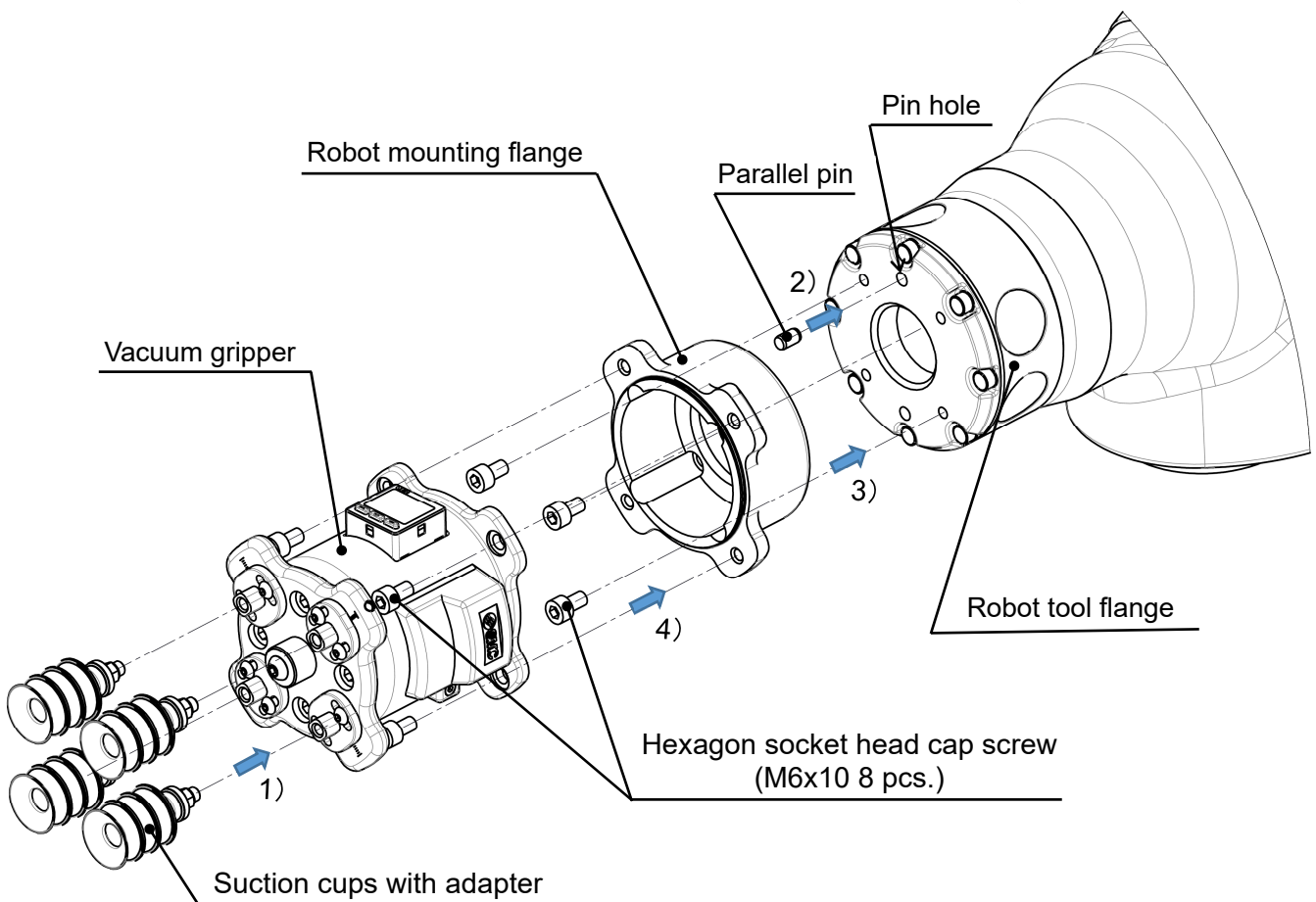
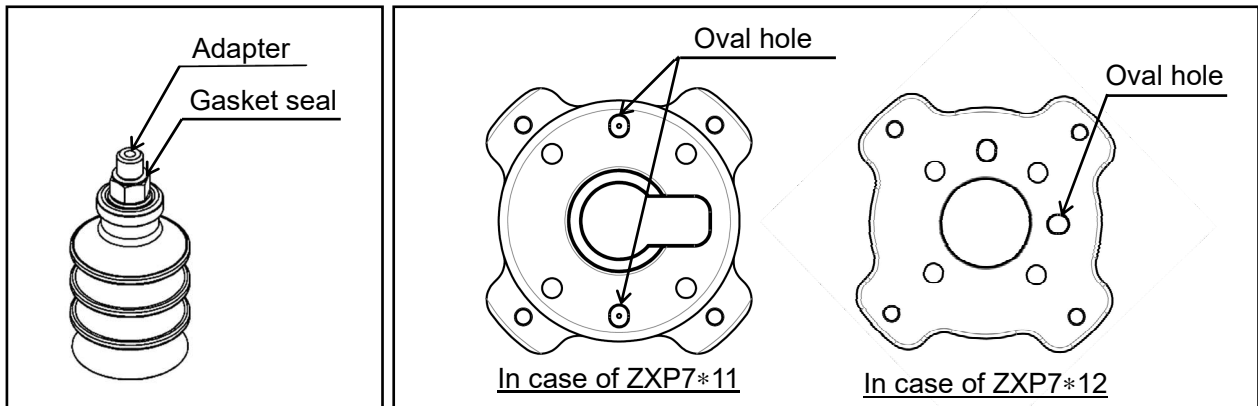

In case of ZXP7*11

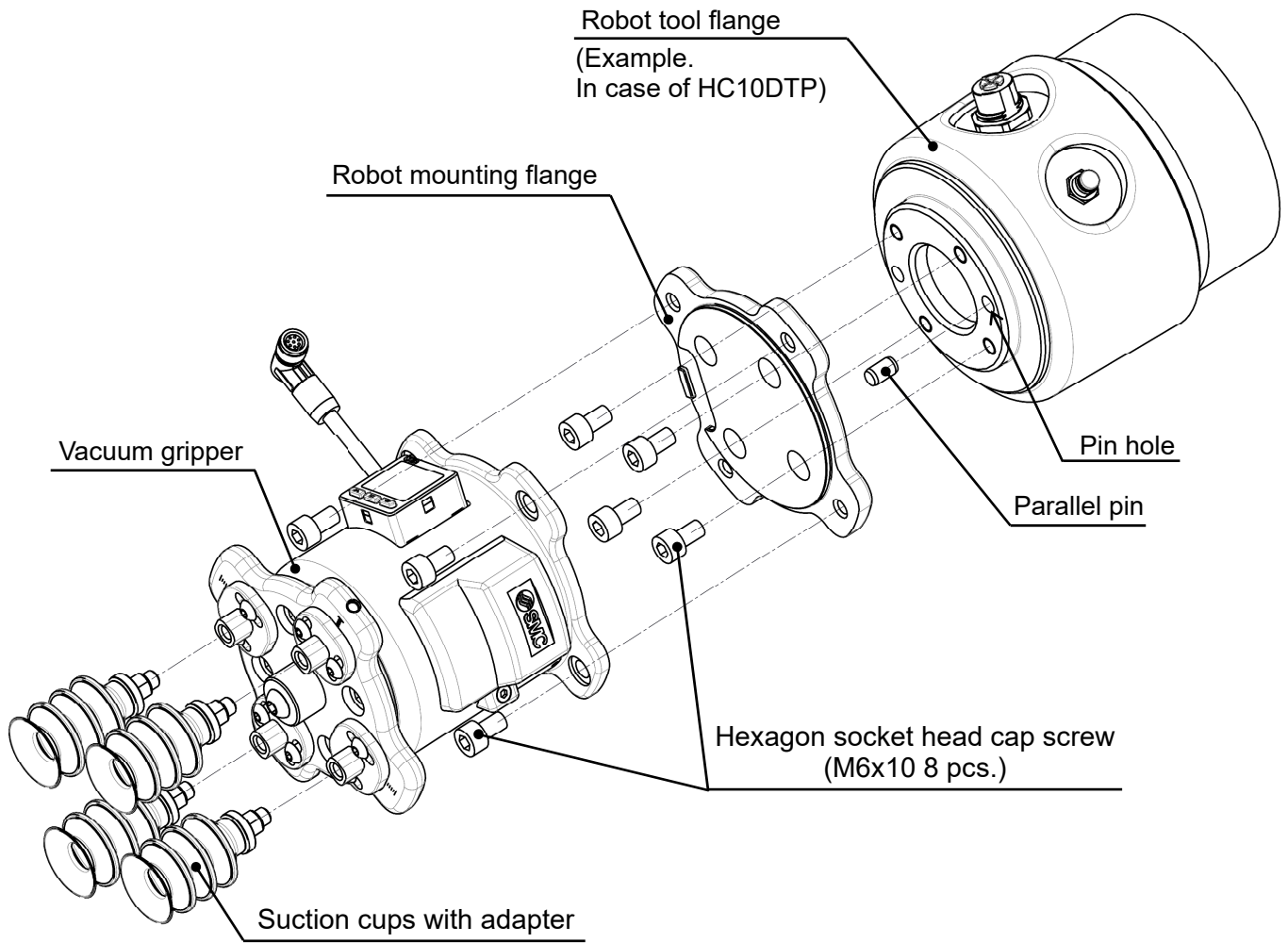

In case of ZXP7*12

4.2. Wiring

■Mount the connector cable

4.2.1. In case of ZXP7*11

After mounting Robot mounting flange, (After “4.1.3”), certainly connect both robot side connector being out from the hole of the robot tool flange and the vacuum gripper side connector until you hear a click. After connecting these, pull the connectors on both sides lightly and check that they do not through out.

⚠ Caution

Do not lift up the vacuum gripper by holding this cable. Otherwise it can cause open circuit.

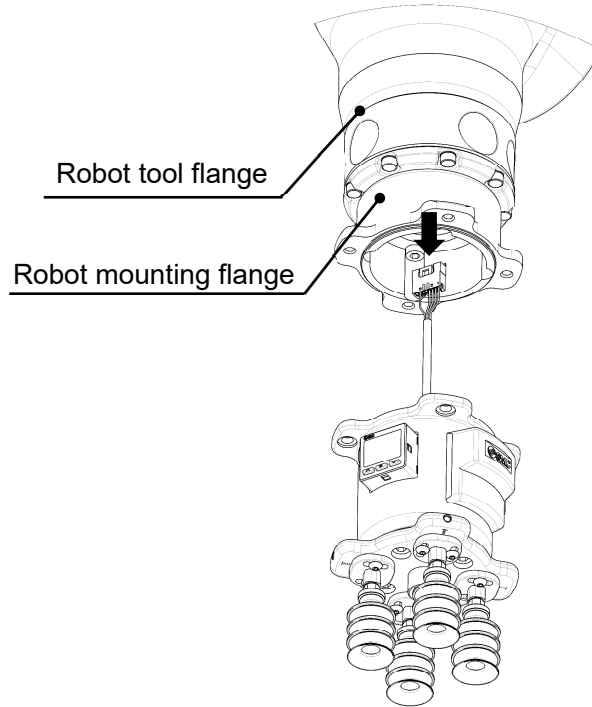

■Connector pin

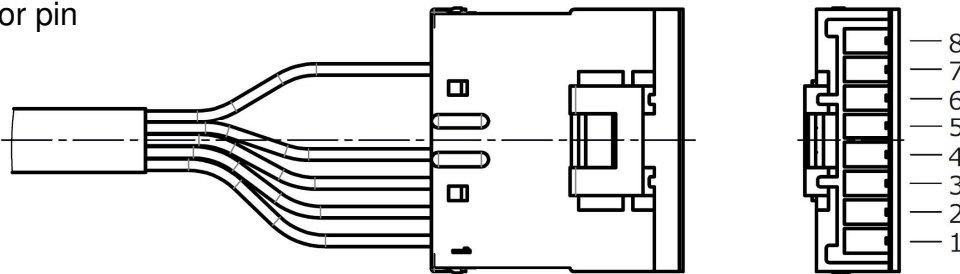

Pin number
Connector pin assignment

Connector pin assign

Pin no.	Wire color	Function
1	Red	Power supply voltage (24V)
2	Yellow	Power supply voltage (GND)
3	Black	Pilot valve for supply *
4	White	Release valve *
5	-	N.C.(Non connection)
6	-	N.C.(Non connection)
7	Green	Pressure switch output
8	-	N.C.(Non connection)

* Set the polarity of the robot output to the selected switch polarity (NPN/PNP).

4.2.2. In case of ZXP7*12

⚠ Caution

Install the vacuum gripper in the direction of the lower figure where the slack of the M8 connector cable is small.
If the cable is loose, it may be caught by peripheral equipment, workpiece, human body, etc. while the robot is running, causing unexpected accidents.

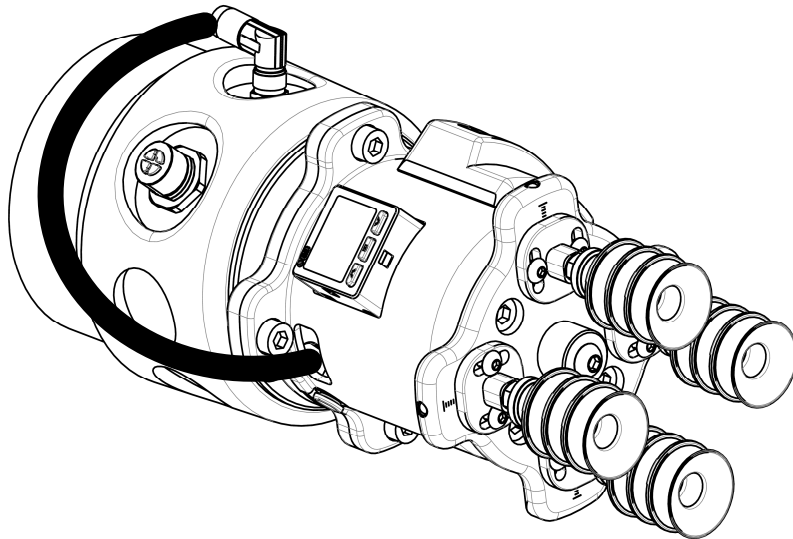

■ M8 Connector pin

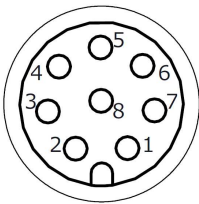

M8 Connector pin layout

Connector pin assign

Pin no.	Wire color	Function
1	-	N.C.(Non connection)
2	-	N.C.(Non connection)
3	Green	Pressure switch output
4	-	N.C.(Non connection)
5	Gray	Power supply voltage (24V)
6	Pink	Release valve *
7	Blue	Pilot valve for supply *
8	Red	Power supply voltage (GND)

* Set the polarity of the robot output to the selected switch polarity (NPN/PNP).

4.2.3. Wiring example to robot controller (common to NPN/PNP)

The table below shows wiring examples of I/O cables and general-purpose I/O terminal blocks. The connection of I/O cables to the general-purpose I/O terminal block should be done by the customer. Also, before wiring, be sure to confirm whether the robot controller specifications are NPN or PNP.

In case of ZXP7*11

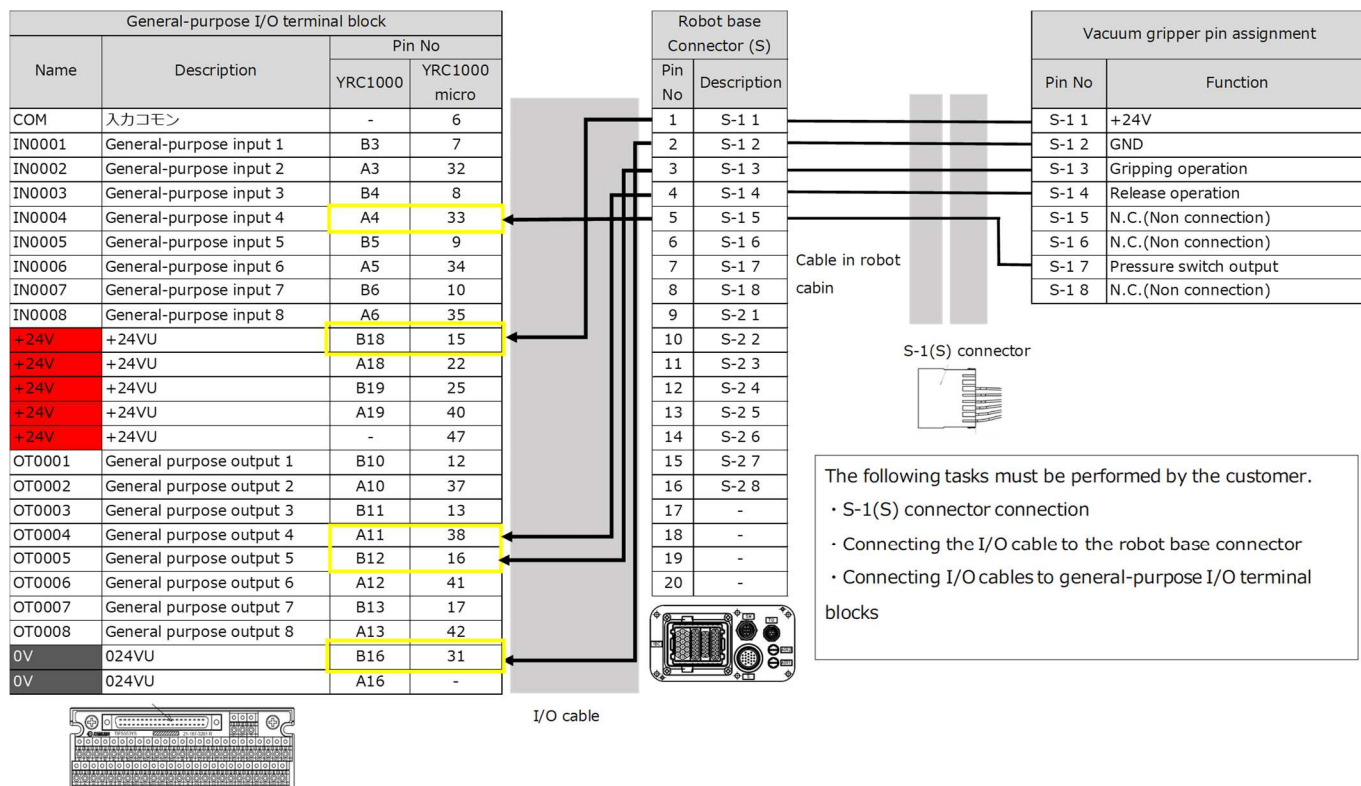

In case of ZXP7*12

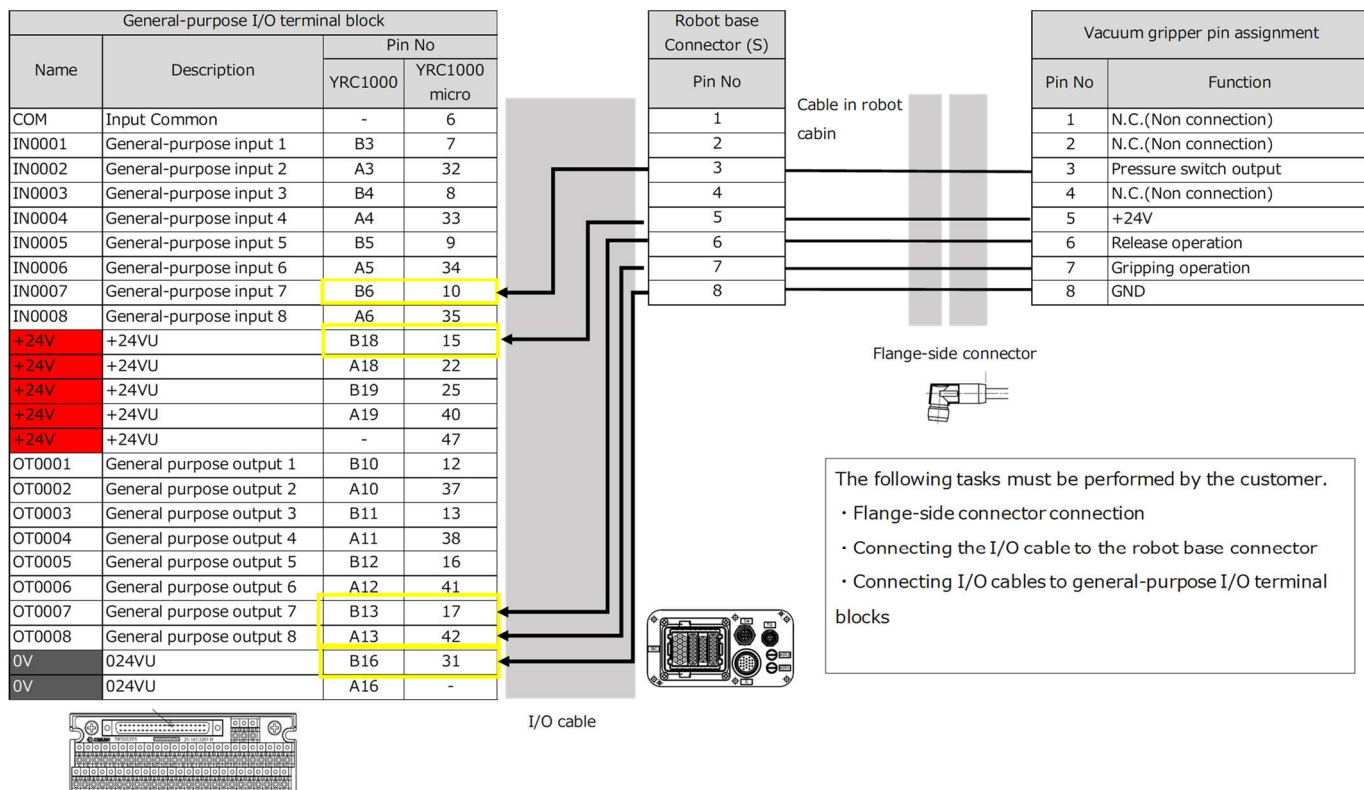

4.3. Piping

■ Tubing

Connect a tube (applicable tube O.D. $\varnothing 4$) to the air pressure supply (P) port.
To remove the tube, push the release button and pull out the tube.

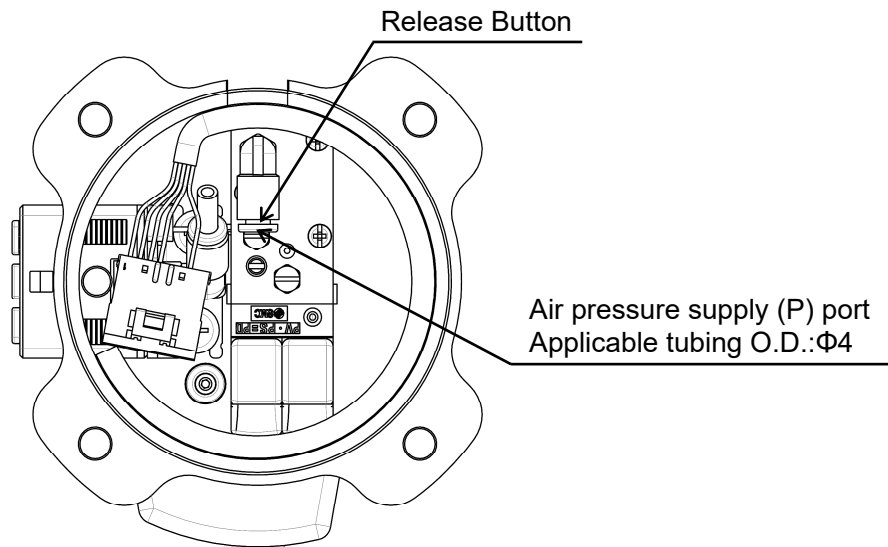

In case of ZXP7*11

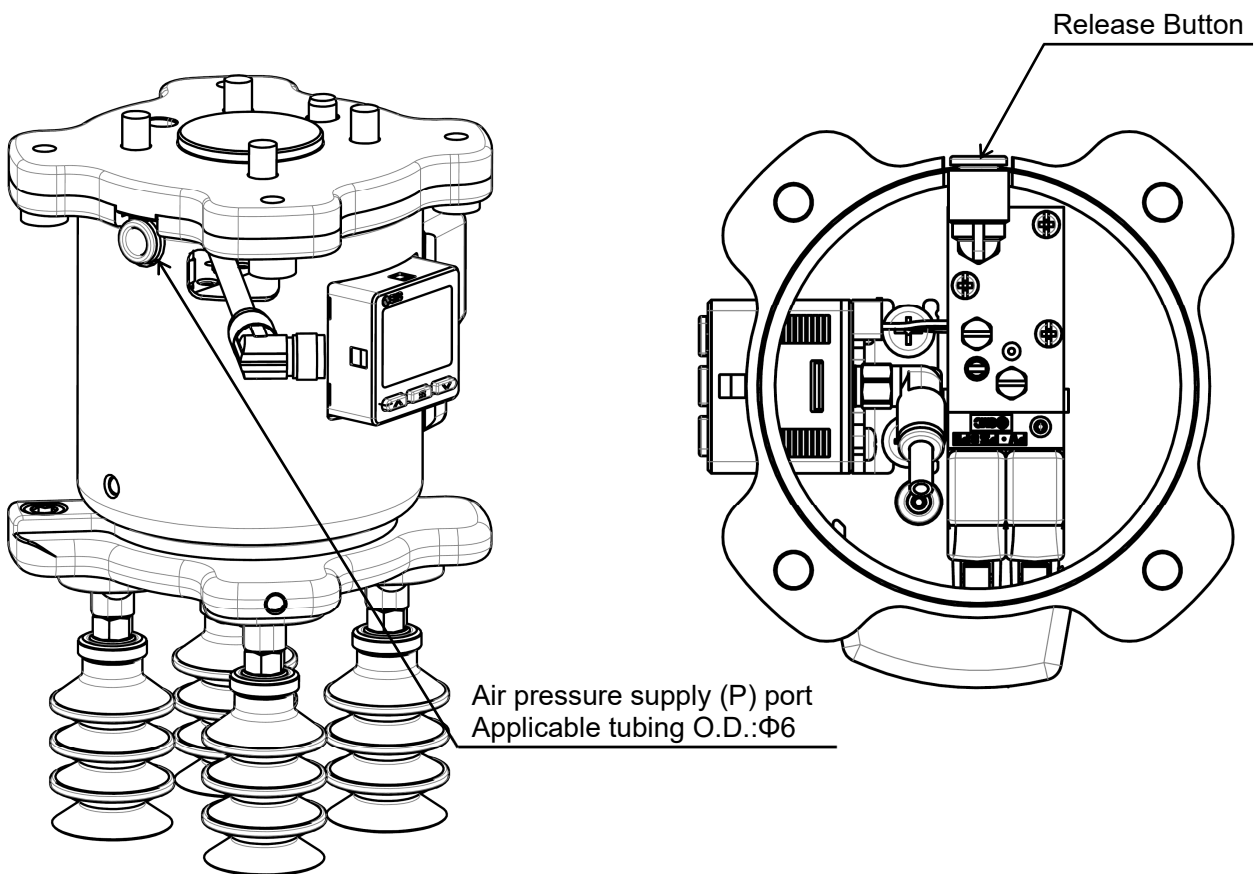

In case of ZXP7*12

4.4. YASKAWA plug & play kit

YASKAWA plug & play kit allows the vacuum gripper to be easily connected to and operated by the robot.

4.4.1. Installing YASKAWA plug & play kit

YASKAWA plug & play kit are installed in YASKAWA Installation Packages. YASKAWA Installation Packages (.yip) files.

*Please set the security access level to the management level.

1. Download the YASKAWA Installation Packages "SmcVacuumGripperExt.yip" from the SMC website.
2. Insert the USB stick with the downloaded file copied into the USB port of the smart pendant, select [MENU] in the upper left corner of the screen, and tap [System Settings] => [Packages].

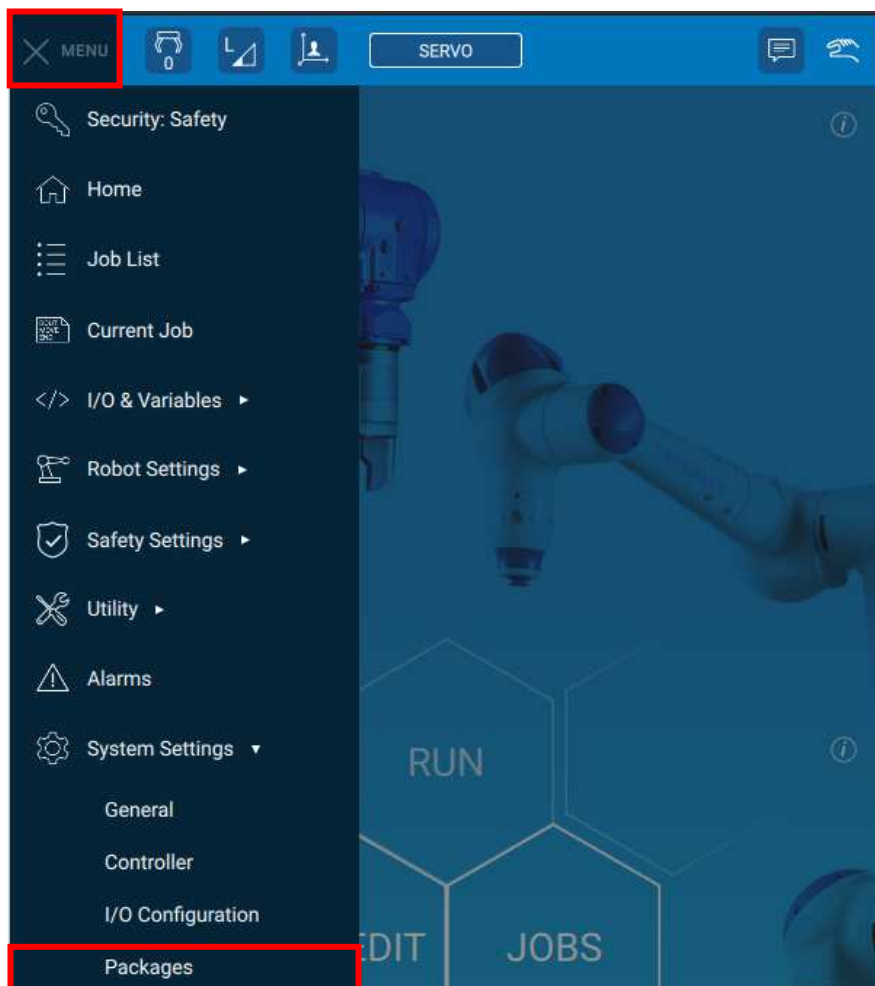

3. Open the [Packages] tab and tap [+ Install] at the top of the screen. A pop-up dialog will appear indicating the packages available for installation. Select "SMC Vacuum Gripper" from the list of packages to install.
After successful installation, packages, extensions, and tool presets are added to the appropriate lists.

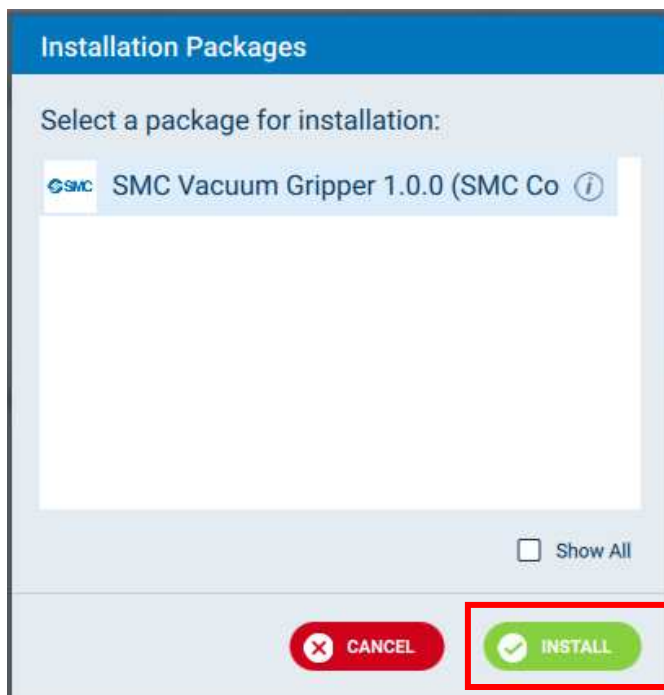
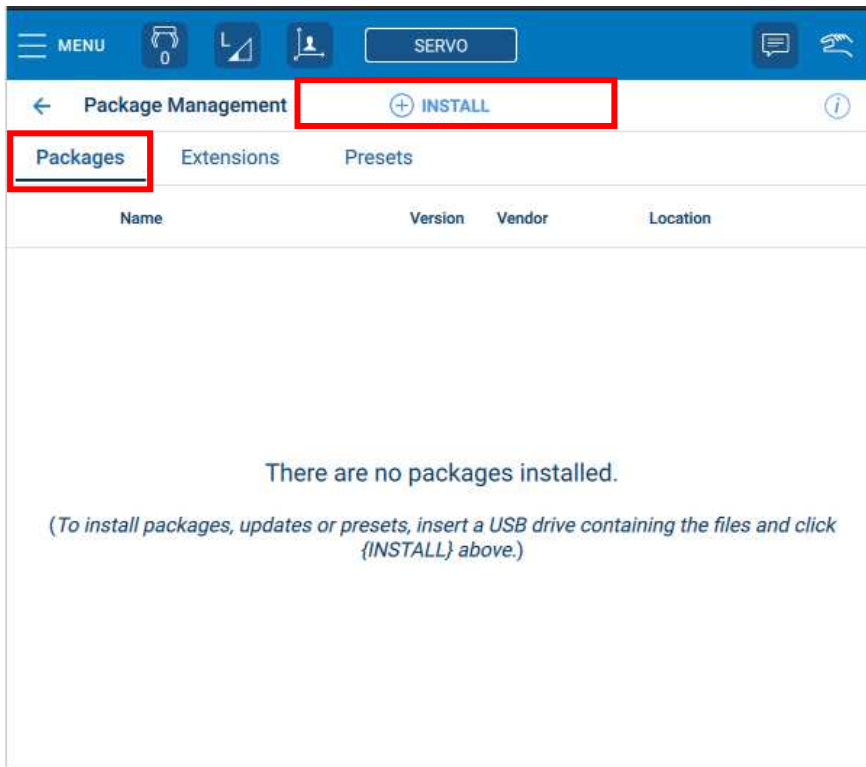

4. On the package management screen, confirm that the installation has completed successfully.

(1) Tap the [Packages] tab and verify that the SMC vacuum gripper has been added to the list.

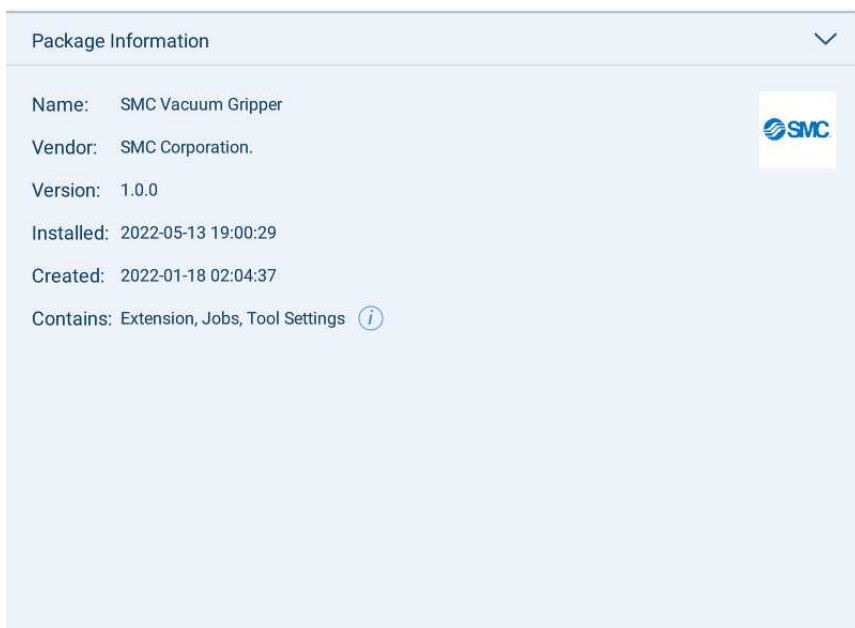
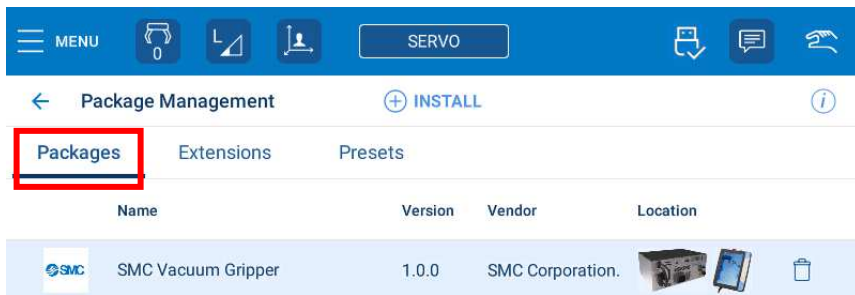

(2) Tap the [Extensions] tab and verify that the SMC vacuum gripper has been added to the list.

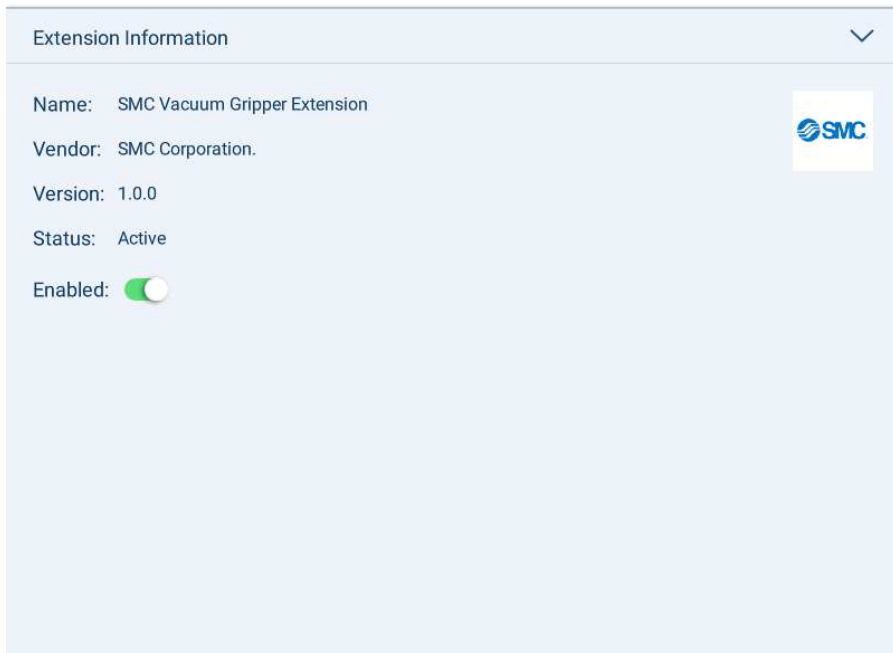
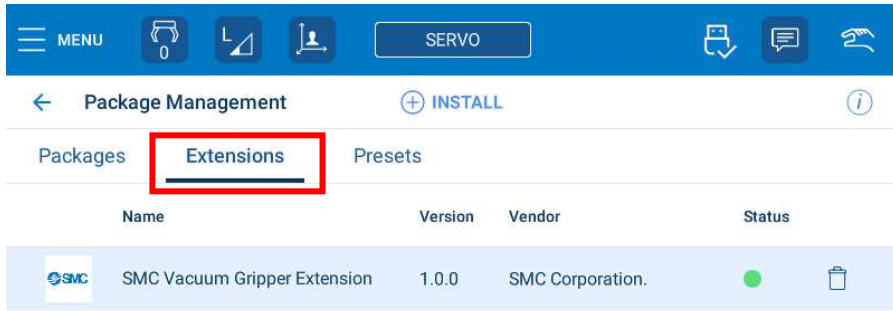

(3) Tap the [Presets] tab and verify that the SMC vacuum gripper has been added to the list.

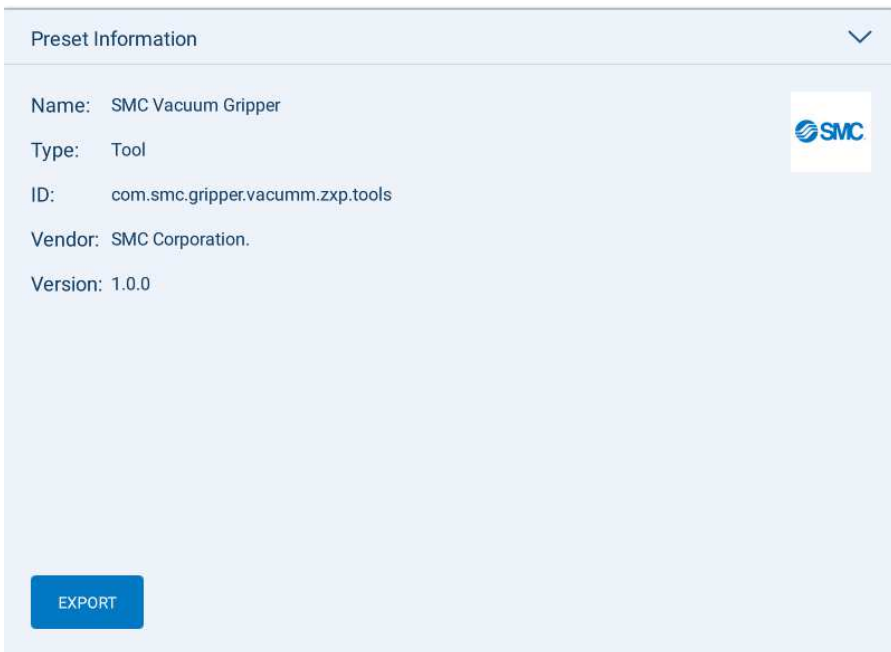
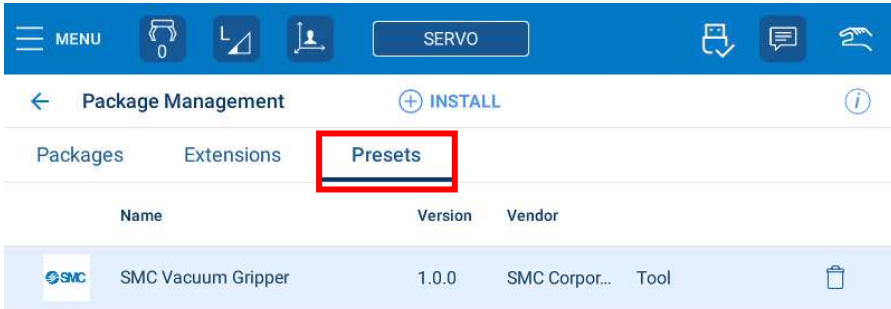

4.4.2. YASKAWA plug & play kit - Tool Presets

Selecting the SMC Vacuum Gripper from the list of installed tool presets will immediately copy the SMC Vacuum Gripper's tool property settings to the appropriate tool settings text field for the currently selected tool. Properties are not immediately applied and can be further edited manually before saving.

Tool #5: CTool5

Select preset to apply: SMC Vacuum Gripper

General Interference

Name: CTool5 Block I/O: Not Assigned

Tool Center Point (TCP) Orientation: ESTIMATE Show without tool

X _F	0.000 mm	R _X	0.0000 deg
Y _F	0.000 mm	R _Y	0.0000 deg
Z _F	0.000 mm	R _Z	0.0000 deg

Weight: ESTIMATE

W: 0.000 kg

Center of Gravity: Moment of Inertia

X _G	0.000 mm	I _x	0.000 kg·m ²
Y _G	0.000 mm	I _y	0.000 kg·m ²
Z _G	0.000 mm	I _z	0.000 kg·m ²

Tool #5: SMC Vacuum Gripp

PRESETS

General Interference

Name: SMC Vacuum Gripp Block I/O: Not Assigned

Tool Center Point (TCP) Orientation: ESTIMATE Show without tool

X _F	0.000 mm	R _X	0.0000 deg
Y _F	0.000 mm	R _Y	0.0000 deg
Z _F	153.400 mm	R _Z	0.0000 deg

Weight: ESTIMATE

W: 0.887 kg

Center of Gravity: Moment of Inertia

X _G	-0.280 mm	I _x	0.002 kg·m ²
Y _G	0.920 mm	I _y	0.002 kg·m ²
Z _G	56.320 mm	I _z	0.001 kg·m ²

4.4.3. YASKAWA plug & play kit - Utility Window

1. Select [MENU] in the upper left corner of the screen, tap [Utility] => [SMC Vacuum Gripper], or tap [Jog Operation] on the navigation bar in the Job Contents View screen, then tap the "Vacuum Gripper" icon in the lower right corner of the screen to open the Utility window.

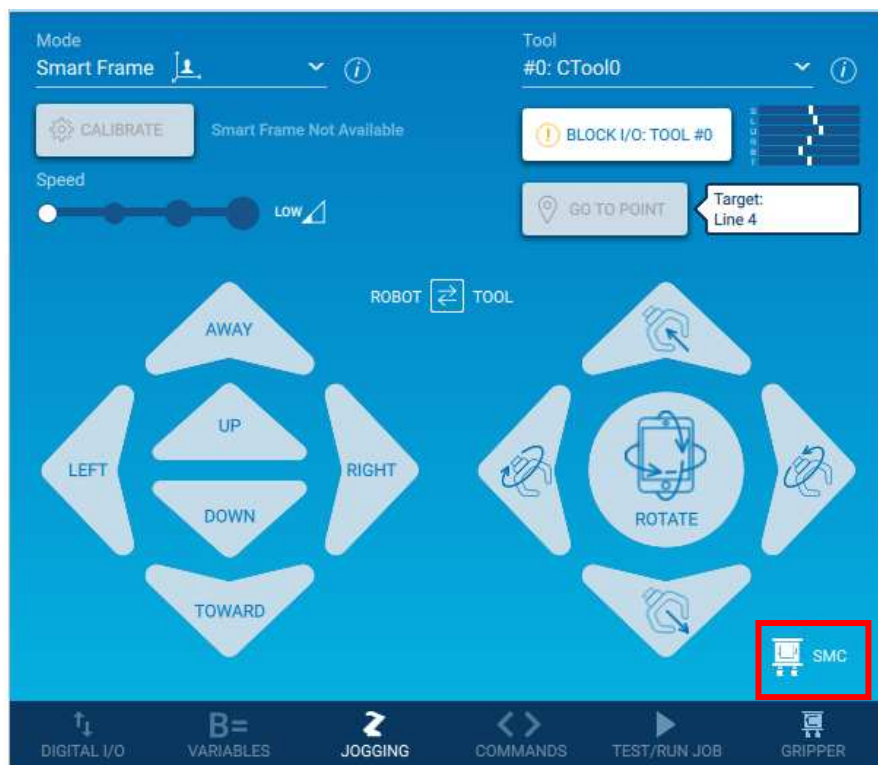
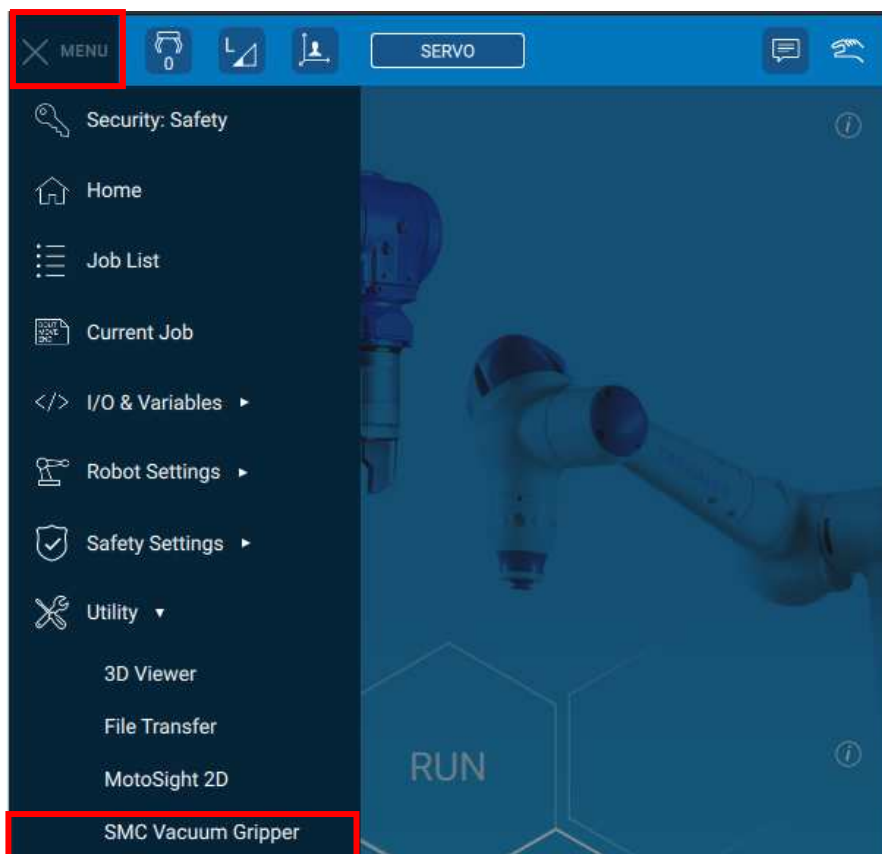

2. Utility Window Features

(1) Test run

Manual operation of the vacuum gripper can be checked.

Tapping the GRIP/RELEASE button performs a vacuum gripping/vacuum release operation.

Blow time at release

Sets the time to supply vacuum release pressure when the RELEASE button is tapped.

The default value is 0.1 sec and can be set in the range of 0 to 1 sec.

(2) Sensor Signal Monitor

The presence or absence of a pressure switch response can be checked.

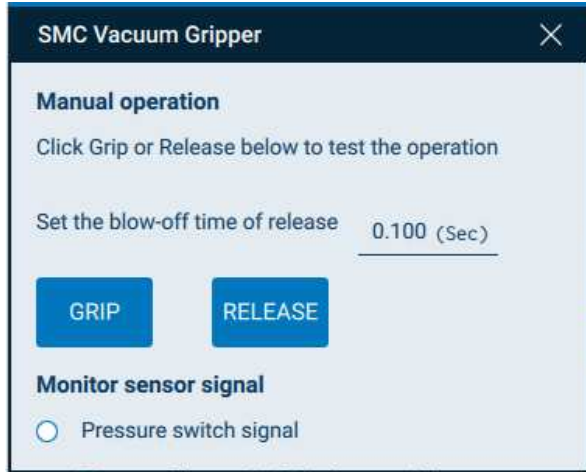

4.4.4. YASKAWA plug & play kit - Vacuum Gripper Integration Window

1. On the Job Contents View screen, tap [GRIPPER] on the navigation bar to open the Vacuum Gripper Integration Window.

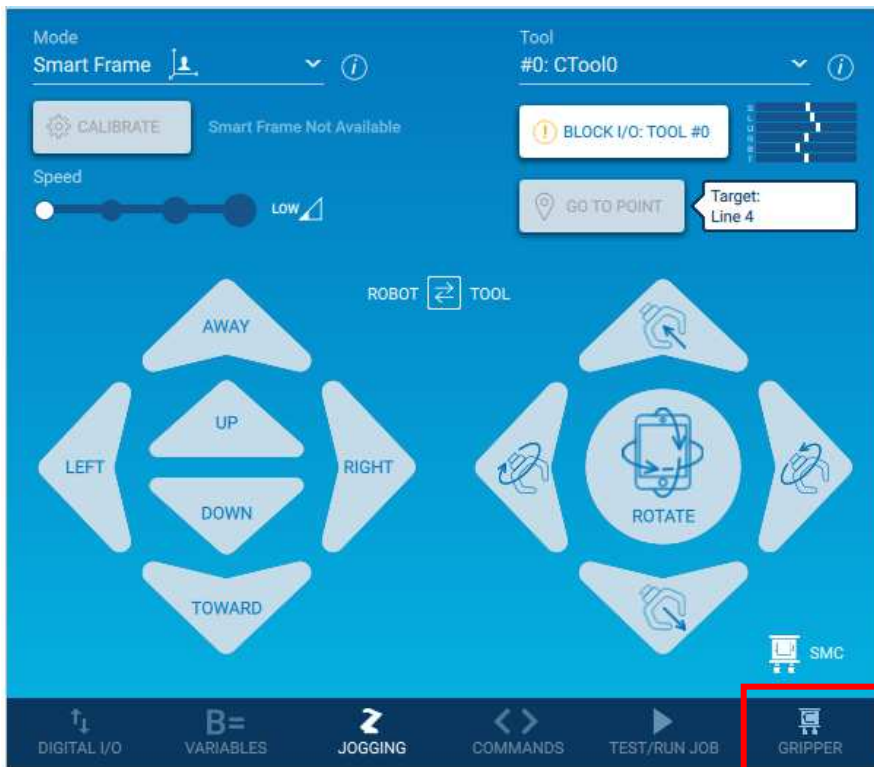

2. Add Command Tab

(1) Operation Selection

Select the behavior of the gripping operation.

A) Gripping only

The gripping operation is performed. At this time, "Successful gripping " is assumed without checking the pressure switch signal, and the next operation is performed.

B) Gripping and signal monitoring

The gripping operation is performed. Before proceeding to the next operation, the pressure switch signal input is monitored to confirm. After checking gripping, and proceed to the next operation.

Gripping error detection time setting

Sets the maximum time to monitor the pressure switch signal input during gripping operation. If the pressure switch signal is turned on within the set time, it is judged as " gripping success"; if not, it is judged as " gripping failure.

C) Release only

Release operation and proceed to the next operation.

Blow time setting at release

Sets the time to supply vacuum release pressure during release operation.

The default value is 0.1 sec and can be set in the range of 0 to 1 sec.

(2) Add command

Commands can be added to a job to control the gripper's gripping /release operation.

A) SMC_GRIP_VACUUM

This command is used to initiate the vacuum gripper gripping operation.

This command is added when you select " Gripping only" or " Gripping and signal monitoring" in the operation selection.

B) SMC_RELEASE_VACUUM

This command is used to vacuum release the vacuum gripper.

In this case, the pressure switch signal is not monitored.

This command is added when Release only is selected in the operation selection.

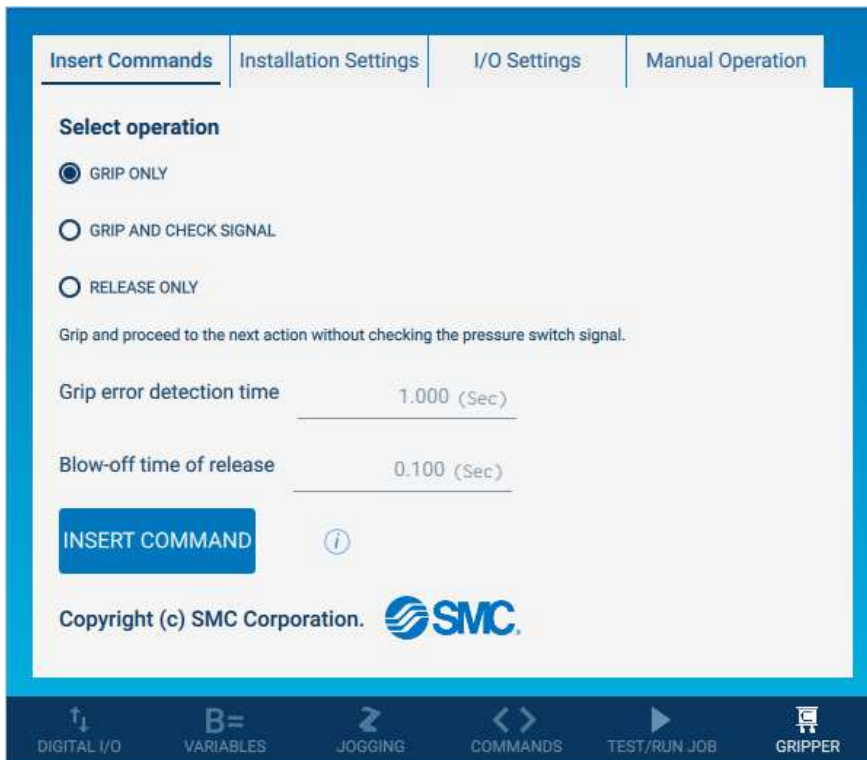

3. Basic Settings Tab

*To change the setting, set the security access level to the administrative level.

(1) Output status signal to digital output port

Selects whether to output a status signal to the digital output port when "Success" or "Failure" of gripping is detected.

When selected: Enabled

When the digital output port selection operation is enabled and either "gripping success" or "gripping failure" is detected, the corresponding digital output port is turned on.

When disabled selected:

When the digital output port selection operation is disabled, no status signal is output even if either "gripping success" or "gripping failure" is detected.

(2) Select digital output port

When "Output status signal to digital output port" is enabled, the operation of the select box becomes effective. Select the digital output port to output a status signal when "Success" or "Failure" of gripping is detected.

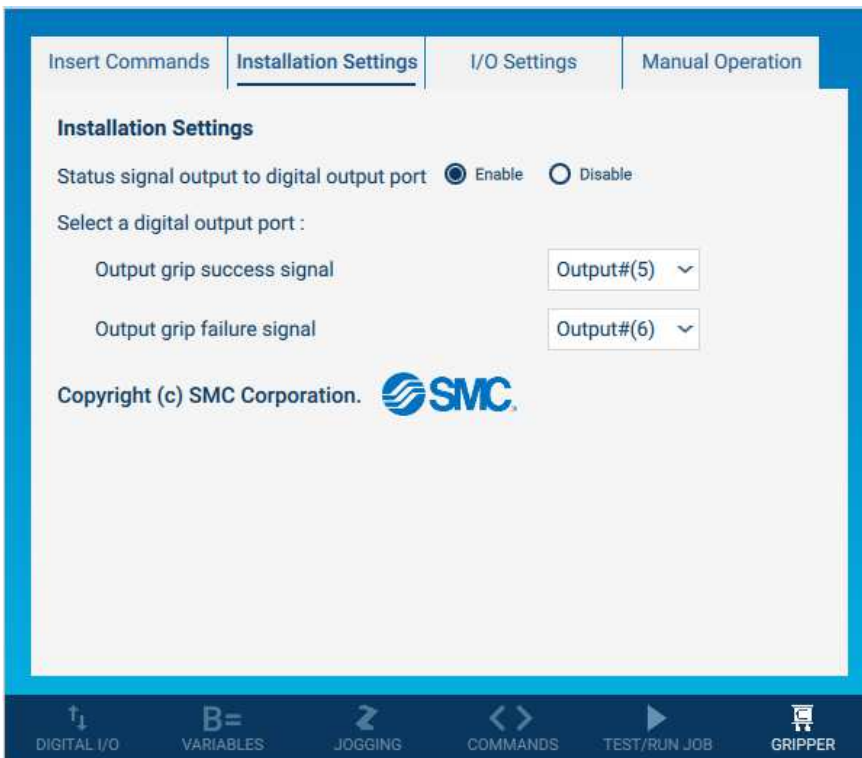

4. I/O Settings Tab

*To change the setting, set the security access level to the administrative level.

(1) I/O configuration for gripper operation

The I/O assignments are already set when the YASKAWA plug & play kit is installed, so as long as the wiring is done according to the manual, it can basically be used as is.

However, if the wiring is changed to connect with other devices, the signal settings for gripper operation can be changed from this tab.

If you wish to return the I/O settings to the same state as they were at the time of shipment, you can initialize them by pressing the button at the bottom of the screen.

(2) Set tool number

The collaborative robot calculates the external force by canceling the mass of the tool. Therefore, it is necessary to set the mass and center of gravity position of the tool or workpiece to be attached to the manipulator in the tool file.

By default, tool number 0 is selected when the grip button is pressed, and tool number 1 is selected when the release button is pressed. The tool number can be changed.



5. Test run tab

(1) Test run

Manual operation of the vacuum gripper can be checked.

Tapping the GRIP/RELEASE button performs a vacuum gripping /vacuum release operation.

Blow time at release

Sets the time to supply vacuum release pressure when the release button is tapped.

The default value is 0.1 sec and can be set in the range of 0 to 1 sec.

(2) Sensor Signal Monitor

The presence or absence of a pressure switch response can be checked.

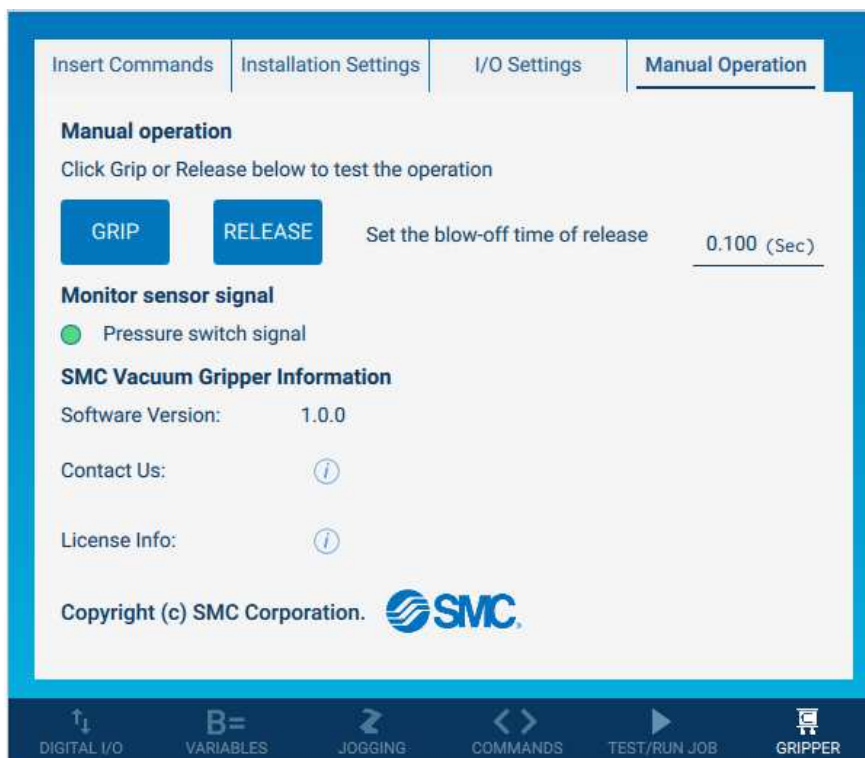

5. Dimensions

5.1. Vacuum gripper

5.1.1. In case of ZXP7*11

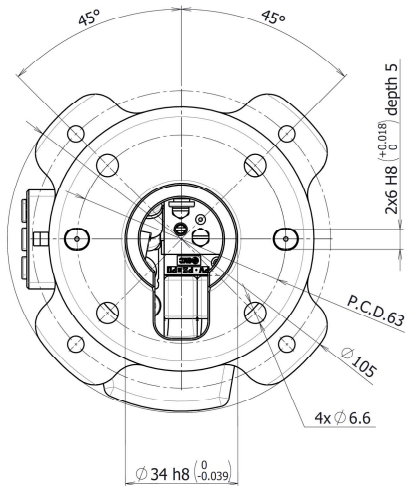

Details of internal parts

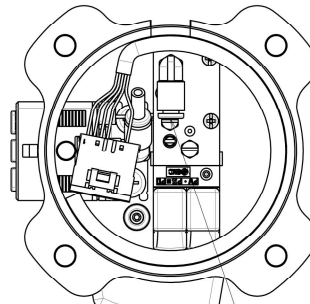

Air pressure supply (P) port
Applicable tubing O.D. Ø4

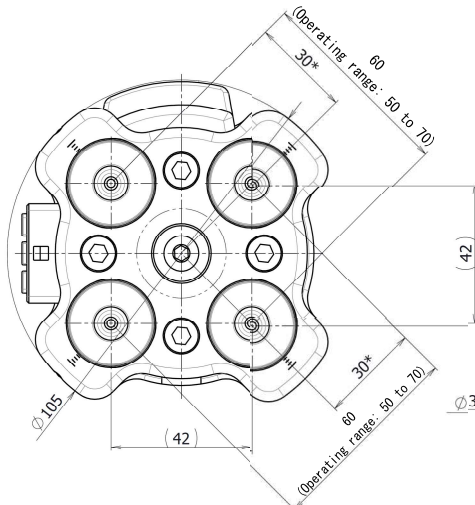
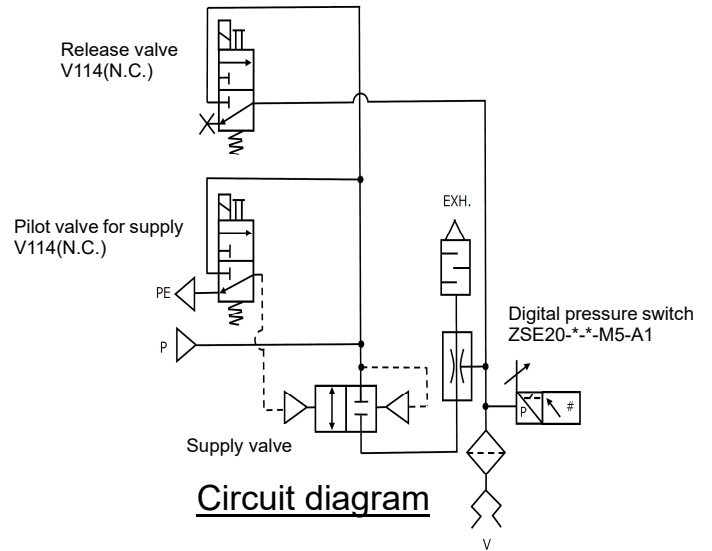
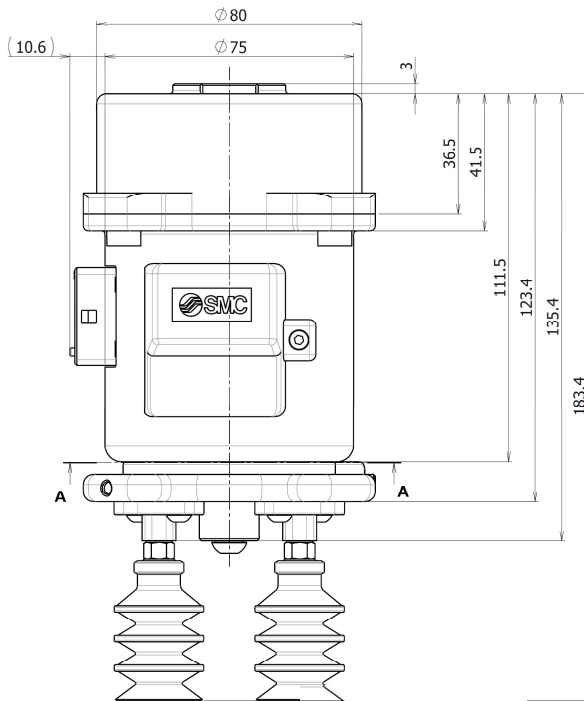

Without cup mounting flange

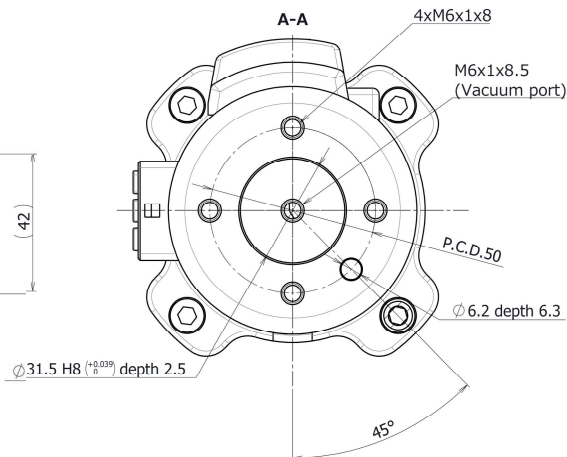

*Operating range: 25 to 35 (When a cup is mounted in the center)
As interference between cups may occur depending on the cup diameter according to the pitch to be used.

*Cup distance is changeable.

*The vacuum port doesn't come with mesh.

5.1.2. In case of ZXP7*12

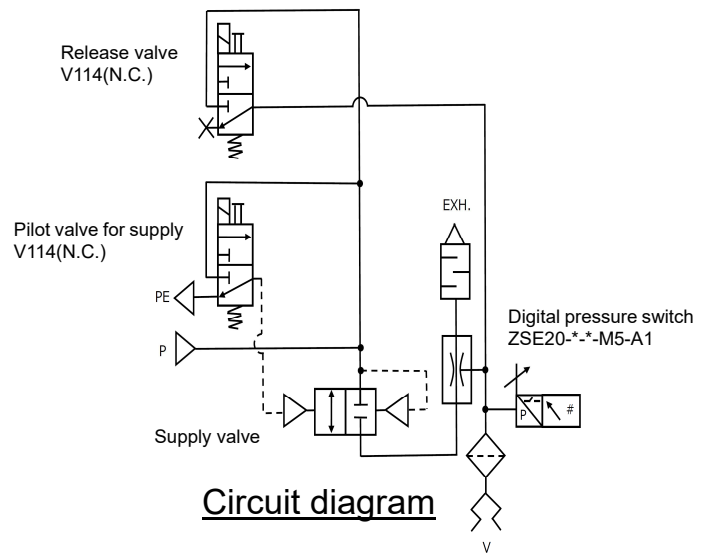
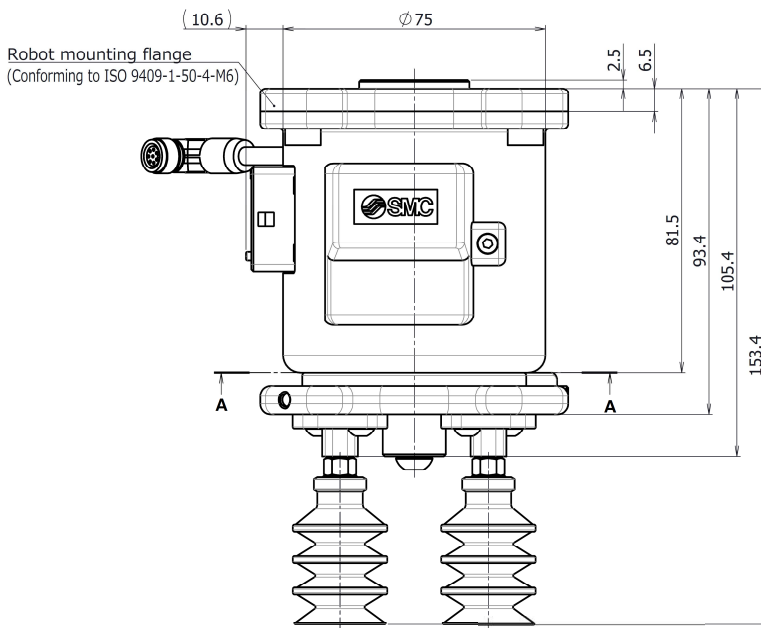
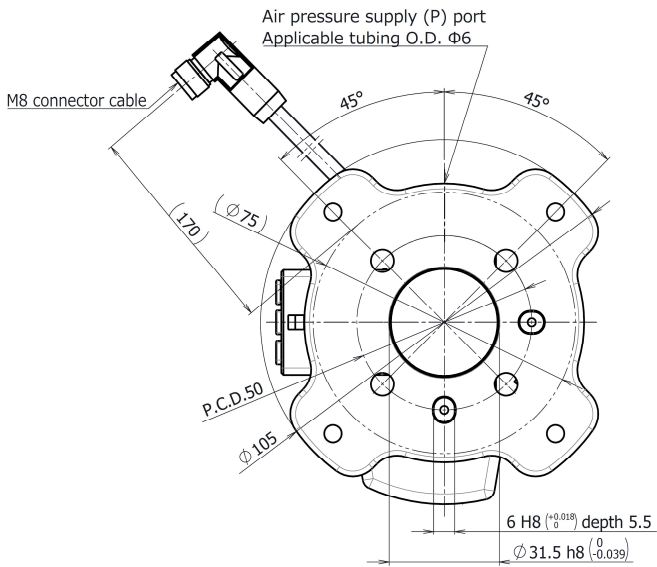

Without cup mounting flange

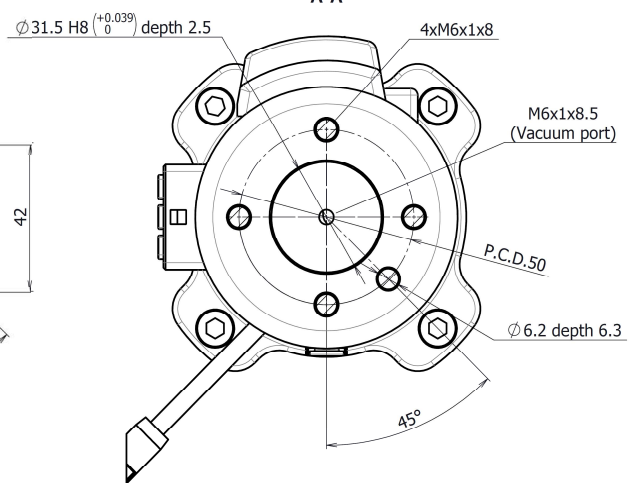
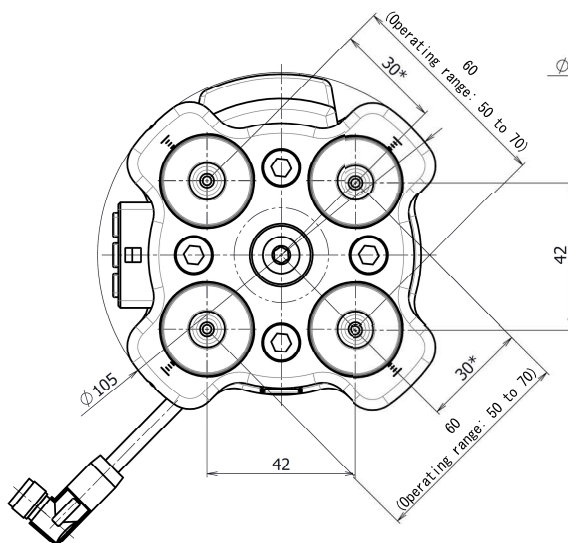

*Operating range: 25 to 35 (When a cup is mounted in the center)
As interference between cups may occur depending on the cup diameter according to the pitch to be used.

*The vacuum port doesn't come with mesh.

5.2. Center of gravity

5.2.1. In case of ZXP7*11 (ZXP7A11-ZPB25JN-X1)

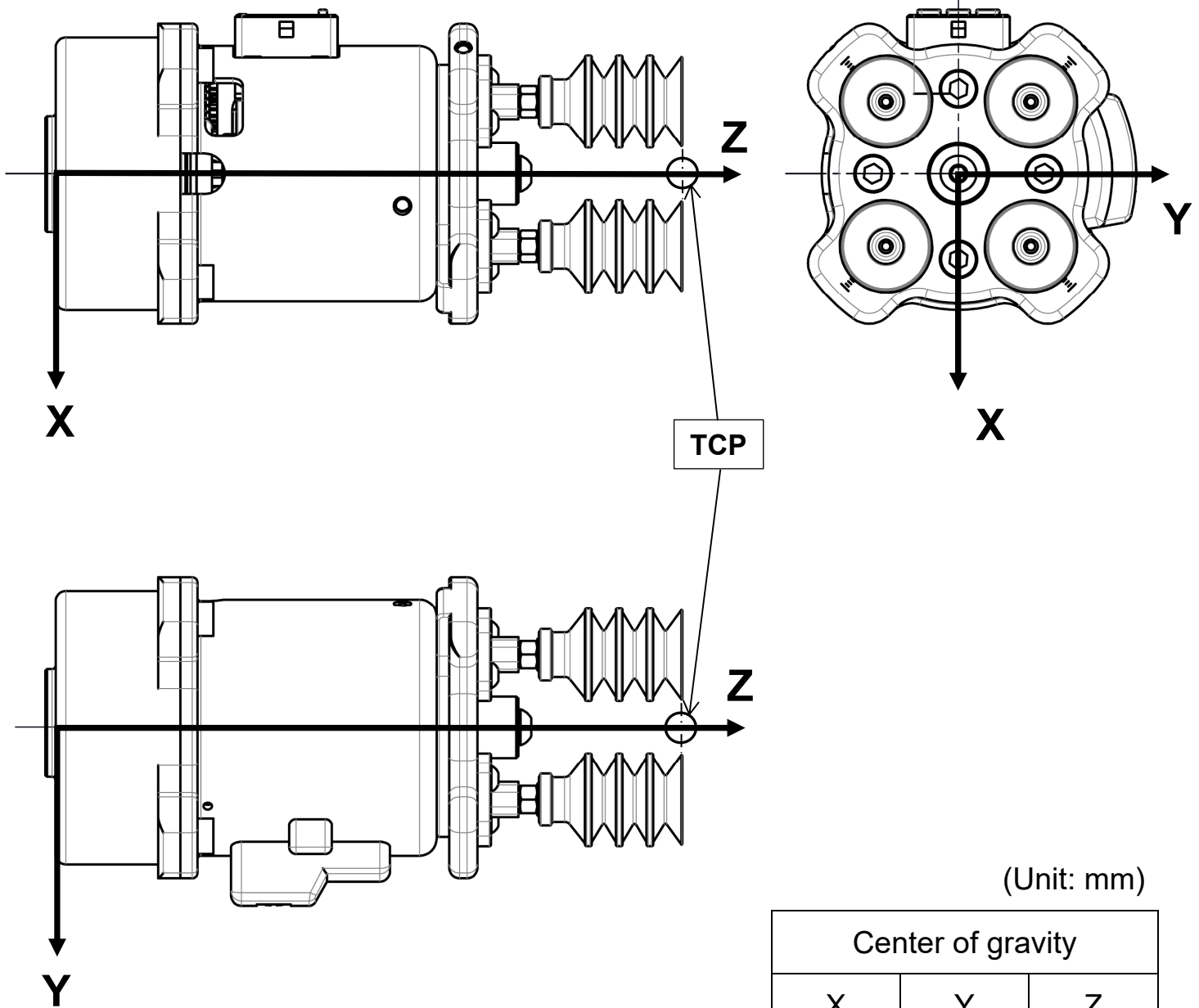

(Unit: mm)

Center of gravity		
X	Y	Z
-11.25	1.66	58.81
Tool Center Point (TCP) *		
X	Y	Z
0	0	183.4

* Refer to P.34 for the values when other suction cups with adapter are mounted.

Tool Center Point (TCP) for each suction cup

Model **ZXP7A11**

(4) **(5)** **(6)** **(7)** **(8)** -X1*

Unit: [mm]

Applicable cup

(4) Series	(5) Diameter	(6) Form	(7) Material	(8) Attachment	Tool Center Point(TCP)		
					X	Y	Z
ZP	08	U	*		0	0	150.9
ZP	08	B	*				151.9
ZP	10	UT	*				150.9
ZP	13	UT	*				150.9
ZP	16	UT	*				150.9
ZP	10	U	*				152.9
ZP	13	U	*				152.9
ZP	16	U	*				153.4
ZP	20	U	*				154.9
ZP	25	U	*				154.9
ZP	32	U	*				155.4
ZP	10	C	*				152.9
ZP	13	C	*				152.9
ZP	16	C	*				153.4
ZP	20	C	*				154.9
ZP	25	C	*				154.9
ZP	32	C	*				155.4
ZP	10	B	*				156.9
ZP	13	B	*				159.4
ZP	16	B	*				160.9
ZP	20	B	*				164.4
ZP	25	B	*				164.9
ZP	32	B	*				169.9
ZP	20	UT	*				150.9
ZP	16	J	*				164.9
ZP	B25	J	*				183.4
ZP	B30	J	*				189.9
ZP3P	20	JT2	SF				169.1
ZP3P	20	JT2	SF	M			169.1
ZP3P	32	JT2	SF				180.5
ZP3P	32	JT2	SF	M			180.5
ZP3P	20	JT5	SF				182.6
ZP3P	25	JT5	SF		186.4		
ZP3P	32	JT5	SF		200.9		

Note) Material symbol "N", "S", "U", or "F" is put in of the product number.

"*" in this table indicates the material symbol "N", "S", "U" or "F".

5.2.2. In case of ZXP7*12 (ZXP7A12-ZPB25JN-X1)

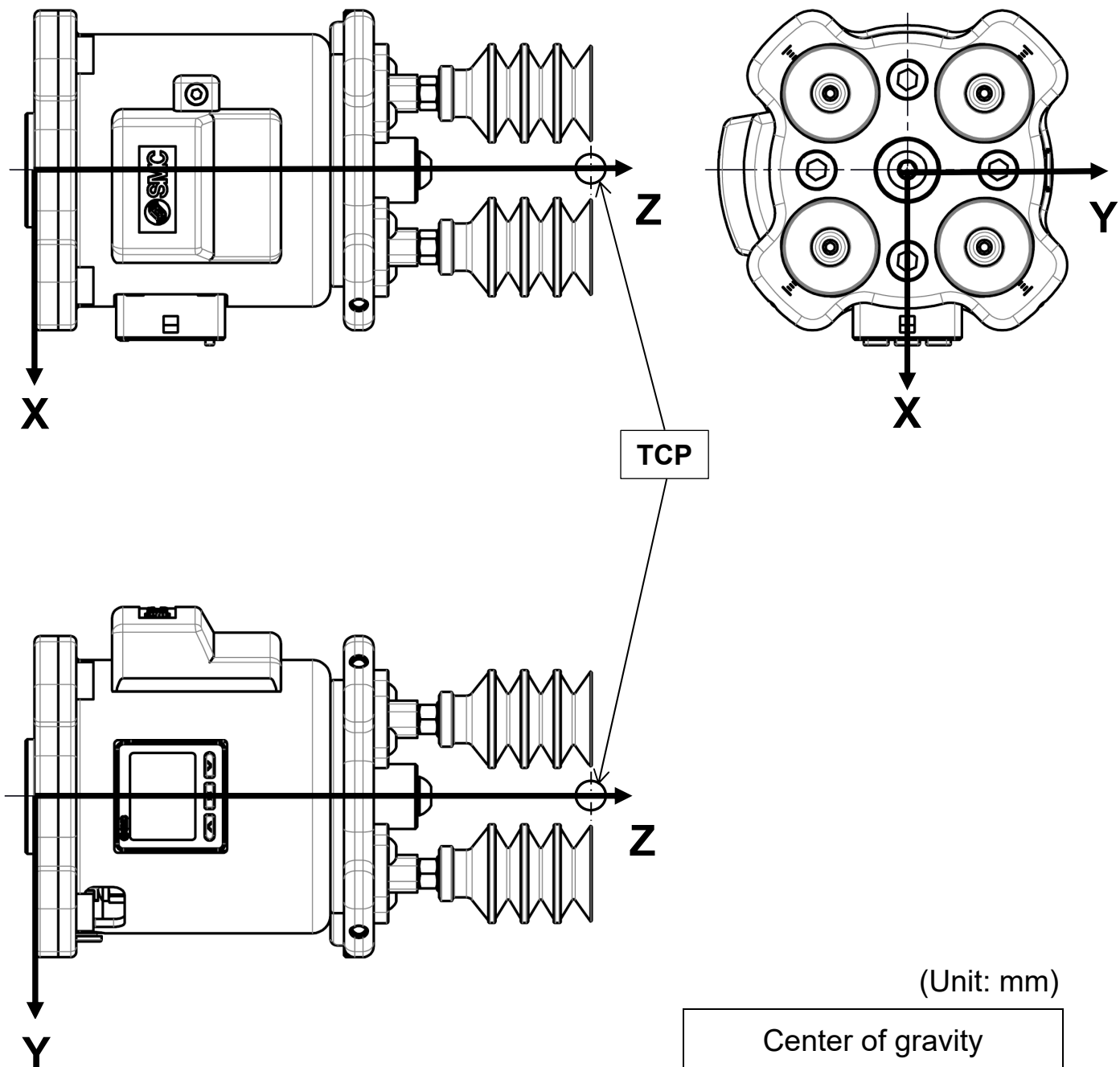

(Unit: mm)

Center of gravity		
X	Y	Z
0.92	0.29	56.32
Tool Center Point (TCP) *		
X	Y	Z
0	0	153.4

* Refer to P.36 for the values when other suction cups with adapter are mounted.

Tool Center Point (TCP) for each suction cup

Model **ZXP7A12** (4) (5) (6) (7) (8) -X1*

Applicable cup

Unit: [mm]

(4) Series	(5) Diameter	(6) Form	(7) Material	(8) Attachment	Tool Center Point(TCP)		
					X	Y	Z
ZP	08	U	*		0	0	120.9
ZP	08	B	*				121.9
ZP	10	UT	*				120.9
ZP	13	UT	*				120.9
ZP	16	UT	*				120.9
ZP	10	U	*				122.9
ZP	13	U	*				122.9
ZP	16	U	*				123.4
ZP	20	U	*				124.9
ZP	25	U	*				124.9
ZP	32	U	*				125.4
ZP	10	C	*				122.9
ZP	13	C	*				122.9
ZP	16	C	*				123.4
ZP	20	C	*				124.9
ZP	25	C	*				124.9
ZP	32	C	*				125.4
ZP	10	B	*				126.9
ZP	13	B	*				129.4
ZP	16	B	*				130.9
ZP	20	B	*				134.4
ZP	25	B	*				134.9
ZP	32	B	*				139.9
ZP	20	UT	*				120.9
ZP	16	J	*				134.9
ZP	B25	J	*				153.4
ZP	B30	J	*				159.9
ZP3P	20	JT2	SF				139.1
ZP3P	20	JT2	SF	M			139.1
ZP3P	32	JT2	SF				150.5
ZP3P	32	JT2	SF	M			150.5
ZP3P	20	JT5	SF				152.6
ZP3P	25	JT5	SF		156.4		
ZP3P	32	JT5	SF		170.9		

Note) Material symbol "N", "S", "U", or "F" is put in of the product number.

"*" in this table indicates the material symbol "N", "S", "U" or "F".

5.3. Suction cup with adapter

*It is shown here for representative model only. See the suction cup catalog for the other models.

Model : ZPG*U*-7A-X2
(Suction cup form : Flat type)

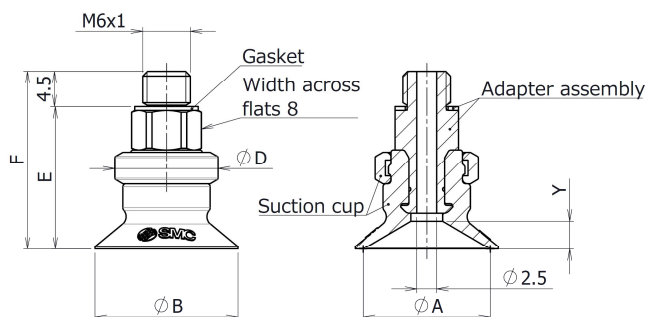

Dimensions

Model	A	B	D	E	F	Y
ZPG10U*-7A-X2	10	12	13	17.5	22	3
ZPG13U*-7A-X2	13	15		17.5	22	3
ZPG16U*-7A-X2	16	18		18	22.5	3.5
ZPG20U*-7A-X2	20	23	15	19.5	24	4
ZPG25U*-7A-X2	25	28		19.5	24	4
ZPG32U*-7A-X2	32	35		20	24.5	4.5

Model : ZPG*C*-7A-X2
(Suction cup form : Flat type with ribs)

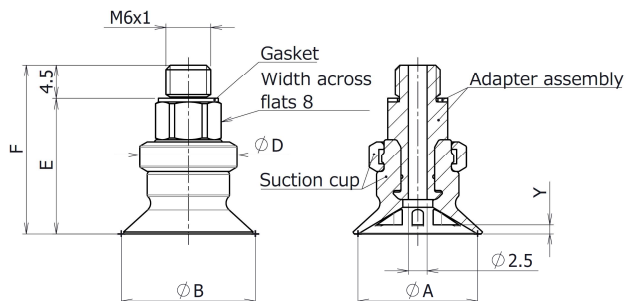

Dimensions

Model	A	B	D	E	F	Y
ZPG10C*-7A-X2	10	12	13	17.5	22	1.7
ZPG13C*-7A-X2	13	15		17.5	22	1.8
ZPG16C*-7A-X2	16	18		18	22.5	1.2
ZPG20C*-7A-X2	20	23	15	19.5	24	1.7
ZPG25C*-7A-X2	25	28		19.5	24	1.8
ZPG32C*-7A-X2	32	35		20	24.5	2.3

Model : ZPG*B*-7A-X2
(Suction cup form : Bellows type)

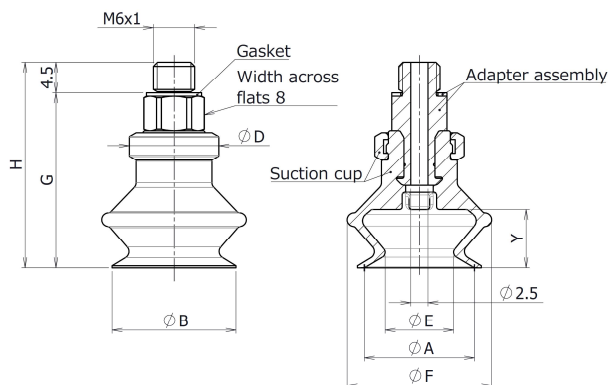

Dimensions

Model	A	B	D	E	F	G	H	Y
ZPG10B*-7A-X2	10	12	13	5.5	13.5	21.5	26	5.5
ZPG13B*-7A-X2	13	15		5.5	13.5	21.5	26	5.5
ZPG16B*-7A-X2	16	18		8.7	19	24	28.5	7.5
ZPG20B*-7A-X2	20	22	15	10	21	25.5	30	8.5
ZPG25B*-7A-X2	25	27		12.6	25	29	33.5	10.5
ZPG32B*-7A-X2	32	34		16	28	29.5	34	14

Model : ZPG20UT*-7A-X2
(Suction cup form : Thin flat type)

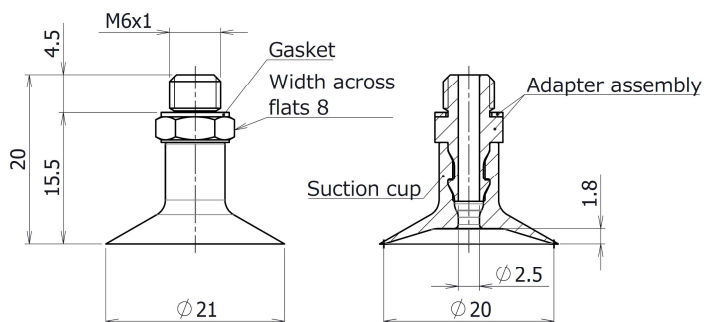

Model : ZPG16J*-7A-X2
 (Suction cup form : Multistage bellows type 2.5-Stage)

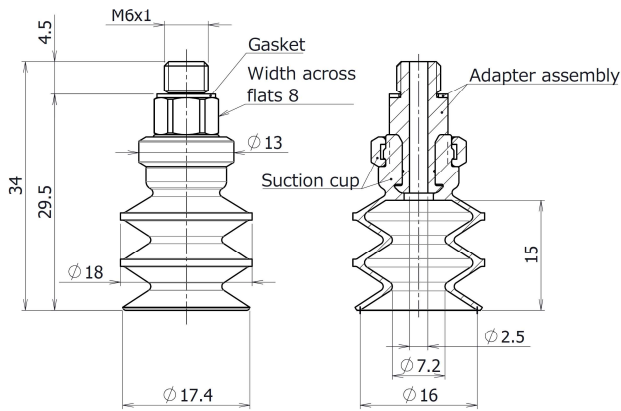

Model : ZPG(B25,B30)J*-7A-X2
 (Suction cup form : Multistage bellows type 3.5-Stage)

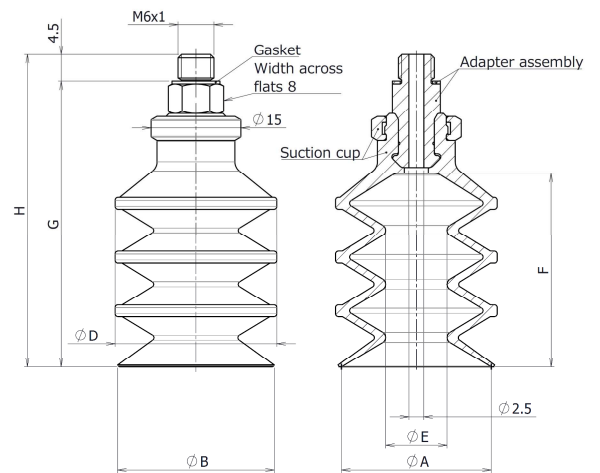

Dimensions

Model	A	B	D	E	F	G	H
ZPGB25J*-7A-X2	25	26	27	10.2	32.5	48	52.5
ZPGB30J*-7A-X2	30	33	32	13.8	38	54.5	59

Model : ZP3PG(20,25)JT5SF-7A-X2

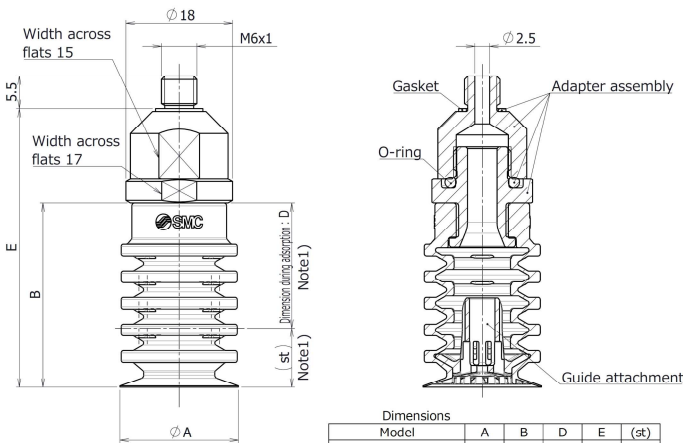

Model	A	B	D	E	(st)
ZP3PG20JT5SF-7A-X2	20	31.2	21.2	47.2	10
ZP3PG25JT5SF-7A-X2	25	35	23	51	12

Model : ZP3PG32JT5SF-7A-X2

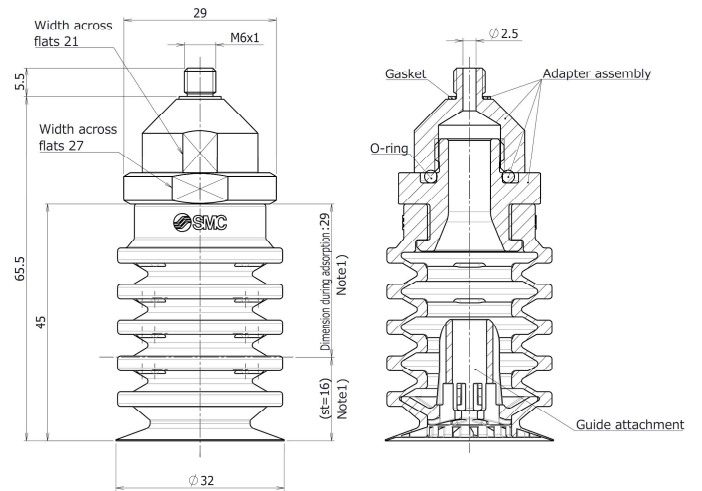

Note1) "D" and (st) indicate the reference value during gripping at vacuum pressure: -85[kPa].

6. How to change the number of cups

6.1 Change to 1 cup (with flange)

1. Removal of the cup.

- (1) Remove the suction cup with adapter from plate B using a spanner.
- (2) Loosen the bolt (M4 x 8), then remove plate B from plate A.
Be careful not to lose the O-ring.
- (3) Loosen the bolt for sealing (M6X8), then remove the cup from plate A.

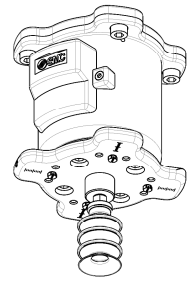

Completion drawing

2. Mounting of the plug and suction cup with adapter

- (1) Confirm the gasket seal in the accessory plug, then mount the plugs to plate A.
(4 places)
- (2) Confirm the gasket seal in the adapter, then mount the suction cup with adapter removed in the process (1) to plate A.

Reassemble the parts by reversing the disassembling process with specified tightening torque.

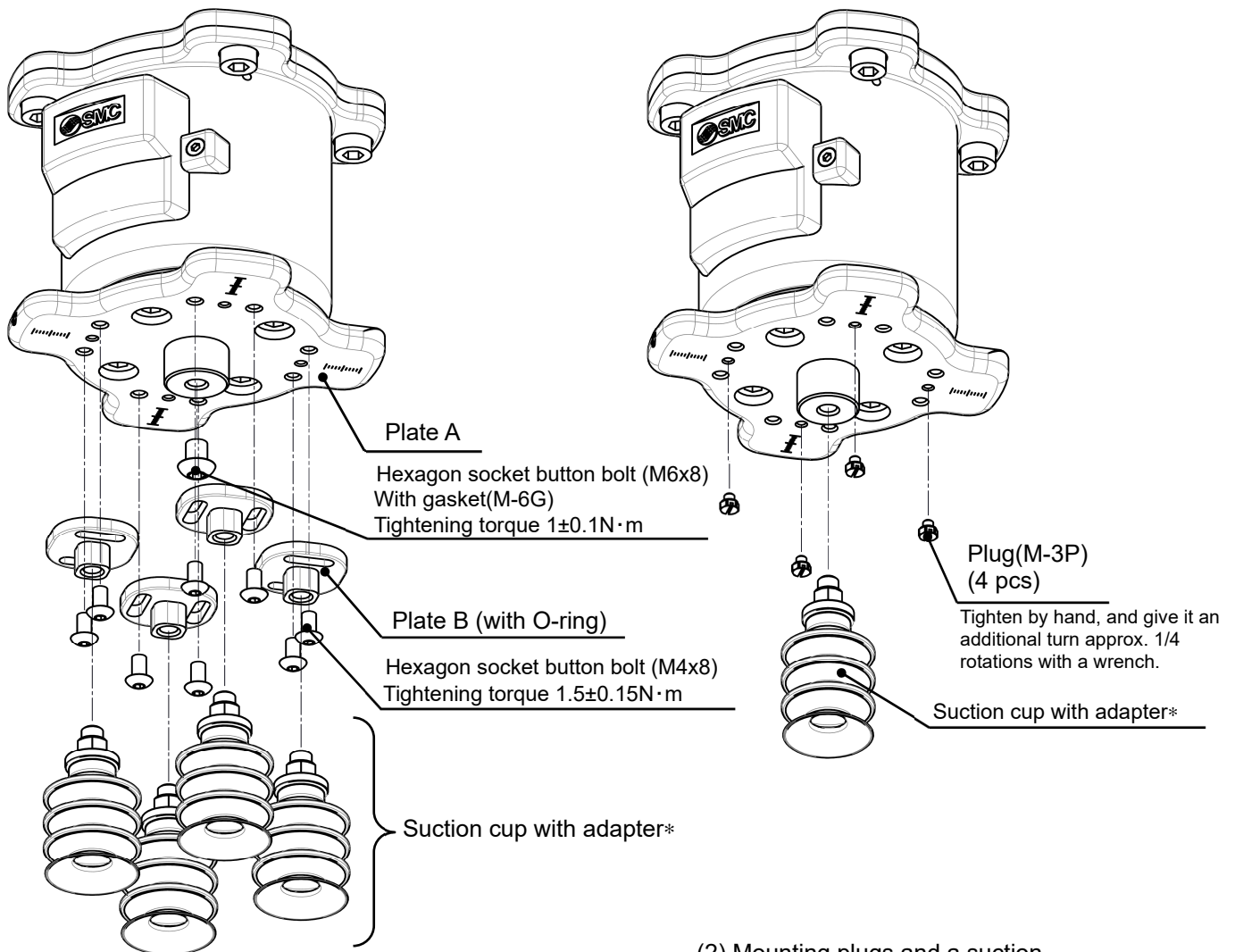

(1) Disassemble the suction cups with adapter

(2) Mounting plugs and a suction cup with adapter

Caution

- * Tightening torque: 1Nm, (As reference, tighten by 45 degrees using a spanner after tightening by hand)
If tightened excessively, thread portion may be damaged and gasket may be deformed. This will cause air leakage. Insufficient tightening may loosen the thread or cause air leakage.

6.2 Change to 1 cup (without flange)

*No mesh in the vacuum (V) port. If the mesh is necessary in the vacuum (V) port, use the vacuum gripper with cup mounting flange.

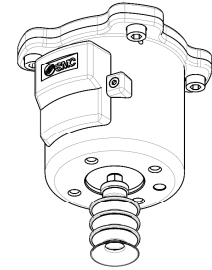

Completion drawing

1. Removal of the cup mounting flange

- (1) Loosen the bolt (M6x10), then remove the cup mounting flange.
Be careful not to lose the O-ring.
- (2) Remove the parallel pin.

2. Mounting of the suction cup with adapter

- (1) Remove the suction cup with adapter from the flange with cup removed in the process 1 above.
- (2) Confirm the gasket seal in the adapter, then mount the suction cup with adapter removed in the process (1) to the product.

Reassemble the parts by reversing the disassembling process with specified tightening torque.

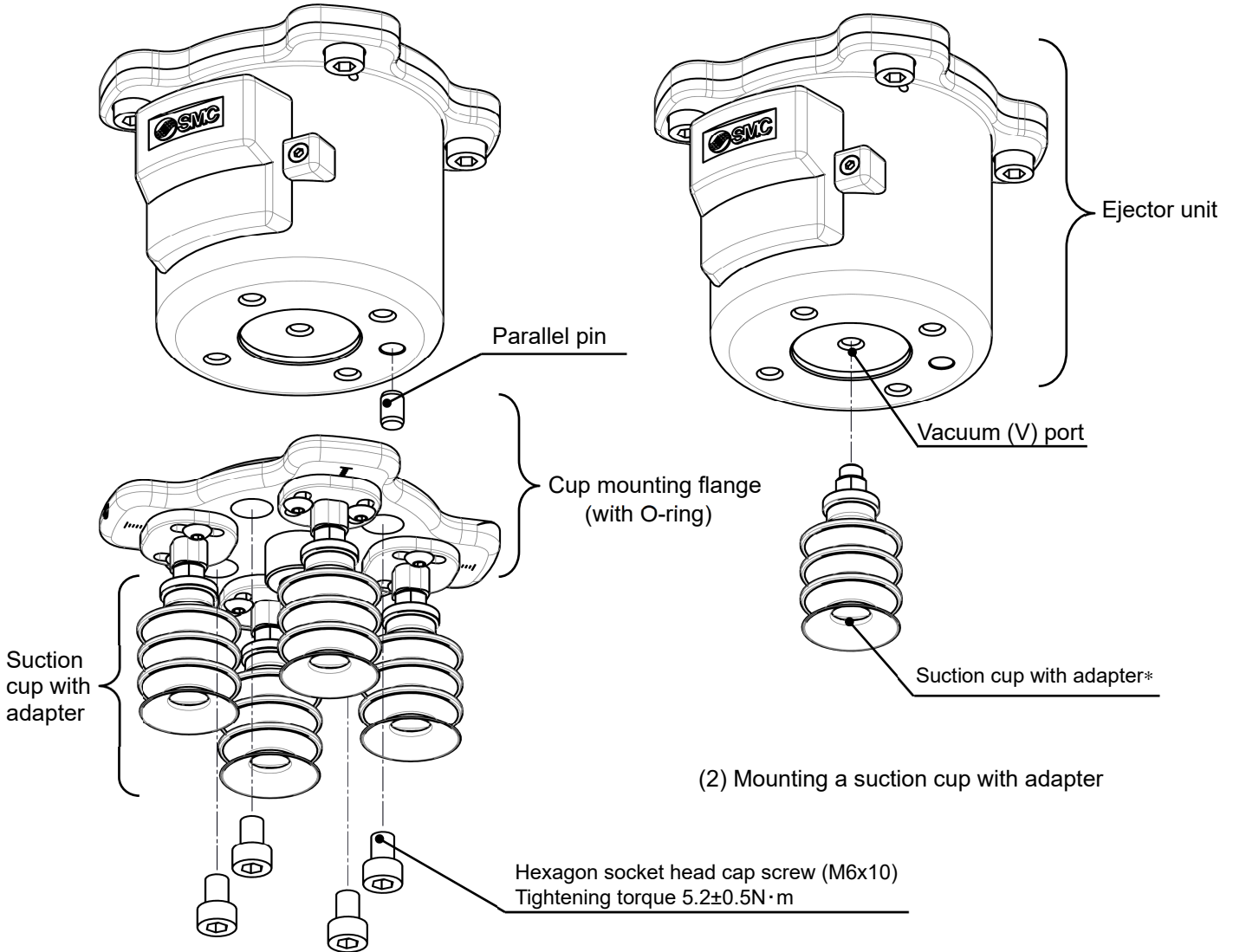

(1) Disassemble the cup mounting flange

(2) Mounting a suction cup with adapter

Caution

* Tightening torque: $1\text{N} \cdot \text{m}$, (As reference, tighten by 45 degrees using a spanner after tightening by hand))
If tightened excessively, thread portion may be damaged and gasket may be deformed. This will cause air leakage. Insufficient tightening may loosen the thread or cause air leakage.

6.3 Change to 2 cups

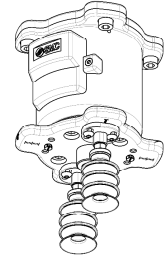

Completion drawing

1. Removal of the cup

- (1) Remove the suction cup with adapter from the plate B using a spanner.
- (2) Loosen the bolt (M4 x 8), then remove plate B from plate A.
Be careful not to lose the O-ring.

2. Mounting of the plug

- Confirm the gasket seal in the plug, then mount the plugs to plate A.
Reassemble the parts by reversing the disassembling process with specified tightening torque.

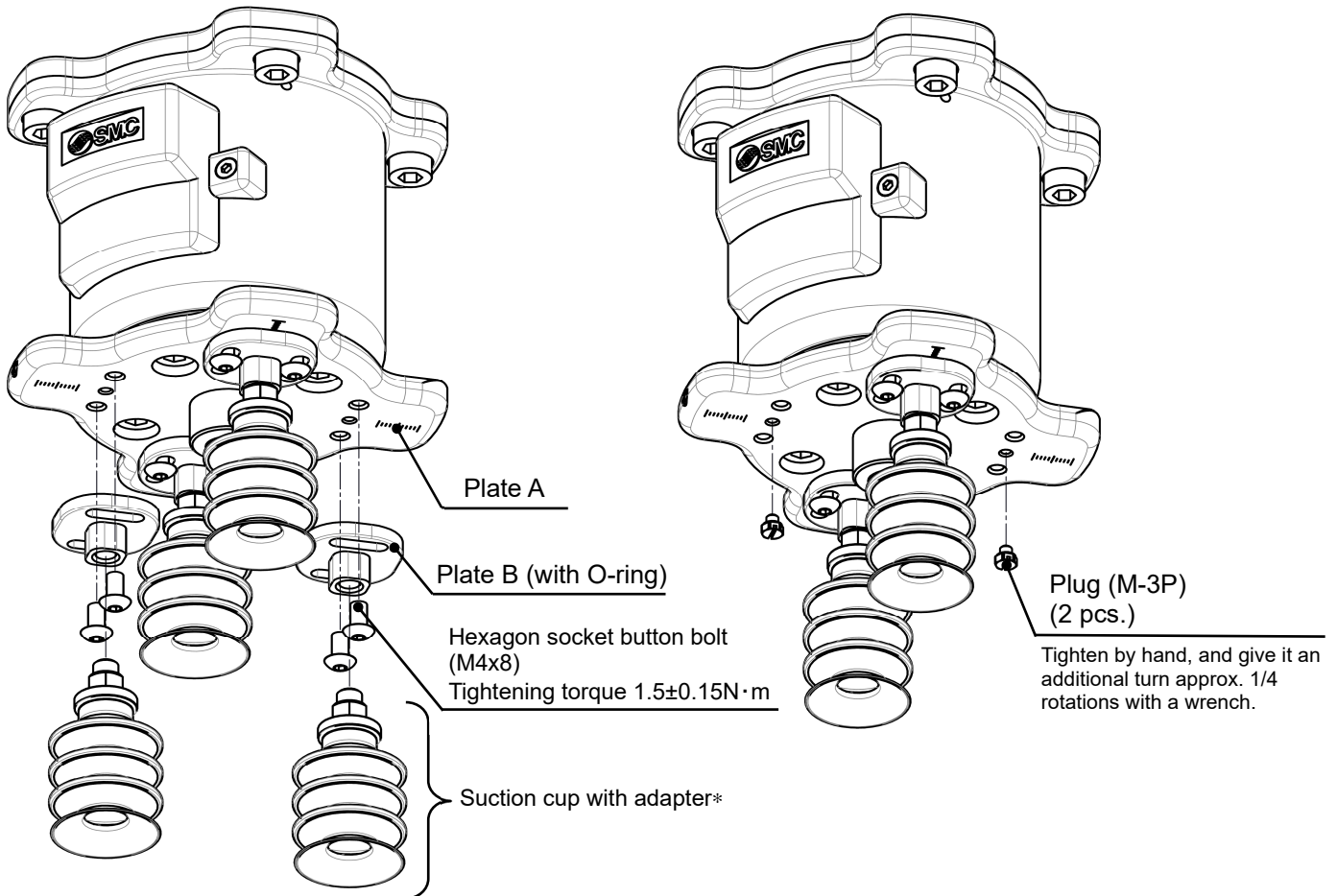

(1) Disassemble the suction cups with adapter

(2) Plug mounting

Caution

- * Tightening torque: $1\text{N} \cdot \text{m}$, (As reference, tighten by 45 degrees using a spanner after tightening by hand)
If tightened excessively, thread portion may be damaged and gasket may be deformed. This will cause air leakage. Insufficient tightening may loosen the thread or cause air leakage.

7. Maintenance

- Implement the maintenance and check shown below in order to use the vacuum gripper safely and in an appropriate way for a long period of time.

7.1. Maintenance for vacuum gripper

Caution

1) Check before and after the maintenance work

When the product is to be removed, turn off the power supply, and be sure to cut off the supply pressure and exhaust the compressed air. Confirm that the air is released to atmosphere.

When mounting the product after the maintenance work, supply compressed air, connect to the power, check if it functions properly and have a leakage inspection.

2) Maintenance should be performed according to the procedure indicated in the Operation Manual.

Improper handling can cause damage and malfunction of equipment and machinery.

3) Maintenance work

Compressed air can be dangerous when handled incorrectly. Therefore, in addition to observing the product specifications, replacement of silencer and other maintenance activities should be performed by personnel with sufficient knowledge and experience pertaining to pneumatic equipment.

4) Draining

Remove condensate from air filters and mist separators regularly. If the collected drainage is drained to the downstream side, it can stick inside of the product, causing operation failure and failure to reach the specified vacuum pressure.

5) Replace the silencer built into the vacuum gripper regularly.

It is recommended to replace the silencer when the pressure drop reaches 5kPa as a guideline. The replacement cycle varies depending on the operating conditions, operating environment and supply air quality. However, if there is a vacuum pressure drop and/or delay in the vacuum (gripping) response time which causes problem with the settings during operation, stop the operation of the product and replace the silencer regardless of the above mentioned replacement guideline.

-Part number for the silencer assembly for replacement: ZX1-HS1

< Silencer Assembly Replacement Procedure >

- Remove the cover.
- Loosen the 2 cross-recessed pan head screws to remove the silencer assembly.
- Assemble the new silencer assembly.
- Mount the cover.

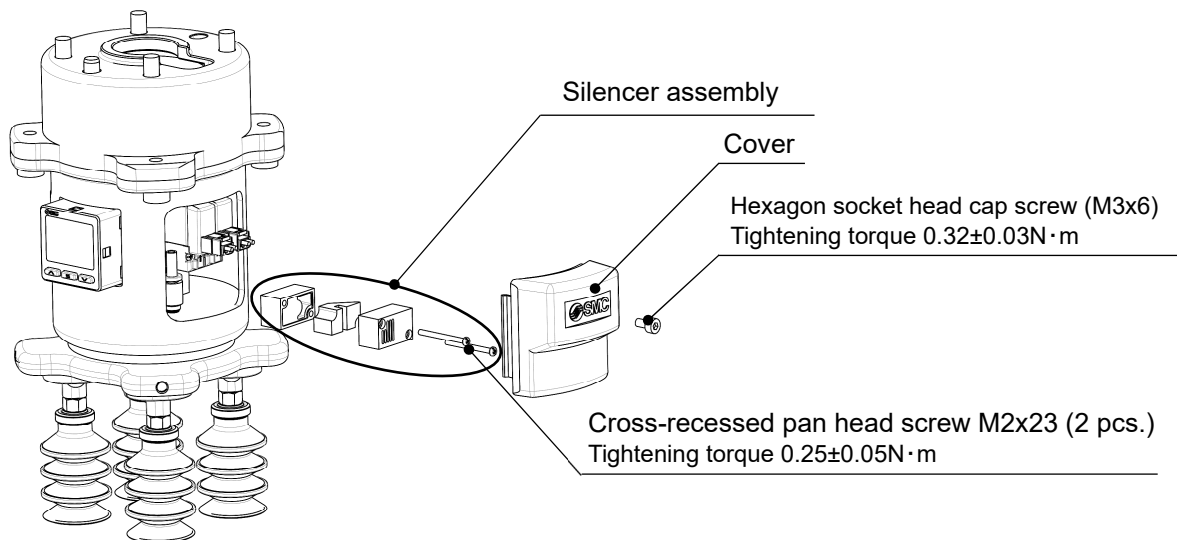

The figure shows ZXP7*11.

- 6) Do not disassemble or modify the product, other than the replacement parts specified in this manual.

7.2. Maintenance for suction cup

Caution

1) Suction cups are disposable. Replace them on a regular basis.

Continued use of suction cups will cause wear and tear on the gripping surface, and the exterior dimensions will gradually get smaller and smaller. As the cups' diameter gets smaller, their lifting force will decrease, though gripping will still remain possible.

It is extremely difficult to provide advice on the frequency of suction cup replacement. This is because there are numerous factors at work, including surface roughness, operating environment (temperature, humidity, ozone, solvents, etc.), and operating conditions (vacuum pressure, workpiece weight, pressing force of the suction cups on the workpieces, presence or absence of a buffer, etc.).

(The weakening of bent parts or the wear or sticking of rubber parts may occur with the bellows type cup.) Thus, the customer should decide when suction cups should be replaced, based on their condition at the time of initial use.

The adapter screw point may become loose depending on the operating conditions and environment. Be sure to perform regular maintenance.

<How to replace the suction cup>

- Pull the lock ring upward, and, after lifting it up to the adapter, remove the old cup by pulling it downward.
 - While holding the lock ring in the raised position place a new cup onto the adapter.
 - Confirm that the cup is securely in place, and then return the lock ring to its original position.
- * The cup without lock ring is just inserted to the end of the adapter.

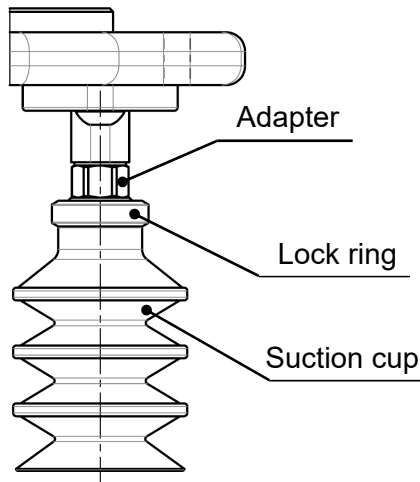

Cup assembly

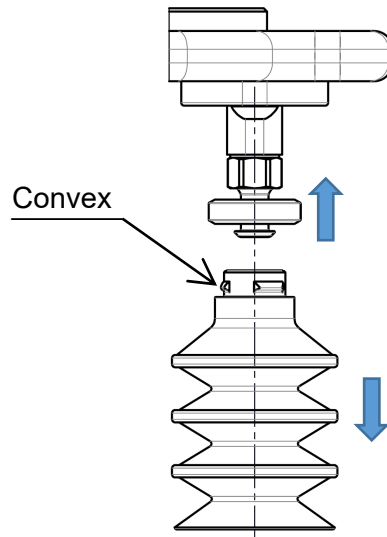

Cup disassembly

2) Mesh

If it is used in such a way that foreign matter is absorbed from the air or the workpiece, the mesh may become clogged. If the mesh is clogged, it will cause a reduction in the ejector performance. Clean the mesh periodically as necessary by washing, air blow and so on. If mesh clogging cannot be improved by cleaning, replace plate B.

•Part number for plate B for replacement : ZXP7-APL1-A-X1

Refer to "6.1 How to change to one cup (with flange)" for the replacement method.

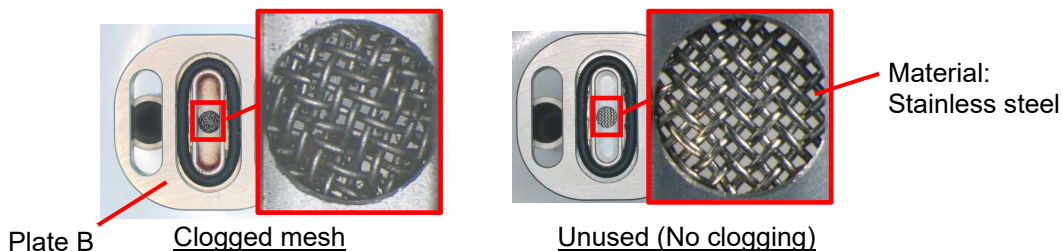

8. Precautions

8.1 Air supply

Warning

■ Use clean air.

It is recommended to use compressed air which purity class is 2:6:3 of ISO8573-1:2010. Supply air containing foreign matter, water, oil, condensate, etc., can cause malfunction of the supply valve and release valve. So, install air preparation equipment on the upstream side of the product (refer to the piping example below) and perform maintenance periodically to control the supply air properly.

Refer to "SMC Air Preparation System" for further details on compressed air quality.

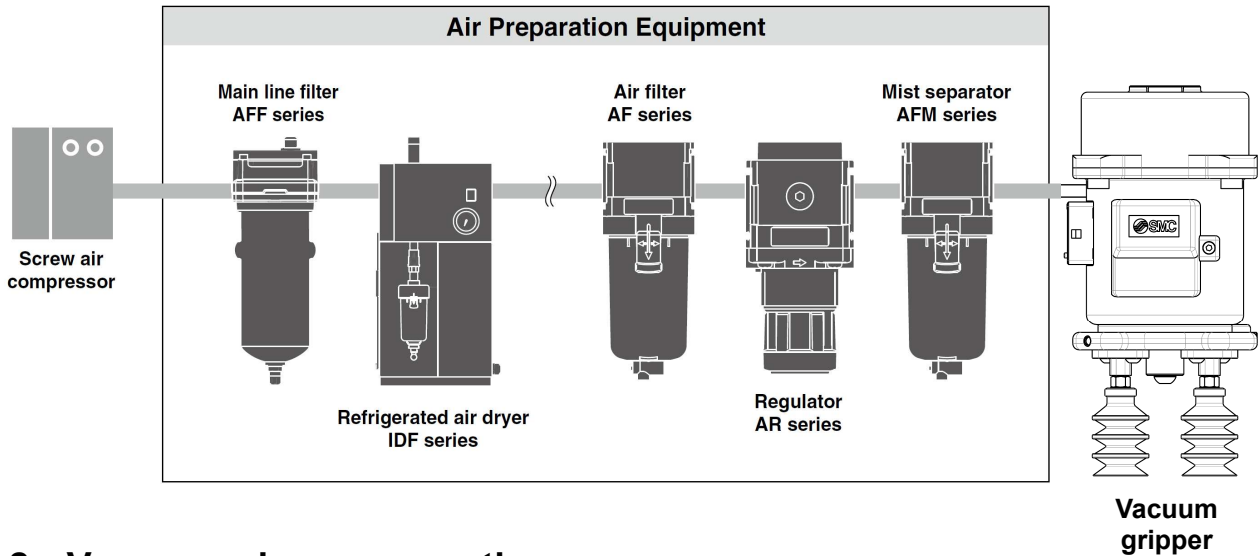

8.2 Vacuum gripper precautions

■ Designing

Warning

If power or air supply is shutdown, vacuum pressure may decrease and this product may drop a workpiece during gripping.

Please perform of safety measures by customer systems.

■ Mounting

Warning

1) Tighten to the specified tightening torque.

If the tightening torque is exceeded, the product, the mounting screws, brackets and the pressure switch can be broken. Insufficient torque can cause displacement of the product and the pressure switch from each proper position and loosening of the screw.

2) Hold the product itself when handling.

Do not pull the cable strongly or lift up the product by holding this cable. It can cause the malfunction of the product.

■ Wiring

Warning

1) Do not wire while energizing the product.

Doing so may result in damage to the internal parts of the solenoid valve or pressure sensor. In some cases, this damage may result in a malfunction.

2) Do not disassemble the cable or make any modifications, including additional machining.

Doing so may cause human injury and/or an accident.

Caution

1) Avoid repeatedly bending or stretching the cable as well as applying force to it.

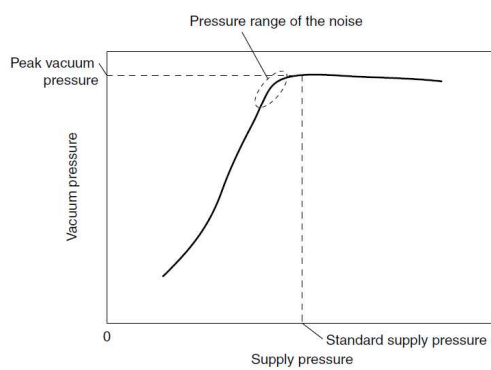

■ Workpiece

If water drops or dust are attached on the workpiece surface, they may go into the vacuum ejector and may cause the low vacuum performance. Also when workpieces are permeable, there is a case that sufficient lifting force cannot get. In such cases, it is necessary to perform a suction test to check the compatibility to your application before actual usage.

8.3 Suction cup precautions

■ Design

⚠ Warning

- 1) **In cases where the workpieces are heavy or dangerous objects, etc., take measures to address a possible loss of gripping force (installation of a drop prevention guide, etc.).**

In the case of transportation by vacuum gripping using suction cups, the gripping force is lost when there is a drop in vacuum pressure. Furthermore, since vacuum pressure can also deteriorate due to the wear and cracking of cups, vacuum leakage from piping, etc., be certain to perform maintenance on vacuum equipment.

■ Selection

⚠ Caution

- 1) **The cup materials which can be used differ depending upon the operating environment.**
An appropriate cup material should be selected. Furthermore, since suction cups are manufactured for use with industrial products, they should not come into direct contact with medicines, food products, etc.
- 2) **Depending upon the weight and shape of the workpieces, the diameter, quantity, and shape of cups suitable for use will vary.**

Refer to "3.3. How to calculate theoretical lifting force" for the theoretical lifting force. Also, the selectable cups will differ based upon conditions other than the above, such as the condition of the workpiece surface (presence or absence of oil or water), the workpiece material, and its gas permeability. Confirmation is necessary by actually performing vacuum gripping on the subject workpieces.

- 3) **Do not apply an impact or large force to a cup when gripping a workpiece.**
This will cause the deformation, cracking, and wear of the cup to be accelerated. The stiffening ribs, etc., should touch lightly, while staying within the cup skirt's deformation range. Positioning should be performed accurately, especially in the case of small-diameter cups.
- 4) **When transporting vertically, factors such as acceleration, wind pressure, and impact force must be considered in addition to the workpiece weight.**
Use caution particularly when lifting items such as glass plates and circuit boards because a large force will be applied by wind pressure. When a workpiece which is oriented vertically is transported horizontally, large forces are applied by acceleration when movement is started and stopped. Furthermore, in cases where the cup and workpiece can slip easily, accelerations and decelerations of horizontal movement should be kept to a minimum.
- 5) **When transporting flat shaped workpieces that have large surface areas using multiple cups, care must be taken in arranging the cups, so that the workpieces are evenly gripped.**
- 6) **Use caution since the workpiece could rotate during transfer.**
Use of more than one cup for each workpiece is recommended.

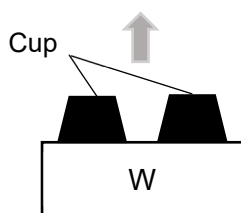

Horizontal lifting

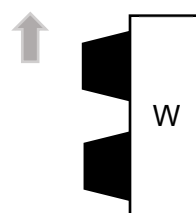

Vertical lifting
(This type of application should generally be avoided.)

■Gripping

This product has 4 pneumatically connected cups per ejector. If one cup fails to operate, all other cups cannot grip the object. Safety measures needs to be taken to prevent falling of workpiece during transfer of the object. When gripping with cups which do not grip object is required, connect the vacuum saving valve, ZP2V series (Applicable model: ZP2V-B6-05). The valve suppresses the decrease of the vacuum pressure and there is a case that the workpiece can be held.

For the feasibility of workpiece and conditions of customer, operation check with the actual equipment is required.

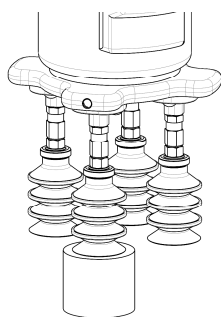
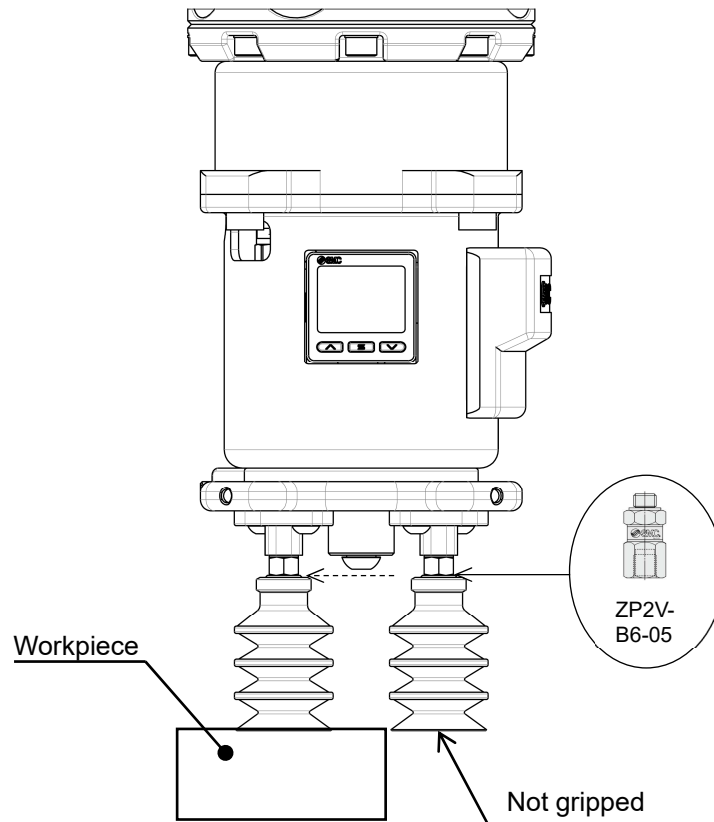

1 cup gripping

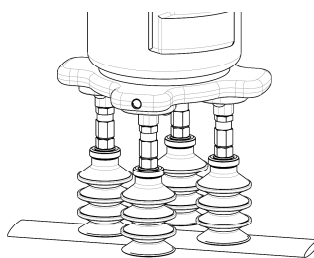

2 cups gripping

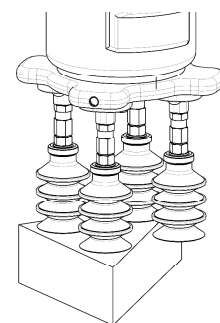

3 cups gripping

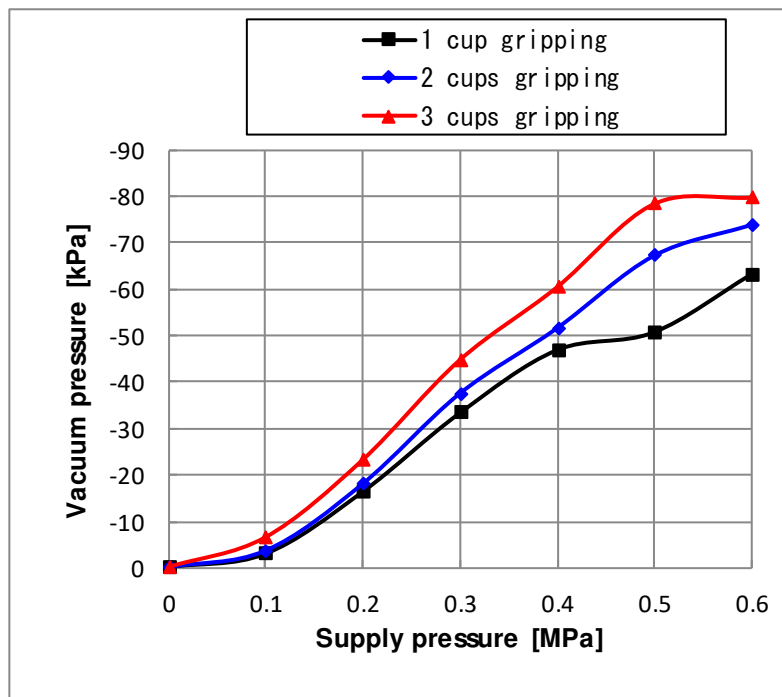

Exhaust Characteristics by using the vacuum saving valves: ZP2V-B06-05

* This data shows the data at the workpiece with no air leakage.

<Reference>

Theoretical lifting force of vacuum cup diameter 32mm with ZP2V-B06-05 at supply pressure 0.5 MPa

	Vacuum pressure [kPa]	Theoretical lifting force [N]	Horizontal lifting force [N] (Safety factor 1/4)
1 cup gripping	-50	40.2	10
2 cups gripping	-67	53.8	13.4
3 cups gripping	-73	58.7	14.6

(Calculated by "W = P X S, S = π · r², r = Φ32 / 2". Refer to 3.3 How to calculate theoretical lifting force for the detail.)

■ Storage

⚠ Caution

- 1) **It is recommended to store suction cups in the environment shown in the table below.**
Storing in an environment other than that recommended below may lead to changes in properties (deformation, discoloration, cracking, increased adhesiveness, etc.).

Recommended Storage Environment for Suction cups

Temperature	15 to 25[°C]
Humidity	50[%] or less, No condensation
Other	Location that is shaded from direct sunlight or fluorescent light Location without the presence of ozone (For NBR and conductive NBR)

9. Trouble shooting

Condition & Description of improvement	Contributing factor	Countermeasure
Initial gripping problem (During trial operation)	Gripping area is small. (Lifting force is lower than the workpiece mass.)	Recheck the relationship between workpiece mass and lifting force. - Use a suction cup with a large gripping area. - Increase the quantity of suction cups.
	Vacuum pressure is low. (Leakage from gripping surface) (Air permeable workpiece)	Eliminate (reduce) leakage from gripping surface. - Reconsider the shape of a suction cup. Check the relationship between suction flow rate and arrival pressure of vacuum ejector. - Increase gripping area.
	Inadequate supply pressure of vacuum ejector	Measure supply pressure in vacuum generation state. - Use standard supply pressure. - Reconsider compressed air circuit (line).
	Clogging of vacuum ejector (Infiltration of foreign matter during piping)	Remove foreign matter.
	The pressure just before the supply (P) port is low.	Depending on the piping volume (piping length and diameter), if the pressure just before the supply (P) port falls below 0.5MPa, the performance such as vacuum pressure may reduce. - Raise the upstream pressure, and the pressure just before the supply (P) port becomes 0.5MPa.
Late vacuum achieving time (Shortening of response time)	The set vacuum pressure for the suction verification is too high.	Set to suitable setting pressure.
Fluctuation in vacuum pressure	Fluctuation in supply pressure	Reconsider compressed air circuit (line). (Addition of a tank etc.)
	Vacuum pressure may fluctuate under certain conditions due to ejector characteristics.	Lower or raise supply pressure a little at a time, and use in a supply pressure range where vacuum pressure does not fluctuate.
Occurrence of abnormal noise (intermittent noise) from exhaust of vacuum ejector	Intermittent noise may occur under certain conditions due to ejector characteristics.	Lower or raise supply pressure a little at a time, and use in a supply pressure range where the intermittent noise does not occur.
Gripping problem over time (Gripping is normal during trial operation.)	Clogging of the silencer	Replace the silencer. Add a filter to supply (compressed) air circuit.
	Clogging of the mesh	Clean the mesh periodically as necessary by washing, air blow and so on or replacing plate B. Refer to "7.2 Maintenance for suction cup".
	Presence of foreign matter in the ejector.	Remove foreign matter. Replace the ejector Add a filter to supply (compressed) air circuit.
	Cup (rubber) deterioration, cracking, etc.	Replace cups. Check the compatibility of vacuum cup material and workpiece.
Workpiece is not released.	The increase of stickiness due to the wearing of the cup (rubber).	Replace cups. Check the compatibility of the cup material and workpiece.
	Vacuum pressure is too high.	Set the vacuum pressure to the minimum value necessary.

Revision history

Rev.A : Add Tool Center Point
Rev.B : Add applicable model
Rev.C : Wiring changes and additions
 Software addition
 Correction of "Center of gravity"
 Caution added
 Trouble shooting added

SMC Corporation

4-14-1, Sotokanda, Chiyoda-ku, Tokyo 101-0021 JAPAN

Tel: + 81 3 5207 8249 Fax: +81 3 5298 5362

URL <https://www.smcworld.com>

Note: Specifications are subject to change without prior notice and any obligation on the part of the manufacturer.
© 2021 SMC Corporation All Rights Reserved