

OPERATION MANUAL

VBAT-M46A

AIR TANK

VBAT05S1-U-X104 VBAT10S1-U-X104

Chinese Pressure Vessel Code Compliant Product

INDEX

- Description and specifications of the components
- Cautions for operation
- Connecting Air tank and Booster regulator
- Regular check

Thank you for choosing this SMC product. This operation manual provides essential information to ensure its optimum performance and lifespan. Please read it before using the product. Keep this manual accessible and refer to it if problems occur. Please refer to the latest catalogue, drawings and maintenance procedures for product configuration and specifications.

- Description and specifications of the components

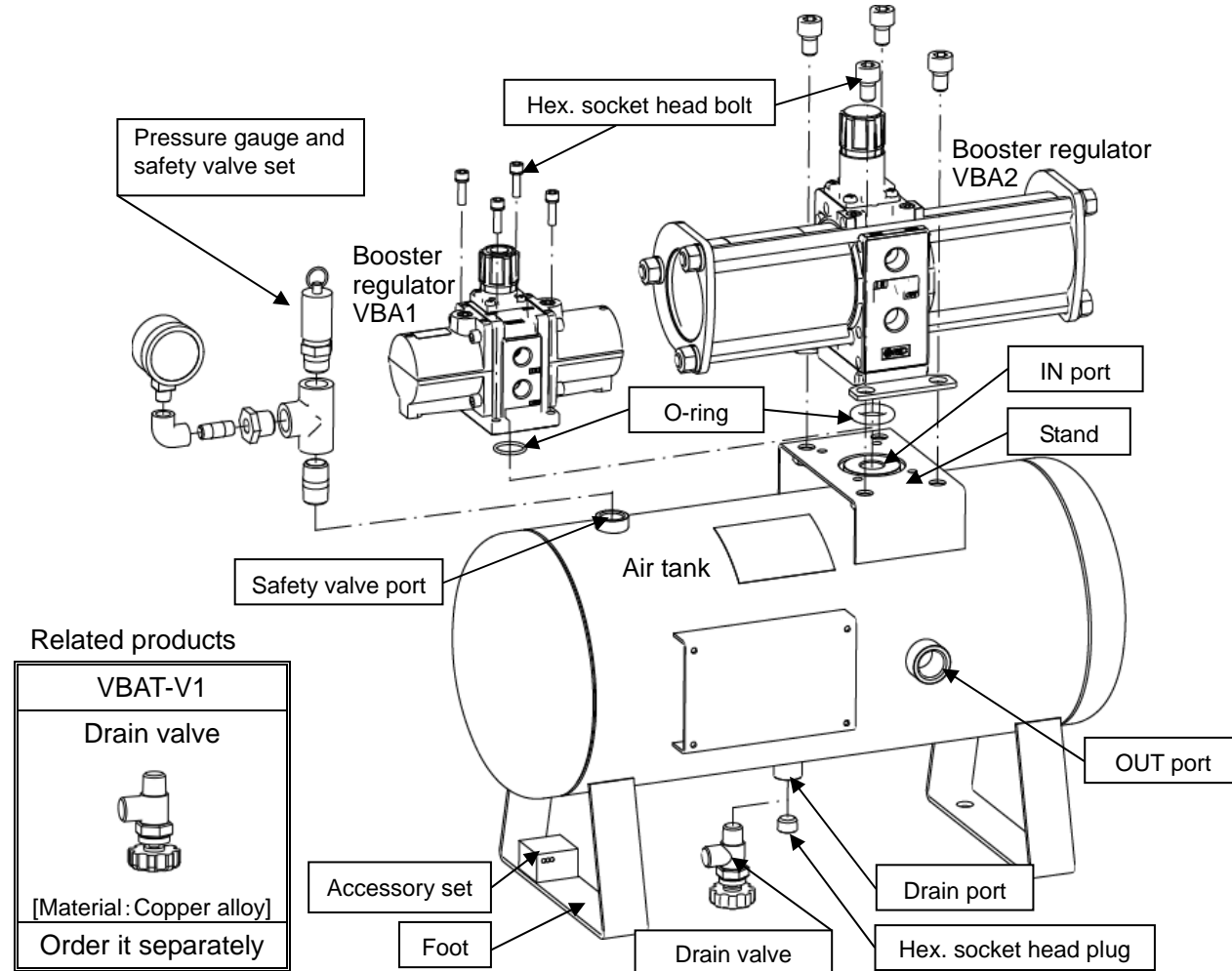

Table 1 Specifications

Model	VBAT05S1-U-X104	VBAT10S1-U-X104
Max. operating pressure	1.5 MPa	
Material	SUS304	
Tank capacity	5 L	10 L
Temp. range	0 to 75°C	
Tank mass	5.3kg	8kg
Port size	IN	3/8
	OUT	1/2
	Drain	1/4
External surface treatment	Acid cleaning	
Applicable booster regulator	VBA1	VBA1 / VBA2
Applicable standards	TSG R0003-2007 Supervision Regulation on Safety Technology for Simple Pressure Vessels	

Table 2 Accessories

Part name / Part No.	Components		
Accessory set VBAT5S-Y-4	Hex. socket head bolt	For VBA1 mounting	4 pcs.
	O-ring	For VBA1 mounting	1 pc.
	Hex. socket head plug	For Drain port	1 pc.
Pressure gauge and safety valve set VBAT-U	Safety valve		1 pc.
	Pressure gauge		1 pc.
	Piping components for tank connection		1 pc.
Operation Manual / VBAT-M46 Operation Manual / VBAT-M46C	Operation Manual (Japanese)		1 copy
	Operation Manual (Chinese)		1 copy
Product certificate	Certificate		1 copy
Accessory set VBAT10S-Y-4	Hex. socket head bolt	For VBA1 mounting	4 pcs.
		For VBA2 mounting	4 pcs.
	O-ring	For VBA1 mounting	1 pc.
Pressure gauge and safety valve set VBAT-U	Hex. socket head plug	For VBA2 mounting	1 pc.
		For drain port	1 pc.
	Safety valve		1 pc.
Operation Manual/VBAT-M46 Operation Manual/VBAT-M46C	Pressure gauge		1 pc.
	Piping components for tank connection		1 pc.
	Operation Manual (Japanese)		1 copy
Product certificate	Operation Manual (Chinese)		1 copy
	Certificate		1 copy

- Operating precautions

- To ensure safety and optimum operation, confirm the product's specifications before use. Operating product out of the scope of its specifications may cause failure or accident.

! WARNING

(1) Applicable standard

- This air tank conforms to laws and regulations in China. When this tank is used in countries outside of China, confirm that it is compliant with the laws and regulations of those countries.

As the air tank is compliant with "Regulations on Safety Supervision of Special Equipment", the following procedures are required when using the product. (Refer to "Regulations on Safety Supervision of Special Equipment Chapter 3" for details.)

- (1) To confirm that the pressure is set at the set value, submit the safety valve for air tank to the nearest Safety Inspection Bureau, and store the safety valve together with the Check ticket.
- (2) Before installing the air tank, inform the nearest Special Equipment Safety Supervision Department in writing.
- (3) When installing the air tank, it should pass the inspection performed by the Inspection and Measurement Agency authorized by the Special Equipment Safety Supervision Department based on the safety technical standard. [Documents supplied with the air tank, the Check ticket of the safety valve and the certificate supplied with the pressure gauge are necessary.]
- (4) Register the product and related documents with the Special Equipment Safety Supervision Department before using the device or within 30 days after starting to use the device.

(2) Operating pressure

- Use this air tank at maximum operating pressure of 1.5 MPa or less. Although the maximum operating pressure of the booster regulator VBA1*A is 2.0 MPa, please set it at 1.5 MPa or less when the booster regulator is used connected to this air tank.

(3) Connection

- Install a filter or mist separator on the OUT side of the air tank as necessary. This air tank does not guarantee cleanliness (this product is for general industrial use).

! CAUTION

- Consider the operating conditions, and use this air tank within the specification range.
- Do not supply or discharge air suddenly. This will cause the temperature to decrease due to air expansion, and the temperature may exceed the operating temperature limit of the air tank. If flow speed becomes faster, a loud noise may be generated by the friction inside the tube.
- When a booster regulator is used, select the appropriate product model according to the selection procedure of the energy saving program or How to Order in the catalog.

! CAUTION

Installation precautions

(1) Accessories

- Accessories are supplied attached to the foot of the tank with tie. Once removed, take care not to lose any of the parts.

(2) Installation

- Operate the air tank fixed.
- To mount the air tank on a floor surface, use the four holes of φ11 to secure the tank with bolts or anchor bolts (ordered separately).
- Mount the air tank horizontally. If the tank is mounted vertically, the load will be concentrated on one foot, leading to breakage.
- If the air tank is used where there is vibration, it may lead to breakage of the feet and the body. Please take anti-vibration measures.
- A lot of energy builds up if high pressure is supplied to the air tank. If the air tank breaks and air is discharged, a large blast of air will be generated and is very dangerous. Install the air tank where operators or equipment will not be affected.
- When connecting a booster regulator with an air tank, refer to the procedure "Assembling the air tank and the booster regulator".

(3) Piping

- Connect piping so that the piping load and vibration are not applied to the tank socket.

(4) Safety valve

- Pressure setting cannot be changed as it is fixed.

(5) Drain valve

- The drain valve needs to be prepared by the user. SMC related product VBAT-V1 is available.

- Connecting Air Tank and Booster Regulator

(1) Accessory check: Check the items and the quantity of parts in the package shown in Table 2.

(Accessories are attached to the foot of the air tank.)

(2) Prepare tools: Prepare a hexagon wrench key. The hexagon wrench key

for VBA1 is with nominal size 4 and 6, for VBA2 with nominal size 8, and for the drain port with nominal size 6.

: Tighten the optional safety valve and drain valve with a monkey spanner.

(3) Change of the booster regulator OUT port plug

: Remove the hexagon socket head plug at the joint of the tank at the back side of the booster regulator. (Remove any sealing agent left on the thread.)

: Mount the hexagon socket head plug to the OUT port on the front of the booster regulator by applying the seal tape.

VBA1: Tightening torque of 12 to 14 Nm (R1/4)

VBA2: Tightening torque of 22 to 24 Nm (R3/8)

(4) O-ring

: Mount the O-ring in the groove on the joint of the tank at the back of the booster regulator.

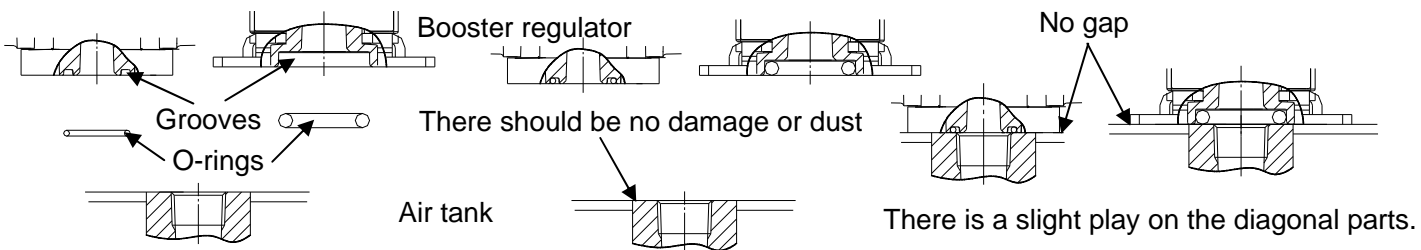

(5) Mounting direction: When mounting the booster regulator VBA2 to the air tank VBAT10S1-*, the direction of IN of the booster regulator and OUT of the air tank can be changed to suit the application. Align the direction of the booster regulator IN port and the air tank OUT port when mounting the booster regulator VBA1.

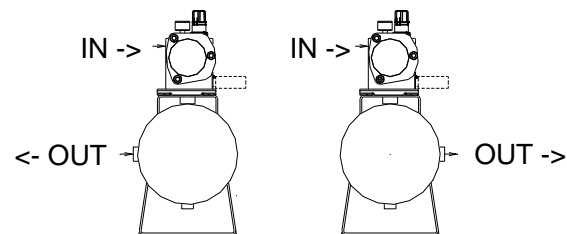

(6) Installation: Tighten diagonally with the hexagon socket head bolts included in the package.

VBA1: Tightening torque: 3 Nm (M5)

VBA2: Tightening torque: 24 Nm (M10)

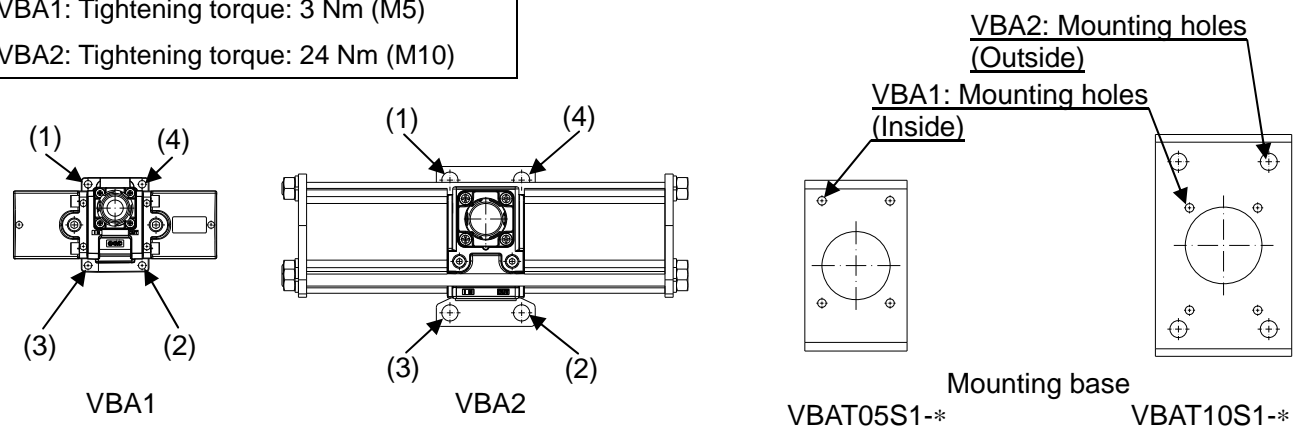

Assembly dimensions

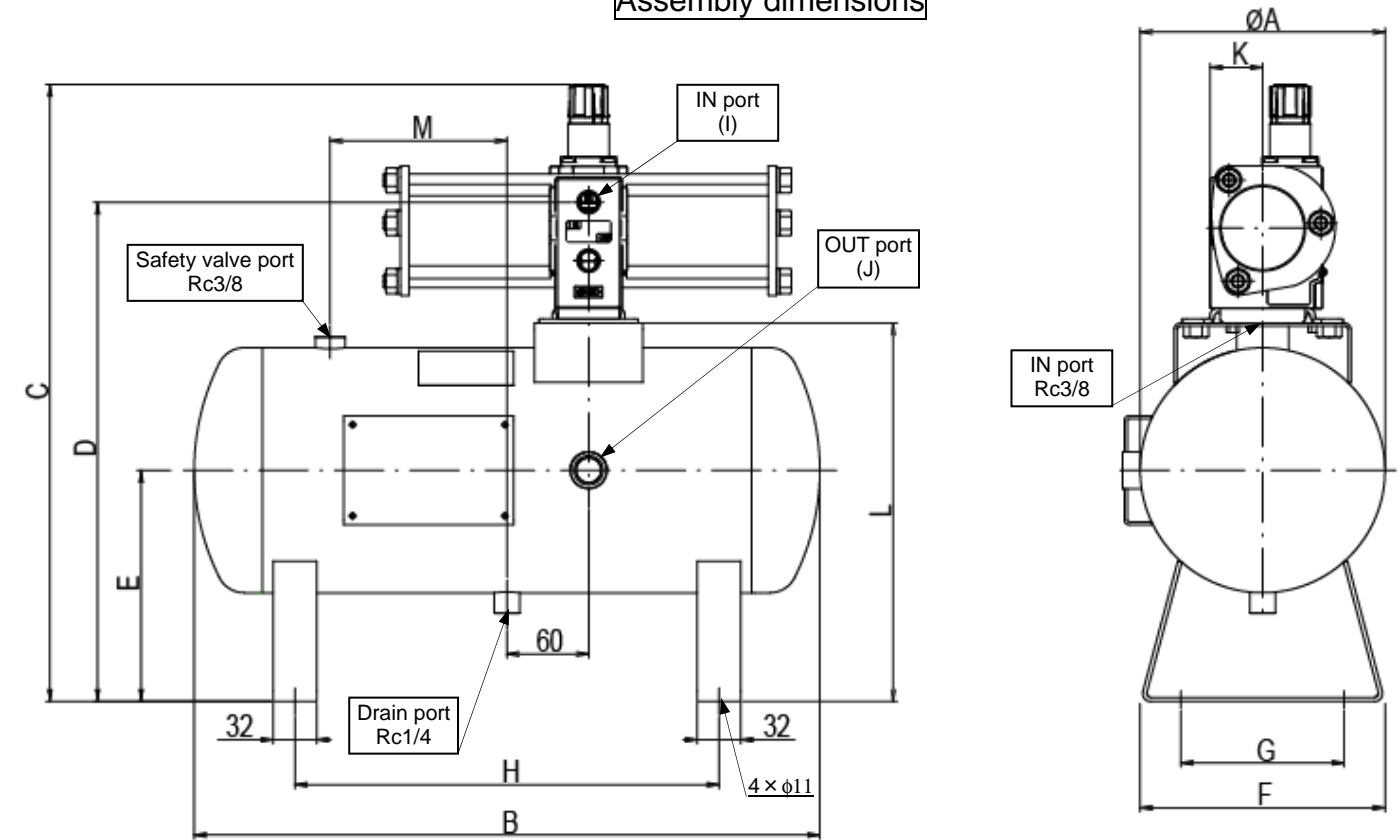

Air tank	Booster regulator	φ A	B	C	D	E	F	G	H	I	J	K	L	M
VBAT05S1	VBA10A VBA11A	150	337	370	307	163	160	100	200	Rc 1/4	Rc 3/8	20	257	60
VBAT10S1	VBA10A VBA11A	180	460	391	328	170	180	120	312	Rc 3/8	Rc 1/2	39	278	130
	454 417			367										

- Maintenance

⚠ WARNING

(1) Regular check

- The user of the air tank shall keep a record of maintenance by making a special equipment safety technical document.
- The use of a pressure vessel could lead to an unexpected accident due to external damage or internal corrosion caused by drainage. Therefore, make sure to check periodically for external damage, or the extent of internal corrosion through the port hole. An ultrasonic thickness indicator may also be used to check for any reduction in material thickness.

(2) Drain discharge

- If the product is used with a large amount of drainage, the drainage could flow out, leading to equipment malfunction or corrosion inside the tank. Perform drain flushing regularly.

SMC Corporation URL <http://www.smcworld.com>

Akihabara UDX 15F,

4-14-1, Sotokanda, Chiyoda-ku, Tokyo 101-0021, JAPAN

Phone: +81 3 5207 8249 Fax: +81 3 5298 5362

Specifications are subject to change without prior notice and any obligation the part of the manufacturer.

© 2008 SMC Corporation All Rights Reserved