



Operation Manual

PRODUCT NAME

High Vacuum L Type Valve

MODEL / Series / Product Number

XLH Series

SMC Corporation

Contents

Safety Instructions	-----	2
1. Product Specific Precautions 1 (Precautions on Design, Selection, Mounting, Piping, Wiring, Maintenance)	-----	4
2. Product Specific Precautions 2 (Maintenance parts)	-----	6
3. Specifications	-----	7
4. Construction and Outer dimensions	-----	9
5. Period and scope of warranty	-----	10
6. Parts replacement procedure	-----	11



Safety Instructions

These safety instructions are intended to prevent hazardous situations and/or equipment damage. These instructions indicate the level of potential hazard with the labels of “Caution,” “Warning” or “Danger.”

They are all important notes for safety and must be followed in addition to International Standards (ISO/IEC)*1), and other safety regulations.

- *1) ISO 4414: Pneumatic fluid power -- General rules relating to systems
- ISO 4413: Hydraulic fluid power -- General rules relating to systems
- IEC 60204-1: Safety of machinery -- Electrical equipment of machines (Part 1: General requirements)
- ISO 10218-1992: Manipulating industrial robots -- Safety



Caution

Caution indicates a hazard with a low level of risk which, if not avoided, could result in minor or moderate injury.



Warning

Warning indicates a hazard with a medium level of risk which, if not avoided, could result in death or serious injury.



Danger

Danger indicates a hazard with a high level of risk which, if not avoided, will result in death or serious injury.

Warning

1. The compatibility of the product is the responsibility of the person who designs the equipment or decides its specifications.

Since the product specified here is used under various operating conditions, its compatibility with specific equipment must be decided by the person who designs the equipment or decides its specifications based on necessary analysis and test results.

The expected performance and safety assurance of the equipment will be the responsibility of the person who has determined its compatibility with the product.

This person should also continuously review all specifications of the product referring to its latest catalog information, with a view to giving due consideration to any possibility of equipment failure when configuring the equipment.

2. Only personnel with appropriate training should operate machinery and equipment.

The product specified here may become unsafe if handled incorrectly.

The assembly, operation and maintenance of machines or equipment including our products must be performed by an operator who is appropriately trained and experienced.

3. Do not service or attempt to remove product and machinery/equipment until safety is confirmed.

1. The inspection and maintenance of machinery/equipment should only be performed after measures to prevent falling or runaway of the driven objects have been confirmed.

2. When the product is to be removed, confirm that the safety measures as mentioned above are implemented and the power from any appropriate source is cut, and read and understand the specific product precautions of all relevant products carefully.

3. Before machinery/equipment is restarted, take measures to prevent unexpected operation and malfunction.

4. Contact SMC beforehand and take special consideration of safety measures if the product is to be used in any of the following conditions.

1. Conditions and environments outside of the given specifications, or use outdoors or in a place exposed to direct sunlight.

2. Installation on equipment in conjunction with atomic energy, railways, air navigation, space, shipping, vehicles, military, medical treatment, combustion and recreation, or equipment in contact with food and beverages, emergency stop circuits, clutch and brake circuits in press applications, safety equipment or other applications unsuitable for the standard specifications described in the product catalog.

3. An application which could have negative effects on people, property, or animals requiring special safety analysis.

4. Use in an interlock circuit, which requires the provision of double interlock for possible failure by using a mechanical protective function, and periodical checks to confirm proper operation.



Safety Instructions

Caution

1. The product is provided for use in manufacturing industries.

The product herein described is basically provided for peaceful use in manufacturing industries. If considering using the product in other industries, consult SMC beforehand and exchange specifications or a contract if necessary.
If anything is unclear, contact your nearest sales branch.

Limited warranty and Disclaimer/Compliance Requirements

The product used is subject to the following “Limited warranty and Disclaimer” and “Compliance Requirements”.

Read and accept them before using the product.

Limited warranty and Disclaimer

1. The warranty period of the product is 1 year in service or 1.5 years after the product is delivered, whichever is first.*2)

Also, the product may have specified durability, running distance or replacement parts. Please consult your nearest sales branch.

2. For any failure or damage reported within the warranty period which is clearly our responsibility, a replacement product or necessary parts will be provided.

This limited warranty applies only to our product independently, and not to any other damage incurred due to the failure of the product.

3. Prior to using SMC products, please read and understand the warranty terms and disclaimers noted in the specified catalog for the particular products.

***2) Vacuum pads are excluded from this 1 year warranty.**

A vacuum pad is a consumable part, so it is warranted for a year after it is delivered.

Also, even within the warranty period, the wear of a product due to the use of the vacuum pad or failure due to the deterioration of rubber material are not covered by the limited warranty.

Compliance Requirements

1. The use of SMC products with production equipment for the manufacture of weapons of mass destruction(WMD) or any other weapon is strictly prohibited.

2. The exports of SMC products or technology from one country to another are governed by the relevant security laws and regulation of the countries involved in the transaction. Prior to the shipment of a SMC product to another country, assure that all local rules governing that export are known and followed.

1. Product Specific Precautions 1



Common Precautions 1

Be sure to read before handling.

Design



Warning

- All models

1. The body material is A6063, the bellows is SUS316L, and other metal seal material is SUS304. The sealing material of the vacuum part is FKM as standard, but this can be changed to other materials (refer to "How to Order"). Confirm whether the fluid to be used is compatible with the materials before use.

- With heater (thermistor)

1. When using a model with a heater, a mechanism to prevent overheating should be installed.

Selection



Caution

- High temperature type

1. If using gases that cause a large amount of deposits, heat the valve body to prevent deposits in the valve.

Mounting



Caution

- All models

1. In high humidity environments, keep the valve packed until the time of installation.
2. Perform piping so that excessive force is not applied to the flange sections. When there is vibration from heavy objects or attachments, etc., fix piping so that vibration will not apply torque directly to the flange section.
3. Vibration resistance allows for normal operation of up to 30m/s² (45 to 250Hz). Be advised that continuous vibration may cause a decline in durability. Arrange piping to avoid excessive vibration or impacts.

- High temperature type (temperature specification /H4 H5)

1. In models with a heater (thermistor), take care not to damage the insulation components of the lead wires and connector section.
2. The set temperature for models with a heater should be established without any drafts or heat insulation. It will change depending on conditions such as heat insulation measures and the heating of other piping. Fine adjustment is not possible.
3. When installing heater accessories or mounting a heater, check insulation resistance at the actual operating temperature. A current leakage breaker or fuse should be installed.
4. When a valve is to be heated, only the body section should be heated, excluding the handle section.
5. In models with a heater, when the heater is in operation, the entire valve becomes hot. Be careful not to touch it with bare hands, as burns will result.
6. The heater temperature will initially decrease several % after the heating starts and then gradually becomes stable. (The heater temperature may decrease approximately 5 to 10% due to individual differences.)

Piping

Caution

1. Before mounting, clean the surface of the flange seal and the O-ring with ethanol, etc.
2. There is an indentation of 0.1 to 0.2mm in order to protect the flange seal surface, and it should be handled so that the seal surface is not damaged in any way.

Maintenance

Warning

If the fluid or reaction product (deposit) may cause the valve to become unsafe, the valve should be disassembled, cleaned and re-assembled by an operator who has sufficient knowledge and experience (e.g. a specialist).

Caution

1. When removing deposits from the valve, take care not to damage any part of it.
2. Replace the handle assembly when the valve is approaching the end of its service life.
*For the endurance cycles, refer to Chapter 5, "Period and Scope of Warranty" (P. 9).
3. If damage is suspected prior to the end of the service life, perform early maintenance.
4. SMC specified parts should be used for service. Refer to the Construction / Maintenance parts table.
5. When removing the valve seal and external seal, take care not to damage the sealing surfaces. When installing the valve seal and external seal, be sure that the O-ring is not twisted. (Refer to Chapter 6, "Parts Replacement Procedure" (P. 10 to 11) for details.)

2. Product Specific Precautions 2



Common Precautions 2 Be sure to read before handling

Maintenance Parts



Caution

SMC specified parts should be used for service.

Refer to Chapter 5, "Construction and Dimensions" (P. 9) for the part indication numbers.

1. Replace the handle assembly when changing the sealant material. Due to the different materials used, changing only the seal may prove inadequate.

Handle assembly/construction part number (1)

Temperature specifications	Valve size			
	16	25	40	50
Standard(5~150 °C)	XLH16-30-1	XLH25-30-1	XLH40-30-1	XLH50-30-1

Note1) List the optional seal material symbol after the model number, except for the standard seal material (FKM: compound No. 1349-80). e.g.) XLH16-30-1-XN1

Exterior seal, valve seal

Description Constructions No.	Material	Valve size			
		16	25	40	50
Exterior seal (3)	Standard	AS568-025V	AS568-030V	AS568-035V	AS568-039V
	Specific	AS568-025 **	AS568-030 **	AS568-035 **	AS568-039 **
Valve seal (2)	Standard	B2401-V15V	B2401-V24V	B2401-P42V	AS568-227V
	Specific	B2401-V15 **	B2401-V24 **	B2401-P42 **	AS568-227 **

Note1) List the optional seal material symbol after the model number, except for the standard sealant material (FKM: compound no. 1349-80). e.g.) AS568-025-XN1

Note2) Refer to the Construction of each series for the construction numbers.

Note3) Due to the different materials used, changing only the seal may prove inadequate.

Additional symbols of the seal materials

Seal material	EPDM	Barrel Perfluoro®	Kalrez®	Chemraz®			VMQ	FKM for PLASMA	ULTIC ARMOR®
Combination No.	2101-80	70W	4079	SS592	SS630	SSE38	1232-70	3310-75	UA4640
Symbol	-XN1	-XP1	-XQ1	-XR1	-XR2	-XR3	-XS1	-XT1	-XU1

Note1) Due to the different materials used, changing only the seal may prove inadequate.

Barrel Perfluoro® is a registered trademark of Matsumura Oil Co.,Ltd.

Kalrez® is a registered trademark of E.I. du Pont de Nemours and Company or its affiliates.

Chemraz® is a registered trademark of Greene, Tweed Technologies, Inc.

ULTIC ARMOR® is a registered trademark of Nippon Valqia Industries, Ltd.

3. Specifications

3-1. Valve specifications

Model	XLH-16	XLH-25	XLH-40	XLH-50
Flange (valve) size	16	25	40	50
Valve type	Manual type			
Fluid	Vacuum of inert gas			
Operating temperature °C	5 to 150			
Operating pressure Pa	Atmospheric pressure to 1×10^{-6}			
Conductance l/s ^{Note 1)}	5	14	45	80
Leakage Pa·m ³ /s	Internal	1.3 x 10 ⁻¹⁰ for the standard material (FKM) at ambient temperatures , excluding gas permeation		
	External	1.3 x 10 ⁻¹¹ for the standard material (FKM) at ambient temperatures , excluding gas permeation		
Flange type	KF (NW)			
Main material	Body: aluminum alloy, Bellows: SUS316L, Main part: SUS304 and FKM (standard sealing material)			
Surface treatment for body	Outside: hard anodized Inside: basis material			
Pilot torque N·m	0.1 ≤	0.15 ≤	0.35 ≤	0.5 ≤
Handle revolutions	5	7	10	13
Weight kg	0.23	0.41	1.05	1.62

Note1) The conductance is “molecular flow” measured with an elbow pipe which has the same dimension with each flange.

3-2. Heater specifications

Item		XLH-25	XLH-40	XLH-50	
Rated voltage of the heater		90 to 240 ACV			
S y m b o l	H4	Heater assembly number	-	XLA25-60S-1	
		No. of heater assemblies	-	1 pc.	
		Initial power / Power consumption (W)	100 VAC	-	200/40
	200 VAC		-	800/40	
	H5	Heater assembly number	XLA25-60S-1	XLA25-60S-2	XLA25-60S-2
		No. of heater assemblies	1 pc.	1 pc.	1 pc.
Initial power / Power consumption (W)		100 VAC	200/40	400/70	400/80
	200 VAC	800/40	1600/80	1600/80	

Note 1) Initial power and power consumption are nominal values.

Note 2) Heaters are not available for size 16.

The heaters are PTC thermistor type design. These thermistors self regulate their temperature by switching the resistance at certain critical temperatures, so a separate temperature controller is unnecessary.

If the temperature of the PTC heaters fitted exceeds 200°C, then it may fail. The maximum operating temperature for the valve is 150°C. If the heater temperature is over 200°C or valve temperature is over 150°C, please use thermostat to control the

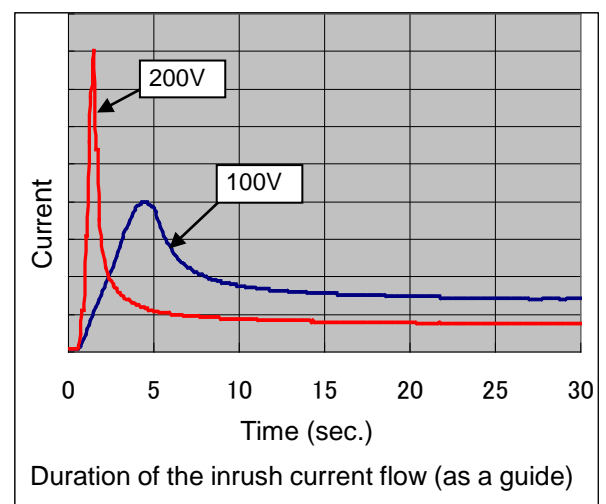

heaters to prevent overheating.

With PTC type heaters, there is an initial surge of current (inrush current) after the power is supplied. These inrush current will reduce overtime. If multiple heater assemblies are used, the inrush current to the heaters will be magnified and care should be taken. When multiple heater assemblies or valves are used, do not apply power to the heater assemblies simultaneously. Keep approximately 30 seconds between applications of power to each heater assembly. This will allow for incremental spacing to prevent harmful large initial surge.

4. Construction and Outer dimensions

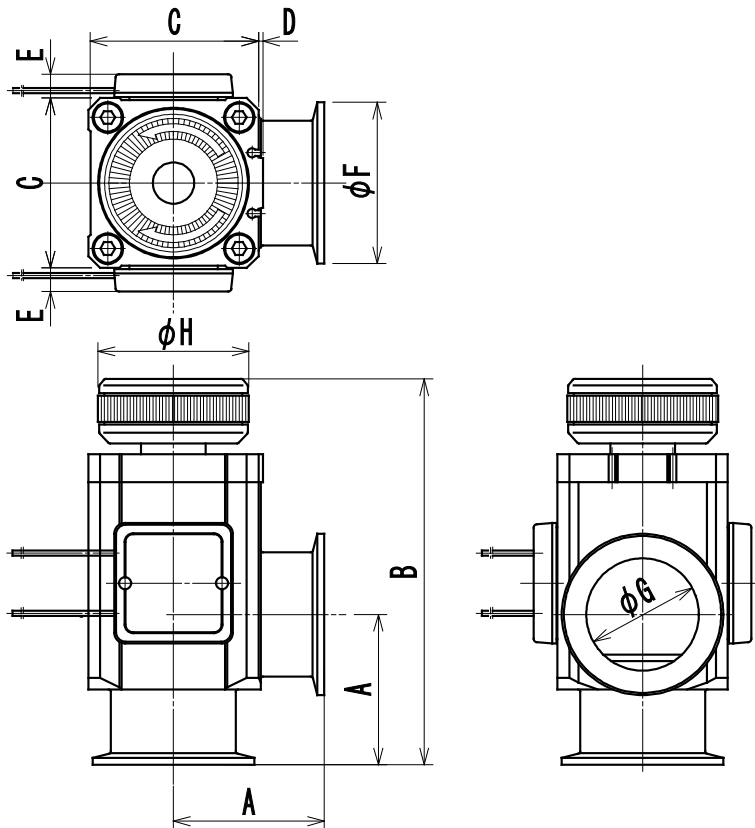
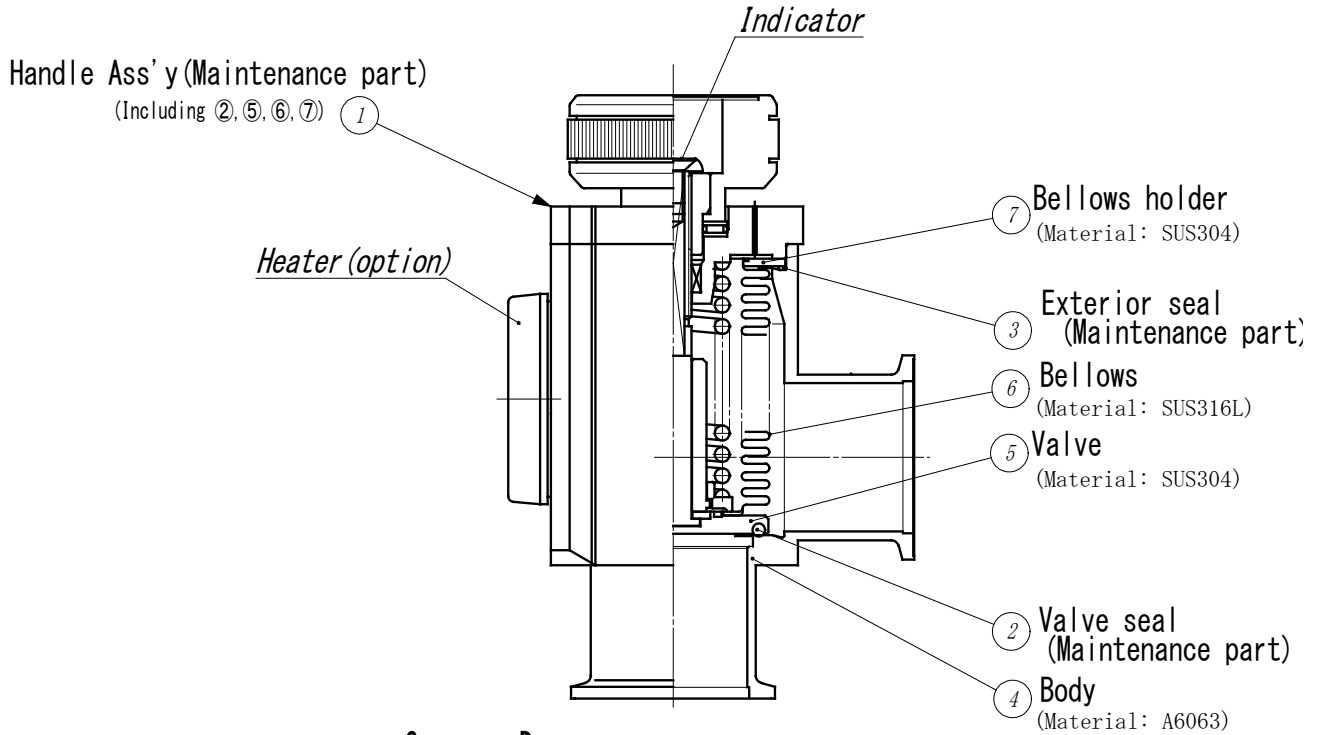

Unit: mm

Model	A	B	C	D	E	F	G	H
XLH-16	40	100.5	38	1	-	30	17	35
XLH-25	50	114	48	1	12	40	26	41
XLH-40	65	162.5	66	2	11	55	41	57
XLH-50	70	179.5	79	2	11	75	52	70

5. Period and scope of warranty

The warranty period covers the period which finishes the earliest among 0.1 million operating cycles [with our durability test conditions], 18 months after shipping from us, and 12 months after starting the use of the product at your place or your customer's place.

If the valve has been used outside of the specifications, or if a failure occurs as a result of mounting onto a machine or replacement of an assembly, O-ring etc. by the user, the warranty cannot be applied.

Notes) The endurance will depend on the operating conditions (such as if the flow rate is large).

For any failure reported within the warranty period which is clearly our responsibility, the whole valve will be replaced. This warranty does not apply to any damage incurred due to the failure of the valve.

Result of endurance test

(Using the circuit shown on the right)

The valve was opened and closed in an internal vacuum state at nominal (room) temperature and checked for internal and external leakage and proper operation.

We confirmed that the product satisfies the product specifications of 0.1 million cycles.

The test was performed with FKM, the standard sealant material.

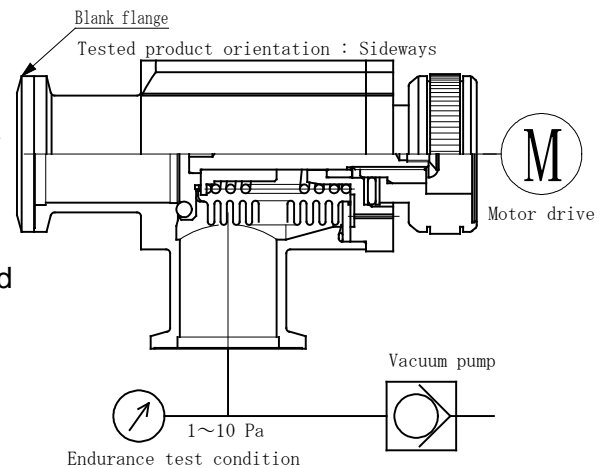

<Reference>

The pumping direction is not limited, but if the pumping creates a flow stream, the durability of the product could be impaired.

Therefore, the pumping direction shown on the right figure (bellows side pumping) is recommended.

Also, the operating conditions should be checked prior to use, as this affects the life of the product.

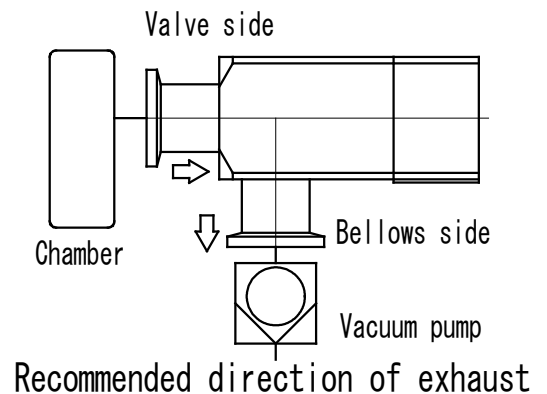

6. Parts Replacement Procedure

6-1. Precautions

Be sure to follow [1. Precautions 1] when disassembling the product for maintenance. Along with the precautions above, comply with the following precautions too.

Warning

- If it is expected that product materials may get stuck to the product, ensure safety is assured before handling. It is recommended to wear gloves and a mask.
- Pay attention to the handling of components according to the procedure in the next item onwards. Do not apply excessive force or impact. This will not only damage the product but also decrease its performance and life expectancy.
- It is not possible to disassemble the handle assembly of this product. If the components and assembly are damaged, or damage is expected, exchange the handle assembly itself.
- Do not disassemble the parts that are not explained in this operation manual. The performance and life may decrease. Also, it may cause danger.

6-2. Disassembly procedure

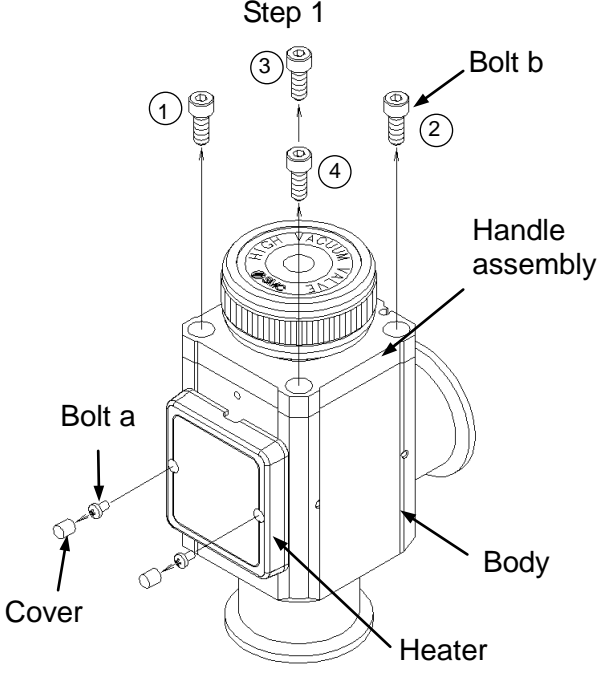
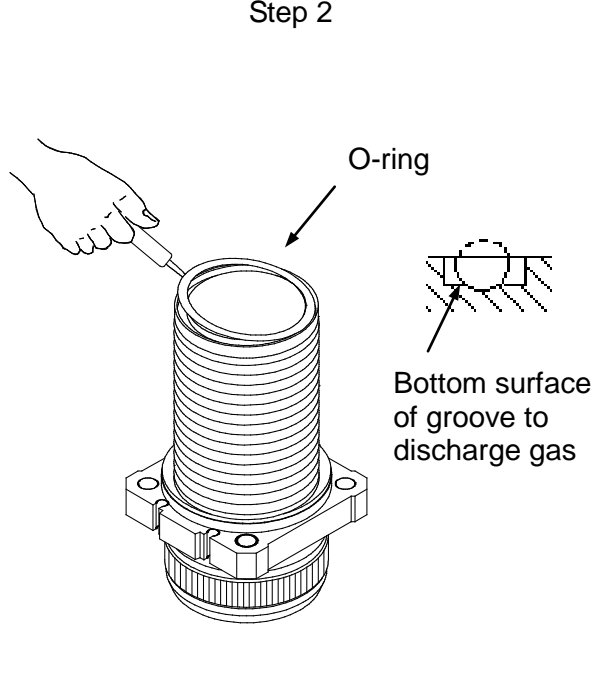
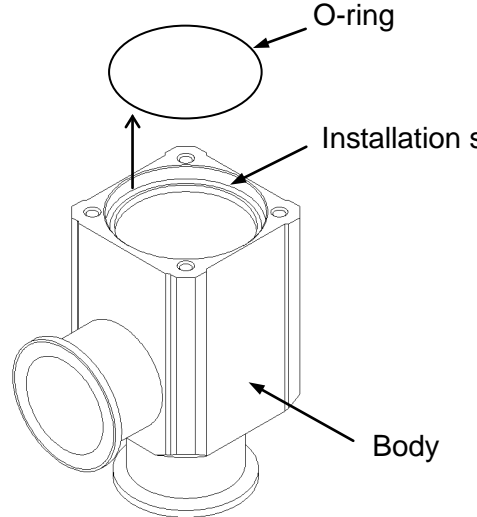
<p style="text-align: center;">Step 1</p>  <p>The heater is removed by loosening Bolt a. Bolt a is behind the Cover. Remove the Cover using a watchmaker's screwdriver. Loosen the Bolt b gradually with the valve opened a little in numerical order.</p>	<p style="text-align: center;">Step 2</p>  <p>Remove the O-ring from the groove for discharging gas using a plastic tool to prevent scratch the O-ring groove. (Take care not to scratch the O-ring groove.)</p>
<p style="text-align: center;">Step 3</p>  <p>Remove the outer seal O-ring from the Body (Take care to prevent the mounting surface of O-ring from being damaged)</p>	

6-3.Assembly Procedure

Step 1

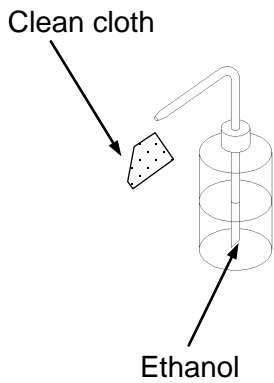

Assemble parts eliminating any dust or debris. Wipe off dust with a Clean cloth soaked with Ethanol. Blow parts with clean air if necessary. (Ensure there is no fibers or dust.)

Step 2

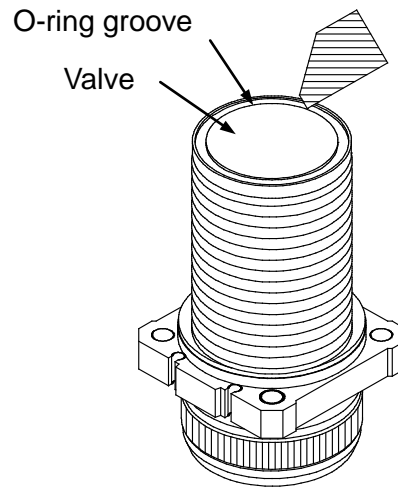

Eliminate any dust within O-ring groove of the Valve.

Step 3

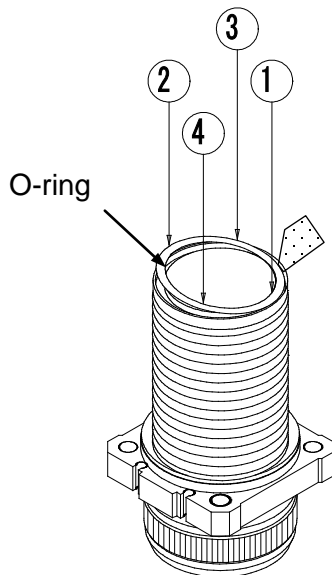

Wipe off any dust on the valve seal O-ring surface. Place the O-ring on the O-ring groove. Press the O-ring into the groove in numerical order (press diagonally) to fit the O-ring into the groove. Take care not to twist the O-ring. (Use dust-free gloves.)

Step 4

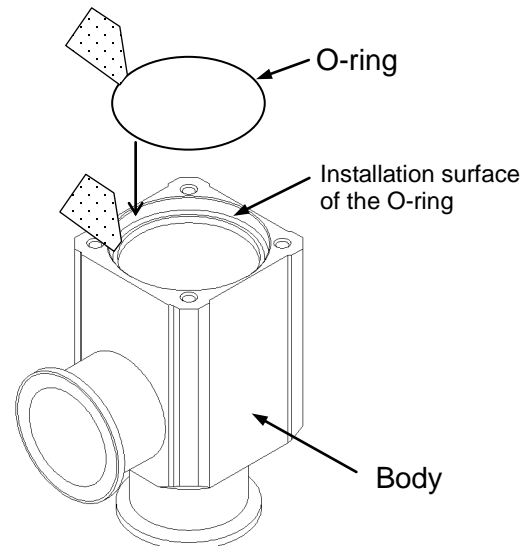

Wipe off any dust from the external O-ring seal and the mounting surface of the Body. Place the O-ring on the O-ring mounting surface.

Step 5

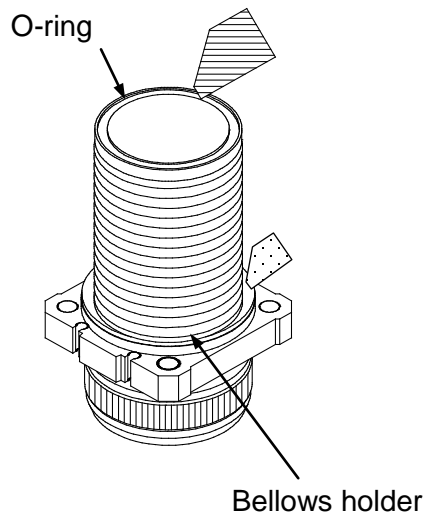

Wipe off any dust from the valve seal O-ring and the Bellows holder surface.

Step 6

Tightening torque of bolt b
N·m

Valve size	Tightening torque
XLH-16	0.7
-25	1.5
-40	2.5
-50	6

Tightening torque of bolt a
N·m

Valve size	Tightening torque
All sizes	0.3

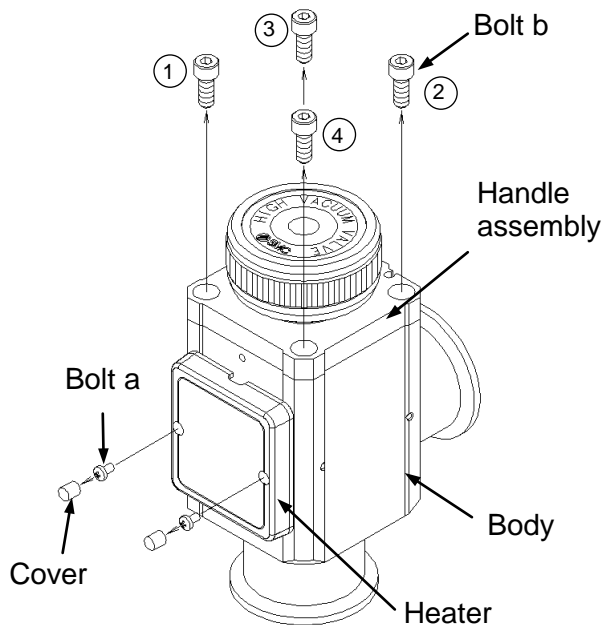

Tighten Bolt b in numerical order to assemble the Body and the Handle assembly with the valve opened a little in numerical order.

When tightening Bolt b, tighten manually until the O-ring is compressed, then perform extra tightening in diagonal order. For models with heater, tighten Bolt a to mount the Heater to the Body. Insert the Cover.

Revision	
C Renewal	2018.9

SMC Corporation

4-14-1, Sotokanda, Chiyoda-ku, Tokyo 101-0021 JAPAN

Tel: + 81 3 5207 8249 Fax: +81 3 5298 5362

URL <http://www.smcworld.com>

Note: Specifications are subject to change without prior notice and any obligation on the part of the manufacturer.
© 2011 SMC Corporation All Rights Reserved