



Operation Manual

Product name

Space Saving Vacuum Ejector Unit

Model/ Series/ Product Number

ZQ□A Series

SMC Corporation

Contents

Safety Instructions	2
1. How to Order	5
2. Summary of Product Parts	9
3. Mounting and Installation	11
3.1. Installation	11
3.2. Operating Environment	12
3.3. Air Supply	13
3.4. Piping	14
3.5. Wiring	16
4. Solenoid Valve	17
5. Vacuum Pressure Switch	18
6. Vacuum release flow adjusting needle	19
7. Structural Drawing and Replacement of Parts	20
8. Maintenance	26
9. Specifications	28
10. Pneumatic Circuit	31
11. Exhaust Characteristics, Flow Characteristics, Vacuum Pump Flow Characteristics, and Vacuum Release Flow Rate Characteristics	33
12. Handling Precautions	37
13. Trouble shooting	38



Space Saving Vacuum Ejector Unit/ZQ□A Series Safety Instructions

These safety instructions are intended to prevent hazardous situations and/or equipment damage. These instructions indicate the level of potential hazard with the labels of "Caution", "Warning" or "Danger". They are all important notes for safety and must be followed in addition to International Standards (ISO/IEC)^{*1)} and other safety regulations.

*1) ISO 4414: Pneumatic fluid power -- General rules relating to systems
 ISO 4413: Hydraulic fluid power -- General rules relating to systems
 IEC 60204-1: Safety of machinery -- Electrical equipment of machines.(Part 1: General requirements)
 ISO 10218: Manipulating industrial robots-Safety.
 etc.



Caution

CAUTION indicates a hazard with a low level of risk which, if not avoided, could result in minor or moderate injury.



Warning

WARNING indicates a hazard with a medium level of risk which, if not avoided, could result in death or serious injury.



Danger

Danger indicates a hazard with a high level of risk which, if not avoided, could result in death or serious injury.

Warning

1. The compatibility of the product is the responsibility of the person who designs the equipment or decides its specifications.

Since the product specified here is used under various operating conditions, its compatibility with specific equipment must be decided by the person who designs the equipment or decides its specifications based on necessary analysis and test results.

The expected performance and safety assurance of the equipment will be the responsibility of the person who has determined its compatibility with the product.

This person should also continuously review all specifications of the product referring to its latest catalog information, with a view to giving due consideration to any possibility of equipment failure when configuring the equipment.

2. Only personnel with appropriate training should operate machinery and equipment.

The product specified here may become unsafe if handled incorrectly.

The assembly, operation and maintenance of machines or equipment including our products must be performed by an operator who is appropriately trained and experienced.

3) Do not service or attempt to remove product and machinery/equipment until safety is confirmed.

1. The inspection and maintenance of machinery/equipment should only be performed after measures to prevent falling or runaway of the driven objects have been confirmed.

2. When the product is to be removed, confirm that the safety measures as mentioned above are implemented and the power from any appropriate source is cut, and read and understand the specific product precautions of all relevant products carefully.

3. Before machinery/equipment is restarted, take measures to prevent unexpected operation and malfunction.

4. Contact SMC beforehand and take special consideration of safety measures if the product is to be used in any of the following conditions.

1. Conditions and environments outside of the given specifications, or use outdoors or in a place exposed to direct sunlight.

2. Installation on equipment in conjunction with atomic energy, railways, air navigation, space, shipping, vehicles, military, medical treatment, combustion and recreation, or equipment in contact with food and beverages, emergency stop circuits, clutch and brake circuits in press applications, safety equipment or other applications unsuitable for the standard specifications described in the product catalog.

3. An application which could have negative effects on people, property, or animals requiring special safety analysis.

4. Use in an interlock circuit, which requires the provision of double interlock for possible failure by using a mechanical protective function, and periodical checks to confirm proper operation. Inspect the product periodically to confirm proper operation.



Space Saving Vacuum Ejector Unit/ZQ□A Series Safety Instructions

Caution

The product is provided for use in manufacturing industries.

The product herein described is basically provided for peaceful use in manufacturing industries.

If considering using the product in other industries, consult SMC beforehand and exchange specifications or a contract if necessary.

If anything is unclear, contact your nearest sales branch.

Limited Warranty and Disclaimer/ Compliance Requirements

The product used is subject to the following “Limited warranty and Disclaimer” and “Compliance Requirements”.

Read and accept them before using the product.

Limited Warranty and Disclaimer

1. The warranty period of the product is 1 year in service or 1.5 years after the product is delivered, whichever is first.*3) *

Also, the product may have specified durability, running distance or replacement parts. Please consult your nearest sales branch.

2. For any failure or damage reported within the warranty period which is clearly our responsibility, a replacement product or necessary parts will be provided.

This limited warranty applies only to our product independently, and not to any other damage incurred due to the failure of the product.

3. Prior to using SMC products, please read and understand the warranty terms and disclaimers noted in the specified catalog for the particular products.

***3) Vacuum pads are excluded from this 1 year warranty.**

A vacuum pad is a consumable part, so it is warranted for a year after it is delivered.

Also, even within the warranty period, the wear of a product due to the use of the vacuum pad or failure due to the deterioration of rubber material are not covered by the limited warranty.

Compliance Requirements

1. The use of SMC products with production equipment for the manufacture of weapons of mass destruction(WMD) or any other weapon is strictly prohibited.

2. The exports of SMC products or technology from one country to another are governed by the relevant security laws and regulation of the countries involved in the transaction. Prior to the shipment of a SMC product to another country, assure that all local rules governing that export are known and followed.











Caution

SMC products are not intended for use as instruments for legal metrology.

Measurement instruments that SMC manufactures or sells have not been qualified by type approval tests relevant to the metrology (measurement) laws of each country.

Therefore, SMC products cannot be used for business or certification ordained by the metrology (measurement) laws of each country.

■ Safety Instructions

 Warning	
 Disassembly prohibited	<ul style="list-style-type: none"> ■ Do not disassemble, modify (including the replacement of board) or repair other than instructed in this manual. Otherwise, an injury or failure can result.
 Do not	<ul style="list-style-type: none"> ■ Do not operate the product outside of the specifications. Do not use the product with flammable or harmful fluids. Fire, malfunction, or damage to the product may result. Check the specifications before use.
 Do not	<ul style="list-style-type: none"> ■ Do not use in an atmosphere containing flammable or explosive gases. Fire or an explosion may result. This product is not explosion-protected.
 Do not	<ul style="list-style-type: none"> ■ Do not use the product in a place where static electricity is a problem. Otherwise failure or malfunction of the system can result.
 Do not	<ul style="list-style-type: none"> ■ Do not cut off the power and compressed air supplied to this product while it is operating. Otherwise it can cause injury due to dropping of workpieces or damage to the system.
 Instruction	<ul style="list-style-type: none"> ■ If using the product in an interlocking circuit <ul style="list-style-type: none"> - Provide a double interlocking system, for example a mechanical system. - Check the product regularly for proper operation. Otherwise malfunction can result, causing an accident.
 Instruction	<ul style="list-style-type: none"> ■ The following instructions must be followed during maintenance <ul style="list-style-type: none"> - Turn off the power supply - Stop the air supply, exhaust the residual pressure in piping and verify that the air is released before performing maintenance work. Otherwise an injury can result.
 Do not touch	<ul style="list-style-type: none"> ■ Do not touch the terminals and connectors while the power is on. Otherwise electric shock, malfunction and damage to the product can result.
 Instruction	<ul style="list-style-type: none"> ■ Perform sufficient trial run. Otherwise, injury or damage to the system can result due to suction failure depending on the conditions of the suction of the workpiece or the pressure switch settings. Perform sufficient verification before using this product.
 Instruction	<ul style="list-style-type: none"> ■ After maintenance is complete, perform appropriate functional inspections and leak test. Stop operation if the equipment does not function properly or there is leakage of fluid. If there is leakage from parts other than the piping, the product might be broken. Cut off the power supply and stop the fluid supply. Do not supply fluid if there is leakage. Safety cannot be assured in the case of an unexpected malfunction.

1.How to Order

Vacuum Ejector System (without energy saving function)

Model of a single unit

ZQ **05** **1U** **A** **K1** **5L** **B** **E** **A** **M** **G** **-** **3** **3** **-** **N**

(1) (2) (3) (4) (5) (6) (7) (8) (9) (10) (11) (12)

(1) Nozzle nominal size

05	0.5
07	0.7
10	1.0

(2) Exhaust type

1U	With silencer for single unit
3M	With silencer for manifold

(3) Solenoid valve combination

K1	Supply valve (N.C.), Release valve (N.C)
K2	Supply valve (N.O.), Release valve (N.C)
J1	Supply valve (N.C.)
J2	Supply valve (N.O.)

(4) Electrical entry

L	L-type plug connector, with 0.3 m lead wire, with light/surge voltage suppressor
LO	L-type plug connector, without connector, with light/surge voltage suppressor

(5) Manual override

Nil	Non-locking push type
B	Slotted locking type

(6) Combination of Solenoid Valve, Pilot Valve and Power Supply Voltage ^{Note 1}

Symbol	Pressure range [kPa]	output specifications
EA	0 to -100	NPN2 output
EB		PNP2 output
EC		NPN1 output + analog voltage
EE		PNP1 output + analog voltage
FA	-100 to 100	NPN2 output
FB		PNP2 output
FC		NPN1 output + analog voltage
FE		PNP1 output + analog voltage
F ^{Note 2)}		Suction filter only

Note 1) The suction filter used in this product is a low-cost filter. When used in a dusty or dirty environment, the Filter will quickly clog. If this is the case, consider using the ZFC series or other air suction filter along with it.

Note 2) (7) and (8) do not need to be selected.

(7) Vacuum pressure switch unit specifications

Nil ^{Note 3)}	With unit selection function
M	Fixed SI unit (kPa)
P ^{Note 3)}	With unit selection function (Initial value psi)

Note 3) The unit selection function is not for use in Japan due to a new measurement law. (October 1999)

(8) Lead wire specifications

Nil	No lead wire with connector
G	Lead wire with connector (2 m, included in the package)

(9) Check valve ^{Note 4)}

Nil	None
K ^{Note 5)}	With check valve

Note 4) The check valve has the function of preventing the exhaust air from the exhaust unit from overflowing to the vacuum port side when a manifold is used. However, depending on usage conditions, it does not completely suppress air overflow.

Please thoroughly inspect the actual machine before use. Also, in order to completely prevent the overflow of exhaust air, leave plenty of space between the check valve unit and adjacent ejector to avoid interference from the ejector's exhaust unit.

Note 5) The check valve option cannot be selected when "1U" is selected for (2) and "J1" or "J2" is selected for (3).

Warning
- The check valve cannot be used for vacuum retention.
- Use a release valve.

Without a release valve, the workpiece may not be released.

(10) Fitting (V port) Note

Symbol	Applicable tubing O.D.
0	Without fitting (M5 x 0.8)
1	φ3.2 (Straight)
2	φ4 (Straight)
3	φ6 (Straight)
4	φ3.2 (Elbow)
5	φ4 (Elbow)

(11) Fitting (P port)

Symbol	Applicable tubing O.D.	Object spec.
Nil	Without port	Manifold
0	Without fitting (M5 x 0.8)	Single unit
2	φ4 (Straight)	
3	φ6 (Straight)	
5	φ4 (Elbow)	

(12) Option

Symbol	Bracket for single unit	Return spring for release valve
Nil ^{Note 6)}	Provided	None
N ^{Note 7)}	None	None
S ^{Note 8)}	None	Provided

Note 6) The bracket is not included when "3M" is selected for (2).

Note 7) This option cannot be selected when "3M" is selected for (2).

Note 8) The check valve option cannot be selected when "1U" is selected for (2) and "J1" or "J2" is selected for (3).

Also select "C" in (4) for the manifold type.

Vacuum Ejector System (with energy saving function)

Model of a single unit

ZQ **05** **1U** **A-K15LO** **B** **-VA** **M** **W** **-3** **3** **-N**

(1) (2) (3) (4) (5) (6) (7) (8) (9)

(1) Nozzle nominal size

05	0.5
07	0.7
10	1.0

(2) Body type

1U	For single unit
3M	For manifold

(3) Manual override

Nil	Non-locking push type
B	Slotted locking type

(4) Vacuum pressure switch (with suction filter ^{Note 1)})

Symbol	Pressure range [kPa]	output specifications
VA	-100 to 100	NPN1 output + Energy Saving Function
VB		PNP1 output + Energy Saving Function

Note 1) The suction filter used in this product is a low-cost filter. When used in a dusty or dirty environment, the filter will quickly clog. If this is the case, consider using the ZFC series or other air suction filter along with it.

(5) Vacuum pressure switch unit specifications

Nil ^{Note 2)}	With unit conversion function
M	Fixed SI unit (kPa)

Note 2) The unit conversion function is not for use in Japan due to a new measurement law. (October 1999)

(6) Lead wire specifications

Nil	No lead wire with connector
W	Lead wire for energy saving switch (2 m, included in the package)

(7) Fitting (V port)

Symbol	Applicable tubing O.D.
0	Without fitting (M5x0.8)
1	ø 3.2 (Straight)
2	ø 4 (Straight)
3	ø 6 (Straight)
4	ø 3.2 (Elbow)
5	ø 4 (Elbow)

(8) Fitting (P port)

Symbol	Applicable tubing O.D.	Object spec.
Nil	Without port	Manifold
0	Without fitting (M5x0.8)	Single unit
2	ø 4 (Straight)	
3	ø 6 (Straight)	
5	ø 4 (Elbow)	

(9) Option

Symbol	Bracket for single unit
Nil ^{Note 3)}	Provided
N ^{Note 4)}	None

Note 3) The bracket is not included when "3M" is selected for (2).

Note 4) This option cannot be selected when "3M" is selected for (2).

Vacuum ejector system

Manifold

ZZQ **108** **A** **-B** **S** **C** **-A**

(1) (2) (3) (4)

(1) Number of stations

01	1 stations
02	2 stations
:	:
08	8 stations

(2) Exhaust

S	With silencers (Both sides)
---	-----------------------------

(3) Vacuum release pressure supply port (PD port)

B	None (Release pressure is supplied from the P port.)
C ^{Note 1)}	Provided (Breaking pressure: Supplied from D port)

Note 1) If the standalone product does not have the energy saving function, select "S" in (12) for the individual unit.

(4) Shipping condition

Nil	Vacuum unit is assembled
A	Manifold unit only

Vacuum pump system

Model of a single unit

ZQ000 **U** **A**-**K15****L** **B**-**E****A****M** **G**-**3****3**-**N**

(1) (2) (3) (4) (5) (6) (7) (8) (9) (10)

(1) Body type

U	For single unit
M	For manifold

(2) Solenoid valve combination

K1	Supply valve (N.C.), Release valve (N.C.)
K2	Supply valve (N.O.), Release valve (N.C.)
J1 ^{Note 1)}	Supply valve (N.C.)
J2 ^{Note 1)}	Supply valve (N.O.)

Note 1) This product does not allow the adsorbing part to be released to the air at vacuum stop. Install a separate circuit for breaking vacuums.

(3) Electrical entry

L	L-type plug connector, with 0.3 m lead wire, with light/surge voltage suppressor
LO	L-type plug connector, without connector, with light/surge voltage suppressor

(4) Manual override

Nil	Non-locking push type
B	Slotted locking type

(5) Vacuum pressure switch (with suction filter ^{Note 2)})

Symbol	Pressure range [kPa]	output specifications
EA	0 to -100	NPN2 output
EB		PNP2 output
EC		NPN1 output + analog voltage
EE	-100 to 100	PNP1 output + analog voltage
FA		NPN2 output
FB		PNP2 output
FC		NPN1 output + analog voltage
FE		PNP1 output + analog voltage
F ^{Note 3)}	Suction filter only	

Note 2) The suction filter used in this product is a low-cost filter. When used in a dusty or dirty environment, the filter will quickly clog. If this is the case, consider using the ZFC series or other air suction filter along with it.

Note 3) (6) and (7) do not need to be selected.

(6) Vacuum pressure switch unit specifications

Nil ^{Note 4)}	With unit selection function
M	Fixed SI unit (kPa)
P ^{Note 4)}	With unit selection function (Initial value: psi)

Note 4) The unit selection function is not for use in Japan due to a new measurement law. (October 1999)

(7) Lead wire specifications

Nil	No lead wire with connector
G	Lead wire with connector (2 m, included in the package)

(8) Fitting (V port) Note

Symbol	Applicable tubing O.D.
0	Without fitting (M5x0.8)
1	ø 3.2 (Straight)
2	ø 4 (Straight)
3	ø 6 (Straight)
4	ø3.2 (Elbow)
5	ø 4 (Elbow)

(9) Fitting (P port)

Symbol	Applicable tubing O.D.	Object spec.
Nil	Without port	Manifold
0	Without fitting (M5x0.8)	Single unit
2	ø 4 (Straight)	
3	ø 6 (Straight)	
5	ø 4 (Elbow)	

(10) Option

Symbol	Bracket for single unit	Return spring for release valve
Nil ^{Note 5)}	Provided	None
N ^{Note 6)}	None	None
S ^{Note 7)}	None	Provided

Note 5) The bracket is not included when "M" is selected for (1).

Note 6) This option cannot be selected when "M" is selected for (1).

Note 7) The check valve option cannot be selected when "U" is selected for (1) and "J1" or "J2" is selected for (2). Also select "C" in (3) for the manifold type.

Vacuum Pump System

Manifold

ZZQ108A-SOC-A

(1) (2) (3) (4)

(1) Number of stations

01	1 stations
02	2 stations
:	:
08	8 stations

(2) Vacuum pressure supply port (PV port) Port location ^{Note 1)}

L	Left side
R	Right side

Note 1) The position of the vacuum pressure supply (PV) port when the vacuum (V) port is facing front. The pilot pressure supply (PS) port is on the opposite side.

(3) Vacuum release pressure supply port (PD port)

B	None (Release pressure is supplied from the P port.)
C ^{Note 2)}	Provided (Breaking pressure: Supplied from D port)

Note 2) Select S for the Option Symbol (10).

(4) Shipping condition

Nil	Vacuum unit is assembled
A	Manifold unit only

2. Summary of Product Parts

2.1 Summary of Product Parts

Standalone product (Vacuum ejector system)

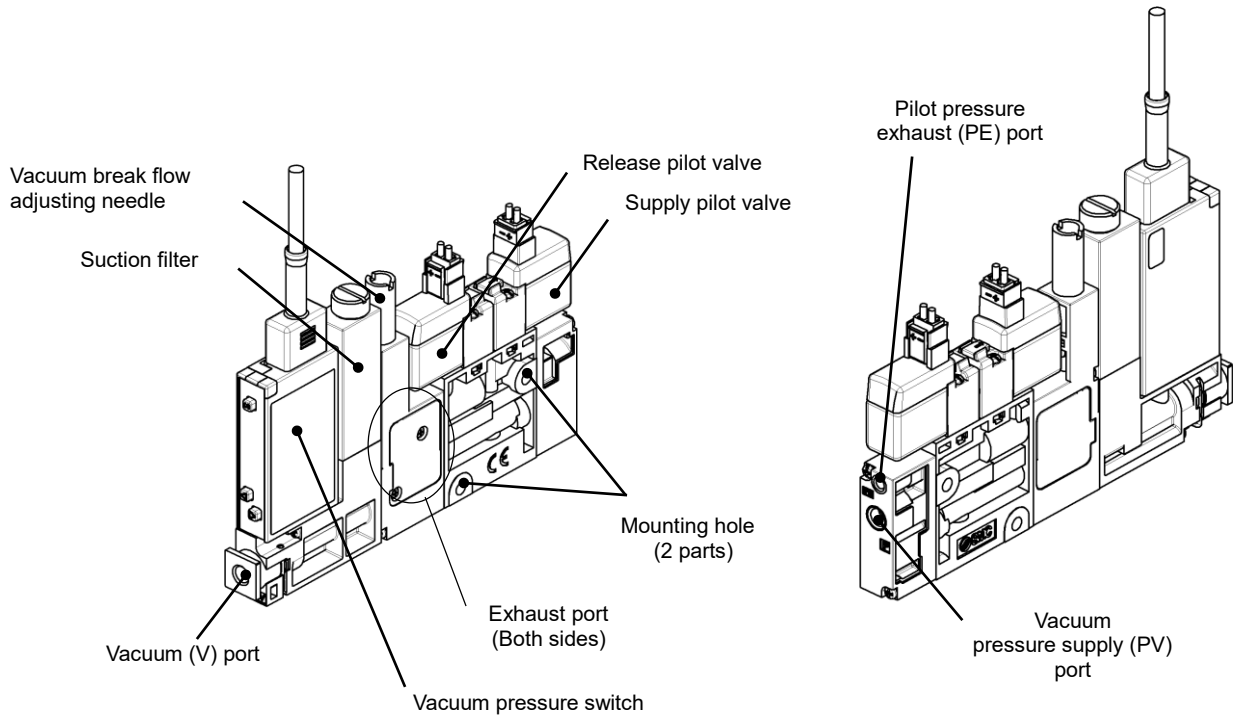

Standalone product (Vacuum pump system)

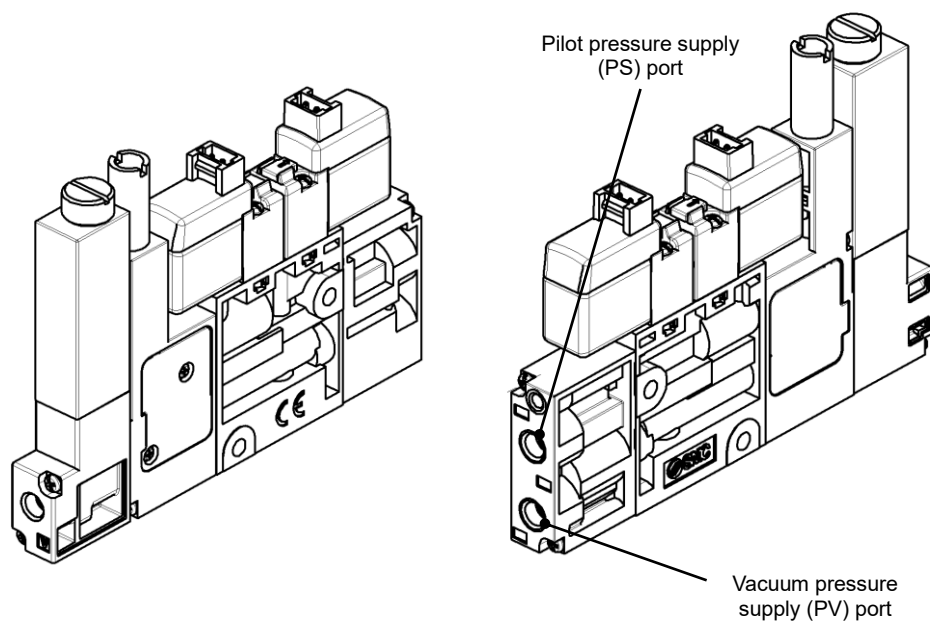

Manifold product (Vacuum ejector)

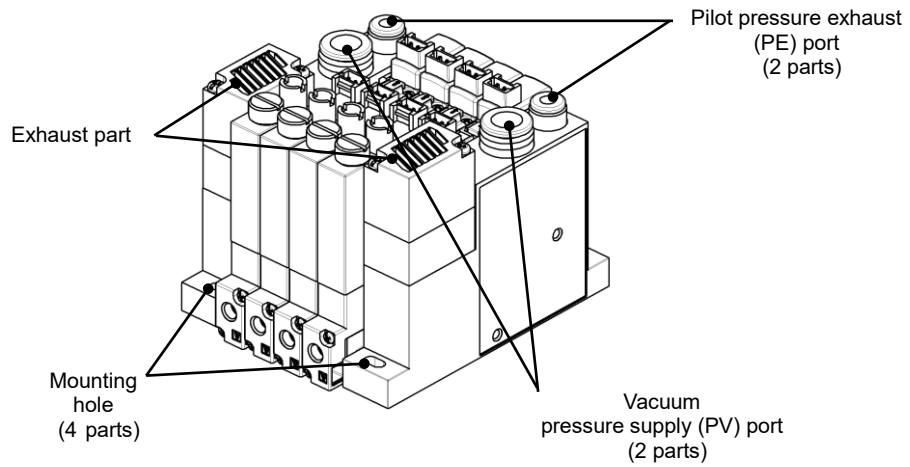

Manifold product (Vacuum pump system)

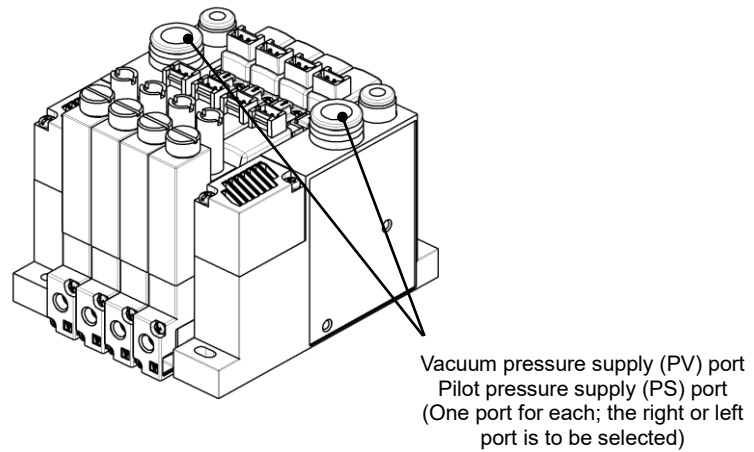

3. Mounting and Installation

3.1 Mounting

3.1.1 Standalone product (Direct mounting)

- 1) Directly mount the product on the wall surface, etc. by using the mounting holes (2 x $\phi 3.2$) in the body.
- 2) Use the recommended tightening torque (0.54 to 0.66 Nm) to mount the product.

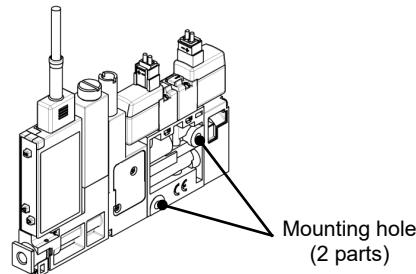

3.1.2 Standalone product (Mounting with a bracket)

- 1) Mount the optional bracket (ZQ1-BK1-A) to the mounting holes (2 x $\phi 3.2$) on the product body side using the round head combination screws and hexagon nuts included in the accessories, and mount the product on the floor, etc. using the mounting holes on the bracket (4 x $\phi 3.2$).
- 2) Use the recommended tightening torque (0.54 to 0.66 Nm) to mount the bracket.

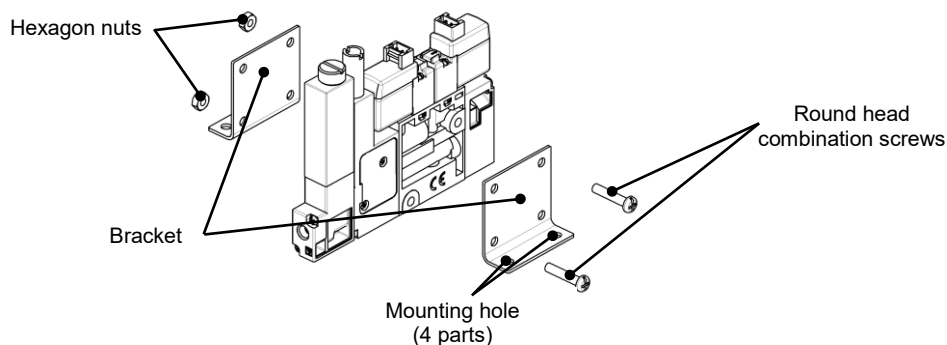

3.1.3 Manifold product

- 1) Directly mount the manifold product on the floor, etc. using the mounting holes of the end plate with the washers included in the accessories, and screws with the following recommended mounting screw size.
Recommended mounting screw size: M3 without the PD-port / M4 with the PD-port
- 2) Use the recommended tightening torque (0.54 to 0.66 Nm) to mount the product.

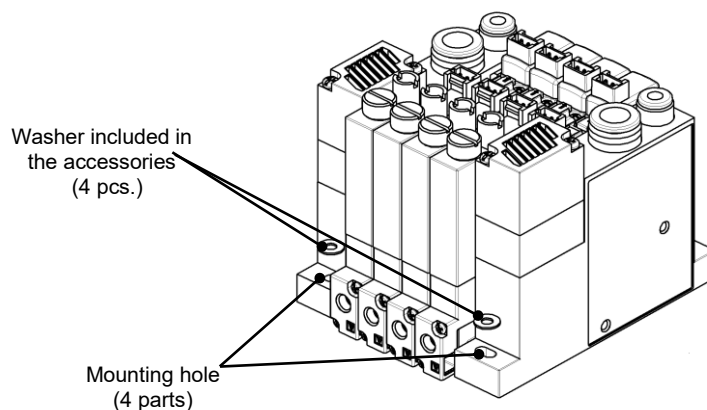

3.1.4 Precautions

- 1) When installing the product, allow sufficient space for maintenance and inspection.
- 2) Tightening torques exceeding the recommended values may damage the product and mounting screws. Insufficient torque can cause displacement of the body from its proper position as well as looseness of the mounting screws.
- 3) Do not drop, hit or apply excessive shock to the product. The exterior and internal parts, solenoid valve and pressure switch may get damaged and malfunction.

3.2 Operating environment

- 1) Do not use in an environment where corrosive gases, chemicals, sea water, water or steam are present. These can cause failure or malfunction.
- 2) Do not use the product in a place where the product could be splashed by oil or chemicals. If the product is to be used in an environment containing oils or chemicals such as coolant or cleaning solvent, even for a short time, it may be adversely affected (damage, malfunction, or hardening of the lead wires).
- 3) Do not use the product in an area where surge is generated.
When there are machines or equipment that generate large surge near the pressure switch (magnetic type lifter, high frequency inductive furnace, motor, etc.), this can result in deterioration and damage of the internal elements. Take measures against the surge sources, and prevent the lines from coming into close contact.
- 4) Do not use a load which generates surge voltage.
When a surge-generating load such as a relay or solenoid is directly driven, use the product with a surge absorbing element built-in.
- 5) Take measures against surge voltages due to lightning strikes in the system.
The product is CE marked but not immune to lightning strikes, so take measures against lightning strikes.
- 6) Be aware of excessive surrounding noise
The product is CE marked and has passed the EMC test, but excessive noises in the surrounding area may affect the functioning of the product.
- 7) Mount the product in a location that is not affected by vibration or impact.
Failure and malfunction can occur.
- 8) Do not let foreign matter, such as wire debris, get inside the product.
In order to avoid failure and malfunction, do not let foreign matter, such as wire debris, get inside the product.
- 9) Do not use this product in places where there are cyclic temperature changes.
Heat cycles other than ordinary changes in temperature can adversely affect the inside of the product.
- 10) Do not use where the product is exposed to direct sunlight.
Shade the sunlight in locations where the product is exposed to direct sunlight.
Failure and malfunction can result.
- 11) Keep within the specified operating fluid and ambient temperature range.
The operating fluid and ambient temperature range is 5 to 50°C. Operation under low temperature may lead to damage or operation failure due to frozen moisture in the fluid or air. Protection against freezing is necessary. Mounting of an air dryer is recommended for elimination of drainage and water. Avoid abrupt temperature changes even within the specified temperature range.
- 12) Do not use in a location where the product is exposed to radiant heat from surrounding heat sources. This can cause operating failure.

3.3 Air supply

3.3.1 Air quality

1) Using compressed air which contains chemicals, synthetic oils containing organic solvents, salts or corrosive gases, etc. can cause damage or malfunction. Do not use with fluid or in an environment which contains harmful impurities.

2) If the compressed air contains excessive drainage or carbon powder, it can stick to the vacuum generating part (the nozzle diffuser) or inside of the solenoid valve or the pressure switch for vacuum and cause deterioration of the performance or operation failure.

3) It is recommended to use supply air which purity class is 2:6:3 of ISO08573-1:2010 (JISB8392-1:2012). Supply air containing foreign matter, water, oil or condensate, etc. can cause malfunction of supply valve or release valve. Install an air filter or mist separator to the upper stream to prevent condensate from entering to the product and perform maintenance periodically to control the supply air properly.

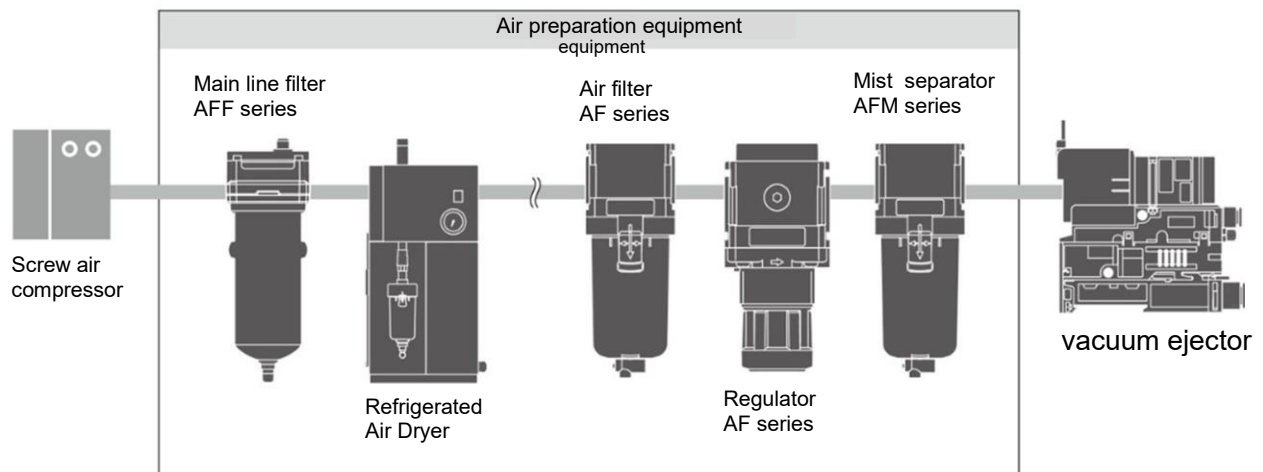

* Air quality class based on ISO8573-1:2010 (JIS B8392-1:2012)

2 : 6 : 3

● Solid particles				● Moisture		● Adhesion of oil	
Clas	Maximum particle count per m3 for particle diameter d(μm)			Clas	Pressure dew point(°C)	Clas	Oil concentration (mg/m ³)
	0.1 < d ≤ 0.5	0.5 < d ≤ 1.0	1.0 < d ≤ 5.0				
1	≤20,000	≤ 400	≤ 10	1	≤ -70	1	≤ 0.01
2	≤ 400,000	≤ 6,000	≤ 100	2	≤ -40	2	≤ 0.1
3	Not specified	≤ 90,000	≤ 1,000	3	≤ -20	3	≤ 1
4	Not specified	Not specified	≤ 10,000	4	≤ +3	4	≤ 5
5	Not specified	Not specified	≤ 100,000	5	≤ +7		
				6	≤ +10		

3.3.2 Air pressure

1) Operation with a pressure exceeding the maximum operating pressure leads to breakage of the product.

3.4 Piping

3.4.1 Port size

The port sizes and operating pressure ranges are listed below.

For the manifold type, ports are used in common for the end plate.

When supplying from one side, plug the port not in use.

Single unit type

Port	Application	Port size		Operating pressure range
		Ejector System	Pump System	
Air pressure supply (P) port	Compressed air supply for operating ejector	M5、 ϕ 4、 ϕ 6	-	0.3 to 0.5[MPa]
Air pressure supply (PV) port	Vacuum source (Vacuum pump)	-	M5、 ϕ 4、 ϕ 6	0 to -101.3[kPa]
Pilot pressure supply (PS) port	Compressed air supply for pilot pressure	-	M5、 ϕ 4、 ϕ 6	0.3 to 0.5[MPa]
Pilot pressure exhaust (PE) port	Exhaust during valve operation	M3		Released to the atmosphere
vacuum (V) port	Adsorption equipment including pad	M5、 ϕ 3.2、 ϕ 4、 ϕ 6		-

Manifold type

Port	Application	Port size		Operating pressure range
		Ejector System	Pump System	
Air pressure supply (P) port	Compressed air supply for operating ejector	ϕ 8	-	0.3 to 0.5[MPa]
Air pressure supply (PV) port	Vacuum source (Vacuum pump)	-	ϕ 8	0 to -101.3[kPa]
Pilot pressure supply (PS) port	Compressed air supply for pilot pressure	-	ϕ 8	0.3 to 0.5[MPa]
Vacuum release pressure Supply (PD) port	Compressed air supply for individual setting of release pressure	ϕ 4		0 to 0.5[MPa] ^{Note 1)}
Pilot pressure exhaust (PE) port	Exhaust during valve operation	ϕ 4		Released to the atmosphere
vacuum (V) port	Adsorption equipment including pad	M5、 ϕ 3.2、 ϕ 4、 ϕ 6		-

Note 1) The pressure must be the PS port pressure or less.

3.4.2 Piping to ports

- 1) When piping fittings, etc. are connected to the pilot pressure exhaust (PE) port (M3) for the single unit type, secure the part provided with the port, tighten it by hand, then additionally tighten by approximately one fourth of a turn using an appropriate tool. (Recommended tightening torque: 0.4 to 0.5 Nm)
- 2) When piping fittings, etc. are connected to the air pressure supply (P) port (M5) for the single unit type, secure the part provided with the port, tighten it by hand, then additionally tighten by approximately one sixth to one fourth of a turn using an appropriate tool. (Recommended tightening torque: 1.0 to 1.5 Nm)

3.4.3 Piping with one-touch fittings

■ Tube attachment

- 1) Cut the tube perpendicularly, being careful not to damage the external surface. When cutting the tube, use tube cutters. If the tube is cut by any tools other than a tube cutter, the cut surface of the tube will be slanted or flat, making it difficult to connect securely, causing the tube to come off or air leakage after the tube is connected. Also, use a tube of ample length.
- 2) Grasp the tube and push it in slowly, inserting it securely all the way into the fitting.
- 3) After inserting the tubing, pull on it gently to confirm it is secure. Incorrect insertion may cause air leakage or disconnection.
- 4) Prevent the connected tube from being rotated. The fitting may be damaged.

■ Removal of the tube

- 1) Press the release button evenly and firmly.
- 2) Pull out the tubing while keeping the release button depressed. If the release button is not held down sufficiently, the tubing cannot be withdrawn.
- 3) If the removed tubing is to be reused, cut off the section of the tubing that has been gripped. Reusing this portion of the tube can cause problems such as air leakage or difficulty in removing the tube.

■ Other manufacturer's tube

When using a brand of tube other than SMC, confirm that the following specifications are satisfied with respect to the tube outside diameter tolerance.

- | | |
|------------------------|----------------------------|
| 1) Nylon tubing | ±Within +/-0.1 mm |
| 2) Soft nylon tubing | ±Within +/-0.1 mm |
| 3) Polyurethane tubing | Within +0.15 mm or -0.2 mm |

Do not use tubing that does not meet these outside diameter tolerances. Connection to the fitting may fail, causing disconnection of the tube and air leakage.

3.4.4 Precautions for air tubes

- 1) Route tubes to prevent twisting, tension, moment loads, vibration or impact from being applied to the tubes. Failing to route correctly can cause damage to the fittings and will crush or burst tubing, or it may come out.
- 2) Piping to the product is assumed to be static piping. If the tube moves, it may wear, elongate, or tear due to tensile forces, or disconnect from the fitting. Ensure the tube is in a static condition at all times before use.
- 3) Do not lift the product by holding the tubing after piping. This may lead to damage of the filter case or One-touch fitting.
- 4) Before piping is connected, it should be thoroughly flushed with air, or washed to remove chips, cutting oil and other debris from inside the pipe. Otherwise it can cause damage or malfunction.
- 5) When connecting tubing, consider factors such as changes in the tubing length due to pressure, and leave enough slack. Failure to do so may result in fitting breakage or detachment of the tubing.
Refer to Fittings & Tubing Precautions from 1 to 4 shown in Best Pneumatics 6 on SMC's website (URL) for the recommended piping conditions.

3.5 Wiring

3.5.1 Precautions for Wiring

- 1) Do not pull the lead wire for the solenoid valve or pressure switch forcefully or lift the product by the lead wire. Otherwise damage to the solenoid valve or internal parts can result, causing malfunction or causing the connector to come out.
- 2) Avoid repeatedly bending or stretching the lead wires, or placing a heavy load or applying force to them. Repetitive bending stress or tensile stress can cause the sheath of the wire to peel off. If the lead wire can move, secure it near the body of the product. The recommended bend radius of the lead wire is 6 times the outside diameter of the sheath, or 33 times the outside diameter of the insulation material, whichever is larger. Replace the damaged lead wire with a new one.
- 3) Wire correctly. Incorrect wiring can cause malfunction or breakage of the solenoid valve or pressure switch.
- 4) Do not perform wiring while the power is on. The internal parts of the solenoid valve or pressure switch may get damaged and malfunction.
- 5) Do not route wires and cables together with power or high voltage cables. Route the wires of the product separately from power or high voltage cables in order to avoid noise or surge entering the signal line from the power or high voltage line.
- 6) Verify the insulation of wiring. Poor insulation (interference with other circuits, poor insulation between terminals etc.) can apply excessive voltage or current to the pressure switch, causing damage.
- 7) Design the product to prevent reverse current when the circuit is open or the product is forced to operate for operational checks. Depending on the circuit used, insulation may not be maintained when operation is forced, allowing reverse current to flow, which can cause malfunction and damage to the solenoid valve and pressure switch.
- 8) Keep wiring as short as possible to prevent interference from electromagnetic noise and surge voltage. Do not use a cable longer than 10m. Wire the DC (-) line as close as possible to the power supply.

4. Solenoid valve

4.1 Manual override

There are 2 types of manual override operation. Push the manual override with a screwdriver until it reaches the end. Confirm that the product operates safely before the operation of the manual override.

Manual override operation type

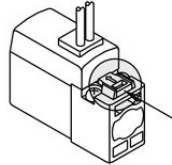

Nil: Non-locking push type

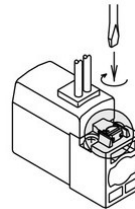

B: Slotted locking type

4.2 Wiring

To install the connector, hold the cover and insert the connector straight pushing the connector lever with your finger. Ensure that the connector lever clip is properly inserted into the groove of the cover. To remove the connector, hold the solenoid valve and pull out the connector straight pushing the connector lever clip.

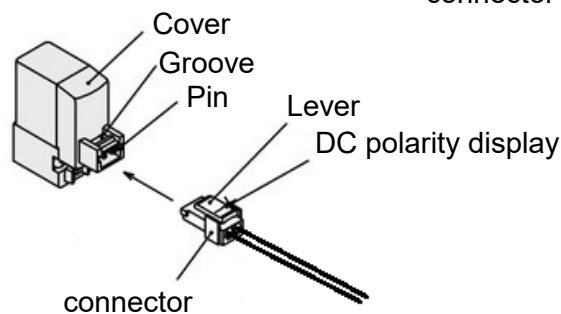

4.3 Internal circuit

With light/surge voltage suppressor A non-polar valve is installed in the product.

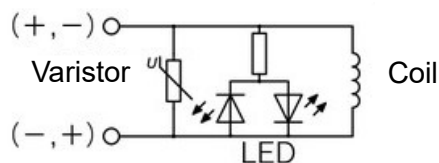

4.4 Initial state

When the valve assembly is delivered, the supply valve is on the OFF position, but it may be on the ON position due to the vibration or impact during transportation or device installation. Move supply valve to OFF position manually or energizing before use.

4.5 Precautions

- 1) The specified voltage must be used. Otherwise failure, malfunction or short life can result.
- 2) If a valve is energized for an extended period of time without a break, the rise in temperature due to heating of the coil may cause a decline in solenoid valve performance, reduce service life, or have adverse effects on peripheral equipment. The energized time in one day should be shorter than the non-energized time.
- 3) A V100 series solenoid valve is installed in the product. Refer to the Operation Manual of the V100 Series for details.

5. Vacuum pressure switch

5.1 Internal Circuit and Wiring Examples

5.2.1 Vacuum pressure switch

NPN (2 output)

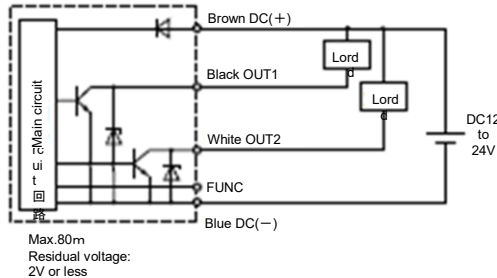

PNP (2 output)

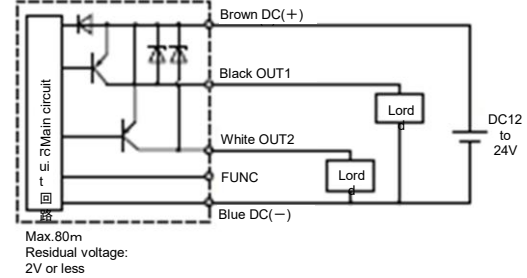

*The FUNC terminal is connected when using the copy function.

*Refer to the Operation Manual for details on setting the ZSE10 (for ZSE10 series).

5.2.2 Pressure switch for vacuum with energy saving function

NPN (1 output)

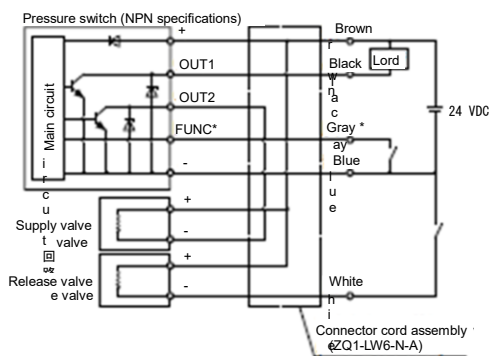

PNP (1 output)

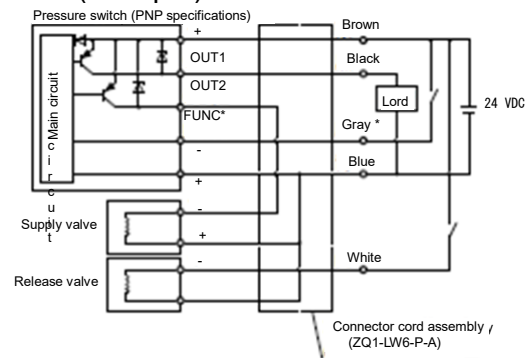

*FUNC terminal is for energy saving operation of the supply valve.

*Refer to the Operation Manual for details on setting the ZSE10 (for ZQ-ZSV series).

5.2 Handling / adjustment Precautions

- 1) The specified voltage must be used. Otherwise failure, malfunction or short life can result.
- 2) Connect a load before turning the power supply on. If the power supply is turned on with no load connected to the pressure switch, over current may occur, causing the product to break instantly.
- 3) Do not short circuit the load. An error is displayed when the load of the pressure switch is short circuited, but over current may flow, causing damage to the pressure switch.
- 4) Do not press the setting buttons with a sharp pointed object. This may damage the setting buttons.
- 5) If using the product to detect very small pressures, warm up the product for 10 to 15 minutes first. There will be a drift on the display of approximately 1% for 10 minutes after the power supply is turned on.
- 6) Perform settings suitable for the operating conditions. Incorrect setting can cause operation failure. For settings, refer to the Operation Manual of the pressure switch.
- 7) Do not touch the LED during operation. The display can vary due to static electricity.
- 8) If a commercially available switching power supply is used, be sure to ground the frame ground (FG) terminal.

6. Vacuum release flow adjusting needle

6.1 Vacuum release flow adjusting method

Vacuum release air is output by turning the release valve ON. The flow rate of vacuum release air can be adjusted by altering the vacuum release flow adjustment needle.

Loosen the lock nut and adjust the vacuum release flow adjusting needle located at the end of the lock nut using a flat blade screwdriver, etc. Rotating the vacuum release flow adjusting needle clockwise decreases the vacuum release flow while counterclockwise rotation increases it.

Tighten the lock nut after finishing the adjustment of the vacuum release flow adjusting needle to fix the adjusted position.

6.2 Precaution

- 1) Leakage cannot be completely eliminated when the needle is fully closed. A certain amount of leakage is allowed for in the product specifications. Tightening the needle to achieve zero leakage may result in equipment damage.
- 2) The vacuum release flow adjusting needle has a retaining mechanism, so it will not turn further when it reaches the rotation stop position. The needle may break if it is rotated more than 12 revolutions.
- 3) When tightening the lock nut, tighten it by approximately 15 to 30 degrees. Pay attention not to cause breakage due to over tightening.

7. Structural Drawing and Replacement of Part

7.1 Construction (single unit)

Vacuum ejector Specifications

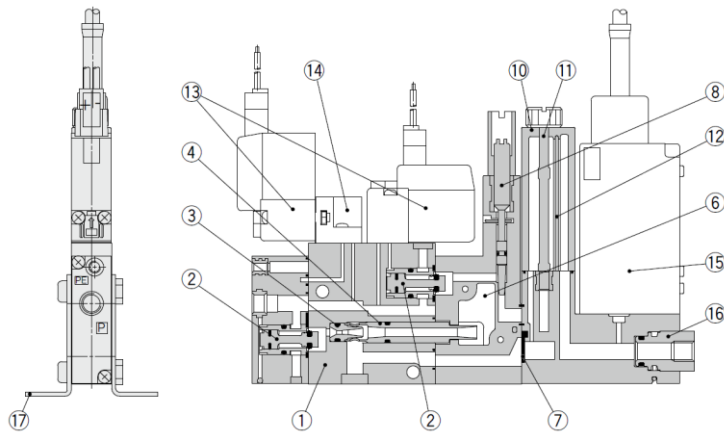

Vacuum pump system specification

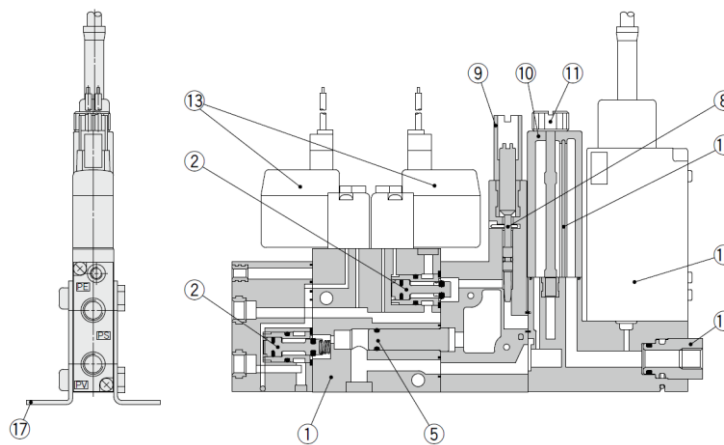

Component Parts

No.	Description	Material	Note
1	Body	PBT	Brass and aluminum alloy are used in addition to resin
2	supply valve, release valve assembly	POM, Aluminum alloy	
3	Nozzle	PBT	
4	Diffuser	PBT	
5	Bushing	Aluminum alloy	
6	Sound absorbing material	Non-woven fabric (PET)	Refer to Replacement Part 3 .
7	Check valve	HNBR	Refer to Replacement Part 6 .
8	Vacuum break flow adjusting needle	SUS	
9	Lock nut	Aluminum alloy (Anodized)	
10	Filter vessel	PC	Refer to Replacement Part 4 .
11	Tension bolt	SUS	
12	Filter element	PVA sponge	Refer to Replacement Part 5 .
13	Pilot valve for supply/ release	-	Refer to Replacement Part 1 .
14	Adapter plate	PBT	
15	Vacuum pressure switch	-	Refer to Replacement Part 2 .
16	Vacuum (V) port adapter	-	Refer to Replacement Part 7 .
17	Bracket assembly	Steel (nickel plated, zinc chromate)	Refer to Replacement Part 8 .
-	Sealing material (O-ring, etc.)	HNBR, NBR	
-	Assembly screws	Steel (nickel plated, zinc chromate)	

7.2 Manifold exploded view

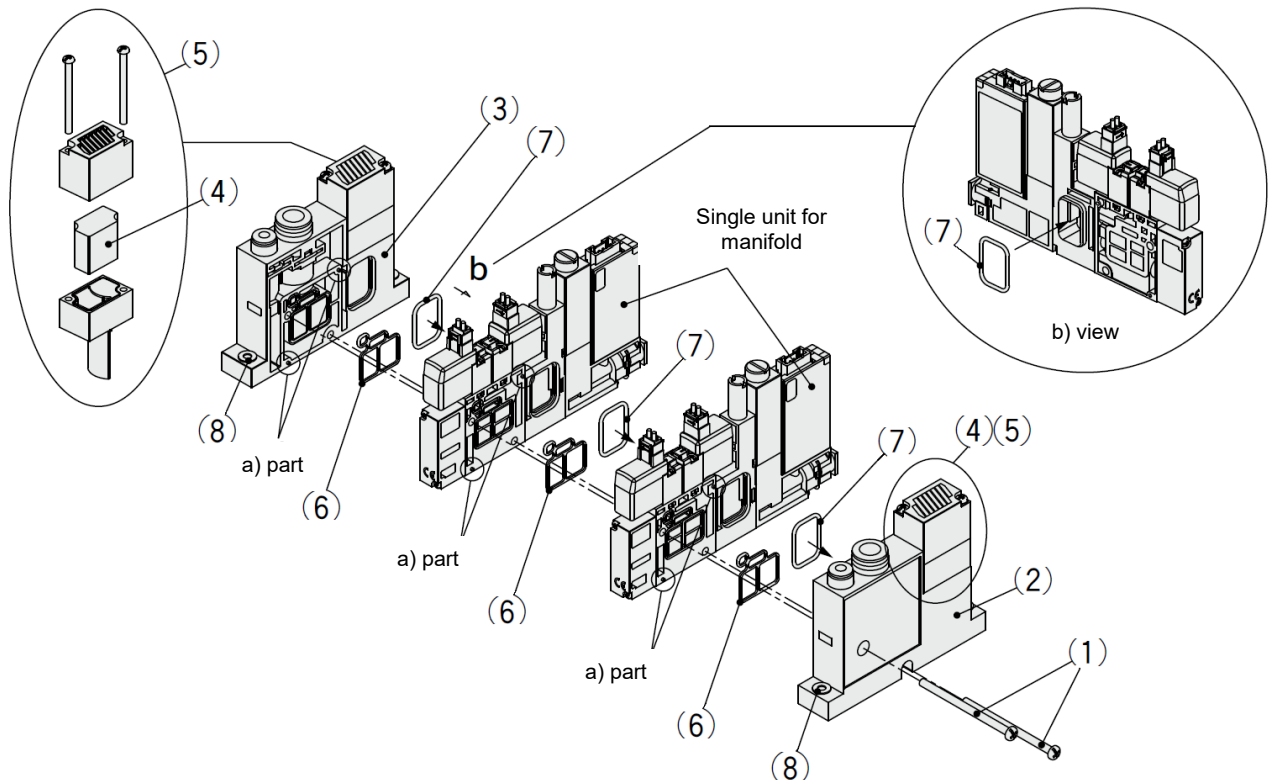

Procedure for increasing and decreasing the number of manifold stations

Disassembly

1. (1) Remove the clamping rods (2 pcs.).
2. (2) Remove end block L (Be careful not to drop the gasket).

Assembly

1. Confirm that the ejector body gasket for manifold (7) is mounted to the gasket groove of each single unit, and that the exhaust block gasket (8) is mounted to the outer side of the raised part (viewed from b).
2. Confirm that the ejector body gasket for manifold (7) is mounted to the gasket groove for end block R (3).
3. Confirm that the exhaust block gasket is mounted to the outer side of the raised part of end block L (2).
4. Put together the single units for manifold, end block R (3), and end block L (2) using the positioning pins (a, two locations), and assemble them using the clamping rods (1).
(Recommended tightening torque: 0.54 to 0.66 Nm)

Component Parts

No.	Description	Material	Note
1	Clamping rod assembly	Steel (zinc chromate)	Refer to Replacement Part 9.
2	End block L	POM, POM, PET, steel, aluminum alloy, brass, SUS	Left side with the vacuum port facing the front.
3	End block R	POM, POM, PET, steel, aluminum alloy, brass, SUS	Right side with the vacuum port facing the front.
4	Sound absorbing material	Non-woven fabric (PET)	Refer to Replacement Part 10.
5	Silencer block assembly	PBT	Refer to Replacement Part 11.
6	Ejector body gasket for manifold	NBR	Refer to Replacement Part 12.
7	Exhaust block gasket	NBR	Refer to Replacement Part 13.
8	Washer assembly	Steel (zinc chromate)	Refer to Replacement Part 14.

7.3 How to Order Replacement Parts

1 Pilot valve for supply/ release

Pilot valve for N.C. supply/ release

Z1-V114-5LUB-A
(1) (2)

A

(1) Electrical entry

L	L-type plug connector, with 0.3 m lead wire
LO	L-type plug connector, without connector

(2) Manual

Nil	Non-locking push type
B	Slotted locking type

N.O. supply pilot valve (including adapter plate)

ZQ1-V124-5MUB-A
(1) (2)

(1) Electrical entry

M	L-type plug connector, with 0.3 m lead wire
MO	M-type plug connector, without connector

(2) Manual

Nil	Non-locking push type
B	Slotted locking type

Lead wire with connector for solenoid valve assembly

SY100-30-4A-
(1)

(1) Lead wire length

Nil	300mm
6	600mm
10	1000mm
15	1500mm
20	2000mm
25	2500mm
30	3000mm
50	5000mm

A

Solenoid valve connector, socket

SY100-30-A

* Connector and socket (2 pcs.) only

2 Vacuum pressure switch (with suction filter)

ZQ-ZSEAMGK-2-A

(1) (2) (3) (4) (5)

(1) Vacuum pressure switch specifications

Symbol	Pressure range [kPa]	Output specifications
EA	0 to -100	NPN2 output
EB		PNP2 output
EC		NPN1 output + analog voltage
EE		PNP1 output + analog voltage
FA	-100 to 100	NPN2 output
FB		PNP2 output
FC		NPN1 output + analog voltage
FE		PNP1 output + analog voltage
VA ^{Note 1)}		NPN1 output + energy saving function
VB ^{Note 1)}		PNP1 output + energy saving function

Note 1) It is not possible to replace the vacuum pressure switch from the specification without energy saving function to the specification with energy saving function.

(2) Unit

Nil ^{Note 2)}	With unit selection function
M	Fixed SI unit (kPa)
P ^{Note 2) , Note 3)}	With unit selection function (Initial value psi)

Note 2) The unit selection function is not for use in Japan due to a new measurement law. (October 1999)

Note 3) Not possible to select when (1) is VA or VB

(3) Lead wire specifications

Nil	No lead wire with connector
G	Lead wire with connector (Lead wire length 2 m)
W	Lead wire for energy saving switch (2m)

(4) Check valve^{Note 4)}

Nil	None
K ^{Note 5)}	With check valve

Note 4) The check valve has a function to prevent the exhaust air from the silencer overflowing to the vacuum port side when a manifold is used, but it cannot prevent overflow of the exhaust air completely. During usage, please inspect thoroughly with actual machine.

Note 5) When VA or VB is specified for (1), the check valve is already built in.

(5) Fitting (V port)

0	Without fitting (M5x0.8)
1	∅ 3.2 (Straight)
2	∅ 4 (Straight)
3	∅ 6 (Straight)
4	∅ 3.2 (Elbow)
5	∅ 4 (Elbow)

Lead wire with connector for vacuum pressure switch

Lead wire with connector for vacuum pressure switch

ZS-39-5G

Lead wire with connector for energy saving Pressure switch

ZQ1-LW6-N-A
(1)

(1) Output

N	NPN open collector
P	PNP open collector

3 Silencer plate assembly**ZQ1-PL11-A**4 Filter vessel assembly**ZQ1-FC1-A**5 Filter element (10 pcs. are included in one set)**ZQ1-FE2-A**6 Check valve**ZQ1-CV**7 V port fitting**VVQ1000-50A-C4**
(1)Clip (10 pcs. are included in one set)**ZK1-CP-A**

(1) Specifications

50A-M5	Without fitting (M5x0.8)
50A-C3	ø 3.2 (Straight)
50A-C4	ø 4 (Straight)
50A-C6	ø 6 (Straight)
F1-LC3	ø 3.2(Elbow)
F1-LC4	ø 4 (Elbow)

A
A8 Bracket assembly**ZQ1-BK1-A**

9 Clamping rod assembly (2 pcs. are included in one set)

ZQ1-SR1-04-A

(1)

(1) Number of stations

01	1 stations
02	2 stations
:	:
08	8 stations

10 Sound absorbing material (for manifold) (2 pcs. are included in one set)

ZQ1-SE2-A

11 Silencer block assembly (2 pcs. are included in one set)

ZQ1-SC1-A

12 Ejector body gasket for manifold (10 pcs. are included in one set)

ZQ-3-005-10AS

13 Exhaust block gasket (10 pcs. are included in one set)

ZQ-3-009-10AS

14 Washer assembly (4 pcs. are included in one set)

ZQ1-WS3-A

(1)

(1) Size

3	M3 (without release pressure supply port)
4	M4 (with release pressure supply port)

A

A

8. Maintenance

Perform the following checks and maintenance in order to use the vacuum unit safely and in an appropriate way.

8.1 How to replace the Silencer

Single unit type

- 1) Loosen the mounting screws (2 pcs) of the silencer plates to remove the silencer plates (2 pcs.) and the sound absorbing material.
- 2) Replace the silencer plates (2 pcs.) and the sound absorbing material.
- 3) Assemble the silencer plates with the mounting screws. (Recommended tightening torque: 0.028 to 0.032 Nm)

* Resin tapping screws are used to assemble the silencer plates.

When replacing the sound absorbing material, replace the silencer plates at the same time. Using a higher torque than necessary for assembly may damage the screw part.

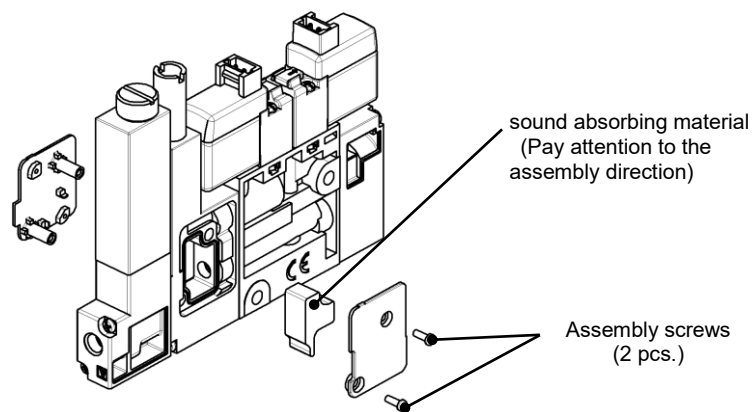

Manifold type

- 1) Loosen the mounting screws (2 pcs.) of the silencer block to remove it.
- 2) Replace the sound absorbing material in the silencer block.
- 3) Assemble the silencer block with the mounting screws. (Recommended tightening torque: 0.25 to 0.31 Nm)

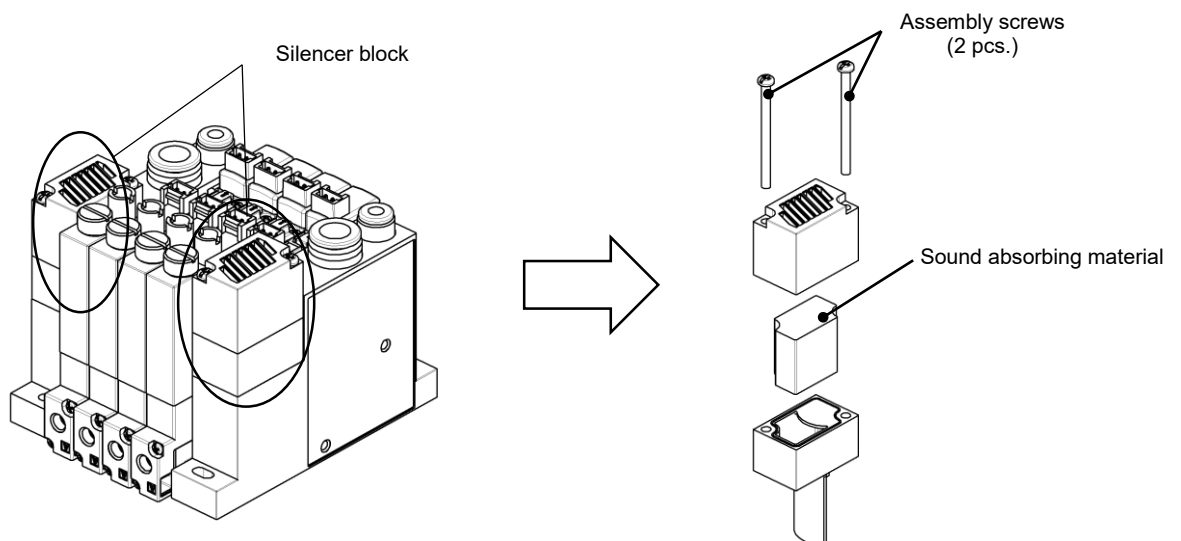

8.2 How to replace the filter element

- 1) Loosen the tension bolt and remove the filter case.
 - 2) Replace the filter element in the filter case.
 - 3) Assemble the filter case with the tension bolt.
- (Recommended tightening torque: 0.12 to 0.18 Nm)

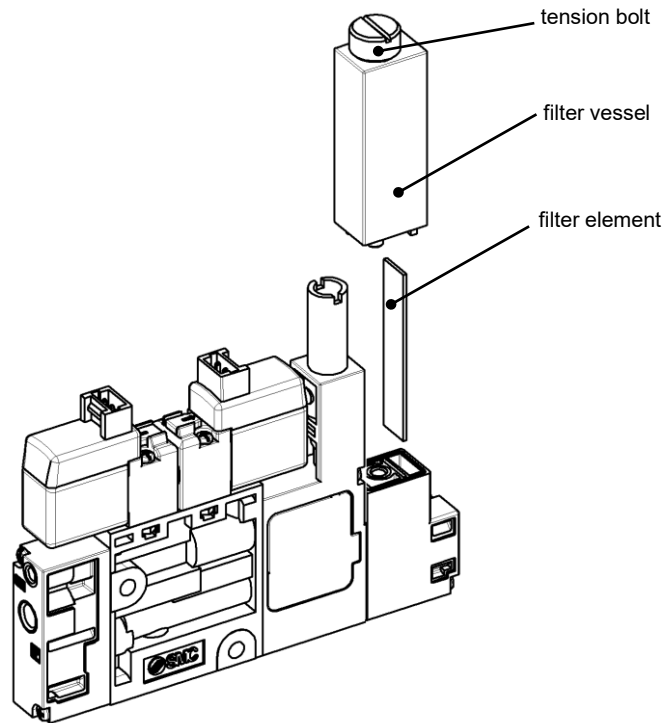

8.3 How to replace the solenoid valve

A

- 1) Loosen the mounting screws (2pcs.) of the solenoid valve to remove it.
 - 2) Replace the solenoid valve and assemble it using the mounting screws (2 pcs.).
- (Recommended tightening torque: 0.054 to 0.080Nm)

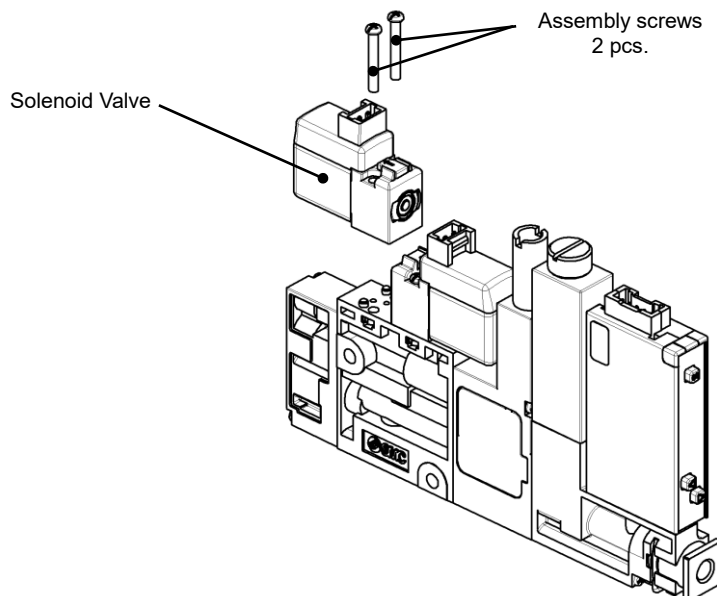

8.4 How to replace the vacuum pressure switch

A

- 1) Remove the V port fitting fixing clip, loosen the mounting screws (2pcs.) of the vacuum pressure switch, and then remove the vacuum pressure switch.
- 2) Replace the vacuum pressure switch and assemble it by using the mounting screws (2pcs.).
(Recommended tightening torque: 0.11 to 0.13Nm)
- 3) Assemble the V port fitting fixing clip.

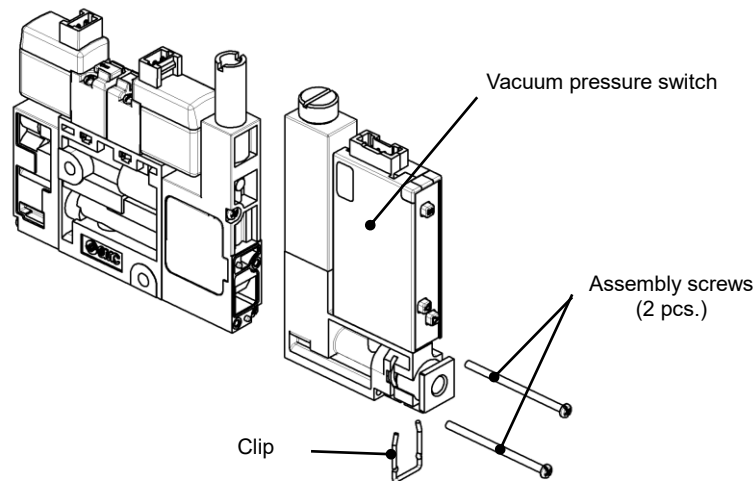

8.5 How to replace the check valve

A

- 1) Remove the pressure switch and filter assembly as described in "8.4 How to replace the vacuum pressure switch" (There is no one-touch fitting fixing clip for the filter assembly.).
- 2) Replace the check valve that is built into the pressure switch or filter assembly.
- 3) Assemble the pressure switch and filter assembly as described in "8.4 How to replace the vacuum pressure switch".

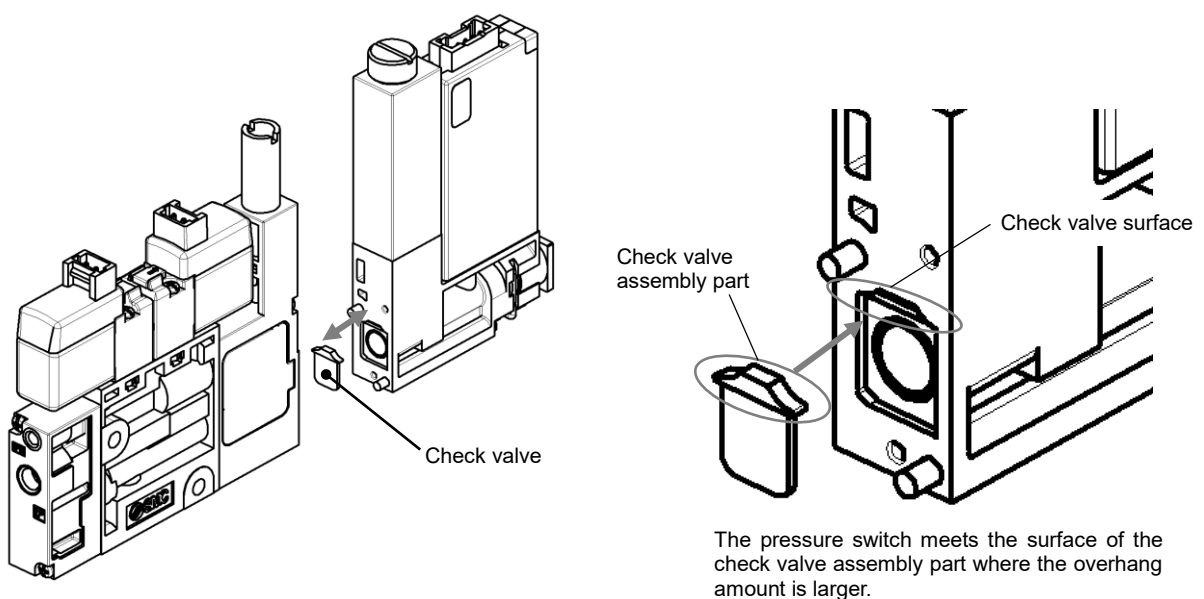

8.6 Actuators / Precautions

- 1) Maintenance should be performed according to the procedure indicated in the Operation Manual. Incorrect handling can cause damage of equipment and device, and operation failure.
- 2) During maintenance, compressed air can be dangerous when handled incorrectly. The assembly, handling, repair and element replacement of pneumatic systems should be performed by a knowledgeable and experienced person.
- 3) Remove drainage from air filters and mist separator regularly. If the collected drainage is drained to the downstream side, it can stick inside of the product, causing operation failure and failure to reach the specified vacuum pressure. If the drain bowl is difficult to check and remove, the installation of a drain bowl with an auto drain option is recommended.
- 4) Replace the filter element in the ejector regularly. It is recommended to replace the filter element when the pressure drop reaches 5 kPa as a guideline. The replacement cycle varies depending on the operating conditions, operating environment, and supply air quality. However, if there is a vacuum pressure drop and/or delay in the vacuum (adsorption) response time which causes problems with the settings during operation, stop the operation of the product and replace the filter element regardless of the above mentioned replacement guideline.
- 5) When the product is to be removed, turn off the power supply, and be sure to cut off the supply pressure and exhaust the compressed air. Confirm that the air is released to atmosphere. When mounting the product after the maintenance work, supply compressed air, connect to the power, check if it functions properly and check for leaks.
- 6) Do not disassemble or modify the product, other than the replacement parts specified in this manual.
- 7) Do not use solvents such as benzene, thinner etc. to clean the product. These can damage the surface of the body and erase the markings on the body. Use a soft cloth to remove stains. For heavy stains, use a damp cloth that has been soaked with diluted neutral detergent and fully squeezed, then wipe up the stains again with a dry cloth.

9. Specifications

9.1 Product specifications

General Specifications

Item	ZQ□A series
Operating temperature range [°C]	5 to 50 (No condensation)
Fluid	Air
Vibration resistance [m/s^2] ^{Note 1)}	20
Impact resistance [m/s^2] ^{Note 2)}	100
Standards	CE marking, RoHS

Note 1) 10 to 150 Hz., 2 hours in the directions of X, Y, and Z respectively (not energized, initial value)

Note 2) 3 times in the directions of X, Y, and Z respectively (not energized, initial value)

Vacuum ejector system specifications

Item		ZQ05□A	ZQ07□A	ZQ10□A
Nozzle diameter [mm]		0.5	0.7	1.0
Standard supply pressure [MPa]		0.35	0.43	
Max. vacuum pressure [kPa] ^{Note 1)}		-80		
Max.suction flow[L/min (ANR)] ^{Note 1)}		5	10	22
Air consumption [L/min (ANR)] ^{Note 1)}		15	25	47
Supply pressure range [MPa]	Vacuum pressure supply (PV) port	0.3 to 0.5		
	Release pressure supply port (PD port) ^{Note 2)}	0 to 0.5		
Maximum supply pressure [MPa]		0.75		
Number of Manifold Stations that Can Operate Simultaneously		8	6	4
Noise Level [dB (A)] ^{Note 3)}	Single unit	65	68	70
	Manifold (Maximum number of Stations that can be connected simultaneously)	64	66	68

Note 1) Values are based on SMC measurement standards. They depend on atmospheric pressure (weather, altitude) and measurement method.

Note 2) The pressure must be the P port pressure or less.

Note 3) Actual values under SMC's measurement conditions (Not guaranteed values)

Vacuum pump system specification

Item		ZQ000A
Flow characteristics V → PV (vacuum side)	C[dm ³ / (s · bar)]	0.31
	B	0.23
	Cv	0.09
Flow characteristics PD → V (release side) ^{Note 1)}	C[dm ³ / (s · bar)]	0.24
	B	0.26
	Cv	0.08
Operating pressure range [MPa] ^{Note 2)}	Vacuum pressure supply (PV) port [kPa]	0 to -101.3
	Pilot pressure supply (PS) port [MPa]	0.3 to 0.5
	Release pressure supply port (PD port) [MPa]	0 to 0.5

Note 1) When the vacuum release flow adjusting needle is fully open.

Note 2) The pressure must be the P port pressure or less.

9.2 Weight

Single part number

Model, additional specifications	Weight [g]
ZQ□□UA-K15L-F-00-N (Basic type for single unit)	70
ZQ□□MA-K15L-F-0 (Basic type for manifold)	70
Without release valve	-10
Supply valve N.O. specification	+2
With vacuum pressure switch (Lead wire is not included)	+20
Bracket assembly type	+25
Lead wire with connector for vacuum pressure switch	+45
Lead wire with connector for energy saving vacuum switch	+50

Manifold part number

Model, additional specifications	Weight [g]
ZZQ101-BSB	115
ZZQ101-BSC	130
ZZQ101-□OB	105
ZZQ101-□OC	120
1 station	+2

Calculation Formula for Weight of the Manifold Type

(Weight of the single unit x Number of stations) + (Weight of the manifold part number) +
(Weight of 1 station x Number of stations)

9.3 Supply/release pilot valve specifications

Model	Normally closed	Normally open
Model	Z1-V114-5LU	ZQ1-V124-5MU-A
Manual override	Non-locking push type / Slotted locking type	
Rated coil voltage	24 VDC	
Allowable voltage range	-10 to 10 (%)	
Electrical entry	L plug connector (with light/surge voltage suppressor)	M plug connector (with light/surge voltage suppressor)
Electrical entry	Cross section : 0.2 to 0.33mm ² , Max. O.D. of sheath 1.7mm	

Note) For details on the V100 series, refer to the Operation Manual for that series.

9.4 Vacuum Switch Specification

Product Number		ZSE10				
		Vacuum pressure switch	Pressure switch for compound pressure	Pressure switch for vacuum with energy saving function		
Rated pressure range [kPa]		0 to -101	-100 to 100			
Set / display pressure range [kPa]		10 to -101	-105 to 105			
Proof pressure [kPa]		500				
Lowest configurable increment [kPa]		0.1				
Applicable fluid		Air, non-corrosive gas and non flammable gas				
Power supply voltage: [DCV]		12 to 24 \pm 10%, ripple (p p), 10% or less (with reverse connection protection)				
Current consumption [mA]		40 or less				
Switch output		NPN or PNP open collector 2 outputs (selectable)		NPN or PNP open collector OUT1 General purpose, OUT2 Valve control		
		Maximum load current [mA]		80		
		Maximum applied voltage [V]		28 (NPN output)	26.4 (NPN output)	
		Maximum applied voltage [V]		2 or less (with load current of 80)		
		Response time [ms]		2.5 or less (Response time selections with anti-chattering function: 20, 100, 500, 1000 and 2000)		
Short circuit protection		With short-circuit protection				
Repeatability		\pm 0.2 (%) F.S. \pm 1digit				
Hysteresis		Hysteresis mode				
		Adjustable (can be set from 0) ^{*1}				
Voltage output		Window comparator mode		Adjustable (can be set from 0) ^{*1}		
		Voltage output		Output voltage (rated pressure range)	1 to 5V \pm 2.5 (%) F.S.	
				Linearity	+/-1 (%) F.S.	
		Output impedance	Approx. 1 k Ω			
Display method		3 1/2-digit, 7 segment LED 1-color display (Red)				
Display accuracy		+/-2 (%) F.S. \pm 1digit (ambient temp. 25+/-3 °C)				
Operation indicator		Turns ON when the switch is ON (OUT1: Green, OUT2: Red)				
Environmental resistance		Enclosure rating				
		IP 40				
		Operating temperature range [°C]		During operation : -5 to 50 (no freezing, no condensation) Storage : -10 to 60		
		Operating humidity range [%RH]		Operation, storage: 35 to 85 °C (no condensation or freezing)		
Withstand voltage [ACV]		1000V AC for 1 minute between terminals and housing				
Insulation resistance (M Ω) [M Ω]		50 or more between terminals and housing (with 500V DC megger)				
Temperature characteristics		+/-2 (%) F.S. (at 25°C of ambient temperature range between -5 and 50°C)				
Lead wire		Oil-resistant cabtire cord Cross section: 0.15 mm ² (AWG26), 5 cores, Conductor O.D.: 1.0 mm				
Standards		CE marking (EMC directive, RoHS directive)				

Note 1) If the applied pressure fluctuates around the set value, the hysteresis must be set to a value more than the amount of fluctuation or chattering will occur.

1 0 . Pneumatic Circuit

Vacuum ejector Single unit type
 ZQ□1UA-□5L□-□□□-□□

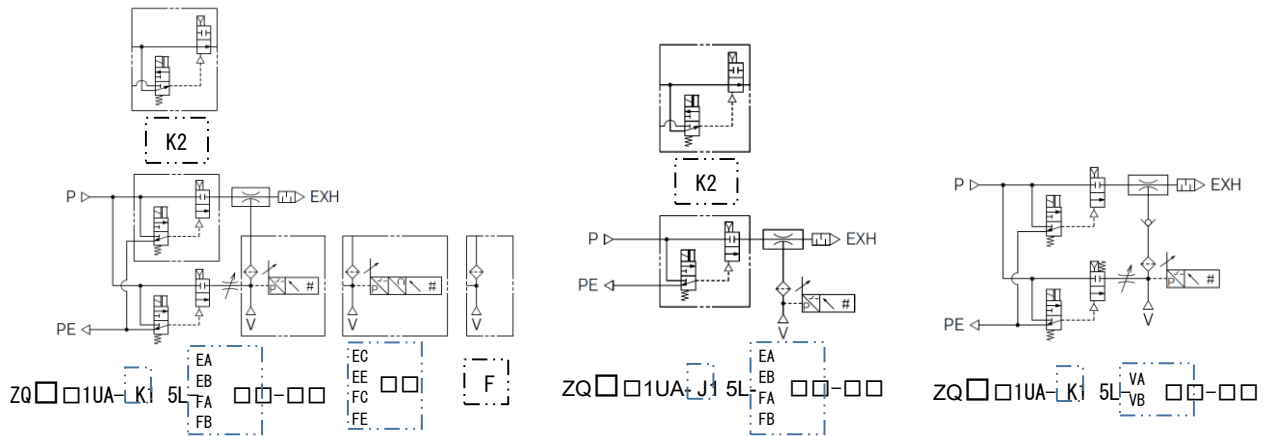

Vacuum pump system Single unit type
 ZQ000UA-□5L□-□□□-□□

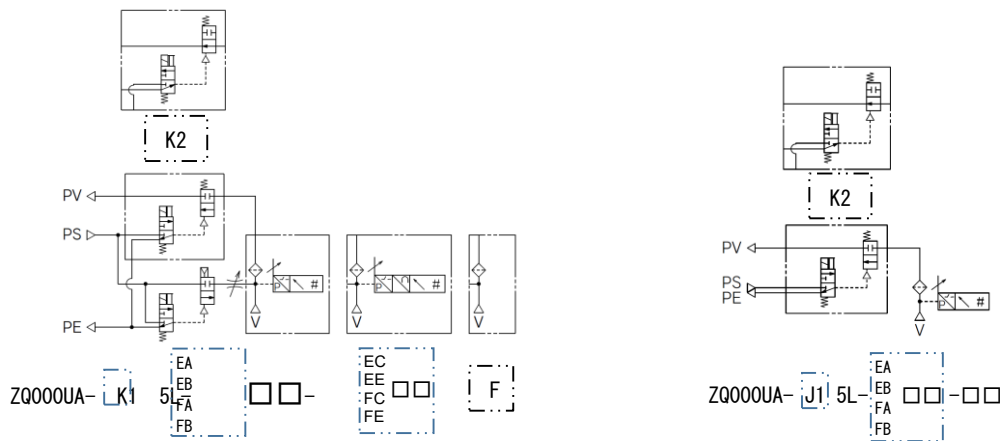

Vacuum ejector Manifold type (without the PD-port)

ZZQ1□A-BSB

*ZQ□3MA-K15L-□□□-□

*ZQ□3MA-K25L-□□□K-□

*ZQ□3MA-J15L-F-□

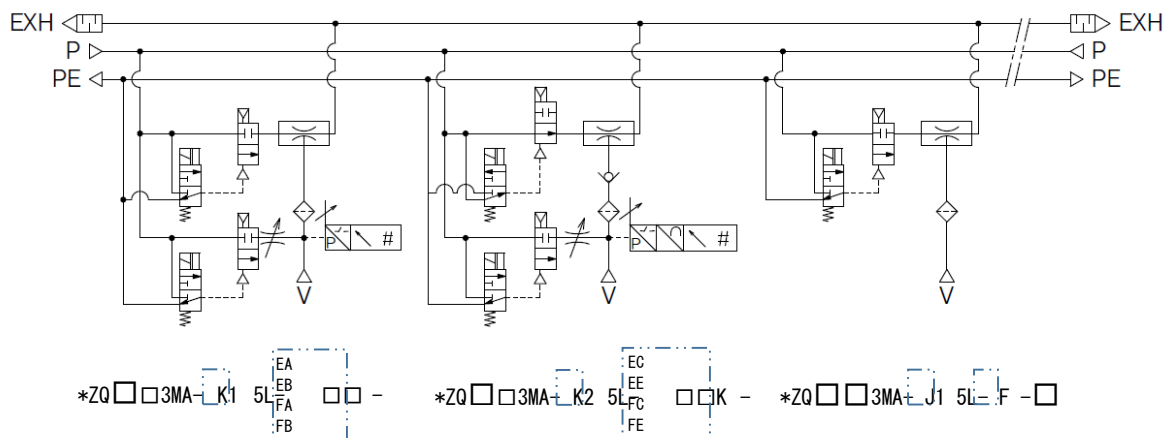

Vacuum ejector Manifold type (with the PD-port)

ZZQ1□A-BSC

*ZQ□3MA-K15L-□□□-□-S

*ZQ□3MA-K25L-□□□K-□-S

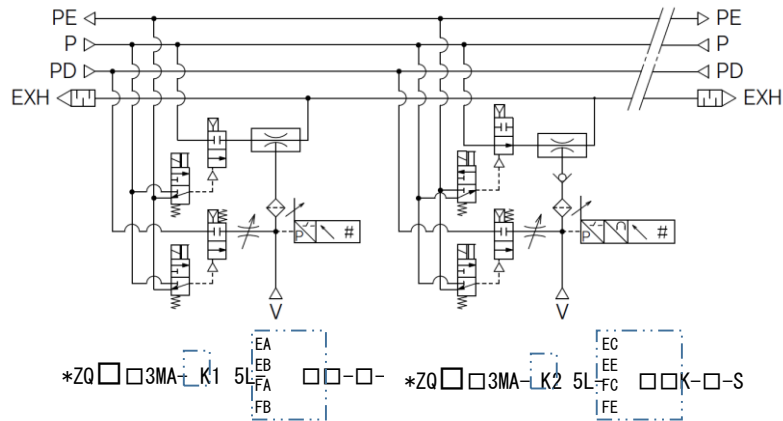

Vacuum pump system Manifold type (without the PD-port)

ZZQ1□A-ROB

*ZQ000MA-K15L-□□□-□

*ZQ000MA-K25L-□□□-□

*ZQ000MA-J15L-F-□

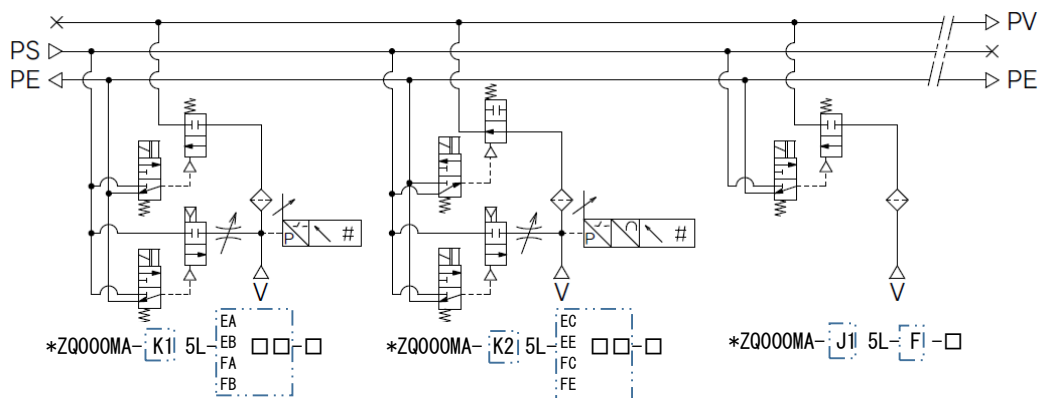

Vacuum pump system Manifold type (with the PD-port)

ZZQ1□A-ROC

*ZQ000MA-K15L-□□□-□-S

*ZQ000MA-K25L-□□□-□-S

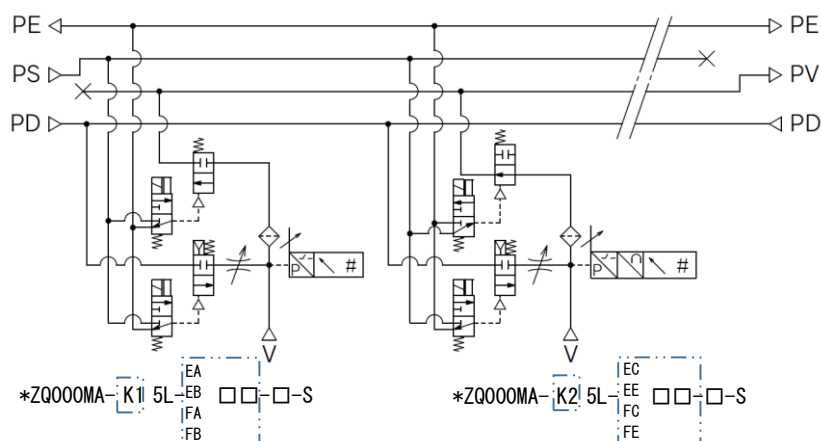

11. Exhaust Characteristics, Flow Characteristics, Vacuum Pump Flow Characteristics, and Vacuum Release Flow Rate Characteristics

11.1 Vacuum ejector exhaust characteristics / Flow characteristics (representative values)

ZQ05□A

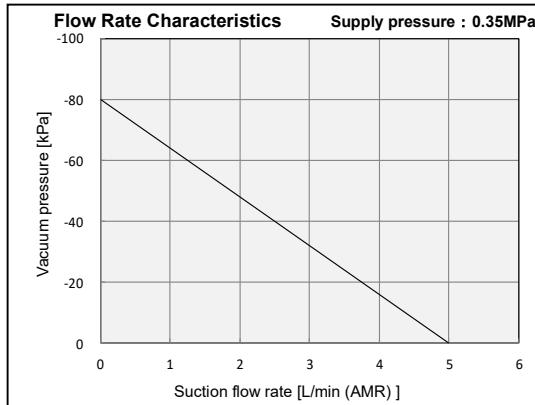
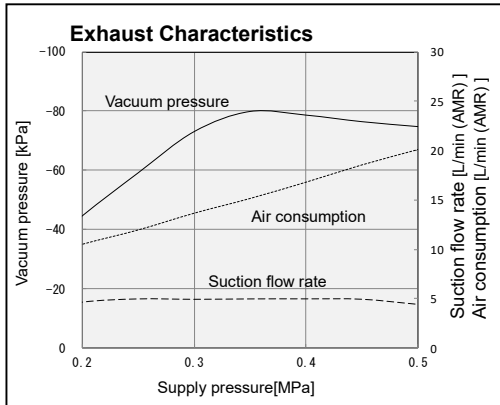

ZQ07□A

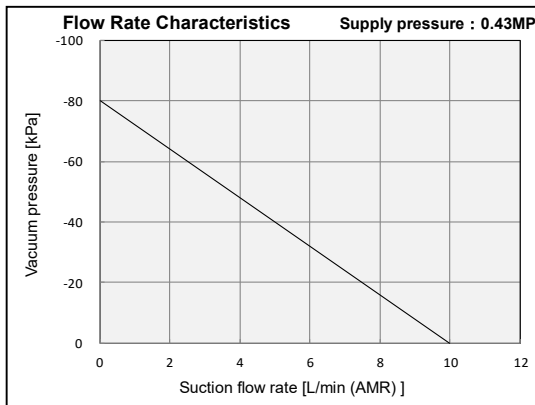
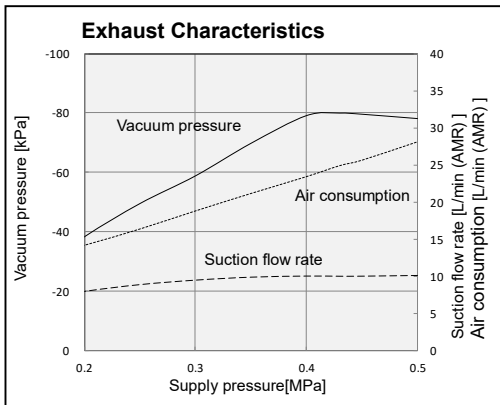

ZQ10□A

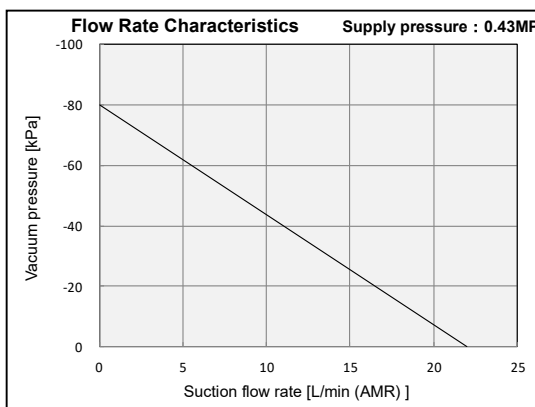
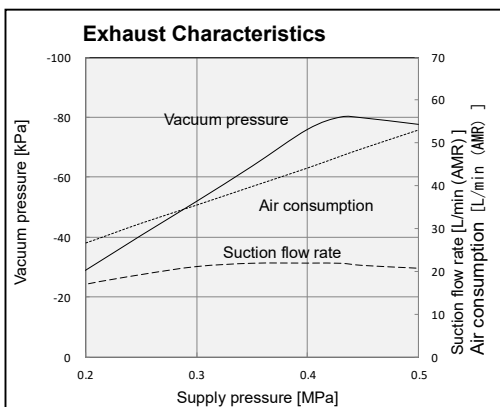

How to read flow characteristics

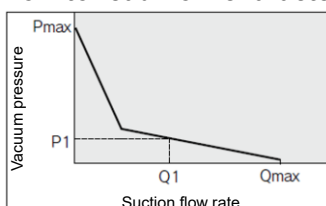

The flow characteristics curve shows the relationship between the vacuum pressure and the suction flow of the ejector. It shows that the vacuum pressure changes when the suction flow changes. In the graph on the left, Pmax means the maximum vacuum pressure and Qmax means the maximum suction flow. The value shown in this graph is what is shown in the catalog as the specifications. The changes in vacuum pressure are explained as follows:

- (1) When the suction port of the ejector is closed and sealed, the suction flow will be 0 and the vacuum pressure will reach its maximum (Pmax).
- (2) When the suction port is opened, air will flow. If there is leakage, the suction flow will increase, but the vacuum pressure will decrease. (State at P1 and Q1)
- (3) If the suction port then fully opened, the suction flow will reach its maximum (Qmax), but the vacuum pressure will become almost 0 (atmospheric pressure). Vacuum pressure will not increase much if an attempt is made to adsorb a breathable workpiece or a workpiece with a large amount of leakage. Attention should be paid in such cases.

11.2 Flow characteristics of the vacuum pump system (representative values)

ZQ000A

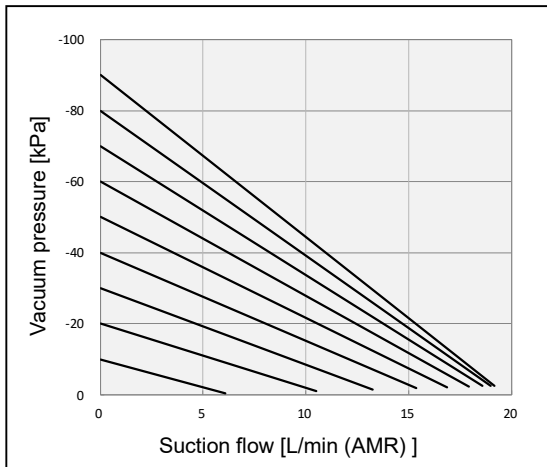

The flow rate at the final adsorbing part can vary depending on the piping conditions to the vacuum port. (This graph shows values when the V port with $\phi 6$ is used.)

11.3 Break Flow Rate Characteristics (representative value)

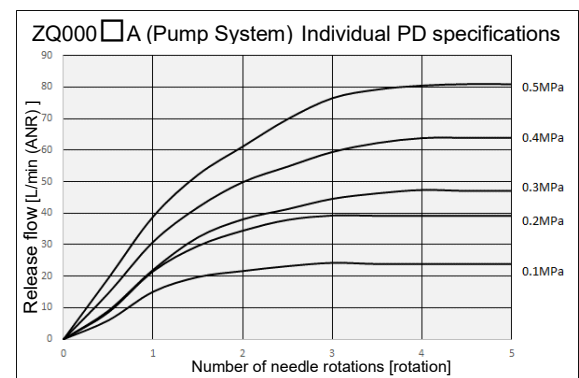
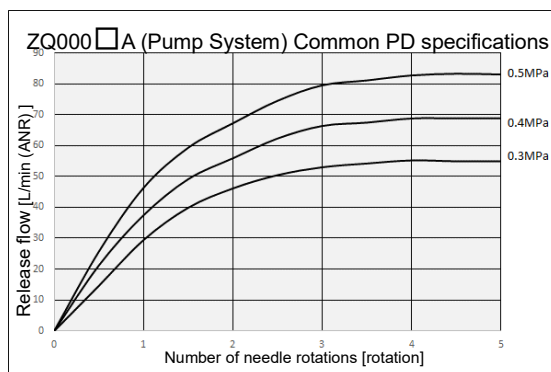
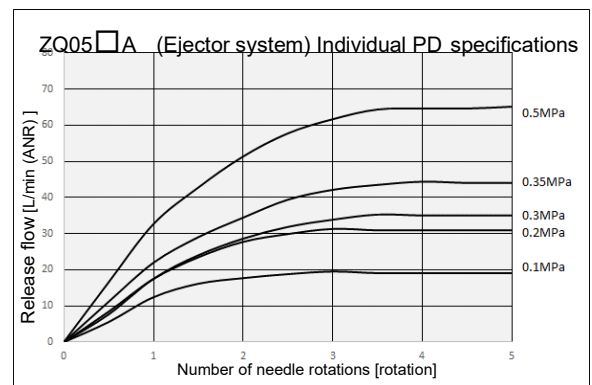
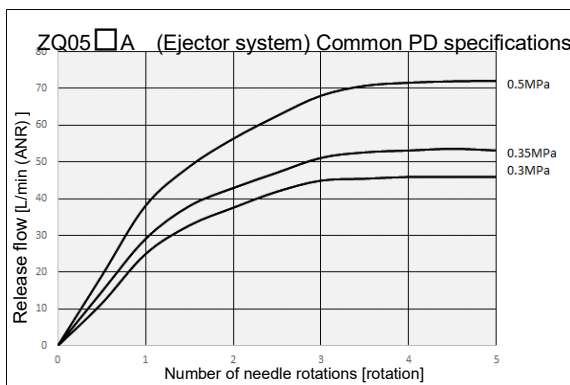

Maximum vacuum release flow rate

Vacuum release flow rates in product specifications and according to the V port size

[L/min (ANR)]

V Port Size	Supply pressure error [MPa]	ZQ05□A		ZQ07□A		ZQ10□A		ZQ000□A	
		Common PD	Individual PD	Common PD	Individual PD	Common PD	Individual PD	Common PD	Individual PD
ø3.2	0.1	-	16	-	14	-	11	-	23
	0.2	-	26	-	23	-	19	-	38
	0.3	39	31	35	28	29	22	52	43
	Standard supply pressure ^{Note 1)}	45	39	47	41	38	35	66	59
	0.5	61	57	53	50	43	41	79	76
ø 4	0.1	-	17	-	15	-	12	-	23
	0.2	-	28	-	25	-	21	-	39
	0.3	42	33	37	29	31	25	54	44
	Standard supply pressure ^{Note 1)}	47	40	50	38	42	40	68	61
	0.5	65	60	57	53	48	46	81	80
ø 6	0.1	-	19	-	18	-	15	-	24
	0.2	-	31	-	29	-	26	-	39
	0.3	46	35	43	33	38	30	55	47
	Standard supply pressure ^{Note 1)}	53	44	58	51	52	48	69	64
	0.5	72	65	66	62	59	56	83	81

Note 1) ZQ05□A : 0.35MPa、ZQ07□A、ZQ10□A : 0.43MPa、ZQ000□A : 0.4MPa

12. Handling Precautions

12.1 Exhaust from the Ejector

The exhaust resistance should be as small as possible to obtain the full performance of the ejector.

There should be no shield around the exhaust port for the silencer exhaust specification. Sound absorbing material is gradually clogged in the following cases:

- Suction of dust in the environment at the time of adsorption, or
- When the air is not clean enough.

Clogging causes resistance in the ejector's exhaust, decreasing suction flow and vacuum pressure. (Regular replacement of the sound absorbing material is recommended.)

For the port exhaust type, exhaust resistance occurs depending on the pipe size and length.

12.2 Exhaust Noise from the Ejector

When the vacuum ejector generates vacuum, noise can be heard from the exhaust port when the standard supply pressure is close to the pressure that generates peak vacuum pressure, making vacuum pressure unstable.

If the vacuum pressure range is adequate for adsorption, there should not be a problem. If the noise causes a problem or affects the setting of the pressure switch, change the supply pressure slightly to avoid the pressure range of the noise.

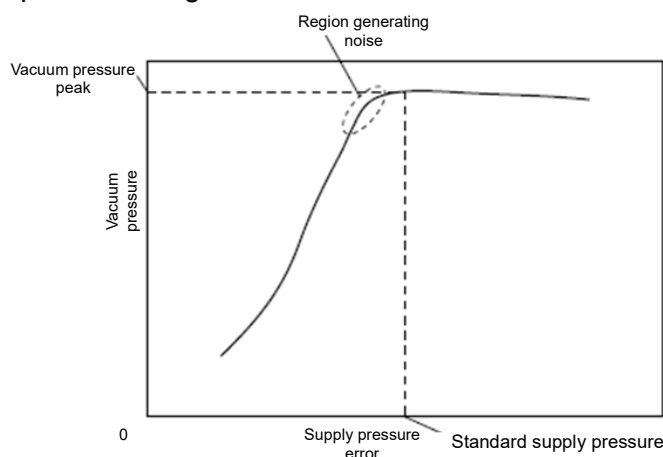

1 3 . Troubleshooting

If the product fails in any way, perform the following troubleshooting measures.

Failure phenomenon		Possible causes		Countermeasures
Vacuum absorption failure	Vacuum is not generated	Clogging by foreign matter or particles		See (1) and (2)
	Vacuum pressure decreased	Supply valve does not operate	Decline in the power supply voltage	See (3) and (4)
			Electrical wire failure	See (4) and (5)
			The supply pressure exceeds the operating pressure range.	See (6)
		Entry of oil mist	See (14)	
		Control failure	Simultaneous energization	See (7)
			Leakage voltage	See (8)
	Incorrect assembly during maintenance	Mounting failure of the gasket	See (9)	
			Insufficient supply pressure	See (6) and (10)
	Fluctuation of vacuum pressure	Noise is generated intermittently when air is exhausted when adsorbing and vacuum pressure slightly fluctuates.	Vibration of fluid when vacuum pressure is generated	
Air leakage from vacuum port	When using the manifold type, air flows from the vacuum port of the stopped product.	Exhaust air flows to the vacuum port		See (12)
Vacuum release failure	Release air is not output	Vacuum release flow adjusting needle is fully closed		See (13)
		Release valve does not operate		See (3), (4), (5), (6) and (14)
	Workpiece is not released smoothly.	Adhesion of the workpiece and pad		See (15)
		Control failure	Simultaneous energization	See (7)
Leakage voltage	See (8)			
Operation failure of the energy saving switch	Vacuum is not held. Supply valve chatters.	Vacuum leakage		See (16)

■ Countermeasures

No.	Countermeasures
(1)	Oil mist in the supply air or particles in the piping cause clogging if they enter the ejector. This may cause operation failure. Blow the air piping with air to eliminate particles. Installing the mist separator and air filter for cleaner supply air is recommended. Perform regular maintenance on the mist separator and filter. Refer to the product catalog or operation manual for details of the maintenance.
(2)	Substances adhering to the surface of the workpiece may enter the ejector, causing clogging. Install an air suction filter with high filtration accuracy in the piping of the pad and ejector to protect against foreign matter in the suction air (fine substances penetrating the built-in filter element). Perform regular maintenance on the filter. Refer to the product catalog or operation manual for details of the maintenance.
(3)	Adjust the rated voltage so that the supply voltage for the solenoid valve is within +/-10% of the rated voltage while the simultaneously energized equipment is ON. When the digital pressure switch is wired to the common power supply, the rated voltage shall be maintained while the switch is energized.
(4)	Check the correct connection of the power supply and wiring of plug connectors.
(5)	The connector assembly lead wire included with the product will break by repeated bending. When the ejector is installed onto the moving part, use the wiring intended for moving parts. Fix the wiring to the device so that it is not affected by vibrations.
(6)	If the supply pressure is lower than the operating pressure range, it may cause operation failure of the main valve. If the supply pressure is higher than the operating pressure range, it may cause operation failure due to early wear of seals. Adjust the supply pressure appropriate for the specification for each port. Ejectors (especially the manifold products) consume a large amount of air during operation. Ensure that the supply pressure is within the operating range.
(7)	Vacuum pressure decreases if the release valve is energized while the supply valve is operating. Check the control program and wiring.
(8)	Leakage voltage may cause the valve to malfunction. Keep the leakage voltage at 0.72 V or less.
(9)	The gasket came out or was displaced during filter element maintenance or the valve assembly replacement must be put back in the correct position before reassembly in order to avoid the leakage of vacuum or air during operation. In this case, disassemble the parts and reassemble the gasket correctly. If the gasket is lost or broken, replace it with a new one.
(10)	If the supply pressure during the operation of the ejector decreases, the generated vacuum pressure decreases. Use an adequate flow rate so that the supply pressure is satisfactory when other air equipment operates at the same time.

No.	Countermeasures
(11)	<p>When the ejector adsorbs the workpiece by generating a vacuum, high speed air coming out of the nozzle collides into the diffuser I.D. and bounces back, generating vibration in the exhaust air. Because of this, the vacuum pressure fluctuates slightly and is not stabilized.</p> <p>The workpiece can be adsorbed when the ejector is used in this condition. The phenomenon causes noise or could be a problem related to the setting of the vacuum switch. The noise can be eliminated by changing the supply pressure.</p> <p>Adjust the pressure regulating valve for supply pressure while checking the exhaust noise and vacuum pressure until the noise disappears.</p> <p>Ejector may generate noise due to the increase of exhaust resistance. When the silencer becomes dirty, replacement of the silencer element may improve the condition.</p>
(12)	<p>In case of centralized piping, the exhausted air flows back into the ejector exhaust path which is not operating, and is then exhausted from the vacuum port. In the case of a centralized manifold exhaust, air flow from the vacuum port can be reduced by selecting a product with a check valve. It is possible to order a single check valve.</p>
(13)	<p>Release air is not output if the vacuum release flow adjusting needle is fully closed. Adjust the needle to an appropriate position.</p>
(14)	<p>If oil mist enters the product, the grease of the valve assembly and main valve is washed away with the mist, adversely affecting the valve operation. In addition, the life of the main valve may be shortened. Install the mist separator and air filter to the supply air piping for the ejector.</p>
(15)	<p>The vacuum pad surface in contact with the workpiece deteriorates according to the number of contacts. The workpiece may not be contacted correctly if the surface is deteriorated due to the increase of the rubber viscosity. If the rubber viscosity increases, replace the pad.</p>
(16)	<p>The product with an energy saving switch reduces air consumption by stopping air supply by creating a vacuum between the check valve and pad in the ejector while adsorbing the workpiece. When the holding vacuum pressure decreases, the supply valve turns on at the previously set threshold to supply vacuum pressure so that the workpiece does not fall.</p> <p>Therefore, if the holding time is very short, turning it ON/OFF at a high frequency will cause a phenomenon like chattering. In this case, eliminate the leakage or cancel the energy saving setting. For how to release the setting, refer to the manual for the digital pressure switch for the vacuum ejector with energy saving function (ZQ-ZSV□□□□-A).</p>

Revision history

A'

P.22 Change of the spare part numbers for the solenoid valve

P.24 Change of the spare part numbers for the V port fitting

P.25 Change of the spare part numbers for the Washer assembly

P.27 P.28 Added items to 8. Maintenance

SMC Corporation

4-14-1, Sotokanda, Chiyoda-ku, Tokyo 101-0021 JAPAN

Tel: + 81 3 5207 8249 Fax: +81 3 5298 5362

URL <http://www.smcworld.com>

NOTE: Specifications are subject to change without prior notice and any obligation on the part of the manufacturer.

© 2019 SMC Corporation All Rights Reserved