



ORIGINAL INSTRUCTIONS

Instruction Manual

Residual pressure release valve with direct monitoring for use in safety related systems

(25A-)VG342(R)-X87(-##),

VG342R-X109,

VG342R-X111,

VG342R-X112,

VG342R-X113,

VG342R-X114,

VG342R-X116,

VG342R-X124,

VG342R-X133

Note) "###" and "##" represent numerical digits.

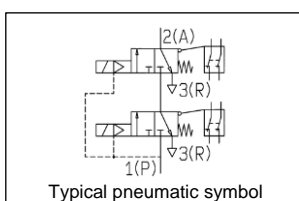

Safety component as defined by the Machinery Directive 2006/42/EC article 2c/ The Supply of Machinery (safety) Regulations 2008 part 2.4(2)(c)

The intended use of this valve is to vent a protected system to

atmosphere when it is de-energised. When properly integrated into a suitable safety system the valve is compatible for use in systems up to Category 4 as defined by EN ISO 13849-1:2015.

1 Safety Instructions

These safety instructions are intended to prevent hazardous situations and/or equipment damage. These instructions indicate the level of potential hazard with the labels of "Caution," "Warning" or "Danger."

They are all important notes for safety and must be followed in addition to International Standards (ISO/IEC) (1), and other safety regulations.

ISO 4414: Pneumatic fluid power - General rules relating to systems.

ISO 4413: Hydraulic fluid power - General rules relating to systems.

IEC 60204-1: Safety of machinery - Electrical equipment of machines. (Part 1: General requirements)

ISO 10218-1: Robots and robotic devices - Safety requirements for industrial robots - Part 1: Robots.

This manual contains essential information for the protection of users and others from possible injury and/or equipment damage.

Refer to product catalogue, Operation Manual and Handling Precautions for SMC Products for additional information.

Read this manual before using the product, to ensure correct handling, and read the manuals of related apparatus before use.

Keep this manual in a safe place for future reference.

To ensure safety of personnel and equipment the safety instructions in this manual must be observed, along with other relevant safety practices.

- Refer to product catalogue, Operation Manual and Handling Precautions for SMC Products for additional information.
- Read this manual before using the product, to ensure correct handling, and read the manuals of related apparatus before use.
- Keep this manual in a safe place for future reference.
- To ensure safety of personnel and equipment the safety instructions in this manual must be observed, along with other relevant safety practices.

Caution	Caution indicates a hazard with a low level of risk which, if not avoided, could result in minor or moderate injury.
Warning	Warning indicates a hazard with a medium level of risk which, if not avoided, could result in death or serious injury.
Danger	Danger indicates a hazard with a high level of risk which, if not avoided, will result in death or serious injury.

Warning

- The compatibility of the product is the responsibility of the person who designs the equipment or decides its specifications.

1 Safety Instructions - continued

Since the product specified here is used under various operating conditions, its compatibility with specific equipment must be decided by the person who designs the equipment or decides its specifications based on necessary analysis and test results. The expected performance and safety assurance of the equipment will be the responsibility of the person who has determined its compatibility with the product. This person should also continuously review all specifications of the product referring to its latest catalogue information, with a view to giving due consideration to any possibility of equipment failure when configuring the equipment.

- Only personnel with appropriate training should operate machinery and equipment.

The product specified here may become unsafe if handled incorrectly. The assembly, operation and maintenance of machines or equipment including our products must be performed by an operator who is appropriately trained and experienced.

- Do not service or attempt to remove product and machinery/equipment until safety is confirmed.

1) The inspection and maintenance of machinery/equipment should only be performed after measures to prevent falling or runaway of the driven objects have been confirmed.

2) When the product is to be removed, confirm the safety measures as mentioned above are implemented and the power from any appropriate source is cut, and read and understand the specific product precautions of all relevant products carefully.

3) Before machinery/equipment is restarted, take measures to prevent unexpected operation and malfunction.

- Do not use this product outside of the specifications.
- Contact SMC beforehand and take special consideration of safety measures if the product is to be used in any of the following conditions.

1) Conditions and environments outside of the given specifications or use outdoors or in a place exposed to direct sunlight.

2) Installation on equipment in conjunction with atomic energy, railways, air navigation, space, shipping, vehicles, military, medical treatment, combustions and recreation, or equipment in contact with food or beverages, emergency stop circuits, clutch and brake circuits in press applications, safety equipment or other applications unsuitable for the specification described in this document.

3) An application which could have negative effects on people, property or animals requiring special safety analysis outside the scope

of EN ISO 13849 described in this document.

4) Use in an interlock circuit, which requires the provision of double interlock for possible failure by using a mechanical protective function, and periodical checks to confirm proper operation.

- Always ensure compliance with relevant safety laws and standards.

- All electrical work must be carried out in a safe manner by a qualified person in compliance with applicable national regulations.

Caution

- The product is provided for use in manufacturing industries. This product must not be used in residential areas.

The product herein described is basically provided for peaceful use in manufacturing industries.

If considering using the product in other industries, consult SMC beforehand and exchange specifications or a contract if necessary.

If anything is unclear, contact your nearest sales branch.

2 Specifications

Warning

Special specification products "-X###" and "-##" other than standard "-X87" might have specifications different from those shown in this Instruction Manual.

Refer to individual drawings for special specifications.

2.1 Valve specifications

Type of actuation	Normally closed
Return method	Spring return
Fluid	Air
Proof pressure [MPa]	1.05
Operation pressure range [MPa]	0.25 to 0.7
External pilot pressure [MPa]	0.25 to 0.7 (same as main pressure)
Ambient and operating fluid temperature [°C]	-10 to 50 (no freezing / no condensation)
Ambient humidity	95% RH or less (no condensation)
Lubrication	Not required (Note 1)
Operating frequency: Max	30 cycles per minute
Operating frequency: Min	1 cycle per week (Note 2)

2 Specifications - continued

Duty cycle	Contact SMC	
Response time	See 2.10.2.1	
Impact / Vibration resistance [m/s ²] (Note 3)	150/50 (Note 4) 5)	
Air quality	5 μm filtration or smaller	
Environment	Indoor use only	
Enclosure (based on IEC60529)	IP 40	
B _{10D} [cycles]	1,000,000 (Note 6)	
Mission time [years or cycles]	Maximum 20 years or when the number of cycles = B _{10D} , whichever occurs first (Note 7)	
Mass [kg]	Internal pilot	2.8 (1" port size: 3.2)
	External pilot	2.9 (1" port size: 3.3)

Table 1.

Note 1) If lubrication is used in the system, use class 1 turbine oil (no additive), ISO VG32.

Note 2) The valve must be cycled (energised and then de-energised) at least once per week. There is an additional functional check procedure in 6.3.

Note 3) See section 2.4 for switch impact/vibration specifications.

Note 4) Impact resistance:

- No malfunction resulted from the impact test using a drop impact tester.
- The test was performed in both energised and de-energised states to the axis of and at right angles to the direction of the main valve and armature (Values quoted are for a new valve).

Note 5) Vibration resistance:

- No malfunction occurred in a one-sweep test between 8.3 and 2000 Hz.
- Test was performed in both energised and de-energised states to the axis of and at right angles to the direction of the main valve and armature (Values quoted are for a new valve).

Note 6) The B_{10D} figure is estimated from SMC life tests under SMC test conditions.

Note 7) See section 2.9.4 for details.

2.2 Flow characteristics

Series	Flow rate characteristics					
	1→2 (P→A)			2→3 (A→R)		
	C [dm ³ /(s·bar)]	b	Cv	C [dm ³ /(s·bar)]	b	Cv
VG342-06-X87	26.6	0.04	5.5	28.6	0.03	5.6
VG342-10-X87	25.5	0.03	5.4	27.4	0.01	5.3

Table 2.

Note) The air supply flow is from port 1 to port 2. The ports on the valve are

clearly identified with the corresponding numbers.

2.3 Pilot valve specification

Electrical entry	DIN type industry standard B 11mm pitch connector
Coil rated voltage [VDC]	24
Allowable voltage fluctuation	-15% to +10% (Note 1)
Power consumption [W]	2.2 per solenoid
Protection circuit	With indicator light & surge suppressor
Surge voltage suppressor	Diode

Table 3.

Note 1) Valve state is not defined if electrical input is outside of specified operating ranges.

2.4 Limit switch specification

	Omron	Rockwell Automation
Electrical entry	G1/2 conduit M12 connector	M12 connector
Contact resistance [mΩ]	25 max	50 max
Minimum permissible load	5 VDC 1mA (resistive load)	5 VDC 5mA (resistive load)
Rated voltage [VDC]	24	
Maximum permitted load current [mA]	50 (Note 1)	
Maximum permitted load inductance [H]	0.5 (Note 1)	
Rated insulation voltage [V]	300	600
Electric shock protection class	Class II (EN 60947-5-1)	
Pollution degree	Level 3 (EN 60947-5-1)	
Impact / Vibration resistance	See note 2, 3)	

Table 4.

Note 1) For the purposes of EN ISO 13849-2:2012 table D.2 the switch is de-rated from the figures specified by the switch manufacturer. The switch load must be limited in the application in order to maintain the specified safety performance, including the B_{10D} and mission time.

Note 2) The Omron switch is subject to the following vibration and impact limitations specified by the manufacturer:

- Contact opening time should be less than a 1 ms pulse under vibration of 0.75 mm single amplitude, 10 to 55 Hz, 10 cycles in each direction for 45 minutes.
- Impact: 300 m/s² (Contact open time: 1 ms maximum pulse).

2 Specifications - continued

Note 3) The Rockwell Automation switch is subject to the following vibration and impact limitations specified by the manufacturer:

- Impact: IEC60068-2-7 (30gn (300m/s²), 3 pulses per axis).
- Vibration: IEC60068-2-6 (10...55Hz, 0.35mm amplitude).

2.5 Safety specification

- Safety function: When the valve is de-energised, the protected circuit is vented to atmosphere.
- The product is compatible for use in systems up to Category 4 according to the Safety Standard when integrated into a suitable safety system.
- In this section, 'the Safety Standard' refers to EN ISO 13849-1 and 'the Validation Safety Standard' refers to EN ISO 13849-2 as referenced in the Declaration of Conformity.
- Information about compatibility with the Safety Standard is given in section 2.9.

2.6 Pneumatic symbols (examples)

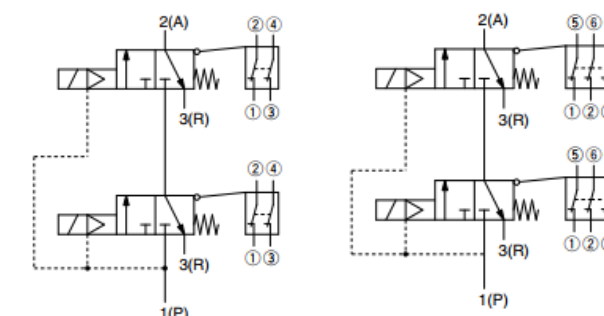

Figure 1. Internal pilot, Omron option Figure 2. Internal pilot, Rockwell option

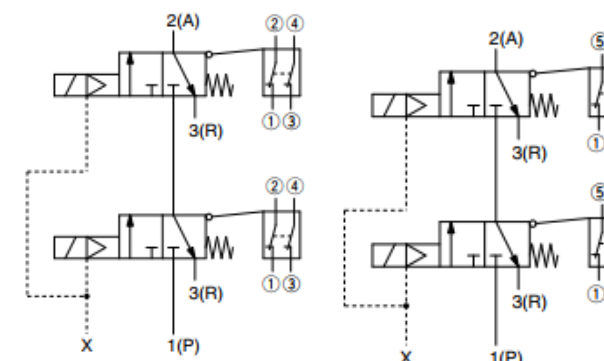

Figure 3. External pilot, Omron option Figure 4. External pilot, Rockwell option

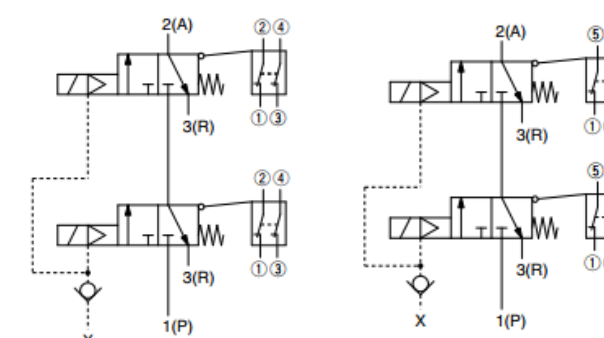

Figure 5. External pilot with check valve Figure 6. External pilot with check valve

2 Specifications - continued

2.7 Declaration of Conformity

Figure 7.

2 Specifications - continued

Statutory instrument	Requirements	Designated Standards/ Technical Specifications
Supply of Machinery (Safety) Regulations 2008	Schedule 2	EN ISO 13849-1:2015 EN ISO 13849-2:2012 EN ISO 4414:2010
Electromagnetic Compatibility Regulations 2016	Schedule 1	EN 61000-6-2:2005
The Restriction of the Use of Certain Hazardous Substances in Electrical and Electronic Equipment Regulations 2012	Schedule 2	EN IEC 63000:2018

Figure 9.

2 Specifications - continued

2.9.2 Valve and switch response

- The valve response time ON (T1) depends on the supply pressure and the volume of the protected system. T1 times are not related to the safety function.
- The valve response time OFF (T2) depends on the volume (V) and the flow capacity of the protected system. It is defined as the time interval in which the pressure in a test volume connected to an outlet port of the valve reduces from 0.63 MPa to 0.05 MPa in response to a change in the control signal to that valve. Refer to table below for indicative values under SMC conditions.
- The ON response time of the limit switch (T3) is shown in the table below.
- The OFF response time of the limit switch (T4) is shown in the table below.

Caution

- Response time values are for reference only and it is the system integrator's responsibility to obtain the actual values.

Volume / litre	Valve OFF response / T2, ms	Switch Response	
		T3, ms	T4, ms
3	420	35	120
38	4480		

Table 6.

Caution

- Response times are based on tests under SMC conditions and are not guaranteed. Always observe the terms of 2.9.3.
- Exhaust times will increase when only one channel is functioning in a fault condition.

2.9.3 Relationship of flow and response performance to safety function

- The safety function is to vent the compressed air in the protected system so that the protected system does not present a hazard when the application operates under the control of a suitable safety system.
- The time taken for the air to vent and remove the hazard is a function of:
 - The flow capacity of the valve
 - The flow restriction of silencers fitted to the valve

- The volume of the protected system
- The pressure of the air in the protected system
- The flow restrictions in the protected system
- The end user is expected to establish the time taken to vent the application system and ensure that this time is consistent with the requirement of the overall safety system. This includes the selection of suitable silencers.
- The performance of the system should be validated by test after each installation to ensure that the actual performance of the valve is consistent with the safety function. Validate the performance of the system under all foreseeable operating conditions of pressure, flow and volume.

2.9.4 Mission time according to the Safety Standard

The operational life of the product shall be limited to the mission time stated in section 2.1. The user is expected to calculate an equivalent figure in time units from the B_{10D} value based on the operating cycles of the application. In no circumstances can the mission time exceed 20 years. After the mission time has expired for the component, it shall be replaced with a new unit.

2.9.5 MTTFD according to the Safety Standard

The B_{10D} for the component given in section 2.1 is derived from product knowledge and based on specific life tests. The system integrator should use this data to determine MTTFD and the Performance Level (PL) of the system using the methods described in the Safety Standard.

2.9.6 Diagnostic Coverage according to the Safety Standard

These valves are fitted with 'direct monitoring' according to Table E1 of EN ISO 13849-1. When properly integrated this valve can contribute to a DC value of 99% to the DCavg for the complete safety function.

2.9.7 Common Cause Failures according to the Safety Standard

- CCF analysis is the responsibility of the system integrator.
- This valve has 2 channels made of identical valves.
- The use of this valve might not allow the system calculation to include CCF points for diversity.

2.8 Batch code

The batch code indicated in the product label translates to construction year / month according to the following table (eg. "AQ = Mar 2022):

Construction Year / Month	Production batch codes											
	Jan	Feb	Mar	Apr	May	Jun	Jul	Aug	Sep	Oct	Nov	Dec
2022	Ao	AP	AQ	AR	AS	AT	AU	AV	AW	AX	Ay	AZ
2023	Bo	BP	BQ	BR	BS	BT	BU	BV	BW	BX	By	BZ
...
2026	Eo	EP	EQ	ER	ES	ET	EU	EV	EW	EX	Ey	EZ

Table 5.

2.9 Safety system

2.9.1 Timing diagram

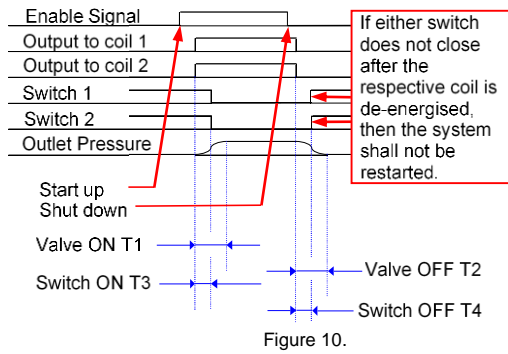

Figure 10.

Note: The monitor switches are Normally Closed, i.e. closed when the valve solenoids are de-energised. The monitor signals are therefore shown 'High' when the valve is de-energised.

3 Installation

3.1 Installation

Warning

- Do not install the product unless the safety instructions have been read and understood.
- Do not install the product if it appears to have been damaged during transport.
- The valve must be protected from contamination from the downstream system when air is vented through the valve.
- Do not paint the product.
- Do not remove or cover up warnings or specifications printed or affixed to the product.
- Ensure sufficient space for maintenance activities. When installing the products, allow access for maintenance.
- Ensure that the connections of pipework and cables to the unit do not result in a residual trip hazard to system operators or maintainers.
- If air leakage increases or equipment does not operate to specification, stop operation.
- Check mounting conditions when air and power supplies are connected. Initial function and leakage tests should be performed after installation.

3.2 Environment

Warning

- Do not use in an environment where corrosive gases, chemicals, salt water or steam are present.
- Do not use in an explosive atmosphere.
- Do not expose to direct sunlight. Use a suitable protective cover.
- Do not install in a location subject to vibration or impact in excess of the product's specifications.
- Do not mount in a location exposed to radiant heat that would result in temperatures in excess of the product's specifications.
- Do not install in a location subject to strong magnetic fields.
- Do not install in an EMC environment other than 'industrial' according to the scope of standard listed on the Declaration of Conformity.
- If it is used in an environment where there is possible contact with oil, weld spatter, etc., exercise preventive measures.
- When the solenoid valve is mounted in a control panel or is energised for a long time, make sure ambient temperature is within the specification of the valve.

- Ambient humidity
When using the valve in environments with low humidity, take measures to prevent static.
If the humidity rises, take measures to prevent the adhesion of water droplets on the valve.
Do not use in high humidity environment where condensation occurs.
- Altitude limitation is 1000 m above sea level.

3.3 Piping

Caution

- Before connecting piping make sure to clean up chips, cutting oil, dust etc.
- When installing piping or fittings, ensure sealant material does not enter inside the port. When using seal tape, leave 1 thread exposed on the end of the pipe/fitting.
- Tighten fittings to the specified tightening torque.

Port	Connection thread size (R, NPT)	Tightening Torque [N·m]
X (External pilot)	1/8	3 to 5
1 (P), 2 (A), 3 (R) for VG342-06	3/4	28 to 30
1 (P), 2 (A), 3 (R) for VG342-10	1	36 to 38

Table 7.

- The valve must be protected from contamination from the downstream system when air is vented through the valve.
- If no external pilot check valve is selected, supply port thread and external pilot port thread will be of the same type.
External pilot port size: 1/8".

3.4 Lubrication

Caution

- SMC products have been lubricated for life at manufacture, and do not require lubrication in service.
- If a lubricant is used in the system, use turbine oil Class 1 (no additive), ISO VG32. Once lubricant is used in the system, lubrication must be continued because the original lubricant applied during manufacturing will be washed away.

3 Installation - continued

3.5 Air supply

Warning

- Please consult with SMC when using the product in applications other than compressed air.
- Compressed air containing a large amount of water vapour can cause malfunction of pneumatic equipment. An air dryer or water separator should be installed upstream from filters.
- If condensation in the drain bowl is not emptied on a regular basis, the bowl will overflow and allow the condensation to enter the compressed air lines causing malfunction of pneumatic equipment.
- If the drain bowl is difficult to check and remove, installation of a drain bowl with an auto drain option is recommended.
- Use clean air. If the compressed air supply includes chemicals, synthetic materials (including organic solvents), salinity, corrosive gas etc., it can lead to damage or malfunction.
- The external pilot variant has 2 pilot ports. Both pilot ports need to be connected to an air supply for the valve to function.

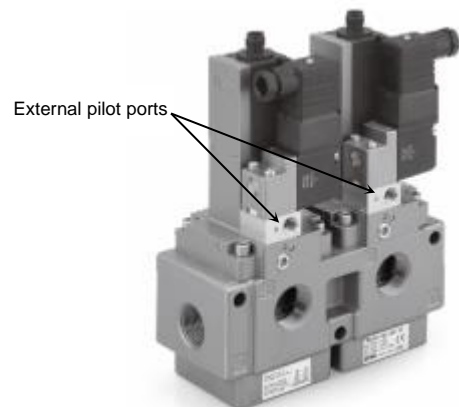

Figure 11.

Caution

- The air supply to the valve must be large enough to operate the valve and to deal with possible transient pressures. The recommended piping size is 3/4" or larger with a minimum I.D. of 19 mm or larger.
- The minimum I.D. should be 19 mm for the internal pilot variant. If 19 mm is not possible, the external pilot variant should be used. When the external pilot variant is used, ensure the pilot supply is not subject to transient pressures that might interfere with the function of the valve.
- Ensure a constant pressure of 0.25 MPa or more.
- When selecting a regulator or a filter regulator, use piping larger than the recommended size with sufficient flow rate characteristics.
- For extended piping between the regulator and the valve (inlet piping), keep piping as short as possible (2 m or less).
- For use under conditions other than those listed above, please use the external pilot type.
- When extremely dry air is used as the fluid, degradation of the lubrication properties inside the equipment may occur, resulting in reduced reliability (or reduced service life) of the equipment. Please consult with SMC.
- Install an air filter upstream near the valve. Select an air filter with a filtration size of 5 µm or smaller.
- Take measures to ensure air quality, such as by installing an aftercooler, air dryer, or water separator.
- Compressed air that contains a large amount of drainage can cause malfunction of pneumatic equipment such as valves.
- If excessive carbon powder is seen, install a mist separator on the upstream side of the valve.
- If excessive carbon dust is generated by the compressor it may adhere to the inside of a valve and cause it to malfunction.
- When using the external pilot type valve, it is recommended that the main supply pressure and the pilot pressure are taken from separate lines. The A/B options are available which have a check valve fitting in the pilot port (see "How to order" in catalogue or drawing).
- If necessary, a check valve can be installed in the external pilot line to prevent a drop in pilot pressure.

Warning

- If a check valve is fitted to the external pilot supply, ensure there is no hazard created by any air trapped between the check valve and the pilot valves.

3 Installation - continued

- Minimise the distance between the valve and the air supply and between the valve and the protected system. Do not place any devices between the valve and the protected system that might interfere with the safety function. The exhaust ports of the valve should not be left unconnected.
- The exhaust ports of the valves should never be blocked and must be protected from ingress of contamination by a suitable silencer or device which does not affect the valve function.

3.6 Mounting

- Mounting orientation: Unrestricted.
- The valve can be mounted using 3 x M8 bolts.

Caution

- Tighten bolts to achieve a secure mounting. Maximum torque 25 N·m.
- 1" port size option uses adaptors. Do not remove adaptors.
- 3/4" port size option does not have adaptors.
- The pilot supply ports are 1/8" where applicable.

3.7 Noise

Caution

- It is recommended that silencers or noise reduction devices are fitted to protect personnel from transient noise when the valves are de-energised.
- The recommended silencer is ANA1-06 for 3/4" port and ANA1-10 for 1" port.
- The pressure drop of silencers or devices must be taken into account during the design and testing of the application system to ensure that the safety function is maintained.

3.8 Electrical connection

Caution

- When electric power is connected to a solenoid valve, be careful to apply the proper voltage. Improper voltage may cause malfunction or coil damage.
- Check if the connections are correct after completing all wiring.

3.8.1 Pilot valve

3.8.1.1 Surge voltage suppression

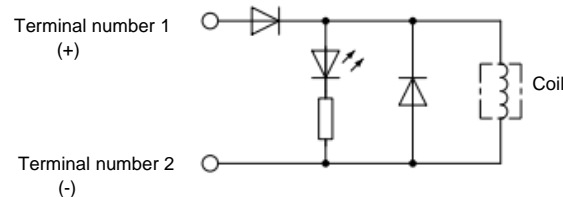

Figure 12.

3.8.1.2 Pilot valve connections

Terminals with light and surge protection have built in wiring connections. Connect as per figure.

Terminal No.	1	2
Polarity	+	-

Applicable cable dia: Ø4.5 ~ Ø7 mm

Figure 13.

3.8.1.3 Using DIN connector with the pilot valve

Caution

Connection

- 1) Loosen the holding screw and pull the connector out of the solenoid valve terminal block.
- 2) After removing the holding screw, insert a flat head screwdriver, etc. into the notch on the bottom of the terminal block and pry it open, separating the terminal block and the housing.

3 Installation - continued

- 3) Loosen the terminal screws (slotted screws) on the terminal block, insert the cores of the lead wires into the terminals according to the connection method, and fasten them securely with the terminal screws. Loosen the screw in the terminal block. Insert the lead core wires into the terminals and secure the wires by re-tightening the terminal screws. As the product has polarity, be sure to wire the product correctly in accordance with the terminal number symbols of the terminal block while referring to the electric circuit diagram.
- 4) Secure the cord by fastening the ground nut.

Caution

- When making connections, take note that using other than the supported size (Ø4.5 to Ø7) heavy duty cord will not ensure adequate sealing.
- Also, be sure to tighten the gland nut and holding screw within their specified torque ranges.
- Ensure sealing gaskets are correctly installed.

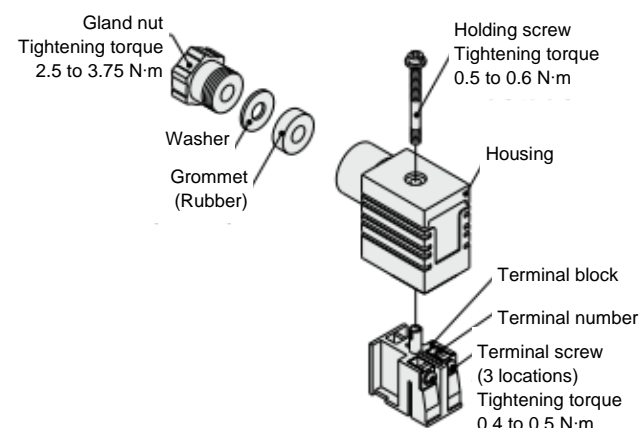

Figure 14.

Warning

The ground terminal is connected to the coil assembly only and does not provide a protective earth for the body of the valve.

Changing the entry direction

After separating the terminal block and housing, the cord entry can be changed by attaching the housing in the desired direction (4 directions at 90° intervals).
* When equipped with a light, be careful not to damage the light with the cord's lead wires.

Precautions

Plug in and pull out the connector vertically without tilting to one side.

Compatible cable

Cord O.D.: Ø4.5 to Ø7
(Reference) 0.5 to 1.5 mm², 2-core or 3-core, equivalent to JIS C 3306

Applicable crimped terminals

O-terminals: Equivalent to R1.25-4M defined in the JIS C 2805
Y-terminals: Equivalent to 1.25-3L made by J.S.T. Mfg. Co., Ltd.
Rod-terminals: Up to size 1.5

3.8.2 Omron limit switch: conduit type

3.8.2.1 Limit switch screw tightening torque

Screw position	Tightening torque [N·m]
Terminal screw	0.6 to 0.8
Cover clamping screw	0.5 to 0.7
Conduit mounting connection	1.8 to 2.2

Table 8. Conduit terminals tightening torque

3.8.2.2 Wiring

- When connecting to the terminals via insulating tube and M3.5 crimp terminals, arrange the crimp terminals as shown below so that they do not rise up onto the case or the cover. Application lead wire size: AWG20 to AWG18 (0.5 to 0.75 mm²)

3 Installation - continued

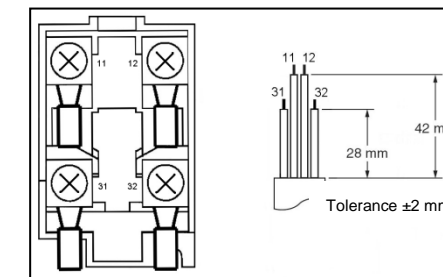

Figure 15.

- Do not push crimp terminals into gaps in the case interior. Doing so may cause damage or deformation of the case.
- Use crimp terminals not more than 0.5 mm in thickness. Otherwise, they will interfere with other components inside the case. The crimp terminal shown below are not more than 0.5 mm thick.

Manufacturer	Type	Wire size
J.S.T.	FV0.5-3.7 (F type) V0.5-3.7 (straight type)	AWG20 (0.5 mm ²)

J.S.T. is a Japanese manufacturer.

Table 9.

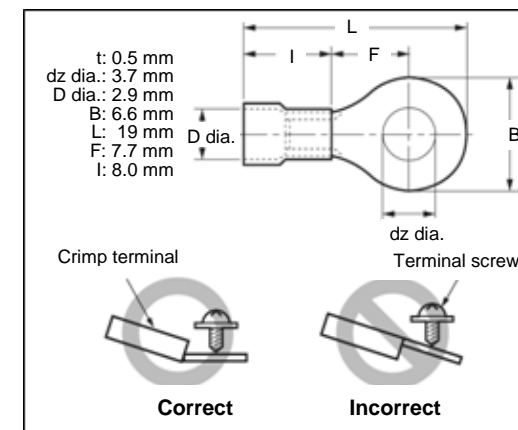

Figure 16.

3.8.2.3 Conduit opening

- Connect a recommended connector to the opening of the conduit and tighten the connector to the specified torque. The case may be damaged if an excessive tightening torque is applied.
- Use a cable with a suitable diameter for the connector.

3.8.2.4 Recommended connectors

- Use connectors with screws not exceeding 9 mm, otherwise the screws will protrude into the case interior, interfering with other components in the case. The connectors listed in the following table have connectors with thread sections not exceeding 9 mm. Use the recommended connectors to ensure conformance to the stated IP level.

3 Installation - continued

Size	Manufacturer	Model	Applicable cable diameter
G 1/2	LAPP	ST-PF1/25380-1002	6.0 to 12.0 mm
	Ohm Denki	OA-W1609	7.0 to 9.0 mm
		OA-W1611	9.0 to 11.0 mm

LAPP is a German manufacturer.
Ohm Denki is a Japanese manufacturer.

Table 10. Recommended conduit connectors

- Use LAPP connectors together with seal packing (JPK-16, GP-13.5, GPM20, or GPM12), and tighten to the specified tightening torque. Seal packing is sold separately.

3.8.3 Omron limit switch: M12 connector type

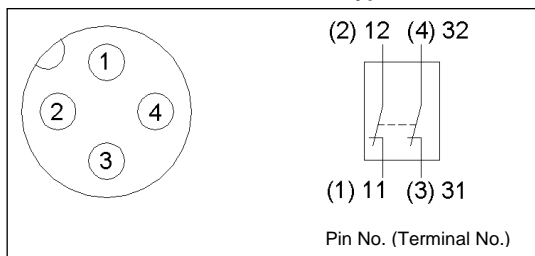

Figure 17.

Orientation of the M12 connector is not guaranteed. Only a straight connector should be used.

3.8.4 Rockwell Automation limit switch: M12 connector type

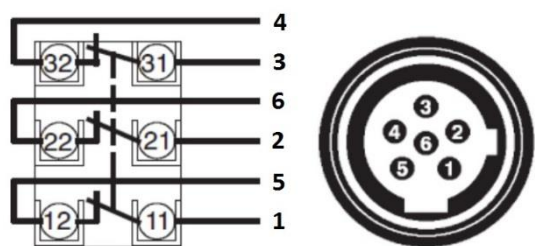

Figure 18.

3.8.4.1 Socket tightening

- Turn the socket connector screws by hand and tighten until no space remains between the socket and the plug.
- Make sure that the socket connector is tightened securely. Otherwise, the rated degree of protection may not be maintained and vibration may loosen the socket connector.
- Orientation of the M12 connector is not guaranteed. Only a straight connector should be used.

3.9 Residual voltage

Caution

- The suppressor arrests the back EMF voltage from the coil to a level in proportion to the rated voltage.
- Ensure the transient voltage is within the specification of the host controller.
- In the case of a diode, the residual voltage is approximately 1 V.
- Valve response time is dependent on surge suppression method selected.

3.10 Extended periods of continuous energization

Warning

- If a valve is continuously energized for an extended period of time, the temperature of the valve will increase due to the heat generated by the coil assembly.

4 How to Order

Refer to catalogue for standard VG-X87 valves or to drawings for specials "-X###" or "-X87-##" other than "-X87".

Note) The 25A- variants are compatible for use in the secondary battery manufacturing environment. These variants are copper and zinc free and suitable for use with low dew point air supplies. Contact SMC for more information.

5 Outline Dimensions

Refer to catalogue for standard VG-X87 valves or to drawings for specials "-X###" or "-X87-##" other than "-X87".

6 Maintenance

6.1 General maintenance

Caution

- Not following proper maintenance procedures could cause the product to malfunction and lead to equipment damage.
- If handled improperly, compressed air can be dangerous.
- Maintenance of pneumatic systems should be performed only by qualified personnel.
- Before performing maintenance, turn off the power supply and be sure to cut off the supply pressure. Confirm that the air is released to atmosphere.
- After installation and maintenance, apply operating pressure and power to the equipment and perform appropriate functional and leakage tests to make sure the equipment is installed correctly.
- If any electrical connections are disturbed during maintenance, ensure they are reconnected correctly and safety checks are carried out as required to ensure continued compliance with applicable national regulations.
- Do not make any modification to the product.
- Do not disassemble the product, unless required by installation or maintenance instructions.

6.2 Maintainable parts

Warning

- Under no circumstances attempt to change the solenoid of the pilot valve as this is an integral part of the valve and doing so will invalidate

SMC warranty.

- Do not attempt to replace the limit switches. M4 limit switch retaining screws are secured into position with adhesive, do not remove.
- There are no replaceable parts on these safety products.

6.3 Periodic testing

- The product should be tested for proper operation of the safety function once per month or whenever considered necessary for the purposes of the end user. The test should consist of operation of the safety system and observation of the following:

When the connected control system is energising the solenoids:

- Check that the solenoid indicator lights are illuminated.
- Check that the connected downstream system is properly pressurised.
- Check that the switch contacts are open.
- Check that when only one channel of the system (one of the solenoids) is energised the protected system does not become pressurised. Check this for both channels.

When the connected control system is not energising the solenoids:

- Check that the solenoid indicator lights are not illuminated.
- Check that the connected downstream system is properly vented to atmosphere and ensure that the condition of the silencers is not causing an extension of the vent time.
- Check that the switch contacts are closed.
- Check that when only one channel of the system (one of the solenoids) is de-energised the protected system is vented to atmosphere. Check this for both channels.

Warning

The specification of the valve requires the valve to be cycled (energised and de-energised) at least once per week.

6.4 Silencers

Warning

- Ensure that any silencers fitted to the valve remain clean and uncontaminated in operation because blockage will affect the safety function.

6 Maintenance - continued

- Examine any silencers at least once per month and more frequently if necessary due to the nature of the application environment.

6.5 Troubleshooting guide

Symptom	Possible fault	Action
Valve does not open	Pilot valve is not energised	Check pilot solenoid indicator (light) is illuminated and that voltage is within specification
	Supply pressure is too low	Check supply pressure
	Pilot valve has failed	Replace the entire unit
Valve does not close	Pilot valve remains energised	Check pilot solenoid indicator (light)
	Pilot valve is jammed	Replace the entire unit
	Main valve is jammed	Replace the entire unit
	Supply pressure is too high	Check supply pressure
Switch contacts do not open	Switch has failed	Replace the entire unit
Switch contacts do not close	Switch has failed	Replace the entire unit
Valve operation is noisy or erratic	Supply flow is inadequate	Increase supply pressure and/or flow
	Supply flow is inadequate	Increase supply pressure and/or flow.
Valve is slow to pressurise protected system	One channel of valve is not functioning	Check 'Valve does not open' symptoms above
	Inadequate flow area in protected system	Revise flow in protected system
Valve is slow to vent protected system	One channel of valve is not functioning	Check 'Valve does not close' symptoms above

Note: If one channel fails in a duplex valve, replace the entire unit.

Table 11.

7 Limitations of Use

Danger

The machine designer is responsible for ensuring that the operation of this device is compatible with relevant safety regulations.

Warning

The system designer should determine the effect of the possible failure modes of the product on the system.

7.1 Limited warranty and disclaimer/compliance requirements

Refer to Handling Precautions for SMC Products.

7.2 Holding of pressure

Warning

Since valves are subject to air leakage, they cannot be used for applications such as holding pressure (including vacuum) in a system.

7.3 Safety relays or PLC

Warning

- A safe output from a safety relay or PLC is used to operate this valve, ensure that any output test pulse duration is shorter than 1 ms to avoid the valve solenoid responding.
- The diagnostic switches should be wired to the safety input of the PLC.

7.4 Leakage voltage

Caution

Ensure that any leakage voltage caused by the leakage current when the switching element is OFF causes $\leq 3\%$ of the rated voltage across the valve.

7.5 Low temperature operation

Caution

Unless otherwise indicated in the specifications for each valve, operation is possible to -10°C , but appropriate measures should be taken to avoid solidification or freezing of drainage and moisture, etc.

7 Limitations of Use - continued

7.6 EMC restrictions

7.6.1 Class and Group Description

- This product is group 1, class A equipment according to EN55011.
- Group 1 equipment does not intentionally generate radio-frequency energy in the range 9kHz to 400 GHz.
- Class A equipment is equipment suitable for use in all locations other than those allocated in residential environments and those directly connected to a low voltage power supply network which supplies buildings used for domestic purposes.

Caution

- This equipment is not intended for use in residential environments and may not provide adequate protection to radio reception in such environments.

7.7 Limitations

Caution

- For the VG342-X87 internal pilot type, even when the inlet pressure is within the operating pressure range, restricted piping, etc., may cause reduced flow on the inlet side, leading to the valve not operating properly.
- The product may not operate when the external pilot pressure is insufficient due to simultaneous operation or restricted air piping. In this case, use the check valve (AKH series) with the external pilot port, change the piping size or adjust the set pressure to provide a constant pressure of 0.25 MPa or more.
- This product is CE / UKCA marked as a safety component as defined under the Machinery Directive 2006/42/EC / The Supply of Machinery (safety) Regulations 2008. For details please refer to the Declaration of Conformity supplied with the product.
- The valve may only be used to provide the stated safety function for the supply and removal of pressure from all or part of a pneumatic system, under the total control of a supervisory device. The valve can only perform as a safety component when properly installed in a system conforming to the appropriate safety standards.
- Any such use must be within the specified limits and application conditions for the product.
- In order to meet a required performance level as defined by the appropriate safety standard, the user must provide all the other

necessary components to complete function of the safety system.

- The user is responsible for the specification, design, implementation, validation and maintenance of the safety system.

8 Product Disposal

This product shall not be disposed of as municipal waste. Check your local regulations and guidelines to dispose this product correctly, in order to reduce the impact on human health and the environment.

9 Contacts

Refer to www.smcworld.com or www.smc.eu for your local distributor/importer.

SMC Corporation

URL : <https://www.smcworld.com> (Global) <https://www.smc.eu> (Europe)
SMC Corporation, 4-14-1, Sotokanda, Chiyoda-ku, Tokyo 101-0021, Japan
Specifications are subject to change without prior notice from the manufacturer.
© 2022 SMC Corporation All Rights Reserved.
Template DKP50047-F-085M