



ORIGINAL INSTRUCTIONS

**Instruction Manual**  
**Compact Vacuum Unit**  
**ZB Series**



The intended use of the vacuum unit is to generate vacuum and control the operation of suction and release.

**1 Safety Instructions**

These safety instructions are intended to prevent hazardous situations and/or equipment damage. These instructions indicate the level of potential hazard with the labels of "Caution," "Warning" or "Danger." They are all important notes for safety and must be followed in addition to International Standards (ISO/IEC)<sup>(1)</sup>, and other safety regulations.

- <sup>(1)</sup> ISO 4414: Pneumatic fluid power - General rules relating to systems.
- ISO 4413: Hydraulic fluid power - General rules relating to systems.
- IEC 60204-1: Safety of machinery - Electrical equipment of machines. (Part 1: General requirements)
- ISO 10218-1: Robots and robotic devices - Safety requirements for industrial robots - Part 1: Robots.

- Refer to product catalogue, Operation Manual and Handling Precautions for SMC Products for additional information.
- Keep this manual in a safe place for future reference.

<b>Caution</b>	Caution indicates a hazard with a low level of risk which, if not avoided, could result in minor or moderate injury.
<b>Warning</b>	Warning indicates a hazard with a medium level of risk which, if not avoided, could result in death or serious injury.
<b>Danger</b>	Danger indicates a hazard with a high level of risk which, if not avoided, will result in death or serious injury.

**Warning**

- Always ensure compliance with relevant safety laws and standards.
- All work must be carried out in a safe manner by a qualified person in compliance with applicable national regulations.

**2 Specifications**

**2.1 General Specifications**

Operating temperature range	-5 to 50°C (No condensation)
Fluid	Air, Inert gas
Vibration resistance <sup>Note 1)</sup>	30 m/s <sup>2</sup> (without sensor/switch with sensor) 20m/s <sup>2</sup> (with switch)
Impact resistance <sup>Note 2)</sup>	150 m/s <sup>2</sup> (without sensor/switch with sensor) 100 m/s <sup>2</sup> (with switch)

Note 1) 10 to 500 Hz for 2 hours in each direction of X, Y and Z (during de-energizing).

Note 2) 3 times in each direction of X, Y and Z (during de-energizing).

**2.2 Supply Valve/ Release Valve Common Specifications**

Valve construction	3-port direct operated poppet valve
Lubrication	Not required
Manual override <sup>Note 1)</sup>	Non-locking push type. Locking type (tool required)
Enclosure	Dustproof
Rated coil voltage	DC 24V, 12V
Allowable voltage range	Rated voltage ±10%

Note 1) Push-locking type only for the latching type.

**2 Specifications - continued**

**2.3 Supply Valve/Release Valve Specifications:**

Type	Supply Valve			Release Valve
	Large flow type (N.C)	Latching	Standard	
Valve model	ZB1-VQ110U-□	ZB1-VQ120U-□	ZB1-VQ110L-□	ZB1-VQ110-□
Applicable system	Ejector (N.C)	Pump system (N.C)	Ejector <sup>Note 1)</sup>	Ejector/Pump system (N.C)
Max. operating pressure	0.55 MPa	0.1 MPa	0.55 MPa	0.55 MPa
Min. operating pressure	0.1 MPa	-0.1 MPa	0.1 MPa	0 MPa
Response time	5 ms or less			ON: 3.5 ms OFF: 2 ms
Rated coil voltage and power consumption (Current)	24 VDC	0.7 W (29mA) <sup>Note 2)</sup>	0.7 W (29mA) <sup>Note 2)</sup>	1 W (42mA)
	12 VDC	0.7 W (58mA) <sup>Note 2)</sup>	0.7 W (58mA) <sup>Note 2)</sup>	1 W (83mA)
Electrical entry	L-type plug connector (With light/surge voltage suppressor). M-type plug connector (With light/surge voltage suppressor) <sup>Note 3)</sup>			

Note 1) Latching type is applicable only to the ejector nozzle sizes ø0.3 and ø0.4.

Note 2) Inrush: 3.1 W (10 ms after energized); Holding: 0.7 W.

Note 3) M-type can also be selected when the ejector or the pump system is selected without pressure sensor/vacuum pressure switch.

**2.4 Ejector Specifications <sup>Note 1)</sup>:**

Model	ZB03		ZB04		ZB05	ZB06
	Large flow (N.C)	Latching	Large flow (N.C)	Latching	Large flow (N.C)	Large flow (N.C)
Nozzle size (mm)	0.3		0.4		0.5	0.6
Supply pressure range (MPa) <sup>Note 2)</sup>	0.2~0.55					0.3~0.55
Standard supply pressure (MPa)	0.35	0.4	0.35	0.45	0.35	0.5
Air consumption (L/min (ANR))	3.5	4	6.5	8.5	10	18
Maximum suction flow (L/min (ANR))	2		3.5		4.5	7
Maximum vacuum pressure (kPa)	-86		-90			

Note 1) These values are representative values and may vary depending on the atmospheric pressure (weather, height above sea level, etc).

Note 2) The maximum operating pressure is 0.5 MPa when using the product either with pressure sensor or vacuum pressure switch.

**2.5 Suction Filter Specifications:**

Filtration rating	30 µm
Filtration area	130 mm <sup>2</sup>

**2 Specifications - continued**

**2.6 Pressure Sensor Specifications:**

Model	ZB1-PS1-A (PSE541)	ZB1-PS3-A (PSE543)
Rated pressure range	0 to -101 kPa	-100 to 100 kPa
Proof pressure	500 kPa	
Output voltage	1 to 5 VDC	
Output impedance	Approx. 1 kΩ	
Power supply voltage	10 to 24VDC±10%, ripple (p-p) 10% or less	
Current consumption	15mA or less	
Accuracy	±2% F.S. (Ambient temperature: based on 25°C)	
Linearity	±0.4% F.S. or less	
Repeat accuracy	±0.2% F.S. or less	
Effect of power supply voltage	±0.8% F.S. or less	
Temperature characteristics	±2% F.S. or less (Ambient temperature: based on 25°C)	
Material	Case	Resin
	Pressure sensing section	Sensor pressure receiving area: Silicone O-ring: HNBR
Lead wire	Oil resistant vinyl cabtire cable: 2.7x3,2mm(elliptic) Cross section: 0.15mm <sup>2</sup> , 3 cores, 3m, Insulator O.D: 0.9mm	

**2.7 Vacuum Pressure Switch Specifications:**

Model	ZB1-ZSE###-A (ZSE10)	ZB1-ZSF###-A (ZSE10F)
Rated pressure range	0 to -101kPa	-100 to 100 kPa
Set pressure range/ Pressure display range	10 to -105 kPa	-105 to 105 kPa
Proof pressure	500 kPa	
Maximum unit setting	0.1 kPa	
Power supply voltage	12 to 24VDC, ripple (p-p) 10% or less (with power supply polarity protection)	
Current consumption	40mA or less	
Switch output	NPN or PNP open collector 2 outputs (select)	
	Max. load current	80mA
	Max. applied voltage	28V (with NPN output)
	Residual voltage	2V or less (with load current of 80mA)
	Response time	2.5ms or less (response time selections with anti-chattering function, 20,100,500,1000,2000ms)
Short circuit protection	Yes	
Repeat accuracy	±0.2%F.S. ±1 digit	
Hysteresis	Hysteresis mode	Variable (0 or above) <sup>Note 1)</sup>
	Window comparator mode	
Display	3 ½ digit, 7 segment LED, 1-colour display (Red)	
Display accuracy	±2F.S. ±1 digit (Ambient temperature of 25±3°C)	
Indicator light	Lights up when output is turned ON. OUT1: Green, OUT2: Red	
Temperature characteristics	±2%F.S. (at 25°C in an operating temperature range of -5 to 50°C)	

**2 Specifications - continued**

**Vacuum Pressure Switch Specifications- continued:**

Model	ZB1-ZSE###-A (ZSE10)	ZB1-ZSF###-A (ZSE10F)
Environmental resistance	Enclosure	IP40
	Operating humidity range	Operating/stored: 35 to 85% RH (No condensation)
	Withstand voltage	100VAX for 1 minute between live parts and enclosure
Lead wire	Insulation resistance	500MΩ or more between live parts and enclosure (at 500VDC mega)
		Oil resistance vinyl cabtire cable. Cross section: 0.15mm <sup>2</sup> (AWG26), 5 cores, 2m. Insulator O.D: 1.0mm

Note 1) If the applied voltage fluctuates around the set value, the hysteresis must be set to a value more than the fluctuating width, otherwise chattering will occur.

**Warning**

Special products (-X) might have specifications different from those shown in this section. Contact SMC for specific drawings

**3 Installation**

**3.1 Installation**

**Warning**

- Do not install the product unless the safety instructions have been read and understood.
- If a commercially available switching power supply is used, be sure to ground the frame ground (FG) terminal.
- Do not drop, hit, or apply excessive shock to the product. Otherwise, damage to the internal parts of the product, solenoid valve, and internal parts of the pressure switch/sensor can result, causing malfunction.
- Do not pull the lead wire forcefully or lift the product by pulling the lead wire (tensile strength 35N or less). Hold the product body when handling to prevent damage, failure, or malfunction. The solenoid valve and the pressure switch/sensor will be damaged, leading to failure and malfunction
- Eliminate any dust left in the piping by using a blast of air before connecting the piping to the product. It will cause failure or malfunction.

- Do not insert metal wires or other foreign objects into the pressure port of the pressure sensor. The pressure sensor may get damaged, leading to failure and malfunction.
- If the fluid may contain foreign matter, install and connect a filter or mist separator to the inlet. It will cause failure or malfunction.

**3.2 Environment**

**Warning**

- Do not use in an environment where corrosive gases, chemicals, salt water or steam are present.
- Do not use in an explosive atmosphere.
- Do not expose to direct sunlight. Use a suitable protective cover.
- Do not install in a location subject to vibration or impact in excess of the product's specifications.
- Do not mount in a location exposed to radiant heat that would result in temperatures in excess of the product's specifications.
- Do not use in an area where surges are generated. When there are machines or equipment that generate large surge near the pressure switch/sensor (magnetic type lifter, high frequency inductive furnace, motor, etc.), this can result in deterioration and damage of the internal elements. Take measures against the surge sources and prevent the lines from coming into close contact.
- Do not use a load which generates surge voltage. When a surge-generating load such as a relay or solenoid is directly driven, use the product with a surge absorbing element built-in.
- This product is not immune to lightning strikes, so take precautions against lightning strikes.
- Excessive noises in the surrounding area may affect the functioning of the product.
- Do not let foreign matter, such as wire debris, get inside the product
- Do not use the product in an environment that is exposed to temperature cycle. Heat cycles other than ordinary changes in temperature can adversely affect the inside of the product.
- Keep within the specified operating fluid and ambient temperature range. The operating fluid and ambient temperature range is 5 to 50°C. Operation under low temperature may lead to damage or operation failure due to frozen moisture in the fluid or air. Protection against freezing is necessary. Mounting of an air dryer is recommended for

### 3 Installation - continued

elimination of drainage and water. Avoid abrupt temperature changes even within the specified temperature range.

#### 3.3 Piping

##### Caution

- Before connecting piping make sure to clean up chips, cutting oil, dust etc.
- When installing piping or fittings, ensure sealant material does not enter inside the port. When using seal tape, leave 1 thread exposed on the end of the pipe/fitting.
- Tighten fittings to the specified tightening torque.

##### Piping to the Manifold Base:

- For the PV port of the manifold base, use a tube fitting whose maximum bore size of the outside dimension is smaller than 12mm. Otherwise, the exterior of the fitting will interfere with the manifold base installation face. Recommended tube fittings: KQ2S06-01#S, KQ2S04-01#S.
- Follow the tightening instructions shown below for each thread. 1/8 (PV port): 7 to 9N Tightening torque is 3 to 5N as a guide. M5 (PV, PD port): After tightening by hand, increase the tightening by about 1/6 turn with a tightening tool. Tightening torque is 1 to 1.5N as a guide.
- When mounting or removing the tube fitting, etc. to the manifold base, hold the manifold base hold the manifold base with a spanner. If the ejector/vacuum pump system is held, it may cause air leakage or damage to the product.

##### Piping to the Vacuum (V) Port:

- Allow a sufficient margin of tube length when piping, in order to prevent twisting, tensile, moment loads, vibration or impact being applied to the tubes and fittings. This can cause damage to the tube fittings and crushing, bursting or disconnection of tubing.
- Piping to the product is assumed to be static piping. If the tube moves, it may become worn, elongated or torn due to tensile forces, or disconnected from the fitting. Ensure the tube is in a static condition at all times before using.
- Prevent the connected tube from being rotated. If the fittings are used in this way, the fitting may be broken.

- Do not lift the product by holding the piping after the tube is connected to the vacuum (V) port. Otherwise, the filter case and/or the One-touch tube fitting will be damaged.

#### 3.4 Wiring

##### Caution

- Do not pull hard on the lead wire or lift the product by holding the lead wires (tensile strength 49 N or less). Never lift the product by the lead wire of the solenoid valve or the pressure switch/sensor when fittings and piping are built in. Otherwise, damage to the solenoid valve or the internal parts of the pressure switch/sensor can result, causing malfunction or causing the connector to come off.
- Avoid repeatedly bending, stretching or applying a heavy object or force to the lead wire. Repetitive bending stress or tensile stress to the lead wire can cause the sheath of the wire to peel off. If the lead wire can move, fix it near the body of the product. The recommended bend radius of the lead wire is 6 times the outside diameter of the sheath, or 33 times the outside diameter of the insulation material, whichever is larger. Replace the damaged lead wire with a new one.
- Wire correctly. Incorrect wiring can cause malfunction or breakage of the solenoid valve or the pressure switch/sensor.
- Do not perform wiring while the power is on. Otherwise, damage to the solenoid valve or the internal parts of the pressure switch/sensor can result, causing malfunction.

The lead wire of the solenoid valve is connected as shown below. Connect each wire to the corresponding wire of the power supply.

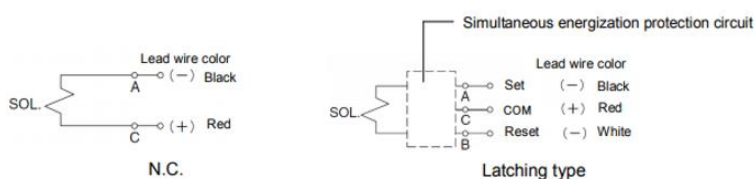

- Light surge/voltage suppressor: In the latching type, the set side (vacuum ON) and the reset side (vacuum OFF) energization are

### 3 Installation - continued

indicated by two colours - orange and green. \* The dotted lines indicate the latching and large flow type.

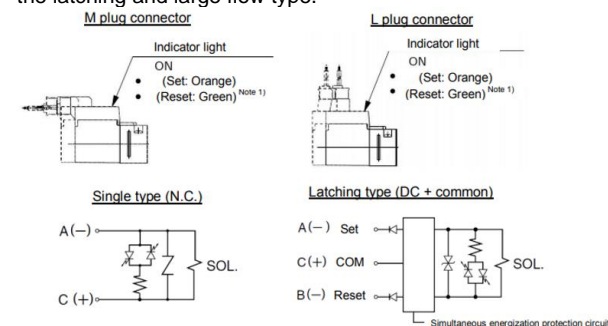

Note 1) Only the latching type has the reset function.

Note 2) NC type has polarity. ON: The orange light turns ON.

Note 3) Set side energization: orange light turns ON, reset side energization: green light turns ON, with incorrect wiring prevention (stop diode) mechanism.

Note 4) Energization on A (set) side generates vacuum and energization on B (reset) side stops generation of vacuum.

- Do not route wires and cables together with power or high voltage cables. Route the wires (piping) of the solenoid valve or the pressure switch/sensor separately from power or high voltage cables to avoid noise or surge entering the signal line from the power or high voltage line.
- Confirm proper insulation of wiring. Poor insulation (interference with other circuits, poor insulation between terminals etc.) can apply excessive voltage or current to the solenoid valve or the pressure sensor/sensor, causing damage.
- Design the system to prevent reverse current when the product is forced to operate for operational check. Depending on the circuit used, insulation may not be maintained when operation is forced, allowing reverse current to flow, which can cause malfunction and damage to the solenoid valve or the pressure switch/sensor

- Keep wiring as short as possible to prevent interference from

electromagnetic noise and surge voltage. Do not use a cable longer than 10 m. Wire the DC (-) line (solenoid valve: black, pressure switch/sensor: blue) as close as possible to the power supply.

### 4 How to Order

Refer to catalogue for 'How to Order'.

### 5 Outline Dimensions

Refer to catalogue for outline dimensions.

### 6 Maintenance

#### 6.1 General maintenance

##### Caution

- Not following proper maintenance procedures could cause the product to malfunction and lead to equipment damage.
- If handled improperly, compressed air can be dangerous.
- Maintenance of pneumatic systems should be performed only by qualified personnel.
- Before performing maintenance, turn off the power supply and be sure to cut off the supply pressure. Confirm that the air is released to atmosphere.
- After installation and maintenance, apply operating pressure and power to the equipment and perform appropriate functional and leakage tests to make sure the equipment is installed correctly.
- If any electrical connections are disturbed during maintenance, ensure they are reconnected correctly and safety checks are carried out as required to ensure continued compliance with applicable national regulations.
- Do not make any modification to the product.
- Do not disassemble the product, unless required by installation or maintenance instructions.
- Implement the maintenance checks shown in order to use the ejector and vacuum system safely and in an appropriate way for a long period of time.
- Maintenance should be performed according to the procedure indicated in the Operation Manual ZB-OM00201-A.

### 6 Maintenance - continued

- Improper handling can cause damage and malfunction of equipment and machinery.
- Maintenance work Compressed air can be dangerous when handled incorrectly. Therefore, in addition to observing the product specifications, replacement of elements and other maintenance activities should be performed by personnel with sufficient knowledge and experience pertaining to pneumatic equipment.
- Draining Remove condensate from air filters and mist separators regularly. If the collected drainage is drained to the downstream side, it can stick inside of the product, causing operation failure and failure to reach the specified vacuum pressure.
- Replace the filter element built into the ejector and the vacuum pump system and the silencer regularly. (Refer to the replacement procedure below.) It is recommended to replace the filter element and the silencer when the pressure drop reaches 5kPa as a guideline. The replacement cycle varies depending on the operating conditions, operating environment and supply air quality. However, if there is a vacuum pressure drop and/or delay in the vacuum (adsorption) response time which causes problem with the settings during operation, stop the operation of the product and replace the element regardless of the above-mentioned replacement guideline.
- Operation in an environment where there is a lot of dust in the air. The processing capacity of the filter element built into the product may be insufficient. It is recommended to use SMC's air suction filter (ZFA, ZFB, ZFC series) to avoid problems beforehand.
- Check before and after the maintenance work. When the product is to be removed, turn off the power supply, and be sure to cut off the supply pressure and exhaust the compressed air. Confirm that the air is released to atmosphere. When mounting the product after the maintenance work, supply compressed air, connect to the power, check if it functions properly and have a leakage inspection. Especially for the latching type supply valve, be sure to check that the supply valve is OFF in the initial condition because it is possible that it is ON due to vibration.
- Do not disassemble or modify the product, other than the replacement parts specified in this manual.

#### 6.2 Replacement Procedure for Filter Element:

- Hold the V port assembly with your fingers and turn it 45° in the counter clockwise direction and pull it out. For the straight type One-touch tube fitting, it can be removed by using a hexagon wrench (width across flats: 2).
- Remove the filter element from the removed filter case and mount a new filter element securely to the back of the case.
- Confirm that the filter case gasket is not displaced and that it has no foreign matter stuck to it.
- Insert the V port assembly into the ejector/vacuum pump system press it slightly and turn it for approximately 45° in the clockwise direction until it stops.

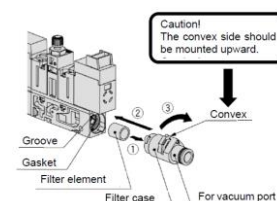

#### 6.3 Replacement Procedure for Silencer:

- Turn the body upside down. Apply a watchmaker's screw driver or your finger to the notch and slide the silencer cover in the direction indicated by the  $\Delta$  mark.
- When it clicks, the hook is disconnected. Put your Pry up and remove part A, cover.
- Remove the silencer by using a watchmaker's screw driver.
- Insert a new silencer and mount the cover by the reverse procedure of the disassembly procedure for reassembly (when replacing the silencer, the metal diffuser can be seen. This part is important to the function. Do not touch or apply force to the metal diffuser when replacing the silencer.).

### 6 Maintenance - continued

- For vacuum pump system, the silencer is not built in.

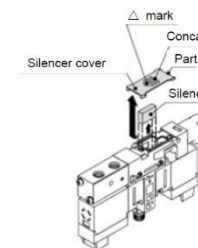

#### 6.4 Replacement Procedure for Solenoid Valve (supply valve, release valve):

- This product has a supply valve for generating vacuum and a release valve for breaking vacuum, follow the procedure to replace the solenoid valves.
- Remove the mounding screws of the solenoid valve.
- Remove the solenoid valve.
- Check there is no dust or scratches on the mounting surface. Be certain the gasket and filter element R of the supply valve are properly mounted (filter element R is installed only on the release valve).
- Tighten the mounting screw of the solenoid valve to 0.054 to 0.08 Nm.
- When replacing the solenoid valves, the valve body will come off if both the supply valve and release valve are removed at the same time. Removal of the valves should be done one at a time.

\*Function of filter element R: when the supply valve is switched OFF, atmospheric pressure flows from the vent port into the space inside the valve where there is "vacuum pressure". Filter element R is a filter mounted in the flow path. It prevents dust in the operating environment from entering the solenoid valve.

### 7 Limitations of Use

#### 7.1 Limited warranty and disclaimer/compliance requirements

Refer to Handling Precautions for SMC Products.

### 8 Product Disposal

This product shall not be disposed of as municipal waste. Check your local regulations and guidelines to dispose this product correctly, in order to reduce the impact on human health and the environment.

### 9 Contacts

Refer to [www.smcworld.com](http://www.smcworld.com) or [www.smc.eu](http://www.smc.eu) for your local distributor/importer.

## SMC Corporation

URL : <https://www.smcworld.com> (Global) <https://www.smc.eu> (Europe)  
SMC Corporation, 4-14-1, Sotokanda, Chiyoda-ku, Tokyo 101-0021, Japan  
Specifications are subject to change without prior notice from the manufacturer.  
© 2021 SMC Corporation All Rights Reserved.  
Template DKP50047-F-085M